

FCC Dynamic Frequency Selection Test Report

for

Hisense Electric Co., Ltd.

Sero 7 Pro

Model No.: M470BSA

FCC ID: W9HPADP0001

Brand: Hisense

Prepared for : Hisense Electric Co., Ltd.
No.218 Qianwangang Road, Economy &
Technology Development Zone, Qingdao,
China

Prepared By : AUDIX Technology Corporation
EMC Department
No. 53-11, Dingfu, Linkou Dist.,
New Taipei City 244, Taiwan, R.O.C.

Tel : (02) 2609-9301, 2609-2133

Fax : (02) 2609-9303

File Number : C1M1303088
(ACS Ref. No.: ACS13Q0259)
Report Number : EM-F1020237
Date of Test : Mar. 20 ~ Apr. 09, 2013
Date of Report ; Apr. 10, 2013

TABLE OF CONTENTS

Description	Page
TEST REPORT VERIFICATION.....	3
1.SUMMARY OF MEASUREMENTS AND RESULTS	4
2.GENERAL INFORMATION.....	5
2.1.Description of Device (EUT)	5
2.2.Support Equipment.....	6
2.3.Test Channel.....	6
2.4.Description of Test Facility.....	7
2.5.Measurement Uncertainty	7
3.TEST EQUIPMENT.....	8
4.WORKING MODES AND REQUIREMENT TEST ITEM.....	9
4.1.Applicability of DFS Requirements Prior To Use A Channel	9
4.2.Applicability of DFS Requirements During Normal Operation.....	9
5.DFS DETECTION THRESHOLOS AND RADAR TEST WAVEFORMS	10
5.1.Interference Threshold Value, Master or Client Incorporating In-Service Monitoring.....	10
5.2.Radar Test Waveform Minimum Step.....	10
5.3.Short Pulse Radar Test Waveforms	10
5.4.Long Pulse Radar Test Waveforms	11
5.5.Frequency Hopping Pulse Radar Test Waveforms.....	13
5.6.Conducted Calibration Setup.....	15
5.7.Radar Waveform Calibration Procedure	15
5.8.Calibration Deviation	15
5.9.Radar Waveform Calibration Result	16
6.TEST SETUP AND TEST RESULT.....	17
6.1.Test Setup	17
6.2.Channel Move Time, Channel Closing Transmission Time, Non-Occupancy Period Measurement	20
7.PHOTOGRAPHS OF MEASUREMENT.....	24

TEST REPORT VERIFICATION

Applicant : Hisense Electric Co., Ltd.
Manufacturer : Hisense Electric Co., Ltd.
FCC ID : W9HPADP0001
EUT Description : Sero 7 Pro
(A) Model No. : M470BSA
(B) Serial No. : N/A
(C) Brand : Hisense
(D) Power Supply : DC 5V
(E) Test Voltage : AC 120V, 60Hz (Via Adapter)

Measurement Standards Used:

FCC RULES AND REGULATIONS PART 15 Subpart E, Oct. 2012
(FCC CFR 47 Part 15E, §15.407)

The device described above was tested by AUDIX Technology Corporation to determine the maximum emission levels emanating from the device. The maximum emission levels were compared to the FCC Part 15 subpart E limits.

The measurement results are contained in this test report and AUDIX Technology Corporation is assumed full responsibility for the accuracy and completeness of these measurements. Also, this report shows that the EUT to be technically compliant with the requirements of FCC Part 15 standards.

This report applies to above tested sample only. This report shall not be reproduced in part without written approval of AUDIX Technology Corporation.

Date of Test: Mar. 20 ~ Apr. 09, 2013

Date of Report: Apr. 10, 2013

Producer: 
(Tina Huang/Administrator)

Signatory: 
(Ben Cheng/Manager)

1. SUMMARY OF MEASUREMENTS AND RESULTS

The EUT has been tested according to the applicable standards as referenced below.

Description of Test Item	Results
Channel Availability Check Time	N/A
Channel Move Time	PASS
Non-Occupancy Period	PASS
Channel Closing Transmission Time	PASS
U-NII Detection Bandwidth	N/A
N/A is an abbreviation for Not Applicable, sine the product is client without radar detection function	

2. GENERAL INFORMATION

2.1. Description of Device (EUT)

Product	Sero 7 Pro
Model Number	M470BSA
Serial Number	N/A
Brand Name	Hisense
Applicant	Hisense Electric Co., Ltd. No.218 Qianwangang Road, Economy & Technology Development Zone, Qingdao, China
Manufacturer	Hisense Electric Co., Ltd. No.218 Qianwangang Road, Economy & Technology Development Zone, Qingdao, China
FCC ID	W9HPADP0001
Fundamental Range	802.11b/g: 2412MHz ~ 2462MHz 802.11a: 5180MHz ~ 5240MHz (UNII Band I) and 5260MHz ~ 5320MHz (UNII Band II) 5250MHz ~ 5350MHz (DFS Function, Slave/no In service monitor, no Ad-Hoc mode) 802.11n-HT20: 2412MHz ~ 2462MHz and 5180MHz ~ 5240MHz (UNII Band I) and 5260MHz ~ 5320MHz (UNII Band II) 5250MHz ~ 5350MHz (DFS Function, Slave/no In service monitor, no Ad-Hoc mode) BT 3.0: 2402MHz ~ 2480MHz GPS: 1577.42MHz NFC: 13.56MHz
Frequency Channel	802.11b/g: 11 channels 802.11a: UNII Band I: 4channels UNII Band II: 4 channels 802.11n-HT20: 2.4GHz: 11 channels 2.4G UNI Band I: 4channels UNII Band II: 4 channels Bluetooth: 79 channels (GFSK, /4DQPSK, 8-DPSK) NFC: 1 Channel

Radio Technology	802.11b: DSSS Modulation (DBPSK/DQPSK/CCK) 802.11g: OFDM Modulation (BPSK/QPSK/16QAM/64QAM) 802.11a: OFDM Modulation (BPSK/QPSK/16QAM/64QAM) 802.11n: OFDM Modulation (SISO) (BPSK/QPSK/16QAM/64QAM) Bluetooth: FHSS (GFSK, π /4DQPSK, 8-DPSK)
Data Transfer Rate	802.11b: 1/2/5.5/11Mbps 802.11a/g: 6/9/12/18/24/36/48/54Mbps 802.11n: up to 150Mbps Bluetooth: 1/2/3Mbps
Antenna Gain	2.4GHz: 2.77dBi 5GHz: 3.19dBi
HDMI Cable	Shielded, Detachable, 1.5m, Bonded two ferrite cores
USB Cable	Shielded, Detachable, 1.2m
AC Power Adapter	Meic, M/N MN-A110-L120 I/P: 100-240V~, 50/60Hz, 0.3A Max. O/P: DC 5V, 2.0A
Date of Receipt of Sample	Mar. 18, 2013
Date of Test	Mar. 20 ~ Apr. 09, 2013

2.2. Support Equipment

Item	Manufacturer	Model	Remark
AP Server	CISCO	AIR-AP1262N-A-K9	FCC ID: LDK102073 IC:2461B-102073
AP Server	D-Link	DIR-815A1	NCC ID: CCAI10LP092AT0 FCC ID: KA2IR815A1 IC: 4216A-IR815A1

2.3. Test Channel

Frequency Band	Channel No.	Frequency
5250-5350MHz (Band 2)	60	5300MHz

2.4. Description of Test Facility

Name of Firm : **AUDIX Technology Corporation**
EMC Department
No. 53-11, Dingfu, Linkou Dist.,
New Taipei City 244, Taiwan, R.O.C.

Test Site : No. 53-11, Dingfu, Linkou Dist.,
New Taipei City 244, Taiwan, R.O.C.

NVLAP Lab. Code : 200077-0

TAF Accreditation No : 1724

2.5. Measurement Uncertainty

Test Item	Uncertainty
DFS Measurement	$\pm 0.5\text{ms}$
Threshold	$\pm 0.33\text{dB}$

3. TEST EQUIPMENT

Item	Type	Manufacturer	Model No.	Serial No.	Last Cal.	Next Cal.
1.	Vector Signal Generation	R&S	SMU200A	104893	May 07, 12'	May 06, 13'
2.	Spectrum Analyzer	R&S	FSV7	102493	Apr. 26, 12'	Apr. 25, 13'
3.	Attenuator (10dB) X2	Worken	WK0602-10	0120A02 208001S	N/A	N/A
4.	Attenuator (30 dB) X2	Worken	WK0602-30	0120A02 208002S	N/A	N/A

4. WORKING MODES AND REQUIREMENT TEST ITEM

4.1. Applicability of DFS Requirements Prior To Use A Channel

Requirement	Operational Mode		
	Master	Client without radar detection	Client with radar detection
Non-Occupancy Period	✓	Not required	✓
DFS Detection Threshold	✓	Not required	✓
Channel Availability Check Time	✓	Not required	Not required
Uniform Spreading	✓	Not required	Not required
U-NII Detection Bandwidth	✓	Not required	✓

4.2. Applicability of DFS Requirements During Normal Operation

Requirement	Operational Mode		
	Master	Client without radar detection	Client with radar detection
DFS Detection Threshold	✓	Not required	✓
Channel Closing Transmission Time	✓	✓	✓
Channel Move Time	✓	✓	✓
U-NII Detection Bandwidth	✓	Not required	✓

5. DFS DETECTION THRESHOLOLOS AND RADAR TEST

WAVEFORMS

5.1. Interference Threshold Value, Master or Client Incorporating In-Service Monitoring

Maximum Transmit Power	Value (See Notes 1 and 2)
≥ 200 milliwatt	-64dBm
< 200 milliwatt	-62dBm

Note 1: This is the level at the input of the receiver assuming a 0 dBi receive antenna.

Note 2: Throughout these test procedures an additional 1 dB has been added to the amplitude of the test transmission waveforms to account for variations in measurement equipment. This will ensure that the test signal is at or above the detection threshold level to trigger a DFS response.

The radar Detection Threshold, lowest antenna gain is the parameter of interference radar DFS detection threshold.

5.2. Radar Test Waveform Minimum Step

Step intervals of 0.1 microsecond for Pulse Width, 1 microsecond for PRI, 1MHz for chirp width and 1 for the number of pulses will be utilized for the random determination of specific test waveforms.

5.3. Short Pulse Radar Test Waveforms

Radar Type	Pulse Width (μsec)	PRI (μsec)	Number of Pulse	Minimum Percentage of Successful Detection	Minimum number of Trials
1	1	1428	18	60%	30
2	1-5	150-230	23-29	60%	30
3	6-10	200-500	16-18	60%	30
4	11-20	200-500	12-16	60%	30
Aggregate (Radar Types 1-4)				80%	120

A minimum of 30 unique waveforms are required for each of the short pulse radar type 2 through 4. For short pulse radar type 1, the same waveform is used a minimum of 30 times. If more than 30 waveforms are used for short pulse radar types 2 through 4, then each additional waveform must also be unique and not repeated from the previous waveforms. The aggregate is the average of the percentage of successful detections of short pulse radar types 1-4.

FCC Radar Types (1~4) System Diagram

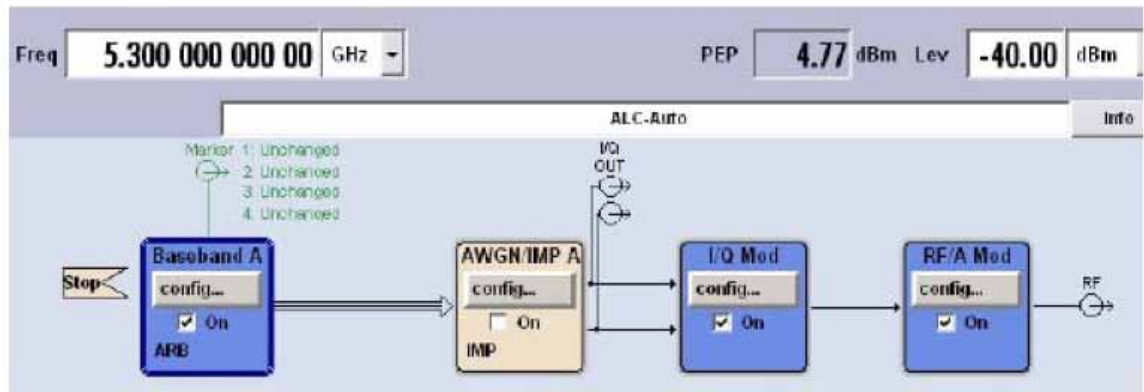

Used R&S SMU200A (Vector SG with two ARB)

B11: Base-band Generator with ARB (16M samples) and Digital Modulation

B13: Base-band Main Module

B106: frequency range (100 kHz to 6 GHz)

For selecting the waveform parameters from within the bounds of the signal type, system was random selection using uniform distribution.

5.4. Long Pulse Radar Test Waveforms

Radar Type	Pulse Width (μsec)	Chirp Width (MHz)	PRI (μsec)	Number of Pulse Per Burst	Number of Bursts	Minimum Percentage of Successful Detection	Minimum of Trials
5	50-100	5-20	1000-2000	1-3	8-20	80%	30

The parameters for this waveform are randomly chosen. Thirty unique waveforms are required for the Long Pulse radar test signal. If more 30 waveforms are used for the Long Pulse radar test signal, then each additional waveform must also be unique and not repeated from the previous waveforms. Each waveform is defined as following:

- (1) The transmission period for the Long Pulse Radar test signal is 12 seconds.
- (2) There are a total of 8 to 20 Bursts in the 12 second period, with the number of Bursts being randomly chosen. This number is Burst_Count.
- (3) Each Burst consists of 1 to 3 pulses, with the number of pulses being randomly chosen. Each Burst within the 12 second sequence may have a different number of pulses.
- (4) The pulse width is between 50 and 100 microseconds, with the pulse width being randomly chosen. Each pulse within a Burst will have the some pulse width. Pulses in different Bursts may have different pulse widths.
- (5) Each pulse has a linear FM chirp between 5 and 20MHz, with the chirp width being randomly chosen. Each pulse within a Burst will have the same chirp width. Pulses in different Burst may have different chirp widths. The chirp is centered on the pulse. For example, with a radar frequency of 5300MHz and a 20MHz chirped signal, the chirp starts at 5290MHz and ends at 5310MHz.

- (6) If more than one pulse is present in a Burst, the time between the pulses will be between 1000 and 2000 microseconds, with the time being randomly chosen. If three pulses are present in a Burst, the time between the first and second pulses is chosen independently of the time between the second and third pulses.
- (7) The 12 second transmission period is divided into even intervals. The number of intervals is equal to Burst_Count. Each interval is of length $(12000000/\text{Burst_Count})$ microseconds. Each interval contains one Burst. The start time for the Burst, relative to the beginning of the interval, is between 1 and $[(12000000/\text{Burst_Count}) - (\text{Total Burst length}) + (\text{One Random PRI interval})]$ microseconds, with the start time being randomly chosen. The step interval for the start time is 1 microsecond. The start time for each Burst is chosen independently.

A representative example of a Long Pulse radar test waveform:

- (1) The total test signal length is 12 seconds.
- (2) 8 Bursts are randomly generated for the Burst_Count.
- (3) Burst 1 has 2 randomly generated pulses.
- (4) The pulse width (for both pulses) is randomly selected to be 75 microseconds.
- (5) The PRI is randomly selected to be at 1213 microseconds.
- (6) Bursts 2 through 8 are generated using steps 3-5.
- (7) Each Burst is contained in even intervals of 1500000 microseconds. The starting location for Pulse 1. Burst 1 is randomly generated (1 to 1500000 minus the total Burst 1 length + 1 random PRI interval) at the 325001 microsecond step. Bursts 2 through 8 randomly fall in successive 1500000 microsecond intervals (i.e. Burst 2 falls in the 1500001-3000000 microsecond range).

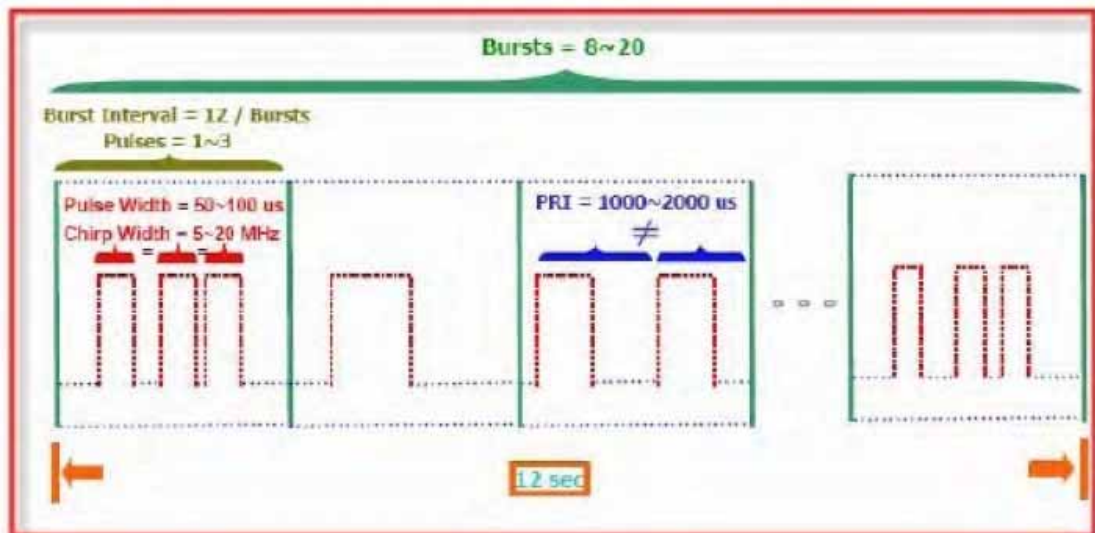

FCC Radar Types (5) System Diagram

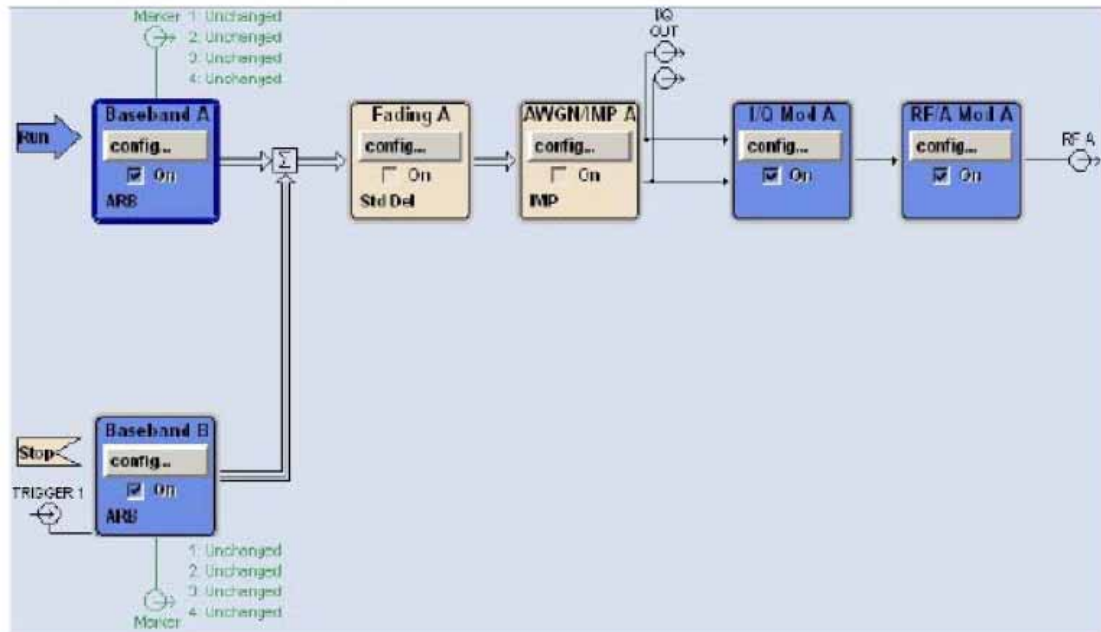

Used R&S SMU200A (Vector SG with two ARB)

Path A/Path B Two B11: Base-band Generator with ARB (16M samples) and Digital Modulation

B13: Base-band Main Module

B106: frequency range (100 kHz to 6 GHz)

For selecting the waveform parameters from within the bounds of the signal type, system was random selection using uniform distribution.

5.5. Frequency Hopping Pulse Radar Test Waveforms

Radar Type	Pulse Width (μsec)	PRI (μsec)	Pulses Per Hop	Hopping Rate (kHz)	Hopping Sequence Length (ms)	Minimum Percentage of Successful Detection	Minimum of Trials
6	1	333	9	0.333	300	70%	30

For the Frequency Hopping Radar Type, the same Burst parameters are used for each waveform. The hopping sequence is different for each waveform and a 100-length segment is selected from the hopping sequence defined by the following algorithm:

The first frequency in a hopping sequence is selected randomly from the group of 475 integer frequencies from 5250-5274MHz. Next, the frequency that was just chosen is removed from the group and a frequency is randomly selected from the remaining 474 frequencies in the group. This process continues until all 475 frequencies are chosen for the set. For selection of random frequency, the frequencies remaining within the group are always treated as equally likely.

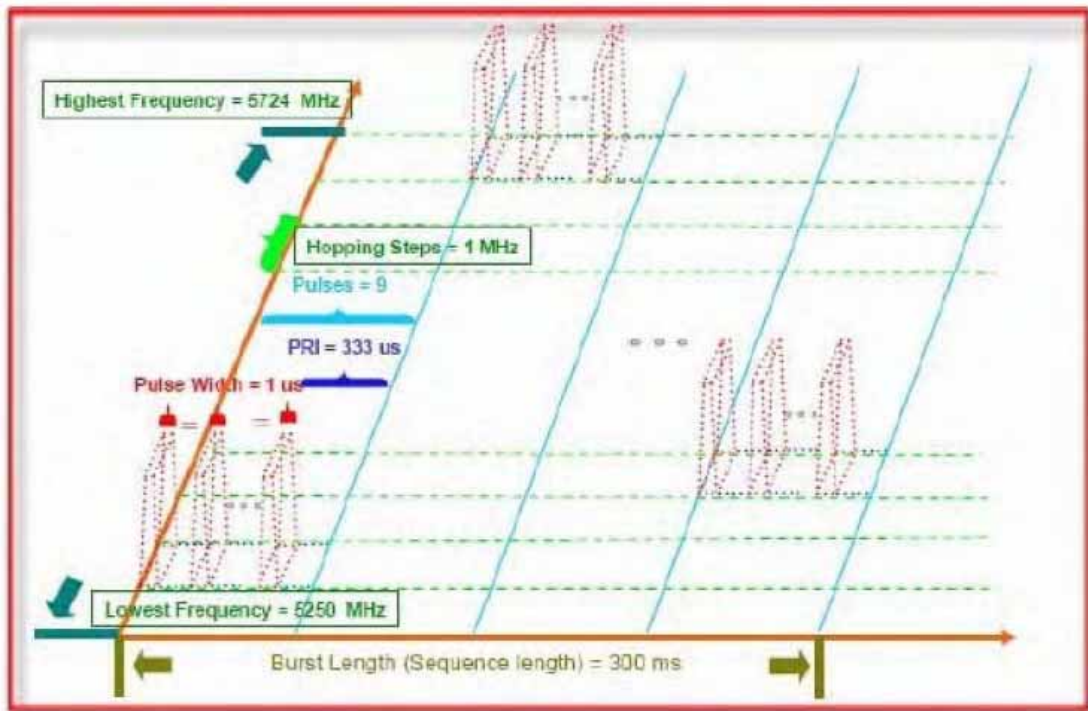

FCC Radar Types (6) System Diagram

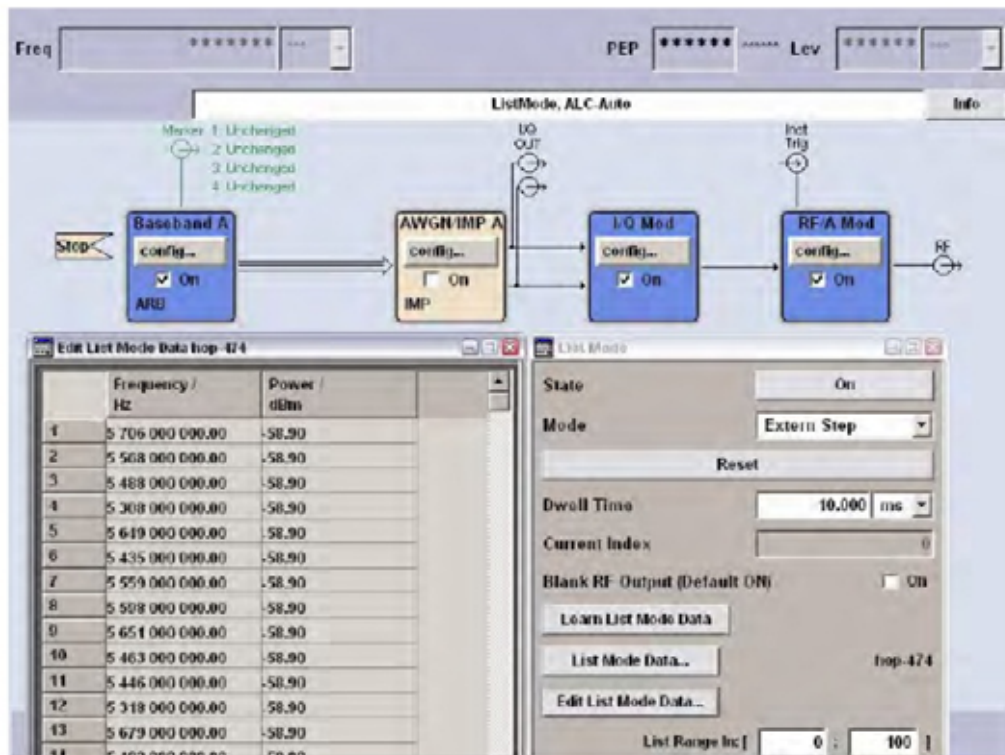

Used R&S SMU200A (Vector SG with two ARB)

B11: Base-band Generator with ARB (16M samples) and Digital Modulation

B13: Base-band Main Module

B106: frequency range (100 kHz to 6 GHz)

For selecting the waveform parameters from within the bounds of the signal type, system was random selection using uniform distribution.

5.6. Conducted Calibration Setup

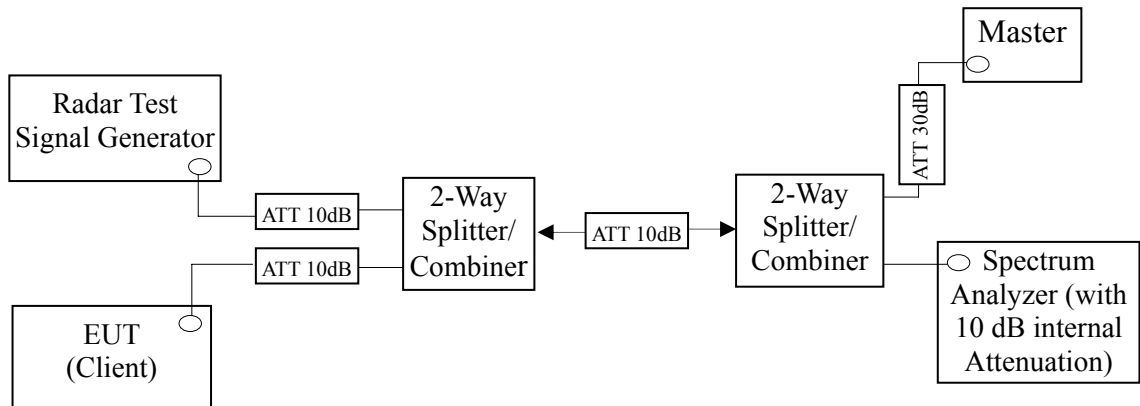

5.7. Radar Waveform Calibration Procedure

The measured frequency is 5300MHz. The radar signal was the same as transmitted channels, and injected into the antenna port of AP (master) or Client Device with Radar Detection, measured the channel closing transmission time and channel move time. The calibrated conducted detection threshold level is set to -59dBm. The tested level is lower than required level hence it provides margin to the limit.

5.8. Calibration Deviation

There is no deviation with the original standard.

5.9. Radar Waveform Calibration Result

DFS detection threshold level and the burst of pulses on the Channel frequency

5300MHz

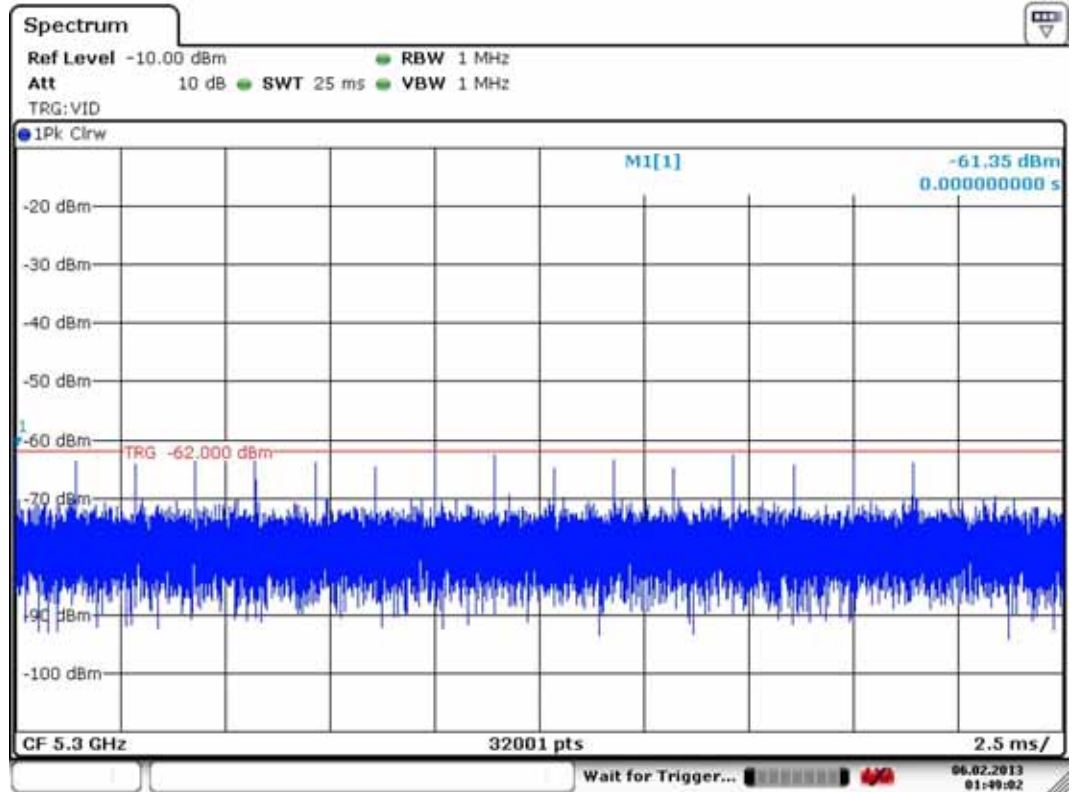

Date: 20.MAR.2013

6. TEST SETUP AND TEST RESULT

6.1. Test Setup

6.1.1. Test Setup Diagram

Following is the test setup for generated the radar waveforms and used to monitor UNII device.

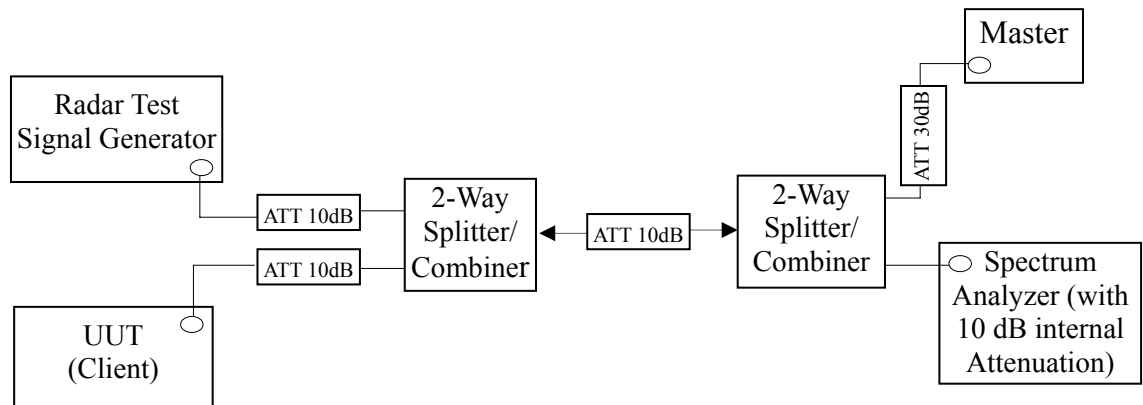

6.1.2. Test Setup Operation

System testing was performed with the designated MPEG test file that streams full motion video from the Access Point to Client in full motion video mode using the media player with the V2.61 Codec package. This file is used by IP and Frame based systems for loading the test channel during the in-service compliance testing of the U-NII device. The waveform parameters from within the bounds of the signal type are selected randomly using uniform distribution.

A spectrum analyzer is used as a monitor to verify that the EUT has vacated the Channel within the (Channel Closing Transmission Time and Channel Move Time, and does not transmit on a Channel during the Non-Occupancy Period after the detection and Channel move. It is also used to monitor EUT transmissions during the Channel Availability Check Time.

6.1.3. Test Setup for Data Traffic Plot
 Master Plot (5300MHz)

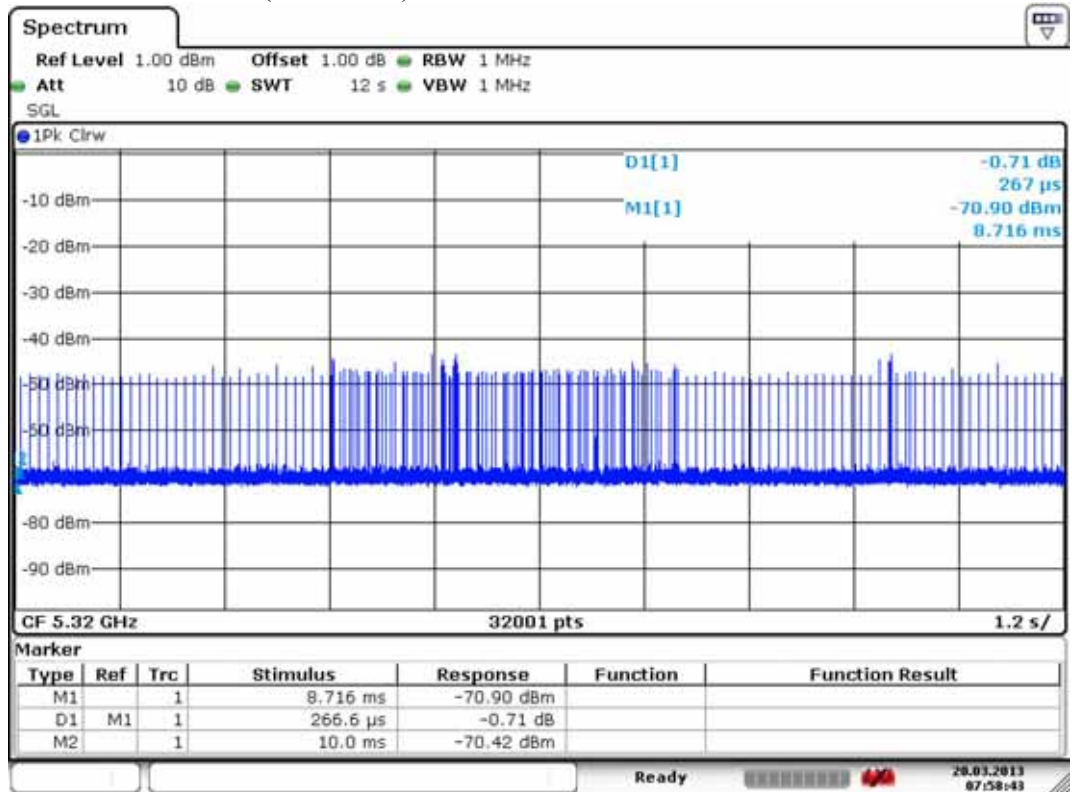

Date: 20.MAR.2013 07:58:43

EUT (Slave) Plot (5300MHz)

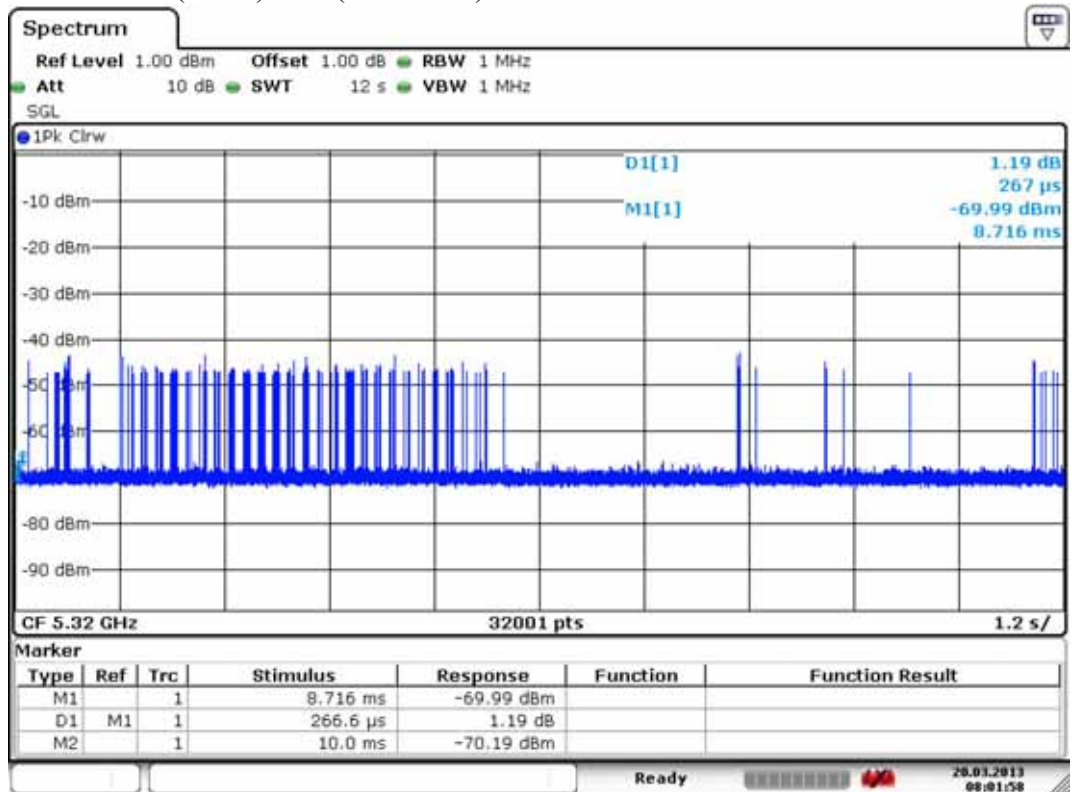

Date: 20.MAR.2013 08:01:58

Traffic (5300MHz)

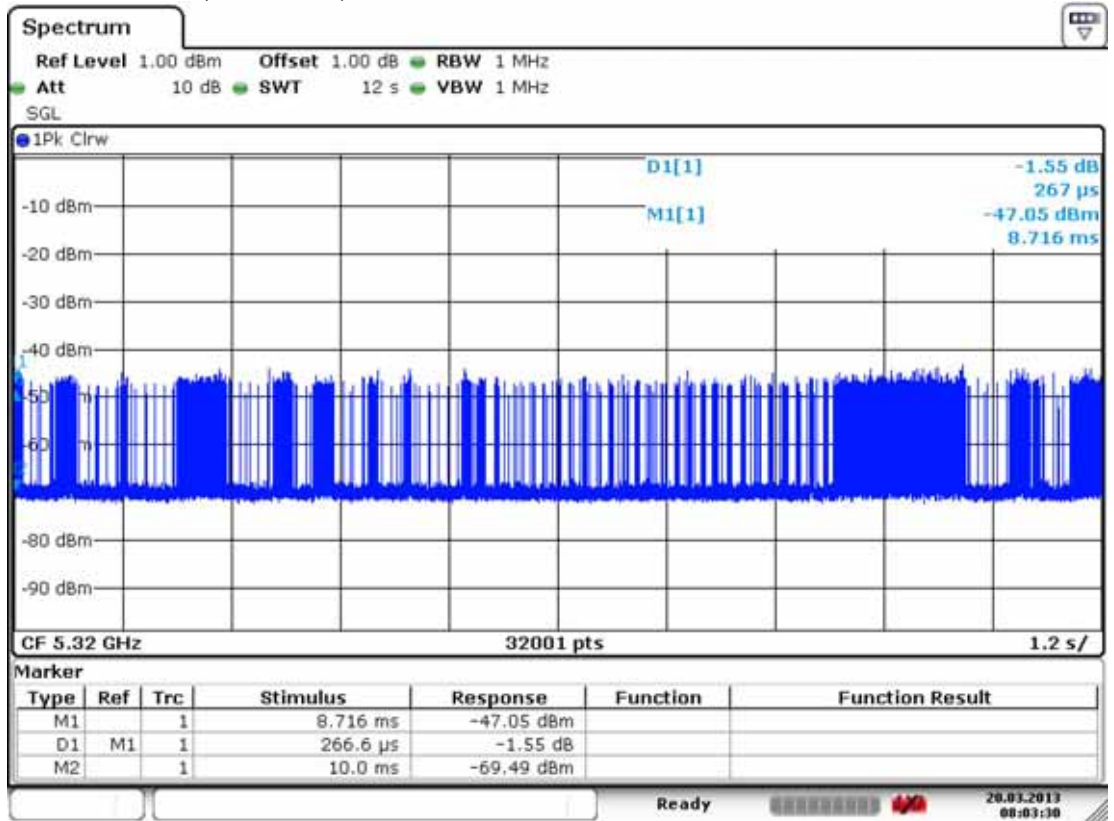

Date: 20.MAR.2013 08:03:30

6.2. Channel Move Time, Channel Closing Transmission Time, Non-Occupancy Period Measurement

6.2.1. Limit

Parameter	Value
Channel Move Time	10 seconds See Note 1.
Channel Closing Transmission Time	200 milliseconds + an aggregate of 60 milliseconds over remaining 10 second period. See Notes 1 and 2.
Non-Occupancy Period	Minimum 30 minutes
<p>Note 1: The instant that the Channel Move Time and the Channel Closing Transmission Time begins is as follows:</p> <ol style="list-style-type: none"> For the Short Pulse Radar Test Signals this instant is the end of the Burst. For the Frequency Hopping radar Test Signal, this instant is the end of the last radar Burst generated. For the Long Pulse Radar Test Signal this instant is the end of the 12 second period defining the Radar Waveform. <p>Note 2: The Channel Closing Transmission Time is comprised of 200 milliseconds starting at the beginning of the Channel Move Time plus any additional intermittent control signals required to facilitate a Channel move (an aggregate of 60 milliseconds) during the remainder of the 10 second period. The aggregate duration of control signals will not count quiet periods in between transmissions.</p>	

6.2.2. Test Procedures

- 6.2.2.1. When a radar Burst with a level equal to the DFS Detection Threshold + 1dB is generated on the operating channel of the U-NII device. A U-NII device operating as a Client Device will associate with the Master of channel. Stream the MPEG test file from the Master Device to the Client Device on the selected channel for entire period of the test. At time to the radar waveform generator sends a Burst of pulses for each of the radar types at Detection Threshold + 1dB.
- 6.2.2.2. Observe the transmissions of the EUT at the end of the radar Burst on the Operating channel. Measure and record the transmissions from the EUT during the observation time [Channel Move Time]. One 10 Second plot be reported for the short Pulse Radar type 1-4 and one for the Long Pulse Radar Type test in a 22 second plot. The plot for the Short Pulse Radar types start at the end of the radar burst. The Channel Move Time will be calculated based on the plot of the short Pulse Radar Type. The Long Pulse Radar Type plot show the device ceased transmissions within the 10 second window after detection has occurred. The plot for the Long Pulse Radar type should start at the beginning of the 12 second waveform.
- 6.2.2.3. Measure the EUT for more than 30 minutes following the channel close/move time to verify that the EUT does not resume only transmissions on this channel.

6.2.3. Test Result

Applicability of DFS Requirement During Normal Operation

6.2.3.1. Channel Closing Transmission Time & Channel Move Time (PASS)

Test Date: Apr. 09, 2013

Temperature: 20

Humidity:56%

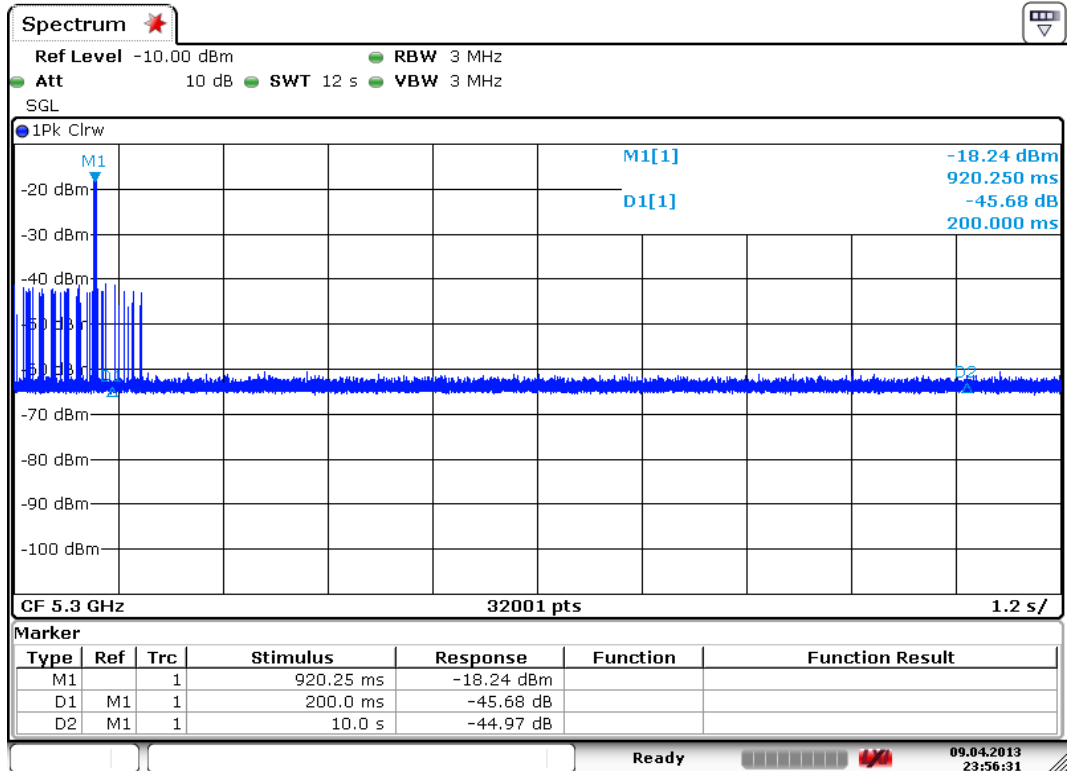

Date: 9.APR.2013 23:56:31

Channel move time > 10 S

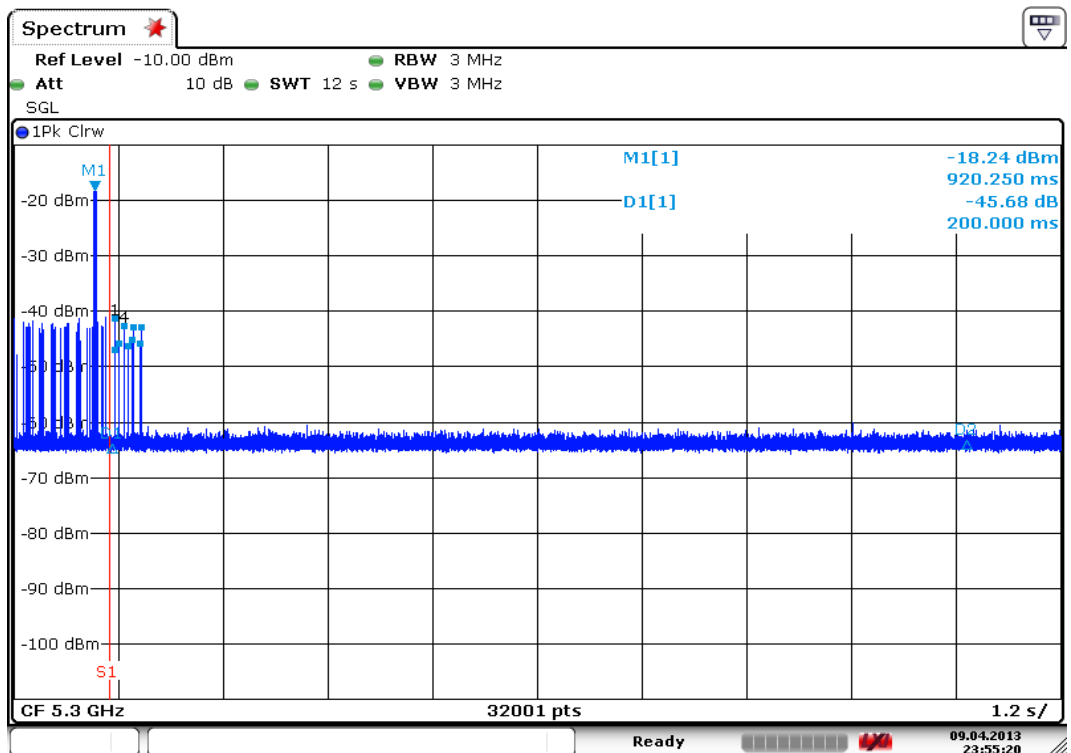

Date: 9.APR.2013 23:55:21

Test Channel: CH 60, Test Frequency: 5300MHz

Channel Closing Transmission Time Calculated	
Sweep Time(S) sec	12
Sweep points (P)	32001
Number of Sweep points in 10 sec (N)	9
Channel Closing Time (C)	3.374 ms

Channel closing time is calculated from $C=N \cdot dwell$; where dwell is the occupancy time per sweep point calculated by the formula: $dwell=S/P$. N is the number of sweep points indicating transmission after S1; where S1 is the time 200ms after radar signal is detected.

6.2.3.2. Non-Occupancy Period (PASS)

Test Date : Apr. 08, 2013 Temperature : 22 Humidity : 54%

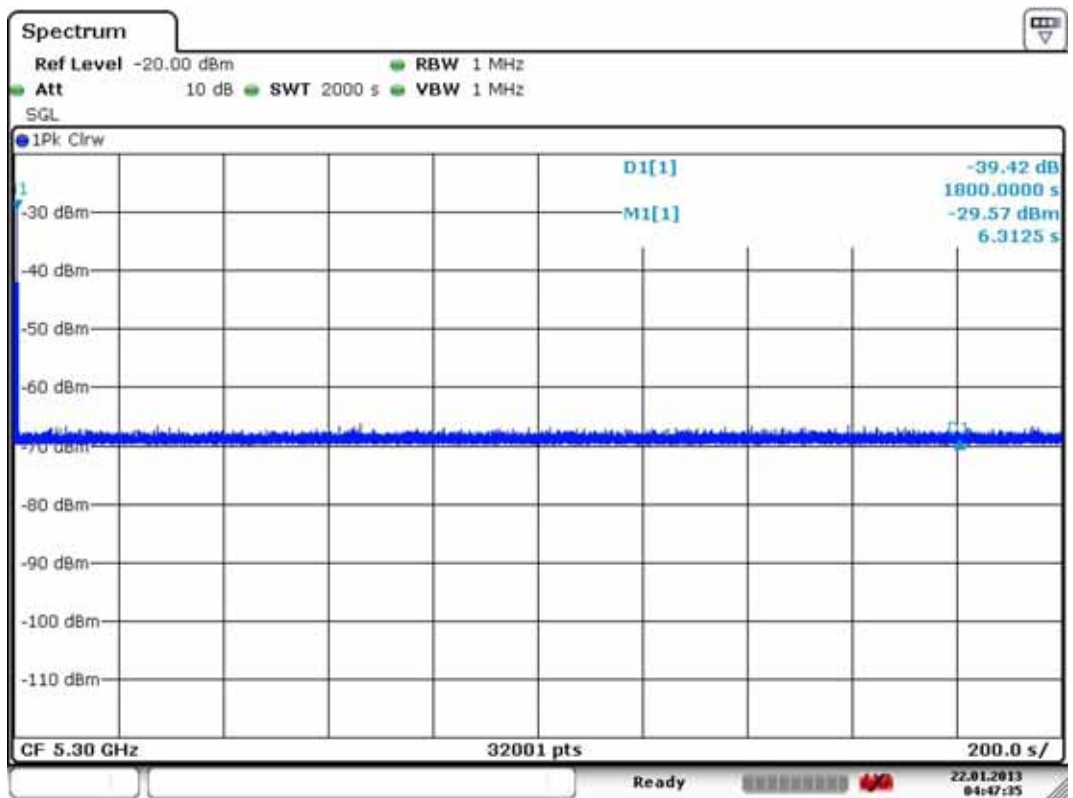

Test Channel	Test Frequency	Measured Value	Limit
60	5300MHz	>1800s	Minimum 30 minutes