

Application for FCC Certificate
On Behalf of
Hisense Electric Co., Ltd.

LED LCD TV

Model No.	Brand
LTDN50K220WUS	Hisense
50H5B	
50H5B0	

FCC ID : W9HLCDF0058

Prepared For : Hisense Electric Co., Ltd.
No.218 Qianwangang Road, Economy & Technology
Development Zone, Qingdao, China

Prepared By : Audix Technology (Shanghai) Co., Ltd.
3F and 4F, 34Bldg 680 Guiping Rd,
Caohejing Hi-Tech Park,
Shanghai 200233, China

Tel: +86-21-64955500
Fax: +86-21-64955491

Report No. : ACI-F15093
Date of Test : May 12 - 23, 2015
Date of Report : May 27, 2015

TABLE OF CONTENTS

	Page
1 SUMMARY OF STANDARDS AND RESULTS	4
1.1 Description of Standards and Results.....	4
2 GENERAL INFORMATION	5
2.1 Description of Equipment Under Test.....	5
2.2 Peripherals.....	6
2.3 Description of Test Facility.....	6
2.4 Measurement Uncertainty.....	8
3 CONDUCTED EMISSION TEST	9
3.1 Test Equipment.....	9
3.2 Block Diagram of Test Setup.....	9
3.3 Conducted Emission Limit [FCC Part 15 Subpart B 15.107(a)].....	10
3.4 Test Configuration.....	10
3.5 Operating Condition of EUT.....	11
3.6 Test Procedures.....	11
3.7 Test Results.....	12
4 RADIATED EMISSION TEST	18
4.1 Test Equipment.....	18
4.2 Block Diagram of Test Setup.....	18
4.3 Radiated Emission Limit [FCC Part 15 Subpart B 15.109(a)].....	19
4.4 Test Configuration.....	19
4.5 Operating Condition of EUT.....	20
4.6 Test Procedures.....	20
4.7 Test Results.....	21
5 DEBUG DESCRIPTION	28
6 DEVIATION TO TEST SPECIFICATIONS	29

TEST REPORT FOR FCC CERTIFICATE

Applicant : Hisense Electric Co., Ltd.
 Manufacturer : Hisense Electric Co., Ltd.
 Factory #1 : Hisense Electric Co., Ltd.
 Factory #2 : Tatung Mexico S.A. de C.V.
 EUT Description : LED LCD TV

Model No.	Brand	Power Supply
Refer to Sec2.1	Hisense	120V/60Hz

Test Procedure Used:

*FCC RULES AND REGULATIONS PART 15 SUBPART B CLASS B OCTOBER 2014
AND ANSI C63.4-2003*

The device described above is tested by Audix Technology (Shanghai) Co., Ltd. to determine the maximum emission levels emanating from the device. The maximum emission levels are compared to the FCC Part 15 Subpart B (Class B) limits both radiated and conducted emissions.

The test results are contained in this test report and Audix Technology (Shanghai) Co., Ltd. is assumed full responsibility for the accuracy and completeness of these measurements. This report shows that the EUT (M/N: Refer to Sec2.1) which was tested in 3m anechoic chamber May 12 - 23, 2015 is technically compliance with the FCC official limits also.

This report applies to above tested sample only. This report shall not be reproduced in part without written approval of Audix Technology (Shanghai) Co., Ltd.

This report contains data that are not covered by the NVLAP accreditation.

This report must not be used by the client to claim product certification, approval, or endorsement by NVLAP, NIST, or any agency of the federal government.

The test results for EUT's TV functions are contained in No.F15092, a Verification report.

Date of Test : May 12 - 23, 2015 Date of Report : May 27, 2015

Producer : Alan He
ALAN HE / Assistant

Review : Sammy Chen
SAMMY CHEN / Manager

 For and on behalf of
Audix Technology (Shanghai) Co., Ltd.

Signatory : Byron Kwo
Authorized Signature EMC BYRON KWO / Assistant General Manager

1 SUMMARY OF STANDARDS AND RESULTS

1.1 Description of Standards and Results

The EUT have been tested according to the applicable standards as referenced below:

Description of Test Item	Standard	Limits	Results
EMISSION			
Conducted Disturbance at the Mains Terminal	FCC RULES AND REGULATIONS PART 15 SUBPART B OCTOBER 2014 AND ANSI C63.4-2003	15.107(a) Class B	Pass
Radiated Disturbance	FCC RULES AND REGULATIONS PART 15 SUBPART B OCTOBER 2014 AND ANSI C63.4-2003	15.109(a) Class B	Pass

2 GENERAL INFORMATION

2.1 Description of Equipment Under Test

Description	:	LED LCD TV
Type of EUT	:	<input checked="" type="checkbox"/> Production <input type="checkbox"/> Pre-product <input type="checkbox"/> Pro-type
Model No.	:	LTDN50K220WUS, 50H5B, 50H5B0
Note	:	The above models are all the same except for model name. LTDN50K220WUS model is tested and recorded in the report.
Brand Name	:	Hisense
Applicant	:	Hisense Electric Co., Ltd. No.218 Qianwangang Road, Economy & Technology Development Zone, Qingdao, China
Manufacturer	:	Hisense Electric Co., Ltd. No.218 Qianwangang Road, Economy & Technology Development Zone, Qingdao, China
Factory #1	:	Hisense Electric Co., Ltd. No.218 Qianwangang Road, Economy & Technology Development Zone, Qingdao, China
Factory #2	:	Tatung Mexico S.A. de C.V. Miguel Catalán 420, Parque Industrial Rio Bravo, Cd. Juarez, Chih., CP 32557
LCD Panel	:	Manufacturer : Hisense M/N : HD500DF-B54(020)\S8\GM\ROH
Tuner	:	Manufacturer : XuGuang Tech. Co., Ltd. M/N : SDVT-10A/WF2
Max Resolution	:	1920*1080@60Hz
HDMI Cable*3 (Lab provide)	:	Shielded, Detachable, 1.00m, with two cores
Power Cord	:	Unshielded, Detachable, 1.80m, without core
LAN Cable (Lab provide)	:	Unshielded, Detachable, 1.50m, without core

Remark:

The EUT is a LED LCD TV which input/output ports as follows:

Side Port:

- (1) One USB1 Port : Connected with U-Disk #1
- (2) One USB2 Port : Connected with U-Disk #2
- (3) One ANT/CABLE IN Port : Connected with Antenna or ATSC SG / TV SG
- (4) One component of YPbPr+Audio Port : Connected with DVD PLAYER #1
- (5) One Audio out Port : Connected with Earphone

Back Port:

- (1) One HDMI3/ARC Port : Connected with DVD PLAYER #2
- (2) One HDMI2 Port : Connected with DVD PLAYER #1
- (3) One DVI Audio in Port : Connected with PC
- (4) One LAN Port : Connected with PC
- (5) One Digital Audio Out Port : Connected with DVD PLAYER #2
- (6) One HDMI1/ DVI Port : Connected with PC

2.2 Peripherals

2.2.1 PC

Manufacturer : HP
 Model Number : dx7200MT
 Serial Number : CNG622017W
 Power Cord : Unshielded, Detachable, 1.8m
 Certificate : FCC DoC; CE/EMC; VCCI; C-Tick; BSMI, 3C, MIC

2.2.2 Printer

Manufacturer : HP
 Model Number : P1007
 Serial Number : VNFN713831
 Data Cable : Shielded, detachable, 1.8m
 Certificate : GS, CE/EMC, C-Tick, FCC DoC

2.2.3 Keyboard

Manufacturer : HP
Model Number : CS105
Serial Number : 9GTRNB1300120632
Data Cable : Shielded, undetachable, 1.8m
Certificate : CE/EMC, FCC DoC, VCCI, MIC,
C-Tick, BSMI

2.2.4 Mouse

Manufacturer : HP
Model Number : CS105
Serial Number : 9GTRNB1300120632
Data Cable : Shielded, Undetachable, 1.8m.
Certificate : CE/EMC, FCC DoC, VCCI, MIC,
C-Tick, BSMI

2.2.5 Modem

Manufacturer : TP-LINK
Model Number : TM-EC5658V
Serial Number : 07123301053
Data Cable : Shielded, Detachable, 1.8m
Certificate : FCC DoC, CE/EMC, CCC

2.2.6 Earphone

Manufacturer : audio-technica
Model Number : ATH-CKL200

2.2.7 TV Signal Generator

Manufacturer : FLUKE
Model Number : 54200m01
Serial Number : 814008
Data Cable : Shielded, detachable, 2.0m
Power Cord : Unshielded, detachable, 2.0m
Certificate : CE/EMC, FCC DoC, CCC

2.2.8 ATSC Signal Generator

Manufacturer : SENCORE
Model Number : ATSC997
Serial Number : 6790071

2.2.9 DVD PLAYER #1

Manufacturer : PHILIPS
Model Number : DVP3986K/93
Serial Number : KX1A0902120108
Certificate : FCC DoC, CE/EMC, CCC

2.2.10 DVD PLAYER #2

Manufacturer : PHILIPS
Model Number : DVP3986K/93
Serial Number : KX1A0902120082
Certificate : FCC DoC, CE/EMC, CCC

2.2.11 U-Disk #1

Manufacturer : Kingmax
Model Number : 8G
Certificate : CE/EMC, FCC DoC, IC

2.2.12 U-Disk #2

Manufacturer : Kingmax
Model Number : 8G
Certificate : CE/EMC, FCC DoC, IC

2.3 Description of Test Facility

Site Description (No.3 3m Chamber) : Sept. 17, 1998 file on
Jan.15, 2015 Renewed
Federal Communications Commission
FCC Engineering Laboratory
7435 Oakland Mills Road
Columbia, MD 21046, USA

Name of Firm : Audix Technology (Shanghai) Co., Ltd.

Site Location : 3F 34Bldg 680 Guiping Rd,
Caohejing Hi-Tech Park,
Shanghai 200233, China

NVLAP Lab Code : 200371-0

2.4 Measurement Uncertainty

Conducted Emission Expanded Uncertainty : U = 2.8dB

Radiated Emission Expanded Uncertainty (30-200MHz):
U = 4.4dB (Horizontal)
U = 4.4dB (Vertical)

Radiated Emission Expanded Uncertainty (200M-1GHz):
U = 4.4dB (Horizontal)
U = 5.5dB (Vertical)

Radiated Emission Expanded Uncertainty (1GHz-6GHz):
U = 5.1dB

3 CONDUCTED EMISSION TEST

3.1 Test Equipment

The following test equipments are used during the conducted emission test in a shielded room:

Item	Type	Manufacturer	Model No.	Serial No.	Last Cal.	Next Cal.
1.	Test Receiver	R&S	ESCI	101303	Jul 01, 2014	Jun 30, 2015
2.	Artificial Mains Network (AMN)	R&S	ENV4200	100125	Jun 27, 2014	Jun 26, 2015
3.	Line Impedance Stabilization Network (LISN)	Kyoritsu	KNW-407	8-1280-4	Mar 20, 2015	Mar 19, 2016
4.	50Ω Coaxial Switch	Anritsu	MP59B	6200426389	Mar 18, 2015	Sep 17, 2015
5.	50Ω Terminator	Anritsu	BNC	001	Mar 20, 2015	Mar 19, 2016
6.	Software	Audix	E3	6.111206	--	--

3.2 Block Diagram of Test Setup

3.2.1 EUT & Peripherals

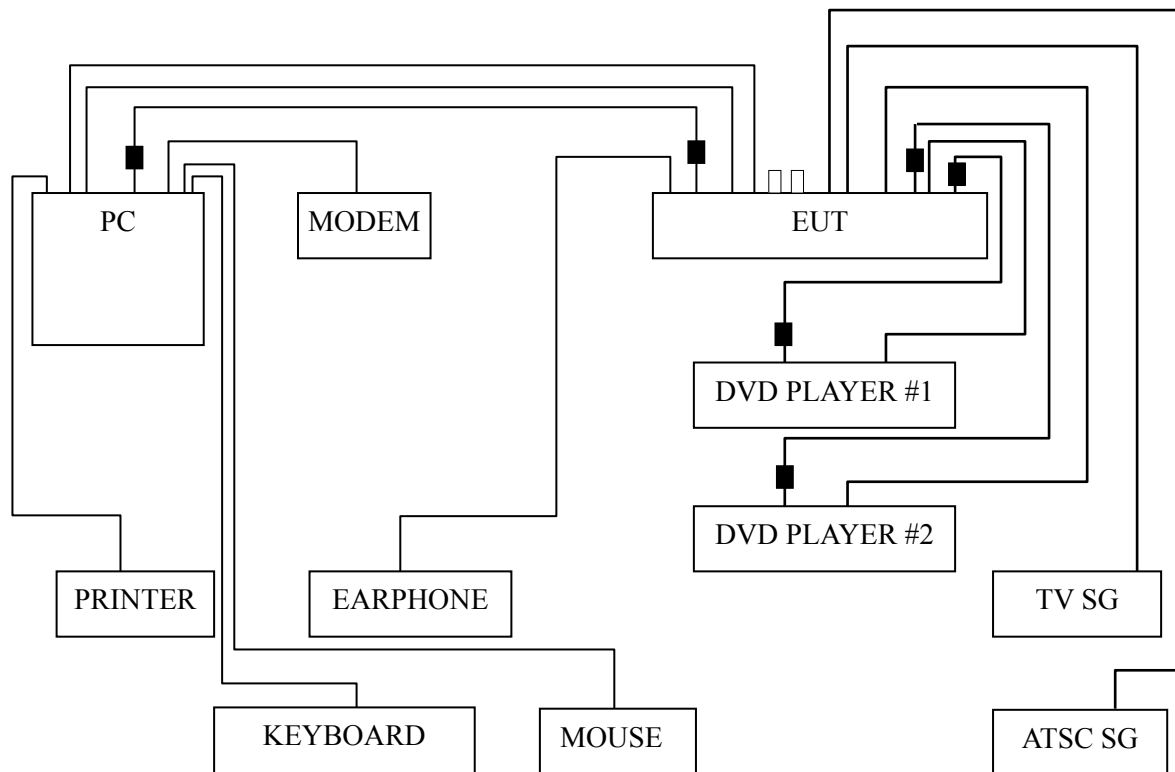

□ : U-Disk

■ : Ferrite Core

3.2.2 Conducted Disturbance Test Setup

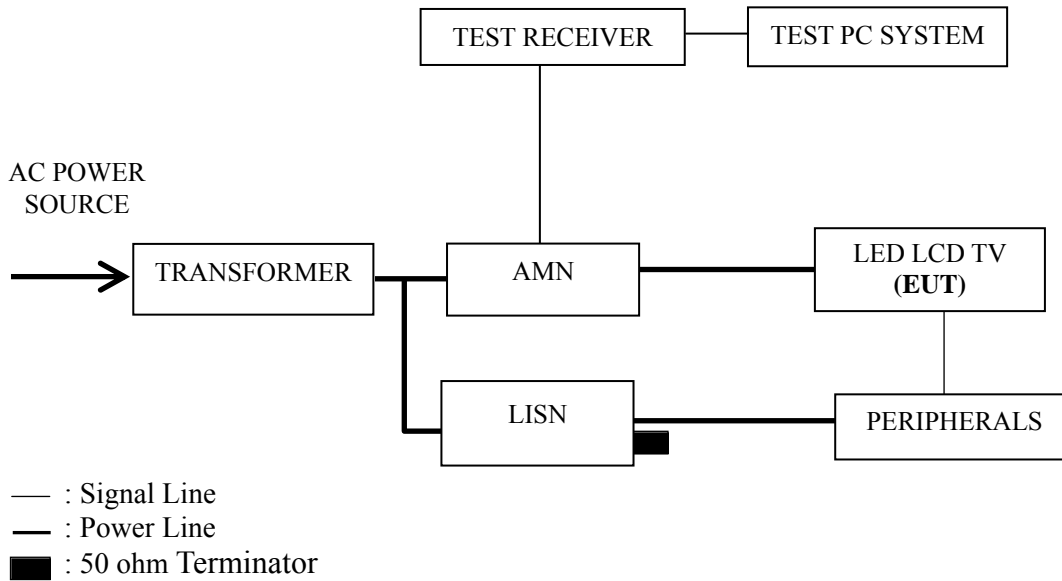

3.3 Conducted Emission Limit [FCC Part 15 Subpart B 15.107(a)]

Frequency Range (MHz)	Limits dB (μ V)	
	Quasi-peak	Average
0.15 ~ 0.5	66~56	56~46
0.5 ~ 5	56	46
5 ~ 30	60	50

NOTE 1 – The lower limit shall apply at the transition frequencies.
 NOTE 2 – The limit decreases linearly with the logarithm of the frequency in the range 0.15 MHz~0.50 MHz

3.4 Test Configuration

The EUT (listed in Sec.2.1) and the peripherals (listed in Sec 2.2) were installed as shown on Sec.3.2 to meet FCC requirement and operating in a manner that tends to maximize its emission level in a normal application.

3.5 Operating Condition of EUT

- 3.5.1 Setup the EUT and peripherals as shown in Sec. 3.2.
- 3.5.2 Turn on the power of all equipments and the EUT.
- 3.5.3 Set the contrast & brightness of EUT to maximum.
- 3.5.4 PC system ran the self-test program “EMC Test” by windows XP and sent “H” characters to EUT through graphic card, the EUT’s screen displayed and filled with “H” pattern by its resolution (Via HDMI Input).
- 3.5.5 PC system sent the 1kHz audio signal to EUT through audio port, the EUT speak out 1kHz audio signal.
- 3.5.6 In USB Play mode, set the EUT play digital media from U-Disk.
- 3.5.7 In LAN Play mode, set the EUT play digital media through LAN port.
- 3.5.8 The other peripherals devices were driven and operated during the test.
- 3.5.9 The test modes are as follows:

Test Mode
HDMI 1920*1080@60Hz & 1kHz playing
HDMI 1280*1024@60Hz & 1kHz playing
HDMI 640*480@60Hz & 1kHz playing
USB Play
LAN Play

3.6 Test Procedures

The EUT and peripherals were connected to the power mains through an Artificial Mains Network (AMN). This provided a 50 ohm coupling impedance for the measuring equipment.

Both sides of AC line (Line & Neutral) were checked for maximum conducted interference. In order to find the maximum emission, the relative positions of equipment and all of the interface cables were changed or manipulated according to ANSI C63.4:2003 during conducted emission test.

The bandwidth of R&S Test Receiver ESCI was set at 9 kHz.

The frequency range from 150 kHz to 30 MHz was checked.

The test modes were done on conducted disturbance test and all the test results are listed in Sec. 3.7.

3.7 Test Results

< **PASS** >

The frequency and amplitude of the highest conducted emission relative to the limit is reported. All emissions not reported below are too low against the prescribed limits.

Test Mode	Data Page
HDMI 1920*1080@60Hz & 1kHz playing	P13
HDMI 1280*1024@60Hz & 1kHz playing	P14
HDMI 640*480@60Hz & 1kHz playing	P15
USB Play	P16
LAN Play	P17

NOTE 1 – Factor = Cable Loss + AMN Factor.

NOTE 2 – Emission Level = Meter Reading + Factor.

NOTE 3 – “QP” means “Quasi-Peak” values, “AV” means “Average” values.

NOTE 4 – The worst case is for HDMI 1920*1080@60Hz & 1kHz Playing test mode. The worst emission is detected at 0.151 MHz (Average Value) with corrected signal level of 63.08 dB (μ V) (limit is 65.94 dB (μ V)), when the Line of the EUT is connected to AMN.

EUT : LED LCD TV Temperature : 22°C

Model No. : LTDN50K220WUS Humidity : 48%RH

Test Mode : HDMI 1920*1080@60Hz & 1kHz Playing Date of Test : May 12, 2015

Test Line	Frequency (MHz)	Meter Reading dB(μ V)	Factor (dB)	Emission Level dB(μ V)	Limits dB(μ V)	Margin (dB)	Remark	
Line	0.151	52.50	10.58	63.08	65.94	2.86	QP	
	0.332	27.51	10.47	37.98	59.40	21.42		
	0.666	31.80	10.43	42.23	56.00	13.77		
	1.468	31.50	10.40	41.90	56.00	14.10		
	2.522	27.89	10.45	38.34	56.00	17.66		
	6.201	34.90	10.41	45.31	60.00	14.69		
	0.151	39.80	10.58	50.38	55.94	5.56		AV
	0.332	18.91	10.47	29.38	49.40	20.02		
	0.666	23.20	10.43	33.63	46.00	12.37		
	1.468	22.30	10.40	32.70	46.00	13.30		
2.522	18.19	10.45	28.64	46.00	17.36			
6.201	26.10	10.41	36.51	50.00	13.49			
Neutral	0.150	52.30	10.58	62.88	65.98	3.10	QP	
	0.599	31.90	10.42	42.32	56.00	13.68		
	1.469	31.60	10.42	42.02	56.00	13.98		
	4.162	28.30	10.50	38.80	56.00	17.20		
	6.222	34.20	10.49	44.69	60.00	15.31		
	13.950	26.20	10.65	36.85	60.00	23.15		
	0.150	39.60	10.58	50.18	55.98	5.80	AV	
	0.599	22.40	10.42	32.82	46.00	13.18		
	1.469	22.40	10.42	32.82	46.00	13.18		
	4.162	20.80	10.50	31.30	46.00	14.70		
6.222	25.00	10.49	35.49	50.00	14.51			
13.950	21.10	10.65	31.75	50.00	18.25			

TEST ENGINEER: WENCY YANG

EUT : LED LCD TV Temperature : 22°C

Model No. : LTDN50K220WUS Humidity : 48%RH

Test Mode : HDMI 1280*1024@60Hz Date of Test : May 12, 2015
& 1kHz Playing

Test Line	Frequency (MHz)	Meter Reading dB(μ V)	Factor (dB)	Emission Level dB(μ V)	Limits dB(μ V)	Margin (dB)	Remark
Line	0.150	52.50	10.58	63.08	65.98	2.90	QP
	0.593	32.09	10.44	42.53	56.00	13.47	
	1.458	31.30	10.40	41.70	56.00	14.30	
	4.358	28.90	10.46	39.36	56.00	16.64	
	6.285	34.90	10.42	45.32	60.00	14.68	
	13.841	26.80	10.54	37.34	60.00	22.66	
	0.150	39.70	10.58	50.28	55.98	5.70	AV
	0.593	21.70	10.44	32.14	46.00	13.86	
	1.458	22.60	10.40	33.00	46.00	13.00	
	4.358	20.80	10.46	31.26	46.00	14.74	
	6.285	25.20	10.42	35.62	50.00	14.38	
13.841	21.90	10.54	32.44	50.00	17.56		
Neutral	0.150	52.10	10.58	62.68	65.98	3.30	QP
	0.330	28.91	10.46	39.37	59.45	20.08	
	0.581	31.50	10.43	41.93	56.00	14.07	
	1.474	31.90	10.42	42.32	56.00	13.68	
	2.546	28.99	10.48	39.47	56.00	16.53	
	6.280	34.49	10.50	44.99	60.00	15.01	
	0.150	39.50	10.58	50.08	55.98	5.90	AV
	0.330	19.81	10.46	30.27	49.45	19.18	
	0.581	20.00	10.43	30.43	46.00	15.57	
	1.474	23.20	10.42	33.62	46.00	12.38	
	2.546	18.89	10.48	29.37	46.00	16.63	
6.280	24.59	10.50	35.09	50.00	14.91		

TEST ENGINEER: WENCY YANG

EUT : LED LCD TV Temperature : 22°C

Model No. : LTDN50K220WUS Humidity : 48%RH

Test Mode : HDMI 640*480@60Hz & 1kHz Playing Date of Test : May 12, 2015

Test Line	Frequency (MHz)	Meter Reading dB(μ V)	Factor (dB)	Emission Level dB(μ V)	Limits dB(μ V)	Margin (dB)	Remark	
Line	0.150	52.40	10.58	62.98	65.99	3.01	QP	
	0.592	32.09	10.44	42.53	56.00	13.47		
	1.480	30.90	10.40	41.30	56.00	14.70		
	4.874	28.20	10.48	38.68	56.00	17.32		
	6.263	34.81	10.41	45.22	60.00	14.78		
	14.986	25.80	10.54	36.34	60.00	23.66		
	0.150	39.80	10.58	50.38	55.99	5.61		AV
	0.592	21.70	10.44	32.14	46.00	13.86		
	1.480	22.30	10.40	32.70	46.00	13.30		
	4.874	21.90	10.48	32.38	46.00	13.62		
6.263	25.51	10.41	35.92	50.00	14.08			
14.986	20.70	10.54	31.24	50.00	18.76			
Neutral	0.150	52.20	10.58	62.78	65.99	3.21	QP	
	0.327	28.61	10.46	39.07	59.53	20.46		
	0.592	34.60	10.43	45.03	56.00	10.97		
	2.237	28.81	10.46	39.27	56.00	16.73		
	5.995	32.40	10.48	42.88	60.00	17.12		
	13.989	26.30	10.65	36.95	60.00	23.05		
	0.150	39.60	10.58	50.18	55.99	5.81	AV	
	0.327	18.01	10.46	28.47	49.53	21.06		
	0.592	23.79	10.43	34.22	46.00	11.78		
	2.237	19.91	10.46	30.37	46.00	15.63		
5.995	25.50	10.48	35.98	50.00	14.02			
13.989	21.40	10.65	32.05	50.00	17.95			

TEST ENGINEER: WENCY YANG

EUT : LED LCD TV Temperature : 22°C

Model No. : LTDN50K220WUS Humidity : 48%RH

Test Mode : USB Play Date of Test : May 12, 2015

Test Line	Frequency (MHz)	Meter Reading dB(μV)	Factor (dB)	Emission Level dB(μV)	Limits dB(μV)	Margin (dB)	Remark
Line	0.150	52.50	10.58	63.08	65.99	2.91	QP
	0.564	31.40	10.44	41.84	56.00	14.16	
	1.470	31.90	10.40	42.30	56.00	13.70	
	4.407	28.60	10.46	39.06	56.00	16.94	
	6.291	35.10	10.42	45.52	60.00	14.48	
	17.199	26.81	10.56	37.37	60.00	22.63	
	0.150	39.80	10.58	50.38	55.99	5.61	AV
	0.564	20.90	10.44	31.34	46.00	14.66	
	1.470	23.00	10.40	33.40	46.00	12.60	
	4.407	21.00	10.46	31.46	46.00	14.54	
	6.291	25.90	10.42	36.32	50.00	13.68	
	17.199	21.61	10.56	32.17	50.00	17.83	
Neutral	0.150	52.20	10.58	62.78	65.98	3.20	QP
	0.598	32.50	10.42	42.92	56.00	13.08	
	1.459	31.70	10.42	42.12	56.00	13.88	
	1.459	31.60	10.42	42.02	56.00	13.98	
	3.328	27.50	10.49	37.99	56.00	18.01	
	6.285	34.39	10.50	44.89	60.00	15.11	
	13.408	26.29	10.65	36.94	60.00	23.06	AV
	0.150	39.60	10.58	50.18	55.98	5.80	
	0.598	23.20	10.42	33.62	46.00	12.38	
	3.328	19.40	10.49	29.89	46.00	16.11	
	6.285	25.19	10.50	35.69	50.00	14.31	
	13.408	21.19	10.65	31.84	50.00	18.16	

TEST ENGINEER: WENCY YANG

EUT : LED LCD TV Temperature : 22°C

Model No. : LTDN50K220WUS Humidity : 48%RH

Test Mode : LAN Play Date of Test : May 12, 2015

Test Line	Frequency (MHz)	Meter Reading dB(μV)	Factor (dB)	Emission Level dB(μV)	Limits dB(μV)	Margin (dB)	Remark
Line	0.151	52.50	10.58	63.08	65.97	2.89	QP
	0.586	32.20	10.44	42.64	56.00	13.36	
	2.261	30.60	10.44	41.04	56.00	14.96	
	4.874	28.80	10.48	39.28	56.00	16.72	
	6.290	34.80	10.42	45.22	60.00	14.78	
	13.710	27.30	10.54	37.84	60.00	22.16	
	0.151	39.80	10.58	50.38	55.97	5.59	AV
	0.586	21.20	10.44	31.64	46.00	14.36	
	2.261	22.30	10.44	32.74	46.00	13.26	
	4.874	22.10	10.48	32.58	46.00	13.42	
	6.290	25.90	10.42	36.32	50.00	13.68	
	13.710	22.10	10.54	32.64	50.00	17.36	
Neutral	0.150	52.20	10.58	62.78	65.99	3.21	QP
	0.585	31.50	10.43	41.93	56.00	14.07	
	1.480	30.60	10.42	41.02	56.00	14.98	
	4.822	28.70	10.53	39.23	56.00	16.77	
	6.285	34.29	10.50	44.79	60.00	15.21	
	17.568	25.30	10.69	35.99	60.00	24.01	
	0.150	39.60	10.58	50.18	55.99	5.81	AV
	0.585	21.10	10.43	31.53	46.00	14.47	
	1.480	22.10	10.42	32.52	46.00	13.48	
	4.822	21.90	10.53	32.43	46.00	13.57	
	6.285	25.19	10.50	35.69	50.00	14.31	
	17.568	20.10	10.69	30.79	50.00	19.21	

TEST ENGINEER: WENCY YANG

4 RADIATED EMISSION TEST

4.1 Test Equipment

The following test equipments are used during the radiated emission test in a semi-anechoic chamber:

Item	Type	Manufacturer	Model No.	Serial No.	Last Cal.	Next Cal.
1.	Test Receiver	R&S	ESCI	101302	Jul 03, 2014	Jul 02, 2015
2.	Preamplifier	Agilent	8447D	2944A10548	Mar 18, 2015	Sep 17, 2015
3.	Preamplifier	HP	8449B	3008A00864	May 20, 2015	May 19, 2016
4.	Bi-log Antenna	TESEQ	CBL6112D	23193	May 24, 2014	May 23, 2015
5.	Horn Antenna	EMCO	3115	9607-4878	Jun 16, 2014	Jun 15, 2015
6.	Spectrum	Agilent	E7405A	MY45106600	Jul 03, 2014	Jul 02, 2015
7.	50Ω Coaxial Switch	Anritsu	MP59B	6200426390	Mar 18, 2015	Sep 17, 2015
8.	Software	Audix	E3	6.2007-9-10	--	--

4.2 Block Diagram of Test Setup

4.2.1 EUT & Peripherals

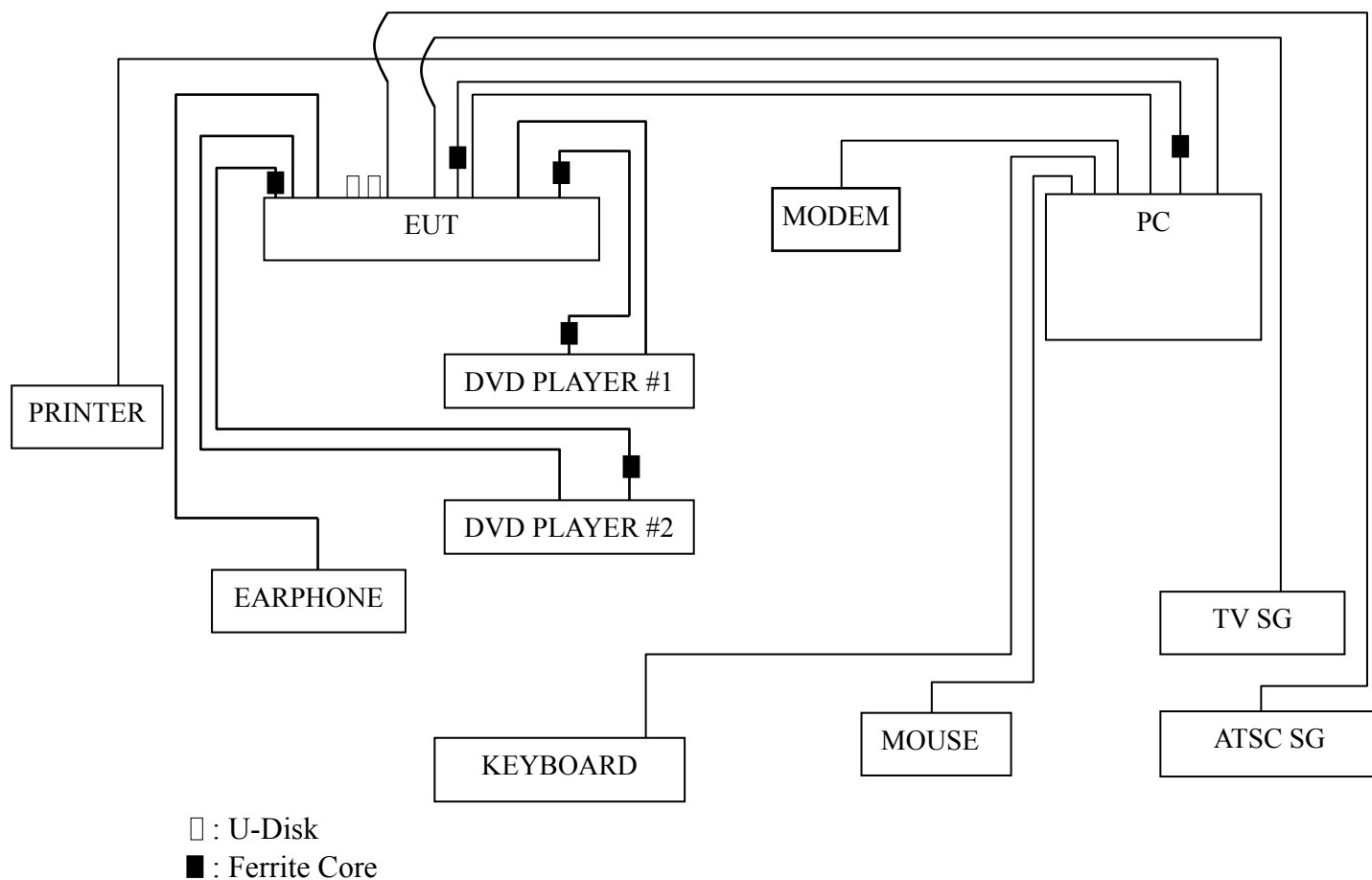

4.2.2 Radiated emission test setup

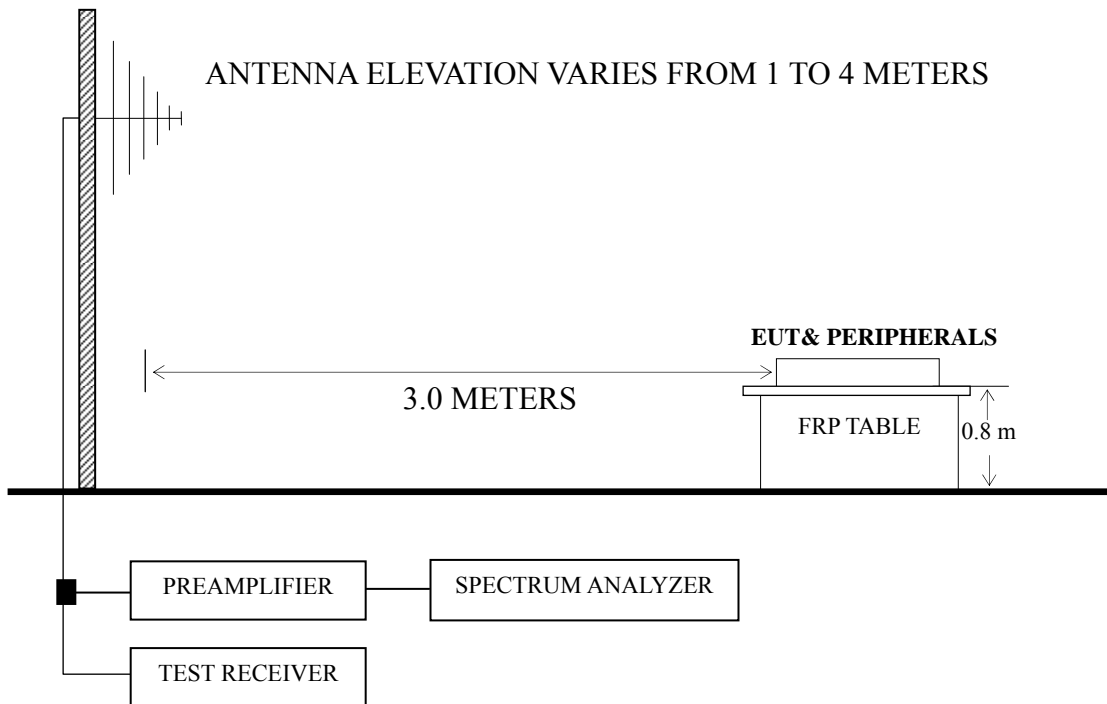

■ : 50 ohm Coaxial Switch

4.3 Radiated Emission Limit [FCC Part 15 Subpart B 15.109(a)]

Frequency (MHz)	Distance (m)	Field strength limits	
		($\mu\text{V}/\text{m}$)	dB ($\mu\text{V}/\text{m}$)
30 ~ 88	3	100	40.0
88 ~ 216	3	150	43.5
216 ~ 960	3	200	46.0
Above 960	3	500	54.0

NOTE 1 - Emission Level dB ($\mu\text{V}/\text{m}$) = 20 log Emission Level ($\mu\text{V}/\text{m}$)
 NOTE 2 - The tighter limit applies at the band edges.
 NOTE 3 - Distance refers to the distance in meters between the measuring instrument antenna and the closed point of any part of the device or system.
 NOTE 4 - The limits shown are based on Quasi-peak value detector.
 NOTE 5 - Above 1 GHz, the limit on peak emission is 20 dB above the maximum permitted average emission limit applicable to the EUT.

4.4 Test Configuration

The configuration of the EUT and peripherals are same as those used in conducted emission test.

Please refer to Sec.3.4.

4.5 Operating Condition of EUT

Same as conducted emission test which is listed in Sec.3.5, except for the test setup replaced by Sec.4.2.

4.6 Test Procedures

The EUT and peripherals were placed on a FRP turntable that is 0.8 meter above ground. The FRP turntable rotated 360 degrees to determine the position of the maximum emission level. The EUT was set 3 meters away from the receiving antenna, which was mounted on an antenna tower. Broadband antenna (Calibrated Bilog Antenna) was used as receiving antenna. The antenna moved up and down between 1 meter and 4 meters to find out the maximum emission level. Both horizontal and vertical polarizations of the antenna were set on measurement. In order to find the maximum emission, all of the interference cables were manipulated according to ANSI C63.4:2003 requirements during radiated emission test.

The I.F. bandwidth of Test Receiver R&S ESCI was set at 120 kHz.

The frequency range from 30 MHz to 1000MHz was checked for all test modes.

The frequency range from 1 GHz to 2 GHz was checked for the maximum resolution test mode.

The test modes were done on radiated disturbance test and all the test results are listed in Sec.4.7.

4.7 Test Results

<PASS>

The frequency and amplitude of the highest radiated emission relative the limit is reported. All the emissions not reported below are too low against the FCC limit.

Test Mode	Data Page
HDMI 1920*1080@60Hz & 1kHz playing	P22-P23
HDMI 1280*1024@60Hz & 1kHz playing	P24
HDMI 640*480@60Hz & 1kHz playing	P25
USB Play	P26
LAN Play	P27

- NOTE 1 – Emission Level = Antenna Factor + Cable Loss + Meter Reading. (< 1GHz);
Emission Level = Antenna Factor + Cable Loss – Preamp Factor + Meter Reading. (> 1GHz)
- NOTE 2 – All readings are Quasi-Peak values below or equal to 1GHz, Peak and Average values above 1GHz.
- NOTE 3 – 0° was the table front facing the antenna. Degree is calculated from 0° clockwise facing the antenna.
- NOTE 4 – The worst case is for HDMI 1920*1080@60Hz & 1kHz playing test mode. The worst emission at horizontal polarization was detected at 705.360 MHz with corrected signal level of 44.62 dB (μV/m) (limit is 46.00 dB (μV/m)), when the antenna was 2.10 m height and the turntable was at 339°. The worst emission at vertical polarization was detected at 32.979 MHz with corrected signal level of 35.13 dB (μV/m) (limit is 40.00 dB (μV/m)), when the antenna was 1.50m height and the turntable was at 156°.

EUT : LED LCD TV Temperature : 22°C

Model No. : LTDN50K220WUS Humidity : 60%RH

Test Mode : HDMI 1920*1080@60Hz & 1kHz Playing Date of Test : May 25, 2015

Polarization	Frequency (MHz)	Meter Reading dB (μV)	Antenna Factor (dB/m)	Cable Loss (dB)	Preamp Factor (dB)	Emission Level dB (μV/m)	Limits dB (μV/m)	Margin (dB)	Remark
Horizontal	88.033	16.50	10.46	0.93	--	27.89	43.50	15.61	QP
	148.963	19.50	11.41	1.23	--	32.14	43.50	11.36	
	226.894	26.62	8.22	1.53	--	36.37	46.00	9.63	
	296.184	25.70	11.95	1.77	--	39.42	46.00	6.58	
	396.242	17.98	17.13	2.04	--	37.15	46.00	8.85	
	705.360	20.70	21.20	2.72	--	44.62	46.00	1.38	
	1093.000	48.40	23.67	3.35	36.56	38.86	74.00	35.14	PK
	1211.000	47.20	24.36	3.55	36.38	38.73	74.00	35.27	
	1484.000	46.30	25.66	3.95	35.87	40.04	74.00	33.96	
	1677.000	50.47	26.33	4.18	35.59	45.39	74.00	28.61	
	1842.000	49.19	26.95	4.38	35.43	45.09	74.00	28.91	
	1951.000	49.63	27.27	4.49	35.34	46.05	74.00	27.95	AV
	1093.000	36.16	23.67	3.35	36.56	26.62	54.00	27.38	
	1211.000	35.01	24.36	3.55	36.38	26.54	54.00	27.46	
	1484.000	34.82	25.66	3.95	35.87	28.56	54.00	25.44	
	1677.000	39.18	26.33	4.18	35.59	34.10	54.00	19.90	
1842.000	37.81	26.95	4.38	35.43	33.71	54.00	20.29		
1951.000	38.95	27.27	4.49	35.34	35.37	54.00	18.63		

TEST ENGINEER: BILL WU

EUT : LED LCD TV Temperature : 22°C

Model No. : LTDN50K220WUS Humidity : 60%RH

Test Mode : HDMI 1920*1080@60Hz & 1kHz Playing Date of Test : May 25, 2015

Polarization	Frequency (MHz)	Meter Reading dB (μV)	Antenna Factor (dB/m)	Cable Loss (dB)	Preamp Factor (dB)	Emission Level dB (μV/m)	Limits dB (μV/m)	Margin (dB)	Remark
Vertical	32.979	18.00	16.57	0.56	--	35.13	40.00	4.87	QP
	63.983	25.85	6.60	0.79	--	33.24	40.00	6.76	
	148.963	19.59	11.41	1.23	--	32.23	43.50	11.27	
	222.170	24.90	8.05	1.50	--	34.45	46.00	11.55	
	351.708	12.84	16.13	1.94	--	30.91	46.00	15.09	
	609.200	16.80	20.40	2.53	--	39.73	46.00	6.27	
	1130.000	46.61	23.87	3.41	36.51	37.38	74.00	36.62	PK
	1267.000	46.17	24.72	3.64	36.28	38.25	74.00	35.75	
	1385.000	45.87	25.29	3.81	36.07	38.90	74.00	35.10	
	1653.000	48.94	26.24	4.15	35.63	43.70	74.00	30.30	
	1747.000	47.60	26.61	4.26	35.52	42.95	74.00	31.05	
	1838.000	48.83	26.95	4.38	35.43	44.73	74.00	29.27	
	1130.000	34.43	23.87	3.41	36.51	25.20	54.00	28.80	AV
	1267.000	33.23	24.72	3.64	36.28	25.31	54.00	28.69	
	1385.000	34.92	25.29	3.81	36.07	27.95	54.00	26.05	
	1653.000	35.75	26.24	4.15	35.63	30.51	54.00	23.49	
	1747.000	35.67	26.61	4.26	35.52	31.02	54.00	22.98	
	1838.000	36.74	26.95	4.38	35.43	32.64	54.00	21.36	

TEST ENGINEER: BILL WU

EUT : LED LCD TV Temperature : 22°C

Model No. : LTDN50K220WUS Humidity : 60%RH

Test Mode : HDMI 1280*1024@60Hz & 1kHz Playing Date of Test : May 25, 2015

Polarization	Frequency (MHz)	Meter Reading dB (μV)	Antenna Factor (dB/m)	Cable Loss (dB)	Emission Level dB (μV/m)	Limits dB (μV/m)	Margin (dB)
Horizontal	61.995	18.48	6.60	0.78	25.86	40.00	14.14
	143.830	20.47	11.50	1.21	33.18	43.50	10.32
	227.691	27.45	8.28	1.53	37.26	46.00	8.74
	296.184	28.82	11.95	1.77	42.54	46.00	3.46
	364.260	21.67	17.13	1.96	40.76	46.00	5.24
	704.720	20.60	21.20	2.72	44.52	46.00	1.48
Vertical	31.180	13.48	18.12	0.55	32.15	40.00	7.85
	63.092	24.52	6.60	0.78	31.90	40.00	8.10
	141.826	18.36	11.50	1.20	31.06	43.50	12.44
	219.075	26.03	8.00	1.49	35.52	46.00	10.48
	345.595	14.73	15.74	1.92	32.39	46.00	13.61
	599.321	16.35	18.90	2.49	37.74	46.00	8.26

TEST ENGINEER: BILL WU

EUT : LED LCD TV Temperature : 22°C

Model No. : LTDN50K220WUS Humidity : 60%RH

Test Mode : HDMI 640*480@60Hz & 1kHz Playing Date of Test : May 25, 2015

Polarization	Frequency (MHz)	Meter Reading dB (μV)	Antenna Factor (dB/m)	Cable Loss (dB)	Emission Level dB (μV/m)	Limits dB (μV/m)	Margin (dB)
Horizontal	73.103	26.58	7.62	0.85	35.05	40.00	4.95
	129.923	23.53	12.10	1.15	36.78	43.50	6.72
	207.123	26.10	8.60	1.44	36.14	43.50	7.36
	308.913	26.92	13.01	1.81	41.74	46.00	4.26
	429.523	15.23	16.70	2.13	34.06	46.00	11.94
	700.190	20.10	21.20	2.70	44.00	46.00	2.00
Vertical	39.024	25.78	11.08	0.61	37.47	40.00	2.53
	73.103	25.83	7.62	0.85	34.30	40.00	5.70
	129.923	27.16	12.10	1.15	40.41	43.50	3.09
	204.955	27.49	8.80	1.44	37.73	43.50	5.77
	308.913	25.06	13.01	1.81	39.88	46.00	6.12
	616.372	10.56	21.07	2.53	34.16	46.00	11.84

TEST ENGINEER: BILL WU

EUT : LED LCD TV Temperature : 22°C

Model No. : LTDN50K220WUS Humidity : 60%RH

Test Mode : USB Play Date of Test : May 25, 2015

Polarization	Frequency (MHz)	Meter Reading dB (μ V)	Antenna Factor (dB/m)	Cable Loss (dB)	Emission Level dB (μ V/m)	Limits dB (μ V/m)	Margin (dB)
Horizontal	54.071	15.82	6.50	0.72	23.04	40.00	16.96
	83.816	14.68	9.79	0.91	25.38	40.00	14.62
	129.015	18.53	12.12	1.15	31.80	43.50	11.70
	187.753	18.35	9.14	1.37	28.86	43.50	14.64
	293.084	23.17	11.62	1.76	36.55	46.00	9.45
	438.655	15.67	16.80	2.14	34.61	46.00	11.39
Vertical	34.760	15.31	15.16	0.58	31.05	40.00	8.95
	61.778	21.18	6.60	0.78	28.56	40.00	11.44
	120.277	17.09	11.93	1.10	30.12	43.50	13.38
	234.168	18.64	8.80	1.56	29.00	46.00	17.00
	382.588	14.69	17.48	2.02	34.19	46.00	11.81
	588.905	10.57	17.20	2.47	30.24	46.00	15.76

TEST ENGINEER: BILL WU

EUT : LED LCD TV Temperature : 22°C

Model No. : LTDN50K220WUS Humidity : 60%RH

Test Mode : LAN Play Date of Test : May 25, 2015

Polarization	Frequency (MHz)	Meter Reading dB (μ V)	Antenna Factor (dB/m)	Cable Loss (dB)	Emission Level dB (μ V/m)	Limits dB (μ V/m)	Margin (dB)
Horizontal	73.359	19.79	7.69	0.85	28.33	40.00	11.67
	127.218	18.41	12.16	1.14	31.71	43.50	11.79
	176.269	21.72	9.56	1.33	32.61	43.50	10.89
	225.308	24.42	8.10	1.52	34.04	46.00	11.96
	292.058	29.84	11.45	1.76	43.05	46.00	2.95
	406.088	12.59	16.95	2.07	31.61	46.00	14.39
Vertical	32.864	17.10	16.63	0.56	34.29	40.00	5.71
	46.340	21.29	9.64	0.66	31.59	40.00	8.41
	80.081	18.92	9.00	0.89	28.81	40.00	11.19
	138.387	22.86	11.70	1.18	35.74	43.50	7.76
	267.546	17.58	9.80	1.68	29.06	46.00	16.94
	383.932	13.53	17.47	2.02	33.02	46.00	12.98

TEST ENGINEER: BILL WU

5 DEBUG DESCRIPTION

The following components are used during the countermeasure procedures:

Name	M/N	Manufacturer	Location
Conductive Tape	5X30MM\ROH	Qingdao Joinset Co., Ltd	See Appendix Figure 22, 23, 24, 25

Note: We had required the applicant and manufacturer that all electrical and mechanical devices employed for spurious radiation suppression, including any modifications made during certification testing, must be incorporated in each unit marked

TEST ENGINEER:

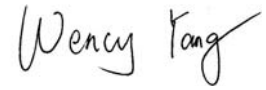

(WENCY YANG)

6 DEVIATION TO TEST SPECIFICATIONS

None.