

Application for FCC Certificate
On Behalf of
Hisense Electric Co., Ltd.

LED LCD TV

Model No.	Brand
50K25DGW, 50H4, 50H4G, 50H4C	Hisense

FCC ID : W9HLCDF0045

Prepared For : Hisense Electric Co., Ltd.
No.218 Qianwangang Road, Economy & Technology
Development Zone, Qingdao, China

Prepared By : Audix Technology (Shanghai) Co., Ltd.
3F and 4F, 34Bldg 680 Guiping Rd,
Caohejing Hi-Tech Park,
Shanghai 200233, China

Tel: +86-21-64955500
Fax: +86-21-64955491

Report No. : ACI-F14110
Date of Test : Jun 29 – Jul 03, 2014
Date of Report : Jul 17, 2014

TABLE OF CONTENTS

	Page
1 SUMMARY OF STANDARDS AND RESULTS.....	4
1.1 Description of Standards and Results.....	4
2 GENERAL INFORMATION.....	5
2.1 Description of Equipment Under Test.....	5
2.2 Peripherals.....	6
2.3 Description of Test Facility.....	8
2.4 Measurement Uncertainty.....	8
3 CONDUCTED EMISSION TEST.....	9
3.1 Test Equipment.....	9
3.2 Block Diagram of Test Setup.....	9
3.3 Conducted Emission Limit [FCC Part 15 Subpart B 15.107(a)].....	10
3.4 Test Configuration.....	10
3.5 Operating Condition of EUT.....	11
3.6 Test Procedures.....	11
3.7 Test Results.....	12
4 RADIATED EMISSION TEST.....	17
4.1 Test Equipment.....	17
4.2 Block Diagram of Test Setup.....	17
4.3 Radiated Emission Limit [FCC Part 15 Subpart B 15.109(a)].....	18
4.4 Test Configuration.....	18
4.5 Operating Condition of EUT.....	18
4.6 Test Procedures.....	19
4.7 Test Results.....	19
5 DEVIATION TO TEST SPECIFICATIONS.....	26

TEST REPORT FOR FCC CERTIFICATE

Applicant : Hisense Electric Co., Ltd.
 Manufacturer : Hisense Electric Co., Ltd.
 Factory #1 : Hisense Electric Co., Ltd.
 Factory #2 : Tatung Mexico S.A. de C.V.
 EUT Description : LED LCD TV

Model No.	Brand	Power Supply
50K25DGW, 50H4, 50H4G, 50H4C	Hisense	120V/60Hz

Test Procedure Used:

*FCC RULES AND REGULATIONS PART 15 SUBPART B CLASS B OCTOBER 2013
AND ANSI C63.4-2003*

The device described above is tested by Audix Technology (Shanghai) Co., Ltd. to determine the maximum emission levels emanating from the device. The maximum emission levels are compared to the FCC Part 15 Subpart B (Class B) limits both radiated and conducted emissions.

The test results are contained in this test report and Audix Technology (Shanghai) Co., Ltd. is assumed full responsibility for the accuracy and completeness of these measurements. This report shows that the EUT (M/N: Refer to Sec2.1) which was tested in 3m anechoic chamber Jun 29 – Jul 03, 2014 is technically compliance with the FCC official limits also.

This report applies to above tested sample only. This report shall not be reproduced in part without written approval of Audix Technology (Shanghai) Co., Ltd.

This report contains data that are not covered by the NVLAP accreditation.

This report must not be used by the client to claim product certification, approval, or endorsement by NVLAP, NIST, or any agency of the federal government.

The test results for EUT's TV functions are contained in No.F14109, a Verification report.

Date of Test : Jun 29 – Jul 03, 2014 Date of Report : Jul 17, 2014

Producer : 
 EMILY ZHU / Assistant

Review : 
 DIO YANG / Deputy Manager

 For and on behalf of
 Audix Technology (Shanghai) Co., Ltd.

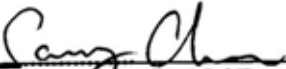
Signatory : 
 Authorized Signature EMC SAMMY CHEN / Deputy Manager

1 SUMMARY OF STANDARDS AND RESULTS

1.1 Description of Standards and Results

The EUT have been tested according to the applicable standards as referenced below:

Description of Test Item	Standard	Limits	Results
EMISSION			
Conducted Disturbance at the Mains Terminal	FCC RULES AND REGULATIONS PART 15 SUBPART B OCTOBER 2013 AND ANSI C63.4-2003	15.107(a) Class B	Pass
Radiated Disturbance	FCC RULES AND REGULATIONS PART 15 SUBPART B OCTOBER 2013 AND ANSI C63.4-2003	15.109(a) Class B	Pass

2 GENERAL INFORMATION

2.1 Description of Equipment Under Test

Description	:	LED LCD TV
Type of EUT	:	<input checked="" type="checkbox"/> Production <input type="checkbox"/> Pre-product <input type="checkbox"/> Pro-type
Model No.	:	50K25DGW, 50H4, 50H4G, 50H4C
Note	:	The above models are all the same except for model name. 50H4 model is tested and recorded in the report.
Brand Name	:	Hisense
Applicant	:	Hisense Electric Co., Ltd. No.218 Qianwangang Road, Economy & Technology Development Zone, Qingdao, China
Manufacturer	:	Hisense Electric Co., Ltd. No.218 Qianwangang Road, Economy & Technology Development Zone, Qingdao, China
Factory #1	:	Hisense Electric Co., Ltd. No.218 Qianwangang Road, Economy & Technology Development Zone, Qingdao, China
Factory #2	:	Tatung Mexico S.A. de C.V. Miguel Catalán 420, Parque Industrial Rio Bravo, Cd. Juarez, Chih., CP 32557
LCD Panel	:	Manufacturer : Hisense M/N : HD500DF-B57(010)
Max Resolution	:	1920*1080@60Hz
HDMI Cable	:	Shielded, Detachable, 1.00m
Power Cord	:	Unshielded, Detachable, 1.80m

Remark:

The EUT is a LED LCD TV which input/output ports as follows:

Bottom Port:

- (1) One USB Port : Connected with U-Disk
- (2) One HDMI3 Port : Connected with DVD PLAYER#2
- (3) One HDMI2(ARC) Port : Connected with DVD PLAYER#1

Side Port:

- (4) One HDMI1 Port : Connected with PC
- (5) One Ant/Cable Port : Connected with Antenna or ATSC SG / TV SG
- (6) One Earphone/AUDIO OUT Port : Connected with Earphone
- (7) One DIGITAL AUDIO OUT Port : Connected with DVD PLAYER #2
- (8) One component of AV IN Port : Connected with DVD PLAYER#1

2.2 Peripherals

2.2.1 PC

Manufacturer : HP
 Model Number : dx7200MT
 Serial Number : CNG622017W
 Power Cord : Unshielded, Detachable, 1.8m
 Certificate : FCC DoC; CE/EMC; VCCI; C-Tick; BSMI, 3C, MIC

2.2.2 Printer

Manufacturer : HP
 Model Number : C3990A
 Serial Number : JPZX020487
 Data Cable : Shielded, detachable, 1.5m
 Certificate : GS, CE/EMC, C-Tick, FCC DoC

2.2.3 Keyboard

Manufacturer : Microsoft
 Model Number : RT2300
 Serial Number : 7668200662248
 Data Cable : Shielded, Undetachable ,1.8m
 Certificate : CE/EMC, FCC DoC, VCCI, MIC, C-Tick, BSMI

2.2.4 Mouse

Manufacturer : Microsoft
Model Number : RT2300
Serial Number : 6965712071551
Data Cable : Shielded, Undetachable, 1.8m.
Certificate : CE/EMC, FCC DoC, VCCI, MIC, C-Tick,
BSMI

2.2.5 Modem

Manufacturer : TP-LINK
Model Number : TM-EC5658V
Serial Number : 07123301053
Data Cable : Shielded, Detachable, 1.8m
Certificate : FCC DoC, CE/EMC, CCC

2.2.6 TV Signal Generator

Manufacturer : FLUKE
Model Number : 54200m01
Serial Number : 814008
Data Cable : Shielded, detachable, 2.0m
Power Cord : Unshielded, detachable, 2.0m
Certificate : CE/EMC, FCC DoC, CCC

2.2.7 ATSC Signal Generator

Manufacturer : SENCORE
Model Number : ATSC997
Serial Number : 6790071

2.2.8 DVD PLAYER#1

Manufacturer : PHILIPS
Model Number : DVP3986K/93
Serial Number : KX1A0902120108
Certificate : FCC DoC, CE/EMC, CCC

2.2.9 DVD PLAYER #2

Manufacturer : PHILIPS
Model Number : DVP3986K/93
Serial Number : KX1A0902120082
Certificate : FCC DoC, CE/EMC, CCC

2.2.10 Earphone#1

Manufacturer : audio-technica
Model Number : ATH-CKL200

2.2.11 Earphone#2

Manufacturer : Skullcandy
Model Number : FMJ

2.2.12 U-DISK

Manufacturer : LG
Model Number : 1GB

2.3 Description of Test Facility

Site Description (No.3 3m Chamber)	:	Sept. 17, 1998 file on Mar 16, 2012 Renewed Federal Communications Commission FCC Engineering Laboratory 7435 Oakland Mills Road Columbia, MD 21046, USA
Name of Firm	:	Audix Technology (Shanghai) Co., Ltd.
Site Location	:	3F 34Bldg 680 Guiping Rd, Caohejing Hi-Tech Park, Shanghai 200233, China
NVLAP Lab Code	:	200371-0

2.4 Measurement Uncertainty

Conducted Emission Expanded Uncertainty:	U = 3.02 dB
Radiated Emission Expanded Uncertainty (30-200MHz):	U = 4.17 dB (Horizontal) U = 4.02 dB (Vertical)
Radiated Emission Expanded Uncertainty (200M-1GHz):	U = 3.38 dB (Horizontal) U = 3.28 dB (Vertical)
Radiated Emission Expanded Uncertainty (Above 1GHz):	U = 4.68 dB (Horizontal) U = 4.87 dB (Vertical)

3 CONDUCTED EMISSION TEST

3.1 Test Equipment

The following test equipments are used during the conducted emission test in a shielded room:

Item	Type	Manufacturer	Model No.	Serial No.	Last Cal.	Next Cal.
1.	Test Receiver	R&S	ESCI	100841	Mar 20, 2014	Mar 19, 2015
2.	Artificial Mains Network (AMN)	R&S	ESH2-Z5	843890/011	Feb 25, 2014	Feb 24, 2015
3.	Line Impedance Stabilization Network (LISN)	Kyoritsu	KNW-407	8-1280-4	Mar 20, 2014	Mar 19, 2015
4.	50 Ω Coaxial Switch	Anritsu	MP59B	6200426389	Mar 18, 2014	Sep 17, 2014
5.	50 Ω Terminator	Anritsu	BNC	001	Mar 20, 2014	Mar 19, 2015
6.	Software	Audix	E3	6.2009-1-15	--	--

3.2 Block Diagram of Test Setup

3.2.1 EUT & Peripherals

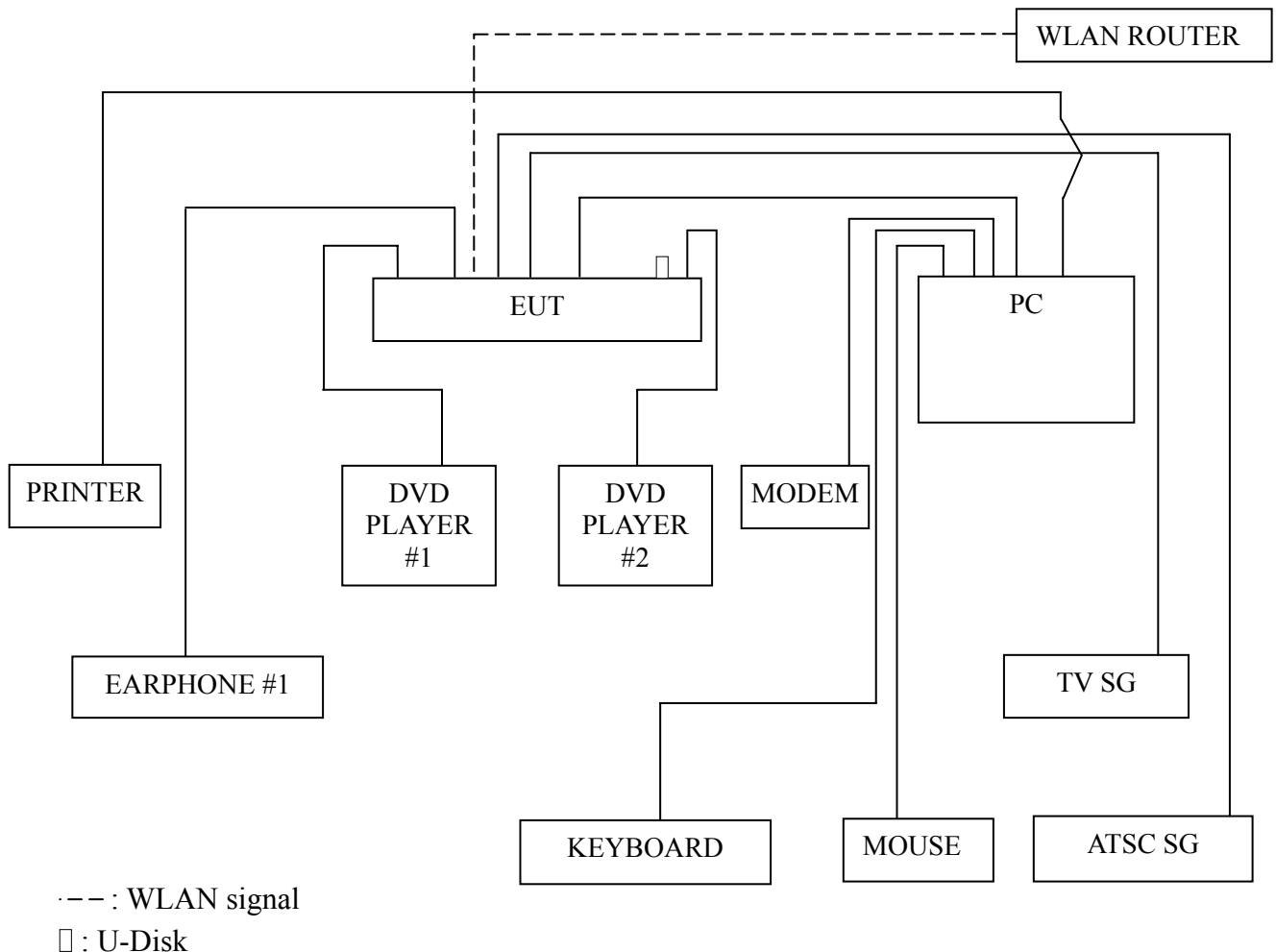

3.2.2 Conducted Disturbance Test Setup

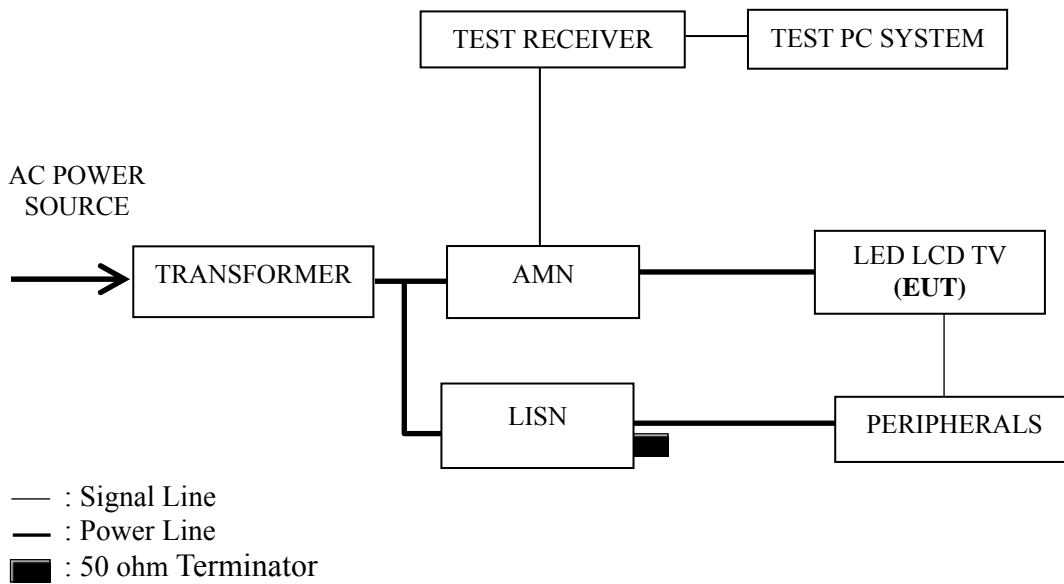

3.3 Conducted Emission Limit [FCC Part 15 Subpart B 15.107(a)]

Frequency Range (MHz)	Limits dB (μ V)	
	Quasi-peak	Average
0.15 ~ 0.5	66~56	56~46
0.5 ~ 5	56	46
5 ~ 30	60	50

NOTE 1 – The lower limit shall apply at the transition frequencies.
 NOTE 2 – The limit decreases linearly with the logarithm of the frequency in the range 0.15 MHz~0.50 MHz

3.4 Test Configuration

The EUT (listed in Sec.2.1) and the peripherals (listed in Sec 2.2) were installed as shown on Sec.3.2 to meet FCC requirement and operating in a manner that tends to maximize its emission level in a normal application.

3.5 Operating Condition of EUT

- 3.5.1 Setup the EUT and peripherals as shown in Sec. 3.2.
- 3.5.2 Turn on the power of all equipments and the EUT.
- 3.5.3 Set the contrast & brightness of EUT to maximum.
- 3.5.4 PC system ran the self-test program “EMC Test” by windows XP and sent “H” characters to EUT through graphic card, the EUT’s screen displayed and filled with “H” pattern by its resolution (Via HDMI Input).
- 3.5.5 In USB Play mode, set the EUT play digital media from U-Disk.
- 3.5.6 The WLAN function is operating to communicate with WLAN router.
- 3.5.7 The other peripherals devices were driven and operated during the test.
- 3.5.8 The test modes are as follows:

Test Mode
HDMI 1920*1080@60Hz
HDMI 1280*1024@60Hz
HDMI 640*480@60Hz
USB Play

3.6 Test Procedures

The EUT and peripherals were connected to the power mains through an Artificial Mains Network (AMN). This provided a 50 ohm coupling impedance for the measuring equipment.

Both sides of AC line (Line & Neutral) were checked for maximum conducted interference. In order to find the maximum emission, the relative positions of equipment and all of the interface cables were changed or manipulated according to ANSI C63.4:2003 during conducted emission test.

The bandwidth of R&S Test Receiver ESCI was set at 9 kHz.

The frequency range from 150 kHz to 30 MHz was checked.

The test modes were done on conducted disturbance test and all the test results are listed in Sec. 3.7.

3.7 Test Results

< **PASS** >

The frequency and amplitude of the highest conducted emission relative to the limit is reported. All emissions not reported below are too low against the prescribed limits.

Test Mode	Data Page
HDMI 1920*1080@60Hz	P13
HDMI1280*1024@60Hz	P14
HDMI 640*480@60Hz	P15
USB Play	P16

NOTE 1 – Factor = Cable Loss + AMN Factor.

NOTE 2 – Emission Level = Meter Reading + Factor.

NOTE 3 – “QP” means “Quasi-Peak” values, “AV” means “Average” values.

NOTE 4 – The worst case is for HDMI 1920*1080@60Hz test mode. The worst emission is detected at 23.970 MHz (Average Value) with corrected signal level of 39.90 dB (μ V) (limit is 50.00 dB (μ V)), when the Line of the EUT is connected to AMN.

EUT : LED LCD TV Temperature : 22

Model No. : 50H4 Humidity : 48%RH

Test Mode : HDMI 1920*1080@60Hz Date of Test : Jul 03, 2014

Test Line	Frequency (MHz)	Meter Reading dB(μ V)	Factor (dB)	Emission Level dB(μ V)	Limits dB(μ V)	Margin (dB)	Remark
Line	0.164	47.60	0.14	47.74	65.25	17.51	QP
	0.558	39.50	0.00	39.50	56.00	16.50	
	0.944	40.20	0.06	40.26	56.00	15.74	
	1.489	39.50	0.06	39.56	56.00	16.44	
	2.855	37.89	0.12	38.01	56.00	17.99	
	23.970	49.30	-0.40	48.90	60.00	11.10	
	0.164	35.50	0.14	35.64	55.25	19.61	AV
	0.558	29.20	0.00	29.20	46.00	16.80	
	0.944	31.10	0.06	31.16	46.00	14.84	
	1.489	29.60	0.06	29.66	46.00	16.34	
	2.855	26.19	0.12	26.31	46.00	19.69	
	23.970	40.30	-0.40	39.90	50.00	10.10	
Neutral	0.181	47.29	0.19	47.48	64.45	16.97	QP
	0.558	39.61	0.17	39.78	56.00	16.22	
	1.209	39.30	0.17	39.47	56.00	16.53	
	1.753	38.30	0.17	38.47	56.00	17.53	
	3.101	37.59	0.19	37.78	56.00	18.22	
	23.860	45.90	0.88	46.78	60.00	13.22	
	0.181	35.09	0.19	35.28	54.45	19.17	AV
	0.558	28.91	0.17	29.08	46.00	16.92	
	1.209	29.50	0.17	29.67	46.00	16.33	
	1.753	26.30	0.17	26.47	46.00	19.53	
	3.101	25.99	0.19	26.18	46.00	19.82	
	23.860	37.60	0.88	38.48	50.00	11.52	

TEST ENGINEER: ERIC TANG

EUT : LED LCD TV Temperature : 22

Model No. : 50H4 Humidity : 48%RH

Test Mode : HDMI 1280*1024@60Hz Date of Test : Jul 03, 2014

Test Line	Frequency (MHz)	Meter Reading dB(μ V)	Factor (dB)	Emission Level dB(μ V)	Limits dB(μ V)	Margin (dB)	Remark
Line	0.158	48.10	0.15	48.25	65.58	17.33	QP
	0.680	39.80	0.09	39.89	56.00	16.11	
	1.489	39.30	0.06	39.36	56.00	16.64	
	2.567	37.80	0.09	37.89	56.00	18.11	
	13.720	39.50	0.03	39.53	60.00	20.47	
	23.980	45.80	-0.40	45.40	60.00	14.60	
	0.158	35.90	0.15	36.05	55.58	19.53	AV
	0.680	31.20	0.09	31.29	46.00	14.71	
	1.489	29.40	0.06	29.46	46.00	16.54	
	2.567	25.10	0.09	25.19	46.00	20.81	
	13.720	34.20	0.03	34.23	50.00	15.77	
	23.980	37.90	-0.40	37.50	50.00	12.50	
Neutral	0.159	47.50	0.16	47.66	65.53	17.87	QP
	0.379	41.90	0.21	42.11	58.31	16.20	
	0.667	37.80	0.13	37.93	56.00	18.07	
	1.209	39.90	0.17	40.07	56.00	15.93	
	2.304	38.60	0.17	38.77	56.00	17.23	
	23.990	44.50	0.88	45.38	60.00	14.62	
	0.159	34.70	0.16	34.86	55.53	20.67	AV
	0.379	29.10	0.21	29.31	48.31	19.00	
	0.667	27.70	0.13	27.83	46.00	18.17	
	1.209	30.00	0.17	30.17	46.00	15.83	
	2.304	27.50	0.17	27.67	46.00	18.33	
	23.990	35.30	0.88	36.18	50.00	13.82	

TEST ENGINEER: ERIC TANG

EUT : LED LCD TV Temperature : 22

Model No. : 50H4 Humidity : 48%RH

Test Mode : HDMI 640*480@60Hz Date of Test : Jul 03, 2014

Test Line	Frequency (MHz)	Meter Reading dB(μ V)	Factor (dB)	Emission Level dB(μ V)	Limits dB(μ V)	Margin (dB)	Remark
Line	0.158	48.10	0.15	48.25	65.59	17.34	QP
	0.554	39.81	-0.01	39.80	56.00	16.20	
	1.479	39.30	0.06	39.36	56.00	16.64	
	4.202	37.00	0.18	37.18	56.00	18.82	
	13.760	39.40	0.03	39.43	60.00	20.57	
	23.940	43.70	-0.40	43.30	60.00	16.70	
	0.158	35.80	0.15	35.95	55.59	19.64	AV
	0.554	30.01	-0.01	30.00	46.00	16.00	
	1.479	29.20	0.06	29.26	46.00	16.74	
	4.202	25.20	0.18	25.38	46.00	20.62	
	13.760	33.60	0.03	33.63	50.00	16.37	
	23.940	35.90	-0.40	35.50	50.00	14.50	
Neutral	0.158	47.60	0.16	47.76	65.57	17.81	QP
	0.377	41.80	0.21	42.01	58.36	16.35	
	0.673	39.41	0.12	39.53	56.00	16.47	
	1.491	39.60	0.17	39.77	56.00	16.23	
	13.640	40.61	0.50	41.11	60.00	18.89	
	23.960	44.20	0.88	45.08	60.00	14.92	
	0.158	34.30	0.16	34.46	55.57	21.11	AV
	0.377	29.30	0.21	29.51	48.36	18.85	
	0.673	31.91	0.12	32.03	46.00	13.97	
	1.491	29.30	0.17	29.47	46.00	16.53	
	13.640	35.51	0.50	36.01	50.00	13.99	
	23.960	35.40	0.88	36.28	50.00	13.72	

TEST ENGINEER: ERIC TANG

EUT : LED LCD TV Temperature : 22

Model No. : 50H4 Humidity : 48%RH

Test Mode : USB Play Date of Test : Jul 03, 2014

Test Line	Frequency (MHz)	Meter Reading dB(μ V)	Factor (dB)	Emission Level dB(μ V)	Limits dB(μ V)	Margin (dB)	Remark
Line	0.160	48.20	0.15	48.35	65.49	17.14	QP
	0.679	39.80	0.09	39.89	56.00	16.11	
	1.211	40.30	0.05	40.35	56.00	15.65	
	3.390	37.90	0.14	38.04	56.00	17.96	
	13.510	40.20	0.04	40.24	60.00	19.76	
	23.920	43.40	-0.40	43.00	60.00	17.00	
	0.160	36.80	0.15	36.95	55.49	18.54	AV
	0.679	31.60	0.09	31.69	46.00	14.31	
	1.211	30.40	0.05	30.45	46.00	15.55	
	3.390	25.80	0.14	25.94	46.00	20.06	
	13.510	34.90	0.04	34.94	50.00	15.06	
	23.920	35.60	-0.40	35.20	50.00	14.80	
Neutral	0.171	47.50	0.17	47.67	64.92	17.25	QP
	0.378	41.90	0.21	42.11	58.32	16.21	
	0.680	39.90	0.12	40.02	56.00	15.98	
	1.220	40.10	0.17	40.27	56.00	15.73	
	2.832	37.89	0.18	38.07	56.00	17.93	
	13.590	41.50	0.50	42.00	60.00	18.00	
	0.171	33.00	0.17	33.17	54.92	21.75	AV
	0.378	29.10	0.21	29.31	48.32	19.01	
	0.680	31.50	0.12	31.62	46.00	14.38	
	1.220	30.60	0.17	30.77	46.00	15.23	
	2.832	26.19	0.18	26.37	46.00	19.63	
	13.590	37.40	0.50	37.90	50.00	12.10	

TEST ENGINEER: ERIC TANG

4 RADIATED EMISSION TEST

4.1 Test Equipment

The following test equipments are used during the radiated emission test in a semi-anechoic chamber:

Item	Type	Manufacturer	Model No.	Serial No.	Last Cal.	Next Cal.
1.	Test Receiver	R&S	ESCI	101302	Sep 03, 2013	Sep 02, 2014
2.	Preamplifier	Agilent	8447D	2944A10548	Mar 18, 2014	Sep 17, 2014
3.	Preamplifier	HP	8449B	3008A00864	Mar 20, 2014	Mar 19, 2015
4.	Bi-log Antenna	TESEQ	CBL6112D	23193	May 03, 2014	May 02, 2015
5.	Horn Antenna	EMCO	3115	9607-4878	May 11, 2014	May 10, 2015
6.	Spectrum	Agilent	E7405A	MY45106600	Nov 11, 2013	Nov 10, 2014
7.	50 Coaxial Switch	Anritsu	MP59B	6200426390	Mar 18, 2014	Sep 17, 2014
8.	Software	Audix	E3	6.2007-9-10	--	--

4.2 Block Diagram of Test Setup

4.2.1 EUT & Peripherals

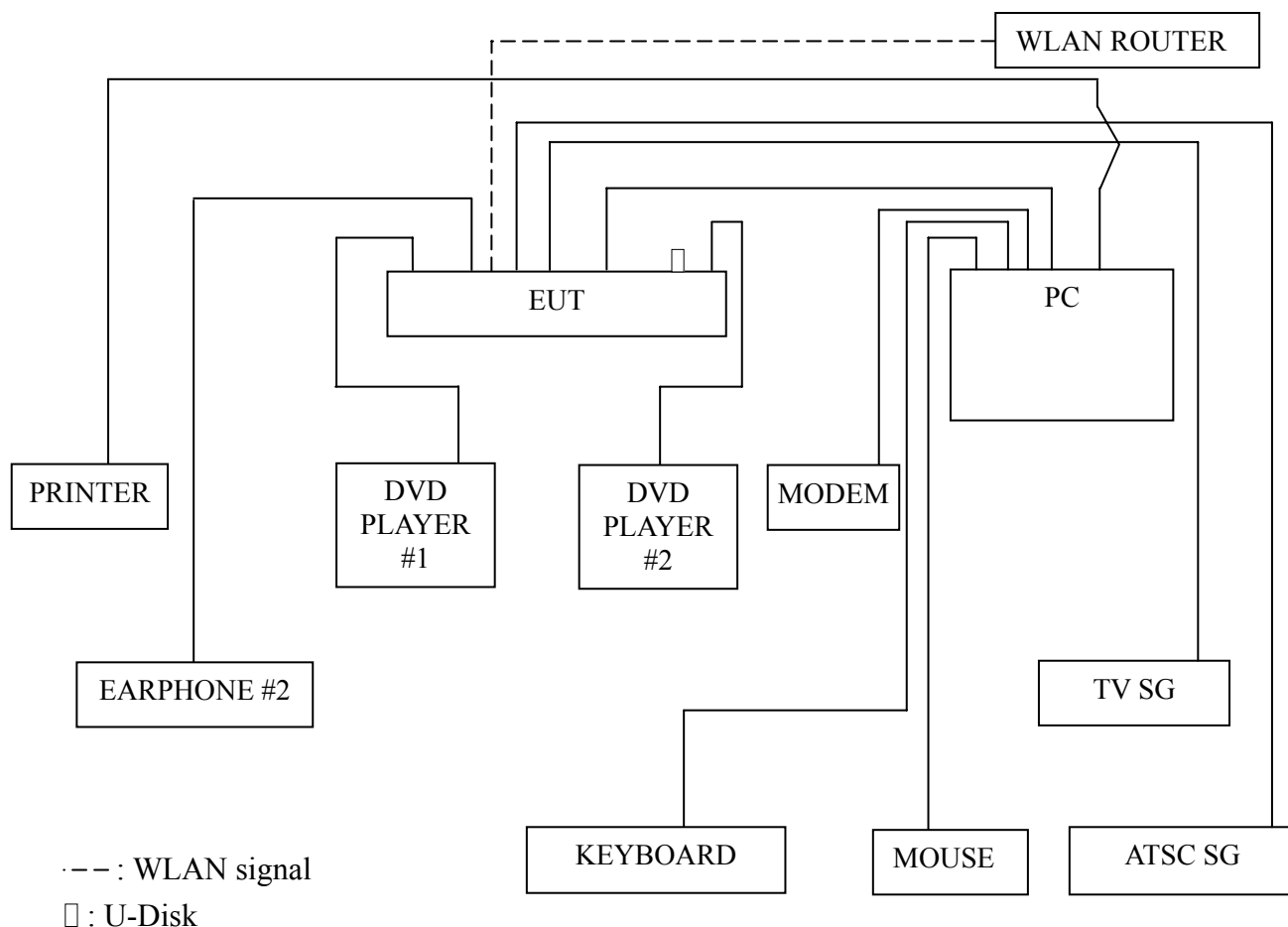

4.2.2 Radiated emission test setup

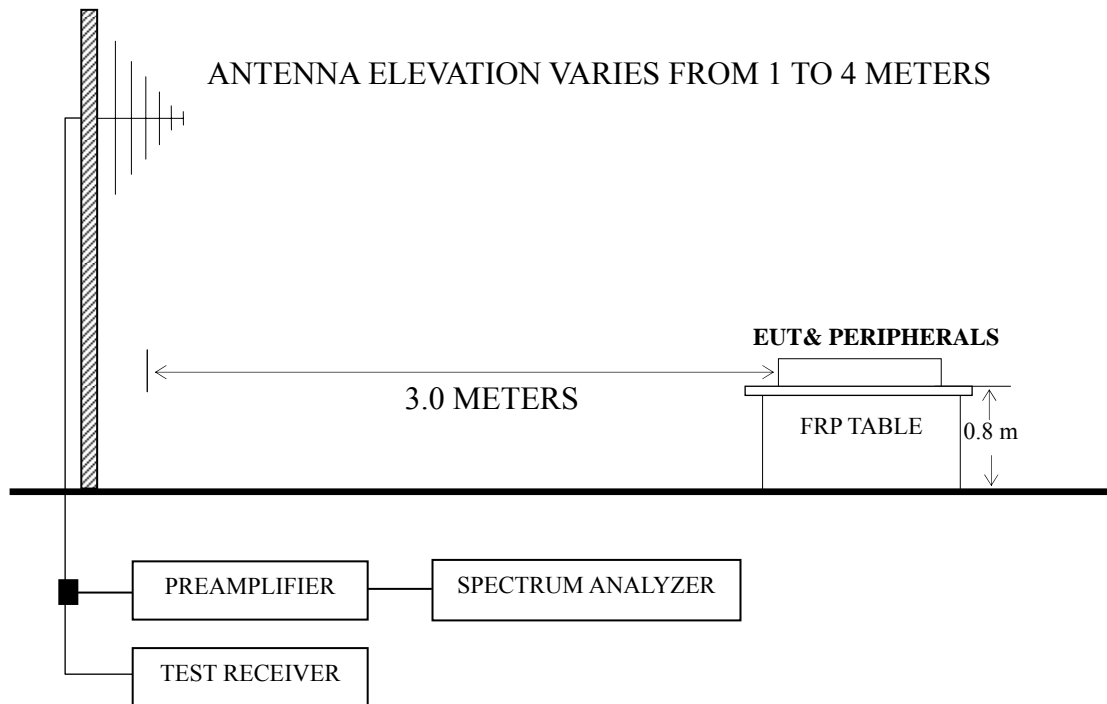

■ : 50 ohm Coaxial Switch

4.3 Radiated Emission Limit [FCC Part 15 Subpart B 15.109(a)]

Frequency (MHz)	Distance (m)	Field strength limits	
		($\mu\text{V/m}$)	dB ($\mu\text{V/m}$)
30 ~ 88	3	100	40.0
88 ~ 216	3	150	43.5
216 ~ 960	3	200	46.0
Above 960	3	500	54.0

NOTE 1 - Emission Level dB ($\mu\text{V/m}$) = 20 log Emission Level ($\mu\text{V/m}$)

NOTE 2 - The tighter limit applies at the band edges.

NOTE 3 - Distance refers to the distance in meters between the measuring instrument antenna and the closed point of any part of the device or system.

NOTE 4 - The limits shown are based on Quasi-peak value detector.

NOTE 5 - Above 1 GHz, the limit on peak emission is 20 dB above the maximum permitted average emission limit applicable to the EUT.

4.4 Test Configuration

The configuration of the EUT and peripherals are same as those used in conducted emission test.

Please refer to Sec.3.4.

4.5 Operating Condition of EUT

Same as conducted emission test which is listed in Sec.3.5, except for the test setup replaced by Sec.4.2.

4.6 Test Procedures

The EUT and peripherals were placed on a FRP turntable that is 0.8 meter above ground. The FRP turntable rotated 360 degrees to determine the position of the maximum emission level. The EUT was set 3 meters away from the receiving antenna, which was mounted on an antenna tower. Broadband antenna (Calibrated Bilog Antenna) was used as receiving antenna. The antenna moved up and down between 1 meter and 4 meters to find out the maximum emission level. Both horizontal and vertical polarizations of the antenna were set on measurement. In order to find the maximum emission, all of the interference cables were manipulated according to ANSI C63.4:2003 requirements during radiated emission test.

The I.F. bandwidth of Test Receiver R&S ESCI was set at 120 kHz.

The frequency range from 30 MHz to 1000MHz was checked for all test modes.

The frequency range from 1 GHz to 24 GHz (10th harmonic of the 2.4GHz RF function) was checked for the worst emission test mode.

The test modes were done on radiated disturbance test and all the test results are listed in Sec.4.7.

4.7 Test Results

<PASS>

The frequency and amplitude of the highest radiated emission relative the limit is reported. All the emissions not reported below are too low against the FCC limit.

Test Mode	Data Page
HDMI 1920*1080@60Hz	P21 – P22
HDMI 1280*1024@60Hz	P23
HDMI 640*480@60Hz	P24
USB Play	P25

NOTE 1 – Emission Level = Antenna Factor + Cable Loss + Meter Reading. (< 1GHz);

Emission Level = Antenna Factor + Cable Loss – Preamp Factor + Meter Reading. (> 1GHz)

NOTE 2 – All readings are Quasi-Peak values below or equal to 1GHz, Peak and Average values above 1GHz.

NOTE 3 – 0° was the table front facing the antenna. Degree is calculated from 0° clockwise facing the antenna.

NOTE 4 – The worst case is for HDMI 1920*1080@60Hz test mode. The worst emission at horizontal polarization was detected at 734.491 MHz with corrected signal level of 42.90 dB ($\mu\text{V}/\text{m}$) (limit is 46.00 dB ($\mu\text{V}/\text{m}$)), when the antenna was 1.70 m height and the turntable was at 295°. The worst emission at vertical polarization was detected at 292.058 MHz with corrected signal level of 42.46 dB ($\mu\text{V}/\text{m}$) (limit is 46.00 dB ($\mu\text{V}/\text{m}$)), when the antenna was 1.40 m height and the turntable was at 0°.

EUT : LED LCD TV Temperature : 22

Model No. : 50H4 Humidity : 60%RH

Test Mode : HDMI 1920*1080@60Hz Date of Test : Jun 29, 2014

Polarization	Frequency (MHz)	Meter Reading dB (μ V)	Antenna Factor (dB/m)	Cable Loss (dB)	Preamp Factor (dB)	Emission Level dB (μ V/m)	Limits dB (μ V/m)	Margin (dB)	Remark
Horizontal	95.093	25.17	9.39	1.29	--	35.85	43.50	7.65	QP
	140.835	25.22	10.30	1.60	--	37.12	43.50	6.38	
	213.763	27.49	7.60	2.01	--	37.10	43.50	6.40	
	292.058	27.54	12.75	2.49	--	42.78	46.00	3.22	
	734.491	20.23	19.10	3.57	--	42.90	46.00	3.10	
	929.008	17.64	19.30	4.63	--	41.57	46.00	4.43	
	1082.000	48.56	24.01	4.98	38.02	39.53	74.00	34.47	PK
	1204.000	46.21	24.55	5.15	37.73	38.18	74.00	35.82	
	1373.000	45.90	25.25	5.55	37.28	39.42	74.00	34.58	
	1443.000	45.78	25.46	5.61	37.05	39.80	74.00	34.20	
	1530.000	46.04	25.92	5.64	36.83	40.77	74.00	33.23	
	1786.000	46.47	28.99	6.15	36.37	45.24	74.00	28.76	
	1082.000	35.63	24.01	4.98	38.02	26.60	54.00	27.40	AV
	1204.000	33.26	24.55	5.15	37.73	25.23	54.00	28.77	
	1373.000	31.29	25.25	5.55	37.28	24.81	54.00	29.19	
	1443.000	32.78	25.46	5.61	37.05	26.80	54.00	27.20	
	1530.000	32.02	25.92	5.64	36.83	26.75	54.00	27.25	
	1786.000	33.22	28.99	6.15	36.37	31.99	54.00	22.01	

TEST ENGINEER: NEAL WANG

EUT : LED LCD TV Temperature : 22

Model No. : 50H4 Humidity : 60%RH

Test Mode : HDMI 1920*1080@60Hz Date of Test : Jun 29, 2014

Polarization	Frequency (MHz)	Meter Reading dB (μV)	Antenna Factor (dB/m)	Cable Loss (dB)	Preamp Factor (dB)	Emission Level dB (μV/m)	Limits dB (μV/m)	Margin (dB)	Remark
Vertical	39.024	21.53	13.02	0.76	--	35.31	40.00	4.69	QP
	140.835	24.45	10.30	1.60	--	36.35	43.50	7.15	
	197.200	29.44	8.20	1.94	--	39.58	43.50	3.92	
	292.058	27.22	12.75	2.49	--	42.46	46.00	3.54	
	556.774	20.00	19.10	3.10	--	42.20	46.00	3.80	
	742.259	19.24	18.87	3.57	--	41.68	46.00	4.32	
	1017.000	47.52	23.76	4.91	38.16	38.03	74.00	35.97	PK
	1211.000	45.80	24.58	5.15	37.71	37.82	74.00	36.18	
	1355.000	45.29	25.19	5.51	37.33	38.66	74.00	35.34	
	1429.000	46.32	25.42	5.60	37.09	40.25	74.00	33.75	
	1498.000	46.07	25.60	5.64	36.91	40.40	74.00	33.60	
	1712.000	53.10	28.04	6.01	36.48	50.67	74.00	23.33	AV
	1017.000	34.28	23.76	4.91	38.16	24.79	54.00	29.21	
	1211.000	32.90	24.58	5.15	37.71	24.92	54.00	29.08	
	1355.000	31.93	25.19	5.51	37.33	25.30	54.00	28.70	
	1429.000	33.66	25.42	5.60	37.09	27.59	54.00	26.41	
1498.000	32.51	25.60	5.64	36.91	26.84	54.00	27.16		
1712.000	42.39	28.04	6.01	36.48	39.96	54.00	14.04		

TEST ENGINEER: NEAL WANG

EUT : LED LCD TV Temperature : 22

Model No. : 50H4 Humidity : 60%RH

Test Mode : HDMI 1280*1024@60Hz Date of Test : Jun 29, 2014

Polarization	Frequency (MHz)	Meter Reading dB (μ V)	Antenna Factor (dB/m)	Cable Loss (dB)	Emission Level dB (μ V/m)	Limits dB (μ V/m)	Margin (dB)
Horizontal	74.919	24.50	6.50	1.00	32.00	40.00	8.00
	141.826	24.12	10.30	1.60	36.02	43.50	7.48
	216.783	27.59	7.83	2.03	37.45	46.00	8.55
	307.831	25.04	13.10	2.56	40.70	46.00	5.30
	539.478	18.70	19.50	3.06	41.26	46.00	4.74
	810.265	18.09	20.20	3.70	41.99	46.00	4.01
Vertical	32.979	13.76	16.27	0.70	30.73	40.00	9.27
	66.034	26.85	4.94	0.91	32.70	40.00	7.30
	130.837	23.69	11.72	1.55	36.96	43.50	6.54
	199.286	28.26	8.20	1.95	38.41	43.50	5.09
	539.478	19.32	19.50	3.06	41.88	46.00	4.12
	810.265	17.82	20.20	3.70	41.72	46.00	4.28

TEST ENGINEER: NEAL WANG

EUT : LED LCD TV Temperature : 22

Model No. : 50H4 Humidity : 60%RH

Test Mode : HDMI 640*480@60Hz Date of Test : Jun 29, 2014

Polarization	Frequency (MHz)	Meter Reading dB (μ V)	Antenna Factor (dB/m)	Cable Loss (dB)	Emission Level dB (μ V/m)	Limits dB (μ V/m)	Margin (dB)
Horizontal	73.103	24.98	6.24	0.97	32.19	40.00	7.81
	141.826	24.99	10.30	1.60	36.89	43.50	6.61
	216.024	28.32	7.72	2.03	38.07	46.00	7.93
	306.754	25.82	13.10	2.56	41.48	46.00	4.52
	665.804	14.58	19.30	3.44	37.32	46.00	8.68
	872.183	15.45	20.30	4.20	39.95	46.00	6.05
Vertical	32.979	16.06	16.27	0.70	33.03	40.00	6.97
	64.887	27.21	4.70	0.90	32.81	40.00	7.19
	129.923	23.14	11.90	1.53	36.57	43.50	6.93
	195.822	28.79	8.20	1.92	38.91	43.50	4.59
	373.311	22.02	14.90	2.66	39.58	46.00	6.42
	616.372	17.41	18.78	3.25	39.44	46.00	6.56

TEST ENGINEER: NEAL WANG

EUT : LED LCD TV Temperature : 22

Model No. : 50H4 Humidity : 60%RH

Test Mode : USB Play Date of Test : Jun 29, 2014

Polarization	Frequency (MHz)	Meter Reading dB (μ V)	Antenna Factor (dB/m)	Cable Loss (dB)	Emission Level dB (μ V/m)	Limits dB (μ V/m)	Margin (dB)
Horizontal	135.982	20.65	10.83	1.57	33.05	43.50	10.45
	291.036	19.98	12.83	2.49	35.30	46.00	10.70
	314.283	19.29	13.52	2.57	35.38	46.00	10.62
	432.546	18.34	17.55	2.78	38.67	46.00	7.33
	539.478	13.31	19.50	3.06	35.87	46.00	10.13
	647.386	13.49	18.43	3.38	35.30	46.00	10.70
Vertical	37.945	16.62	14.00	0.75	31.37	40.00	8.63
	52.945	24.35	6.62	0.86	31.83	40.00	8.17
	130.837	20.06	11.72	1.55	33.33	43.50	10.17
	432.546	15.29	17.55	2.78	35.62	46.00	10.38
	539.478	12.93	19.50	3.06	35.49	46.00	10.51
	647.386	15.74	18.43	3.38	37.55	46.00	8.45

TEST ENGINEER: NEAL WANG

5 DEVIATION TO TEST SPECIFICATIONS

None.