

Application for FCC Certificate
On Behalf of
Hisense Electric Co., Ltd.

LED LCD TV

Model No.	Brand
48K25DW, 48H4	Hisense

FCC ID : W9HLCDE0016

Prepared For : Hisense Electric Co., Ltd.
No.218 Qianwangang Road, Economy & Technology
Development Zone, Qingdao, China

Prepared By : Audix Technology (Shanghai) Co., Ltd.
3F and 4F, 34Bldg 680 Guiping Rd,
Caohejing Hi-Tech Park,
Shanghai 200233, China

Tel: +86-21-64955500

Fax: +86-21-64955491

Report No. : ACI-F14104
Date of Test : Jun 16, 2014
Date of Report : Jun 27, 2014

TABLE OF CONTENTS

	Page
1 SUMMARY OF STANDARDS AND RESULTS.....	4
1.1 Description of Standards and Results.....	4
2 GENERAL INFORMATION.....	5
2.1 Description of Equipment Under Test.....	5
2.2 Peripherals.....	6
2.3 Description of Test Facility.....	8
2.4 Measurement Uncertainty.....	8
3 CONDUCTED EMISSION TEST.....	9
3.1 Test Equipment.....	9
3.2 Block Diagram of Test Setup.....	9
3.3 Conducted Emission Limit [FCC Part 15 Subpart B 15.107(a)].....	10
3.4 Test Configuration.....	10
3.5 Operating Condition of EUT.....	11
3.6 Test Procedures.....	11
3.7 Test Results.....	12
4 RADIATED EMISSION TEST.....	17
4.1 Test Equipment.....	17
4.2 Block Diagram of Test Setup.....	17
4.3 Radiated Emission Limit [FCC Part 15 Subpart B 15.109(a)].....	18
4.4 Test Configuration.....	18
4.5 Operating Condition of EUT.....	18
4.6 Test Procedures.....	19
4.7 Test Results.....	19
5 DEVIATION TO TEST SPECIFICATIONS.....	26

TEST REPORT FOR FCC CERTIFICATE

Applicant : Hisense Electric Co., Ltd.
 Manufacturer : Hisense Electric Co., Ltd.
 Factory #1 : Hisense Electric Co., Ltd.
 Factory #2 : Tatung Mexico S.A. de C.V.
 EUT Description : LED LCD TV

Model No.	Brand	Power Supply
48K25DW, 48H4	Hisense	120V/60Hz

Test Procedure Used:

*FCC RULES AND REGULATIONS PART 15 SUBPART B CLASS B OCTOBER 2013
AND ANSI C63.4-2003*

The device described above is tested by Audix Technology (Shanghai) Co., Ltd. to determine the maximum emission levels emanating from the device. The maximum emission levels are compared to the FCC Part 15 Subpart B (Class B) limits both radiated and conducted emissions.

The test results are contained in this test report and Audix Technology (Shanghai) Co., Ltd. is assumed full responsibility for the accuracy and completeness of these measurements. This report shows that the EUT (M/N: Refer to Sec.2.1) which was tested in 3m anechoic chamber Jun 16, 2014 is technically compliance with the FCC official limits also.

This report applies to above tested sample only. This report shall not be reproduced in part without written approval of Audix Technology (Shanghai) Co., Ltd.

This report contains data that are not covered by the NVLAP accreditation.

This report must not be used by the client to claim product certification, approval, or endorsement by NVLAP, NIST, or any agency of the federal government.

The test results for EUT's TV functions are contained in No.F14103, a Verification report.

Date of Test : Jun 16, 2014 Date of Report : Jun 27, 2014

Producer : 
 EMILY ZHU / Assistant

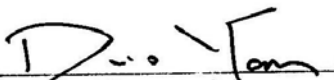
Review : 
 DIAO YANG / Deputy Manager

 For and on behalf of
 Audix Technology (Shanghai) Co., Ltd.

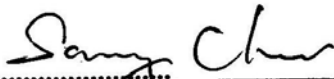
Signatory : 
 Authorized Signature EMC SAMMY CHEN / Deputy Manager

1 SUMMARY OF STANDARDS AND RESULTS

1.1 Description of Standards and Results

The EUT have been tested according to the applicable standards as referenced below:

Description of Test Item	Standard	Limits	Results
EMISSION			
Conducted Disturbance at the Mains Terminal	FCC RULES AND REGULATIONS PART 15 SUBPART B OCTOBER 2013 AND ANSI C63.4-2003	15.107(a) Class B	Pass
Radiated Disturbance	FCC RULES AND REGULATIONS PART 15 SUBPART B OCTOBER 2013 AND ANSI C63.4-2003	15.109(a) Class B	Pass

2 GENERAL INFORMATION

2.1 Description of Equipment Under Test

Description	:	LED LCD TV
Type of EUT	:	<input checked="" type="checkbox"/> Production <input type="checkbox"/> Pre-product <input type="checkbox"/> Pro-type
Model No.	:	48K25DW; 48H4
Note	:	The above models are all the same except for model name. 48H4 model is tested and recorded in the report.
Brand Name	:	Hisense
Applicant	:	Hisense Electric Co., Ltd. No.218 Qianwangang Road, Economy & Technology Development Zone, Qingdao, China
Manufacturer	:	Hisense Electric Co., Ltd. No.218 Qianwangang Road, Economy & Technology Development Zone, Qingdao, China
Factory #1	:	Hisense Electric Co., Ltd. No.218 Qianwangang Road, Economy & Technology Development Zone, Qingdao, China
Factory #2	:	Tatung Mexico S.A. de C.V. Miguel Catalán 420, Parque Industrial Rio Bravo, Cd. Juarez, Chih., CP 32557
LCD Panel	:	Manufacturer : Hisense M/N : HD480DF-B37\S0.B2
Max Resolution	:	1920*1080@60Hz
HDMI Cable	:	Shielded, Detachable, 1.00m
Power Cord	:	Unshielded, Detachable, 1.80m

Remark:

The EUT is a LED LCD TV which input/output ports as follows:

Side Port:

- (1) One HDMI1 (ARC) Port : Connected with PC
- (2) One Ant/Cable Port : Connected with Antenna or ATSC SG / TV SG
- (3) One Earphone/AUDIO OUT Port : Connected with Earphone
- (4) One DIGITAL AUDIO OUT Port : Connected with DVD PLAYER #2
- (5) One component of AV IN Port : Connected with DVD PLAYER#1

Bottom Port:

- (6) One USB Port : Connected with U-Disk
- (7) One HDMI3 Port : Connected with DVD PLAYER#1
- (8) One HDMI2 Port : Connected with DVD PLAYER#2

2.2 Peripherals

2.2.1 PC

Manufacturer : HP
Model Number : dx7200MT
Serial Number : CNG622017W
Power Cord : Unshielded, Detachable, 1.8m
Certificate : FCC DoC; CE/EMC; VCCI; C-Tick; BSMI, 3C, MIC

2.2.2 Printer

Manufacturer : HP
Model Number : C3990A
Serial Number : JPZX020487
Data Cable : Shielded, detachable, 1.5m
Certificate : GS, CE/EMC, C-Tick, FCC DoC

2.2.3 Keyboard

Manufacturer : Microsoft
Model Number : RT2300
Serial Number : 7668200662248
Data Cable : Shielded, Undetachable ,1.8m
Certificate : CE/EMC, FCC DoC, VCCI, MIC, C-Tick, BSMI

2.2.4 Mouse

Manufacturer : Microsoft
Model Number : RT2300
Serial Number : 6965712071551
Data Cable : Shielded, Undetachable, 1.8m.
Certificate : CE/EMC, FCC DoC, VCCI, MIC, C-Tick,
BSMI

2.2.5 Modem

Manufacturer : TP-LINK
Model Number : TM-EC5658V
Serial Number : 07123301053
Data Cable : Shielded, Detachable, 1.8m
Certificate : FCC DoC, CE/EMC, CCC

2.2.6 TV Signal Generator

Manufacturer : FLUKE
Model Number : 54200m01
Serial Number : 814008
Data Cable : Shielded, detachable, 2.0m
Power Cord : Unshielded, detachable, 2.0m
Certificate : CE/EMC, FCC DoC, CCC

2.2.7 ATSC Signal Generator

Manufacturer : SENCORE
Model Number : ATSC997
Serial Number : 6790071

2.2.8 DVD PLAYER#1

Manufacturer : PHILIPS
Model Number : DVP3986K/93
Serial Number : KX1A0902120108
Certificate : FCC DoC, CE/EMC, CCC

2.2.9 DVD PLAYER#2

Manufacturer : PHILIPS
Model Number : DVP3986K/93
Serial Number : KX1A0902120082
Certificate : FCC DoC, CE/EMC, CCC

2.2.10 Earphone

Manufacturer : Skullcandy
Model Number : FMJ

2.2.11 U-DISK

Manufacturer : LG
Model Number : 1GB

2.3 Description of Test Facility

Site Description (No.3 3m Chamber)	:	Sept. 17, 1998 file on Mar 16, 2012 Renewed Federal Communications Commission FCC Engineering Laboratory 7435 Oakland Mills Road Columbia, MD 21046, USA
Name of Firm	:	Audix Technology (Shanghai) Co., Ltd.
Site Location	:	3F 34Bldg 680 Guiping Rd, Caohejing Hi-Tech Park, Shanghai 200233, China
NVLAP Lab Code	:	200371-0

2.4 Measurement Uncertainty

Conducted Emission Expanded Uncertainty:	U = 3.02 dB
Radiated Emission Expanded Uncertainty (30-200MHz):	U = 4.17 dB (Horizontal) U = 4.02 dB (Vertical)
Radiated Emission Expanded Uncertainty (200M-1GHz):	U = 3.38 dB (Horizontal) U = 3.28 dB (Vertical)
Radiated Emission Expanded Uncertainty (Above 1GHz):	U = 4.68 dB (Horizontal) U = 4.87 dB (Vertical)

3 CONDUCTED EMISSION TEST

3.1 Test Equipment

The following test equipments are used during the conducted emission test in a shielded room:

Item	Type	Manufacturer	Model No.	Serial No.	Last Cal.	Next Cal.
1.	Test Receiver	R&S	ESCI	100841	Mar 20, 2014	Mar 19, 2015
2.	Artificial Mains Network (AMN)	R&S	ESH2-Z5	843890/011	Feb 25, 2014	Feb 24, 2015
3.	Line Impedance Stabilization Network (LISN)	Kyoritsu	KNW-407	8-1280-4	Mar 20, 2014	Mar 19, 2015
4.	50Ω Coaxial Switch	Anritsu	MP59B	6200426389	Mar 18, 2014	Sep 17, 2015
5.	50Ω Terminator	Anritsu	BNC	001	Mar 20, 2014	Mar 19, 2015
6.	Software	Audix	E3	6.2009-1-15	--	--

3.2 Block Diagram of Test Setup

3.2.1 EUT & Peripherals

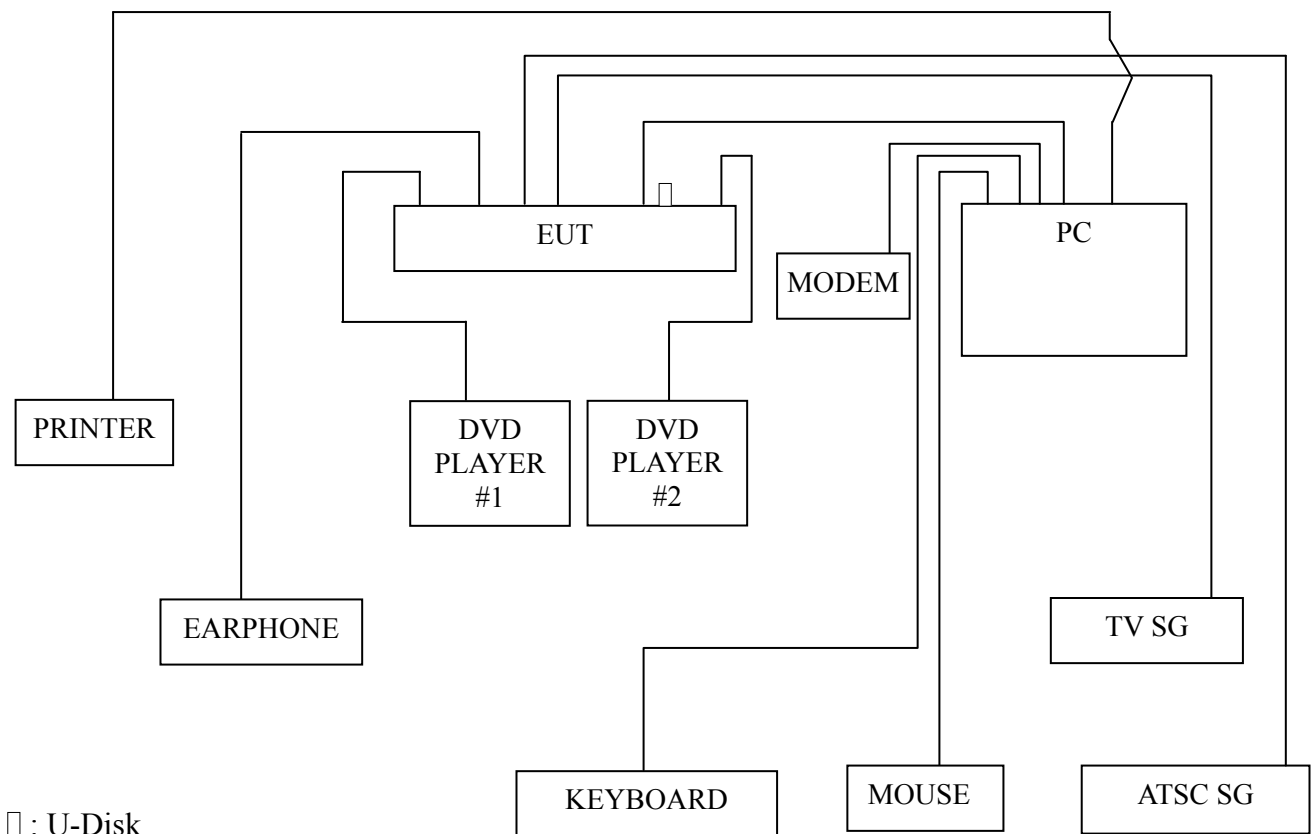

3.2.2 Conducted Disturbance Test Setup

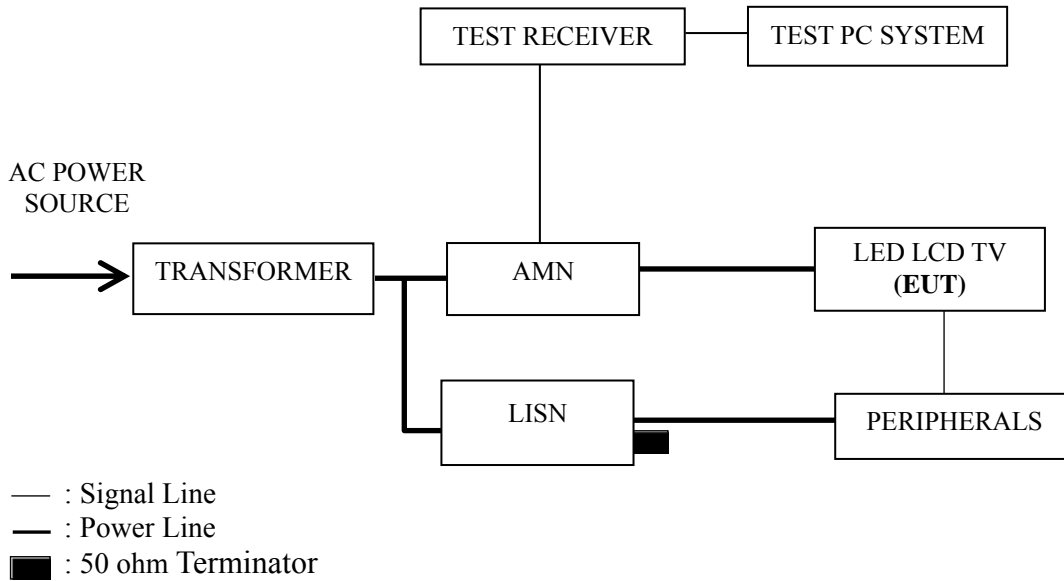

3.3 Conducted Emission Limit [FCC Part 15 Subpart B 15.107(a)]

Frequency Range (MHz)	Limits dB (μ V)	
	Quasi-peak	Average
0.15 ~ 0.5	66~56	56~46
0.5 ~ 5	56	46
5 ~ 30	60	50

NOTE 1 – The lower limit shall apply at the transition frequencies.
 NOTE 2 – The limit decreases linearly with the logarithm of the frequency in the range 0.15 MHz~0.50 MHz

3.4 Test Configuration

The EUT (listed in Sec.2.1) and the peripherals (listed in Sec 2.2) were installed as shown on Sec.3.2 to meet FCC requirement and operating in a manner that tends to maximize its emission level in a normal application.

3.5 Operating Condition of EUT

- 3.5.1 Setup the EUT and peripherals as shown in Sec. 3.2.
- 3.5.2 Turn on the power of all equipments and the EUT.
- 3.5.3 Set the contrast & brightness of EUT to maximum.
- 3.5.4 PC system ran the self-test program “EMC Test” by windows XP and sent “H” characters to EUT through graphic card, the EUT’s screen displayed and filled with “H” pattern by its resolution (Via HDMI Input).
- 3.5.5 In USB Play mode, set the EUT play digital media from U-Disk.
- 3.5.6 The WLAN function is operating to communicate with WLAN router.
- 3.5.7 The other peripherals devices were driven and operated during the test.
- 3.5.8 The test modes are as follows:

Test Mode
HDMI 1920*1080@60Hz
HDMI 1280*1024@60Hz
HDMI 640*480@60Hz
USB Play

3.6 Test Procedures

The EUT and peripherals were connected to the power mains through an Artificial Mains Network (AMN). This provided a 50 ohm coupling impedance for the measuring equipment.

Both sides of AC line (Line & Neutral) were checked for maximum conducted interference. In order to find the maximum emission, the relative positions of equipment and all of the interface cables were changed or manipulated according to ANSI C63.4:2003 during conducted emission test.

The bandwidth of R&S Test Receiver ESCI was set at 9 kHz.

The frequency range from 150 kHz to 30 MHz was checked.

The test modes were done on conducted disturbance test and all the test results are listed in Sec. 3.7.

3.7 Test Results

< **PASS** >

The frequency and amplitude of the highest conducted emission relative to the limit is reported. All emissions not reported below are too low against the prescribed limits.

Test Mode	Data Page
HDMI 1920*1080@60Hz	P13
HDMI 1280*1024@60Hz	P14
HDMI 640*480@60Hz	P15
USB Play	P16

NOTE 1 – Factor = Cable Loss + AMN Factor.

NOTE 2 – Emission Level = Meter Reading + Factor.

NOTE 3 – “QP” means “Quasi-Peak” values, “AV” means “Average” values.

NOTE 4 – The worst case is for HDMI 1280*1024@60Hz test mode. The worst emission is detected at 0.172 MHz (Quasi-Peak Value) with corrected signal level of 58.74 dB (μ V) (limit is 64.87 dB (μ V)), when the Line of the EUT is connected to AMN.

EUT : LED LCD TV Temperature : 22°C
 Model No. : 48H4 Humidity : 48%RH
 Test Mode : HDMI 1920*1080@60Hz Date of Test : Jun 16, 2014

Test Line	Frequency (MHz)	Meter Reading dB(μ V)	Factor (dB)	Emission Level dB(μ V)	Limits dB(μ V)	Margin (dB)	Remark
Line	0.172	58.61	0.13	58.74	64.87	6.13	QP
	0.606	38.5	0.04	38.54	56.00	17.46	
	1.207	36.5	0.05	36.55	56.00	19.45	
	2.194	34.3	0.08	34.38	56.00	21.62	
	7.281	53.1	0.26	53.36	60.00	6.64	
	23.580	31.31	-0.37	30.94	60.00	29.06	
	0.172	45.41	0.13	45.54	54.87	9.33	AV
	0.606	28.4	0.04	28.44	46.00	17.56	
	1.207	24.8	0.05	24.85	46.00	21.15	
	2.194	25.5	0.08	25.58	46.00	20.42	
	7.281	37.8	0.26	38.06	50.00	11.94	
	23.580	25.21	-0.37	24.84	50.00	25.16	
Neutral	0.171	58.30	0.17	58.47	64.92	6.45	QP
	0.406	40.29	0.22	40.51	57.74	17.23	
	1.205	36.30	0.17	36.47	56.00	19.53	
	2.035	32.80	0.17	32.97	56.00	23.03	
	7.254	53.00	0.34	53.34	60.00	6.66	
	21.810	30.60	0.84	31.44	60.00	28.56	
	0.171	45.30	0.17	45.47	54.92	9.45	AV
	0.406	29.59	0.22	29.81	47.74	17.93	
	1.205	24.90	0.17	25.07	46.00	20.93	
	2.035	23.00	0.17	23.17	46.00	22.83	
	7.254	37.00	0.34	37.34	50.00	12.66	
	21.810	25.20	0.84	26.04	50.00	23.96	

TEST ENGINEER: ERIC TANG

EUT : LED LCD TV Temperature : 22°C
 Model No. : 48H4 Humidity : 48%RH
 Test Mode : HDMI 1280*1024@60Hz Date of Test : Jun 16, 2014

Test Line	Frequency (MHz)	Meter Reading dB(μ V)	Factor (dB)	Emission Level dB(μ V)	Limits dB(μ V)	Margin (dB)	Remark
Line	0.173	57.21	0.13	57.34	64.81	7.47	QP
	0.610	39.80	0.04	39.84	56.00	16.16	
	1.371	35.90	0.06	35.96	56.00	20.04	
	2.234	33.90	0.08	33.98	56.00	22.02	
	7.353	53.20	0.26	53.46	60.00	6.54	
	23.600	31.81	-0.37	31.44	60.00	28.56	
	0.173	45.31	0.13	45.44	54.81	9.37	AV
	0.610	27.50	0.04	27.54	46.00	18.46	
	1.371	25.50	0.06	25.56	46.00	20.44	
	2.234	25.00	0.08	25.08	46.00	20.92	
	7.353	38.50	0.26	38.76	50.00	11.24	
	23.600	24.91	-0.37	24.54	50.00	25.46	
Neutral	0.170	58.10	0.17	58.27	64.95	6.68	QP
	0.403	40.09	0.22	40.31	57.80	17.49	
	0.611	40.30	0.15	40.45	56.00	15.55	
	1.392	36.50	0.17	36.67	56.00	19.33	
	7.265	52.80	0.34	53.14	60.00	6.86	
	21.710	30.70	0.84	31.54	60.00	28.46	
	0.170	45.00	0.17	45.17	54.95	9.78	AV
	0.403	29.89	0.22	30.11	47.80	17.69	
	0.611	27.50	0.15	27.65	46.00	18.35	
	1.392	26.70	0.17	26.87	46.00	19.13	
	7.265	38.30	0.34	38.64	50.00	11.36	
	21.710	25.20	0.84	26.04	50.00	23.96	

TEST ENGINEER: ERIC TANG

EUT : LED LCD TV Temperature : 22°C
 Model No. : 48H4 Humidity : 48%RH
 Test Mode : HDMI 640*480@60Hz Date of Test : Jun 16, 2014

Test Line	Frequency (MHz)	Meter Reading dB(μV)	Factor (dB)	Emission Level dB(μV)	Limits dB(μV)	Margin (dB)	Remark
Line	0.169	58.20	0.14	58.34	65.02	6.68	QP
	0.739	36.80	0.10	36.90	56.00	19.10	
	1.206	36.30	0.05	36.35	56.00	19.65	
	2.379	33.90	0.09	33.99	56.00	22.01	
	7.328	52.30	0.26	52.56	60.00	7.44	
	20.240	31.30	-0.07	31.23	60.00	28.77	
	0.169	44.90	0.14	45.04	55.02	9.98	AV
	0.739	21.00	0.10	21.10	46.00	24.90	
	1.206	25.80	0.05	25.85	46.00	20.15	
	2.379	24.80	0.09	24.89	46.00	21.11	
	7.328	37.70	0.26	37.96	50.00	12.04	
	20.240	25.80	-0.07	25.73	50.00	24.27	
Neutral	0.172	57.80	0.17	57.97	64.89	6.92	QP
	0.610	40.30	0.15	40.45	56.00	15.55	
	1.403	37.50	0.17	37.67	56.00	18.33	
	2.367	34.00	0.16	34.16	56.00	21.84	
	7.329	52.51	0.34	52.85	60.00	7.15	
	21.680	30.90	0.84	31.74	60.00	28.26	
	0.172	45.50	0.17	45.67	54.89	9.22	AV
	0.610	28.20	0.15	28.35	46.00	17.65	
	1.403	27.30	0.17	27.47	46.00	18.53	
	2.367	25.00	0.16	25.16	46.00	20.84	
	7.329	38.51	0.34	38.85	50.00	11.15	
	21.680	25.80	0.84	26.64	50.00	23.36	

TEST ENGINEER: ERIC TANG

EUT : LED LCD TV Temperature : 22°C
 Model No. : 48H4 Humidity : 48%RH
 Test Mode : USB Play Date of Test : Jun 16, 2014

Test Line	Frequency (MHz)	Meter Reading dB(μ V)	Factor (dB)	Emission Level dB(μ V)	Limits dB(μ V)	Margin (dB)	Remark
Line	0.169	58.50	0.14	58.64	64.99	6.35	QP
	0.611	39.80	0.04	39.84	56.00	16.16	
	1.183	36.49	0.06	36.55	56.00	19.45	
	2.259	34.20	0.09	34.29	56.00	21.71	
	7.376	52.50	0.26	52.76	60.00	7.24	
	20.030	31.20	-0.05	31.15	60.00	28.85	
	0.169	44.60	0.14	44.74	54.99	10.25	AV
	0.611	27.30	0.04	27.34	46.00	18.66	
	1.183	25.09	0.06	25.15	46.00	20.85	
	2.259	25.20	0.09	25.29	46.00	20.71	
	7.376	38.30	0.26	38.56	50.00	11.44	
	20.030	25.80	-0.05	25.75	50.00	24.25	
Neutral	0.169	58.00	0.17	58.17	65.01	6.84	QP
	0.607	40.30	0.16	40.46	56.00	15.54	
	1.344	35.51	0.16	35.67	56.00	20.33	
	2.251	34.10	0.17	34.27	56.00	21.73	
	7.318	51.91	0.34	52.25	60.00	7.75	
	20.830	30.40	0.82	31.22	60.00	28.78	
	0.169	45.00	0.17	45.17	55.01	9.84	AV
	0.607	29.20	0.16	29.36	46.00	16.64	
	1.344	25.71	0.16	25.87	46.00	20.13	
	2.251	25.30	0.17	25.47	46.00	20.53	
	7.318	37.61	0.34	37.95	50.00	12.05	
	20.830	25.40	0.82	26.22	50.00	23.78	

TEST ENGINEER: ERIC TANG

4 RADIATED EMISSION TEST

4.1 Test Equipment

The following test equipments are used during the radiated emission test in a semi-anechoic chamber:

Item	Type	Manufacturer	Model No.	Serial No.	Last Cal.	Next Cal.
1.	Test Receiver	R&S	ESCI	101302	Sep 03, 2013	Sep 02, 2014
2.	Preamplifier	Agilent	8447D	2944A10548	Mar 18, 2014	Sep 17, 2014
3.	Preamplifier	HP	8449B	3008A00864	Mar 20, 2014	Mar 19, 2015
4.	Bi-log Antenna	TESEQ	CBL6112D	23193	May 03, 2014	May 02, 2015
5.	Horn Antenna	EMCO	3115	9607-4878	May 11, 2014	May 10, 2015
6.	Spectrum	Agilent	E7405A	MY45106600	Nov 11, 2013	Nov 10, 2014
7.	50 Ω Coaxial Switch	Anritsu	MP59B	6200426390	Mar 18, 2014	Sep 17, 2014
8.	Software	Audix	E3	6.2007-9-10	--	--

4.2 Block Diagram of Test Setup

4.2.1 EUT & Peripherals

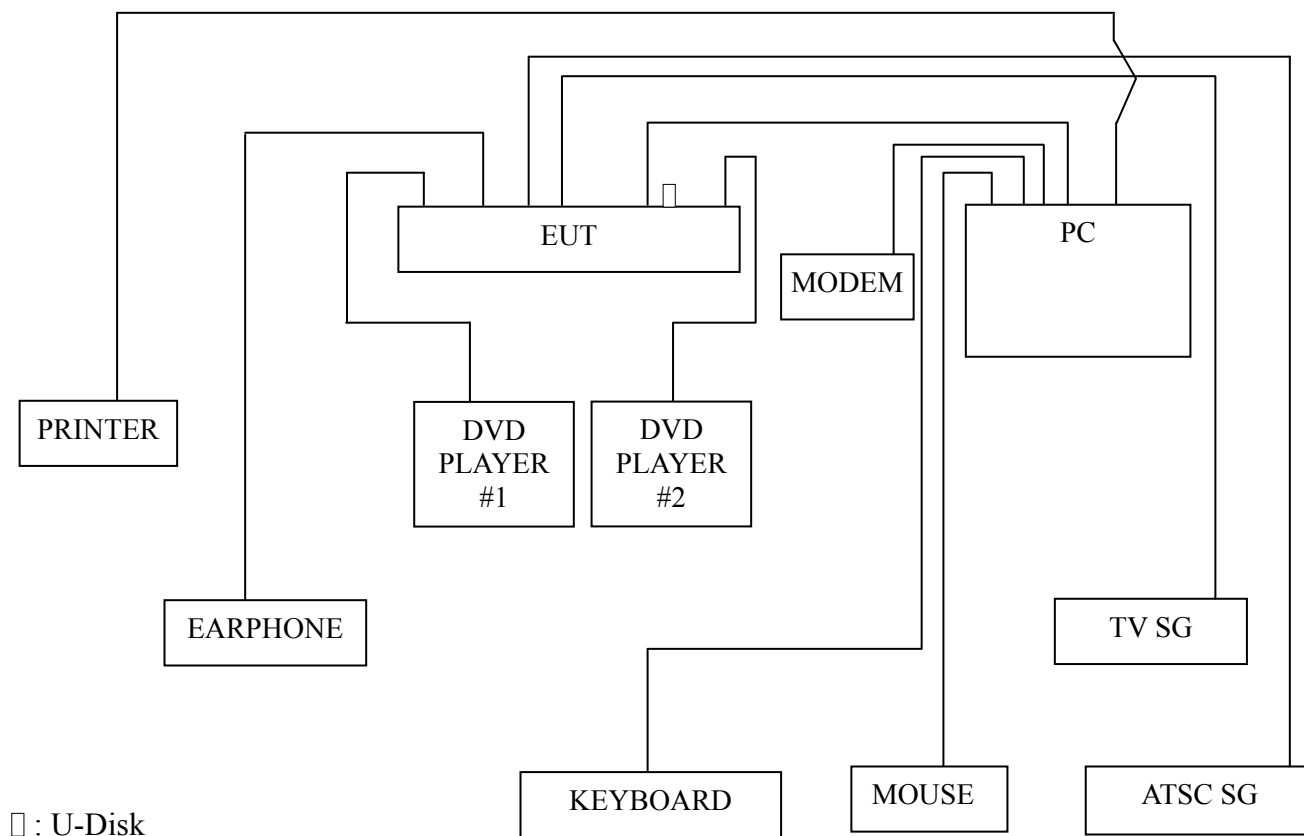

4.2.2 Radiated emission test setup

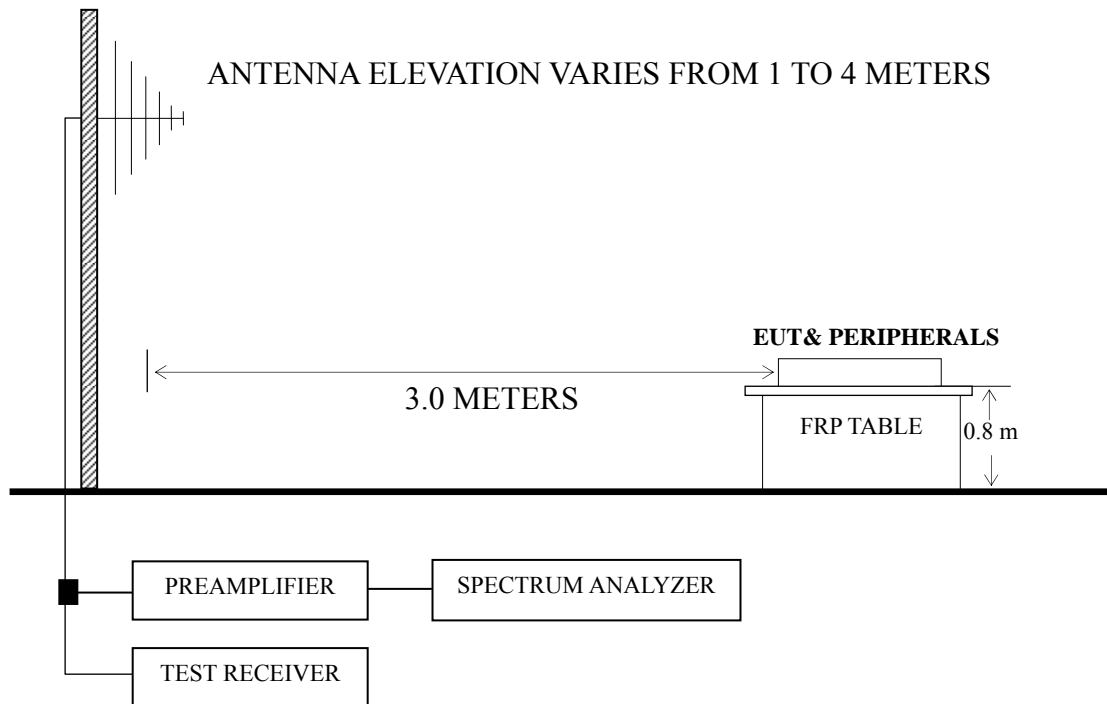

■ : 50 ohm Coaxial Switch

4.3 Radiated Emission Limit [FCC Part 15 Subpart B 15.109(a)]

Frequency (MHz)	Distance (m)	Field strength limits	
		($\mu\text{V/m}$)	dB ($\mu\text{V/m}$)
30 ~ 88	3	100	40.0
88 ~ 216	3	150	43.5
216 ~ 960	3	200	46.0
Above 960	3	500	54.0

NOTE 1 - Emission Level dB ($\mu\text{V/m}$) = 20 log Emission Level ($\mu\text{V/m}$)

NOTE 2 - The tighter limit applies at the band edges.

NOTE 3 - Distance refers to the distance in meters between the measuring instrument antenna and the closed point of any part of the device or system.

NOTE 4 - The limits shown are based on Quasi-peak value detector.

NOTE 5 - Above 1 GHz, the limit on peak emission is 20 dB above the maximum permitted average emission limit applicable to the EUT.

4.4 Test Configuration

The configuration of the EUT and peripherals are same as those used in conducted emission test.

Please refer to Sec.3.4.

4.5 Operating Condition of EUT

Same as conducted emission test which is listed in Sec.3.5, except for the test setup replaced by Sec.4.2.

4.6 Test Procedures

The EUT and peripherals were placed on a FRP turntable that is 0.8 meter above ground. The FRP turntable rotated 360 degrees to determine the position of the maximum emission level. The EUT was set 3 meters away from the receiving antenna, which was mounted on an antenna tower. Broadband antenna (Calibrated Bilog Antenna) was used as receiving antenna. The antenna moved up and down between 1 meter and 4 meters to find out the maximum emission level. Both horizontal and vertical polarizations of the antenna were set on measurement. In order to find the maximum emission, all of the interference cables were manipulated according to ANSI C63.4:2003 requirements during radiated emission test.

The I.F. bandwidth of Test Receiver R&S ESCI was set at 120 kHz.

The frequency range from 30 MHz to 1000MHz was checked for all test modes.

The frequency range from 1 GHz to 24 GHz (10th harmonic of the 2.4GHz RF function) was checked for worst test mode in 30 – 1000 MHz test.

The test modes were done on radiated disturbance test and all the test results are listed in Sec.4.7.

4.7 Test Results

<PASS>

The frequency and amplitude of the highest radiated emission relative the limit is reported. All the emissions not reported below are too low against the FCC limit.

Test Mode	Data Page
HDMI 1920*1080@60Hz	P21
HDMI 1280*1024@60Hz	P22 – P23
HDMI 640*480@60Hz	P24
USB Play	P25

NOTE 1 – Emission Level = Antenna Factor + Cable Loss + Meter Reading. (< 1GHz);

Emission Level = Antenna Factor + Cable Loss – Preamp Factor + Meter Reading. (> 1GHz)

NOTE 2 – All readings are Quasi-Peak values below or equal to 1GHz, Peak and Average values above 1GHz.

NOTE 3 – 0° was the table front facing the antenna. Degree is calculated from 0° clockwise facing the antenna.

NOTE 4 – The worst case is for HDMI 1280*1024@60Hz test mode. The worst emission at horizontal polarization was detected at 74.919 MHz with corrected signal level of 33.38 dB ($\mu\text{V}/\text{m}$) (limit is 40.00 dB ($\mu\text{V}/\text{m}$)), when the antenna was 1.20 m height and the turntable was at 225°. The worst emission at vertical polarization was detected at 30.600 MHz with corrected signal level of 37.92 dB ($\mu\text{V}/\text{m}$) (limit is 40.00 dB ($\mu\text{V}/\text{m}$)), when the antenna was 1.20 m height and the turntable was at 300°.

EUT : LED LCD TV Temperature : 22°C

Model No. : 48H4 Humidity : 60%RH

Test Mode : HDMI 1920*1080@60Hz Date of Test : Jun 16, 2014

Polarization	Frequency (MHz)	Meter Reading dB (μ V)	Antenna Factor (dB/m)	Cable Loss (dB)	Emission Level dB (μ V/m)	Limits dB (μ V/m)	Margin (dB)
Horizontal	75.446	25.87	6.54	1.01	33.42	40.00	6.58
	136.939	21.86	10.65	1.58	34.09	43.50	9.41
	233.349	18.79	9.85	2.11	30.75	46.00	15.25
	404.667	15.02	16.25	2.69	33.96	46.00	12.04
	739.661	17.67	18.90	3.57	40.14	46.00	5.86
	929.008	15.16	19.30	4.63	39.09	46.00	6.91
Vertical	30.962	18.47	17.65	0.67	36.79	40.00	3.21
	35.005	20.09	15.81	0.72	36.62	40.00	3.38
	77.865	22.87	6.67	1.05	30.59	40.00	9.41
	135.982	21.73	10.83	1.57	34.13	43.50	9.37
	742.259	16.66	18.87	3.57	39.10	46.00	6.90
	891.050	17.89	19.80	4.43	42.12	46.00	3.88

TEST ENGINEER: NEAL WANG

EUT : LED LCD TV Temperature : 22°C
 Model No. : 48H4 Humidity : 60%RH
 Test Mode : HDMI 1280*1024@60Hz Date of Test : Jun 16, 2014

Polarization	Frequency (MHz)	Meter Reading dB (μV)	Antenna Factor (dB/m)	Cable Loss (dB)	Preamp Factor (dB)	Emission Level dB (μV/m)	Limits dB (μV/m)	Margin (dB)	Remark
Horizontal	74.919	25.88	6.50	1.00	--	33.38	40.00	6.62	QP
	135.032	21.28	11.00	1.57	--	33.85	43.50	9.65	
	223.733	21.55	8.43	2.08	--	32.06	46.00	13.94	
	400.432	15.81	16.20	2.69	--	34.70	46.00	11.30	
	670.489	14.98	19.60	3.44	--	38.02	46.00	7.98	
	945.440	12.32	19.50	4.68	--	36.50	46.00	9.50	
	1065.000	47.83	23.95	4.96	38.06	38.68	74.00	35.32	PK
	1349.000	46.01	25.17	5.47	37.34	39.31	74.00	34.69	
	1454.000	46.28	25.49	5.62	37.03	40.36	74.00	33.64	
	1557.000	48.74	26.20	5.65	36.77	43.82	74.00	30.18	
	1818.000	46.47	29.35	6.16	36.33	45.65	74.00	28.35	
	1965.000	45.51	30.73	6.19	36.14	46.29	74.00	27.71	
	1065.000	32.83	23.95	4.96	38.06	23.68	54.00	30.32	AV
	1349.000	31.21	25.17	5.47	37.34	24.51	54.00	29.49	
	1454.000	33.56	25.49	5.62	37.03	27.64	54.00	26.36	
	1557.000	35.39	26.20	5.65	36.77	30.47	54.00	23.53	
	1818.000	32.46	29.35	6.16	36.33	31.64	54.00	22.36	
	1965.000	32.48	30.73	6.19	36.14	33.26	54.00	20.74	

TEST ENGINEER: NEAL WANG

EUT : LED LCD TV Temperature : 22°C
 Model No. : 48H4 Humidity : 60%RH
 Test Mode : HDMI 1280*1024@60Hz Date of Test : Jun 16, 2014

Polarization	Frequency (MHz)	Meter Reading dB (μV)	Antenna Factor (dB/m)	Cable Loss (dB)	Preamp Factor (dB)	Emission Level dB (μV/m)	Limits dB (μV/m)	Margin (dB)	Remark
Vertical	30.600	19.17	18.09	0.66	--	37.92	40.00	2.08	QP
	129.923	20.96	11.90	1.53	--	34.39	43.50	9.11	
	216.024	21.40	7.72	2.03	--	31.15	46.00	14.85	
	446.414	13.20	17.07	2.82	--	33.09	46.00	12.91	
	675.208	9.94	19.40	3.48	--	32.82	46.00	13.18	
	818.834	10.24	20.53	3.80	--	34.57	46.00	11.43	
	1057.000	47.34	23.91	4.96	38.07	38.14	74.00	35.86	PK
	1117.000	46.10	24.15	5.01	37.94	37.32	74.00	36.68	
	1183.000	45.88	24.45	5.08	37.78	37.63	74.00	36.37	
	1243.000	45.66	24.74	5.25	37.63	38.02	74.00	35.98	
	1631.000	46.69	27.03	5.81	36.62	42.91	74.00	31.09	
	1857.000	45.82	29.73	6.16	36.27	45.44	74.00	28.56	
	1057.000	34.33	23.91	4.96	38.07	25.13	54.00	28.87	AV
	1117.000	33.22	24.15	5.01	37.94	24.44	54.00	29.56	
	1183.000	32.82	24.45	5.08	37.78	24.57	54.00	29.43	
	1243.000	32.43	24.74	5.25	37.63	24.79	54.00	29.21	
	1631.000	31.21	27.03	5.81	36.62	27.43	54.00	26.57	
	1857.000	30.83	29.73	6.16	36.27	30.45	54.00	23.55	

EUT : LED LCD TV Temperature : 22°C

Model No. : 48H4 Humidity : 60%RH

Test Mode : HDMI 640*480@60Hz Date of Test : Jun 16, 2014

Polarization	Frequency (MHz)	Meter Reading dB (μ V)	Antenna Factor (dB/m)	Cable Loss (dB)	Emission Level dB (μ V/m)	Limits dB (μ V/m)	Margin (dB)
Horizontal	75.977	26.41	6.55	1.01	33.97	40.00	6.03
	130.837	21.33	11.72	1.55	34.60	43.50	8.90
	230.099	18.40	9.70	2.11	30.21	46.00	15.79
	404.667	14.92	16.25	2.69	33.86	46.00	12.14
	524.554	11.70	18.33	3.03	33.06	46.00	12.94
	979.180	9.83	21.00	4.78	35.61	54.00	18.39
Vertical	30.780	19.28	17.95	0.67	37.90	40.00	2.10
	73.103	22.06	6.24	0.97	29.27	40.00	10.73
	130.837	20.05	11.72	1.55	33.32	43.50	10.18
	216.024	22.40	7.72	2.03	32.15	46.00	13.85
	446.414	11.92	17.07	2.82	31.81	46.00	14.19
	818.834	7.55	20.53	3.80	31.88	46.00	14.12

TEST ENGINEER: NEAL WANG

EUT : LED LCD TV Temperature : 22°C

Model No. : 48H4 Humidity : 60%RH

Test Mode : USB Play Date of Test : Jun 16, 2014

Polarization	Frequency (MHz)	Meter Reading dB (μ V)	Antenna Factor (dB/m)	Cable Loss (dB)	Emission Level dB (μ V/m)	Limits dB (μ V/m)	Margin (dB)
Horizontal	84.110	19.00	7.27	1.13	27.40	40.00	12.60
	124.569	14.15	11.49	1.50	27.14	43.50	16.36
	191.074	12.72	7.95	1.91	22.58	43.50	20.92
	375.939	10.85	15.00	2.66	28.51	46.00	17.49
	622.890	5.09	18.78	3.28	27.15	46.00	18.85
	948.761	7.40	19.50	4.68	31.58	46.00	14.42
Vertical	32.979	16.14	16.27	0.70	33.11	40.00	6.89
	67.202	15.54	5.19	0.91	21.64	40.00	18.36
	107.888	11.90	11.66	1.39	24.95	43.50	18.55
	180.017	11.70	8.20	1.84	21.74	43.50	21.76
	271.325	12.63	12.60	2.35	27.58	46.00	18.42
	607.787	4.34	18.38	3.22	25.94	46.00	20.06

TEST ENGINEER: NEAL WANG

5 DEVIATION TO TEST SPECIFICATIONS

None.