

Application for FCC Certificate
On Behalf of
Hisense Electric Co., Ltd.

LCD TV

Model No.	Serial No.	Brand
LTDN47T18GUS	E2009101301	Hisense
NX4703L120	--	NEXUS

FCC ID : W9HLCDE0002

Prepared For : Hisense Electric Co., Ltd.
No.218 Qianwangang Road, Economy & Technology
Development Zone, Qingdao, China

Prepared By : Audix Technology (Shanghai) Co., Ltd.
3F 34Bldg 680 Guiping Rd,
Caohejing Hi-Tech Park,
Shanghai 200233, China

Tel: +86-21-64955500
Fax: +86-21-64955491

Report No. : ACI-F09107
Date of Test : Oct 13 - 22, 2009
Date of Report : Nov 05, 2009

TABLE OF CONTENTS

	Page
1 SUMMARY OF STANDARDS AND RESULTS.....	4
1.1 Description of Standards and Results.....	4
2 GENERAL INFORMATION.....	5
2.1 Description of Equipment Under Test.....	5
2.2 Peripherals.....	7
2.3 Description of Test Facility.....	8
2.4 Measurement Uncertainty.....	8
3 CONDUCTED EMISSION TEST.....	9
3.2 Block Diagram of Test Setup.....	9
3.3 Conducted Emission Limit [FCC Part 15 Subpart B 15.107(a)].....	10
3.4 Test Configuration.....	10
3.5 Operating Condition of EUT.....	11
3.6 Test Procedures.....	11
3.7 Test Results.....	12
4 RADIATED EMISSION TEST.....	19
4.1 Test Equipment.....	19
4.2 Block Diagram of Test Setup.....	19
4.3 Radiated Emission Limit [FCC Part 15 Subpart B 15.109(a)].....	20
4.4 Test Configuration.....	20
4.5 Operating Condition of EUT.....	20
4.6 Test Procedures.....	21
4.7 Test Results.....	21
5 DEVIATION TO TEST SPECIFICATIONS.....	28
6 DEBUG DESCRIPTION.....	29

TEST REPORT FOR FCC CERTIFICATE

Applicant : Hisense Electric Co., Ltd.
 Manufacturer : Hisense Electric Co., Ltd.
 EUT Description : LCD TV

Model No.	Serial No.	Brand	Power Supply
LTDN47T18GUS	E2009101301	Hisense	120V/60Hz
NX4703L120	--	NEXUS	

Test Procedure Used:

*FCC RULES AND REGULATIONS PART 15 SUBPART B CLASS B OCTOBER 2008
 AND ANSI C63.4-2003*

The device described above is tested by Audix Technology (Shanghai) Co., Ltd. to determine the maximum emission levels emanating from the device. The maximum emission levels are compared to the FCC Part 15 Subpart B (Class B) limits both radiated and conducted emissions.

The test results are contained in this test report and Audix Technology (Shanghai) Co., Ltd. is assumed full responsibility for the accuracy and completeness of these measurements. This report shows that the EUT (M/N: Refer to Sec.2.1; S/N: Refer to Sec.2.1) which was tested in 3m anechoic chamber Oct 13 - 22, 2009 is technically compliance with the FCC official limits also.

This report applies to above tested sample only. This report shall not be reproduced in part without written approval of Audix Technology (Shanghai) Co., Ltd.

This report contains data that are not covered by the NVLAP accreditation.

This report must not be used by the client to claim product certification, approval, or endorsement by NVLAP, NIST, or any agency of the federal government.

The test results for EUT's TV functions are contained in No.F09106, a Verification report.

Date of Test : Oct 13 - 22, 2009 Date of Report : Nov 05, 2009

Producer : Zeno Gu
 ZENO GU / Assistant

Review : Dio Yang
 DIO YANG / Deputy Assistant Manager

 For and on behalf of
 Audix Technology (Shanghai) Co., Ltd.

Signatory : Sammy Chen
 Authorized Signature EMC SAMMY CHEN / Assistant Manager

1 SUMMARY OF STANDARDS AND RESULTS

1.1 Description of Standards and Results

The EUT have been tested according to the applicable standards as referenced below:

Description of Test Item	Standard	Limits	Results
EMISSION			
Conducted Disturbance at the Mains Terminal	FCC RULES AND REGULATIONS PART 15 SUBPART B OCTOBER 2008 AND ANSI C63.4-2003	15.107(a) Class B	Pass
Radiated Disturbance	FCC RULES AND REGULATIONS PART 15 SUBPART B OCTOBER 2008 AND ANSI C63.4-2003	15.109(a) Class B	Pass

2 GENERAL INFORMATION

2.1 Description of Equipment Under Test

Description : LCD TV

Type of EUT : Production Pre-product Pro-type

Model No.	Serial No.	Brand
LTDN47T18GUS	E2009101301	Hisense
NX4703L120	--	NEXUS

Note 1 : The above models are all the same except for the different model number and brand.

Note 2 : The LTDN47T18GUS was tested and recorded in this report.

Applicant : Hisense Electric Co., Ltd.
No.218 Qianwangang Road, Economy & Technology Development Zone, Qingdao, China

Manufacturer : Hisense Electric Co., Ltd.
No.218 Qianwangang Road, Economy & Technology Development Zone, Qingdao, China

LCD Panel : Manufacturer : LG Display
M/N : LC470WUL (SB) (T1)

Tuner : Manufacturer : XuGuang Tech. Co., Ltd.
M/N : DVT-8ADC1/W41F9ROH

Max Resolution : 1360*768@60Hz

D-Sub Cable : Shielded, Detachable, 1.85m,
with two cores on cable

HDMI Cable : Shielded, Detachable, 1.85m,
without core on cable

Power Cord : Unshielded, Detachable, 1.80m

Remark:

The EUT is a LCD TV which input/output ports as follows:

Bottom View:

- (1) One component of YPbPr#2 Port
Connected with DVD#1
- (2) One component of YPbPr#2 Audio Port
Connected with DVD#1
- (3) One HDMI#4 Port
Connected with DVD#1

- (4) One COAXIAL Port
Connected with DVD#1
- (5) One Earphone Port
Connected with Earphone
- (6) One Service Port
Do not Open to Customer

Side Port:

- (7) One component of YPbPr#1 Port
Connected with DVD#2
- (8) One component of YPbPr#1 Audio Port
Connected with DVD#2
- (9) One ANT Port
Connected with TV SG/ATSC SG
- (10) One VGA Port
Connected with PC
- (11) One VGA Audio Port
Connected with PC
- (12) One HDMI#1 Port
Connected with DVD#2
- (13) One HDMI#2 Port
Connected with DVD#3
- (14) One HDMI#3 Port
Connected with PC
- (15) One component of Audio out Port
Connected with Speaker

2.2 Peripherals

2.2.1 PC

Manufacturer : HP
Model Number : dx7200MT
Serial Number : CNG622017W
Power Cord : Unshielded, Detachable, 1.8m
Certificate : FCC DoC; CE/EMC; VCCI; C-Tick; UL
BSMI (R33001) 3C (A000111)
MIC (E-A011-04-2659(B))

2.2.2 Printer

Manufacturer : HP
Model Number : C3990A
Serial Number : JPZX020487
Data Cable : Shielded, detachable, 1.5m
Certificate : GS, CE/EMC, C-Tick, FCC DoC

2.2.3 Keyboard

Manufacturer : Microsoft
Model Number : RT2300
Serial Number : 7668200662248
Data Cable : Shielded, undetachable ,1.8m
Certificate : CE/EMC, FCC DoC, VCCI, MIC, C-Tick,
BSMI

2.2.4 Mouse

Manufacturer : Microsoft
Model Number : RT2300
Serial Number : 6965712071551
Data Cable : Shielded, undetachable, 1.8m.
Certificate : CE/EMC, FCC DoC, VCCI, MIC, C-Tick,
BSMI

2.2.5 Modem

Manufacturer : TP-LINK
Model Number : TM-EC5658V
Serial Number : 07123301053
Data Cable : Shielded, Detachable, 1.8m
Certificate : FCC DoC, CE/EMC, CCC

2.2.6 Earphone

Manufacturer : SONY
Model Number : MDR-E808
Serial Number : 1808030805305506

2.2.7 TV Signal Generator

Manufacturer : FLUKE
Model Number : 54200m01
Serial Number : 814008
Data Cable : Shielded, detachable, 2.0m
Power Cord : Unshielded, detachable, 2.0m
Certificate : CE/EMC, FCC DoC, CCC

2.2.8 ATSC Signal Generator

Manufacturer : SENCORE
Model Number : ATSC997
Serial Number : 6790071

2.2.9 DVD#1

Manufacturer : PHILIPS
Model Number : DVP3986K/93
Serial Number : KX1A0902120108
Certificate : FCC DoC, CE/EMC, CCC

2.2.10 DVD#2

Manufacturer : PHILIPS
Model Number : DVP3986K/93
Serial Number : KX1A0902120082
Certificate : FCC DoC, CE/EMC, CCC

2.2.11 DVD#3

Manufacturer : LG
Model Number : DF9921N
Serial Number : 3850R-N846W
Certificate : FCC DoC, CE/EMC, CCC

2.2.12 Speaker

Manufacturer : DIBA
Model Number : T520
Serial Number : 10628

2.3 Description of Test Facility

Site Description (Semi-Anechoic Chamber) : Sept. 17, 1998 file on
Apr 29, 2009 Renewed
Federal Communications Commission
FCC Engineering Laboratory
7435 Oakland Mills Road
Columbia, MD 21046, USA

Name of Firm : Audix Technology (Shanghai) Co., Ltd.

Site Location : 3F 34Bldg 680 Guiping Rd,
Caohejing Hi-Tech Park,
Shanghai 200233, China

NVLAP Lab Code : 200371-0

2.4 Measurement Uncertainty

Conducted Emission Expanded Uncertainty: U = 1.26 dB
Radiated Emission Expanded Uncertainty : U = 3.02 dB

3 CONDUCTED EMISSION TEST

3.1.1 Test Equipment

The following test equipments are used during the conducted emission test in a shielded room:

Item	Type	Manufacturer	Model No.	Serial No.	Last Cal.	Next Cal.
1.	Test Receiver	R&S	ESCI	100841	Nov 21, 2008	Nov 21, 2009
2.	Artificial Mains Network (AMN)	R&S	ESH2-Z5	843890/011	Apr 02, 2009	Apr 02, 2010
3.	Line Impedance Stabilization Network (LISN)	Kyoritsu	KNW-407	8-1280-4	Apr 02, 2009	Apr 02, 2010
4.	50 Ω Coaxial Switch	Anritsu	MP59B	6200426389	Sep 19, 2009	Mar 19, 2010
5.	50 Ω Terminator	Anritsu	BNC	001	Apr 02, 2009	Apr 02, 2010
6.	Software	Audix	E3	SET00200 9804M592	--	--

3.2 Block Diagram of Test Setup

3.2.1 EUT & Peripherals

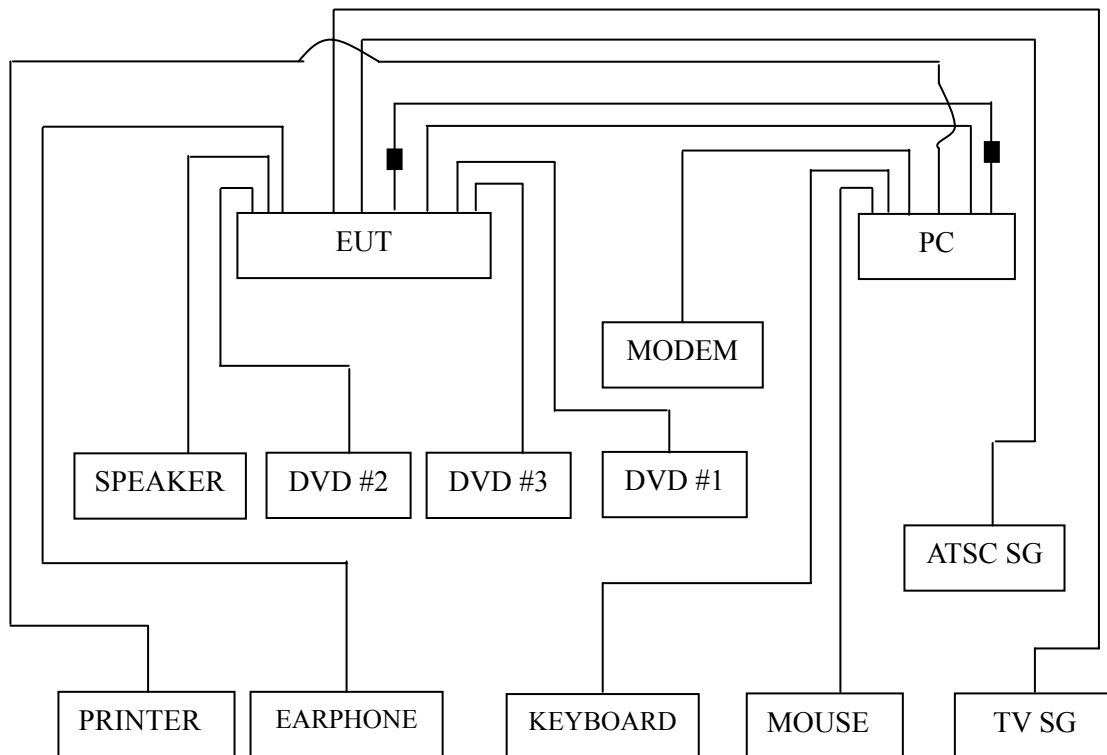

■ : Ferrite core

3.2.2 Conducted Disturbance Test Setup

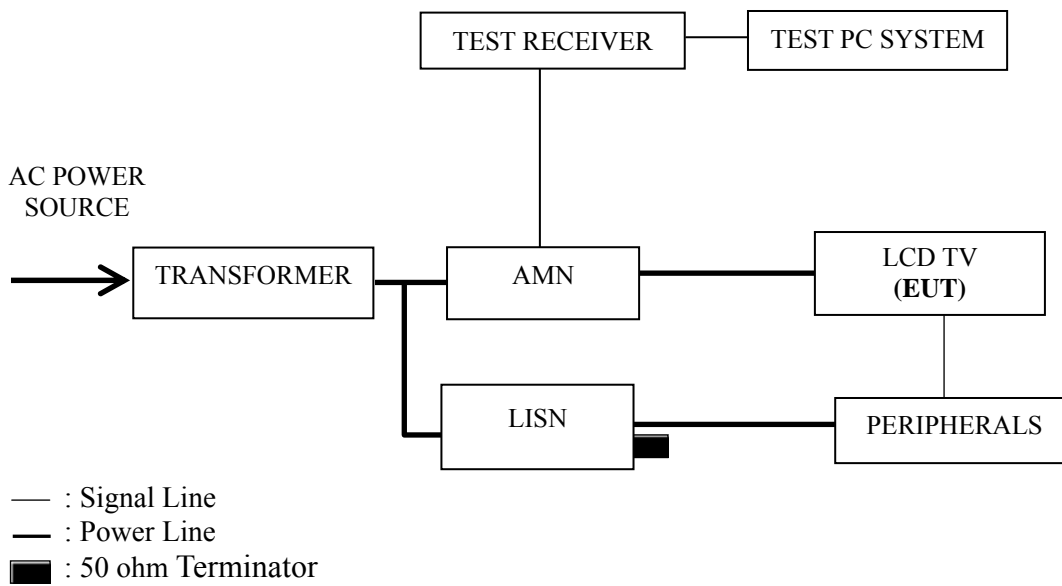

3.3 Conducted Emission Limit [FCC Part 15 Subpart B 15.107(a)]

Frequency Range (MHz)	Limits dB (μ V)	
	Quasi-peak	Average
0.15 ~ 0.5	66~56	56~46
0.5 ~ 5	56	46
5 ~ 30	60	50

NOTE 1 – The lower limit shall apply at the transition frequencies.
 NOTE 2 – The limit decreases linearly with the logarithm of the frequency in the range 0.15 MHz~0.50 MHz

3.4 Test Configuration

The EUT (listed in Sec.2.1) and the peripherals (listed in Sec 2.2) were installed as shown on Sec.3.2 to meet FCC requirement and operating in a manner that tends to maximize its emission level in a normal application.

3.5 Operating Condition of EUT

3.5.1 Setup the EUT and peripherals as shown in Sec. 3.2.

3.5.2 Turn on the power of all equipments and the EUT.

3.5.3 Set the contrast & brightness of EUT to maximum.

3.5.4 PC system ran the self-test program “EMC Test” by windows XP and sent “H” characters to EUT through graphic card, the EUT’s screen displayed and filled with “H” pattern by its resolution (Via D-Sub & HDMI Input).

3.5.5 Repeat above procedure from 3.5.3 to 3.5.4 for difference test mode.

3.5.6 The other peripherals devices were driven and operated during the test.

3.5.7 The test modes are as follows:

Test Mode
D-Sub 640*480@60Hz
D-Sub 1024*768@60Hz
D-Sub 1360*768@60Hz
HDMI 640*480@60Hz
HDMI 1024*768@60Hz
HDMI 1360*768@60Hz

3.6 Test Procedures

The EUT and peripherals were connected to the power mains through an Artificial Mains Network (AMN). This provided a 50 ohm coupling impedance for the measuring equipment.

Both sides of AC line (Line & Neutral) were checked for maximum conducted interference. In order to find the maximum emission, the relative positions of equipment and all of the interface cables were changed or manipulated according to ANSI C63.4:2003 during conducted emission test.

The bandwidth of R&S Test Receiver ESCI was set at 9 kHz.

The frequency range from 150 kHz to 30 MHz was checked.

The test modes were done on conducted disturbance test and all the test results are listed in Sec. 3.7.

3.7 Test Results

< **PASS** >

The frequency and amplitude of the highest conducted emission relative to the limit is reported. All emissions not reported below are too low against the prescribed limits.

Test Mode	Data Page
D-Sub 640*480@60Hz	P13
D-Sub 1024*768@60Hz	P14
D-Sub 1360*768@60Hz	P15
HDMI 640*480@60Hz	P16
HDMI 1024*768@60Hz	P17
HDMI 1360*768@60Hz	P18

NOTE 1 – Factor = Cable Loss + AMN Factor.

NOTE 2 – Emission Level = Meter Reading + Factor.

NOTE 3 – “QP” means “Quasi-Peak” values, “AV” means “Average” values.

NOTE 4 – The worst case is for D-Sub 640*480@60Hz test mode. The worst emission is detected at 8.323 MHz (Quasi-Peak) with corrected signal level of 43.38 dB (μV) (limit is 60.00 dB (μV)), when the Neutral of the EUT is connected to AMN.

EUT : LCD TV Temperature : 22°C

Model No. : LTDN47T18GUS Humidity : 48%RH

Serial No. : E2009101301 Date of Test : Oct 13, 2009

Test Mode : D-Sub 640*480@60Hz

Test Line	Frequency (MHz)	Meter Reading dB(μ V)	Factor (dB)	Emission Level dB(μ V)	Limits dB(μ V)	Margin (dB)	Remark	
Line	0.280	30.96	0.25	31.21	60.81	29.60	QP	
	0.385	29.46	0.27	29.73	58.17	28.44		
	0.943	37.07	0.30	37.37	56.00	18.63		
	1.153	32.99	0.32	33.31	56.00	22.69		
	8.822	39.46	0.48	39.94	60.00	20.06		
	9.966	37.60	0.49	38.09	60.00	21.91		
	Line	0.280	20.47	0.25	20.72	50.81	30.09	AV
		0.385	22.82	0.27	23.09	48.17	25.08	
		0.943	18.56	0.30	18.86	46.00	27.14	
		1.153	21.23	0.32	21.55	46.00	24.45	
8.822		30.83	0.48	31.31	50.00	18.69		
9.966		29.90	0.49	30.39	50.00	19.61		
Neutral	0.252	30.45	0.22	30.67	61.69	31.02	QP	
	0.499	29.82	0.26	30.08	56.01	25.93		
	0.890	33.58	0.29	33.87	56.00	22.13		
	4.822	28.13	0.45	28.58	56.00	27.42		
	8.323	42.89	0.49	43.38	60.00	16.62		
	10.564	38.67	0.53	39.20	60.00	20.80		
	Neutral	0.252	19.92	0.22	20.14	51.69	31.55	AV
		0.499	16.63	0.26	16.89	46.01	29.12	
		0.890	20.76	0.29	21.05	46.00	24.95	
		4.822	17.22	0.45	17.67	46.00	28.33	
8.323		32.13	0.49	32.62	50.00	17.38		
10.564	29.34	0.53	29.87	50.00	20.13			

TEST ENGINEER: HUGH HUANG

EUT : LCD TV Temperature : 22°C

Model No. : LTDN47T18GUS Humidity : 48%RH

Serial No. : E2009101301 Date of Test : Oct 13, 2009

Test Mode : D-Sub 1024*768@60Hz

Test Line	Frequency (MHz)	Meter Reading dB(μ V)	Factor (dB)	Emission Level dB(μ V)	Limits dB(μ V)	Margin (dB)	Remark
Line	0.280	30.92	0.25	31.17	60.81	29.64	QP
	0.489	29.16	0.29	29.45	56.19	26.74	
	0.899	35.05	0.29	35.34	56.00	20.66	
	1.153	33.15	0.32	33.47	56.00	22.53	
	8.148	40.16	0.48	40.64	60.00	19.36	
	9.861	40.45	0.49	40.94	60.00	19.06	
	0.280	20.47	0.25	20.72	50.81	30.09	AV
	0.489	17.03	0.29	17.32	46.19	28.87	
	0.899	22.00	0.29	22.29	46.00	23.71	
	1.153	21.03	0.32	21.35	46.00	24.65	
	8.148	31.26	0.48	31.74	50.00	18.26	
	9.861	30.31	0.49	30.80	50.00	19.20	
Neutral	0.256	30.41	0.22	30.63	61.56	30.93	QP
	0.494	29.70	0.26	29.96	56.10	26.14	
	0.899	35.21	0.29	35.50	56.00	20.50	
	1.153	33.27	0.32	33.59	56.00	22.41	
	8.729	42.22	0.50	42.72	60.00	17.28	
	14.986	34.33	0.67	35.00	60.00	25.00	
	0.256	18.79	0.22	19.01	51.56	32.55	AV
	0.494	16.70	0.26	16.96	46.10	29.14	
	0.899	22.04	0.29	22.33	46.00	23.67	
	1.153	21.51	0.32	21.83	46.00	24.17	
	8.729	32.22	0.50	32.72	50.00	17.28	
	14.986	23.10	0.67	23.77	50.00	26.23	

TEST ENGINEER: HUGH HUANG

EUT : LCD TV Temperature : 22°C

Model No. : LTDN47T18GUS Humidity : 48%RH

Serial No. : E2009101301 Date of Test : Oct 13, 2009

Test Mode : D-Sub 1360*768@60Hz

Test Line	Frequency (MHz)	Meter Reading dB(μV)	Factor (dB)	Emission Level dB(μV)	Limits dB(μV)	Margin (dB)	Remark
Line	0.253	31.42	0.24	31.66	61.64	29.98	QP
	0.385	29.65	0.27	29.92	58.17	28.25	
	0.899	35.37	0.29	35.66	56.00	20.34	
	4.926	28.84	0.44	29.28	56.00	26.72	
	8.592	42.64	0.48	43.12	60.00	16.88	
	11.933	32.87	0.58	33.45	60.00	26.55	
	0.253	20.90	0.24	21.14	51.64	30.50	AV
	0.385	23.20	0.27	23.47	48.17	24.70	
	0.899	22.22	0.29	22.51	46.00	23.49	
	4.926	18.57	0.44	19.01	46.00	26.99	
	8.592	32.40	0.48	32.88	50.00	17.12	
	11.933	24.98	0.58	25.56	50.00	24.44	
Neutral	0.249	30.45	0.22	30.67	61.78	31.11	QP
	0.476	28.89	0.26	29.15	56.41	27.26	
	0.890	33.97	0.29	34.26	56.00	21.74	
	1.153	33.30	0.32	33.62	56.00	22.38	
	8.729	42.01	0.50	42.51	60.00	17.49	
	14.672	34.70	0.66	35.36	60.00	24.64	
	0.249	20.10	0.22	20.32	51.78	31.46	AV
	0.476	14.93	0.26	15.19	46.41	31.22	
	0.890	20.83	0.29	21.12	46.00	24.88	
	1.153	21.33	0.32	21.65	46.00	24.35	
	8.729	32.24	0.50	32.74	50.00	17.26	
	14.672	23.02	0.66	23.68	50.00	26.32	

TEST ENGINEER: HUGH HUANG

EUT : LCD TV Temperature : 22°C

Model No. : LTDN47T18GUS Humidity : 48%RH

Serial No. : E2009101301 Date of Test : Oct 13, 2009

Test Mode : HDMI 640*480@60Hz

Test Line	Frequency (MHz)	Meter Reading dB(μ V)	Factor (dB)	Emission Level dB(μ V)	Limits dB(μ V)	Margin (dB)	Remark
Line	0.253	31.08	0.24	31.32	61.64	30.32	QP
	0.385	29.64	0.27	29.91	58.17	28.26	
	0.943	35.46	0.30	35.76	56.00	20.24	
	2.809	23.56	0.39	23.95	56.00	32.05	
	8.637	42.88	0.48	43.36	60.00	16.64	
	14.986	33.79	0.71	34.50	60.00	25.50	
	0.253	21.08	0.24	21.32	51.64	30.32	AV
	0.385	23.64	0.27	23.91	48.17	24.26	
	0.943	17.51	0.30	17.81	46.00	28.19	
	2.809	14.08	0.39	14.47	46.00	31.53	
	8.637	30.77	0.48	31.25	50.00	18.75	
	14.986	22.58	0.71	23.29	50.00	26.71	
Neutral	0.253	29.99	0.22	30.21	61.64	31.43	QP
	0.385	26.54	0.24	26.78	58.17	31.39	
	0.943	35.14	0.30	35.44	56.00	20.56	
	3.107	29.84	0.41	30.25	56.00	25.75	
	8.412	41.14	0.49	41.63	60.00	18.37	
	14.986	34.27	0.67	34.94	60.00	25.06	
	0.253	19.60	0.22	19.82	51.64	31.82	AV
	0.385	19.95	0.24	20.19	48.17	27.98	
	0.943	16.85	0.30	17.15	46.00	28.85	
	3.107	17.14	0.41	17.55	46.00	28.45	
	8.412	30.54	0.49	31.03	50.00	18.97	
	14.986	23.53	0.67	24.20	50.00	25.80	

TEST ENGINEER: HUGH HUANG

EUT : LCD TV Temperature : 22°C

Model No. : LTDN47T18GUS Humidity : 48%RH

Serial No. : E2009101301 Date of Test : Oct 13, 2009

Test Mode : HDMI 1024*768@60Hz

Test Line	Frequency (MHz)	Meter Reading dB(μ V)	Factor (dB)	Emission Level dB(μ V)	Limits dB(μ V)	Margin (dB)	Remark
Line	0.256	31.17	0.24	31.41	61.56	30.15	QP
	0.381	29.17	0.27	29.44	58.25	28.81	
	0.943	35.97	0.30	36.27	56.00	19.73	
	4.407	29.36	0.44	29.80	56.00	26.20	
	8.235	42.20	0.48	42.68	60.00	17.32	
	14.986	33.57	0.71	34.28	60.00	25.72	
	0.256	20.19	0.24	20.43	51.56	31.13	AV
	0.381	24.71	0.27	24.98	48.25	23.27	
	0.943	17.86	0.30	18.16	46.00	27.84	
	4.407	17.12	0.44	17.56	46.00	28.44	
	8.235	30.33	0.48	30.81	50.00	19.19	
	14.986	23.17	0.71	23.88	50.00	26.12	
Neutral	0.249	30.06	0.22	30.28	61.78	31.50	QP
	0.505	29.52	0.26	29.78	56.00	26.22	
	0.943	36.27	0.30	36.57	56.00	19.43	
	4.721	30.73	0.45	31.18	56.00	24.82	
	8.637	40.23	0.50	40.73	60.00	19.27	
	14.986	33.83	0.67	34.50	60.00	25.50	
	0.249	19.99	0.22	20.21	51.78	31.57	AV
	0.505	14.37	0.26	14.63	46.00	31.37	
	0.943	17.58	0.30	17.88	46.00	28.12	
	4.721	20.45	0.45	20.90	46.00	25.10	
	8.637	30.40	0.50	30.90	50.00	19.10	
	14.986	22.72	0.67	23.39	50.00	26.61	

TEST ENGINEER: HUGH HUANG

EUT : LCD TV Temperature : 22°C

Model No. : LTDN47T18GUS Humidity : 48%RH

Serial No. : E2009101301 Date of Test : Oct 13, 2009

Test Mode : HDMI 1360*768@60Hz

Test Line	Frequency (MHz)	Meter Reading dB(μ V)	Factor (dB)	Emission Level dB(μ V)	Limits dB(μ V)	Margin (dB)	Remark
Line	0.253	31.33	0.24	31.57	61.64	30.07	QP
	0.385	30.28	0.27	30.55	58.17	27.62	
	0.943	36.68	0.30	36.98	56.00	19.02	
	4.549	28.70	0.44	29.14	56.00	26.86	
	8.235	42.60	0.48	43.08	60.00	16.92	
	14.986	32.77	0.71	33.48	60.00	26.52	
	0.253	21.37	0.24	21.61	51.64	30.03	AV
	0.385	24.18	0.27	24.45	48.17	23.72	
	0.943	18.22	0.30	18.52	46.00	27.48	
	4.549	17.10	0.44	17.54	46.00	28.46	
	8.235	31.04	0.48	31.52	50.00	18.48	
	14.986	21.71	0.71	22.42	50.00	27.58	
Neutral	0.253	30.00	0.22	30.22	61.64	31.42	QP
	0.499	29.68	0.26	29.94	56.01	26.07	
	0.899	33.88	0.29	34.17	56.00	21.83	
	4.407	25.95	0.45	26.40	56.00	29.60	
	8.501	42.47	0.50	42.97	60.00	17.03	
	14.986	33.48	0.67	34.15	60.00	25.85	
	0.253	19.56	0.22	19.78	51.64	31.86	AV
	0.499	16.62	0.26	16.88	46.01	29.13	
	0.899	20.86	0.29	21.15	46.00	24.85	
	4.407	17.00	0.45	17.45	46.00	28.55	
	8.501	30.85	0.50	31.35	50.00	18.65	
	14.986	22.24	0.67	22.91	50.00	27.09	

TEST ENGINEER: HUGH HUANG

4 RADIATED EMISSION TEST

4.1 Test Equipment

The following test equipments are used during the radiated emission test in a semi-anechoic chamber:

Item	Type	Manufacturer	Model No.	Serial No.	Last Cal.	Next Cal.
1.	Test Receiver	R&S	ESVS10	844594/001	Mar 07, 2009	Mar 07, 2010
2.	Preamplifier	Agilent	8447D	2944A10548	Sep 19, 2009	Mar 19, 2010
3.	Bi-log Antenna	TESEQ	CBL6112D	23193	May 14, 2008	May 14, 2010
4.	Spectrum	Agilent	E7405A	MY45106600	May 19, 2009	May 19, 2010
5.	Software	Audix	E3	SET00200 9912M295-2	--	--

4.2 Block Diagram of Test Setup

4.2.1 EUT and Peripherals

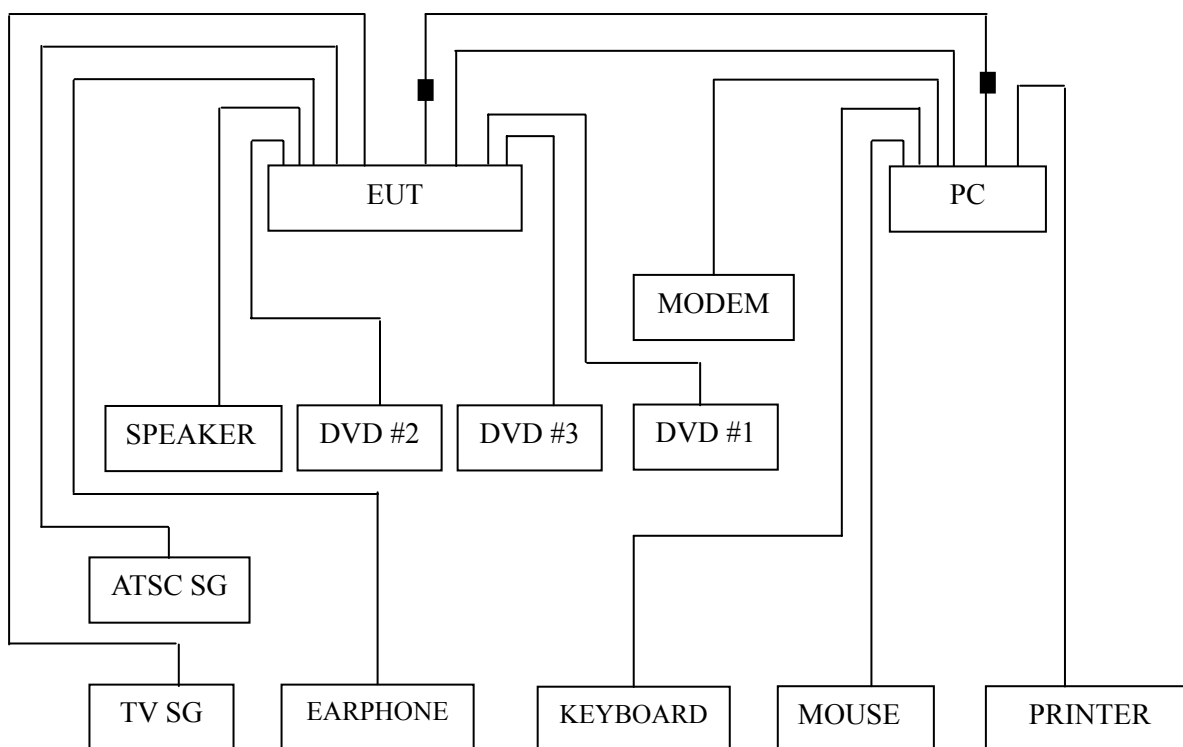

■ : Ferrite core

4.2.2 Radiated emission test setup

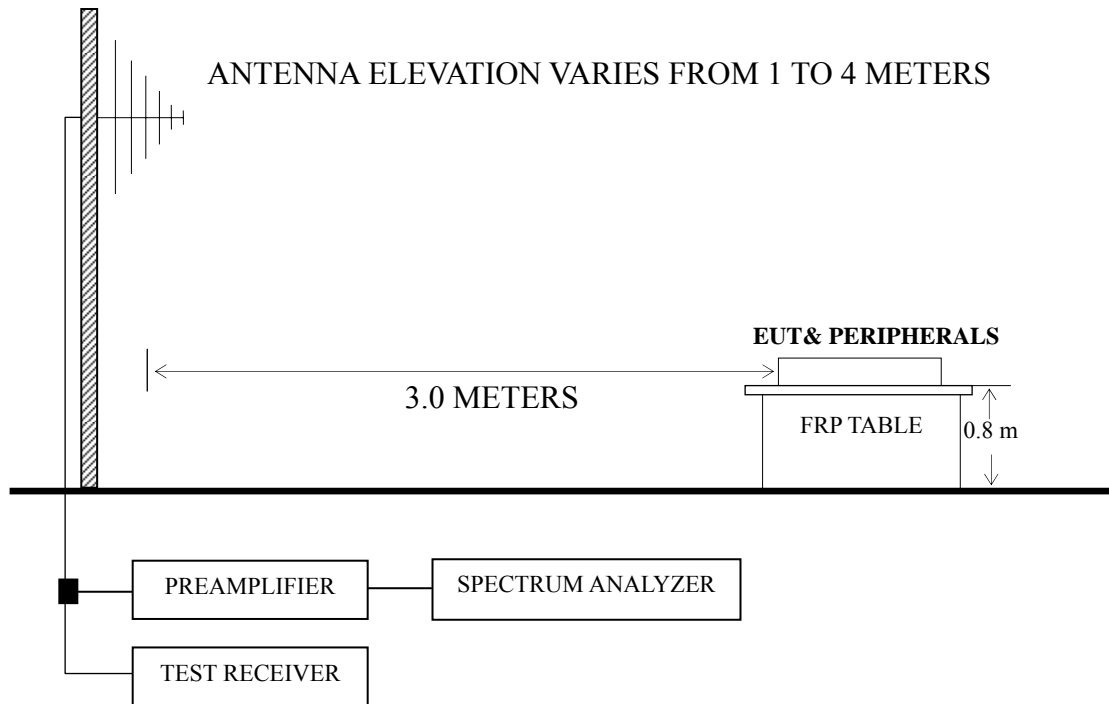

■ : 50 ohm Coaxial Switch

4.3 Radiated Emission Limit [FCC Part 15 Subpart B 15.109(a)]

Frequency (MHz)	Distance (m)	Field strength limits	
		($\mu\text{V/m}$)	dB ($\mu\text{V/m}$)
30 ~ 88	3	100	40.0
88 ~ 216	3	150	43.5
216 ~ 960	3	200	46.0
Above 960	3	500	54.0

NOTE 1 - Emission Level dB ($\mu\text{V/m}$) = 20 log Emission Level ($\mu\text{V/m}$)

NOTE 2 - The tighter limit applies at the band edges.

NOTE 3 - Distance refers to the distance in meters between the measuring instrument antenna and the closed point of any part of the device or system.

NOTE 4 - The limits shown are based on Quasi-peak value detector.

4.4 Test Configuration

The configuration of the EUT and peripherals are same as those used in conducted emission test.

Please refer to Sec.3.4.

4.5 Operating Condition of EUT

Same as conducted emission test which is listed in Sec.3.5, except for the test setup replaced by Sec.4.2.

4.6 Test Procedures

The EUT and peripherals were placed on a FRP turntable that is 0.8 meter above ground. The FRP turntable rotated 360 degrees to determine the position of the maximum emission level. The EUT was set 3 meters away from the receiving antenna, which was mounted on an antenna tower. Broadband antenna (Calibrated Bilog Antenna) was used as receiving antenna. The antenna moved up and down between 1 meter and 4 meters to find out the maximum emission level. Both horizontal and vertical polarizations of the antenna were set on measurement. In order to find the maximum emission, all of the interference cables were manipulated according to ANSI C63.4:2003 requirements during radiated emission test.

The bandwidth of Test Receiver R&S ESVS10 was set at 120 kHz.

The frequency range from 30 MHz to 1000MHz was checked for all test modes.

The test modes were done on radiated disturbance test and all the test results are listed in Sec.4.7.

4.7 Test Results

<PASS>

The frequency and amplitude of the highest radiated emission relative the limit is reported. All the emissions not reported below are too low against the FCC limit.

Test Mode	Data Page
D-Sub 640*480@60Hz	P22
D-Sub 1024*768@60Hz	P23
D-Sub 1360*768@60Hz	P24
HDMI 640*480@60Hz	P25
HDMI 1024*768@60Hz	P26
HDMI 1360*768@60Hz	P27

NOTE 1 – Emission Level = Antenna Factor + Cable Loss + Meter Reading.

NOTE 2 – The emission levels that are 20dB below the official limit are not reported.

NOTE 3 – 0° was the table front facing the antenna. Degree is calculated from 0° clockwise facing the antenna.

NOTE 4 – The worst case is for HDMI 1024*768@60Hz test mode. The worst emission at horizontal polarization was detected at 83.350 MHz with corrected signal level of 36.97 dB ($\mu\text{V}/\text{m}$) (limit is 40.00dB ($\mu\text{V}/\text{m}$)), when the antenna was 2.00 m height and the turntable was at 260°. The worst emission at vertical polarization was detected at 33.880 MHz with corrected signal level of 36.95dB ($\mu\text{V}/\text{m}$) (limit is 40.00 dB ($\mu\text{V}/\text{m}$)), when the antenna was 2.00 m height and the turntable was at 80°.

EUT : LCD TV Temperature : 22°C

Model No. : LTDN47T18GUS Humidity : 60%RH

Serial No. : E2009101301 Date of Test : Oct 22, 2009

Test Mode : D-Sub 640*480@60Hz

Polarization	Frequency (MHz)	Meter Reading dB (μV)	Antenna Factor (dB/m)	Cable Loss (dB)	Emission Level dB (μV/m)	Limits dB (μV/m)	Margin (dB)
Horizontal	41.640	22.25	13.02	0.67	35.94	40.00	4.06
	70.740	24.46	6.58	0.87	31.91	40.00	8.09
	223.030	24.26	11.80	1.62	37.68	46.00	8.32
	492.690	18.46	17.80	2.41	38.67	46.00	7.33
	594.540	20.01	19.14	2.72	41.87	46.00	4.13
	817.640	17.66	20.87	3.24	41.77	46.00	4.23
Vertical	33.880	9.82	17.44	0.64	27.90	40.00	12.10
	70.740	21.68	6.58	0.87	29.13	40.00	10.87
	223.030	25.01	11.80	1.62	38.43	46.00	7.57
	446.130	16.98	17.17	2.31	36.46	46.00	9.54
	521.790	22.03	18.18	2.51	42.72	46.00	3.28
	965.080	14.75	22.16	3.55	40.46	54.00	13.54

TEST ENGINEER: RAVEN JIN

EUT : LCD TV Temperature : 22°C

Model No. : LTDN47T18GUS Humidity : 60%RH

Serial No. : E2009101301 Date of Test : Oct 22, 2009

Test Mode : D-Sub1024*768@60Hz

Polarization	Frequency (MHz)	Meter Reading dB (μ V)	Antenna Factor (dB/m)	Cable Loss (dB)	Emission Level dB (μ V/m)	Limits dB (μ V/m)	Margin (dB)
Horizontal	69.770	26.28	6.50	0.86	33.64	40.00	6.36
	119.240	23.26	12.97	1.14	37.37	43.50	6.13
	223.030	27.41	11.80	1.62	40.83	46.00	5.17
	446.130	18.26	17.17	2.31	37.74	46.00	8.26
	518.880	21.14	18.15	2.49	41.78	46.00	4.22
	890.390	17.04	21.60	3.42	42.06	46.00	3.94
Vertical	31.940	17.19	18.49	0.64	36.32	40.00	3.68
	69.770	25.55	6.50	0.86	32.91	40.00	7.09
	120.000	23.20	13.00	1.15	37.35	43.50	6.15
	223.030	25.64	11.80	1.62	39.06	46.00	6.94
	519.100	20.10	18.15	2.49	40.74	46.00	5.26
	817.640	17.09	20.87	3.24	41.20	46.00	4.80

TEST ENGINEER: RAVEN JIN

EUT : LCD TV Temperature : 22°C

Model No. : LTDN47T18GUS Humidity : 60%RH

Serial No. : E2009101301 Date of Test : Oct 22, 2009

Test Mode : D-Sub1360*768@60Hz

Polarization	Frequency (MHz)	Meter Reading dB (μV)	Antenna Factor (dB/m)	Cable Loss (dB)	Emission Level dB (μV/m)	Limits dB (μV/m)	Margin (dB)
Horizontal	30.970	6.33	19.03	0.63	25.99	40.00	14.01
	69.770	22.16	6.50	0.86	29.52	40.00	10.48
	223.030	25.57	11.80	1.62	38.99	46.00	7.01
	446.130	16.43	17.17	2.31	35.91	46.00	10.09
	688.630	18.33	19.65	2.92	40.90	46.00	5.10
	817.640	17.48	20.87	3.24	41.59	46.00	4.41
Vertical	33.880	17.85	17.44	0.64	35.93	40.00	4.07
	69.770	25.61	6.50	0.86	32.97	40.00	7.03
	120.210	25.95	12.98	1.15	40.08	43.50	3.42
	293.840	20.88	13.79	1.85	36.52	46.00	9.48
	489.780	18.97	17.78	2.41	39.16	46.00	6.84
	890.390	17.79	21.60	3.42	42.81	46.00	3.19

TEST ENGINEER: RAVEN JIN

EUT : LCD TV Temperature : 22°C

Model No. : LTDN47T18GUS Humidity : 60%RH

Serial No. : E2009101301 Date of Test : Oct 22, 2009

Test Mode : HDMI 1024*768@60Hz

Polarization	Frequency (MHz)	Meter Reading dB (μ V)	Antenna Factor (dB/m)	Cable Loss (dB)	Emission Level dB (μ V/m)	Limits dB (μ V/m)	Margin (dB)
Horizontal	33.880	17.32	17.44	0.64	35.40	40.00	4.60
	83.350	27.70	8.30	0.97	36.97	40.00	3.03
	223.030	24.81	11.80	1.62	38.23	46.00	7.77
	411.210	15.31	16.64	2.23	34.18	46.00	11.82
	543.130	21.18	18.49	2.58	42.25	46.00	3.75
	890.390	15.92	21.60	3.42	40.94	46.00	5.06
Vertical	33.880	18.87	17.44	0.64	36.95	40.00	3.05
	69.770	25.30	6.50	0.86	32.66	40.00	7.34
	121.180	23.87	12.95	1.15	37.97	43.50	5.53
	295.780	21.70	13.84	1.86	37.40	46.00	8.60
	594.540	19.85	19.14	2.72	41.71	46.00	4.29
	892.330	16.97	21.63	3.42	42.02	46.00	3.98

TEST ENGINEER: RAVEN JIN

EUT : LCD TV Temperature : 22°C

Model No. : LTDN47T18GUS Humidity : 60%RH

Serial No. : E2009101301 Date of Test : Oct 22, 2009

Test Mode : HDMI 1360*768@60Hz

Polarization	Frequency (MHz)	Meter Reading dB (μ V)	Antenna Factor (dB/m)	Cable Loss (dB)	Emission Level dB (μ V/m)	Limits dB (μ V/m)	Margin (dB)
Horizontal	36.790	18.71	15.80	0.66	35.17	40.00	4.83
	69.770	22.63	6.50	0.86	29.99	40.00	10.01
	223.030	25.57	11.80	1.62	38.99	46.00	7.01
	446.130	15.03	17.17	2.31	34.51	46.00	11.49
	686.690	19.27	19.63	2.91	41.81	46.00	4.19
	895.240	16.97	21.67	3.42	42.06	46.00	3.94
Vertical	33.880	18.72	17.44	0.64	36.80	40.00	3.20
	70.740	25.59	6.58	0.87	33.04	40.00	6.96
	121.180	26.16	12.95	1.15	40.26	43.50	3.24
	293.840	22.19	13.79	1.85	37.83	46.00	8.17
	492.690	18.21	17.80	2.41	38.42	46.00	7.58
	890.390	17.68	21.60	3.42	42.70	46.00	3.30

TEST ENGINEER: RAVEN JIN

5 DEVIATION TO TEST SPECIFICATIONS

None.

6 DEBUG DESCRIPTION

The following components are used during the countermeasure procedures:

Name	Specification	M/N	Manufacturer	Location
Aluminum foil	40*100	DBA40X100	Bilusi	See Internal Photo Figure 20
Gasket	4*5*3	DAA25X20	Bilusi	See Internal Photo Figure 21
Gasket	25*20*3	DAA25X20	Bilusi	See Internal Photo Figure 22
Ferrite Core	15*19*8	BNF-12\ZCAT1519-0830	Bilusi	See Internal Photo Figure 23
Gasket	50*6*6	--	Litong	See Internal Photo Figure 24

Note: We had required the applicant and manufacturer that all electrical and mechanical devices employed for spurious radiation suppression, including any modifications made during certification testing, must be incorporated in each unit marked

TEST ENGINEER:



(RAVEN JIN)