

FCC 47 CFR PART 15 SUBPART B
CERTIFICATION TEST REPORT

Product name: LED LCD TV

**MODEL No.: LC-43P3000U, LC-43P3000U+, LC-43P30+0U, LC-43P30+0U1,
LC-43P30+0U2, LC-43P3+0U, LC-43P3+0U1, LC-43P3+0U2("+ " would be
replaced by any number, letter or blank)**

FCC ID: W9HLCDD0079

REPORT NO: ES170623010E

ISSUE DATE: June 29, 2017

Prepared for

Hisense Electric Co., Ltd.
No. 218 Qianwangang Road, Economy&Technology
Development Zone, Qingdao 266071

Prepared by

EMTEK (SHENZHEN) CO., LTD.

Bldg 69, Majialong Industry Zone, Nanshan District, Shenzhen,
Guangdong, China
TEL: 86-755-26954280
FAX: 86-755-26954282

TABLE OF CONTENT

Test Report Description	Page
1. SUMMARY OF TEST RESULT	5
2. GENERAL INFORMATION	6
2.1. DESCRIPTION OF DEVICE (EUT)	6
2.2. DESCRIPTION OF TEST FACILITY	6
2.3. DESCRIPTION OF SUPPORT DEVICE	7
2.4. DESCRIPTION OF CABLE	7
2.5. MEASUREMENT UNCERTAINTY	7
3. MEASURING DEVICE AND TEST EQUIPMENT	8
4. CONDUCTED EMISSION MEASUREMENT	9
4.1. BLOCK DIAGRAM OF TEST SETUP	9
4.2. MEASURING STANDARD	9
4.3. POWER LINE CONDUCTED EMISSION LIMITS (CLASS B)	9
4.4. EUT CONFIGURATION ON MEASUREMENT	9
4.5. OPERATING CONDITION OF EUT	9
4.6. TEST PROCEDURE	10
4.7. MEASURING RESULTS	10
5. RADIATED EMISSION MEASUREMENT	13
5.1. BLOCK DIAGRAM OF TEST SETUP	13
5.2. MEASURING STANDARD	14
5.3. RADIATED EMISSION LIMITS (CLASS B)	14
5.4. EUT CONFIGURATION ON MEASUREMENT	14
5.5. OPERATING CONDITION OF EUT	14
5.6. TEST PROCEDURE	14
5.7. MEASURING RESULTS	15

TEST REPORT DESCRIPTION

Applicant : Hisense Electric Co., Ltd.
No. 218 Qianwangang Road, Economy&Technology Development Zone,
Qingdao 266071

Manufacturer : Hisense Electric Co., Ltd.
No. 218 Qianwangang Road, Economy&Technology Development Zone,
Qingdao 266071

Trademark : SHARP

EUT : LED LCD TV

Model No. : LC-43P3000U, LC-43P3000U+, LC-43P30+0U, LC-43P30+0U1,
LC-43P30+0U2, LC-43P3+0U, LC-43P3+0U1, LC-43P3+0U2 ("+" would be
replaced by any number, letter or blank)

Power Supply : 120V~60Hz, 75W

Measurement Procedure Used:

FCC Rules and Regulations Part 15: 2016 Subpart B Class B & FCC / ANSI C63.4-2014

The device described above is tested by EMTEK (SHENZHEN) CO., LTD. to determine the maximum emission levels emanating from the device and the severe levels of the device can endure and its performance criterion. The measurement results are contained in this test report and EMTEK (SHENZHEN) CO., LTD. is assumed full of responsibility for the accuracy and completeness of these measurements. Also, this report shows that the EUT (Equipment Under Test) is technically compliant with the FCC requirements.

This report applies to above tested sample only and shall not be reproduced in part without written approval of EMTEK (SHENZHEN) CO., LTD.

Date of Test : June 23, 2017 to June 28, 2017

Prepared by : 
Rui Zhou/Editor

Reviewer : 
Joe Xia/Supervisor

Approved & Authorized Signer : 
Lisa Wang/Manager



Modified Information

Version	Report No.	Revision Date	Summary
Ver.1.0	ES170623010E	/	Original Report

1. SUMMARY OF TEST RESULT

EMISSION		
Description of Test Item	Standard & Limits	Results
Conducted Disturbance at Mains Terminals	FCC Part 15, Subpart B, Class B ANSI C63.4: 2014	Pass
Radiated Disturbance	FCC Part 15, Subpart B, Class B ANSI C63.4: 2014	Pass
Note: N/A is an abbreviation for Not Applicable.		

2. GENERAL INFORMATION

2.1. Description of Device (EUT)

EUT	:	LED LCD TV
Model Number	:	LC-43P3000U, LC-43P3000U+, LC-43P30+0U, LC-43P30+0U1, LC-43P30+0U2, LC-43P3+0U, LC-43P3+0U1, LC-43P3+0U2("+" would be replaced by any number, letter or blank) (Note: All the model numbers are identical in circuitry and electrical, mechanical and physical construction; the only differences are the model no. for trading purpose. We prepare LC-43P3000U for test.)
Test Voltage	:	AC 120V/60Hz
Applicant Address	:	Hisense Electric Co., Ltd. No. 218 Qianwangang Road, Economy&Technology Development Zone, Qingdao 266071
Manufacturer Address	:	Hisense Electric Co., Ltd. No. 218 Qianwangang Road, Economy&Technology Development Zone, Qingdao 266071
Factory 1 Address	:	Guangdong Hisense Electronics Co., Ltd Zone B, No. 8 Hisense Road, Advanced Manufacturing Jiangsha Demonstration Park, Jiangmen City, Guangdong Province, PRC
Factory 2 Address	:	HISENSE ELECTRONICA MEXICO, S.A. DE C.V. Bld. Sharp #3510 Parque Industrial Rosarito, C.P. PLAYAS DE ROSARITO BC 22710, MEXICO
Date of Received	:	June 23, 2017
Date of Test	:	June 23, 2017 to June 28, 2017

2.2. Description of Test Facility

Site Description	:	
EMC Lab.	:	Accredited by CNAS, 2016.10.24 The certificate is valid until 2022.10.28 The Laboratory has been assessed and proved to be in compliance with CNAS-CL01:2006 (identical to ISO/IEC 17025:2005) The Certificate Registration Number is L2291. Accredited by TUV Rheinland Shenzhen 2010.5.25 The Laboratory has been assessed according to the requirements ISO/IEC 17025.
	:	Accredited by FCC, July 13, 2016 The Certificate Registration Number is 709623.
	:	Accredited by Industry Canada, November 15, 2015 The Certificate Registration Number is 4480A-2.
Name of Firm	:	EMTEK (SHENZHEN) CO., LTD.
Site Location	:	Bldg 69, Majialong Industry Zone, Nanshan District, Shenzhen, Guangdong, China

2.3. Description of Support Device

PC : Manufacturer: LENOVO
M/N: 9702
S/N: L3C4410
CE, FCC: DOC

Keyboard : Manufacturer: LENOVO
M/N: KU-0225
S/N:0585494
CE, FCC: DOC

Mouse : Manufacturer: LENOVO
M/N: MO28UOL
S/N:44G7862 068
CE, FCC: DOC

Dummy load : Manufacturer: Cultraview
M/N: CVNS1200

2.4. Description of Cable

Cables			
No.	Type	Length	Remark
1.	Power Cable	1.5 m	Unshielded
2.	HDMI Cable*3	0.8 m	Unshielded
3.	AV Cable	1.0 m	Unshielded

2.5. Measurement Uncertainty

Test Item	Uncertainty
Conducted Emission Uncertainty	: 2.96dB(9k~150kHz Conduction 1#) 2.74dB(150k-30MHz Conduction 1#)
Radiated Emission Uncertainty (3m Chamber)	: 3.78dB (30M~1GHz Polarize: H) 4.27dB (30M~1GHz Polarize: V) 4.46dB (1~6GHz)

3. MEASURING DEVICE AND TEST EQUIPMENT

3.1.1. Conducted Emission Test Equipment

EQUIPMENT TYPE	MFR	MODEL NUMBER	SERIAL NUMBER	LAST CAL.
Test Receiver	Rohde & Schwarz	ESCS30	828985/018	May 21, 2017
L.I.S.N.	Schwarzbeck	NNLK8129	8129203	May 20, 2017
50Ω Coaxial Switch	Anritsu	MP59B	M20531	May 21, 2017
Pulse Limiter	Rohde & Schwarz	ESH3-Z2	100006	May 20, 2017
Voltage Probe	Rohde & Schwarz	TK9416	N/A	May 20, 2017

3.1.2. Radiated Emission Test Equipment

EQUIPMENT TYPE	MFR	MODEL NUMBER	SERIAL NUMBER	LAST CAL.
EMI Test Receiver	Rohde & Schwarz	ESU	1302.6005.26	May 21, 2017
Pre-Amplifier	HP	8447D	2944A07999	May 20, 2017
Bilog Antenna	Schwarzbeck	VULB9163	142	May 20, 2017
Loop Antenna	ARA	PLA-1030/B	1029	May 20, 2017
Horn Antenna	Schwarzbeck	BBHA 9170	BBHA9170399	May 20, 2017
Horn Antenna	Schwarzbeck	BBHA 9120	D143	May 20, 2017
Cable	Schwarzbeck	AK9513	ACRX1	May 21, 2017
Cable	Rosenberger	N/A	FP2RX2	May 21, 2017
Cable	Schwarzbeck	AK9513	CRPX1	May 21, 2017
Cable	Schwarzbeck	AK9513	CRRX2	May 21, 2017

4. CONDUCTED EMISSION MEASUREMENT

4.1. Block Diagram of Test Setup

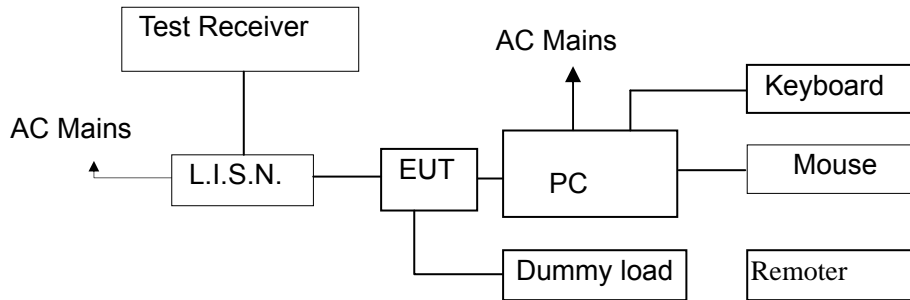

(EUT: LED LCD TV)

4.2. Measuring Standard

FCC Part 15, Subpart B, Class BANSI C63.4: 2014

4.3. Power Line Conducted Emission Limits (Class B)

Frequency (MHz)	Limit (dB μ V)	
	Quasi-peak Level	Average Level
0.15 ~ 0.50	66.0 ~ 56.0 *	56.0 ~ 46.0 *
0.50 ~ 5.00	56.0	46.0
5.00 ~ 30.00	60.0	50.0

NOTE1-The lower limit shall apply at the transition frequencies.
NOTE2-The limit decreases linearly with the logarithm of the frequency in the range 0.15MHz to 0.50MHz.

4.4. EUT Configuration on Measurement

The following equipments are installed on Conducted Emission Measurement to meet FCC requirements and operating in a manner which tends to maximize its emission characteristics in a normal application.

EUT : LED LCD TV
Model Number : LC-43P3000U

4.5. Operating Condition of EUT

4.5.1. Setup the EUT as shown on Section 4.1.

4.5.2. Turn on the power of all equipments.

4.5.3. Let the EUT work in measuring mode (HDMI 1 IN, HDMI 2 IN, HDMI 3 IN) and measure it. (The HDMI Port connect to PC HDMI Port via HDMI line)

4.6. Test Procedure

The EUT is put on the plane 0.8m high above the ground by insulating support and connected to the AC mains through Line Impedance Stability Network (L.I.S.N). This provided a 50ohm coupling impedance for the tested equipments. Both sides of AC line are investigated to find out the maximum conducted emission according to the FCC regulations during conducted emission measurement.

The bandwidth of the field strength meter (R&S Test Receiver ESCS30) is set at 9kHz in 150kHz~30MHz and 200Hz in 9kHz~150kHz.

The frequency range from 150kHz to 30MHz is investigated.

4.7. Measuring Results

PASS.

Please refer to the following pages.

The worst mode is HDMI 1 IN, and the mode is the LED LCD TV connected to PC. Please refer to the following pages.

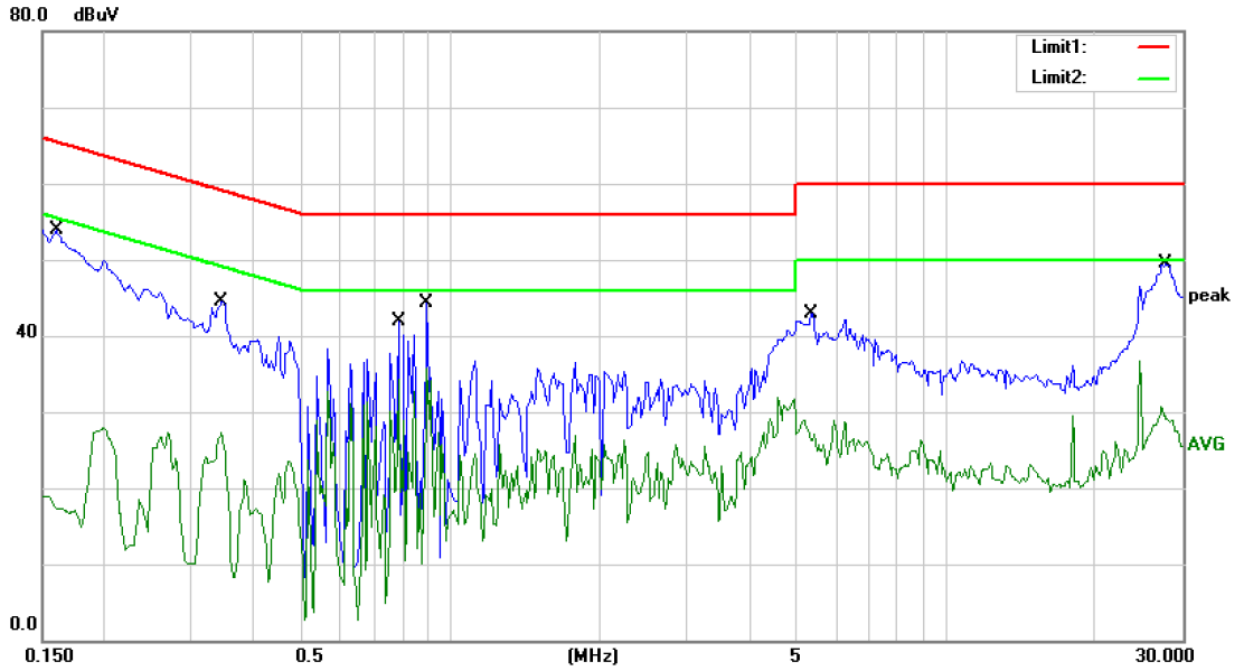

Site Conduction #1 Phase: **L1** Temperature: 22
 Limit: (CE)FCC PART 15 class B_QP Power: AC 120V/60Hz Humidity: 55 %
 Mode: HDMI 1 IN
 Note:

No.	Mk.	Freq.	Reading Level	Correct Factor	Measurement	Limit	Over	Detector	Comment
		MHz	dBuV	dB	dBuV	dBuV	dB		
1		0.1600	53.82	0.00	53.82	65.46	-11.64	QP	
2		0.1600	28.00	0.00	28.00	55.46	-27.46	AVG	
3		0.3450	44.53	0.00	44.53	59.08	-14.55	QP	
4		0.3450	27.26	0.00	27.26	49.08	-21.82	AVG	
5		0.7850	41.82	0.00	41.82	56.00	-14.18	QP	
6		0.7850	34.35	0.00	34.35	46.00	-11.65	AVG	
7		0.8950	44.28	0.00	44.28	56.00	-11.72	QP	
8	*	0.8950	35.62	0.00	35.62	46.00	-10.38	AVG	
9		5.3600	42.85	0.00	42.85	60.00	-17.15	QP	
10		5.3600	31.90	0.00	31.90	50.00	-18.10	AVG	
11		27.7300	49.46	0.00	49.46	60.00	-10.54	QP	
12		27.7300	36.68	0.00	36.68	50.00	-13.32	AVG	

*:Maximum data x:Over limit !:over margin Comment: Factor build in receiver. Operator: Stan

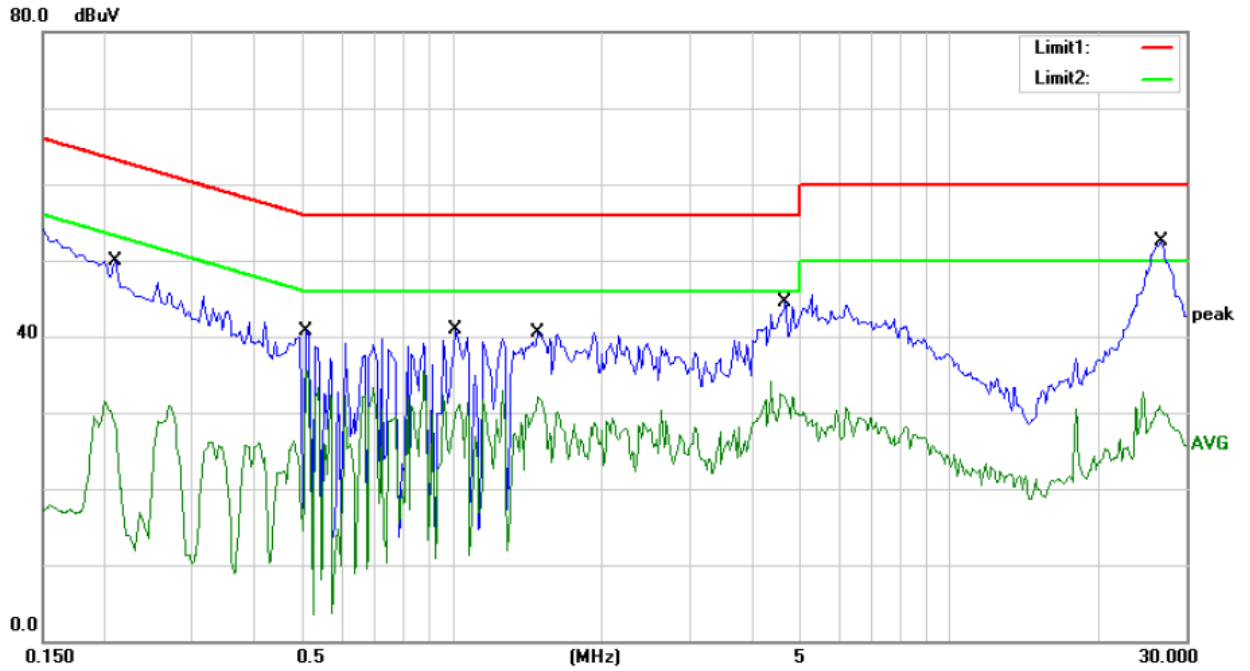

Site Conduction #1
 Limit: (CE)FCC PART 15 class B_QP
 Mode: HDMI 1 IN
 Note:

Phase: **N**
 Power: AC 120V/60Hz

Temperature: 22
 Humidity: 55 %

No. Mk.	Freq. MHz	Reading Level dBuV	Correct Factor dB	Measurement dBuV	Limit dBuV	Over dB	Detector	Comment
1	0.2100	50.00	0.00	50.00	63.21	-13.21	QP	
2	0.2100	31.43	0.00	31.43	53.21	-21.78	AVG	
3	0.5100	40.72	0.00	40.72	56.00	-15.28	QP	
4	0.5100	35.49	0.00	35.49	46.00	-10.51	AVG	
5	1.0150	40.88	0.00	40.88	56.00	-15.12	QP	
6	1.0150	32.23	0.00	32.23	46.00	-13.77	AVG	
7	1.4850	40.44	0.00	40.44	56.00	-15.56	QP	
8	1.4850	33.00	0.00	33.00	46.00	-13.00	AVG	
9	4.6850	44.60	0.00	44.60	56.00	-11.40	QP	
10	4.6850	34.13	0.00	34.13	46.00	-11.87	AVG	
11 *	26.7200	52.45	0.00	52.45	60.00	-7.55	QP	
12	26.7200	32.64	0.00	32.64	50.00	-17.36	AVG	

*:Maximum data x:Over limit !:over margin Comment: Factor build in receiver. Operator: Stan

5. RADIATED EMISSION MEASUREMENT

5.1. Block Diagram of Test Setup

5.1.1. Block diagram of EUT System

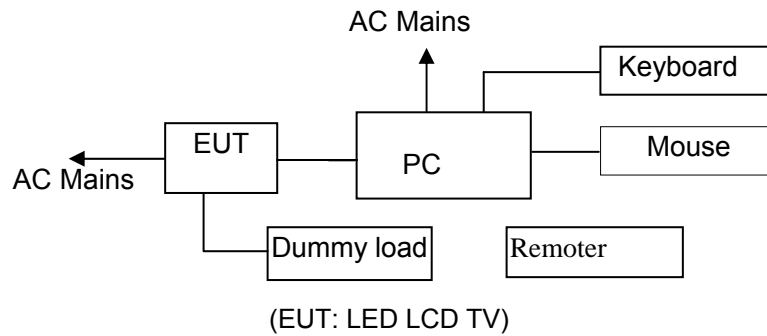

5.1.2. Block diagram of test setup (In chamber)

30MHz-1GHz:

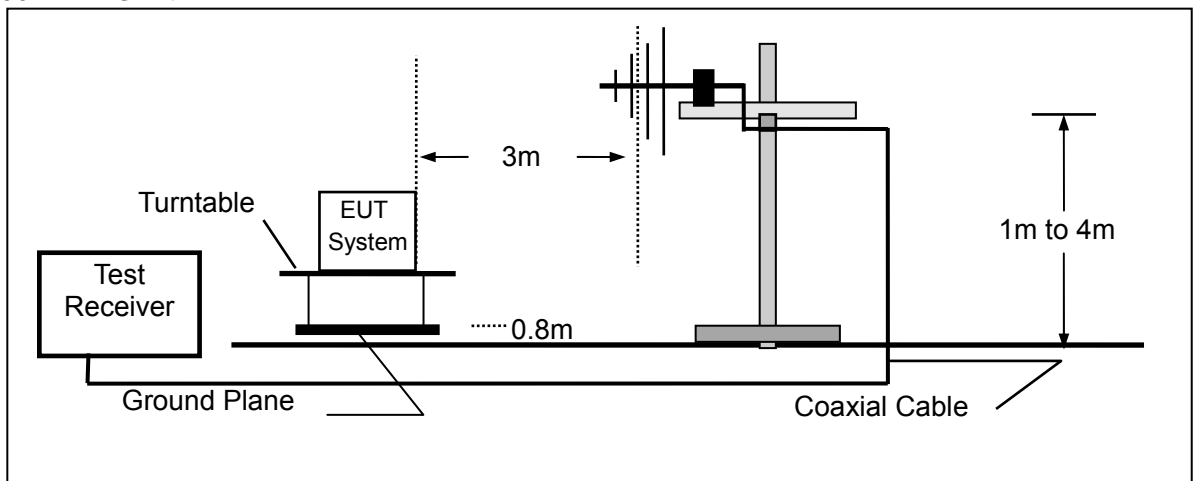

1GHz-6GHz:

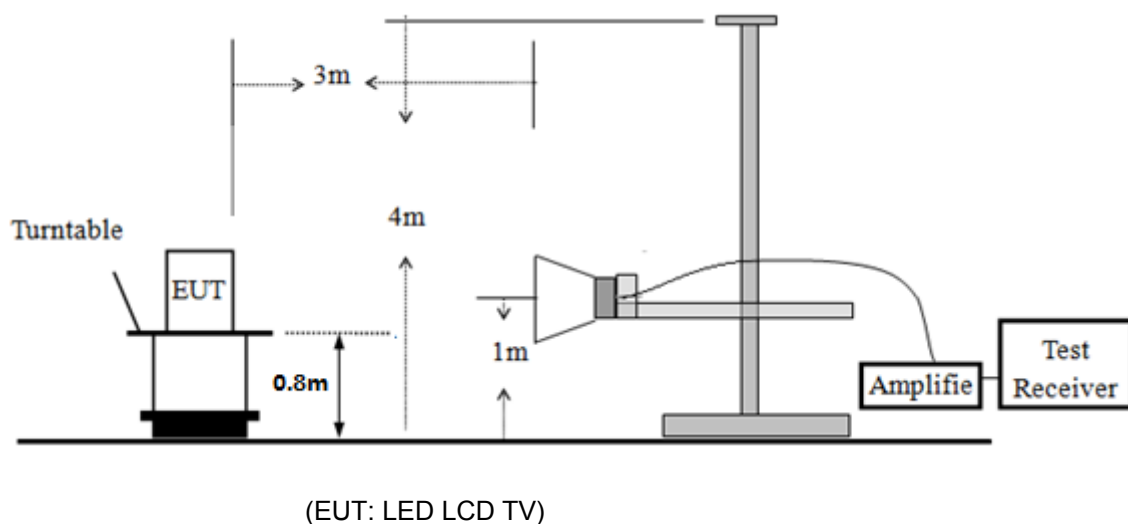

5.2. Measuring Standard

FCC Part 15, Subpart B, Class B ANSI C63.4: 2014

5.3. Radiated Emission Limits (Class B)

Frequency MHz	Distance Meters	Field Strengths Limit	
		$\mu\text{V}/\text{m}$	$\text{dB}(\mu\text{V})/\text{m}@3\text{M}$
30 ~ 88	10	100	40
88 ~ 216	10	150	43.5
216 ~ 960	10	200	46
960 ~ 1000	10	500	54

Frequency (GHz)	Distance (Meters)	Field Strengths Limit	
		Average ($\text{dB}\mu\text{V}/\text{m}$)	Peak ($\text{dB}\mu\text{V}/\text{m}$)
1~6	3	54	74

Remark: (1) Emission level ($\text{dB}\mu\text{V}$) = $20 \log$ Emission level $\mu\text{V}/\text{m}$
 (2) The smaller limit shall apply at the cross point between two frequency bands.
 (3) Distance is the distance in meters between the measuring instrument, antenna and the closest point of any part of the device or system.

5.4. EUT Configuration on Measurement

The FCC Class B regulations test method must be used to find the maximum emission during radiated emission measurement.

EUT : LED LCD TV
 Model Number : LC-43P3000U

5.5. Operating Condition of EUT

5.5.1. Setup the EUT as shown on Section 5.1.

5.5.2. Turn on the power of all equipments.

5.5.3. Let the EUT work in measuring mode (HDMI 1 IN, HDMI 2 IN, HDMI 3 IN) and measure it. (The HDMI Port connect to PC HDMI Port via HDMI line)

5.6. Test Procedure

The EUT is placed on a turn table which is 0.8 meter high above the ground. The turn table can rotate 360 degrees to determine the position of the maximum emission level. The EUT is set 3 meters away from the receiving antenna which is mounted on a antenna tower. The antenna can be moved up and down from 1 to 4 meters to find out the maximum emission level. Bilog antenna (calibrated by Dipole Antenna) is used as a receiving antenna. Both horizontal and vertical polarization of the antenna are set on test.

The bandwidth of the Receiver (ESU26) is set at 120kHz.

5.7. Measuring Results

PASS.

The frequency range from 30MHz to 6000MHz is investigated.

The worst mode is HDMI 2 IN, and the mode is the LED LCD TV connected to PC. Please refer to the following pages.

Please refer to the following pages.

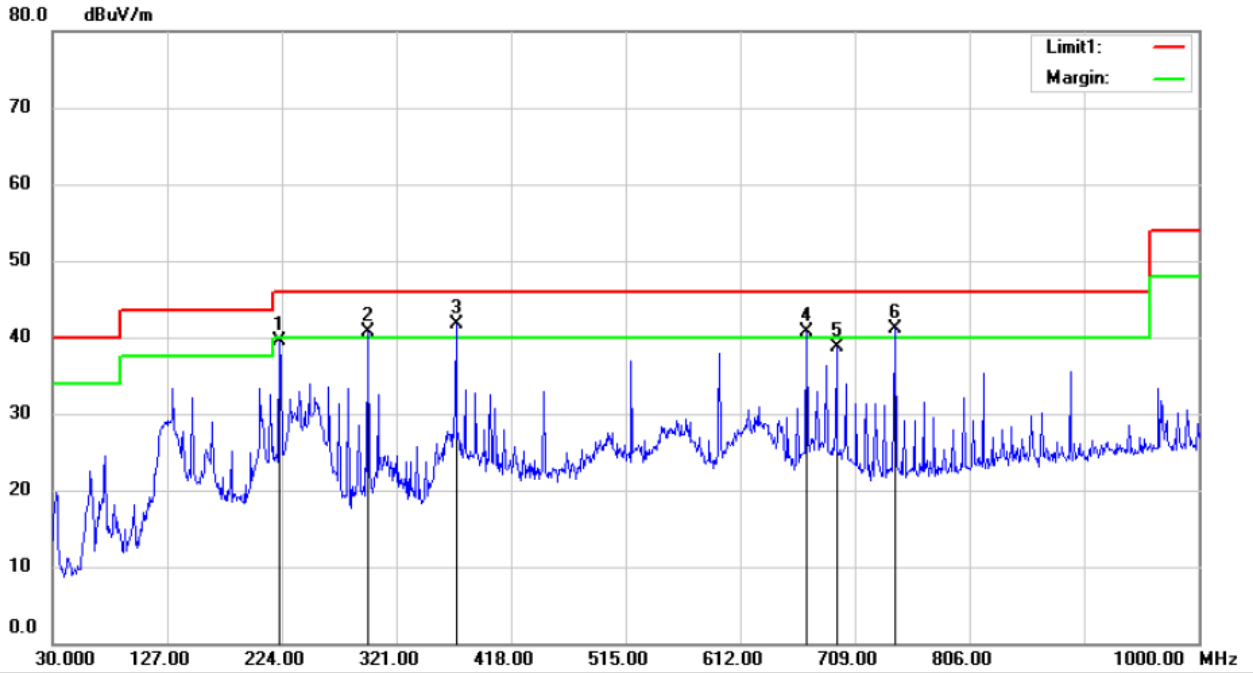

Site 3m Chamber #3

Polarization: **Horizontal**

Temperature: 24 C

Limit: (RE)FCC PART 15 CLASS B

Power: AC 120V/60Hz

Humidity: 53 %

Mode:HDMI 2 IN

Note:

No.	Mk.	Freq. MHz	Reading Level dBuV	Correct Factor dB	Measure- ment dBuV/m	Limit dBuV/m	Over dB	Detector
1		222.0600	54.22	-14.79	39.43	46.00	-6.57	QP
2	!	296.7500	53.35	-12.64	40.71	46.00	-5.29	QP
3	*	371.4400	52.11	-10.47	41.64	46.00	-4.36	QP
4	!	668.2600	45.22	-4.53	40.69	46.00	-5.31	QP
5		693.4800	42.99	-4.26	38.73	46.00	-7.27	QP
6	!	742.9500	44.49	-3.45	41.04	46.00	-4.96	QP

*:Maximum data x:Over limit !:over margin

Operator: CL

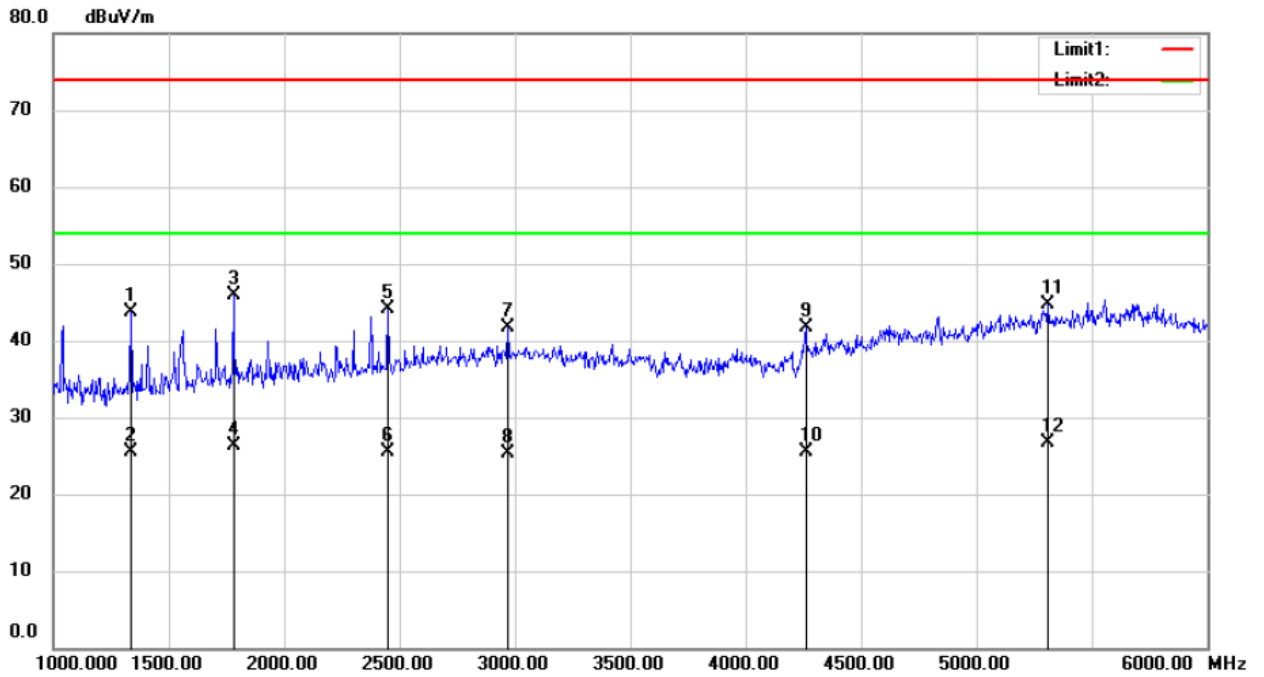

Site 3m Chamber #1

Polarization: **Vertical**

Temperature: 22 C

Limit: (RE)FCC PART 15 CLASS B

Power: AC 120V/60Hz

Humidity: 50 %

Mode:HDMI 2 IN

Note:

No.	Mk.	Freq. MHz	Reading Level dBuV	Correct Factor dB	Measure- ment dBuV/m	Limit dBuV/m	Over dB	Detector
1		1335.000	59.90	-16.27	43.63	74.00	-30.37	peak
2		1335.000	41.77	-16.27	25.50	54.00	-28.50	AVG
3		1780.000	61.33	-15.46	45.87	74.00	-28.13	peak
4		1780.000	41.86	-15.46	26.40	54.00	-27.60	AVG
5		2450.000	57.82	-13.75	44.07	74.00	-29.93	peak
6		2450.000	39.35	-13.75	25.60	54.00	-28.40	AVG
7		2970.000	53.56	-11.91	41.65	74.00	-32.35	peak
8		2970.000	37.21	-11.91	25.30	54.00	-28.70	AVG
9		4260.000	50.33	-8.56	41.77	74.00	-32.23	peak
10		4260.000	34.06	-8.56	25.50	54.00	-28.50	AVG
11		5310.000	50.49	-5.87	44.62	74.00	-29.38	peak
12	*	5310.000	32.57	-5.87	26.70	54.00	-27.30	AVG

*:Maximum data x:Over limit !:over margin

Operator: KK

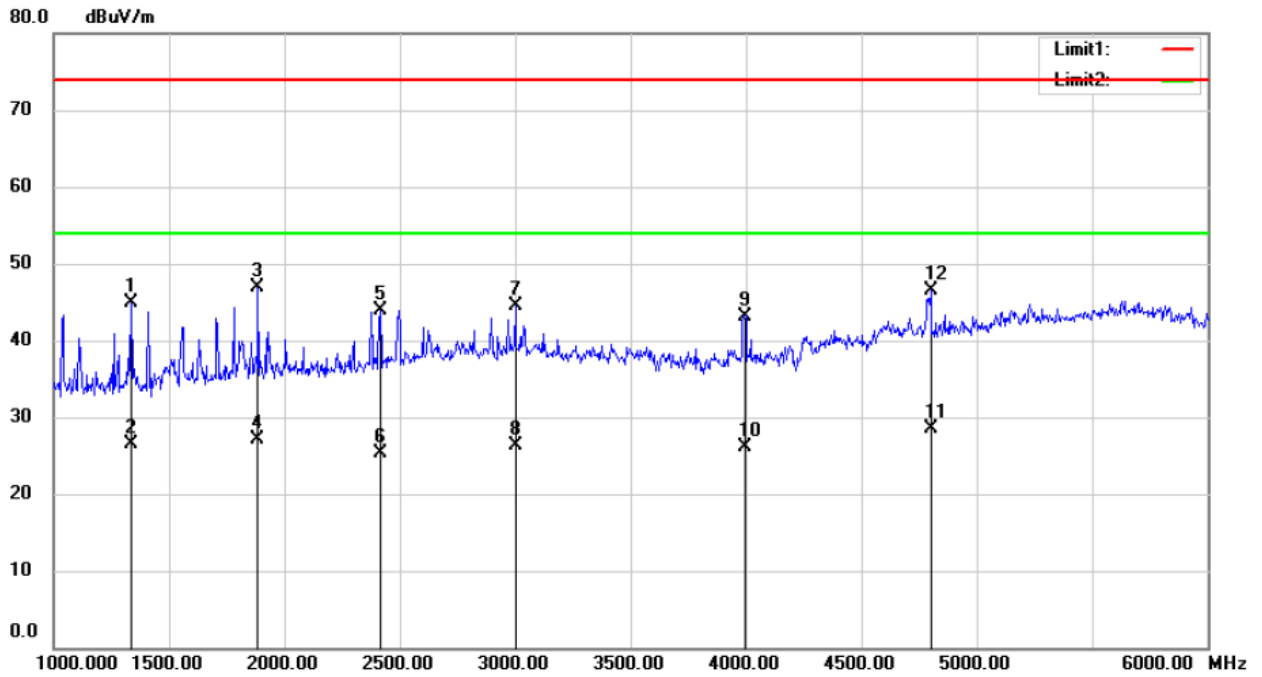

Site 3m Chamber #1 Polarization: **Horizontal** Temperature: 22 C
 Limit: (RE)FCC PART 15 CLASS B Power: AC 120V/60Hz Humidity: 50 %
 Mode:HDMI 2 IN
 Note:

No.	Mk.	Freq. MHz	Reading Level dBuV	Correct Factor dB	Measure- ment dBuV/m	Limit dBuV/m	Over dB	Detector
1		1335.000	61.27	-16.27	45.00	74.00	-29.00	peak
2		1335.000	42.87	-16.27	26.60	54.00	-27.40	AVG
3		1885.000	62.28	-15.33	46.95	74.00	-27.05	peak
4		1885.000	42.43	-15.33	27.10	54.00	-26.90	AVG
5		2415.000	57.80	-13.85	43.95	74.00	-30.05	peak
6		2415.000	39.15	-13.85	25.30	54.00	-28.70	AVG
7		3000.000	56.29	-11.80	44.49	74.00	-29.51	peak
8		3000.000	38.20	-11.80	26.40	54.00	-27.60	AVG
9		3995.000	52.83	-9.63	43.20	74.00	-30.80	peak
10		3995.000	35.83	-9.63	26.20	54.00	-27.80	AVG
11		4800.000	35.69	-7.19	28.50	74.00	-45.50	peak
12	*	4800.000	53.70	-7.19	46.51	54.00	-7.49	AVG

*:Maximum data x:Over limit !:over margin

Operator: KK

Detail of factor for radiated emission

Frequency(MHz)	Ant_F(dB)	Cab_L(dB)	Preamp(dB)	Correct Factor(dB)
0.009	20.6	0.03	\	20.63
0.15	20.7	0.1	\	20.8
1	20.9	0.15	\	21.05
10	20.1	0.28	\	20.38
30	18.8	0.45	\	19.25
30	11.7	0.62	27.9	-15.58
100	12.5	1.02	27.8	-14.28
300	12.9	1.91	27.5	-12.69
600	19.2	2.92	27	-4.88
800	21.1	3.54	26.6	-1.96
1000	22.3	4.17	26.2	0.27
1000	25.6	1.76	41.4	-14.04
3000	28.9	3.27	43.2	-11.03
5000	31.1	4.2	44.6	-9.3
8000	36.2	5.95	44.7	-2.55
10000	38.4	6.3	43.9	0.8
12000	38.5	7.14	42.3	3.34
15000	40.2	8.15	41.4	6.95
18000	45.4	9.02	41.3	13.12
18000	37.9	1.81	47.9	-8.19
21000	37.9	1.95	48.7	-8.85
25000	39.3	2.01	42.8	-1.49
28000	39.6	2.16	46.0	-4.24
31000	41.2	2.24	44.5	-1.06
34000	41.5	2.29	46.6	-2.81
37000	43.8	2.30	46.4	-0.3
40000	43.2	2.50	42.2	3.5

-----The end-----