

FCC 47 CFR PART 15 SUBPART B
CERTIFICATION TEST REPORT

Hisense Electric Co., Ltd.

LED LCD TV

Model No.: 43H3507, 43H3D, 43H3D+, 43H3C, 43H320D, 43H330D, 43H350D,
43H360D, 43H3020D, 43H3030D, 43H3050D, 43H3060D

FCC ID:W9HLCDD0074

Trademark: HISENSE

Prepared for : Hisense Electric Co., Ltd.
Address : No. 218 Qianwangang Road, Economy & Technology
Development Zone, Qingdao 266071

Prepared by : EMTEK(SHENZHEN) CO., LTD.
Address : Bldg 69, Majialong Industry Zone,
Nanshan District, Shenzhen, Guangdong, China

Tel: (0755) 26954280

Fax: (0755) 26954282

Report Number : ES170203006E
Date of Test : February 03, 2017 to February 13, 2017
Date of Report : February 13, 2017

TABLE OF CONTENT

Test Report Description	Page
1. SUMMARY OF TEST RESULT	5
2. GENERAL INFORMATION	6
2.1. DESCRIPTION OF DEVICE (EUT).....	6
2.2. DESCRIPTION OF SUPPORT DEVICE	6
2.3. DESCRIPTION OF TEST FACILITY	7
2.4. MEASUREMENT UNCERTAINTY	7
3. MEASURING DEVICE AND TEST EQUIPMENT.....	8
3.1. FOR POWER LINE CONDUCTED EMISSION MEASUREMENT	8
3.2. FOR RADIATED EMISSION MEASUREMENT	8
4. POWER LINE CONDUCTED EMISSION MEASUREMENT	9
4.1. BLOCK DIAGRAM OF TEST SETUP.....	9
4.2. MEASURING STANDARD	9
4.3. POWER LINE CONDUCTED EMISSION LIMITS (CLASS B).....	9
4.4. EUT CONFIGURATION ON MEASUREMENT	9
4.5. OPERATING CONDITION OF EUT	10
4.6. TEST PROCEDURE.....	11
4.7. MEASURING RESULTS	11
5. RADIATED EMISSION MEASUREMENT	18
5.1. BLOCK DIAGRAM OF TEST SETUP.....	18
5.2. MEASURING STANDARD	18
5.3. RADIATED EMISSION LIMITS (CLASS B).....	18
5.4. EUT CONFIGURATION ON MEASUREMENT	19
5.5. OPERATING CONDITION OF EUT	19
5.6. TEST PROCEDURE.....	19
5.7. MEASURING RESULTS	19

TEST REPORT DESCRIPTION

APPLICANT : Hisense Electric Co., Ltd.
No. 218 Qianwangang Road, Economy & Technology Development
Zone, Qingdao 266071

MANUFACTURER : Hisense Electric Co., Ltd.
No. 218 Qianwangang Road, Economy & Technology Development
Zone, Qingdao 266071

FACTORY 1 : Guangdong Hisense Electronics Co., Ltd
Zone B, No. 8 Hisense Road, Advanced Manufacturing Jiangsha
Demonstration Park, Jiangmen City, Guangdong Province, PRC

FACTORY 2 : HISENSE ELECTRONICA MEXICO, S.A. DE C.V.
Blvd. Sharp #3510 Parque Industrial Rosarito, C.P. 22710 Playas de
Rosarito, Baja California, Mexico

Trade Mark : HISENSE

EUT : LED LCD TV

Model No. : 43H3507, 43H3D, 43H3D+, 43H3C, 43H320D, 43H330D, 43H350D,
43H360D, 43H3020D, 43H3030D, 43H3050D, 43H3060D

Power Supply : AC 120V / 60Hz

Measurement Procedure Used:

FCC Rules and Regulations Part 15: 2015 Subpart B Class B & FCC / ANSI C63.4-2014

The device described above is tested by EMTEK(SHENZHEN) CO., LTD. to determine the maximum emission levels emanating from the device and the severe levels of the device can endure and its performance criterion. The measurement results are contained in this test report and EMTEK(SHENZHEN) CO., LTD. is assumed full of responsibility for the accuracy and completeness of these measurements. Also, this report shows that the EUT (Equipment Under Test) is technically compliant with the FCC requirements.

This report applies to above tested sample only and shall not be reproduced in part without written approval of EMTEK(SHENZHEN) CO., LTD.

Date of Test : February 03, 2017 to February 13, 2017

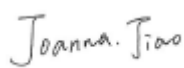
Prepared by : 
Joanna Jiao/Editor

Reviewer : 
Joe Xia/Supervisor

Approved & Authorized Signer : 
Lisa Wang/Manager

Modified Information

Version	Report No.	Revision Data	Summary
Ver.1.0	ES170203006E	/	Original Version

1. SUMMARY OF TEST RESULT

EMISSION		
Description of Test Item	Standard & Limits	Results
Conducted Disturbance at Mains Terminals	FCC Part 15, Subpart B, Class B ANSI C63.4: 2014	Pass
Radiated Disturbance	FCC Part 15, Subpart B, Class B ANSI C63.4: 2014	Pass
Note: N/A is an abbreviation for Not Applicable.		

2. GENERAL INFORMATION

2.1. Description of Device (EUT)

EUT	:	LED LCD TV
Model Number	:	43H3507, 43H3D, 43H3D+, 43H3C, 43H320D, 43H330D, 43H350D, 43H360D, 43H3020D, 43H3030D, 43H3050D, 43H3060D (Note: These models are identical in circuitry and electrical, mechanical and physical construction; the only difference is appearance design and model name. We prepare 43H3507 for test, and the worst result recorded in the report.)
Applicant Address	:	Hisense Electric Co., Ltd. No. 218 Qianwangang Road, Economy&Technology Development Zone, Qingdao 266071
Manufacturer Address	:	Hisense Electric Co., Ltd. No. 218 Qianwangang Road, Economy&Technology Development Zone, Qingdao 266071
FACTORY 1	:	Guangdong Hisense Electronics Co., Ltd Zone B, No. 8 Hisense Road, Advanced Manufacturing Jiangsha Demonstration Park, Jiangmen City, Guangdong Province, PRC
FACTORY 2	:	HISENSE ELECTRONICA MEXICO, S.A. DE C.V. Blvd. Sharp #3510 Parque Industrial Rosarito, C.P. 22710 Playas de Rosarito, Baja California, Mexico
Date of Received	:	February 03, 2017
Date of Test	:	February 03, 2017 to February 13, 2017

2.2. Description of Support Device

PC	:	Manufacturer: Lenovo M/N: ThinkCentre 8701 S/N: 8701A53L3BC108 CE, FCC
Keyboard	:	Manufacturer: Lenovo M/N: KB-0225 S/N: 41A5039
Mouse	:	Manufacturer: Lenovo M/N: MO28UOL S/N: 44D2639
Dummy Load	:	Manufacturer: Cultraview M/N: CVNS1200

Description of Cable

Cables			
No.	Type	Length	Remark
1.	Power Cable	1.5 m	Unshielded
2.	HDMI Cable*3	0.8 m	Unshielded
3.	AV Cable	1.0 m	Unshielded

2.3. Description of Test Facility

Site Description

EMC Lab. : Accredited by CNAS, 2016.10.24
 The certificate is valid until 2022.10.28
 The Laboratory has been assessed and proved to be in compliance with CNAS-CL01:2006 (identical to ISO/IEC 17025:2005)
 The Certificate Registration Number is L2291.

Name of Firm : EMTEK(SHENZHEN) CO., LTD.
 Site Location : Bldg 69, Majialong Industry Zone,
 Nanshan District, Shenzhen, Guangdong, China

2.4. Measurement Uncertainty

Test Item	Uncertainty
Conducted Emission Uncertainty	: 3.16dB(9k~150kHz Conduction 2#) 2.90dB(150k-30MHz Conduction 2#)
Radiated Emission Uncertainty (3m Chamber)	: 3.78dB (30M~1GHz Polarize: H) 4.27dB (30M~1GHz Polarize: V) 4.46dB (1~6GHz)

3. MEASURING DEVICE AND TEST EQUIPMENT

3.1. For Power Line Conducted Emission Measurement

Used	Equipment	Manufacturer	Model No.	Serial No.	Last Cal.	Cal. Interval
<input checked="" type="checkbox"/>	L.I.S.N.	ROHDE & SCHWARZ	ESH3-Z6	100011	May 28, 2016	1 Year
<input checked="" type="checkbox"/>	L.I.S.N.	ROHDE & SCHWARZ	ESH3-Z6	100253	May 28, 2016	1 Year
<input checked="" type="checkbox"/>	50Ω Coaxial Switch	Anritsu	MP59B	M20531	May 28, 2016	1 Year
<input checked="" type="checkbox"/>	Pulse Limiter	Rohde & Schwarz	ESH3-Z2	100006	May 28, 2016	1 Year

3.2. For Radiated Emission Measurement

Used	Equipment	Manufacturer	Model No.	Serial No.	Last Cal.	Cal. Interval
<input checked="" type="checkbox"/>	EMI Test Receiver	Rohde & Schwarz	ESU	1302.6005.26	May 28, 2016	1 Year
<input checked="" type="checkbox"/>	Pre-Amplifier	HP	8447D	2944A07999	May 28, 2016	1 Year
<input checked="" type="checkbox"/>	Bilog Antenna	Schwarzbeck	VULB9163	142	May 28, 2016	1 Year
<input type="checkbox"/>	Loop Antenna	Schwarzbeck	FMZB 1519	012	May 28, 2016	1 Year
<input type="checkbox"/>	Horn Antenna	Schwarzbeck	BBHA 9170	BBHA9170399	May 28, 2016	1 Year
<input type="checkbox"/>	Horn Antenna	Schwarzbeck	BBHA 9120	D143	May 28, 2016	1 Year
<input checked="" type="checkbox"/>	Cable	Schwarzbeck	AK9513	ACRX1	May 28, 2016	1 Year
<input checked="" type="checkbox"/>	Cable	Rosenberger	N/A	FP2RX2	May 28, 2016	1 Year
<input checked="" type="checkbox"/>	Cable	Schwarzbeck	AK9513	CRPX1	May 28, 2016	1 Year
<input checked="" type="checkbox"/>	Cable	Schwarzbeck	AK9513	CRRX2	May 28, 2016	1 Year
<input type="checkbox"/>	Pre-Amplifier	A.H.	PAM-0126	1415261	May 28, 2016	1 Year

4. POWER LINE CONDUCTED EMISSION MEASUREMENT

4.1. Block Diagram of Test Setup

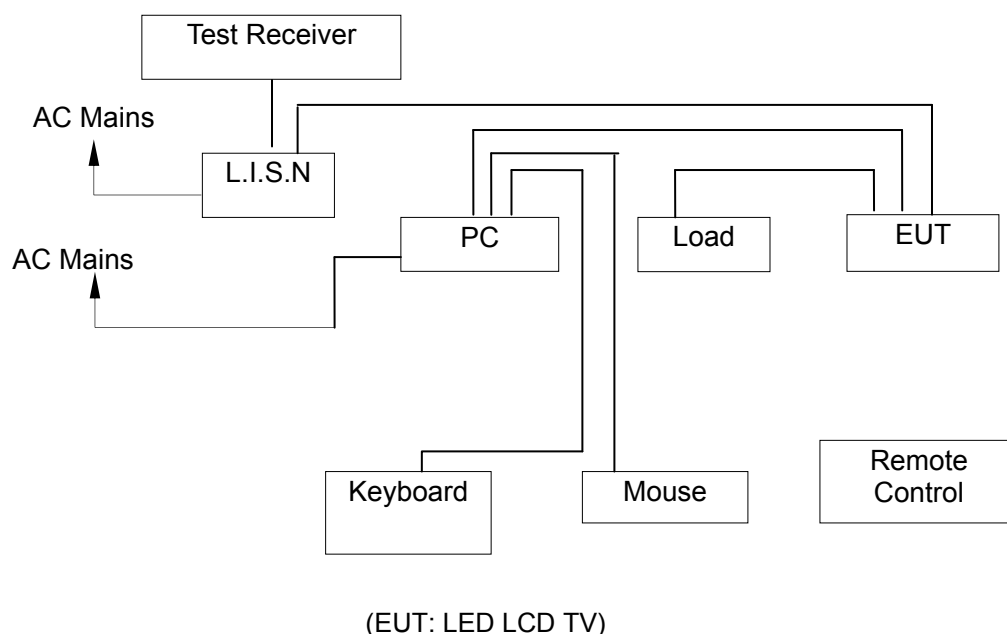

4.2. Measuring Standard

FCC Part 15, Subpart B, Class B ANSI C63.4: 2014

4.3. Power Line Conducted Emission Limits (Class B)

Frequency (MHz)	Limit (dB μ V)	
	Quasi-peak Level	Average Level
0.15 ~ 0.50	66.0 ~ 56.0 *	56.0 ~ 46.0 *
0.50 ~ 5.00	56.0	46.0
5.00 ~ 30.00	60.0	50.0

NOTE1-The lower limit shall apply at the transition frequencies.
NOTE2-The limit decreases linearly with the logarithm of the frequency in the range 0.15MHz to 0.50MHz.

4.4. EUT Configuration on Measurement

The following equipments are installed on Conducted Emission Measurement to meet FCC requirements and operating in a manner which tends to maximize its emission characteristics in a normal application.

EUT : LED LCD TV
Model Number : 43H3507

4.5. Operating Condition of EUT

4.5.1. Setup the EUT as shown on Section 4.1.

4.5.2. Turn on the power of all equipments.

4.5.3. Let the EUT work in measuring mode (HDMI IN1 ARC, HDMI IN 2, HDMI IN 3(PC))measure it.

4.6. Test Procedure

The EUT is put on the plane 0.8m high above the ground by insulating support and connected to the AC mains through Line Impedance Stability Network (L.I.S.N). This provided a 50ohm coupling impedance for the tested equipments. Both sides of AC line are investigated to find out the maximum conducted emission according to the FCC regulations during conducted emission measurement.

The bandwidth of the field strength meter (R&S Test Receiver ESCS30) is set at 9kHz in 150kHz~30MHz and 200Hz in 9kHz~150kHz.

The frequency range from 150kHz to 30MHz is investigated.
All the scanning waveform is put in the following pages.

4.7. Measuring Results

PASS.

Please refer to following pages.

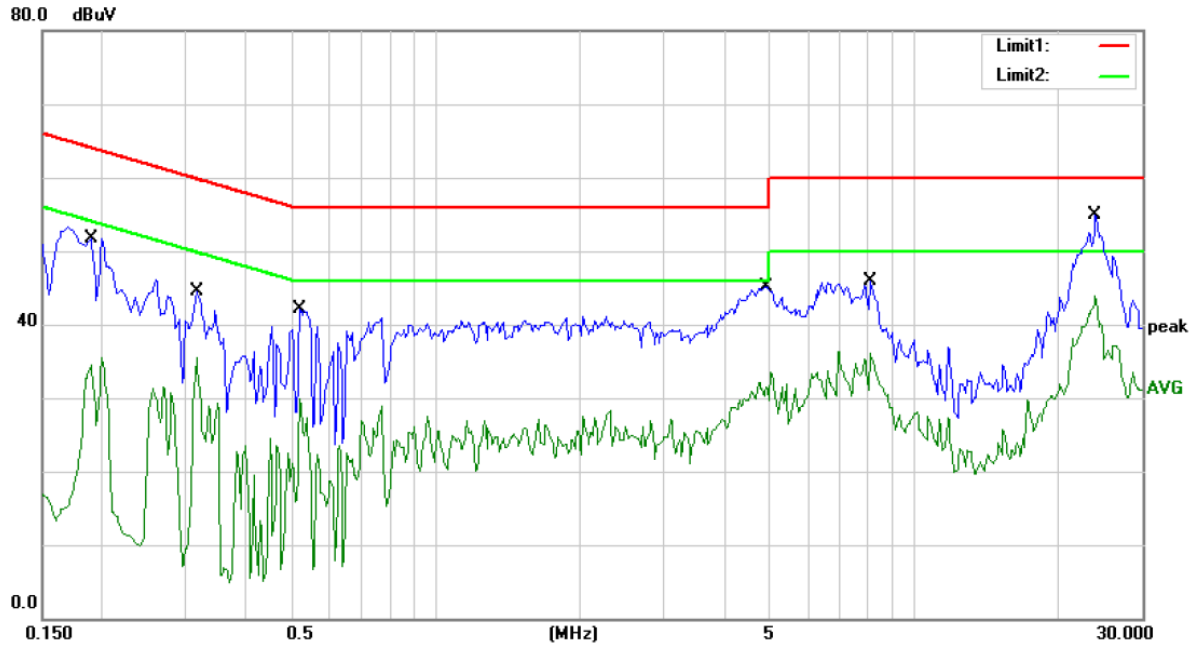

Site Conduction #1 Phase: **N** Temperature: 22
 Limit: (CE)FCC PART 15 class B_QP Power: AC 120V/60Hz Humidity: 55 %
 Mode: HDMI1
 Note:

No.	Mk.	Freq.	Reading Level	Correct Factor	Measurement	Limit	Over	Detector	Comment
		MHz	dBuV	dB	dBuV	dBuV	dB		
1		0.1900	51.80	0.00	51.80	64.04	-12.24	QP	
2		0.1900	35.53	0.00	35.53	54.04	-18.51	AVG	
3		0.3150	44.55	0.00	44.55	59.84	-15.29	QP	
4		0.3150	35.52	0.00	35.52	49.84	-14.32	AVG	
5		0.5200	42.15	0.00	42.15	56.00	-13.85	QP	
6		0.5200	29.90	0.00	29.90	46.00	-16.10	AVG	
7		4.9200	45.09	0.00	45.09	56.00	-10.91	QP	
8		4.9200	33.43	0.00	33.43	46.00	-12.57	AVG	
9		8.1000	45.99	0.00	45.99	60.00	-14.01	QP	
10		8.1000	36.06	0.00	36.06	50.00	-13.94	AVG	
11	*	23.9750	55.00	0.00	55.00	60.00	-5.00	QP	
12		23.9750	43.95	0.00	43.95	50.00	-6.05	AVG	

*:Maximum data x:Over limit !:over margin Comment: Factor build in receiver. Operator: Stan

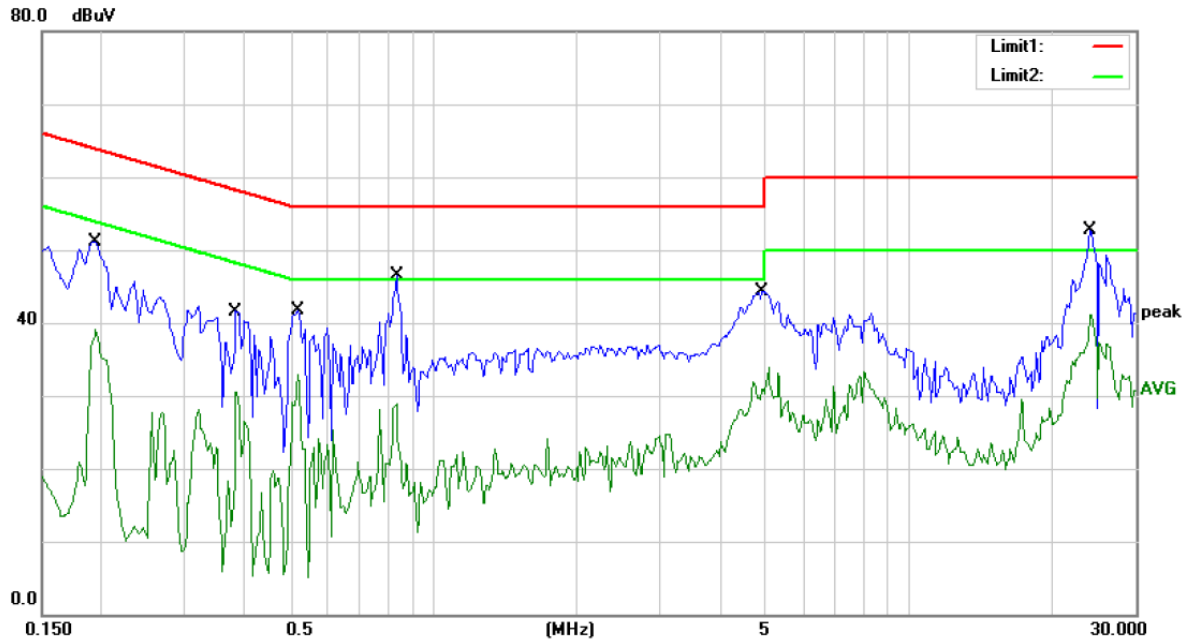

Site Conduction #1 Phase: **L1** Temperature: 22
 Limit: (CE)FCC PART 15 class B_QP Power: AC 120V/60Hz Humidity: 55 %
 Mode: HDMI1
 Note:

No.	Mk.	Freq.	Reading Level	Correct Factor	Measurement	Limit	Over	Detector	Comment
		MHz	dBuV	dB	dBuV	dBuV	dB		
1		0.1950	51.07	0.00	51.07	63.82	-12.75	QP	
2		0.1950	39.18	0.00	39.18	53.82	-14.64	AVG	
3		0.3850	41.60	0.00	41.60	58.17	-16.57	QP	
4		0.3850	30.51	0.00	30.51	48.17	-17.66	AVG	
5		0.5200	41.75	0.00	41.75	56.00	-14.25	QP	
6		0.5200	32.84	0.00	32.84	46.00	-13.16	AVG	
7		0.8350	46.51	0.00	46.51	56.00	-9.49	QP	
8		0.8350	28.98	0.00	28.98	46.00	-17.02	AVG	
9		4.9250	44.27	0.00	44.27	56.00	-11.73	QP	
10		4.9250	33.88	0.00	33.88	46.00	-12.12	AVG	
11	*	24.1000	52.72	0.00	52.72	60.00	-7.28	QP	
12		24.1000	41.19	0.00	41.19	50.00	-8.81	AVG	

*:Maximum data x:Over limit !:over margin Comment: Factor build in receiver. Operator: Stan

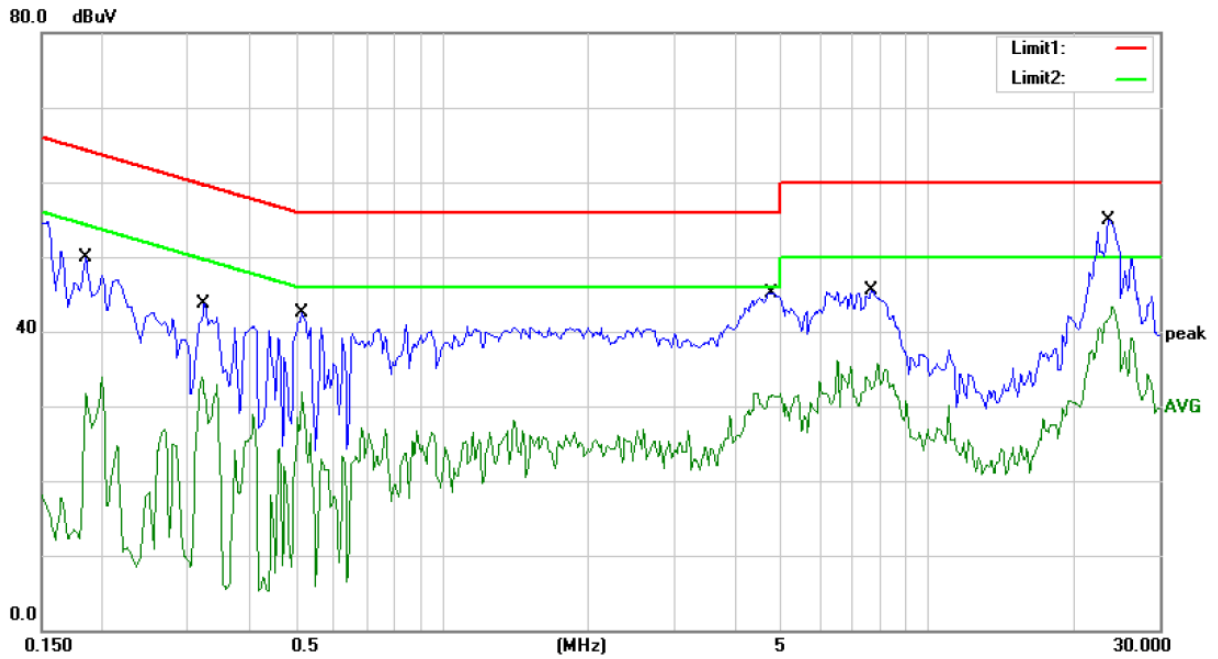

Site Conduction #1 Phase: **N** Temperature: 22
 Limit: (CE)FCC PART 15 class B_QP Power: AC 120V/60Hz Humidity: 55 %
 Mode: HDMI2
 Note:

No. Mk.	Freq.	Reading Level	Correct Factor	Measurement	Limit	Over	Detector	Comment
	MHz	dBuV	dB	dBuV	dBuV	dB		
1	0.1850	49.86	0.00	49.86	64.26	-14.40	QP	
2	0.1850	33.93	0.00	33.93	54.26	-20.33	AVG	
3	0.3250	43.67	0.00	43.67	59.58	-15.91	QP	
4	0.3250	33.98	0.00	33.98	49.58	-15.60	AVG	
5	0.5150	42.51	0.00	42.51	56.00	-13.49	QP	
6	0.5150	31.83	0.00	31.83	46.00	-14.17	AVG	
7	4.7950	45.16	0.00	45.16	56.00	-10.84	QP	
8	4.7950	31.75	0.00	31.75	46.00	-14.25	AVG	
9	7.6700	45.46	0.00	45.46	60.00	-14.54	QP	
10	7.6700	35.63	0.00	35.63	50.00	-14.37	AVG	
11 *	23.5750	54.99	0.00	54.99	60.00	-5.01	QP	
12	23.5750	43.36	0.00	43.36	50.00	-6.64	AVG	

*:Maximum data x:Over limit !:over margin Comment: Factor build in receiver. Operator: Stan

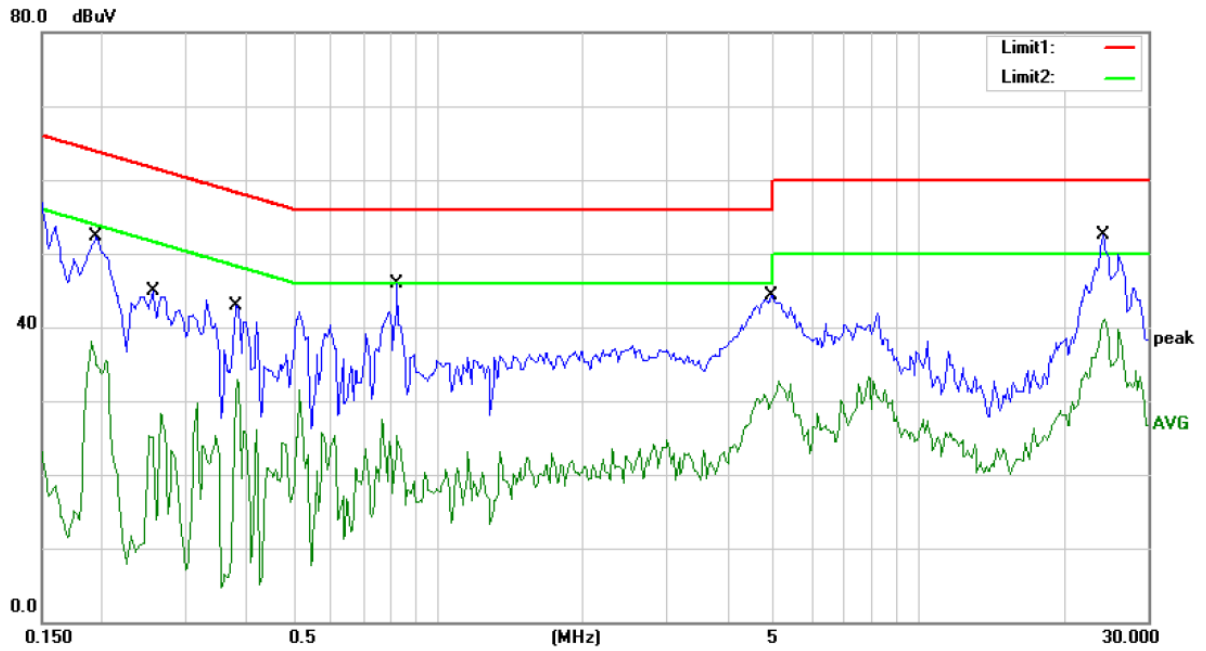

Site Conduction #1

Phase: **L1**

Temperature: 22

Limit: (CE)FCC PART 15 class B_QP

Power: AC 120V/60Hz

Humidity: 55 %

Mode: HDMI2

Note:

No.	Mk.	Freq.	Reading Level	Correct Factor	Measurement	Limit	Over	Detector	Comment
		MHz	dBuV	dB	dBuV	dBuV	dB		
1		0.1950	52.25	0.00	52.25	63.82	-11.57	QP	
2		0.1950	38.14	0.00	38.14	53.82	-15.68	AVG	
3		0.2550	44.88	0.00	44.88	61.59	-16.71	QP	
4		0.2550	28.38	0.00	28.38	51.59	-23.21	AVG	
5		0.3850	43.00	0.00	43.00	58.17	-15.17	QP	
6		0.3850	32.87	0.00	32.87	48.17	-15.30	AVG	
7		0.8250	45.81	0.00	45.81	56.00	-10.19	QP	
8		0.8250	27.49	0.00	27.49	46.00	-18.51	AVG	
9		4.9500	44.33	0.00	44.33	56.00	-11.67	QP	
10		4.9500	32.62	0.00	32.62	46.00	-13.38	AVG	
11	*	24.1750	52.44	0.00	52.44	60.00	-7.56	QP	
12		24.1750	41.10	0.00	41.10	50.00	-8.90	AVG	

*:Maximum data x:Over limit !:over margin Comment: Factor build in receiver. Operator: Stan

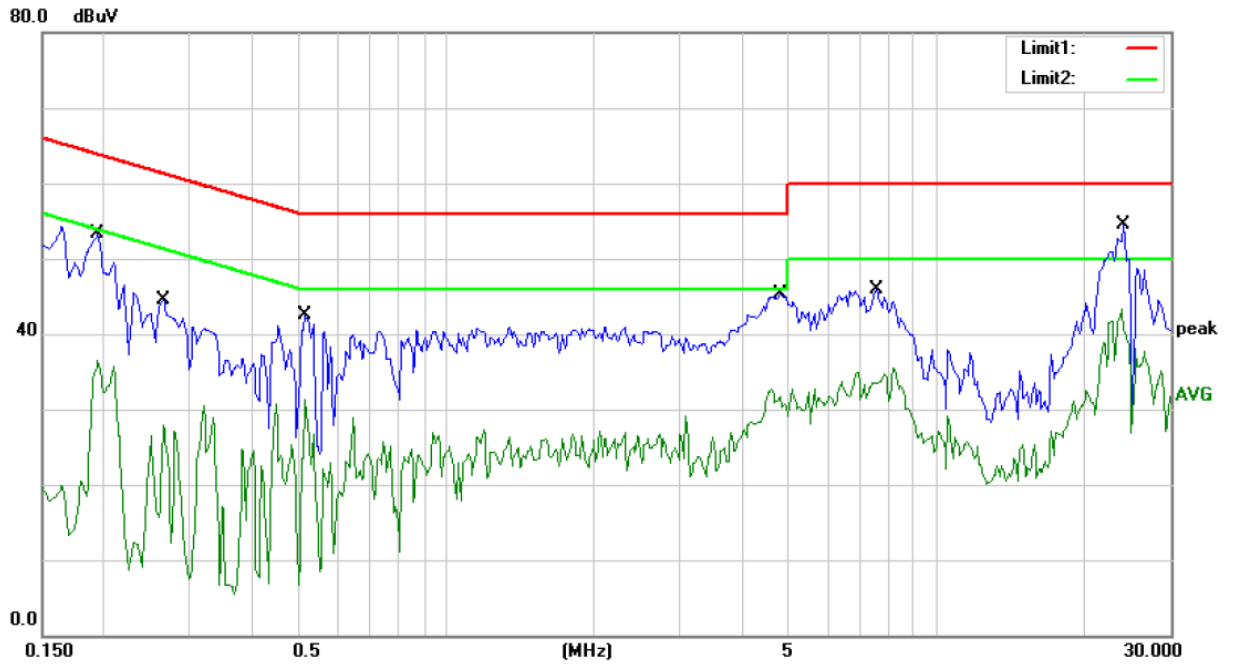

Site Conduction #1 Phase: **N** Temperature: 22
 Limit: (CE)FCC PART 15 class B_QP Power: AC 120V/60Hz Humidity: 55 %
 Mode: HDMI3
 Note:

No.	Mk.	Freq.	Reading Level	Correct Factor	Measurement	Limit	Over	Detector	Comment
		MHz	dBuV	dB	dBuV	dBuV	dB		
1		0.1950	53.21	0.00	53.21	63.82	-10.61	QP	
2		0.1950	36.45	0.00	36.45	53.82	-17.37	AVG	
3		0.2650	44.56	0.00	44.56	61.27	-16.71	QP	
4		0.2650	27.99	0.00	27.99	51.27	-23.28	AVG	
5		0.5150	42.41	0.00	42.41	56.00	-13.59	QP	
6		0.5150	31.32	0.00	31.32	46.00	-14.68	AVG	
7		4.8200	45.30	0.00	45.30	56.00	-10.70	QP	
8		4.8200	32.67	0.00	32.67	46.00	-13.33	AVG	
9		7.5300	46.00	0.00	46.00	60.00	-14.00	QP	
10		7.5300	35.59	0.00	35.59	50.00	-14.41	AVG	
11	*	24.0500	54.52	0.00	54.52	60.00	-5.48	QP	
12		24.0500	43.25	0.00	43.25	50.00	-6.75	AVG	

*:Maximum data x:Over limit !:over margin Comment: Factor build in receiver. Operator: Stan

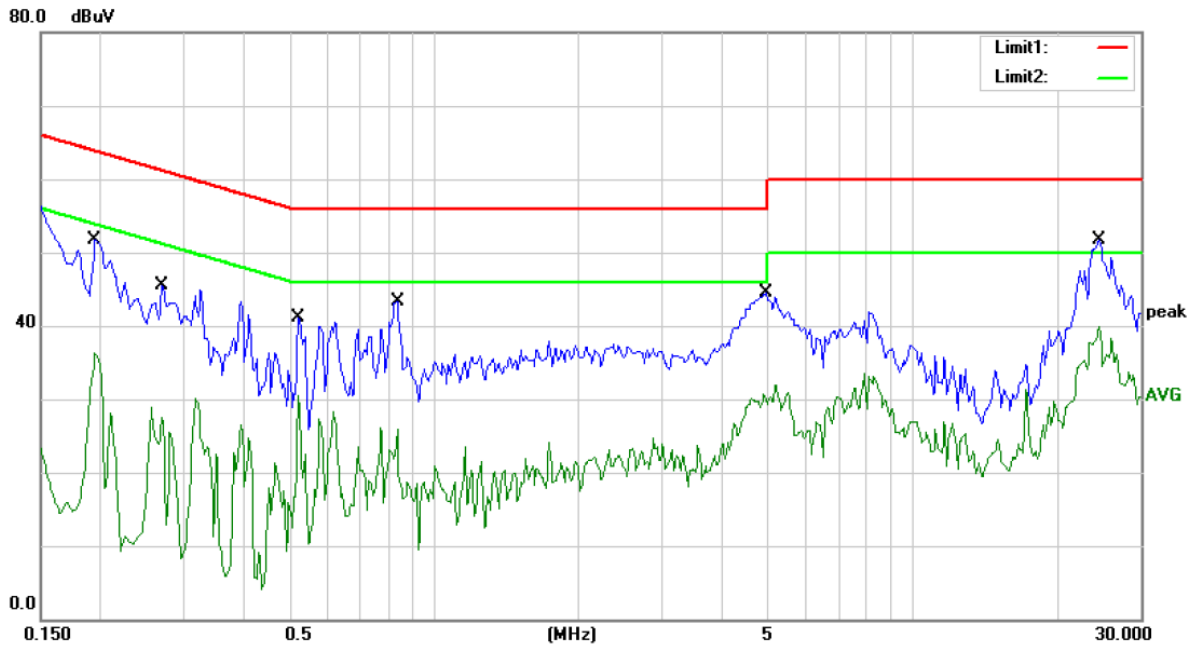

Site Conduction #1 Phase: **L1** Temperature: 22
 Limit: (CE)FCC PART 15 class B_QP Power: AC 120V/60Hz Humidity: 55 %
 Mode: HDMI3
 Note:

No.	Mk.	Freq.	Reading Level	Correct Factor	Measurement	Limit	Over	Detector	Comment
		MHz	dBuV	dB	dBuV	dBuV	dB		
1		0.1950	51.79	0.00	51.79	63.82	-12.03	QP	
2		0.1950	36.23	0.00	36.23	53.82	-17.59	AVG	
3		0.2700	45.41	0.00	45.41	61.12	-15.71	QP	
4		0.2700	28.87	0.00	28.87	51.12	-22.25	AVG	
5		0.5200	41.15	0.00	41.15	56.00	-14.85	QP	
6		0.5200	30.57	0.00	30.57	46.00	-15.43	AVG	
7		0.8350	43.39	0.00	43.39	56.00	-12.61	QP	
8		0.8350	26.09	0.00	26.09	46.00	-19.91	AVG	
9		4.9300	44.43	0.00	44.43	56.00	-11.57	QP	
10		4.9300	31.95	0.00	31.95	46.00	-14.05	AVG	
11	*	24.6000	51.63	0.00	51.63	60.00	-8.37	QP	
12		24.6000	39.94	0.00	39.94	50.00	-10.06	AVG	

*:Maximum data x:Over limit !:over margin Comment: Factor build in receiver. Operator: Stan

5. RADIATED EMISSION MEASUREMENT

5.1. Block Diagram of Test Setup

5.1.1. Block diagram of EUT System

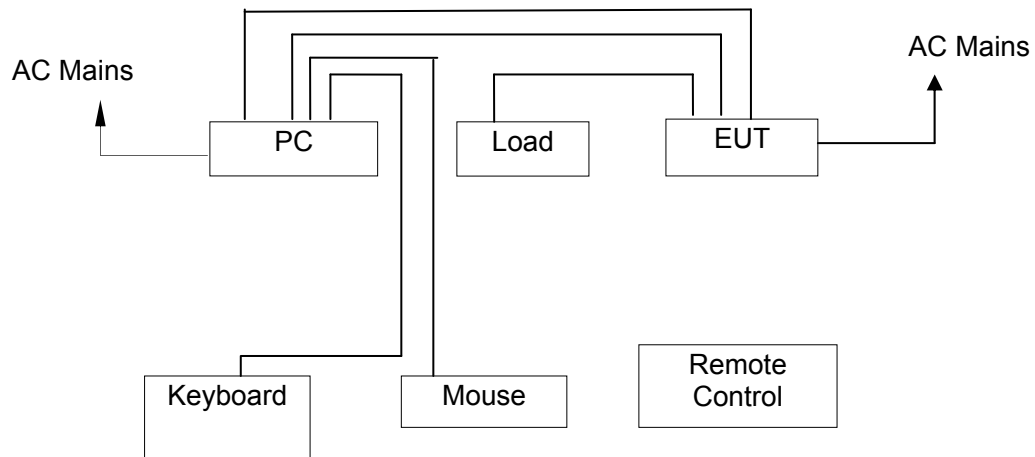

(EUT: LED LCD TV)

5.1.2. Block diagram of test setup (In chamber)

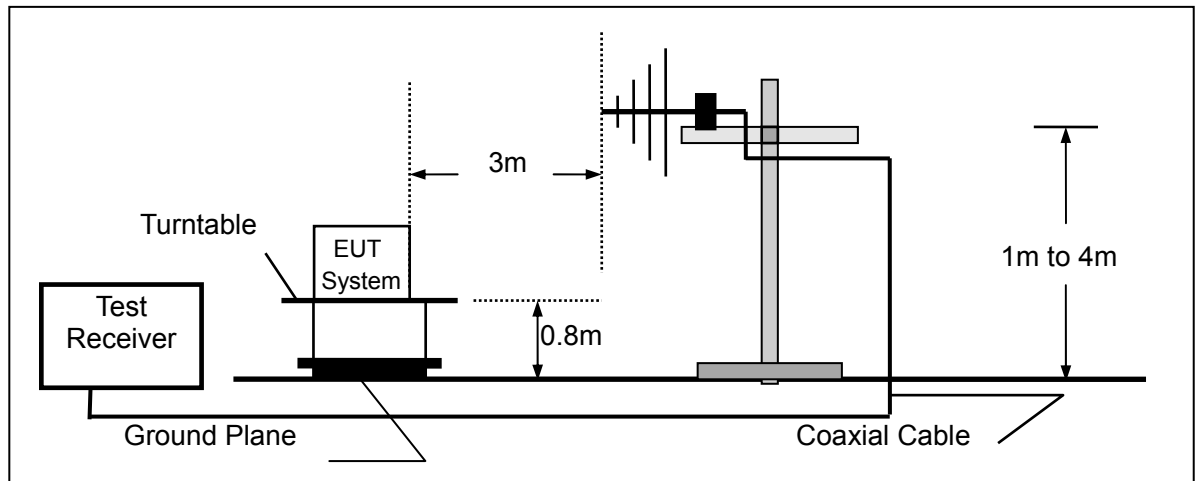

(EUT: LED LCD TV)

5.2. Measuring Standard

FCC Part 15, Subpart B, Class B ANSI C63.4: 2014

5.3. Radiated Emission Limits (Class B)

Frequency MHz	Distance Meters	Field Strengths Limit	
		$\mu\text{V}/\text{m}$	$\text{dB}(\mu\text{V})/\text{m}$
30 ~ 88	3	100	40.0
88 ~ 216	3	150	43.5
216 ~ 960	3	200	46.0
960 ~ 1000	3	500	54.0

Remark: (1) Emission level $(\text{dB})\mu\text{V} = 20 \log$ Emission level $\mu\text{V}/\text{m}$
(2) The smaller limit shall apply at the cross point between two frequency bands.
(3) Distance is the distance in meters between the measuring instrument, antenna and the closest point of any part of the device or system.

5.4. EUT Configuration on Measurement

The FCC Class B regulations test method must be used to find the maximum emission during radiated emission measurement.

EUT : LED LCD TV
Model Number : 43H3507

5.5. Operating Condition of EUT

5.5.1. Setup the EUT as shown on Section 5.1.

5.5.2. Turn on the power of all equipments.

5.5.3. Let the EUT work in measuring mode (HDMI IN1 ARC, HDMI IN 2, HDMI IN 3(PC)) and measure it.

5.6. Test Procedure

The EUT is placed on a turn table which is 0.8 meter high above the ground. The turn table can rotate 360 degrees to determine the position of the maximum emission level. The EUT is set 3 meters away from the receiving antenna which is mounted on a antenna tower. The antenna can be moved up and down from 1 to 4 meters to find out the maximum emission level. Bilog antenna (calibrated by Dipole Antenna) is used as a receiving antenna. Both horizontal and vertical polarization of the antenna is set on test.

The bandwidth of the Receiver (ESU26) is set at 120kHz.
The worst scanning curves are attached in following pages.

5.7. Measuring Results

PASS.

The frequency range from 30MHz to 6000MHz is investigated.

Please refer to following pages.

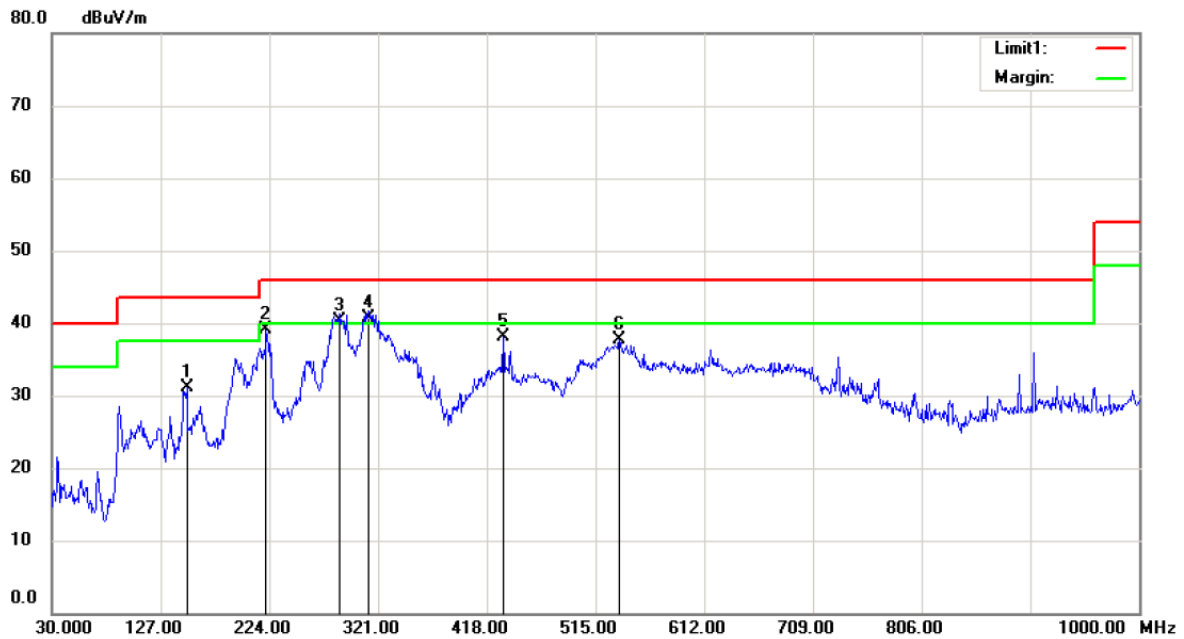

Site: 3m Chamber #1 Polarization: **Horizontal** Temperature: 22 C
 Limit: (RE)FCC PART 15 CLASS B Power: AC 120V/60Hz Humidity: 50 %
 Mode: HDMI 2.1
 Note:

No.	Mk.	Freq.	Reading Level	Correct Factor	Measurement	Limit	Over	Antenna Height	Table Degree	
		MHz	dBuV	dB	dBuV/m	dBuV/m	dB	cm	degree	Comment
1		150.2800	47.54	-16.51	31.03	43.50	-12.47			QP
2		221.0900	51.60	-12.53	39.07	46.00	-6.93			QP
3	!	287.0500	50.84	-10.54	40.30	46.00	-5.70			QP
4	*	312.2700	50.71	-9.91	40.80	46.00	-5.20			QP
5		432.5500	46.05	-7.92	38.13	46.00	-7.87			QP
6		536.3400	43.90	-6.10	37.80	46.00	-8.20			QP

*:Maximum data x:Over limit !:over margin

Operator: KK

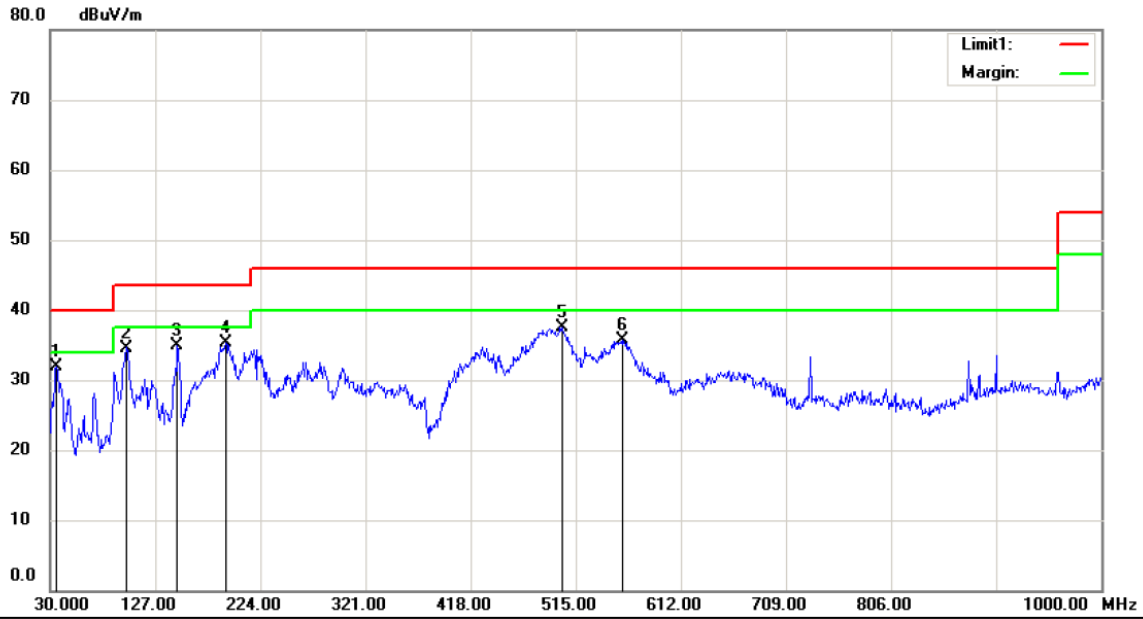

Site 3m Chamber #1 Polarization: **Vertical** Temperature: 22 C
 Limit: (RE)FCC PART 15 CLASS B Power: AC 120V/60Hz Humidity: 50 %
 Mode:HDMI 2(
 Note:

No.	Mk.	Freq.	Reading Level	Correct Factor	Measurement	Limit	Over	Antenna Height	Table Degree	
		MHz	dBuV	dB	dBuV/m	dBuV/m	dB	cm	degree	Comment
1	*	35.8200	45.65	-13.66	31.99	40.00	-8.01			QP
2		99.8400	47.16	-12.56	34.60	43.50	-8.90			QP
3		147.3700	51.80	-16.89	34.91	43.50	-8.59			QP
4		191.9900	49.01	-13.75	35.26	43.50	-8.24			QP
5		502.3900	44.45	-6.86	37.59	46.00	-8.41			QP
6		557.6800	41.26	-5.49	35.77	46.00	-10.23			QP

*:Maximum data x:Over limit !:over margin

Operator: KK

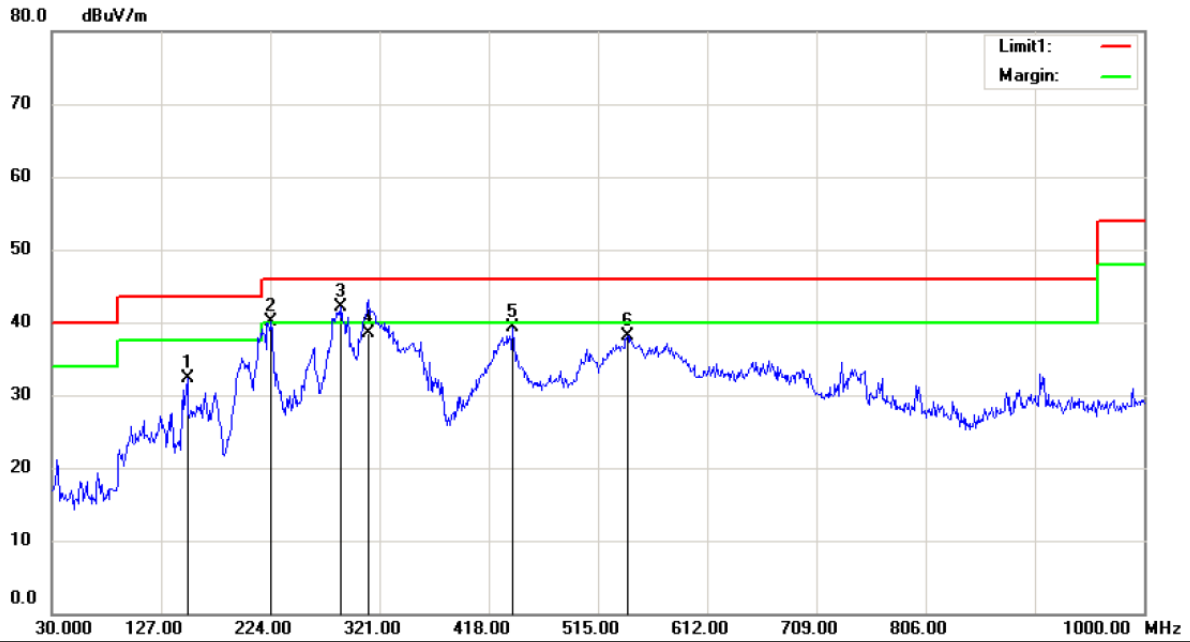

Site 3m Chamber #1 Polarization: **Horizontal** Temperature: 22 C
 Limit: (RE)FCC PART 15 CLASS B Power: AC 120V/60Hz Humidity: 50 %
 Mode: HDMI 3
 Note:

No.	Mk.	Freq.	Reading Level	Correct Factor	Measurement	Limit	Over	Antenna Height	Table Degree	
		MHz	dBuV	dB	dBuV/m	dBuV/m	dB	cm	degree	Comment
1		150.2800	48.79	-16.51	32.28	43.50	-11.22	QP		
2	!	224.9700	52.44	-12.43	40.01	46.00	-5.99	QP		
3	*	287.0500	52.60	-10.54	42.06	46.00	-3.94	QP		
4		311.3000	48.39	-9.89	38.50	46.00	-7.50	QP		
5		439.3400	46.94	-7.68	39.26	46.00	-6.74	QP		
6		541.1900	44.02	-5.90	38.12	46.00	-7.88	QP		

*:Maximum data x:Over limit !:over margin

Operator: KK

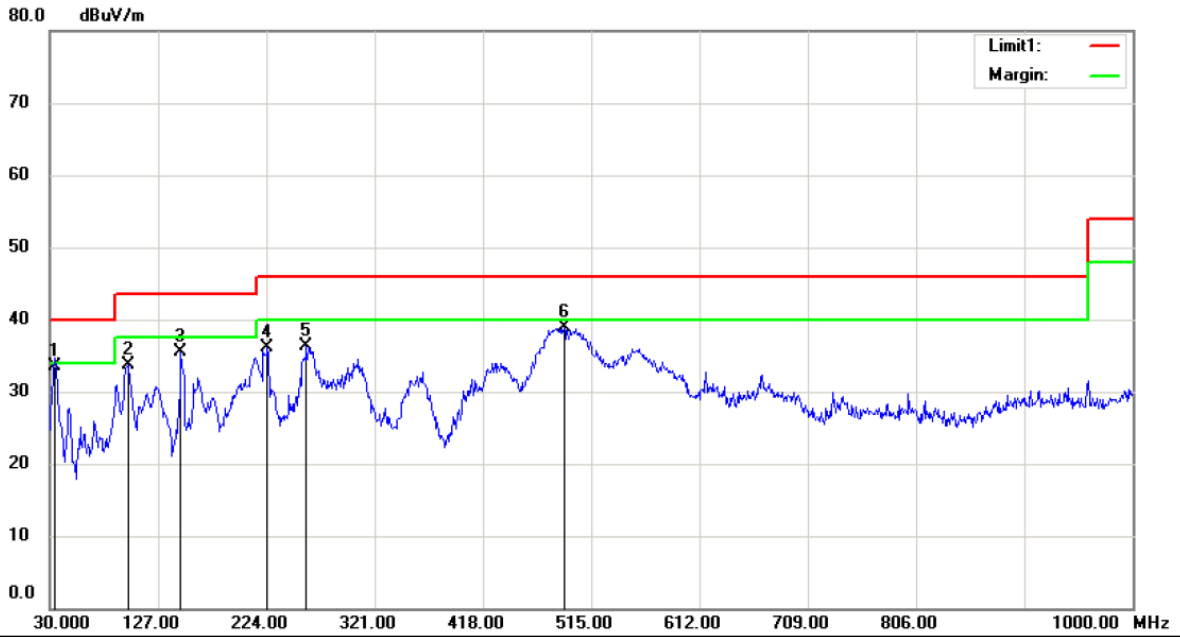

Site 3m Chamber #1 Polarization: **Vertical** Temperature: 22 C
 Limit: (RE)FCC PART 15 CLASS B Power: AC 120V/60Hz Humidity: 50 %
 Mode:HDMI 3i
 Note:

No.	Mk.	Freq.	Reading Level	Correct Factor	Measurement	Limit	Over	Antenna Height	Table Degree	Comment
		MHz	dBuV	dB	dBuV/m	dBuV/m	dB	cm	degree	
1	*	33.8800	47.46	-13.86	33.60	40.00	-6.40	QP		
2		99.8400	46.36	-12.56	33.80	43.50	-9.70	QP		
3		147.3700	52.31	-16.89	35.42	43.50	-8.08	QP		
4		224.9700	48.50	-12.43	36.07	46.00	-9.93	QP		
5		259.8900	47.04	-10.65	36.39	46.00	-9.61	QP		
6		490.7500	46.57	-7.65	38.92	46.00	-7.08	QP		

*:Maximum data x:Over limit !:over margin

Operator: KK

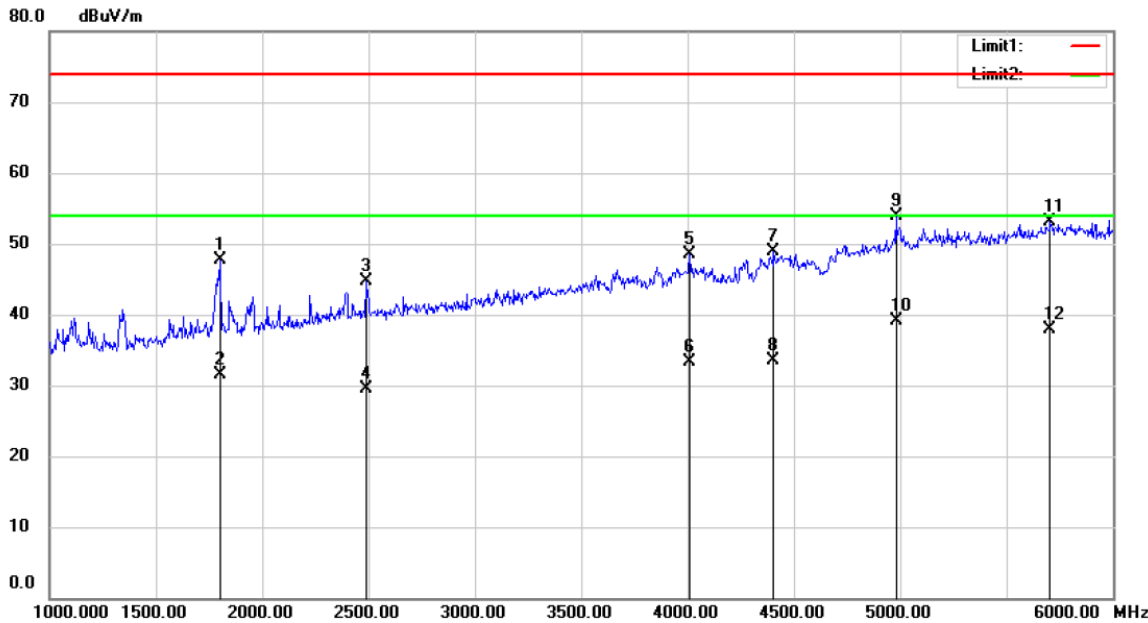

Site 3m Chamber #1 Polarization: **Horizontal** Temperature: 22 C
 Limit: (RE)FCC PART 15 CLASS B PEAK Power: AC 120V/60Hz Humidity: 50 %
 Mode:HDMI 1
 Note:

No.	Mk.	Freq. MHz	Reading Level dBuV	Correct Factor dB	Measure- ment dBuV/m	Limit dBuV/m	Over dB	Detector	Antenna Height cm	Table Degree degree	Comment
1		1800.000	57.43	-9.80	47.63	74.00	-26.37	peak			
2		1800.000	41.40	-9.80	31.60	54.00	-22.40	AVG			
3		2490.000	52.13	-7.52	44.61	74.00	-29.39	peak			
4		2490.000	37.09	-7.52	29.57	54.00	-24.43	AVG			
5		4010.000	50.60	-2.16	48.44	74.00	-25.56	peak			
6		4010.000	35.41	-2.16	33.25	54.00	-20.75	AVG			
7		4405.000	49.92	-1.09	48.83	74.00	-25.17	peak			
8		4405.000	34.58	-1.09	33.49	54.00	-20.51	AVG			
9		4980.000	53.43	0.48	53.91	74.00	-20.09	peak			
10	*	4980.000	38.53	0.48	39.01	54.00	-14.99	AVG			
11		5705.000	51.18	1.88	53.06	74.00	-20.94	peak			
12		5705.000	36.10	1.88	37.98	54.00	-16.02	AVG			

*:Maximum data x:Over limit !:over margin

Operator: KK

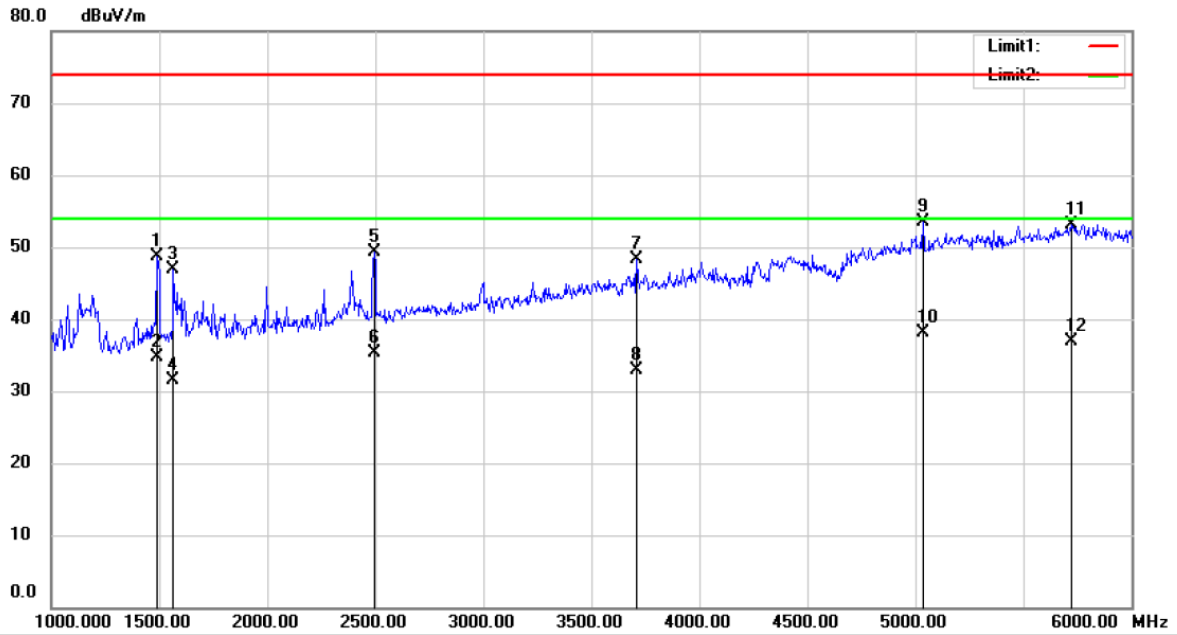

Site 3m Chamber #1 Polarization: **Vertical** Temperature: 22 C
 Limit: (RE)FCC PART 15 CLASS B PEAK Power: AC 120V/60Hz Humidity: 50 %
 Mode:HDMI 1
 Note:

No.	Mk.	Freq.	Reading Level	Correct Factor	Measurement	Limit	Over	Antenna Height	Table Degree	
		MHz	dBuV	dB	dBuV/m	dBuV/m	dB	cm	degree	Comment
1		1490.000	59.55	-10.75	48.80	74.00	-25.20			peak
2		1490.000	45.55	-10.75	34.80	54.00	-19.20			AVG
3		1565.000	57.36	-10.52	46.84	74.00	-27.16			peak
4		1565.000	41.95	-10.52	31.43	54.00	-22.57			AVG
5		2495.000	56.78	-7.51	49.27	74.00	-24.73			peak
6		2495.000	42.88	-7.51	35.37	54.00	-18.63			AVG
7		3710.000	51.47	-3.23	48.24	74.00	-25.76			peak
8		3710.000	36.04	-3.23	32.81	54.00	-21.19			AVG
9		5035.000	52.85	0.60	53.45	74.00	-20.55			peak
10	*	5035.000	37.51	0.60	38.11	54.00	-15.89			AVG
11		5720.000	51.23	1.90	53.13	74.00	-20.87			peak
12		5720.000	34.98	1.90	36.88	54.00	-17.12			AVG

*:Maximum data x:Over limit !:over margin

Operator: KK

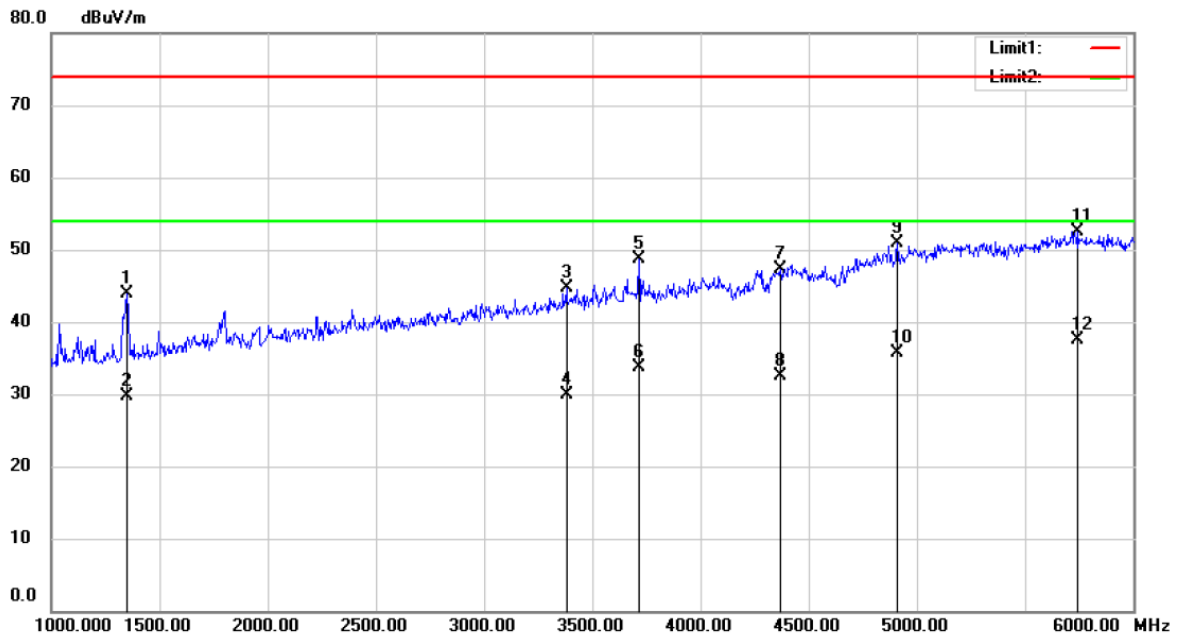

Site 3m Chamber #1 Polarization: **Horizontal** Temperature: 22 C
 Limit: (RE)FCC PART 15 CLASS B PEAK Power: AC 120V/60Hz Humidity: 50 %
 Mode:HDMI 2
 Note:

No.	Mk.	Freq. MHz	Reading Level dBuV	Correct Factor dB	Measure- ment dBuV/m	Limit dBuV/m	Over dB	Antenna Height cm	Table Degree	Comment
1		1350.000	54.97	-11.16	43.81	74.00	-30.19	peak		
2		1350.000	40.82	-11.16	29.66	54.00	-24.34	AVG		
3		3380.000	49.23	-4.44	44.79	74.00	-29.21	peak		
4		3380.000	34.36	-4.44	29.92	54.00	-24.08	AVG		
5		3715.000	52.01	-3.22	48.79	74.00	-25.21	peak		
6		3715.000	36.84	-3.22	33.62	54.00	-20.38	AVG		
7		4370.000	48.56	-1.18	47.38	74.00	-26.62	peak		
8		4370.000	33.68	-1.18	32.50	54.00	-21.50	AVG		
9		4910.000	50.70	0.29	50.99	74.00	-23.01	peak		
10		4910.000	35.33	0.29	35.62	54.00	-18.38	AVG		
11		5745.000	50.61	1.95	52.56	74.00	-21.44	peak		
12	*	5745.000	35.54	1.95	37.49	54.00	-16.51	AVG		

*:Maximum data x:Over limit !:over margin

Operator: KK

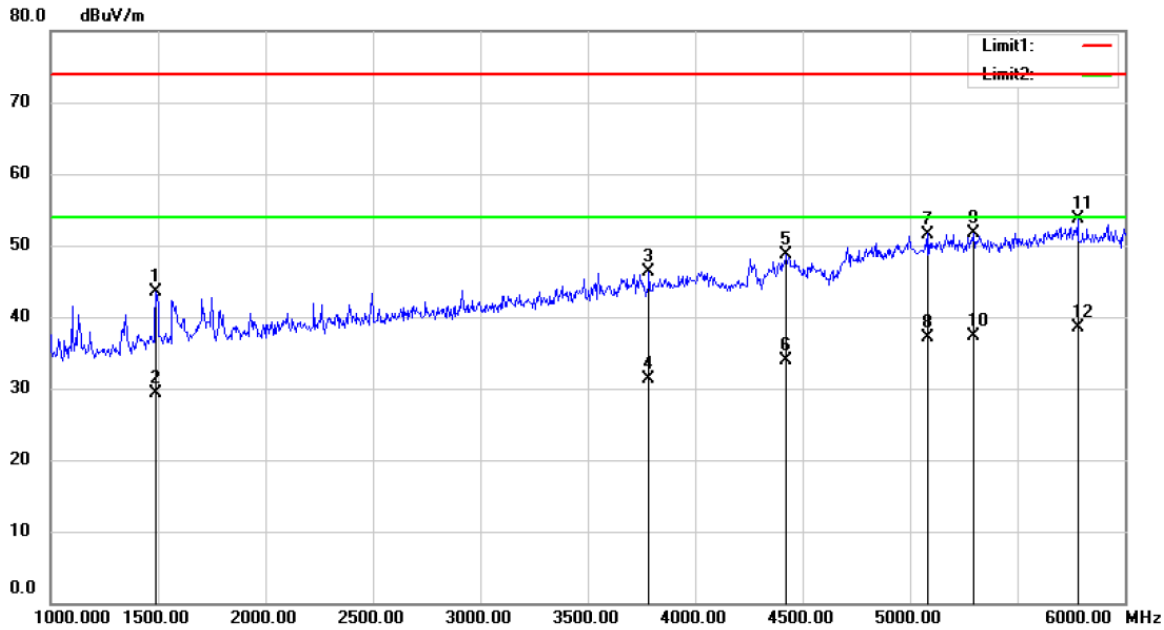

Site 3m Chamber #1 Polarization: **Vertical** Temperature: 22 C
 Limit: (RE)FCC PART 15 CLASS B PEAK Power: AC 120V/60Hz Humidity: 50 %
 Mode:HDMI 2
 Note:

No.	Mk.	Freq. MHz	Reading Level dBuV	Correct Factor dB	Measure- ment dBuV/m	Limit dBuV/m	Over dB	Detector	Antenna Height cm	Table Degree	Comment
1		1490.000	54.25	-10.75	43.50	74.00	-30.50	peak			
2		1490.000	40.15	-10.75	29.40	54.00	-24.60	AVG			
3		3785.000	49.35	-2.97	46.38	74.00	-27.62	peak			
4		3785.000	34.36	-2.97	31.39	54.00	-22.61	AVG			
5		4425.000	49.66	-1.04	48.62	74.00	-25.38	peak			
6		4425.000	35.02	-1.04	33.98	54.00	-20.02	AVG			
7		5085.000	50.90	0.70	51.60	74.00	-22.40	peak			
8		5085.000	36.41	0.70	37.11	54.00	-16.89	AVG			
9		5295.000	50.52	1.10	51.62	74.00	-22.38	peak			
10		5295.000	36.24	1.10	37.34	54.00	-16.66	AVG			
11		5780.000	51.77	2.03	53.80	74.00	-20.20	peak			
12	*	5780.000	36.46	2.03	38.49	54.00	-15.51	AVG			

*:Maximum data x:Over limit !:over margin

Operator: KK

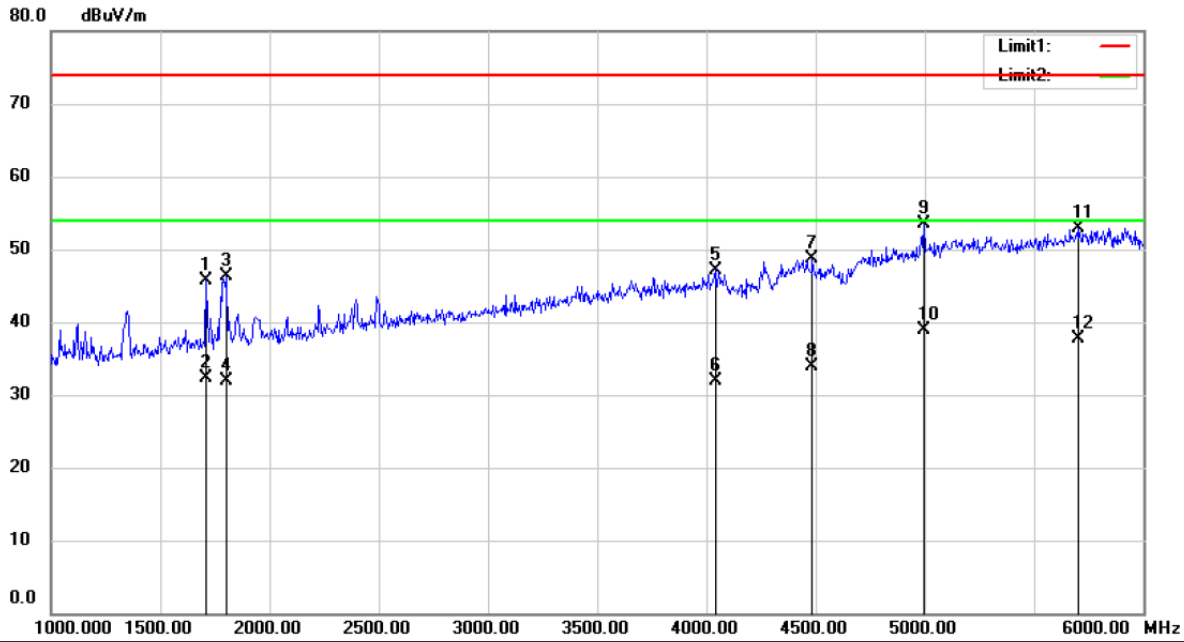

Site 3m Chamber #1

Polarization: **Horizontal**

Temperature: 22 C

Limit: (RE)FCC PART 15 CLASS B PEAK

Power: AC 120V/60Hz

Humidity: 50 %

Mode:HDMI 3

Note:

No.	Mk.	Freq. MHz	Reading Level dBuV	Correct Factor dB	Measure- ment dBuV/m	Limit dBuV/m	Over dB	Antenna Height cm	Table Degree	Comment
1		1710.000	55.74	-10.07	45.67	74.00	-28.33	peak		
2		1710.000	42.34	-10.07	32.27	54.00	-21.73	AVG		
3		1800.000	56.07	-9.80	46.27	74.00	-27.73	peak		
4		1800.000	41.80	-9.80	32.00	54.00	-22.00	AVG		
5		4040.000	49.28	-2.08	47.20	74.00	-26.80	peak		
6		4040.000	34.03	-2.08	31.95	54.00	-22.05	AVG		
7		4485.000	49.64	-0.88	48.76	74.00	-25.24	peak		
8		4485.000	34.85	-0.88	33.97	54.00	-20.03	AVG		
9		4995.000	52.96	0.52	53.48	74.00	-20.52	peak		
10	*	4995.000	38.48	0.52	39.00	54.00	-15.00	AVG		
11		5705.000	51.10	1.88	52.98	74.00	-21.02	peak		
12		5705.000	35.80	1.88	37.68	54.00	-16.32	AVG		

*:Maximum data x:Over limit !:over margin

Operator: KK

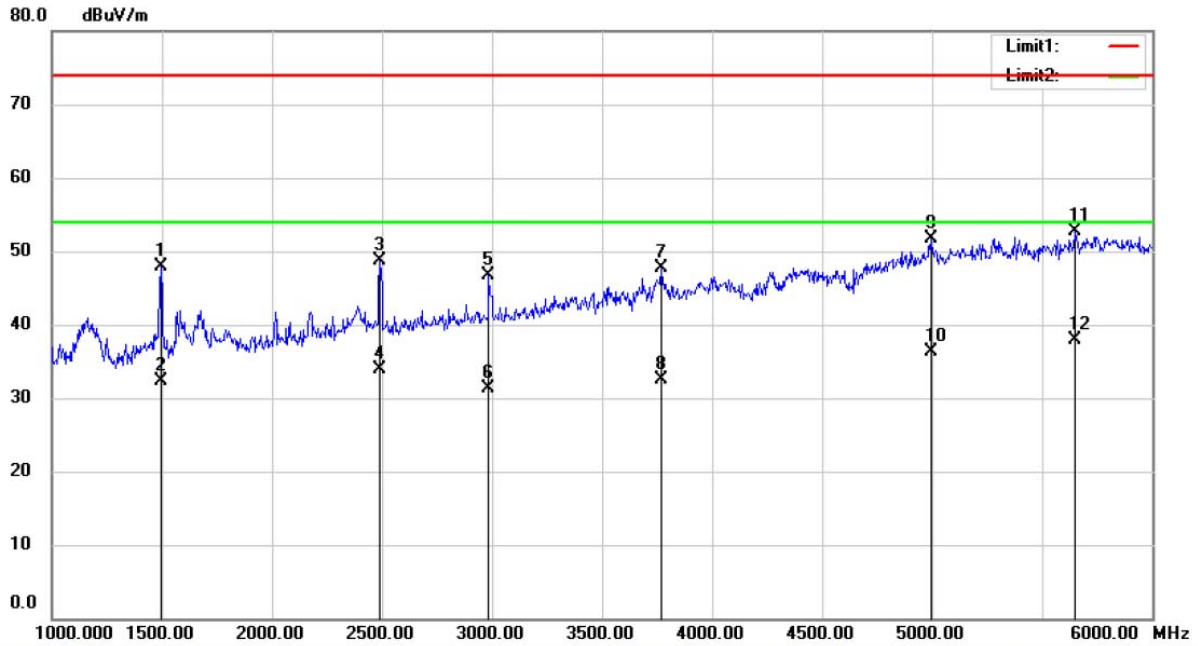

Site 3m Chamber #1 Polarization: **Vertical** Temperature: 22 C
 Limit: (RE)FCC PART 15 CLASS B PEAK Power: AC 120V/60Hz Humidity: 50 %
 Mode:HDMI 3
 Note:

No.	Mk.	Freq. MHz	Reading Level dBuV	Correct Factor dB	Measure- ment dBuV/m	Limit dBuV/m	Over dB	Detector	Antenna Height cm	Table Degree	Comment
1		1495.000	58.61	-10.73	47.88	74.00	-26.12	peak			
2		1495.000	43.03	-10.73	32.30	54.00	-21.70	AVG			
3		2490.000	56.17	-7.52	48.65	74.00	-25.35	peak			
4		2490.000	41.49	-7.52	33.97	54.00	-20.03	AVG			
5		2985.000	52.61	-5.85	46.76	74.00	-27.24	peak			
6		2985.000	37.22	-5.85	31.37	54.00	-22.63	AVG			
7		3770.000	50.75	-3.02	47.73	74.00	-26.27	peak			
8		3770.000	35.59	-3.02	32.57	54.00	-21.43	AVG			
9		4995.000	51.16	0.52	51.68	74.00	-22.32	peak			
10		4995.000	35.78	0.52	36.30	54.00	-17.70	AVG			
11		5650.000	50.91	1.78	52.69	74.00	-21.31	peak			
12	*	5650.000	36.10	1.78	37.88	54.00	-16.12	AVG			

*:Maximum data x:Over limit !:over margin

Operator: KK

-----THE END-----