

Application for FCC Certificate
On Behalf of
Hisense Electric Co., Ltd.

LED LCD TV

Model No.	Brand
40H5B	Hisense
40H5B+	
40H5C+	

FCC ID: W9HLCDD0058

Prepared For : Hisense Electric Co., Ltd.
No.218 Qianwangang Road, Economy & Technology
Development Zone, Qingdao, China

Prepared By : Audix Technology (Shanghai) Co., Ltd.
3F and 4F, 34Bldg 680 Guiping Rd,
Caohejing Hi-Tech Park,
Shanghai 200233, China

Tel: +86-21-64955500
Fax: +86-21-64955491

Report No. : ACI-F16128
Date of Test : May 08- 18, 2016
Date of Report : May 26, 2016

TABLE OF CONTENTS

	Page
1 SUMMARY OF STANDARDS AND RESULTS	4
1.1 Description of Standards and Results.....	4
2 GENERAL INFORMATION	5
2.1 Description of Equipment Under Test.....	5
2.2 Peripherals.....	6
2.3 Description of Test Facility.....	8
2.4 Measurement Uncertainty.....	8
3 CONDUCTED EMISSION TEST	9
3.1 Test Equipment.....	9
3.2 Block Diagram of Test Setup.....	9
3.3 Conducted Emission Limit [FCC Part 15 Subpart B 15.107(a)].....	10
3.4 Test Configuration.....	10
3.5 Operating Condition of EUT.....	11
3.6 Test Procedures.....	11
3.7 Test Results.....	12
4 RADIATED EMISSION TEST	19
4.1 Test Equipment.....	19
4.2 Block Diagram of Test Setup.....	19
4.3 Radiated Emission Limit [FCC Part 15 Subpart B 15.109(a)].....	21
4.4 Test Configuration.....	21
4.5 Operating Condition of EUT.....	21
4.6 Test Procedures.....	21
4.7 Test Results.....	22
5 DEBUG DESCRIPTION	30
6 DEVIATION TO TEST SPECIFICATIONS	31

TEST REPORT FOR FCC CERTIFICATE

Applicant : Hisense Electric Co., Ltd.
 Manufacturer : Hisense Electric Co., Ltd.
 Factory #1 : Hisense Electric Co., Ltd.
 Factory #2 : Tatung Mexico S.A. de C.V.
 Factory #3 : HISENSE ELECTRONICA MEXICO, S.A. DE C.V.
 EUT Description : LED LCD TV

Model No.	Brand	Power Supply
Refer to Sec.2.1	Hisense	120V/60Hz

Test Procedure Used:

*FCC RULES AND REGULATIONS PART 15 SUBPART B CLASS B OCTOBER 2015
AND ANSI C63.4-2014*

The device described above is tested by Audix Technology (Shanghai) Co., Ltd. to determine the maximum emission levels emanating from the device. The maximum emission levels are compared to the FCC Part 15 Subpart B (Class B) limits both radiated and conducted emissions.

The test results are contained in this test report and Audix Technology (Shanghai) Co., Ltd. is assumed full responsibility for the accuracy and completeness of these measurements. This report shows that the EUT (M/N: Refer to Sec2.1) which was tested in 3m anechoic chamber May 08- 18, 2016 is technically compliance with the FCC official limits also.

This report applies to above tested sample only. This report shall not be reproduced in part without written approval of Audix Technology (Shanghai) Co., Ltd.

This report contains data that are not covered by the NVLAP accreditation.

This report must not be used by the client to claim product certification, approval, or endorsement by NVLAP, NIST, or any agency of the federal government.

The test results for EUT's TV functions are contained in No.F16127, a Verification report.

Date of Test : May 08- 18, 2016 Date of Report : May 26, 2016

Producer : Huimin Yan
 HUI MIN YAN / Assistant

Review : Byron Wu
 BYRON WU / Deputy Assistant Manager

 For and on behalf of
 Audix Technology (Shanghai) Co., Ltd.

Signatory : 
 Authorized Signature EMC BYRON KWOW / Assistant General Manager

1 SUMMARY OF STANDARDS AND RESULTS

1.1 Description of Standards and Results

The EUT have been tested according to the applicable standards as referenced below:

Description of Test Item	Standard	Limits	Results
EMISSION			
Conducted Disturbance at the Mains Terminal	FCC RULES AND REGULATIONS PART 15 SUBPART B OCTOBER 2015 AND ANSI C63.4-2014	15.107(a) Class B	Pass
Radiated Disturbance	FCC RULES AND REGULATIONS PART 15 SUBPART B OCTOBER 2015 AND ANSI C63.4-2014	15.109(a) Class B	Pass

2 GENERAL INFORMATION

2.1 Description of Equipment Under Test

Description	:	LED LCD TV
Type of EUT	:	<input checked="" type="checkbox"/> Production <input type="checkbox"/> Pre-product <input type="checkbox"/> Pro-type
Model No	:	40H5B, 40H5B+, 40H5C+
Note#1	:	The above models are all the same except for model number.40H5B model is tested and recorded in the report.
Note#2	:	“+”represents any of the Arabic numeral, or spaces.
Brand	:	Hisense
Applicant	:	Hisense Electric Co., Ltd. No.218 Qianwangang Road, Economy & Technology Development Zone, Qingdao, China
Manufacturer	:	same as Applicant
Factory #1	:	same as Applicant
Factory #2	:	Tatung Mexico S.A. de C.V. Miguel Catalán 420, Parque Industrial Rio Bravo, Cd. Juarez, Chih., CP 32557
Factory #3	:	HISENSE ELECTRONICA MEXICO, S.A.DE C.V. Blvd. Sharp #3510 Parque Industrial Rosarito, C.P. 22710 Playas de Rosarito, B.C.
LCD Panel	:	Manufacturer : Hisense M/N : HD400DF-E32
Tuner	:	Manufacturer : XuGuang Tech. Co., Ltd. M/N : HFT-96S3/W11FJ4H\ROH
Max Resolution	:	1920*1080@60Hz
HDMI Cable*2 (Lab provide)	:	Shielded, Detachable, 1.50m
Power Cord	:	Unshielded, Detachable, 1.80m, 2C
LAN Cable	:	Shielded, Detachable, 1.50m
USB Cable	:	Shielded, Detachable, 1.00m

Remark:

The EUT is a LED LCD TV which input/output ports as follows:

Side Port:

- (1) One COMPONENT IN Port : Connected with DVD PLAYER
- (2) One AV IN Port : Connected with DVD PLAYER
- (3) One HDMI1 Port : Connected with DVD PLAYER
- (4) One HDMI 2 Port : Connected with PC
- (5) One Audio out Port : Connected with Earphone#1
- (6) One ANT/CABLE IN Port : Connected with Antenna or ATSC SG / TV SG

Side Port:

- (7) One SERVICE Port : Do not open to customer
- (8) One LAN Port : Connected with PC
- (9) One USB Port : Connected with Hard-Disk
- (10) One Digital Audio Out Port : Connected with Audio Converter to Earphone#2

2.2 Peripherals

2.2.1 PC

Manufacturer : HP
Model Number : dx7400MT
Serial Number : CNG8130K89
Power Cord : Unshielded, Detachable, 1.8m
Certificate : FCC DoC; CE/EMC; VCCI; C-Tick;

2.2.2 Keyboard

Manufacturer : Microsoft
Model Number : RT2300
Serial Number : 7668200662248
Data Cable : Shielded, undetachable, 1.8m
Certificate : CE/EMC, FCC DoC, VCCI, MIC,
C-Tick, BSMI

2.2.3 Mouse

Manufacturer : Microsoft
Model Number : RT2300
Serial Number : 6965712071551
Data Cable : Shielded, Undetachable, 1.8m.
Certificate : CE/EMC, FCC DoC, VCCI, MIC,
C-Tick, BSMI

2.2.4 Modem

Manufacturer : TP-LINK
Model Number : TM-EC5658V
Serial Number : 07123301053
Data Cable : Shielded, Detachable, 1.8m
Certificate : CCC

2.2.5 Earphone*2

Manufacturer : EDIFIER
Model Number : H210

2.2.6 TV Signal Generator

Manufacturer : FLUKE
Model Number : 54200M01
Serial Number : 814008

2.2.7 ATSC Signal Generator

Manufacturer : SENCORE
Model Number : ATSC997
Serial Number : 6790071

2.2.8 DVD PLAYER

Manufacturer : PHILIPS
Model Number : DVP3986K/93
Serial Number : KX1A0902120108
Certificate : CCC

2.2.9 Hard Disk

Manufacturer : Tetasys
Model Number : F12
Serial Number : A010022-486006
Data Cable : Shielded, Undetachable, 1.8m.
Certificate : CE, FCC DoC

2.3 Description of Test Facility

Site Description (No.3 3m Chamber) : Sept. 17, 1998 file on
Jan.15, 2015 Renewed
Federal Communications Commission
FCC Engineering Laboratory
7435 Oakland Mills Road
Columbia, MD 21046, USA

Name of Firm : Audix Technology (Shanghai) Co., Ltd.

Site Location : 3F 34Bldg 680 Guiping Rd,
Caohejing Hi-Tech Park,
Shanghai 200233, China

NVLAP Lab Code : 200371-0

2.4 Measurement Uncertainty

Conducted Emission Expanded Uncertainty : U = 3.4dB

Radiated Emission Expanded Uncertainty (30-200MHz):
U = 4.6dB (Horizontal)
U = 4.3dB (Vertical)

Radiated Emission Expanded Uncertainty (200M-1GHz):
U = 4.5dB (Horizontal)
U = 5.4dB (Vertical)

Radiated Emission Expanded Uncertainty (1GHz-6GHz):
U = 5.1dB

3 CONDUCTED EMISSION TEST

3.1 Test Equipment

The following test equipments are used during the conducted emission test in a shielded room:

Item	Type	Manufacturer	Model No.	Serial No.	Last Cal.	Next Cal.
1.	Test Receiver	R&S	ESCI	101302	Jul 03, 2015	Jul 02, 2016
2.	Artificial Mains Network (AMN)	R&S	ENV4200	100125	Jun 27, 2015	Jun 26, 2016
3.	Line Impedance Stabilization Network (LISN)	Kyoritsu	KNW-407	8-1280-4	Mar 20, 2016	Mar 19, 2017
4.	50Ω Terminator	Anritsu	BNC	001	Mar 18, 2016	Sep 17, 2016
5.	Software	Audix	e3	6.111206	--	--

3.2 Block Diagram of Test Setup

3.2.1 EUT & Peripherals

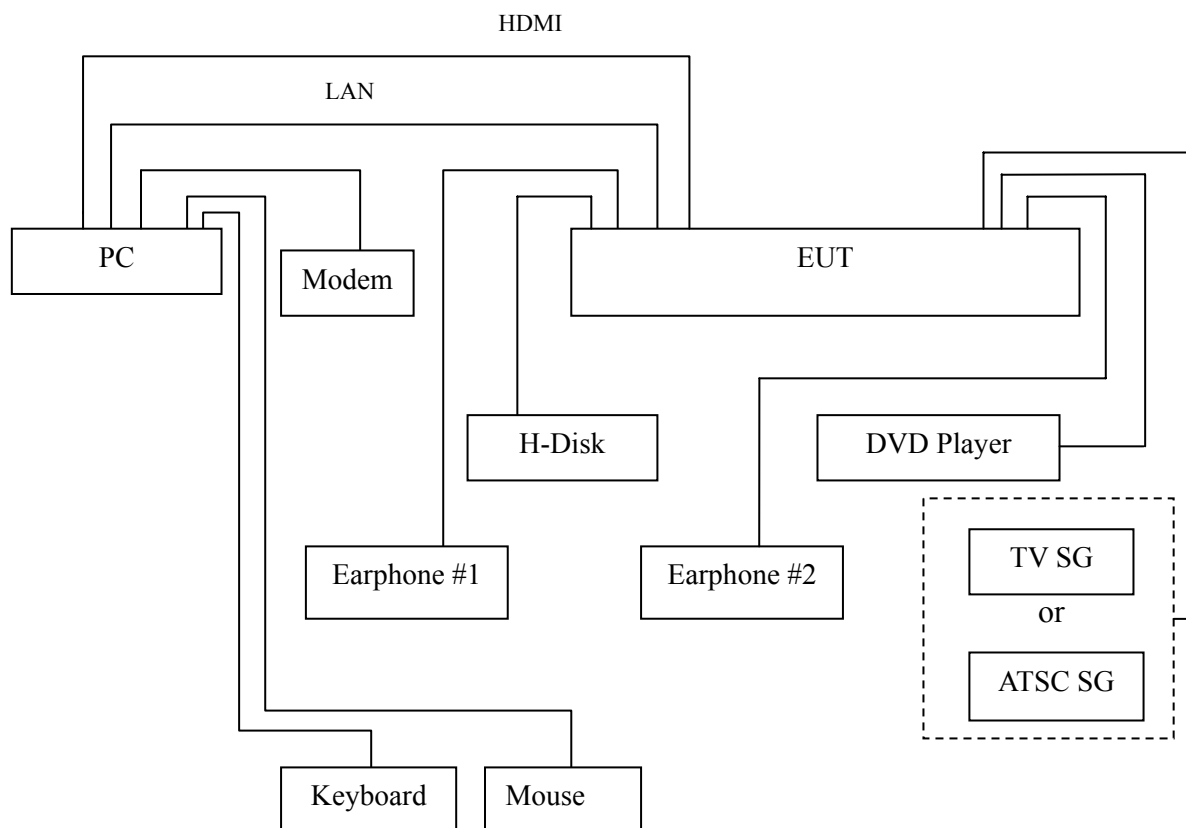

3.2.2 Conducted Disturbance Test Setup

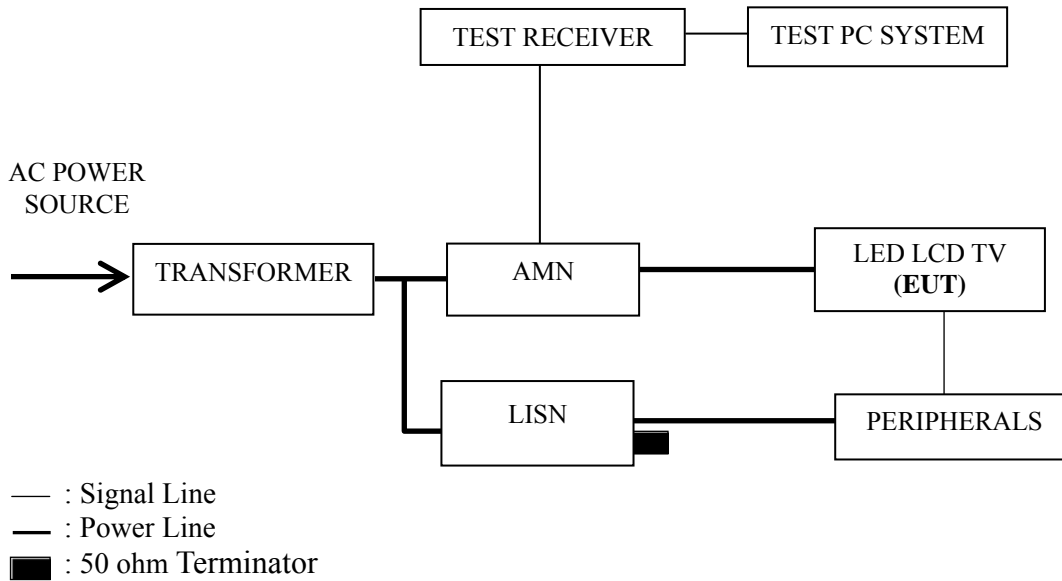

3.3 Conducted Emission Limit [FCC Part 15 Subpart B 15.107(a)]

Frequency Range (MHz)	Limits dB (μ V)	
	Quasi-peak	Average
0.15 ~ 0.5	66~56	56~46
0.5 ~ 5	56	46
5 ~ 30	60	50

NOTE 1 – The lower limit shall apply at the transition frequencies.
 NOTE 2 – The limit decreases linearly with the logarithm of the frequency in the range 0.15 MHz~0.50 MHz

3.4 Test Configuration

The EUT (listed in Sec.2.1) and the peripherals (listed in Sec 2.2) were installed as shown on Sec.3.2 to meet FCC requirement and operating in a manner that tends to maximize its emission level in a normal application.

3.5 Operating Condition of EUT

- 3.5.1 Setup the EUT and peripherals as shown in Sec. 3.2.
- 3.5.2 Turn on the power of all equipments and the EUT.
- 3.5.3 Set the contrast & brightness of EUT to maximum.
- 3.5.4 PC system ran the self-test program “EMC Test” by windows XP and sent “H” characters to EUT through graphic card, the EUT’s screen displayed and filled with “H” pattern by its resolution (Via HDMI Input).
- 3.5.5 PC system sent the 1kHz audio signal to EUT through audio port, the EUT speak out 1kHz audio signal.
- 3.5.6 In USB Play mode, set the EUT play digital media from Hard Disk.
- 3.5.7 In LAN Play mode, set the EUT play digital media through LAN port.
- 3.5.8 The other peripherals devices were driven and operated during the test.
- 3.5.9 The test modes are as follows:

Test Mode
HDMI 1920*1080@60Hz & 1kHz playing
HDMI 1280*1024@60Hz & 1kHz playing
HDMI 640*480@60Hz & 1kHz playing
HDMI1080P
USB Play
LAN Play

3.6 Test Procedures

The EUT and peripherals were connected to the power mains through an Artificial Mains Network (AMN). This provided a 50 ohm coupling impedance for the measuring equipment.

Both sides of AC line (Line & Neutral) were checked for maximum conducted interference. In order to find the maximum emission, the relative positions of equipment and all of the interface cables were changed or manipulated according to ANSI C63.4:2014 during conducted emission test.

The bandwidth of R&S Test Receiver ESCI was set at 9 kHz.

The frequency range from 150 kHz to 30 MHz was checked.

The test modes were done on conducted disturbance test and all the test results are listed in Sec. 3.7.

3.7 Test Results

< **PASS** >

The frequency and amplitude of the highest conducted emission relative to the limit is reported. All emissions not reported below are too low against the prescribed limits.

Test Mode	Data Page
HDMI 1920*1080@60Hz & 1kHz playing	P13
HDMI 1280*1024@60Hz & 1kHz playing	P14
HDMI 640*480@60Hz & 1kHz playing	P15
HDMI1080P	P16
USB Play	P17
LAN Play	P18

NOTE 1 – Factor = Cable Loss + AMN Factor.

NOTE 2 – Emission Level = Meter Reading + Factor.

NOTE 3 – “QP” means “Quasi-Peak” values, “AV” means “Average” values.

NOTE 4 – The worst case is for LAN Play test mode. The worst emission is detected at 3.427MHz (Average Value) with corrected signal level of 37.95 dB (μ V) (limit is 46.00 dB (μ V)), when the Neutral of the EUT is connected to AMN.

EUT : LED LCD TV Temperature : 22°C

Model No. : 40H5B Humidity : 48%RH

Test Mode : HDMI 1920*1080@60Hz Date of Test : Mar 08, 2016
& 1kHz Playing

Test Line	Frequency (MHz)	Meter Reading dB(μV)	Factor (dB)	Emission Level dB(μV)	Limits dB(μV)	Margin (dB)	Remark
Line	0.207	37.10	10.52	47.62	63.34	15.72	QP
	0.436	30.70	10.41	41.11	57.14	16.03	
	0.745	32.80	10.38	43.18	56.00	12.82	
	1.528	23.20	10.40	33.60	56.00	22.40	
	3.384	26.90	10.45	37.35	56.00	18.65	
	9.975	27.60	10.49	38.09	60.00	21.91	
	AV	0.207	25.20	10.52	35.72	53.34	17.62
		0.436	15.80	10.41	26.21	47.14	20.93
		0.745	21.50	10.38	31.88	46.00	14.12
		1.528	14.40	10.40	24.80	46.00	21.20
		3.384	19.30	10.45	29.75	46.00	16.25
		9.975	18.50	10.49	28.99	50.00	21.01
Neutral	0.153	39.30	10.58	49.88	65.81	15.93	QP
	0.384	34.50	10.41	44.91	58.18	13.27	
	0.746	31.40	10.36	41.76	56.00	14.24	
	1.531	30.40	10.39	40.79	56.00	15.21	
	3.308	33.79	10.45	44.24	56.00	11.76	
	9.727	29.50	10.56	40.06	60.00	19.94	
	AV	0.153	25.60	10.58	36.18	55.81	19.63
		0.384	24.20	10.41	34.61	48.18	13.57
		0.746	21.00	10.36	31.36	46.00	14.64
		1.531	21.60	10.39	31.99	46.00	14.01
		3.308	26.29	10.45	36.74	46.00	9.26
		9.727	20.10	10.56	30.66	50.00	19.34

TEST ENGINEER: SEVEN LU

EUT : LED LCD TV Temperature : 22°C

Model No. : 40H5B Humidity : 48%RH

Test Mode : HDMI 1280*1024@60Hz & 1kHz Playing Date of Test : Mar 08, 2016

Test Line	Frequency (MHz)	Meter Reading dB(μ V)	Factor (dB)	Emission Level dB(μ V)	Limits dB(μ V)	Margin (dB)	Remark
Line	0.152	42.19	10.59	52.78	65.91	13.13	QP
	0.376	33.60	10.43	44.03	58.37	14.34	
	0.627	28.70	10.38	39.08	56.00	16.92	
	1.369	25.70	10.39	36.09	56.00	19.91	
	3.415	26.80	10.45	37.25	56.00	18.75	
	9.564	26.40	10.49	36.89	60.00	23.11	
	AV	0.152	31.49	10.59	42.08	55.91	13.83
		0.376	23.30	10.43	33.73	48.37	14.64
		0.627	22.60	10.38	32.98	46.00	13.02
		1.369	16.60	10.39	26.99	46.00	19.01
		3.415	19.20	10.45	29.65	46.00	16.35
		9.564	18.90	10.49	29.39	50.00	20.61
Neutral	0.153	40.69	10.59	51.28	65.86	14.58	QP
	0.394	34.39	10.41	44.80	57.98	13.18	
	0.574	33.40	10.36	43.76	56.00	12.24	
	1.492	30.50	10.39	40.89	56.00	15.11	
	3.248	34.19	10.45	44.64	56.00	11.36	
	9.463	28.79	10.56	39.35	60.00	20.65	
	AV	0.153	29.79	10.59	40.38	55.86	15.48
		0.394	24.89	10.41	35.30	47.98	12.68
		0.574	20.20	10.36	30.56	46.00	15.44
		1.492	21.70	10.39	32.09	46.00	13.91
		3.248	26.59	10.45	37.04	46.00	8.96
		9.463	20.49	10.56	31.05	50.00	18.95

TEST ENGINEER: SEVEN LU

EUT : LED LCD TV Temperature : 22°C

Model No. : 40H5B Humidity : 48%RH

Test Mode : HDMI 640*480@60Hz & 1kHz Playing Date of Test : Mar 08, 2016

Test Line	Frequency (MHz)	Meter Reading dB(μ V)	Factor (dB)	Emission Level dB(μ V)	Limits dB(μ V)	Margin (dB)	Remark
Line	0.151	42.09	10.59	52.68	65.97	13.29	QP
	0.350	34.50	10.44	44.94	58.96	14.02	
	0.628	28.40	10.38	38.78	56.00	17.22	
	1.367	25.60	10.39	35.99	56.00	20.01	
	3.392	27.80	10.45	38.25	56.00	17.75	
	9.883	27.30	10.49	37.79	60.00	22.21	
	AV	0.151	31.19	10.59	41.78	55.97	14.19
		0.350	25.60	10.44	36.04	48.96	12.92
		0.628	22.30	10.38	32.68	46.00	13.32
		1.367	16.30	10.39	26.69	46.00	19.31
		3.392	19.70	10.45	30.15	46.00	15.85
		9.883	18.20	10.49	28.69	50.00	21.31
Neutral	0.151	40.99	10.59	51.58	65.94	14.36	QP
	0.387	34.40	10.41	44.81	58.14	13.33	
	0.578	33.90	10.36	44.26	56.00	11.74	
	2.041	32.80	10.41	43.21	56.00	12.79	
	3.392	35.29	10.45	45.74	56.00	10.26	
	9.664	29.30	10.56	39.86	60.00	20.14	
	AV	0.151	30.39	10.59	40.98	55.94	14.96
		0.387	24.20	10.41	34.61	48.14	13.53
		0.578	19.50	10.36	29.86	46.00	16.14
		2.041	23.20	10.41	33.61	46.00	12.39
		3.392	27.49	10.45	37.94	46.00	8.06
		9.664	20.00	10.56	30.56	50.00	19.44

TEST ENGINEER: SEVEN LU

EUT : LED LCD TV Temperature : 22°C
 Model No. : 40H5B Humidity : 48%RH
 Test Mode : HDMI1080P Date of Test : Mar 08, 2016

Test Line	Frequency (MHz)	Meter Reading dB(μ V)	Factor (dB)	Emission Level dB(μ V)	Limits dB(μ V)	Margin (dB)	Remark
Line	0.152	42.09	10.59	52.68	65.88	13.20	QP
	0.380	33.50	10.43	43.93	58.28	14.35	
	0.824	26.70	10.38	37.08	56.00	18.92	
	1.379	27.20	10.39	37.59	56.00	18.41	
	3.313	27.30	10.45	37.75	56.00	18.25	
	9.787	27.70	10.49	38.19	60.00	21.81	
	AV	0.152	31.09	10.59	41.68	55.88	14.20
		0.380	23.60	10.43	34.03	48.28	14.25
		0.824	17.20	10.38	27.58	46.00	18.42
		1.379	16.90	10.39	27.29	46.00	18.71
		3.313	19.40	10.45	29.85	46.00	16.15
		9.787	19.20	10.49	29.69	50.00	20.31
Neutral	0.151	40.79	10.59	51.38	65.95	14.57	QP
	0.372	33.19	10.42	43.61	58.47	14.86	
	0.559	33.40	10.36	43.76	56.00	12.24	
	1.535	30.80	10.39	41.19	56.00	14.81	
	3.418	34.29	10.45	44.74	56.00	11.26	
	9.575	29.09	10.56	39.65	60.00	20.35	
	AV	0.151	30.39	10.59	40.98	55.95	14.97
		0.372	22.09	10.42	32.51	48.47	15.96
		0.559	20.50	10.36	30.86	46.00	15.14
		1.535	21.50	10.39	31.89	46.00	14.11
		3.418	27.09	10.45	37.54	46.00	8.46
		9.575	20.39	10.56	30.95	50.00	19.05

TEST ENGINEER: SEVEN LU

EUT : LED LCD TV Temperature : 22°C
 Model No. : 40H5B Humidity : 48%RH
 Test Mode : USB Play Date of Test : Mar 08, 2016

Test Line	Frequency (MHz)	Meter Reading dB(μ V)	Factor (dB)	Emission Level dB(μ V)	Limits dB(μ V)	Margin (dB)	Remark	
Line	0.150	42.40	10.59	52.99	65.98	12.99	QP	
	0.366	33.89	10.44	44.33	58.60	14.27		
	0.629	28.30	10.38	38.68	56.00	17.32		
	1.519	24.60	10.40	35.00	56.00	21.00		
	3.483	27.70	10.45	38.15	56.00	17.85		
	9.472	26.50	10.49	36.99	60.00	23.01		
	Line	0.150	32.00	10.59	42.59	55.98	13.39	AV
		0.366	23.79	10.44	34.23	48.60	14.37	
		0.629	22.40	10.38	32.78	46.00	13.22	
		1.519	16.70	10.40	27.10	46.00	18.90	
3.483		18.60	10.45	29.05	46.00	16.95		
9.472		18.70	10.49	29.19	50.00	20.81		
Neutral	0.151	40.89	10.59	51.48	65.96	14.48	QP	
	0.380	34.40	10.41	44.81	58.27	13.46		
	0.578	34.00	10.36	44.36	56.00	11.64		
	2.022	31.30	10.41	41.71	56.00	14.29		
	3.412	34.79	10.45	45.24	56.00	10.76		
	9.359	28.59	10.56	39.15	60.00	20.85		
	Neutral	0.151	30.49	10.59	41.08	55.96	14.88	AV
		0.380	23.60	10.41	34.01	48.27	14.26	
		0.578	19.30	10.36	29.66	46.00	16.34	
		2.022	23.20	10.41	33.61	46.00	12.39	
3.412		26.89	10.45	37.34	46.00	8.66		
Neutral	9.359	20.69	10.56	31.25	50.00	18.75		

TEST ENGINEER: SEVEN LU

EUT : LED LCD TV Temperature : 22°C
 Model No. : 40H5B Humidity : 48%RH
 Test Mode : LAN Play Date of Test : Mar 08, 2016

Test Line	Frequency (MHz)	Meter Reading dB(μ V)	Factor (dB)	Emission Level dB(μ V)	Limits dB(μ V)	Margin (dB)	Remark
Line	0.152	42.09	10.59	52.68	65.91	13.23	QP
	0.344	34.19	10.45	44.64	59.10	14.46	
	0.616	27.50	10.38	37.88	56.00	18.12	
	1.364	24.80	10.39	35.19	56.00	20.81	
	3.286	27.40	10.45	37.85	56.00	18.15	
	9.779	27.40	10.49	37.89	60.00	22.11	
	AV	0.152	31.59	10.59	42.18	55.91	13.73
		0.344	25.09	10.45	35.54	49.10	13.56
		0.616	15.30	10.38	25.68	46.00	20.32
		1.364	16.10	10.39	26.49	46.00	19.51
		3.286	19.80	10.45	30.25	46.00	15.75
		9.779	18.70	10.49	29.19	50.00	20.81
Neutral	0.152	40.49	10.59	51.08	65.87	14.79	QP
	0.384	34.60	10.41	45.01	58.20	13.19	
	0.688	31.41	10.35	41.76	56.00	14.24	
	1.994	31.70	10.41	42.11	56.00	13.89	
	3.427	35.40	10.45	45.85	56.00	10.15	
	9.647	29.20	10.56	39.76	60.00	20.24	
	AV	0.152	29.69	10.59	40.28	55.87	15.59
		0.384	24.00	10.41	34.41	48.20	13.79
		0.688	22.11	10.35	32.46	46.00	13.54
		1.994	23.00	10.41	33.41	46.00	12.59
		3.427	27.50	10.45	37.95	46.00	8.05
		9.647	20.30	10.56	30.86	50.00	19.14

TEST ENGINEER: SEVEN LU

4 RADIATED EMISSION TEST

4.1 Test Equipment

The following test equipments are used during the radiated emission test in a semi-anechoic chamber:

Item	Type	Manufacturer	Model No.	Serial No.	Last Cal.	Next Cal.
1.	Test Receiver	R&S	ESCI	101303	May 07, 2016	May 06, 2017
2.	Preamplifier	Agilent	8447D	2944A06664	Apr 27, 2016	Apr 26, 2017
3.	Preamplifier	HP	8449B	3008A00864	Mar 20, 2016	Sep 19, 2017
4.	Bi-log Antenna	TESEQ	CBL6112D	23193	May 15, 2016	May 14, 2017
5.	Horn Antenna	EMCO	3115	9607-4878	Jun 03, 2015	Jun 02, 2016
6.	Spectrum	Agilent	E7405A	MY45106600	Feb 26, 2016	Feb 25, 2017
7.	Spectrum	HP	8591EM	3628A00908	May 07, 2016	May 06, 2017
8.	50Ω Coaxial Switch	Anritsu	MP59B	6200426390	Sep 18, 2016	Mar 17, 2017
9.	Software	Audix	e3	6.2007-9-10	--	--

4.2 Block Diagram of Test Setup

4.2.1 EUT & Peripherals

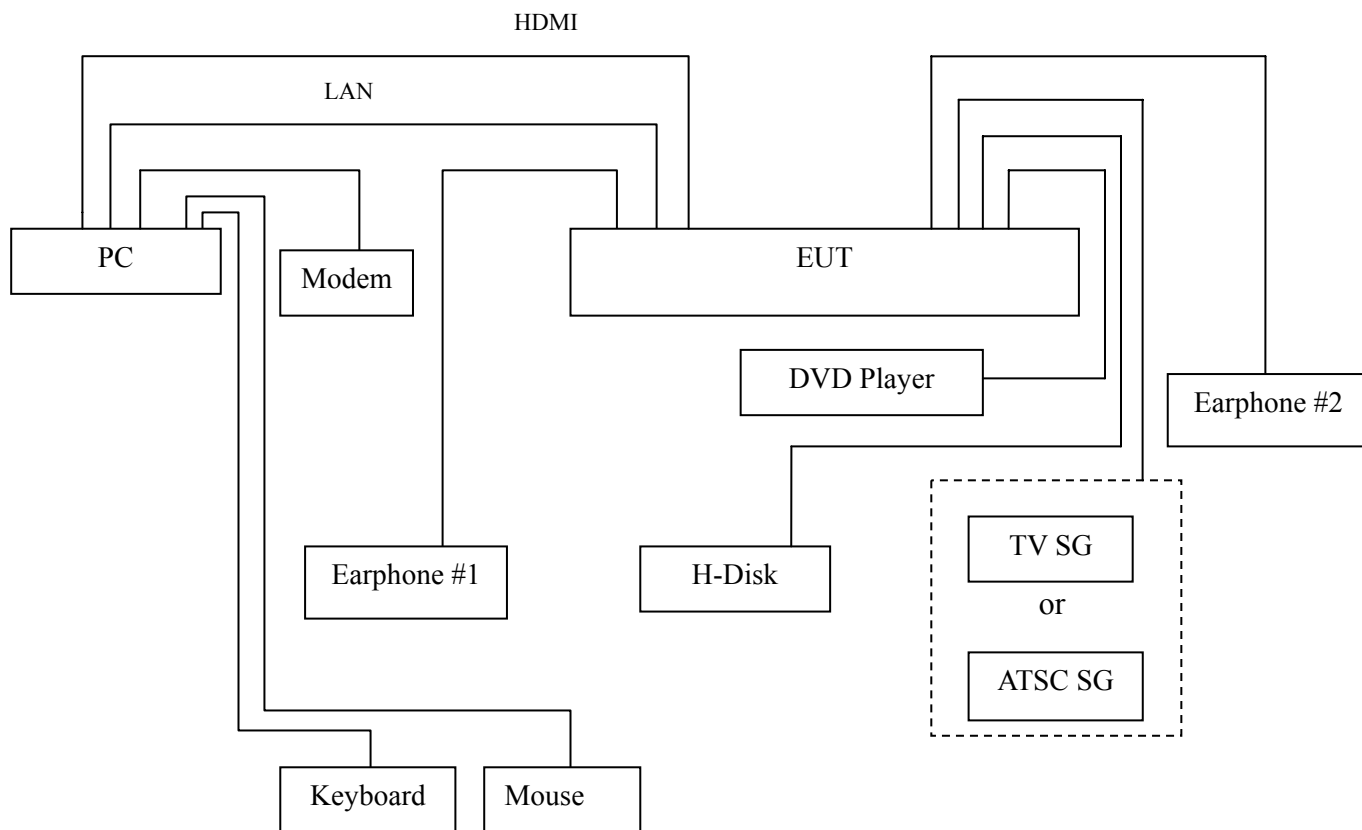

4.2.2 Test Setup

4.2.2.1 Below 1GHz

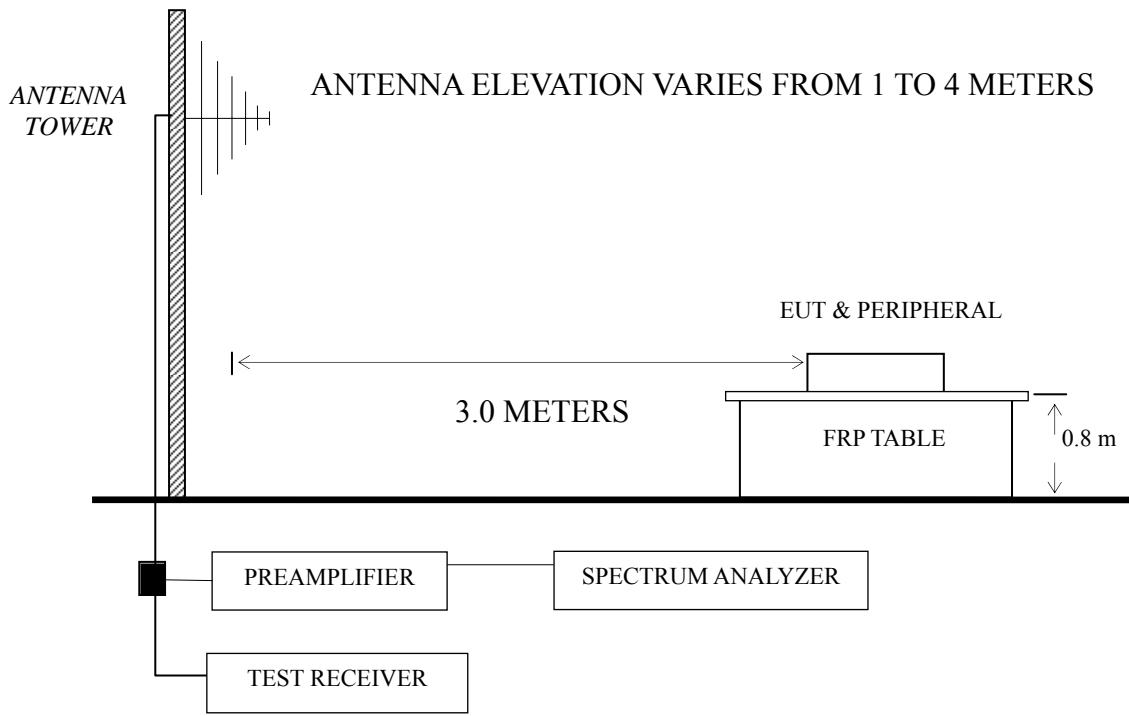

■ : 50 ohm Coaxial Switch

4.2.2.2 Above 1GHz

BORE-SIGHT ANTENNA TOWER

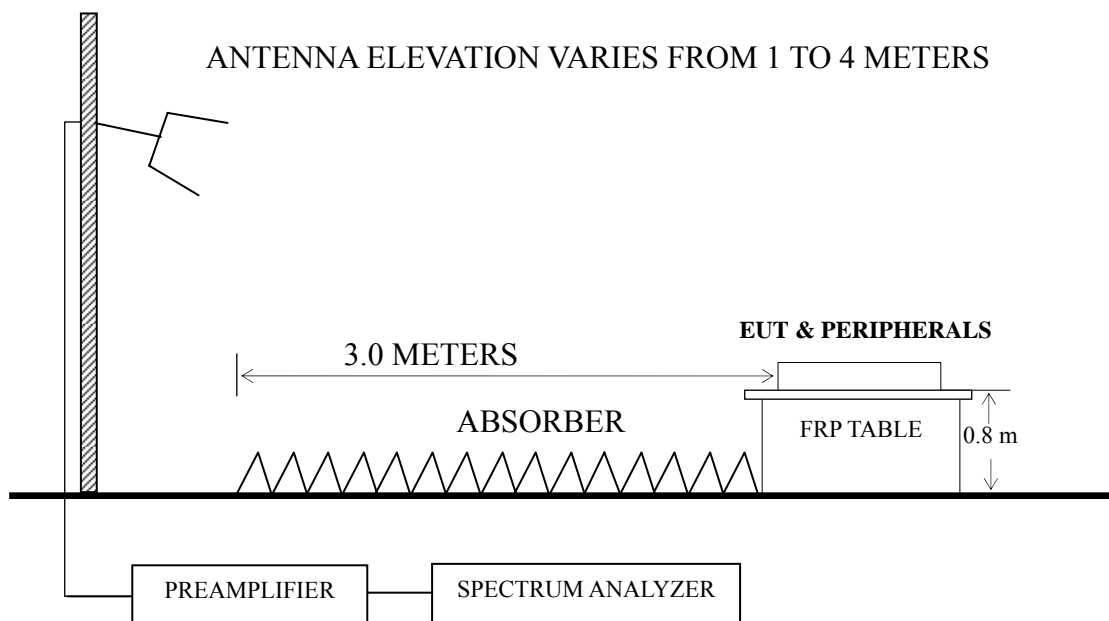

4.3 Radiated Emission Limit [FCC Part 15 Subpart B 15.109(a)]

Frequency (MHz)	Distance (m)	Field strength limits	
		($\mu\text{V}/\text{m}$)	dB ($\mu\text{V}/\text{m}$)
30 ~ 88	3	100	40.0
88 ~ 216	3	150	43.5
216 ~ 960	3	200	46.0
Above 960	3	500	54.0

NOTE 1 - Emission Level dB ($\mu\text{V}/\text{m}$) = 20 log Emission Level ($\mu\text{V}/\text{m}$)
 NOTE 2 - The tighter limit applies at the band edges.
 NOTE 3 - Distance refers to the distance in meters between the measuring instrument antenna and the closed point of any part of the device or system.
 NOTE 4 - The limits shown are based on Quasi-peak value detector.
 NOTE 5 - Above 1 GHz, the limit on peak emission is 20 dB above the maximum permitted average emission limit applicable to the EUT.

4.4 Test Configuration

The configuration of the EUT and peripherals are same as those used in conducted emission test.

Please refer to Sec.3.4.

4.5 Operating Condition of EUT

Same as conducted emission test which is listed in Sec.3.5, except for the test setup replaced by Sec.4.2.

4.6 Test Procedures

The EUT and peripherals were placed on a FRP turntable that is 0.8 meter above ground. The FRP turntable rotated 360 degrees to determine the position of the maximum emission level. The EUT was set 3 meters away from the receiving antenna, which was mounted on an antenna tower. Broadband antenna (Calibrated Bilog Antenna) was used as receiving antenna. The antenna moved up and down between 1 meter and 4 meters to find out the maximum emission level. Both horizontal and vertical polarizations of the antenna were set on measurement. In order to find the maximum emission, all of the interference cables were manipulated according to ANSI C63.4:2014 requirements during radiated emission test.

The I.F. bandwidth of Test Receiver R&S ESCI was set at 120 kHz.

The frequency range from 30 MHz to 1000MHz was checked for all test modes.

The frequency range from 1 GHz to 2 GHz was checked for the maximum resolution test mode.

The test modes were done on radiated disturbance test and all the test results are listed in Sec.4.7.

4.7 Test Results

<PASS>

The frequency and amplitude of the highest radiated emission relative the limit is reported. All the emissions not reported below are too low against the FCC limit.

Test Mode	Data Page
HDMI 1920*1080@60Hz & 1kHz playing	P23 - P24
HDMI 1280*1024@60Hz & 1kHz playing	P25
HDMI 640*480@60Hz & 1kHz playing	P26
HDMI1080P	P27
USB Play	P28
LAN Play	P29

NOTE 1 – Emission Level = Antenna Factor + Cable Loss + Meter Reading.
($< 1\text{GHz}$);

Emission Level = Antenna Factor + Cable Loss – Preamp Factor
+ Meter Reading. ($> 1\text{GHz}$)

NOTE 2 – All readings are Quasi-Peak values below or equal to 1GHz, Peak and Average values above 1GHz.

NOTE 3 – 0° was the table front facing the antenna. Degree is calculated from 0° clockwise facing the antenna.

NOTE 4 – The worst case is for HDMI 1920*1080@60Hz & 1kHz playing test mode. The worst emission at horizontal polarization was detected at 742.259 MHz with corrected signal level of 42.88 dB ($\mu\text{V/m}$) (limit is 46.00 dB ($\mu\text{V/m}$)), when the antenna was 1.6 m height and the turntable was at 225° . The worst emission at vertical polarization was detected at 719.200 MHz with corrected signal level of 42.63dB ($\mu\text{V/m}$) (limit is 46.00 dB ($\mu\text{V/m}$)), when the antenna was 1.1m height and the turntable was at 70° .

EUT : LED LCD TV Temperature : 22°C

Model No. : 40H5B Humidity : 60%RH

Test Mode : HDMI 1920*1080@60Hz & 1kHz Playing Date of Test : May 18, 2016

Polarization	Frequency (MHz)	Meter Reading dB (μV)	Antenna Factor (dB/m)	Cable Loss (dB)	Preamp Factor (dB)	Emission Level dB (μV/m)	Limits dB (μV/m)	Margin (dB)	Remark
Horizontal	134.559	22.00	12.62	1.55	--	36.17	43.50	7.33	QP
	213.763	24.69	10.17	2.02	--	36.88	43.50	6.62	
	237.476	27.86	11.64	2.11	--	41.61	46.00	4.39	
	428.019	19.03	16.80	2.78	--	38.61	46.00	7.39	
	742.259	19.31	19.97	3.60	--	42.88	46.00	3.12	
	796.183	18.17	20.57	3.68	--	42.42	46.00	3.58	PK
	1196.649	49.65	24.43	3.52	36.14	41.46	74.00	32.54	
	1632.406	50.48	26.17	4.04	35.51	45.18	74.00	28.82	
	1889.494	44.73	27.12	4.31	35.22	40.94	74.00	33.06	AV
	1196.649	34.29	24.43	3.52	36.14	26.10	54.00	27.90	
1632.406	36.28	26.17	4.04	35.51	30.98	54.00	23.02		
1889.494	29.03	27.12	4.31	35.22	25.24	54.00	28.76		

TEST ENGINEER: BILL WU

EUT : LED LCD TV Temperature : 22°C

Model No. : 40H5B Humidity : 60%RH

Test Mode : HDMI 1920*1080@60Hz Date of Test : May 18, 2016
& 1kHz Playing

Polarization	Frequency (MHz)	Meter Reading dB (μV)	Antenna Factor (dB/m)	Cable Loss (dB)	Preamp Factor (dB)	Emission Level dB (μV/m)	Limits dB (μV/m)	Margin (dB)	Remark
Vertical	32.067	16.41	17.43	0.66	--	34.50	40.00	5.50	QP
	97.456	23.34	12.02	1.29	--	36.65	43.50	6.85	
	148.963	22.28	11.57	1.63	--	35.48	43.50	8.02	
	239.987	23.73	11.80	2.11	--	37.64	46.00	8.36	
	446.414	19.22	16.83	2.82	--	38.87	46.00	7.13	
	719.200	19.18	19.88	3.57	--	42.63	46.00	3.37	PK
	1185.000	64.83	24.39	3.63	36.16	56.69	74.00	17.31	
	1355.664	56.35	25.08	3.72	35.89	49.26	74.00	24.74	
	1991.699	57.36	27.46	4.43	35.11	54.14	74.00	19.86	
	1185.000	43.01	24.39	3.63	36.16	34.87	54.00	19.13	
	AV	1355.664	42.52	25.08	3.72	35.89	35.43	54.00	18.57
1991.699		43.63	27.46	4.43	35.11	40.41	54.00	13.59	

TEST ENGINEER: BILL WU

EUT : LED LCD TV Temperature : 22°C

Model No. : 40H5B Humidity : 60%RH

Test Mode : HDMI 1280*1024@60Hz & 1kHz Playing Date of Test : May 18, 2016

Polarization	Frequency (MHz)	Meter Reading dB (μV)	Antenna Factor (dB/m)	Cable Loss (dB)	Emission Level dB (μV/m)	Limits dB (μV/m)	Margin (dB)
Horizontal	110.182	22.67	12.61	1.40	36.68	43.50	6.82
	245.951	27.26	12.34	2.14	41.74	46.00	4.26
	432.546	21.60	16.82	2.79	41.21	46.00	4.79
	647.386	18.83	19.70	2.90	41.43	46.00	4.57
	714.173	16.31	19.85	3.57	39.73	46.00	6.27
	790.619	16.55	20.50	3.68	40.73	46.00	5.27
Vertical	32.293	15.46	17.28	0.66	33.40	40.00	6.60
	108.267	23.98	12.57	1.39	37.94	43.50	5.56
	245.951	23.82	12.34	2.14	38.30	46.00	7.70
	399.030	17.68	16.58	2.71	36.97	46.00	9.03
	432.546	21.66	16.82	2.79	41.27	46.00	4.73
	719.200	16.49	19.88	3.57	39.94	46.00	6.06

TEST ENGINEER: BILL WU

EUT : LED LCD TV Temperature : 22°C

Model No. : 40H5B Humidity : 60%RH

Test Mode : HDMI 640*480@60Hz & 1kHz Playing Date of Test : May 18, 2016

Polarization	Frequency (MHz)	Meter Reading dB (μV)	Antenna Factor (dB/m)	Cable Loss (dB)	Emission Level dB (μV/m)	Limits dB (μV/m)	Margin (dB)
Horizontal	99.878	19.90	12.25	1.32	33.47	43.50	10.03
	174.424	17.89	10.73	1.80	30.42	43.50	13.08
	296.184	17.81	13.65	2.56	34.02	46.00	11.98
	480.528	15.86	17.50	2.90	36.26	46.00	9.74
	699.305	11.23	19.80	3.54	34.57	46.00	11.43
	830.400	13.72	20.70	3.97	38.39	46.00	7.61
Vertical	32.634	16.98	17.13	0.66	34.77	40.00	5.23
	95.762	22.67	11.79	1.27	35.73	43.50	7.77
	114.917	22.79	12.70	1.43	36.92	43.50	6.58
	243.377	25.79	12.10	2.13	40.02	46.00	5.98
	396.242	18.73	16.57	2.71	38.01	46.00	7.99
	721.726	17.97	19.90	3.57	41.44	46.00	4.56

TEST ENGINEER: BILL WU

EUT : LED LCD TV Temperature : 22°C
 Model No. : 40H5B Humidity : 60%RH
 Test Mode : HDMI1080P Date of Test : May 18, 2016

Polarization	Frequency (MHz)	Meter Reading dB (μV)	Antenna Factor (dB/m)	Cable Loss (dB)	Emission Level dB (μV/m)	Limits dB (μV/m)	Margin (dB)
Horizontal	121.123	20.41	12.86	1.46	34.73	43.50	8.77
	164.908	24.83	11.30	1.75	37.88	43.50	5.62
	243.377	27.01	12.10	2.13	41.24	46.00	4.76
	719.200	17.45	19.88	3.57	40.90	46.00	5.10
	790.619	16.85	20.50	3.68	41.03	46.00	4.97
	890.728	13.45	21.30	4.46	39.21	46.00	6.79
Vertical	30.853	15.71	18.25	0.64	34.60	40.00	5.40
	99.180	24.50	12.21	1.32	38.03	43.50	5.47
	197.200	22.19	9.97	1.95	34.11	43.50	9.39
	243.377	24.95	12.10	2.13	39.18	46.00	6.82
	396.242	15.32	16.57	2.71	34.60	46.00	11.40
	716.682	18.48	19.88	3.57	41.93	46.00	4.07

TEST ENGINEER: BILL WU

EUT : LED LCD TV Temperature : 22°C

Model No. : 40H5B Humidity : 60%RH

Test Mode : USB Play Date of Test : May 18, 2016

Polarization	Frequency (MHz)	Meter Reading dB (μ V)	Antenna Factor (dB/m)	Cable Loss (dB)	Emission Level dB (μ V/m)	Limits dB (μ V/m)	Margin (dB)
Horizontal	101.289	20.03	12.35	1.33	33.71	43.50	9.79
	144.335	20.56	12.15	1.60	34.31	43.50	9.19
	201.393	21.04	9.72	1.97	32.73	43.50	10.77
	250.301	22.50	12.50	2.15	37.15	46.00	8.85
	302.481	18.64	13.88	2.59	35.11	46.00	10.89
	506.479	14.40	17.90	2.89	35.19	46.00	10.81
Vertical	33.680	15.11	16.55	0.67	32.33	40.00	7.67
	111.347	21.91	12.63	1.40	35.94	43.50	7.56
	195.822	22.50	10.03	1.94	34.47	43.50	9.03
	282.985	17.29	13.35	2.45	33.09	46.00	12.91
	549.020	13.27	18.74	2.63	34.64	46.00	11.36
	845.088	11.21	20.73	4.07	36.01	46.00	9.99

TEST ENGINEER: BILL WU

EUT : LED LCD TV Temperature : 22°C

Model No. : 40H5B Humidity : 60%RH

Test Mode : LAN Play Date of Test : May 18, 2016

Polarization	Frequency (MHz)	Meter Reading dB (μ V)	Antenna Factor (dB/m)	Cable Loss (dB)	Emission Level dB (μ V/m)	Limits dB (μ V/m)	Margin (dB)
Horizontal	107.888	19.73	12.56	1.38	33.67	43.50	9.83
	184.490	20.49	10.50	1.87	32.86	43.50	10.64
	269.428	21.58	13.30	2.32	37.20	46.00	8.80
	392.095	18.12	16.52	2.71	37.35	46.00	8.65
	520.888	14.58	18.14	2.78	35.50	46.00	10.50
	851.035	11.51	20.73	4.17	36.41	46.00	9.59
Vertical	38.078	18.04	13.18	0.72	31.94	40.00	8.06
	126.329	19.30	13.03	1.50	33.83	43.50	9.67
	183.201	19.48	10.50	1.87	31.85	43.50	11.65
	259.234	19.06	13.00	2.25	34.31	46.00	11.69
	429.523	15.32	16.80	2.79	34.91	46.00	11.09
	645.120	12.51	19.70	2.90	35.11	46.00	10.89

TEST ENGINEER: BILL WU

5 DEBUG DESCRIPTION

The following components are used during the countermeasure procedures:

Name	M/N	Manufacturer	Location
Conductive foam	SMR-TSL-4-3.5-5R	JOINSET	See Appendix Figure 17

Note: We had required the applicant and manufacturer that all electrical and mechanical devices employed for spurious radiation suppression, including any modifications made during certification testing, must be incorporated in each unit marked

TEST ENGINEER:



(BYRON WU)

6 DEVIATION TO TEST SPECIFICATIONS

None.

