

Application for FCC Certificate

On Behalf of

Hisense Electric Co., Ltd.

LED Backlight TV

FCC ID:W9HLCDD0056

Prepared for : Hisense Electric Co., Ltd.
Address : No.218 Qianwangang Road, Economy &
Technology Development Zone, Qingdao, China

Prepared by : EST Technology Co., Ltd.
Address : Chilingxiang, Qishantou, Santun, Houjie, Dongguan,
Guangdong, China

Tel: 86-769-83081888

Fax: 86-769-83081878

Report No. : ESTE-F1601039



Date of Report : Jan. 27, 2016

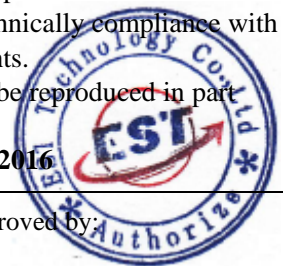

TABLE OF CONTENTS

	Page
Test Report Declaration	
1. GENERAL PRODUCT INFORMATION	4
1.1. Product Function	4
1.2. Difference between Model Numbers	4
1.3. Independent Operation Modes	4
2. TEST SITES	5
2.1. Description of Standards and Results.....	5
2.2. Test Facilities	6
2.3. List of Test and Measurement Instruments	7
3. TEST SET-UP AND OPERATION MODES	8
3.1. Principle of Configuration Selection.....	8
3.2. Block Diagram of Test Set-up.....	8
3.3. Test Operation Mode and Test Software.....	9
3.4. Special Accessories and Auxiliary Equipment	9
3.5. Countermeasures to Achieve EMC Compliance.....	9
4. EMISSION TEST RESULTS	10
4.1. Conducted Emission at the Mains Terminals Test.....	10
4.2. Radiated Emission Test.....	13
5. PHOTOGRAPHS OF TEST SET-UP	19
5.1. Set-up for conducted emission at the mains terminals test.....	19
5.2. Set-up for radiated emission test (30-1000MHz)	20
5.3. Set-up for radiated emission test (Above 1GHz)	21
6. PHOTOGRAPHS OF THE EUT	22

EST Technology Co., Ltd.

Applicant:	Hisense Electric Co., Ltd.		
Address:	No.218 Qianwangang Road, Economy & Technology Development Zone, Qingdao, China		
Manufacturer	Guangdong Hisense Electronics Co., Ltd		
Address:	Zone B, No. 8 Hisense Road, Advanced Manufacturing Jiangsha Demonstration Park, Jiangmen City, Guangdong Province 529000, China		
Factory 1:	Tatung Mexico S.A. de C.V.		
Address:	Miguel Catalán 420, Parque Industrial Rio Bravo, Cd. Juarez, Chih, Mexico		
Factory 2:	Guangdong Hisense Electronics Co., Ltd		
Address:	Zone B, No. 8 Hisense Road, Advanced Manufacturing Jiangsha Demonstration Park, Jiangmen City, Guangdong Province 529000, China		
Factory 3:	HISENSE ELECTRONICA MEXICO, S.A. DE C.V.		
Address:	Blvd. Sharp #3510 Parque Industrial Rosarito, C.P. 22710 Playas de Rosarito, Baja California, Mexico		
Factory 4:	Hisense Electric Co., Ltd		
Address:	No. 218 Qianwangang Road, Economy & Technology Development Zone, Qingdao 266071		
E.U.T:	LED Backlight TV		
Model Number:	HU40M2160F		
Additional Model:	40M2160, 40H3C, 40H3C+ ("+ " can be 0-9, represent the different sales purposes; only the model different)		
Trade Name:	Hisense	Serial No.:	-----
Date of Receipt:	Jan. 15, 2016	Date of Test:	Jan. 15, - 26, 2016
Test Specification:	FCC Rules and Regulations Part 15 Subpart B:2015 ANSI C63.4:2014		
Test Result:	<p>The device described above is tested by EST Technology Co., Ltd.. The measurement results were contained in this test report and EST Technology Co., Ltd. was assumed full responsibility for the accuracy and completeness of these measurements. Also, this report shows that the EUT to be technically compliance with the FCC Rules and Regulations Part 15 Subpart B requirements. This report applies to above tested sample only and shall not be reproduced in part without written approval of EST Technology Co., Ltd.</p> <p style="text-align: right;">Issue Date: Jan. 27, 2016</p>		
Prepared by:	Tested by:	Approved by:	
			
_____ Amy / Assistant	_____ Bible / Engineer	_____ Iceman Hu / Manager	
Other Aspects:	None.		
<i>Abbreviations: OK/P=passed fail/F=failed n.a/N=not applicable E.U.T=equipment under tested</i>			



1. GENERAL PRODUCT INFORMATION

1.1. Product Function

Refer to Technical Construction Form and User Manual.

1.2. Difference between Model Numbers

Note: The Product only different model number,
But the PCB board inside are identical.

1.3. Independent Operation Modes

1.3.1. Conducted Modes

1	VGA Mode(1024*768+Running "H" Pattern)	Worst case
2	VGA Mode(800*600+Running "H" Pattern)	
3	VGA Mode(640*480+Running "H" Pattern)	
4	HDMI(1024*768+Running "H" Pattern)	
5	HDMI(800*600+Running "H" Pattern)	
6	HDMI(640*480+Running "H" Pattern)	
Note: The worst case will be recorded in this report.		

1.3.2. Radiated Modes

30MHz~1GHz		
1	VGA Mode(1024*768+Running "H" Pattern)	Worst case
2	VGA Mode(800*600+Running "H" Pattern)	
3	VGA Mode(640*480+Running "H" Pattern)	
4	HDMI(1024*768+Running "H" Pattern)	
5	HDMI(800*600+Running "H" Pattern)	
6	HDMI(640*480+Running "H" Pattern)	
Above 1GHz		
1	VGA Mode(1024*768+Running "H" Pattern)	Worst case
2	VGA Mode(800*600+Running "H" Pattern)	
3	VGA Mode(640*480+Running "H" Pattern)	
4	HDMI(1024*768+Running "H" Pattern)	
5	HDMI(800*600+Running "H" Pattern)	
6	HDMI(640*480+Running "H" Pattern)	
Note: The worst case will be recorded in this report.		

2. TEST SITES

2.1. Description of Standards and Results

The EUT have been tested according to the applicable standards as referenced below

EMISSION			
Description of Test Item	Standard	Limits	Results
Conducted disturbance at mains terminals	FCC Rules and Regulations Part 15 Subpart B:2015 ANSI C63.4:2014	15.107(a) Class B	PASS
		Minimum passing margin is 1.90dB at 0.305MHz	
Radiated Emission Test	FCC Rules and Regulations Part 15 Subpart B:2015 ANSI C63.4:2014	15.109(a) Class B	PASS
		Minimum passing margin is 11.83dB at 291.90MHz for 30-1000MHz; Minimum passing margin is 12.67dB at 5975MHz for above 1GHZ;	

2.2. Test Facilities

EMC Lab : Certificated by CNAS, CHINA
 Registration No.: L5288
 Date of registration: December 07, 2015

 Certificated by FCC, USA
 Registration No.: 989591
 Date of registration: November 20, 2013

 Certificated by Industry Canada
 Registration No.: 9405A-1
 Date of registration: December 30, 2015

 Certificated by VCCI, Japan
 Registration No.: R-3663 & C-4103
 Date of registration: July 25, 2014

 Certificated by TUV Rheinland, Germany
 Registration No.: UA 50195514 0001
 Date of registration: January 07, 2011

 Certificated by TUV/PS, Shenzhen
 Registration No.: SCN1017
 Date of registration: January 27, 2011

 Certificated by Intertek ETL SEMKO
 Registration No.: 2011-RTL-L1-18
 Date of registration: April 28, 2011

 Certificated by Nemko, Hong Kong
 Registration No.: 175193
 Date of registration: May 4, 2011

Name of Firm : EST Technology Co., Ltd.

Site Location : Chilingxiang, Qishantou, Santun, Houjie, Dongguan,
 Guangdong, China

2.3. List of Test and Measurement Instruments

2.3.1. For conducted emission at the mains terminals test (844 Room)

Equipment	Manufacturer	Model No.	Serial No.	Last Cal.	Next Cal.
EMI Test Receiver	Rohde& Schwarz	ESVS30	832354	June 28,15	1 Year
Artificial Mains Network	Rohde& Schwarz	ENV216	101260	June 28,15	1 Year
Pulse Limiter	Rohde& Schwarz	ESH3-Z2	101100	June 28,15	1 Year

2.3.2. For radiated emission test

Equipment	Manufacturer	Model No.	Serial No.	Last Cal.	Next Cal.
EMI Test Receiver	Rohde& Schwarz	ESVS10	100004	June 28,15	1 Year
Spectrum Analyzer	Agilent	E4411B	MY50140697	June 28,15	1 Year
Bilog Antenna	Teseq	CBL 6111D	25872	June 28,15	1 Year
Signal Amplifier	Agilent	310N	187037	June 28,15	1 Year
Horn Antenna	SCHWARZBECK	BBHA9120D	8128-290	June 28,15	1 Year
Signal Amplifier	SCHWARZBECK	BBV9718	9718-212	June 28,15	1 Year
Spectrum Analyzer	Agilent	E4408B	MY44211139	June 28,15	1 Year

3. TEST SET-UP AND OPERATION MODES

3.1. Principle of Configuration Selection

Emission: The equipment under test (EUT) was configured to measure its highest possible radiation level. The test modes were adapted accordingly in reference to the Operating Instructions.

3.2. Block Diagram of Test Set-up

System Diagram of Connections between EUT and Simulators

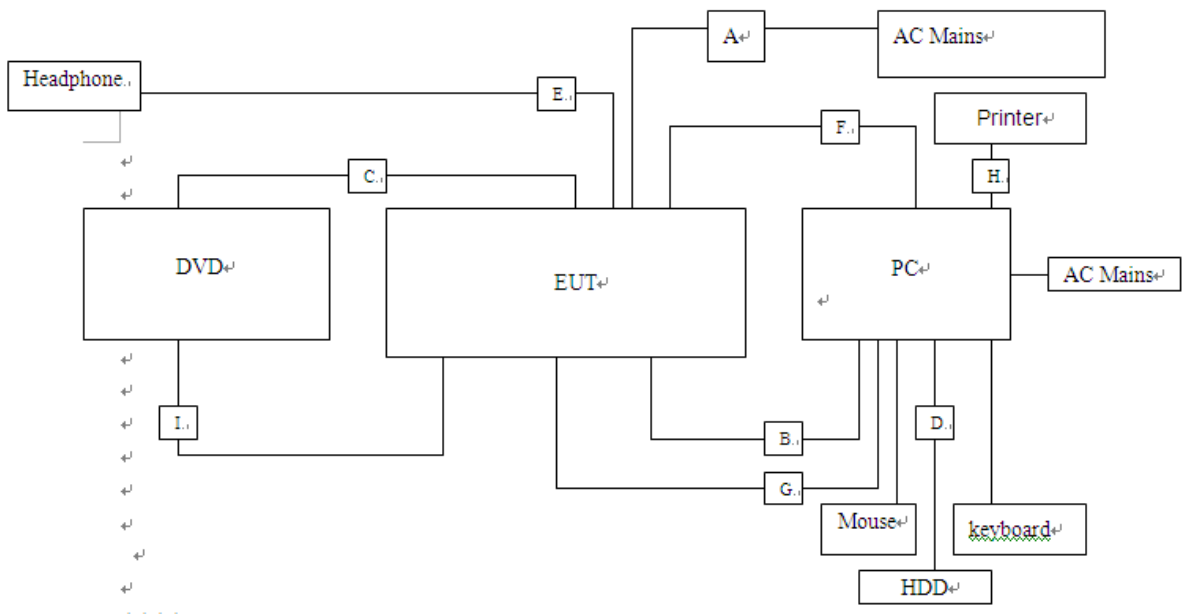

(EUT: LED Backlight TV)

A	AC Line	Unshielded, Detachable 1.5m
B	HDMI	Unshielded, Detachable 1.2m
G	PC AUDIO IN	Unshielded, Detachable 1.2m
I	Y+Pb+Pr	Unshielded, Detachable 1.2m
E	Headphone	Unshielded, Detachable 1.2m
F	VGA	Unshielded, Detachable 1.2m
H	USB Cabel	Unshielded, Detachable 1.4m
D	USB Cabel	Unshielded, Detachable 0.8m
C	HDMI	Unshielded, Detachable 1.2m

3.3. Test Operation Mode and Test Software

Refer to Test Setup in clause 4.

3.4. Special Accessories and Auxiliary Equipment

3.4.1. PC

M / N : VOSTRO
Manufacturer : DELL
Power Cord : Unshielded, Detachable, 1.6m

3.4.2. DVD Player

M / N : DVDHDMI01
Manufacturer : SAMWIN
Data Cable : Shielded, Undetachable, 1.6m

3.4.3. HDD

Model Number : A1446
Serial Number : DCYJH84RF0GV
Manufacturer : iPod nano/Apple
Data Cable : Non-shielded, Detachable, 1.5m

3.4.4. Printer

M / N : HP1020
Manufacturer : HP
Data Cable : Non-shielded, Detachable, 1.5m

3.4.5. Mouse

M / N : MOL5VO
S / N : JOQ03RNT
Manufacturer : Dell
cable : Shielded, Undetachable, 1.5m

3.4.6. Keyboard

M / N : L100
S / N : CN-0RH656-65890-01M-070T
Manufacturer : Dell
cable : Shielded, Undetachable, 1.8m

3.5. Countermeasures to Achieve EMC Compliance

None.

4. EMISSION TEST RESULTS

4.1. Conducted Emission at the Mains Terminals Test

RESULT : **Pass**
Test Procedure : ANSI C63.4:2014
Frequency Range : 0.15 to 30MHz
Test Site : Shielded Room
Limits : FCC Part 15:2015 Class B

Test Setup

Date of Test : Jan. 18, 2016
M/N : HU40M2160F
Input Voltage : AC 120V/60Hz
Operation Mode : VGA Mode, HDMI

The frequency range from 150 kHz to 30 MHz was investigated.

The bandwidth of the test receiver was set at 9 kHz.

The test data of the worst case condition(s) was reported on the following page.

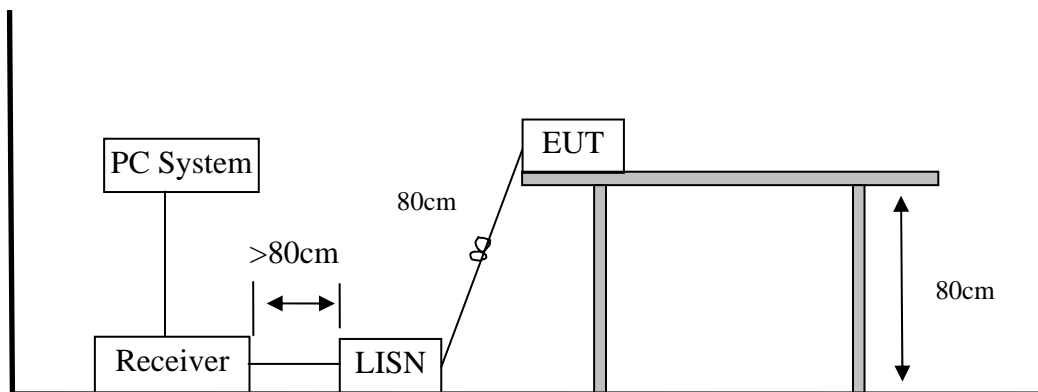

Note: Measurement Uncertainty: ± 2.54 dB at a level of confidence of 95%.

Test Data

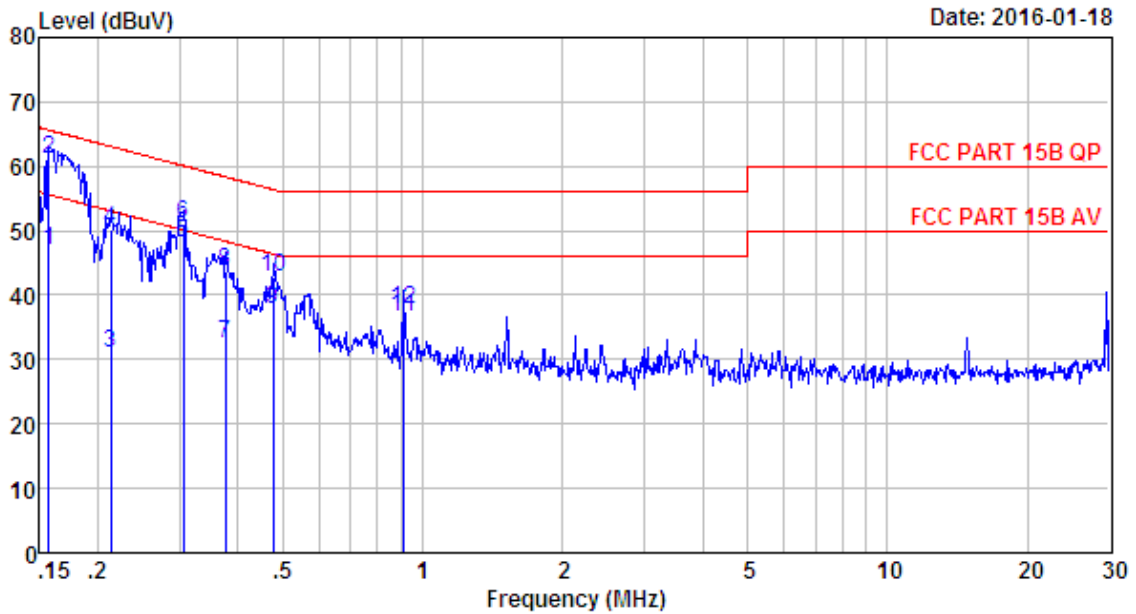

Site no : 844 Shield Room Data no. : 217
 Env. / Ins. : Temp:24.3°C Humi:58% Press:101.50kPa LINE Phase : NEUTRAL
 Limit : FCC PART 15B QP
 Engineer : Bible
 EUT : LED Backlight TV
 Power : AC 120V/60Hz
 M/N : HU40M2160F
 Test Mode : VGA Mode(1024*768+Running "H" Pattern)

	Freq. (MHz)	LISN Factor (db)	Cable Loss (db)	Reading dBuV)	Emission Level (dBuv)	Limits (dBuv)	Margin (dB)	Remark
1	0.156	9.48	9.81	27.71	47.00	55.65	8.65	Average
2	0.156	9.48	9.81	41.71	61.00	65.65	4.65	QP
3	0.213	9.60	9.80	11.74	31.14	53.10	21.96	Average
4	0.213	9.60	9.80	30.74	50.14	63.10	12.96	QP
5	0.305	9.60	9.83	28.77	48.20	50.10	1.90	Average
6	0.305	9.60	9.83	31.77	51.20	60.10	8.90	QP
7	0.377	9.59	9.82	13.16	32.57	48.34	15.77	Average
8	0.377	9.59	9.82	24.16	43.57	58.34	14.77	QP
9	0.476	9.59	9.81	18.51	37.91	46.41	8.50	Average
10	0.476	9.59	9.81	23.51	42.91	56.41	13.50	QP
11	0.909	9.62	9.82	17.20	36.64	46.00	9.36	Average
12	0.909	9.62	9.82	18.20	37.64	56.00	18.36	QP



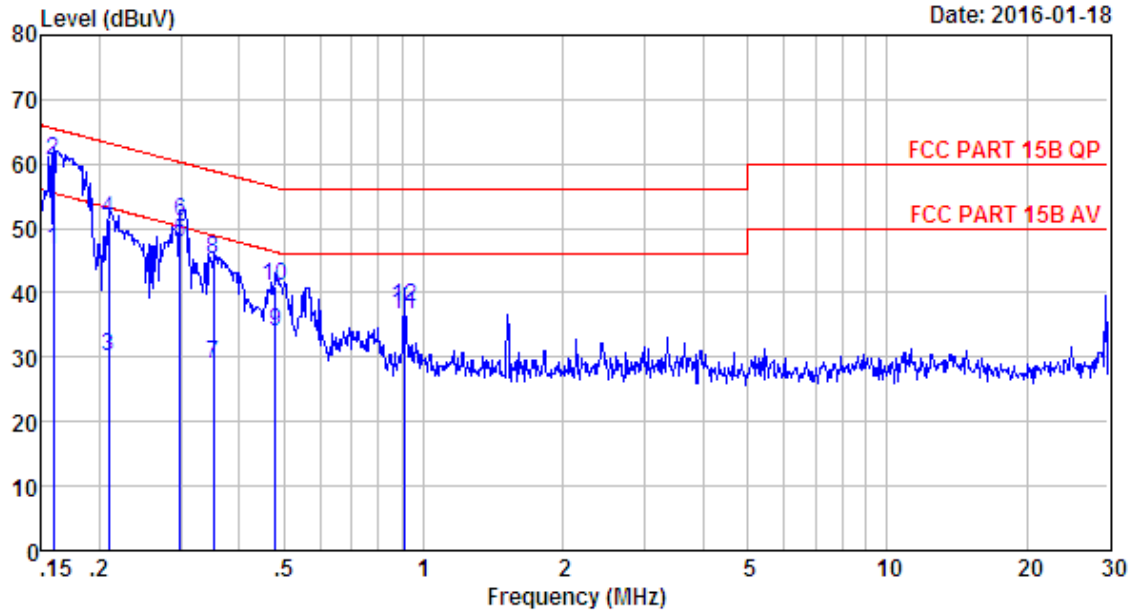

Site no : 844 Shield Room Data no. : 219
 Env. / Ins. : Temp:24.3'C Humi:58% Press:101.50kPa LINE Phase : LINE
 Limit : FCC PART 15B QP
 Engineer : Bible
 EUT : LED Backlight TV
 Power : AC 120V/60Hz
 M/N : HU40M2160F
 Test Mode : VGA Mode(1024*768+Running "H" Pattern)

	Freq. (MHz)	LISN Factor (db)	Cable Loss (db)	Reading dBuV)	Emission Level (dBuV)	Limits (dBuV)	Margin (dB)	Remark
1	0.159	9.61	9.81	27.20	46.62	55.52	8.90	Average
2	0.159	9.61	9.81	41.20	60.62	65.52	4.90	QP
3	0.209	9.61	9.80	10.81	30.22	53.23	23.01	Average
4	0.209	9.61	9.80	31.81	51.22	63.23	12.01	QP
5	0.299	9.61	9.83	28.52	47.96	50.28	2.32	Average
6	0.299	9.61	9.83	31.52	50.96	60.28	9.32	QP
7	0.352	9.61	9.83	9.61	29.05	48.91	19.86	Average
8	0.352	9.61	9.83	25.61	45.05	58.91	13.86	QP
9	0.479	9.61	9.81	14.65	34.07	46.36	12.29	Average
10	0.479	9.61	9.81	21.65	41.07	56.36	15.29	QP
11	0.909	9.63	9.82	17.25	36.70	46.00	9.30	Average
12	0.909	9.63	9.82	18.25	37.70	56.00	18.30	QP

4.2. Radiated Emission Test

RESULT : **Pass**
Test Procedure : ANSI C63.4:2014
Frequency Range : 30-1000 MHz;1-6 GHz
Test Site : 966 Chamber
Limits : FCC Part 15:2015 Class B

Test Setup

Date of Test : Jan. 18-20, 2016
M/N : HU40M2160F
Input Voltage : AC 120V/60Hz
Operation Mode : VGA Mode, HDMI

The EUT was placed on a turn table which was 0.8 m above the ground. The turn table can rotate 360 degrees to determine the position of the maximum emission level. The EUT was set 3 m away from the receiving antenna which was mounted on an antenna tower. The measuring antenna moved up and down to find out the maximum emission level. It moved from 1 m to 4 m for both horizontal and vertical polarizations.

The EUT was tested in the Chamber Site. It was pre-scanned with a Peak detector from the spectrum, and all the final readings from the test receiver were measured with the Quasi-Peak detector.

The bandwidth setting on the test receiver was 120 kHz.

The bandwidth of the Spectrum's VBW is set at 3MHz and RBW is set at 1MHz for peak emissions measurement above 1GHz and 1MHz RBW, 10Hz VBW for average emissions measure above 1GHz

The test data of the worst case condition(s) was reported on the following page.

1、 In Semi-anechoic Chamber Test Setup Diagram for 30MHz~1000MHz

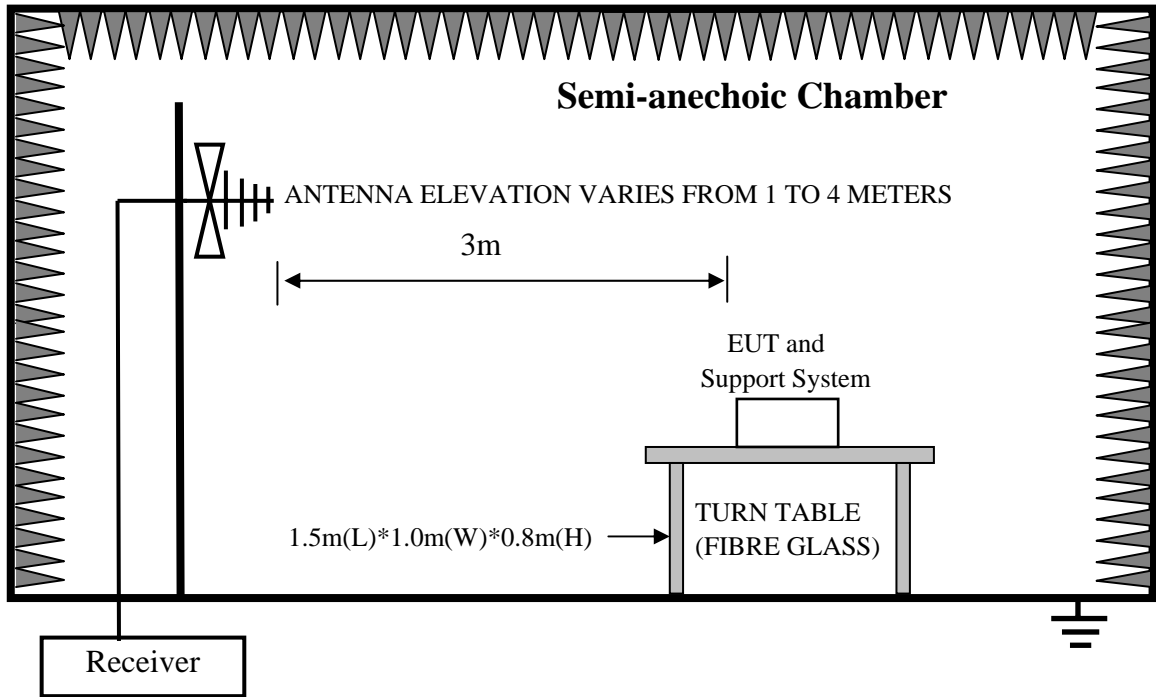

2、 In Anechoic Chamber Test Setup Diagram for 1-6GHz

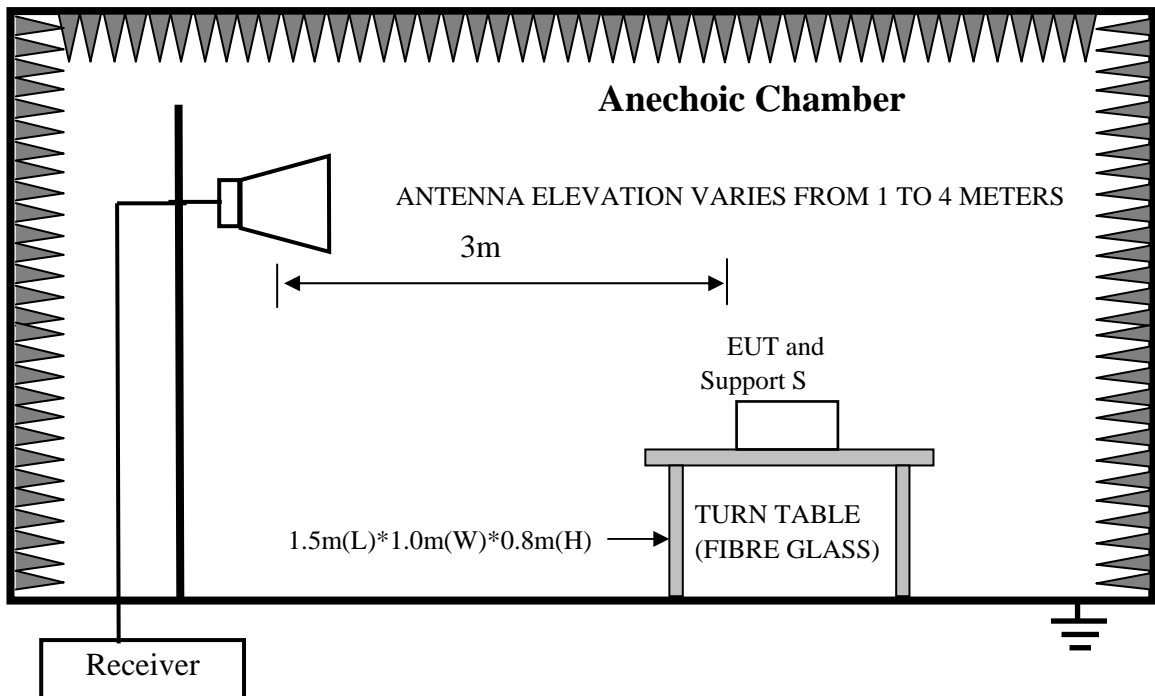

Test uncertainty: $\pm 3.62\text{dB}$ at a level of confidence of 95%.

Test Data

30MHz-1GHz

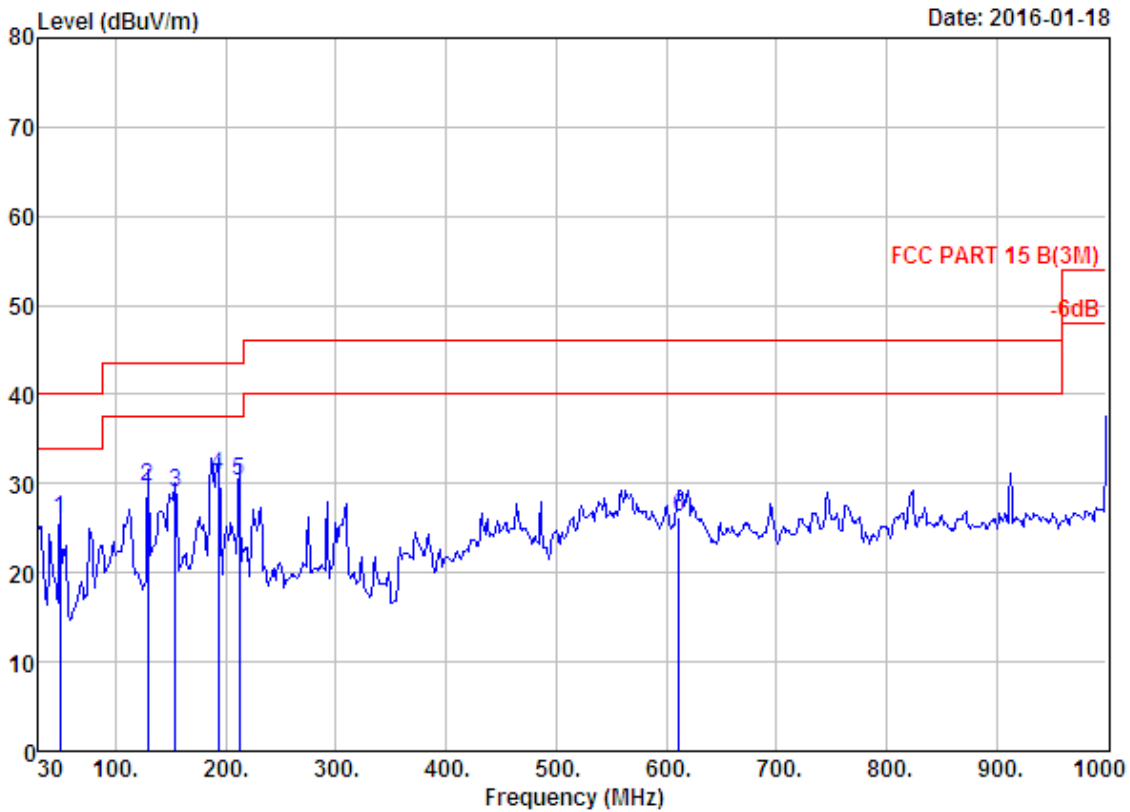

Site no. : 966 1# chamber Data no. : 115
 Dis. / Ant. : 3m 27137 Ant. pol. : VERTICAL
 Limit : FCC PART 15 B(3M)
 Env. / Ins. : Temp:23.6';Humi:56%;Press:101.52kPa
 Engineer : Dick
 EUT : LED Backlight TV
 Power : AC 120V/60Hz
 M/N : HU40M2160F
 Test Mode : VGA Mode(1024*768+Running "H" Pattern)

	Freq. (MHz)	Ant. Factor (dB/m)	Cable Loss (dB)	Reading (dBuV)	Emission Level (dBuV/m)	Limits (dBuV/m)	Margin (dB)	Remark
1	49.40	7.90	0.95	17.26	26.11	40.00	13.89	QP
2	128.94	11.33	1.47	16.77	29.57	43.50	13.93	QP
3	154.16	10.71	1.66	16.60	28.97	43.50	14.53	QP
4	192.96	7.85	1.77	21.25	30.87	43.50	12.63	QP
5	212.36	8.56	1.91	19.78	30.25	43.50	13.25	QP
6	612.00	19.91	3.33	3.05	26.29	46.00	19.71	QP



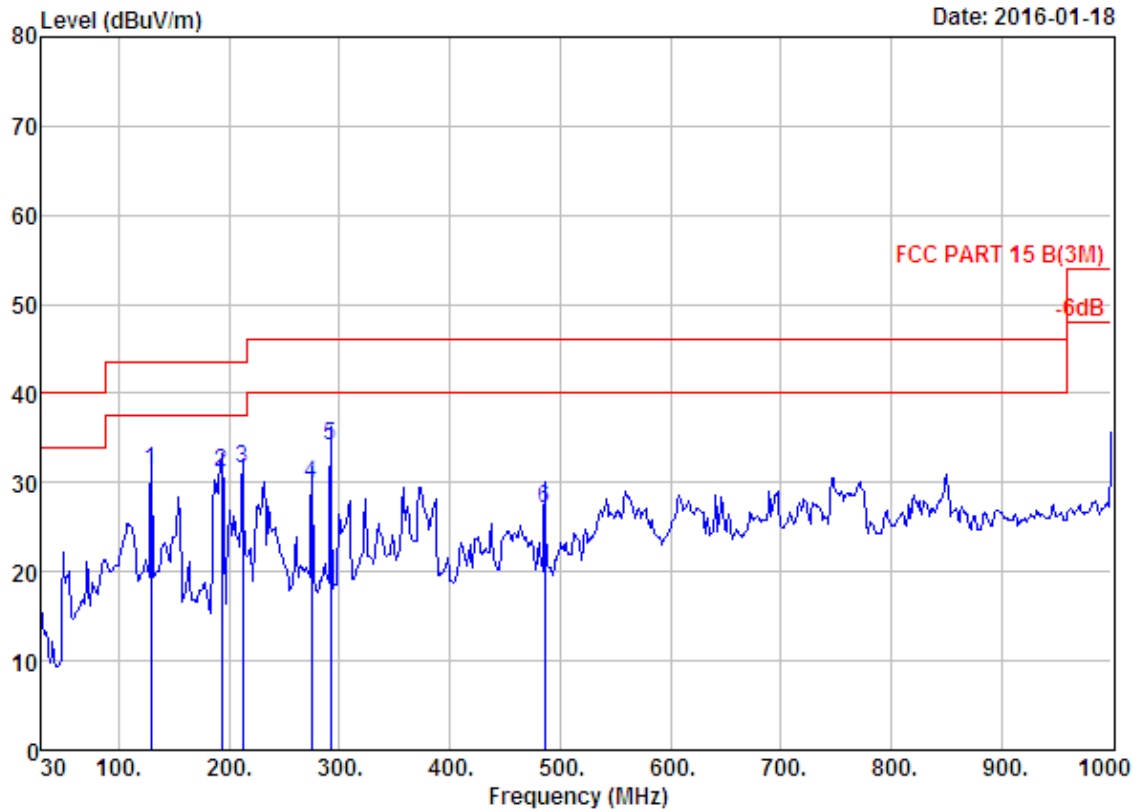

Site no. : 966 1# chamber Data no. : 116
 Dis. / Ant. : 3m 27137 Ant. pol. : HORIZONTAL
 Limit : FCC PART 15 B(3M)
 Env. / Ins. : Temp:23.6';Humi:56%;Press:101.52kPa
 Engineer : Dick
 EUT : LED Backlight TV
 Power : AC 120V/60Hz
 M/N : HU40M2160F
 Test Mode : VGA Mode(1024*768+Running "H" Pattern)

	Freq. (MHz)	Ant. Factor (dB/m)	Cable Loss (dB)	Reading (dBuV)	Emission Level (dBuV/m)	Limits (dBuV/m)	Margin (dB)	Remark
1	128.94	11.33	1.47	18.48	31.28	43.50	12.22	QP
2	192.96	7.85	1.77	21.61	31.23	43.50	12.27	QP
3	212.36	8.56	1.91	21.16	31.63	43.50	11.87	QP
4	274.44	12.39	2.22	15.20	29.81	46.00	16.19	QP
5	291.90	12.83	2.33	19.01	34.17	46.00	11.83	QP
6	485.90	17.67	3.10	6.37	27.14	46.00	18.86	QP

Above 1GHz

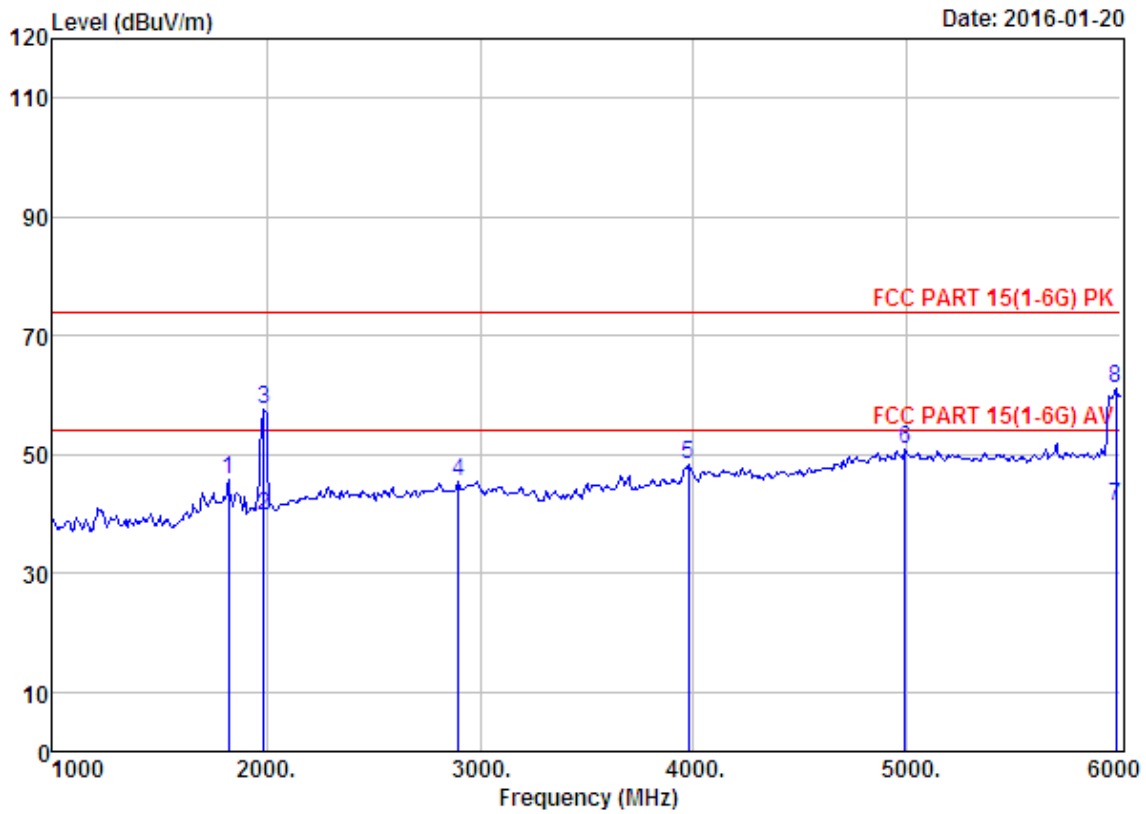

Site no. : 1# 966 chamber Data no. : 119
 Dis. / Ant. : 3m ANT 1-18G Ant. pol. : VERTICAL
 Limit : FCC PART 15(1-6G) PK
 Env. / Ins. : Temp:23.6';Humi:56%;Press:101.52kPa
 Engineer : Bible
 EUT : LED Backlight TV
 Power : AC 120V/60Hz
 M/N : HU40M2160F
 Test Mode : HDMI Mode(1024*768+Running "H" Pattern)

	Freq. (MHz)	Ant. Factor (dB/m)	Cable Loss (dB)	Amp Factor (dB)	Reading (dBuV)	Emission Level (dBuV/m)	Limits (dBuV/m)	Margin (dB)	Remark
1	1825.00	25.09	5.57	35.27	50.50	45.89	74.00	28.11	Peak
2	1990.00	25.79	6.13	35.08	42.82	39.66	54.00	14.34	Average
3	1990.00	25.79	6.13	35.08	60.65	57.49	74.00	16.51	Peak
4	2900.00	28.01	8.59	37.25	46.22	45.57	74.00	28.43	Peak
5	3975.00	29.60	10.81	36.42	44.23	48.22	74.00	25.78	Peak
6	4990.00	31.54	12.59	36.06	42.77	50.84	74.00	23.16	Peak
7	5975.00	32.74	12.12	35.59	32.06	41.33	54.00	12.67	Average
8	5975.00	32.74	12.12	35.59	51.78	61.05	74.00	12.95	Peak

Remarks: 1. Emission Level= Antenna Factor + Cable Loss - Amp Factor + Reading.
 2. The emission levels that are 20dB below the official limit are not reported.

5. PHOTOGRAPHS OF TEST SET-UP

5.1. Set-up for conducted emission at the mains terminals test



5.2. Set-up for radiated emission test (30-1000MHz)

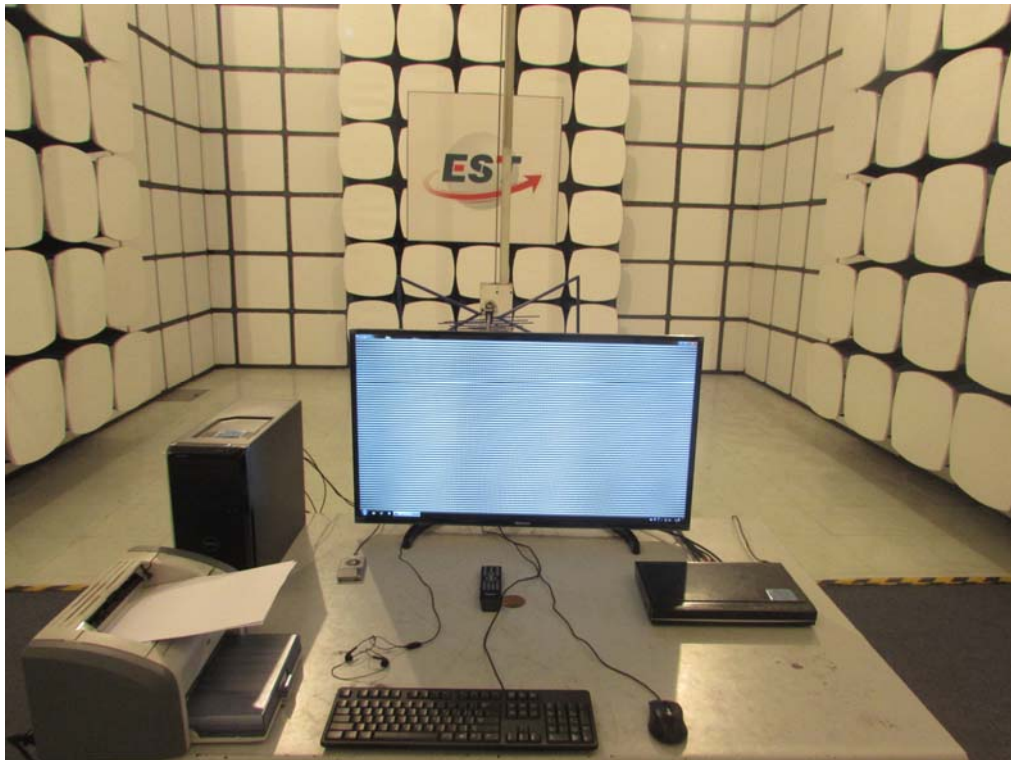

5.3. Set-up for radiated emission test (Above 1GHz)

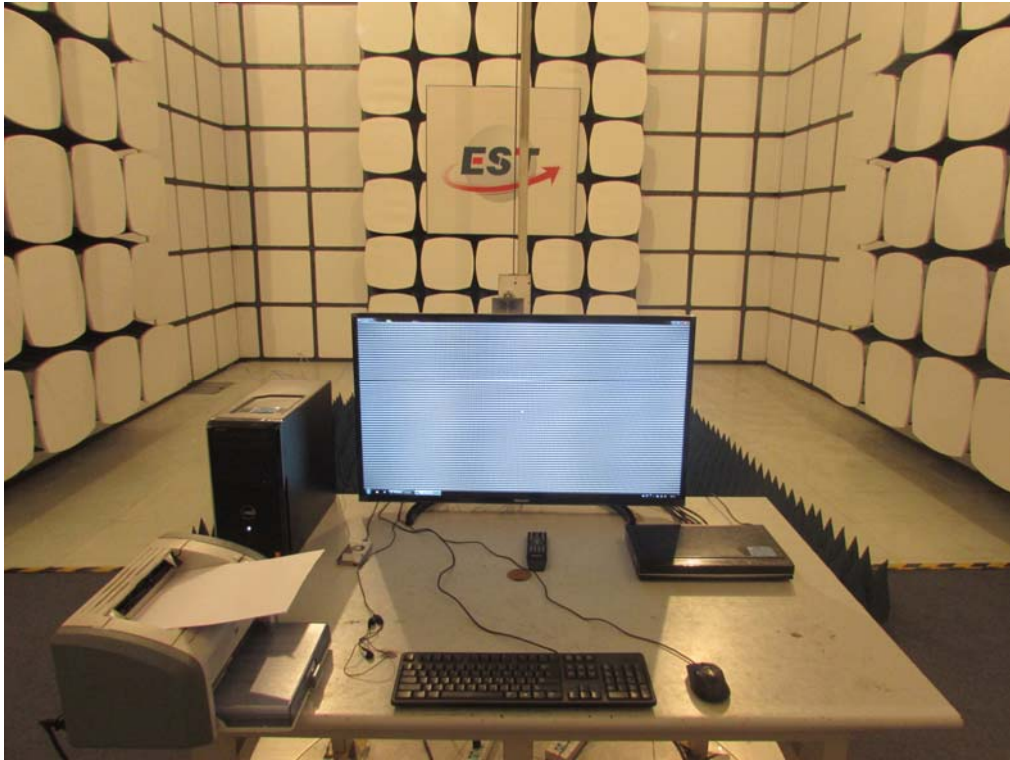

6. PHOTOGRAPHS OF THE EUT

External Photos
M/N: HU40M2160F



External Photos
M/N: HU40M2160F



External Photos
M/N: HU40M2160F



External Photos
M/N: HU40M2160F



External Photos
M/N: HU40M2160F



Internal Photos
M/N: HU40M2160F

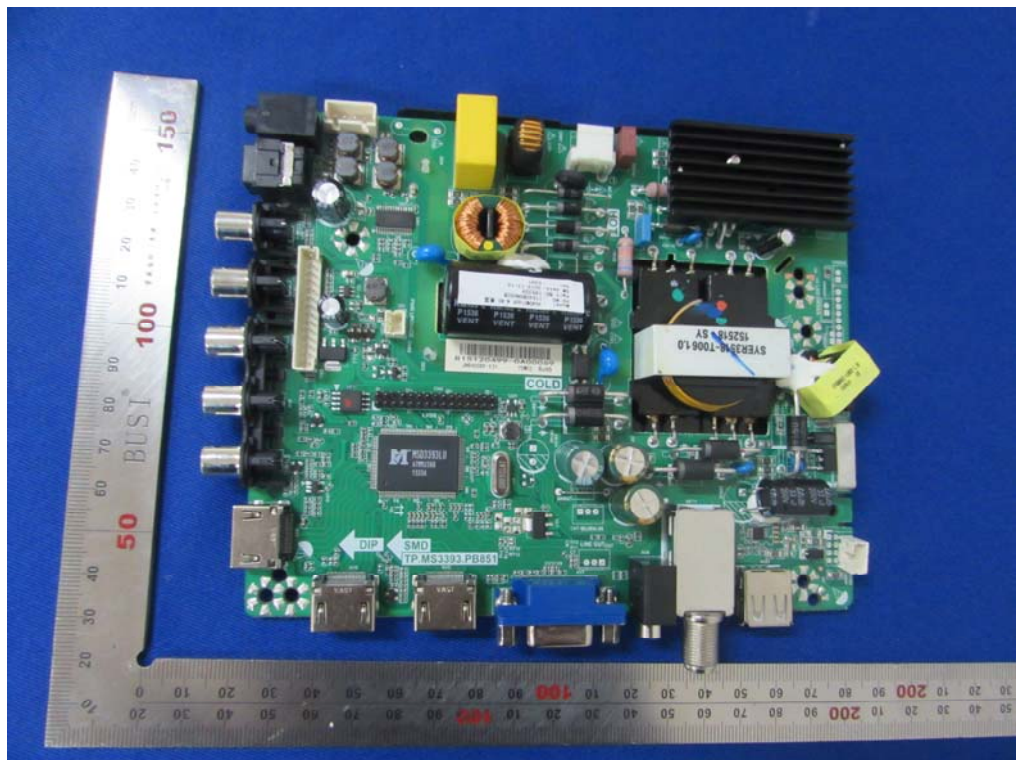

Internal Photos
M/N: HU40M2160F

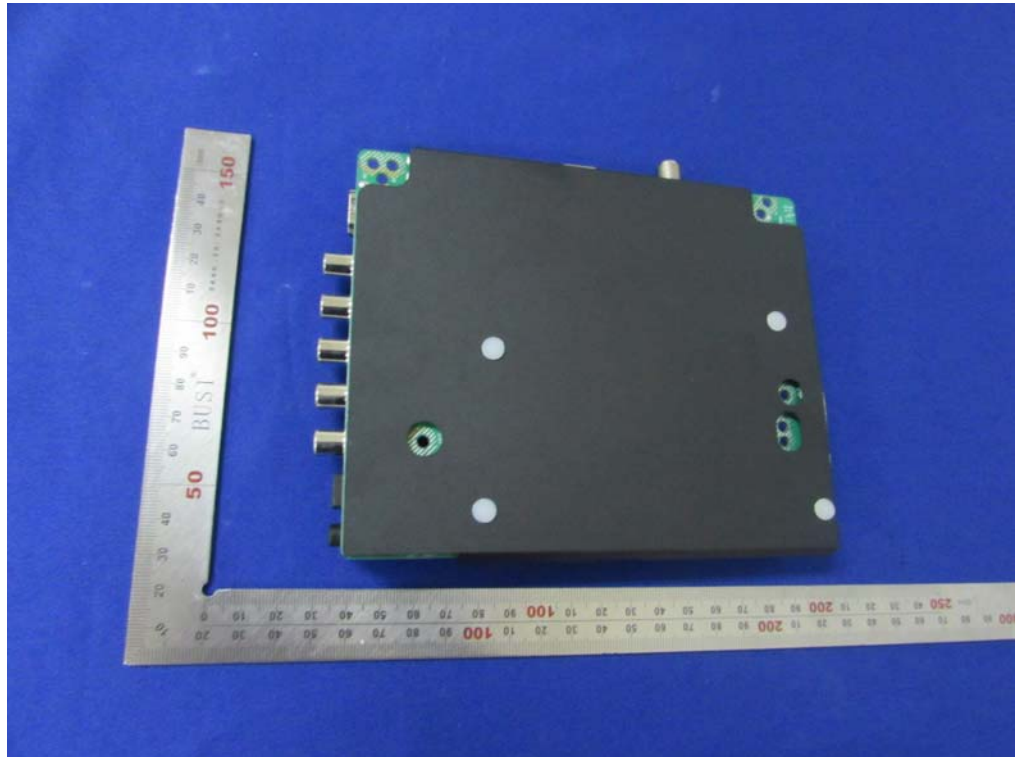

Internal Photos
M/N: HU40M2160F

