

Application for FCC Certificate
On Behalf of
Hisense Electric Co., Ltd.

LED LCD TV

Model No.	Brand
LC-40N5000U, LC-40N5000C	Sharp

FCC ID : W9HLCDD0053

Prepared For : Hisense Electric Co., Ltd.
No.218 Qianwangang Road, Economy & Technology
Development Zone, Qingdao, China

Prepared By : Audix Technology (Shanghai) Co., Ltd.
3F and 4F, 34Bldg 680 Guiping Rd,
Caohejing Hi-Tech Park,
Shanghai 200233, China

Tel: +86-21-64955500

Fax: +86-21-64955491

Report No. : ACI-F16029
Date of Test : Dec 24, 2015 - Jan 13, 2016
Date of Report : Jan 22, 2016

TABLE OF CONTENTS

	Page
1 SUMMARY OF STANDARDS AND RESULTS.....	4
1.1 Description of Standards and Results.....	4
2 GENERAL INFORMATION.....	5
2.1 Description of Equipment Under Test.....	5
2.2 Peripherals.....	6
2.3 Description of Test Facility.....	6
2.4 Measurement Uncertainty.....	8
3 CONDUCTED EMISSION TEST.....	9
3.1 Test Equipment.....	9
3.2 Block Diagram of Test Setup.....	9
3.3 Conducted Emission Limit [FCC Part 15 Subpart B 15.107(a)].....	10
3.4 Test Configuration.....	10
3.5 Operating Condition of EUT.....	11
3.6 Test Procedures.....	11
3.7 Test Results.....	12
4 RADIATED EMISSION TEST.....	19
4.1 Test Equipment.....	19
4.2 Block Diagram of Test Setup.....	19
4.3 Radiated Emission Limit [FCC Part 15 Subpart B 15.109(a)].....	21
4.4 Test Configuration.....	21
4.5 Operating Condition of EUT.....	22
4.6 Test Procedures.....	22
4.7 Test Results.....	23
5 DEVIATION TO TEST SPECIFICATIONS.....	32

TEST REPORT FOR FCC CERTIFICATE

Applicant : Hisense Electric Co., Ltd.
 Manufacturer : Hisense Electric Co., Ltd.
 Factory #1 : Hisense Electric Co., Ltd.
 Factory #2 : Tatung Mexico S.A. de C.V.
 Factory #3 : HISENSE ELECTRONICA MEXICO, S.A. DE C.V.
 EUT Description : LED LCD TV

Model No.	Brand	Power Supply
LC-40N5000U, LC-40N5000C	Sharp	120V/60Hz

Test Procedure Used:

*FCC RULES AND REGULATIONS PART 15 SUBPART B CLASS B OCTOBER 2014
AND ANSI C63.4-2003*

The device described above is tested by Audix Technology (Shanghai) Co., Ltd. to determine the maximum emission levels emanating from the device. The maximum emission levels are compared to the FCC Part 15 Subpart B (Class B) limits both radiated and conducted emissions.

The test results are contained in this test report and Audix Technology (Shanghai) Co., Ltd. is assumed full responsibility for the accuracy and completeness of these measurements. This report shows that the EUT (M/N: Refer to Sec2.1) which was tested in 3m anechoic chamber Dec 24, 2015 - Jan 13, 2016 is technically compliance with the FCC official limits also.

This report applies to above tested sample only. This report shall not be reproduced in part without written approval of Audix Technology (Shanghai) Co., Ltd.

This report contains data that are not covered by the NVLAP accreditation.

This report must not be used by the client to claim product certification, approval, or endorsement by NVLAP, NIST, or any agency of the federal government.

The test results for EUT's TV functions are contained in No.F16028, a Verification report.

Date of Test : Dec 24, 2015 - Jan 13, 2016 Date of Report : Jan 22, 2016

Producer :

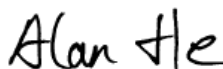

ALAN HE / Assistant

Review :

SAMMY CHEN / Manager

 For and on behalf of
Audix Technology (Shanghai) Co., Ltd.

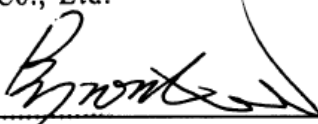
Signatory :

Authorized Signature EMC BYRON KWO / Assistant General Manager

1 SUMMARY OF STANDARDS AND RESULTS

1.1 Description of Standards and Results

The EUT have been tested according to the applicable standards as referenced below:

Description of Test Item	Standard	Limits	Results
EMISSION			
Conducted Disturbance at the Mains Terminal	FCC RULES AND REGULATIONS PART 15 SUBPART B OCTOBER 2014 AND ANSI C63.4-2003	15.107(a) Class B	Pass
Radiated Disturbance	FCC RULES AND REGULATIONS PART 15 SUBPART B OCTOBER 2014 AND ANSI C63.4-2003	15.109(a) Class B	Pass

2 GENERAL INFORMATION

2.1 Description of Equipment Under Test

Description	:	LED LCD TV
Type of EUT	:	<input checked="" type="checkbox"/> Production <input type="checkbox"/> Pre-product <input type="checkbox"/> Pro-type
Model No	:	LC-40N5000U, LC-40N5000C
Note	:	The above models are all the same except for model number.LC-40N5000U model is tested and recorded in the report.
Brand	:	Sharp
Applicant	:	Hisense Electric Co., Ltd. No.218 Qianwangang Road, Economy & Technology Development Zone, Qingdao, China
Manufacturer	:	same as Applicant
Factory #1	:	same as Applicant
Factory #2	:	Tatung Mexico S.A. de C.V. Miguel Catalán 420, Parque Industrial Rio Bravo, Cd. Juarez, Chih., CP 32557
Factory #3	:	HISENSE ELECTRONICA MEXICO, S.A.DE C.V. Blvd. Sharp #3510 Parque Industrial Rosarito, C.P. 22710 Playas de Rosarito, B.C.
LCD Panel	:	Manufacturer : Hisense M/N : HD400DF-E34
Tuner	:	Manufacturer : XuGuang Tech. Co., Ltd. M/N : HFT-96S3/W11FJ4H\ROH
Max Resolution	:	1920*1080@60Hz
HDMI Cable*3 (Lab provide)	:	Shielded, Detachable, 1.50m
Power Cord	:	Unshielded, Detachable, 1.80m, 2C
LAN Cable	:	Shielded, Detachable, 1.50m
USB Cable*2 (Lab provide)	:	Shielded, Detachable, 1.00m, without core.

Remark:

The EUT is a LED LCD TV which input/output ports as follows:

Side Port:

- (1) One HDMI 1 Port : Connected with DVD PLAYER #1
- (2) One HDMI 2 Port : Connected with PC
- (3) One Audio out Port : Connected with Earphone
- (4) One USB 1 Port : Connected with Hard-Disk #1
- (5) One USB 2 Port : Connected with Hard-Disk #2
- (6) One DEBUG Port : This port does not open to user
- (7) One ANT/CABLE IN Port : Connected with ATSC SG / TV SG

Back Port:

- (8) One LAN Port : Connected with PC
- (9) One HDMI3 Port : Connected with DVD PLAYER #2
- (10) One Digital Audio Out Port : Connected with DVD PLAYER #2
- (11) One COMPONENT IN/AV IN Port : Connected with DVD PLAYER #2

2.2 Peripherals

2.2.1 PC

Manufacturer : HP
 Model Number : dx7400MT
 Serial Number : CNG8130K89
 Power Cord : Unshielded, Detachable, 1.8m
 Certificate : FCC DoC; CE/EMC; VCCI; C-Tick;

2.2.2 Keyboard

Manufacturer : Microsoft
 Model Number : RT2300
 Serial Number : 7668200662248
 Data Cable : Shielded, undetachable, 1.8m
 Certificate : CE/EMC, FCC DoC, VCCI, MIC, C-Tick, BSMI

2.2.3 Mouse

Manufacturer : Microsoft
Model Number : RT2300
Serial Number : 6965712071551
Data Cable : Shielded, Undetachable, 1.8m.
Certificate : CE/EMC, FCC DoC, VCCI, MIC,
C-Tick, BSMI

2.2.4 Modem

Manufacturer : TP-LINK
Model Number : TM-EC5658V
Serial Number : 07123301053
Data Cable : Shielded, Detachable, 1.8m
Certificate : CCC

2.2.5 Earphone

Manufacturer : audio-technica
Model Number : ATH-CKL200

2.2.6 TV Signal Generator

Manufacturer : FLUKE
Model Number : 54200M01
Serial Number : 814008

2.2.7 ATSC Signal Generator

Manufacturer : SENCORE
Model Number : ATSC997
Serial Number : 6790071

2.2.8 DVD PLAYER #1

Manufacturer : PHILIPS
Model Number : DVP3986K/93
Serial Number : KX1A0902120108
Certificate : CCC

2.2.9 DVD PLAYER #2

Manufacturer : PHILIPS
Model Number : DVP3986K/93
Serial Number : KX1A0902120082
Certificate : CCC

2.2.10 Hard Disk #1

Manufacturer : Tetasys
Model Number : F12
Serial Number : A010022-4860010X
Data Cable : Shielded, Undetachable, 1.8m.
Certificate : CE, FCC DoC

2.2.11 Hard Disk #2

Manufacturer : Tetasys
Model Number : F12
Serial Number : A010022-4A60007
Data Cable : Shielded, Undetachable, 1.8m.
Certificate : CE, FCC DoC

2.3 Description of Test Facility

Site Description (No.3 3m Chamber) : Sept. 17, 1998 file on
Jan.15, 2015 Renewed
Federal Communications Commission
FCC Engineering Laboratory
7435 Oakland Mills Road
Columbia, MD 21046, USA

Name of Firm : Audix Technology (Shanghai) Co., Ltd.

Site Location : 3F 34Bldg 680 Guiping Rd,
Caohejing Hi-Tech Park,
Shanghai 200233, China

NVLAP Lab Code : 200371-0

2.4 Measurement Uncertainty

Conducted Emission Expanded Uncertainty : U = 3.4dB
Radiated Emission Expanded Uncertainty (30-200MHz):
U = 4.6dB (Horizontal)
U = 4.3dB (Vertical)

Radiated Emission Expanded Uncertainty (200M-1GHz):
U = 4.5dB (Horizontal)
U = 5.4dB (Vertical)

Radiated Emission Expanded Uncertainty (1GHz-6GHz):
U = 5.1dB

3 CONDUCTED EMISSION TEST

3.1 Test Equipment

The following test equipments are used during the conducted emission test in a shielded room:

Item	Type	Manufacturer	Model No.	Serial No.	Last Cal.	Next Cal.
1.	Test Receiver	R&S	ESCI	101302	Jul 03, 2015	Jul 02, 2016
2.	Artificial Mains Network (AMN)	R&S	ENV4200	100125	Jun 27, 2015	Jun 26, 2016
3.	Line Impedance Stabilization Network (LISN)	Kyoritsu	KNW-407	8-1280-5	Mar 20, 2015	Mar 19, 2016
4.	50Ω Terminator	Anritsu	BNC	001	Mar 20, 2015	Mar 19, 2016
5.	Software	Audix	E3	6.111206	--	--

3.2 Block Diagram of Test Setup

3.2.1 EUT & Peripherals

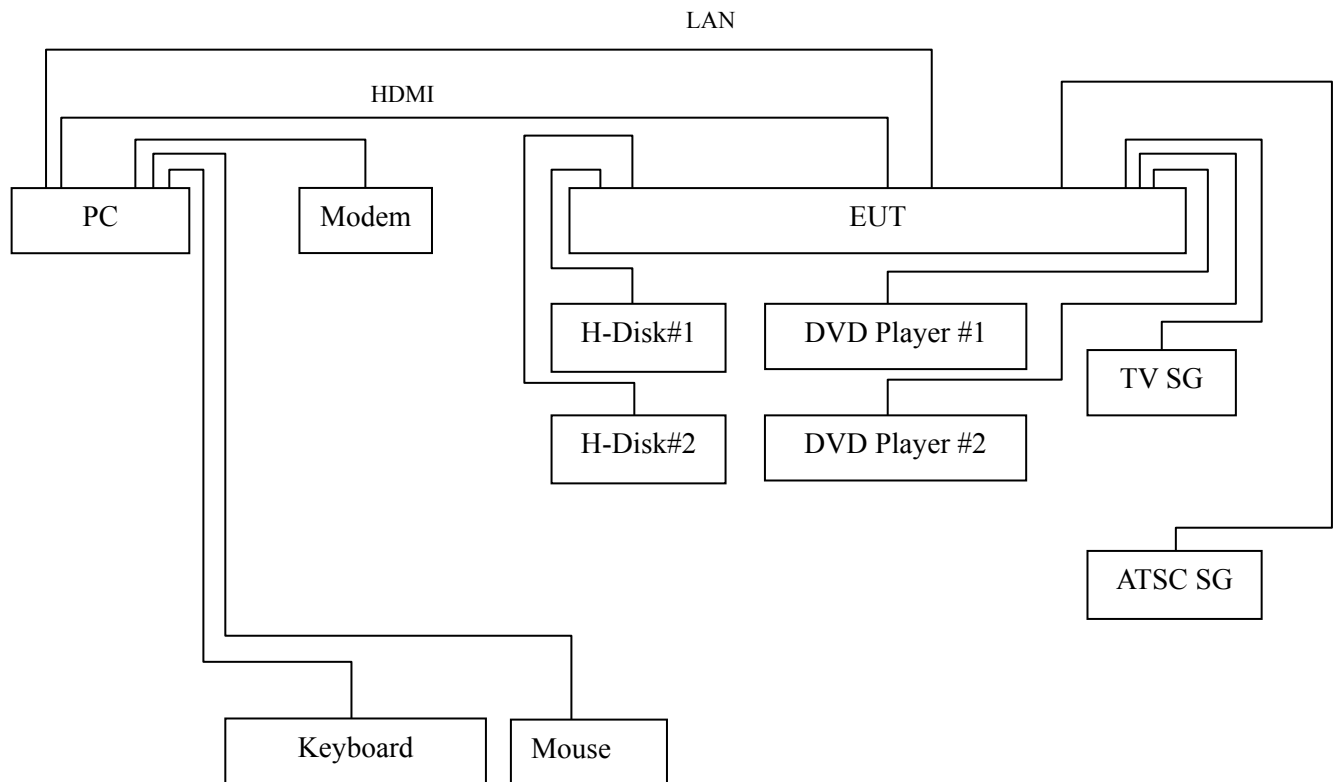

3.2.2 Conducted Disturbance Test Setup

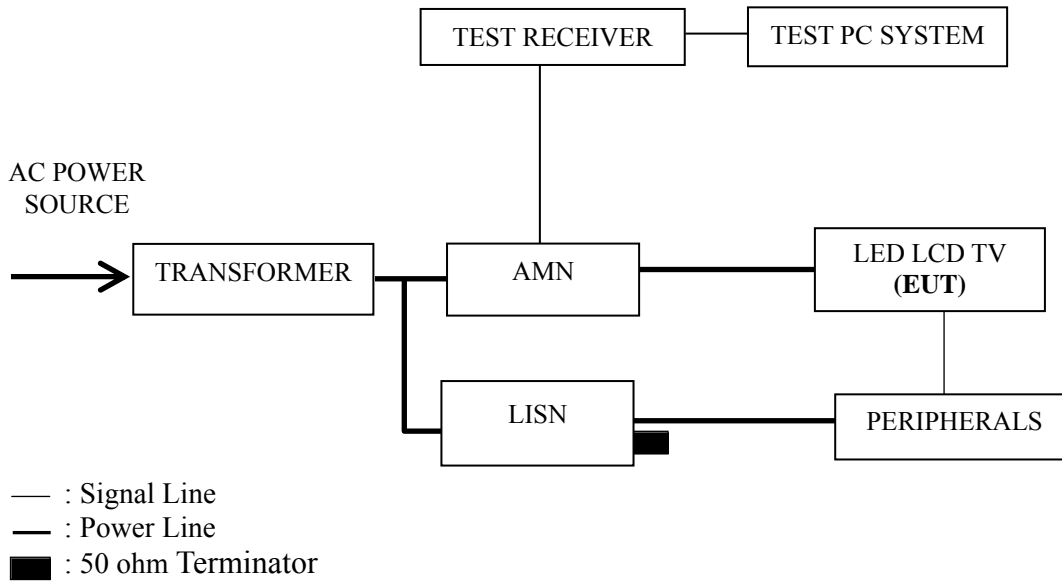

3.3 Conducted Emission Limit [FCC Part 15 Subpart B 15.107(a)]

Frequency Range (MHz)	Limits dB (μ V)	
	Quasi-peak	Average
0.15 ~ 0.5	66~56	56~46
0.5 ~ 5	56	46
5 ~ 30	60	50

NOTE 1 – The lower limit shall apply at the transition frequencies.
 NOTE 2 – The limit decreases linearly with the logarithm of the frequency in the range 0.15 MHz~0.50 MHz

3.4 Test Configuration

The EUT (listed in Sec.2.1) and the peripherals (listed in Sec 2.2) were installed as shown on Sec.3.2 to meet FCC requirement and operating in a manner that tends to maximize its emission level in a normal application.

3.5 Operating Condition of EUT

- 3.5.1 Setup the EUT and peripherals as shown in Sec. 3.2.
- 3.5.2 Turn on the power of all equipments and the EUT.
- 3.5.3 Set the contrast & brightness of EUT to maximum.
- 3.5.4 PC system ran the self-test program “EMC Test” by windows XP and sent “H” characters to EUT through graphic card, the EUT’s screen displayed and filled with “H” pattern by its resolution (Via HDMI Input).
- 3.5.5 PC system sent the 1kHz audio signal to EUT through audio port, the EUT speak out 1kHz audio signal.
- 3.5.6 In USB Play mode, set the EUT play digital media from Hard Disk.
- 3.5.7 In LAN Play mode, set the EUT play digital media through LAN port.
- 3.5.8 The other peripherals devices were driven and operated during the test.
- 3.5.9 The test modes are as follows:

Test Mode
HDMI 1920*1080@60Hz & 1kHz playing
HDMI 1280*1024@60Hz & 1kHz playing
HDMI 640*480@60Hz & 1kHz playing
HDMI1080P
USB Play
LAN Play

3.6 Test Procedures

The EUT and peripherals were connected to the power mains through an Artificial Mains Network (AMN). This provided a 50 ohm coupling impedance for the measuring equipment.

Both sides of AC line (Line & Neutral) were checked for maximum conducted interference. In order to find the maximum emission, the relative positions of equipment and all of the interface cables were changed or manipulated according to ANSI C63.4:2003 during conducted emission test.

The bandwidth of R&S Test Receiver ESCI was set at 9 kHz.

The frequency range from 150 kHz to 30 MHz was checked.

The test modes were done on conducted disturbance test and all the test results are listed in Sec. 3.7.

3.7 Test Results

< **PASS** >

The frequency and amplitude of the highest conducted emission relative to the limit is reported. All emissions not reported below are too low against the prescribed limits.

Test Mode	Data Page
HDMI 1920*1080@60Hz & 1kHz playing	P13
HDMI 1280*1024@60Hz & 1kHz playing	P14
HDMI 640*480@60Hz & 1kHz playing	P15
HDMI1080P	P16
USB Play	P17
LAN Play	P18

NOTE 1 – Factor = Cable Loss + AMN Factor.

NOTE 2 – Emission Level = Meter Reading + Factor.

NOTE 3 – “QP” means “Quasi-Peak” values, “AV” means “Average” values.

NOTE 4 – The worst case is for USB Play test mode. The worst emission is detected at 0.608MHz (Average Value) with corrected signal level of 36.28 dB (μ V) (limit is 46.00 dB (μ V)), when the Line of the EUT is connected to AMN.

EUT : LED LCD TV Temperature : 22°C

Model No. : LC-40N5000U Humidity : 48%RH

Test Mode : HDMI 1920*1080@60Hz Date of Test : Dec 24, 2015
& 1kHz Playing

Test Line	Frequency (MHz)	Meter Reading dB(μ V)	Factor (dB)	Emission Level dB(μ V)	Limits dB(μ V)	Margin (dB)	Remark
Line	0.151	30.59	10.59	41.18	65.95	24.77	QP
	0.274	34.40	10.47	44.87	61.00	16.13	
	0.608	34.20	10.38	44.58	56.00	11.42	
	0.915	32.50	10.38	42.88	56.00	13.12	
	1.505	29.10	10.40	39.50	56.00	16.50	
	6.229	27.20	10.47	37.67	60.00	22.33	
	AV	0.151	9.49	10.59	20.08	55.95	35.87
		0.274	23.10	10.47	33.57	51.00	17.43
		0.608	25.70	10.38	36.08	46.00	9.92
		0.915	22.60	10.38	32.98	46.00	13.02
		1.505	12.60	10.40	23.00	46.00	23.00
		6.229	13.00	10.47	23.47	50.00	26.53
Neutral	0.192	27.70	10.51	38.21	63.95	25.74	QP
	0.279	29.60	10.45	40.05	60.85	20.80	
	0.609	32.60	10.36	42.96	56.00	13.04	
	0.915	31.40	10.37	41.77	56.00	14.23	
	1.509	28.80	10.39	39.19	56.00	16.81	
	5.957	25.20	10.49	35.69	60.00	24.31	
	AV	0.192	16.80	10.51	27.31	53.95	26.64
		0.279	16.80	10.45	27.25	50.85	23.60
		0.609	24.30	10.36	34.66	46.00	11.34
		0.915	21.30	10.37	31.67	46.00	14.33
		1.509	13.10	10.39	23.49	46.00	22.51
		5.957	11.40	10.49	21.89	50.00	28.11

TEST ENGINEER: WENCY YANG

EUT : LED LCD TV Temperature : 22°C

Model No. : LC-40N5000U Humidity : 48%RH

Test Mode : HDMI 1280*1024@60Hz & 1kHz Playing Date of Test : Dec 24, 2015

Test Line	Frequency (MHz)	Meter Reading dB(μ V)	Factor (dB)	Emission Level dB(μ V)	Limits dB(μ V)	Margin (dB)	Remark
Line	0.275	34.20	10.47	44.67	60.95	16.28	QP
	0.611	33.80	10.38	44.18	56.00	11.82	
	0.913	32.20	10.38	42.58	56.00	13.42	
	1.641	27.40	10.40	37.80	56.00	18.20	
	2.434	26.51	10.42	36.93	56.00	19.07	
	5.679	25.30	10.47	35.77	60.00	24.23	
	AV	0.275	22.80	10.47	33.27	50.95	17.68
		0.611	25.00	10.38	35.38	46.00	10.62
		0.913	22.60	10.38	32.98	46.00	13.02
		1.641	12.30	10.40	22.70	46.00	23.30
		2.434	15.61	10.42	26.03	46.00	19.97
		5.679	11.60	10.47	22.07	50.00	27.93
Neutral	0.192	27.80	10.51	38.31	63.97	25.66	QP
	0.274	29.90	10.45	40.35	61.00	20.65	
	0.595	31.40	10.36	41.76	56.00	14.24	
	1.494	28.40	10.39	38.79	56.00	17.21	
	2.700	25.20	10.43	35.63	56.00	20.37	
	6.214	26.60	10.50	37.10	60.00	22.90	
	AV	0.192	16.90	10.51	27.41	53.97	26.56
		0.274	19.40	10.45	29.85	51.00	21.15
		0.595	17.00	10.36	27.36	46.00	18.64
		1.494	13.70	10.39	24.09	46.00	21.91
		2.700	12.50	10.43	22.93	46.00	23.07
		6.214	12.80	10.50	23.30	50.00	26.70

TEST ENGINEER: WENCY YANG

EUT : LED LCD TV Temperature : 22°C

Model No. : LC-40N5000U Humidity : 48%RH

Test Mode : HDMI 640*480@60Hz & 1kHz Playing Date of Test : Dec 24, 2015

Test Line	Frequency (MHz)	Meter Reading dB(μ V)	Factor (dB)	Emission Level dB(μ V)	Limits dB(μ V)	Margin (dB)	Remark
Line	0.276	34.20	10.47	44.67	60.94	16.27	QP
	0.609	34.20	10.38	44.58	56.00	11.42	
	1.159	28.81	10.38	39.19	56.00	16.81	
	1.822	29.30	10.41	39.71	56.00	16.29	
	3.646	22.51	10.45	32.96	56.00	23.04	
	6.210	27.20	10.47	37.67	60.00	22.33	AV
	0.276	22.70	10.47	33.17	50.94	17.77	
	0.609	25.90	10.38	36.28	46.00	9.72	
	1.159	9.71	10.38	20.09	46.00	25.91	
	1.822	12.80	10.41	23.21	46.00	22.79	
Neutral	3.646	10.91	10.45	21.36	46.00	24.64	QP
	6.210	12.50	10.47	22.97	50.00	27.03	
	0.189	28.20	10.52	38.72	64.10	25.38	
	0.273	30.11	10.45	40.56	61.04	20.48	
	0.607	32.90	10.36	43.26	56.00	12.74	
	AV	1.150	28.31	10.37	38.68	56.00	17.32
		1.498	28.20	10.39	38.59	56.00	17.41
		6.217	25.80	10.50	36.30	60.00	23.70
		0.189	17.10	10.52	27.62	54.10	26.48
		0.273	19.61	10.45	30.06	51.04	20.98
		0.607	24.10	10.36	34.46	46.00	11.54
		1.150	8.71	10.37	19.08	46.00	26.92
		1.498	15.30	10.39	25.69	46.00	20.31
		6.217	12.90	10.50	23.40	50.00	26.60

TEST ENGINEER: WENCY YANG

EUT : LED LCD TV Temperature : 22°C

Model No. : LC-40N5000U Humidity : 48%RH

Test Mode : HDMI1080P Date of Test : Dec 24, 2015

Test Line	Frequency (MHz)	Meter Reading dB(μ V)	Factor (dB)	Emission Level dB(μ V)	Limits dB(μ V)	Margin (dB)	Remark
Line	0.275	34.30	10.47	44.77	60.95	16.18	QP
	0.609	33.90	10.38	44.28	56.00	11.72	
	0.915	32.50	10.38	42.88	56.00	13.12	
	1.507	29.30	10.40	39.70	56.00	16.30	
	3.787	25.41	10.45	35.86	56.00	20.14	
	5.680	25.20	10.47	35.67	60.00	24.33	
	0.275	23.10	10.47	33.57	50.95	17.38	AV
	0.609	25.60	10.38	35.98	46.00	10.02	
	0.915	22.40	10.38	32.78	46.00	13.22	
	1.507	13.40	10.40	23.80	46.00	22.20	
	3.787	10.81	10.45	21.26	46.00	24.74	
	5.680	11.70	10.47	22.17	50.00	27.83	
Neutral	0.152	29.79	10.59	40.38	65.91	25.53	QP
	0.276	29.90	10.45	40.35	60.94	20.59	
	0.606	32.70	10.36	43.06	56.00	12.94	
	1.144	28.51	10.37	38.88	56.00	17.12	
	1.824	28.49	10.41	38.90	56.00	17.10	
	6.215	26.30	10.50	36.80	60.00	23.20	
	0.152	8.49	10.59	19.08	55.91	36.83	AV
	0.276	19.10	10.45	29.55	50.94	21.39	
	0.606	23.50	10.36	33.86	46.00	12.14	
	1.144	8.61	10.37	18.98	46.00	27.02	
	1.824	12.79	10.41	23.20	46.00	22.80	
	6.215	12.70	10.50	23.20	50.00	26.80	

TEST ENGINEER: WENCY YANG

EUT : LED LCD TV Temperature : 22°C

Model No. : LC-40N5000U Humidity : 48%RH

Test Mode : USB Play Date of Test : Dec 24, 2015

Test Line	Frequency (MHz)	Meter Reading dB(μ V)	Factor (dB)	Emission Level dB(μ V)	Limits dB(μ V)	Margin (dB)	Remark
Line	0.275	34.30	10.47	44.77	60.97	16.20	QP
	0.608	34.30	10.38	44.68	56.00	11.32	
	0.912	32.20	10.38	42.58	56.00	13.42	
	1.493	28.90	10.40	39.30	56.00	16.70	
	3.517	25.10	10.45	35.55	56.00	20.45	
	5.951	26.20	10.47	36.67	60.00	23.33	
	0.275	23.00	10.47	33.47	50.97	17.50	AV
	0.608	25.90	10.38	36.28	46.00	9.72	
	0.912	22.50	10.38	32.88	46.00	13.12	
	1.493	12.80	10.40	23.20	46.00	22.80	
	3.517	12.70	10.45	23.15	46.00	22.85	
	5.951	12.00	10.47	22.47	50.00	27.53	
Neutral	0.191	28.49	10.52	39.01	64.01	25.00	QP
	0.274	30.11	10.45	40.56	61.01	20.45	
	0.601	31.90	10.36	42.26	56.00	13.74	
	1.142	28.31	10.37	38.68	56.00	17.32	
	1.623	28.61	10.39	39.00	56.00	17.00	
	6.214	26.50	10.50	37.00	60.00	23.00	
	0.191	17.39	10.52	27.91	54.01	26.10	AV
	0.274	19.51	10.45	29.96	51.01	21.05	
	0.601	18.80	10.36	29.16	46.00	16.84	
	1.142	8.81	10.37	19.18	46.00	26.82	
	1.623	13.91	10.39	24.30	46.00	21.70	
	6.214	12.70	10.50	23.20	50.00	26.80	

TEST ENGINEER: WENCY YANG

EUT : LED LCD TV Temperature : 22°C
 Model No. : LC-40N5000U Humidity : 48%RH
 Test Mode : LAN Play Date of Test : Dec 24, 2015

Test Line	Frequency (MHz)	Meter Reading dB(μV)	Factor (dB)	Emission Level dB(μV)	Limits dB(μV)	Margin (dB)	Remark
Line	0.275	34.20	10.47	44.67	60.98	16.31	QP
	0.609	34.10	10.38	44.48	56.00	11.52	
	0.914	32.50	10.38	42.88	56.00	13.12	
	1.505	29.30	10.40	39.70	56.00	16.30	
	3.813	23.60	10.46	34.06	56.00	21.94	
	5.937	26.60	10.47	37.07	60.00	22.93	
	0.275	23.10	10.47	33.57	50.98	17.41	AV
	0.609	25.70	10.38	36.08	46.00	9.92	
	0.914	22.60	10.38	32.98	46.00	13.02	
	1.505	13.60	10.40	24.00	46.00	22.00	
	3.813	10.30	10.46	20.76	46.00	25.24	
	5.937	11.70	10.47	22.17	50.00	27.83	
Neutral	0.189	28.60	10.52	39.12	64.06	24.94	QP
	0.272	30.21	10.45	40.66	61.04	20.38	
	0.593	31.10	10.36	41.46	56.00	14.54	
	1.137	28.51	10.37	38.88	56.00	17.12	
	1.501	28.50	10.39	38.89	56.00	17.11	
	5.937	25.20	10.49	35.69	60.00	24.31	
	0.189	17.20	10.52	27.72	54.06	26.34	AV
	0.272	19.51	10.45	29.96	51.04	21.08	
	0.593	17.00	10.36	27.36	46.00	18.64	
	1.137	8.91	10.37	19.28	46.00	26.72	
	1.501	12.90	10.39	23.29	46.00	22.71	
	5.937	11.10	10.49	21.59	50.00	28.41	

TEST ENGINEER: WENCY YANG

4 RADIATED EMISSION TEST

4.1 Test Equipment

The following test equipments are used during the radiated emission test in a semi-anechoic chamber:

Item	Type	Manufacturer	Model No.	Serial No.	Last Cal.	Next Cal.
1.	Test Receiver	R&S	ESCI	101303	May 07, 2015	May 06, 2016
2.	Preamplifier	Agilent	8447D	2944A06664	Apr 27, 2015	Apr 26, 2016
3.	Preamplifier	HP	8449B	3008A00864	Mar 20, 2015	Sep 19, 2016
4.	Bi-log Antenna	TESEQ	CBL6112D	23193	May 15, 2015	May 14, 2016
5.	Horn Antenna	EMCO	3115	9607-4878	Jun 03, 2015	Jun 02, 2016
6.	Spectrum	Agilent	N9010A	MY52221182	Jun 12, 2015	Jun 11, 2016
7.	Spectrum	HP	8591EM	3628A00908	May 07, 2015	May 06, 2016
8.	50Ω Coaxial Switch	Anritsu	MP59B	6200426390	Sep 18, 2015	Mar 17, 2016
9.	Software	Audix	E3	6.2007-9-10	--	--

4.2 Block Diagram of Test Setup

4.2.1 EUT & Peripherals

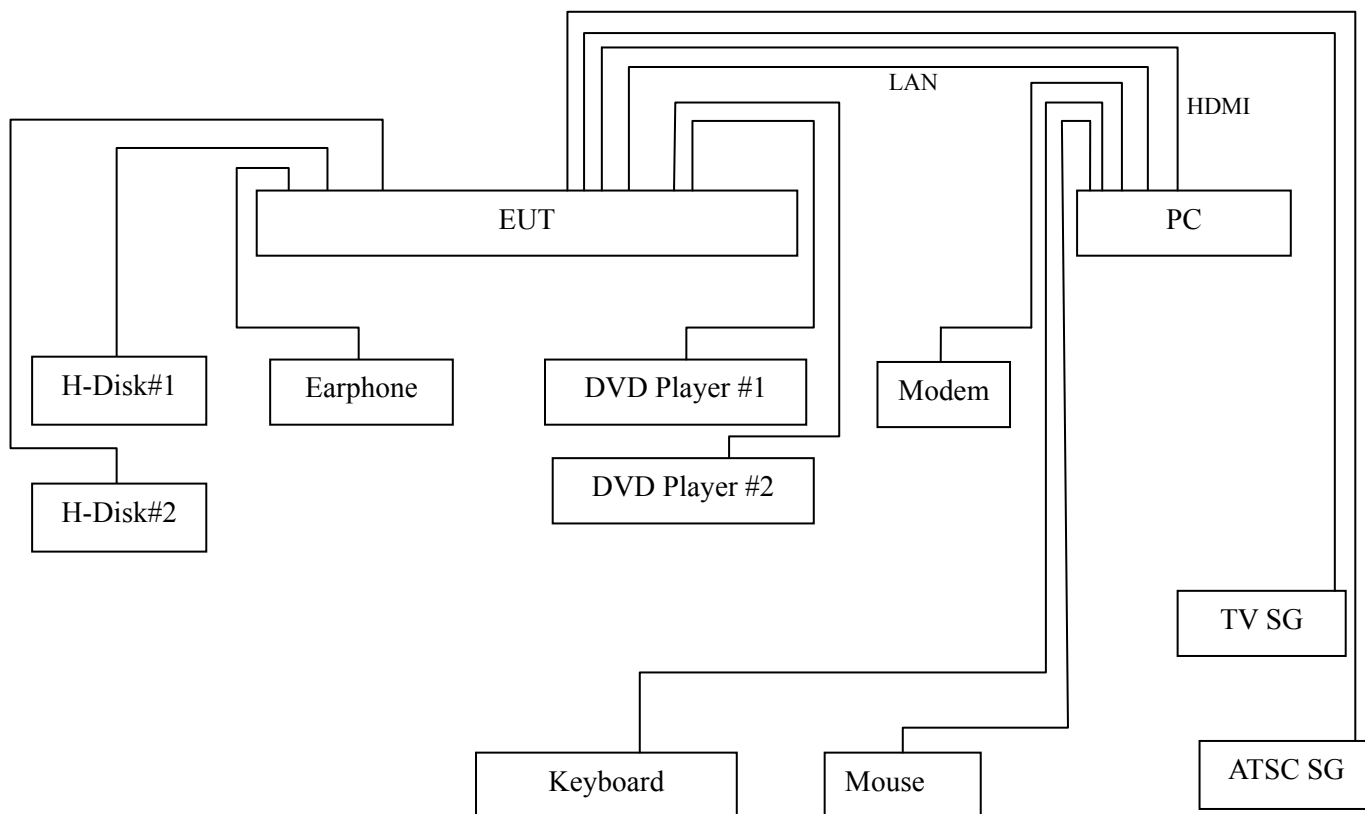

4.2.2 Test Setup

4.2.2.1 Below 1GHz

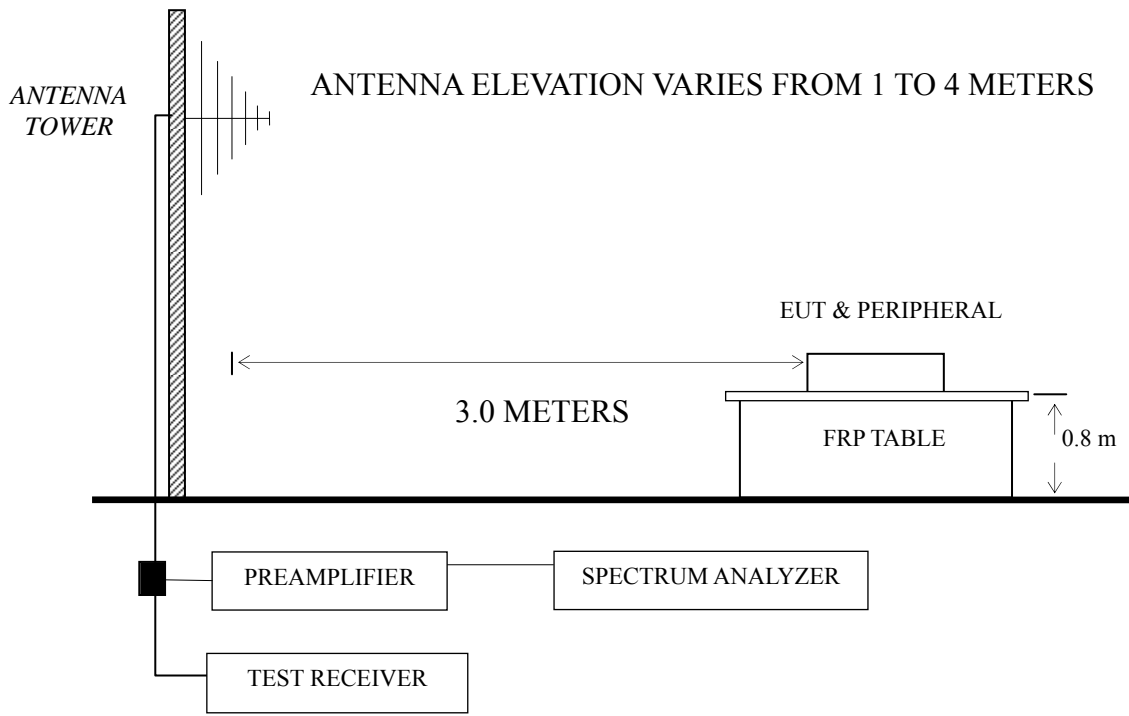

■ : 50 ohm Coaxial Switch

4.2.2.2 Above 1GHz

BORE-SIGHT ANTENNA TOWER

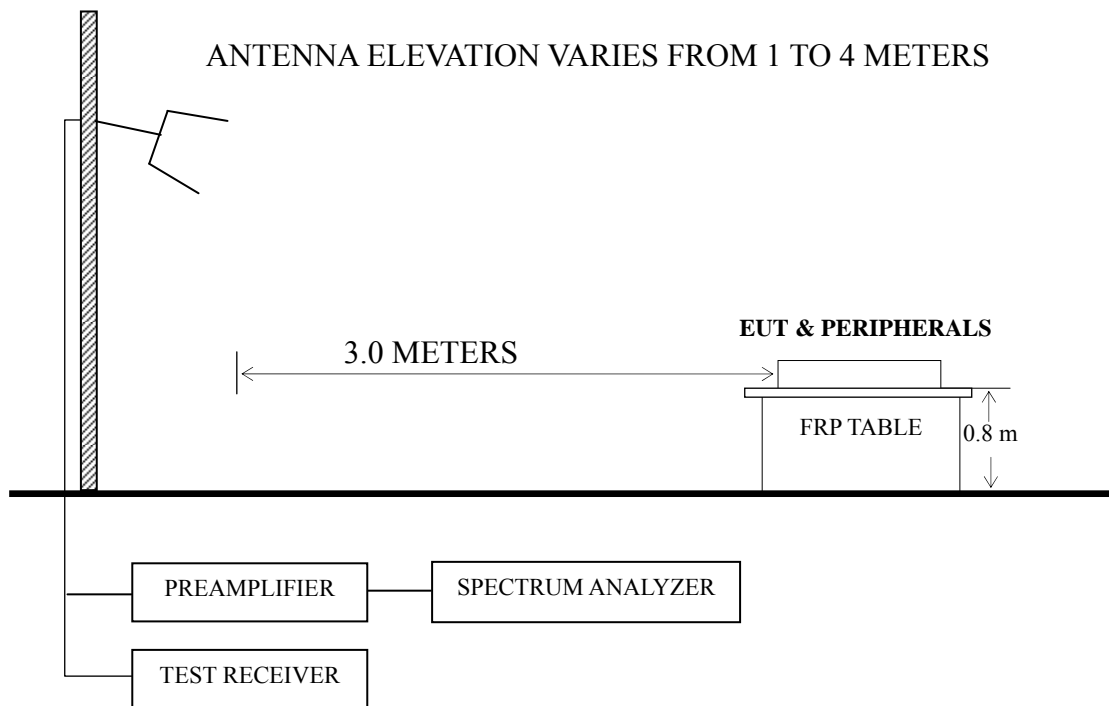

4.3 Radiated Emission Limit [FCC Part 15 Subpart B 15.109(a)]

Frequency (MHz)	Distance (m)	Field strength limits	
		($\mu\text{V/m}$)	dB ($\mu\text{V/m}$)
30 ~ 88	3	100	40.0
88 ~ 216	3	150	43.5
216 ~ 960	3	200	46.0
Above 960	3	500	54.0

NOTE 1 - Emission Level dB ($\mu\text{V/m}$) = 20 log Emission Level ($\mu\text{V/m}$)
NOTE 2 - The tighter limit applies at the band edges.
NOTE 3 - Distance refers to the distance in meters between the measuring instrument antenna and the closed point of any part of the device or system.
NOTE 4 - The limits shown are based on Quasi-peak value detector.
NOTE 5 - Above 1 GHz, the limit on peak emission is 20 dB above the maximum permitted average emission limit applicable to the EUT.

4.4 Test Configuration

The configuration of the EUT and peripherals are same as those used in conducted emission test.

Please refer to Sec.3.4.

4.5 Operating Condition of EUT

Same as conducted emission test which is listed in Sec.3.5, except for the test setup replaced by Sec.4.2.

4.6 Test Procedures

The EUT and peripherals were placed on a FRP turntable that is 0.8 meter above ground. The FRP turntable rotated 360 degrees to determine the position of the maximum emission level. The EUT was set 3 meters away from the receiving antenna, which was mounted on an antenna tower. Broadband antenna (Calibrated Bilog Antenna) was used as receiving antenna. The antenna moved up and down between 1 meter and 4 meters to find out the maximum emission level. Both horizontal and vertical polarizations of the antenna were set on measurement. In order to find the maximum emission, all of the interference cables were manipulated according to ANSI C63.4:2003 requirements during radiated emission test.

The I.F. bandwidth of Test Receiver R&S ESCI was set at 120 kHz.

The frequency range from 30 MHz to 1000MHz was checked for all test modes.

The frequency range from 1 GHz to 6 GHz was checked for the maximum resolution test mode.

The test modes were done on radiated disturbance test and all the test results are listed in Sec.4.7.

4.7 Test Results

<PASS>

The frequency and amplitude of the highest radiated emission relative the limit is reported. All the emissions not reported below are too low against the FCC limit.

Test Mode	Data Page
HDMI 1920*1080@60Hz & 1kHz playing	P24-P25
HDMI 1280*1024@60Hz & 1kHz playing	P26
HDMI 640*480@60Hz & 1kHz playing	P27
HDMI1080P	P28
USB Play	P29
LAN Play	P30

NOTE 1 – Emission Level = Antenna Factor + Cable Loss + Meter Reading.
($< 1\text{GHz}$);

Emission Level = Antenna Factor + Cable Loss – Preamp Factor
+ Meter Reading. ($> 1\text{GHz}$)

NOTE 2 – All readings are Quasi-Peak values below or equal to 1GHz, Peak and Average values above 1GHz.

NOTE 3 – 0° was the table front facing the antenna. Degree is calculated from 0° clockwise facing the antenna.

NOTE 4 – The worst case is for HDMI 1920*1080@60Hz & 1kHz playing test mode. The worst emission at horizontal polarization was detected at 797.000 MHz with corrected signal level of 44.55 dB ($\mu\text{V/m}$) (limit is 46.00 dB ($\mu\text{V/m}$)), when the antenna was 1.8 m height and the turntable was at 295° . The worst emission at vertical polarization was detected at 594.000 MHz with corrected signal level of 43.86 dB ($\mu\text{V/m}$) (limit is 46.00 dB ($\mu\text{V/m}$)), when the antenna was 1.2m height and the turntable was at 30° .

EUT : LED LCD TV Temperature : 22°C

Model No. : LC-40N5000U Humidity : 60%RH

Test Mode : HDMI 1920*1080@60Hz & 1kHz Playing Date of Test : Jan 13, 2016

Polarization	Frequency (MHz)	Meter Reading dB (μV)	Antenna Factor (dB/m)	Cable Loss (dB)	Preamp Factor (dB)	Emission Level dB (μV/m)	Limits dB (μV/m)	Margin (dB)	Remark
Horizontal	76.560	27.08	8.78	1.04	--	36.90	40.00	3.10	QP
	141.550	25.05	12.40	1.59	--	39.04	43.50	4.46	
	193.930	28.50	10.17	1.94	--	40.61	43.50	2.89	
	379.200	24.10	16.47	2.69	--	43.26	46.00	2.74	
	449.040	23.77	16.82	2.84	--	43.43	46.00	2.57	
	797.000	20.30	20.57	3.68	--	44.55	46.00	1.45	
	1690.434	55.34	26.40	4.07	35.44	50.37	74.00	23.63	PK
	2111.004	55.80	27.72	4.55	35.11	52.96	74.00	21.04	
	2547.974	58.81	28.63	4.96	35.16	57.24	74.00	16.76	
	2972.460	68.50	30.40	5.76	35.20	69.46	74.00	4.54	
	3375.707	58.74	31.27	6.10	34.83	61.28	74.00	12.72	
	4208.015	51.42	33.14	6.31	34.21	56.66	74.00	17.34	
	1690.434	36.19	26.40	4.07	35.44	31.22	54.00	22.78	AV
	2111.004	35.30	27.72	4.55	35.11	32.46	54.00	21.54	
	2547.974	39.06	28.63	4.96	35.16	37.49	54.00	16.51	
2972.460	47.56	30.40	5.76	35.20	48.52	54.00	5.48		
3375.707	39.49	31.27	6.10	34.83	42.03	54.00	11.97		
4208.015	30.40	33.14	6.31	34.21	35.64	54.00	18.36		

TEST ENGINEER: BILL WU

EUT : LED LCD TV Temperature : 22°C

Model No. : LC-40N5000U Humidity : 60%RH

Test Mode : HDMI 1920*1080@60Hz & 1kHz Playing Date of Test : Jan 13, 2016

Polarization	Frequency (MHz)	Meter Reading dB (μV)	Antenna Factor (dB/m)	Cable Loss (dB)	Preamp Factor (dB)	Emission Level dB (μV/m)	Limits dB (μV/m)	Margin (dB)	Remark
Vertical	31.940	16.56	17.50	0.65	--	34.71	40.00	5.29	QP
	76.560	25.01	8.78	1.04	--	34.83	40.00	5.17	
	151.250	23.48	11.43	1.65	--	36.56	43.50	6.94	
	396.660	20.55	16.57	2.71	--	39.83	46.00	6.17	
	594.000	22.70	18.85	2.31	--	43.86	46.00	2.14	
	788.540	17.07	20.50	3.66	--	41.23	46.00	4.77	PK
	1215.678	66.23	24.52	3.54	36.10	58.19	74.00	15.81	
	1705.647	59.18	26.45	4.09	35.42	54.30	74.00	19.70	
	2111.004	60.25	27.72	4.55	35.11	57.41	74.00	16.59	
	2547.974	64.72	28.63	4.96	35.16	63.15	74.00	10.85	
	2972.460	66.16	30.40	5.76	35.20	67.12	74.00	6.88	AV
	3393.901	57.56	31.31	6.10	34.81	60.16	74.00	13.84	
	1215.678	45.29	24.52	3.54	36.10	37.25	54.00	16.75	
	1705.647	40.87	26.45	4.09	35.42	35.99	54.00	18.01	
	2111.004	40.23	27.72	4.55	35.11	37.39	54.00	16.61	
2547.974	43.24	28.63	4.96	35.16	41.67	54.00	12.33		
2972.460	45.10	30.40	5.76	35.20	46.06	54.00	7.94		
3393.901	37.78	31.31	6.10	34.81	40.38	54.00	13.62		

TEST ENGINEER: BILL WU

EUT : LED LCD TV Temperature : 22°C

Model No. : LC-40N5000U Humidity : 60%RH

Test Mode : HDMI 1280*1024@60Hz & 1kHz Playing Date of Test : Jan 13, 2016

Polarization	Frequency (MHz)	Meter Reading dB (μV)	Antenna Factor (dB/m)	Cable Loss (dB)	Emission Level dB (μV/m)	Limits dB (μV/m)	Margin (dB)
Horizontal	76.560	22.85	8.78	1.04	32.67	40.00	7.33
	127.000	24.44	12.97	1.51	38.92	43.50	4.58
	290.930	24.42	13.60	2.52	40.54	46.00	5.46
	388.900	23.89	16.50	2.71	43.10	46.00	2.90
	544.100	18.47	18.62	2.63	39.72	46.00	6.28
	795.880	19.20	20.57	3.68	43.45	46.00	2.55
Vertical	31.940	18.08	17.50	0.65	36.23	40.00	3.77
	76.560	27.16	8.78	1.04	36.98	40.00	3.02
	127.000	23.80	12.97	1.51	38.28	43.50	5.22
	398.600	20.00	16.58	2.71	39.29	46.00	6.71
	540.000	20.00	18.50	2.68	41.18	46.00	4.82
	794.360	17.14	20.53	3.68	41.35	46.00	4.65

TEST ENGINEER: BILL WU

EUT : LED LCD TV Temperature : 22°C

Model No. : LC-40N5000U Humidity : 60%RH

Test Mode : HDMI 640*480@60Hz & 1kHz Playing Date of Test : Jan 13, 2016

Polarization	Frequency (MHz)	Meter Reading dB (μV)	Antenna Factor (dB/m)	Cable Loss (dB)	Emission Level dB (μV/m)	Limits dB (μV/m)	Margin (dB)
Horizontal	76.560	21.90	8.78	1.04	31.72	40.00	8.28
	126.030	21.37	13.03	1.50	35.90	43.50	7.60
	202.660	27.88	9.75	1.98	39.61	43.50	3.89
	296.750	24.78	13.70	2.56	41.04	46.00	4.96
	381.140	23.45	16.50	2.69	42.64	46.00	3.36
	798.000	18.30	20.57	3.68	42.55	46.00	3.45
Vertical	34.850	17.43	15.80	0.68	33.91	40.00	6.09
	76.560	25.87	8.78	1.04	35.69	40.00	4.31
	154.160	25.92	11.24	1.66	38.82	43.50	4.68
	399.570	19.80	16.60	2.72	39.12	46.00	6.88
	602.300	18.44	19.10	2.26	39.80	46.00	6.20
	791.450	16.55	20.50	3.68	40.73	46.00	5.27

TEST ENGINEER: BILL WU

EUT : LED LCD TV Temperature : 22°C

Model No. : LC-40N5000U Humidity : 60%RH

Test Mode : HDMI1080P Date of Test : Jan 13, 2016

Polarization	Frequency (MHz)	Meter Reading dB (μ V)	Antenna Factor (dB/m)	Cable Loss (dB)	Emission Level dB (μ V/m)	Limits dB (μ V/m)	Margin (dB)
Horizontal	76.560	23.20	8.78	1.04	33.02	40.00	6.98
	151.250	23.50	11.43	1.65	36.58	43.50	6.92
	396.660	19.56	16.57	2.71	38.84	46.00	7.16
	742.420	15.30	19.97	3.60	38.87	46.00	7.13
	797.000	15.20	20.57	3.68	39.45	46.00	6.55
	890.900	13.80	21.30	4.46	39.56	46.00	6.44
Vertical	31.940	14.95	17.50	0.65	33.10	40.00	6.90
	75.590	24.18	8.61	1.02	33.81	40.00	6.19
	151.250	24.26	11.43	1.65	37.34	43.50	6.16
	399.570	20.28	16.60	2.72	39.60	46.00	6.40
	803.090	14.71	20.60	3.78	39.09	46.00	6.91
	891.000	12.30	21.30	4.46	38.06	46.00	7.94

TEST ENGINEER: BILL WU

EUT : LED LCD TV Temperature : 22°C

Model No. : LC-40N5000U Humidity : 60%RH

Test Mode : USB Play Date of Test : Jan 13, 2016

Polarization	Frequency (MHz)	Meter Reading dB (μ V)	Antenna Factor (dB/m)	Cable Loss (dB)	Emission Level dB (μ V/m)	Limits dB (μ V/m)	Margin (dB)
Horizontal	132.820	21.93	12.69	1.54	36.16	43.50	7.34
	151.250	23.46	11.43	1.65	36.54	43.50	6.96
	304.510	23.36	13.95	2.60	39.91	46.00	6.09
	379.200	20.11	16.47	2.69	39.27	46.00	6.73
	401.510	20.66	16.60	2.72	39.98	46.00	6.02
	794.360	15.22	20.53	3.68	39.43	46.00	6.57
Vertical	30.970	14.34	18.15	0.64	33.13	40.00	6.87
	76.560	22.94	8.78	1.04	32.76	40.00	7.24
	136.700	21.75	12.57	1.56	35.88	43.50	7.62
	376.290	20.23	16.41	2.69	39.33	46.00	6.67
	597.450	17.57	18.98	2.31	38.86	46.00	7.14
	803.090	15.53	20.60	3.78	39.91	46.00	6.09

TEST ENGINEER: BILL WU

EUT : LED LCD TV Temperature : 22°C

Model No. : LC-40N5000U Humidity : 60%RH

Test Mode : LAN Play Date of Test : Jan 13, 2016

Polarization	Frequency (MHz)	Meter Reading dB (μ V)	Antenna Factor (dB/m)	Cable Loss (dB)	Emission Level dB (μ V/m)	Limits dB (μ V/m)	Margin (dB)
Horizontal	126.030	21.21	13.03	1.50	35.74	43.50	7.76
	151.250	23.74	11.43	1.65	36.82	43.50	6.68
	304.510	22.94	13.95	2.60	39.49	46.00	6.51
	401.510	20.03	16.60	2.72	39.35	46.00	6.65
	794.360	14.87	20.53	3.68	39.08	46.00	6.92
	895.240	14.16	21.30	4.46	39.92	46.00	6.08
Vertical	74.620	26.12	8.43	1.01	35.56	40.00	4.44
	124.090	24.25	13.04	1.49	38.78	43.50	4.72
	151.250	25.36	11.43	1.65	38.44	43.50	5.06
	399.000	21.01	16.58	2.71	40.30	46.00	5.70
	449.040	21.79	16.82	2.84	41.45	46.00	4.55
	745.860	16.91	20.03	3.62	40.56	46.00	5.44

TEST ENGINEER: BILL WU

6 DEVIATION TO TEST SPECIFICATIONS

None.