

Application for FCC Certificate
On Behalf of
Hisense Electric Co., Ltd.

LCD TV

Model No.	Serial No.	Brand
LTDN42V68US	--	Hisense
		Emerson
LCD42V68PCA	E2010090601	Hisense

FCC ID : W9HLCDD0005

Prepared For : Hisense Electric Co., Ltd.
No.218 Qianwangang Road, Economy & Technology
Development Zone, Qingdao, China

Prepared By : Audix Technology (Shanghai) Co., Ltd.
3F 34Bldg 680 Guiping Rd,
Caohejing Hi-Tech Park,
Shanghai 200233, China

Tel: +86-21-64955500
Fax: +86-21-64955491

Report No. : ACI-F10093A1
Date of Test : Sep 06-08, 2010
Date of Report : Sep 14, 2010

TABLE OF CONTENTS

	Page
1 SUMMARY OF STANDARDS AND RESULTS.....	4
1.1 Description of Standards and Results.....	4
2 GENERAL INFORMATION.....	5
2.1 Description of Equipment Under Test.....	5
2.2 Peripherals.....	7
2.3 Description of Test Facility.....	8
2.4 Measurement Uncertainty.....	8
3 CONDUCTED EMISSION TEST.....	9
3.1 Test Equipment.....	9
3.2 Block Diagram of Test Setup.....	9
3.3 Conducted Emission Limit [FCC Part 15 Subpart B 15.107(a)].....	10
3.4 Test Configuration.....	10
3.5 Operating Condition of EUT.....	11
3.6 Test Procedures.....	11
3.7 Test Results.....	12
4 RADIATED EMISSION TEST.....	19
4.1 Test Equipment.....	19
4.2 Block Diagram of Test Setup.....	19
4.3 Radiated Emission Limit [FCC Part 15 Subpart B 15.109(a)].....	20
4.4 Test Configuration.....	20
4.5 Operating Condition of EUT.....	20
4.6 Test Procedures.....	21
4.7 Test Results.....	21
5 DEVIATION TO TEST SPECIFICATIONS.....	28
6 DEBUG DESCRIPTION.....	29

TEST REPORT FOR FCC CERTIFICATE

Applicant : Hisense Electric Co., Ltd.
 Manufacturer : Hisense Electric Co., Ltd.
 EUT Description : LCD TV

Model No.	Serial No.	Brand	Power Supply
LTDN42V68US	--	Hisense	120V/60Hz
		Emerson	
LCD42V68PCA	E2010090601	Hisense	

Test Procedure Used:

*FCC RULES AND REGULATIONS PART 15 SUBPART B CLASS B OCTOBER 2009
AND ANSI C63.4-2003*

The device described above is tested by Audix Technology (Shanghai) Co., Ltd. to determine the maximum emission levels emanating from the device. The maximum emission levels are compared to the FCC Part 15 Subpart B (Class B) limits both radiated and conducted emissions.

The test results are contained in this test report and Audix Technology (Shanghai) Co., Ltd. is assumed full responsibility for the accuracy and completeness of these measurements. This report shows that the EUT (M/N: Refer to Sec.2.1; S/N: Refer to Sec.2.1) which was tested in 3m anechoic chamber Sep 06-08, 2010 is technically compliance with the FCC official limits also.

This report applies to above tested sample only. This report shall not be reproduced in part without written approval of Audix Technology (Shanghai) Co., Ltd.

This report contains data that are not covered by the NVLAP accreditation.

This report must not be used by the client to claim product certification, approval, or endorsement by NVLAP, NIST, or any agency of the federal government.

The test results for EUT's TV functions are contained in No.F10094A1, a Verification report.

Date of Test : Sep 06-08, 2010 Date of Report : Sep 14, 2010

Producer : 
CANDY XI / Assistant

Review : 
DIO YANG / Deputy Assistant Manager

AUDIX[®] For and on behalf of
Audix Technology (Shanghai) Co., Ltd.

Signatory : 
Authorized Signature EMC SAMMY CHEN / Deputy Manager

1 SUMMARY OF STANDARDS AND RESULTS

1.1 Description of Standards and Results

The EUT have been tested according to the applicable standards as referenced below:

Description of Test Item	Standard	Limits	Results
EMISSION			
Conducted Disturbance at the Mains Terminal	FCC RULES AND REGULATIONS PART 15 SUBPART B OCTOBER 2009 AND ANSI C63.4-2003	15.107(a) Class B	Pass
Radiated Disturbance	FCC RULES AND REGULATIONS PART 15 SUBPART B OCTOBER 2009 AND ANSI C63.4-2003	15.109(a) Class B	Pass

2 GENERAL INFORMATION

2.1 Description of Equipment Under Test

Description : LCD TV

Type of EUT : Production Pre-product Pro-type

Model No.	Serial No.	Brand
LTDN42V68US	--	Hisense
LCD42V68PCA	E2010090601	Hisense

Note 1 : The different list for all the models are as follows:

Report No.	Model No.	Rev. Summary	Edition No.	Data of Rev.
ACI-F10093	LTDN42V68US	Original Report.	0	Aug 03, 2010
ACI-F10093A1	LTDN42V68US, LCD42V68PCA	To add a new model number and main board	Rev. A1	Sep 14, 2010

Note 2 : The above models are all the same except for the different model number and brand.

Note 3 : The LCD42V68PCA was tested and recorded in this report.

Applicant : Hisense Electric Co., Ltd.
No.218 Qianwangang Road, Economy &
Technology Development Zone, Qingdao, China

Manufacturer : Hisense Electric Co., Ltd.
No.218 Qianwangang Road, Economy &
Technology Development Zone, Qingdao, China

LCD Panel : Manufacturer : Hisense Electric Co., Ltd.
M/N : HC420EF-E01

Max Resolution : 1024*768@60Hz

D-Sub Cable : Shielded, Detachable, 1.85m,
with two cores on cable

HDMI Cable : Shielded, Detachable, 1.85m,
without core on cable

Power Cord : Unshielded, Detachable, 1.80m

Remark:

The EUT is a LCD TV which input/output ports as follows:

Side Port:

- (1) One HDMI1 Port : Connected with DVD #1
- (2) One Earphone Port : Connected with Earphone
- (3) One VGA Port : Connected with PC
- (4) One VGA Audio Port: : Connected with PC
- (5) One ANT Port : Connected with ATSC SG/TV SG
- (6) One Service (USB) Port : Do not open to customer

Back Port

- (7) One HDMI2 Port : Connected with PC
- (8) One Component of AV Port : Connected with DVD #1
- (9) One Component of YPbPr Port : Connected with DVD #2
- (10) One Component of YPbPr Audio Port : Connected with DVD #2
- (11) One Digital Audio Out Port: : Connected with DVD #2

2.2 Peripherals

2.2.1 PC

Manufacturer : HP
Model Number : dx7200MT
Serial Number : CNG8130K89
Power Cord : Unshielded, Detachable, 1.8m
Certificate : FCC DoC; CE/EMC; VCCI; C-Tick; UL
BSMI (R33001) 3C (A000111)
MIC (E-A011-04-2659(B))

2.2.2 Printer

Manufacturer : HP
Model Number : C3990A
Serial Number : JPZX020487
Data Cable : Shielded, detachable, 1.5m
Certificate : GS, CE/EMC, C-Tick, FCC DoC

2.2.3 Keyboard

Manufacturer : Microsoft
Model Number : RT2300
Serial Number : 7668200662248
Data Cable : Shielded, undetachable, 1.8m
Certificate : CE/EMC, FCC DoC, VCCI, MIC, C-Tick,
BSMI

2.2.4 Mouse

Manufacturer : Microsoft
Model Number : RT2300
Serial Number : 6965712071551
Data Cable : Shielded, undetachable, 1.8m.
Certificate : CE/EMC, FCC DoC, VCCI, MIC, C-Tick,
BSMI

2.2.5 Modem

Manufacturer : TP-LINK
Model Number : TM-EC5658V
Serial Number : 07123301053
Data Cable : Shielded, Detachable, 1.8m
Certificate : FCC DoC, CE/EMC, CCC

2.2.6 Earphone

Manufacturer : SONY
Model Number : MDR-E808
Serial Number : 1808030805305506

2.2.7 TV Signal Generator

Manufacturer : FLUKE
Model Number : 54200m01
Serial Number : 814008
Data Cable : Shielded, detachable, 2.0m
Power Cord : Unshielded, detachable, 2.0m
Certificate : CE/EMC, FCC DoC, CCC

2.2.8 ATSC Signal Generator

Manufacturer : SENCORE
Model Number : ATSC997
Serial Number : 6790071

2.2.9 DVD #1

Manufacturer : PHILIPS
Model Number : DVP3986K/93
Serial Number : KX1A0902120108
Certificate : FCC DoC, CE/EMC, CCC

2.2.10 DVD#2

Manufacturer : LG
Model Number : DF9921N
Serial Number : 3850R-M846W
Certificate : FCC DoC, CE/EMC, CCC

2.2.11 Speaker

Manufacturer : DIBA
Model Number : FS-04
Serial Number : 002

2.3 Description of Test Facility

Site Description (No.3 3m Chamber) : Sept. 17, 1998 file on
Apr 29, 2009 Renewed
Federal Communications Commission
FCC Engineering Laboratory
7435 Oakland Mills Road
Columbia, MD 21046, USA

Name of Firm : Audix Technology (Shanghai) Co., Ltd.

Site Location : 3F 34Bldg 680 Guiping Rd,
Caohejing Hi-Tech Park,
Shanghai 200233, China

NVLAP Lab Code : 200371-0

2.4 Measurement Uncertainty

Conducted Emission Expanded Uncertainty: U = 1.26 dB
Radiated Emission Expanded Uncertainty : U = 3.02 dB

3 CONDUCTED EMISSION TEST

3.1 Test Equipment

The following test equipments are used during the conducted emission test in a shielded room:

Item	Type	Manufacturer	Model No.	Serial No.	Last Cal.	Next Cal.
1.	Test Receiver	R&S	ESCI	100841	Oct 15, 2009	Oct 15, 2010
2.	Artificial Mains Network (AMN)	R&S	ESH2-Z5	843890/011	Apr 02, 2010	Apr 02, 2011
3.	Line Impedance Stabilization Network (LISN)	Kyoritsu	KNW-407	8-1280-4	Apr 02, 2010	Apr 02, 2011
4.	50 Ω Coaxial Switch	Anritsu	MP59B	6200426389	Mar 19, 2010	Sep 19, 2010
5.	50 Ω Terminator	Anritsu	BNC	001	Apr 02, 2010	Apr 02, 2011
6.	Software	Audix	E3	SET00200 9804M592	--	--

3.2 Block Diagram of Test Setup

3.2.1 EUT & Peripherals

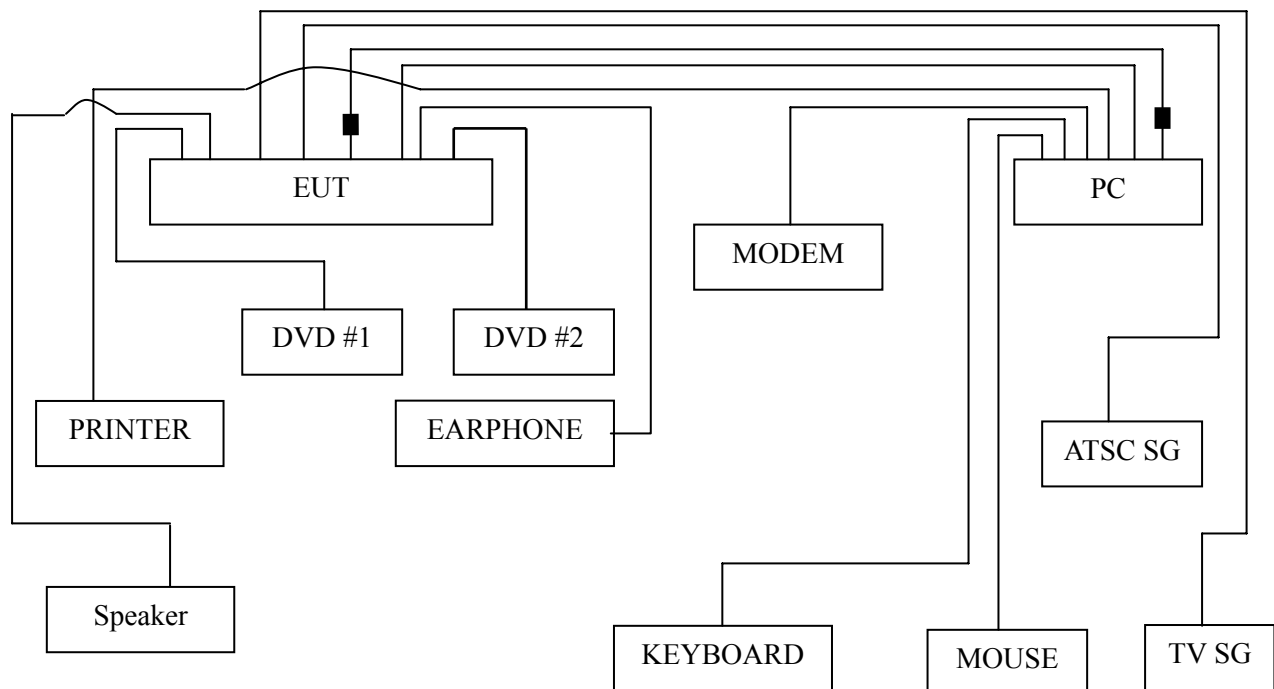

■ : Ferrite core

3.2.2 Conducted Disturbance Test Setup

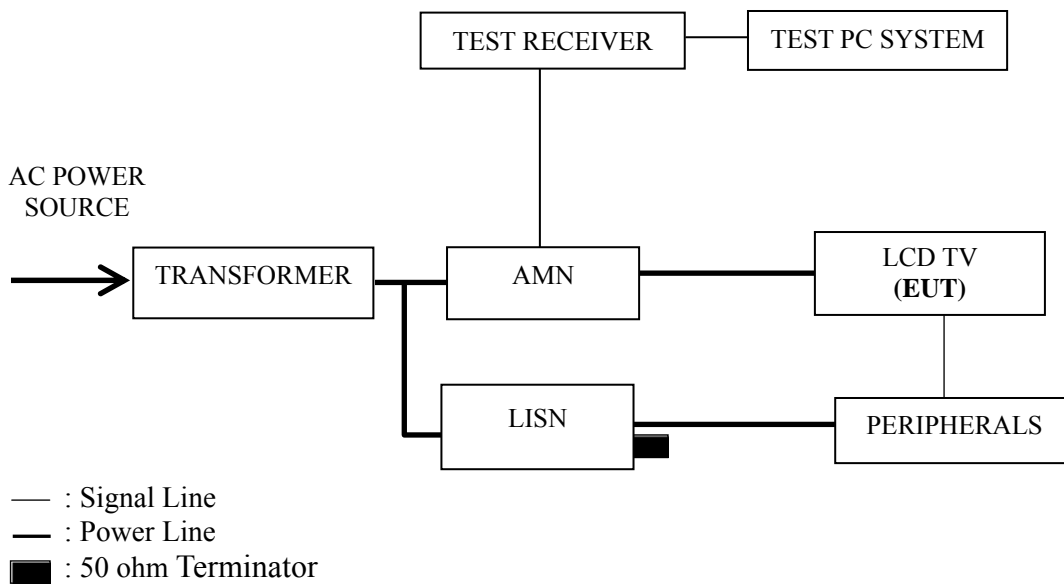

3.3 Conducted Emission Limit [FCC Part 15 Subpart B 15.107(a)]

Frequency Range (MHz)	Limits dB (μ V)	
	Quasi-peak	Average
0.15 ~ 0.5	66~56	56~46
0.5 ~ 5	56	46
5 ~ 30	60	50

NOTE 1 – The lower limit shall apply at the transition frequencies.
 NOTE 2 – The limit decreases linearly with the logarithm of the frequency in the range 0.15 MHz~0.50 MHz

3.4 Test Configuration

The EUT (listed in Sec.2.1) and the peripherals (listed in Sec 2.2) were installed as shown on Sec.3.2 to meet FCC requirement and operating in a manner that tends to maximize its emission level in a normal application.

3.5 Operating Condition of EUT

3.5.1 Setup the EUT and peripherals as shown in Sec. 3.2.

3.5.2 Turn on the power of all equipments and the EUT.

3.5.3 Set the contrast & brightness of EUT to maximum.

3.5.4 PC system ran the self-test program “EMC Test” by windows XP and sent “H” characters to EUT through graphic card, the EUT’s screen displayed and filled with “H” pattern by its resolution (Via D-Sub & HDMI Input).

3.5.5 Repeat above procedure 3.5.4 for difference test mode.

3.5.6 The other peripherals devices were driven and operated during the test.

3.5.7 The test modes are as follows:

Test Mode
D-Sub 640*480@60Hz
D-Sub 800*600@60Hz
D-Sub 1024*768@60Hz
HDMI 640*480@60Hz
HDMI 800*600@60Hz
HDMI 1024*768@60Hz

3.6 Test Procedures

The EUT and peripherals were connected to the power mains through an Artificial Mains Network (AMN). This provided a 50 ohm coupling impedance for the measuring equipment.

Both sides of AC line (Line & Neutral) were checked for maximum conducted interference. In order to find the maximum emission, the relative positions of equipment and all of the interface cables were changed or manipulated according to ANSI C63.4:2003 during conducted emission test.

The bandwidth of R&S Test Receiver ESCI was set at 9 kHz.

The frequency range from 150 kHz to 30 MHz was checked.

The test modes were done on conducted disturbance test and all the test results are listed in Sec. 3.7.

3.7 Test Results

< **PASS** >

The frequency and amplitude of the highest conducted emission relative to the limit is reported. All emissions not reported below are too low against the prescribed limits.

Test Mode	Data Page
D-Sub 640*480@60Hz	P13
D-Sub 800*600@60Hz	P14
D-Sub 1024*768@60Hz	P15
HDMI 640*480@60Hz	P16
HDMI 800*600@60Hz	P17
HDMI 1024*768@60Hz	P18

NOTE 1 – Factor = Cable Loss + AMN Factor.

NOTE 2 – Emission Level = Meter Reading + Factor.

NOTE 3 – “QP” means “Quasi-Peak” values, “AV” means “Average” values.

NOTE 4 – The worst case is for HDMI 1024*768@60Hz test mode. The worst emission is detected at 1.403 MHz (Quasi-Peak value) with corrected signal level of 43.73 dB (μV) (limit is 56.00 dB (μV)), when the Neutral of the EUT is connected to AMN.

EUT : LCD TV Temperature : 22°C

Model No. : LCD42V68PCA Humidity : 48%RH

Serial No. : E2010090601 Date of Test : Sep 06, 2010

Test Mode : D-Sub 640*480@60Hz

Test Line	Frequency (MHz)	Meter Reading dB(μ V)	Factor (dB)	Emission Level dB(μ V)	Limits dB(μ V)	Margin (dB)	Remark
Line	0.156	47.27	0.37	47.64	65.65	18.01	QP
	0.259	43.20	0.42	43.62	61.47	17.85	
	0.679	39.91	0.52	40.43	56.00	15.57	
	1.464	38.74	0.57	39.31	56.00	16.69	
	15.388	35.65	1.28	36.93	60.00	23.07	
	20.377	38.78	1.63	40.41	60.00	19.59	
	0.156	23.65	0.37	24.02	55.65	31.63	AV
	0.259	32.64	0.42	33.06	51.47	18.41	
	0.679	23.15	0.52	23.67	46.00	22.33	
	1.464	28.54	0.57	29.11	46.00	16.89	
	15.388	25.64	1.28	26.92	50.00	23.08	
	20.377	25.54	1.63	27.17	50.00	22.83	
Neutral	0.157	46.78	0.32	47.10	65.60	18.50	QP
	0.679	41.82	0.49	42.31	56.00	13.69	
	1.310	39.75	0.54	40.29	56.00	15.71	
	6.878	35.67	0.86	36.53	60.00	23.47	
	11.559	36.78	1.18	37.96	60.00	22.04	
	15.885	37.54	1.52	39.06	60.00	20.94	
	0.157	32.61	0.32	32.93	55.60	22.67	AV
	0.679	31.26	0.49	31.75	46.00	14.25	
	1.310	23.53	0.54	24.07	46.00	21.93	
	6.878	25.63	0.86	26.49	50.00	23.51	
	11.559	26.53	1.18	27.71	50.00	22.29	
	15.885	25.47	1.52	26.99	50.00	23.01	

TEST ENGINEER: WENCY YANG

EUT : LCD TV Temperature : 22°C

Model No. : LCD42V68PCA Humidity : 48%RH

Serial No. : E2010090601 Date of Test : Sep 06, 2010

Test Mode : D-Sub 800*600@60Hz

Test Line	Frequency (MHz)	Meter Reading dB(μ V)	Factor (dB)	Emission Level dB(μ V)	Limits dB(μ V)	Margin (dB)	Remark
Line	0.155	47.35	0.37	47.72	65.74	18.02	QP
	0.262	43.82	0.42	44.24	61.38	17.14	
	0.471	40.51	0.51	41.02	56.49	15.47	
	0.679	39.31	0.52	39.83	56.00	16.17	
	1.464	40.11	0.57	40.68	56.00	15.32	
	20.594	37.04	1.65	38.69	60.00	21.31	
	0.155	32.16	0.37	32.53	55.74	23.21	AV
	0.262	23.64	0.42	24.06	51.38	27.32	
	0.471	31.20	0.51	31.71	46.49	14.78	
	0.679	21.51	0.52	22.03	46.00	23.97	
	1.464	23.64	0.57	24.21	46.00	21.79	
	20.594	24.56	1.65	26.21	50.00	23.79	
Neutral	0.156	47.90	0.32	48.22	65.65	17.43	QP
	0.262	45.38	0.35	45.73	61.38	15.65	
	0.679	40.80	0.49	41.29	56.00	14.71	
	1.403	42.97	0.54	43.51	56.00	12.49	
	7.935	38.02	0.92	38.94	60.00	21.06	
	16.839	39.69	1.58	41.27	60.00	18.73	
	0.156	23.64	0.32	23.96	55.65	31.69	AV
	0.262	26.55	0.35	26.90	51.38	24.48	
	0.679	30.26	0.49	30.75	46.00	15.25	
	1.403	31.25	0.54	31.79	46.00	14.21	
	7.935	25.14	0.92	26.06	50.00	23.94	
	16.839	26.51	1.58	28.09	50.00	21.91	

TEST ENGINEER: WENCY YANG

EUT : LCD TV Temperature : 22°C

Model No. : LCD42V68PCA Humidity : 48%RH

Serial No. : E2010090601 Date of Test : Sep 06, 2010

Test Mode : D-Sub 1024*768@60Hz

Test Line	Frequency (MHz)	Meter Reading dB(μ V)	Factor (dB)	Emission Level dB(μ V)	Limits dB(μ V)	Margin (dB)	Remark
Line	0.161	46.43	0.38	46.81	65.43	18.62	QP
	0.262	43.79	0.42	44.21	61.38	17.17	
	0.573	41.25	0.52	41.77	56.00	14.23	
	1.249	39.12	0.55	39.67	56.00	16.33	
	2.033	38.01	0.61	38.62	56.00	17.38	
	14.364	39.46	1.23	40.69	60.00	19.31	
	0.161	32.15	0.38	32.53	55.43	22.90	AV
	0.262	32.64	0.42	33.06	51.38	18.32	
	0.573	23.61	0.52	24.13	46.00	21.87	
	1.249	23.65	0.55	24.20	46.00	21.80	
2.033	28.61	0.61	29.22	46.00	16.78		
14.364	26.34	1.23	27.57	50.00	22.43		
Neutral	0.157	48.83	0.32	49.15	65.60	16.45	QP
	0.259	42.54	0.35	42.89	61.47	18.58	
	0.573	41.19	0.49	41.68	56.00	14.32	
	0.989	42.33	0.51	42.84	56.00	13.16	
	1.403	41.19	0.54	41.73	56.00	14.27	
	17.568	40.43	1.63	42.06	60.00	17.94	
	0.157	23.64	0.32	23.96	55.60	31.64	AV
	0.259	32.64	0.35	32.99	51.47	18.48	
	0.573	23.64	0.49	24.13	46.00	21.87	
	0.989	23.64	0.51	24.15	46.00	21.85	
1.403	32.61	0.54	33.15	46.00	12.85		
17.568	32.15	1.63	33.78	50.00	16.22		

TEST ENGINEER: WENCY YANG

EUT : LCD TV Temperature : 22°C

Model No. : LCD42V68PCA Humidity : 48%RH

Serial No. : E2010090601 Date of Test : Sep 06, 2010

Test Mode : HDMI 640*480@60Hz

Test Line	Frequency (MHz)	Meter Reading dB(μ V)	Factor (dB)	Emission Level dB(μ V)	Limits dB(μ V)	Margin (dB)	Remark
Line	0.161	46.11	0.38	46.49	65.43	18.94	QP
	0.363	41.60	0.47	42.07	58.65	16.58	
	0.573	40.80	0.52	41.32	56.00	14.68	
	1.610	38.26	0.58	38.84	56.00	17.16	
	14.364	39.89	1.23	41.12	60.00	18.88	
	17.849	37.02	1.47	38.49	60.00	21.51	
	0.161	32.01	0.38	32.39	55.43	23.04	AV
	0.363	30.24	0.47	30.71	48.65	17.94	
	0.573	30.74	0.52	31.26	46.00	14.74	
	1.610	28.54	0.58	29.12	46.00	16.88	
	14.364	28.51	1.23	29.74	50.00	20.26	
	17.849	27.84	1.47	29.31	50.00	20.69	
Neutral	0.150	47.06	0.32	47.38	66.00	18.62	QP
	0.172	47.06	0.31	47.37	64.86	17.49	
	0.363	43.19	0.43	43.62	58.65	15.03	
	0.573	42.49	0.49	42.98	56.00	13.02	
	1.403	41.80	0.54	42.34	56.00	13.66	
	18.820	39.76	1.71	41.47	60.00	18.53	
	0.150	32.01	0.32	32.33	56.00	23.67	AV
	0.172	30.45	0.31	30.76	54.86	24.10	
	0.363	30.23	0.43	30.66	48.65	17.99	
	0.573	30.54	0.49	31.03	46.00	14.97	
	1.403	20.47	0.54	21.01	46.00	24.99	
	18.820	28.13	1.71	29.84	50.00	20.16	

TEST ENGINEER: WENCY YANG

EUT : LCD TV Temperature : 22°C

Model No. : LCD42V68PCA Humidity : 48%RH

Serial No. : E2010090601 Date of Test : Sep 06, 2010

Test Mode : HDMI 800*600@60Hz

Test Line	Frequency (MHz)	Meter Reading dB(μ V)	Factor (dB)	Emission Level dB(μ V)	Limits dB(μ V)	Margin (dB)	Remark	
Line	0.150	47.28	0.37	47.65	66.00	18.35	QP	
	0.172	47.23	0.37	47.60	64.86	17.26		
	0.573	42.43	0.52	42.95	56.00	13.05		
	1.403	43.13	0.57	43.70	56.00	12.30		
	2.033	40.83	0.61	41.44	56.00	14.56		
	17.849	40.01	1.47	41.48	60.00	18.52		
	0.150	32.05	0.37	32.42	56.00	23.58	AV	
	0.172	33.49	0.37	33.86	54.86	21.00		
	0.573	32.15	0.52	32.67	46.00	13.33		
	1.403	28.64	0.57	29.21	46.00	16.79		
	2.033	30.27	0.61	30.88	46.00	15.12		
	17.849	30.24	1.47	31.71	50.00	18.29		
	Neutral	0.180	45.86	0.31	46.17	64.50	18.33	QP
		0.363	43.71	0.43	44.14	58.65	14.51	
0.573		41.34	0.49	41.83	56.00	14.17		
0.779		40.51	0.50	41.01	56.00	14.99		
1.403		42.38	0.54	42.92	56.00	13.08		
18.426		40.06	1.68	41.74	60.00	18.26		
0.180		32.64	0.31	32.95	54.50	21.55	AV	
0.363		28.50	0.43	28.93	48.65	19.72		
0.573		28.12	0.49	28.61	46.00	17.39		
0.779		30.21	0.50	30.71	46.00	15.29		
1.403		23.14	0.54	23.68	46.00	22.32		
18.426		23.15	1.68	24.83	50.00	25.17		

TEST ENGINEER: WENCY YANG

EUT : LCD TV Temperature : 22°C

Model No. : LCD42V68PCA Humidity : 48%RH

Serial No. : E2010090601 Date of Test : Sep 06, 2010

Test Mode : HDMI 1024*768@60Hz

Test Line	Frequency (MHz)	Meter Reading dB(μ V)	Factor (dB)	Emission Level dB(μ V)	Limits dB(μ V)	Margin (dB)	Remark
Line	0.161	47.33	0.38	47.71	65.43	17.72	QP
	0.262	42.74	0.42	43.16	61.38	18.22	
	0.679	40.01	0.52	40.53	56.00	15.47	
	1.610	38.14	0.58	38.72	56.00	17.28	
	14.364	40.57	1.23	41.80	60.00	18.20	
	17.849	37.33	1.47	38.80	60.00	21.20	
	AV	0.161	32.51	0.38	32.89	55.43	22.54
		0.262	32.12	0.42	32.54	51.38	18.84
		0.679	23.64	0.52	24.16	46.00	21.84
		1.610	25.46	0.58	26.04	46.00	19.96
14.364		23.64	1.23	24.87	50.00	25.13	
17.849		23.64	1.47	25.11	50.00	24.89	
Neutral	0.161	47.81	0.32	48.13	65.43	17.30	QP
	0.363	42.75	0.43	43.18	58.65	15.47	
	0.573	42.88	0.49	43.37	56.00	12.63	
	1.403	43.19	0.54	43.73	56.00	12.27	
	2.594	38.58	0.63	39.21	56.00	16.79	
	18.426	39.95	1.68	41.63	60.00	18.37	
	AV	0.161	32.12	0.32	32.44	55.43	22.99
		0.363	23.53	0.43	23.96	48.65	24.69
		0.573	32.21	0.49	32.70	46.00	13.30
		1.403	23.64	0.54	24.18	46.00	21.82
2.594		28.54	0.63	29.17	46.00	16.83	
18.426		28.54	1.68	30.22	50.00	19.78	

TEST ENGINEER: WENCY YANG

4 RADIATED EMISSION TEST

4.1 Test Equipment

The following test equipments are used during the radiated emission test in a semi-anechoic chamber:

Item	Type	Manufacturer	Model No.	Serial No.	Last Cal.	Next Cal.
1.	Test Receiver	R&S	ESVS10	844594/001	Mar 07, 2010	Mar 07, 2011
2.	Preamplifier	Agilent	8447D	2944A10548	Mar 19, 2010	Sep 19, 2010
3.	Bi-log Antenna	TESEQ	CBL6112D	23192	Dec 01, 2009	Dec 01, 2010
4.	Spectrum Analyzer	Agilent	E7405A	MY45106600	May 19, 2010	May 19, 2011
5.	Software	Audix	E3	SET00200 9912M295-2	--	--

4.2 Block Diagram of Test Setup

4.2.1 EUT and Peripherals

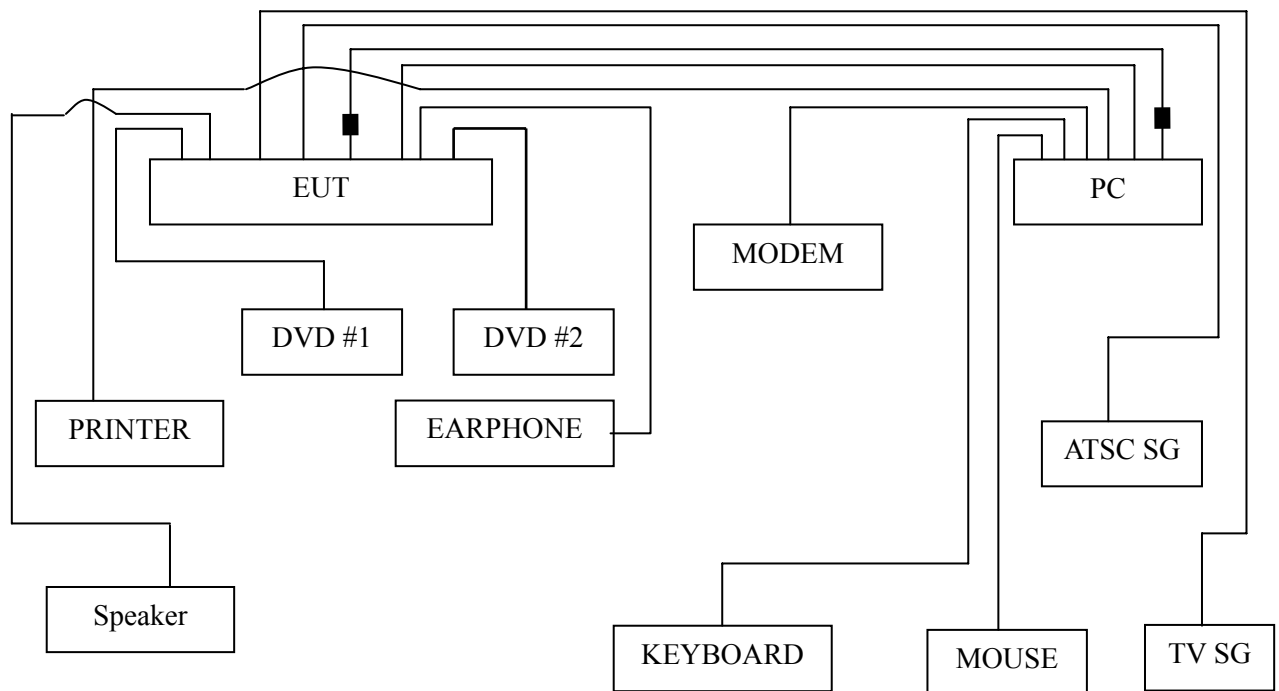

■ : Ferrite core

4.2.2 Radiated emission test setup

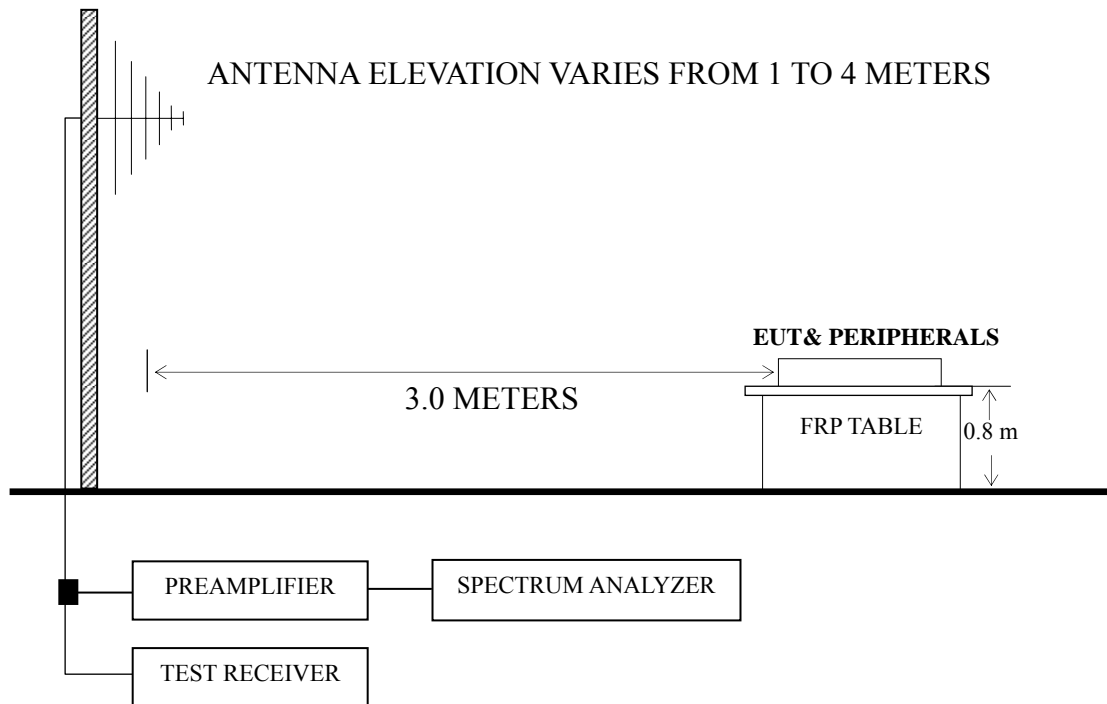

■ : 50 ohm Coaxial Switch

4.3 Radiated Emission Limit [FCC Part 15 Subpart B 15.109(a)]

Frequency (MHz)	Distance (m)	Field strength limits	
		($\mu\text{V/m}$)	dB ($\mu\text{V/m}$)
30 ~ 88	3	100	40.0
88 ~ 216	3	150	43.5
216 ~ 960	3	200	46.0
Above 960	3	500	54.0

NOTE 1 - Emission Level dB ($\mu\text{V/m}$) = 20 log Emission Level ($\mu\text{V/m}$)

NOTE 2 - The tighter limit applies at the band edges.

NOTE 3 - Distance refers to the distance in meters between the measuring instrument antenna and the closed point of any part of the device or system.

NOTE 4 - The limits shown are based on Quasi-peak value detector.

4.4 Test Configuration

The configuration of the EUT and peripherals are same as those used in conducted emission test.

Please refer to Sec.3.4.

4.5 Operating Condition of EUT

Same as conducted emission test which is listed in Sec.3.5, except for the test setup replaced by Sec.4.2.

4.6 Test Procedures

The EUT and peripherals were placed on a FRP turntable that is 0.8 meter above ground. The FRP turntable rotated 360 degrees to determine the position of the maximum emission level. The EUT was set 3 meters away from the receiving antenna, which was mounted on an antenna tower. Broadband antenna (Calibrated Bilog Antenna) was used as receiving antenna. The antenna moved up and down between 1 meter and 4 meters to find out the maximum emission level. Both horizontal and vertical polarizations of the antenna were set on measurement. In order to find the maximum emission, all of the interference cables were manipulated according to ANSI C63.4:2003 requirements during radiated emission test.

The bandwidth of Test Receiver R&S ESVS10 was set at 120 kHz.

The frequency range from 30 MHz to 1000MHz was checked for all test modes.

The test modes were done on radiated disturbance test and all the test results are listed in Sec.4.7.

4.7 Test Results

<PASS>

The frequency and amplitude of the highest radiated emission relative the limit is reported. All the emissions not reported below are too low against the FCC limit.

Test Mode	Data Page
D-Sub 640*480@60Hz	P22
D-Sub 800*600@60Hz	P23
D-Sub 1024*768@60Hz	P24
HDMI 640*480@60Hz	P25
HDMI 800*600@60Hz	P26
HDMI 1024*768@60Hz	P27

NOTE 1 – Emission Level = Antenna Factor + Cable Loss + Meter Reading.

NOTE 2 – The emission levels that are 20dB below the official limit are not reported.

NOTE 3 – 0° was the table front facing the antenna. Degree is calculated from 0° clockwise facing the antenna.

NOTE 4 – The worst case is for D-Sub 1024*768@60Hz test mode. The worst emission at horizontal polarization was detected at 516.00 MHz with corrected signal level of 43.38 dB ($\mu\text{V}/\text{m}$) (limit is 46.00dB ($\mu\text{V}/\text{m}$)), when the antenna was 1.05 m height and the turntable was at 341°. The worst emission at vertical polarization was detected at 113.42 MHz with corrected signal level of 34.51 dB ($\mu\text{V}/\text{m}$) (limit is 43.50 dB ($\mu\text{V}/\text{m}$)), when the antenna was 1.00 m height and the turntable was at 25°.

EUT : LCD TV Temperature : 22°C

Model No. : LCD42V68PCA Humidity : 60%RH

Serial No. : E2010090601 Date of Test : Sep 08, 2010

Test Mode : D-Sub 640*480@60Hz

Polarization	Frequency (MHz)	Meter Reading dB (μ V)	Antenna Factor (dB/m)	Cable Loss (dB)	Emission Level dB (μ V/m)	Limits dB (μ V/m)	Margin (dB)
Horizontal	51.34	17.44	8.61	0.79	26.84	40.00	13.16
	80.44	23.16	7.85	0.95	31.96	40.00	8.04
	148.34	23.43	11.41	1.23	36.07	43.50	7.43
	274.44	19.04	13.43	1.69	34.16	46.00	11.84
	516.94	22.66	18.12	2.29	43.07	46.00	2.93
	638.19	8.78	19.39	2.54	30.71	46.00	15.29
Vertical	114.39	19.32	12.64	1.10	33.06	43.50	10.44
	201.69	20.64	10.78	1.45	32.87	43.50	10.63
	274.44	19.51	13.43	1.69	34.63	46.00	11.37
	366.59	17.35	15.77	1.98	35.10	46.00	10.90
	458.74	15.98	17.35	2.18	35.51	46.00	10.49
	516.94	16.04	18.12	2.29	36.45	46.00	9.55

TEST ENGINEER: RAVEN JIN

EUT : LCD TV Temperature : 22°C

Model No. : LCD42V68PCA Humidity : 60%RH

Serial No. : E2010090601 Date of Test : Sep 08, 2010

Test Mode : D-Sub 800*600@60Hz

Polarization	Frequency (MHz)	Meter Reading dB (μ V)	Antenna Factor (dB/m)	Cable Loss (dB)	Emission Level dB (μ V/m)	Limits dB (μ V/m)	Margin (dB)
Horizontal	53.28	18.01	8.14	0.80	26.95	40.00	13.05
	80.44	23.62	7.85	0.95	32.42	40.00	7.58
	150.28	23.77	11.25	1.24	36.26	43.50	7.24
	274.44	19.27	13.43	1.69	34.39	46.00	11.61
	347.19	16.33	15.24	1.91	33.48	46.00	12.52
	667.29	15.62	19.55	2.61	37.78	46.00	8.22
Vertical	35.82	12.07	16.45	0.68	29.20	40.00	10.80
	114.39	19.41	12.64	1.10	33.15	43.50	10.35
	274.44	18.34	13.43	1.69	33.46	46.00	12.54
	458.74	15.93	17.35	2.18	35.46	46.00	10.54
	518.88	13.82	18.15	2.30	34.27	46.00	11.73
	906.88	9.49	21.76	3.04	34.29	46.00	11.71

TEST ENGINEER: RAVEN JIN

EUT : LCD TV Temperature : 22°C

Model No. : LCD42V68PCA Humidity : 60%RH

Serial No. : E2010090601 Date of Test : Sep 08, 2010

Test Mode : D-Sub 1024*768@60Hz

Polarization	Frequency (MHz)	Meter Reading dB (μV)	Antenna Factor (dB/m)	Cable Loss (dB)	Emission Level dB (μV/m)	Limits dB (μV/m)	Margin (dB)
Horizontal	53.28	20.36	8.14	0.80	29.30	40.00	10.70
	80.44	27.03	7.85	0.95	35.83	40.00	4.17
	150.28	23.81	11.25	1.24	36.30	43.50	7.20
	187.14	23.12	10.17	1.40	34.69	43.50	8.81
	274.44	19.46	13.43	1.69	34.58	46.00	11.42
	516.00	23.00	18.09	2.29	43.38	46.00	2.62
Vertical	113.42	20.83	12.58	1.10	34.51	43.50	8.99
	150.28	20.28	11.25	1.24	32.77	43.50	10.73
	274.44	18.74	13.43	1.69	33.86	46.00	12.14
	366.59	17.44	15.77	1.98	35.19	46.00	10.81
	516.94	15.81	18.12	2.29	36.22	46.00	9.78
	909.79	10.64	21.76	3.04	35.44	46.00	10.56

TEST ENGINEER: RAVEN JIN

EUT : LCD TV Temperature : 22°C

Model No. : LCD42V68PCA Humidity : 60%RH

Serial No. : E2010090601 Date of Test : Sep 08, 2010

Test Mode : HDMI 640*480@60Hz

Polarization	Frequency (MHz)	Meter Reading dB (μ V)	Antenna Factor (dB/m)	Cable Loss (dB)	Emission Level dB (μ V/m)	Limits dB (μ V/m)	Margin (dB)
Horizontal	51.34	14.44	8.61	0.79	23.84	40.00	16.16
	80.44	20.16	7.85	0.95	28.96	40.00	11.04
	148.34	20.43	11.41	1.23	33.07	43.50	10.43
	274.44	16.04	13.43	1.69	31.16	46.00	14.84
	516.94	19.66	18.12	2.29	40.07	46.00	5.93
	664.38	9.92	19.54	2.61	32.07	46.00	13.93
Vertical	51.34	50.73	8.61	0.79	32.12	40.00	7.88
	114.39	41.07	12.64	1.10	27.06	43.50	16.44
	274.44	40.39	13.43	1.69	28.63	46.00	17.37
	458.74	39.89	17.35	2.18	31.51	46.00	14.49
	516.94	40.20	18.12	2.29	32.45	46.00	13.55
	911.73	34.61	21.78	3.04	31.99	46.00	14.01

TEST ENGINEER: RAVEN JIN

EUT : LCD TV Temperature : 22°C

Model No. : LCD42V68PCA Humidity : 60%RH

Serial No. : E2010090601 Date of Test : Sep 08, 2010

Test Mode : HDMI 800*600@60Hz

Polarization	Frequency (MHz)	Meter Reading dB (μV)	Antenna Factor (dB/m)	Cable Loss (dB)	Emission Level dB (μV/m)	Limits dB (μV/m)	Margin (dB)
Horizontal	80.44	19.62	7.85	0.95	28.42	40.00	11.58
	150.28	19.77	11.25	1.24	32.26	43.50	11.24
	274.44	15.27	13.43	1.69	30.39	46.00	15.61
	434.49	10.77	16.97	2.13	29.87	46.00	16.13
	516.94	20.31	18.12	2.29	40.72	46.00	5.28
	667.29	11.62	19.55	2.61	33.78	46.00	12.22
Vertical	51.34	25.06	8.61	0.79	34.46	40.00	5.54
	114.39	15.41	12.64	1.10	29.15	43.50	14.35
	274.44	14.34	13.43	1.69	29.46	46.00	16.54
	458.74	11.93	17.35	2.18	31.46	46.00	14.54
	518.88	9.82	18.15	2.30	30.27	46.00	15.73
	987.39	4.35	22.32	4.25	30.92	54.00	23.08

TEST ENGINEER: RAVEN JIN

EUT : LCD TV Temperature : 22°C

Model No. : LCD42V68PCA Humidity : 60%RH

Serial No. : E2010090601 Date of Test : Sep 08, 2010

Test Mode : HDMI 1024*768@60Hz

Polarization	Frequency (MHz)	Meter Reading dB (μV)	Antenna Factor (dB/m)	Cable Loss (dB)	Emission Level dB (μV/m)	Limits dB (μV/m)	Margin (dB)
Horizontal	80.44	22.03	7.85	0.95	30.83	40.00	9.17
	113.42	16.85	12.58	1.10	30.53	43.50	12.97
	150.28	18.81	11.25	1.24	31.30	43.50	12.20
	187.14	18.12	10.17	1.40	29.69	43.50	13.81
	274.44	14.46	13.43	1.69	29.58	46.00	16.42
	516.94	20.73	18.12	2.29	41.14	46.00	4.86
Vertical	51.34	25.17	8.61	0.79	34.57	40.00	5.43
	113.42	14.83	12.58	1.10	28.51	43.50	14.99
	216.24	14.40	11.43	1.50	27.33	46.00	18.67
	366.59	11.44	15.77	1.98	29.19	46.00	16.81
	516.94	9.81	18.12	2.29	30.22	46.00	15.78
	977.69	8.24	22.27	4.01	34.52	54.00	19.48

TEST ENGINEER: RAVEN JIN

5 DEVIATION TO TEST SPECIFICATIONS

None.

6 DEBUG DESCRIPTION

The following components are used during the countermeasure procedures:

Name	M/N	Manufacturer	Location
Ferrite core	ZCAT1519-0830\ROH	FEELUX	See Internal Photos Figure 19, 20
		Rui Feng Electronic Co., Ltd.	
		Hai An Magnetic Material No.2 Factory	
		JIANGSU LETTALL ELECTRONICS CO., LTD.	
Ferrite core	ZCAT3035-1330\ROH	FEELUX	See Internal Photos Figure 18
		Rui Feng Electronic Co., Ltd.	
		Hai An Magnetic Material No.2 Factory	
		JIANGSU LETTALL ELECTRONICS CO., LTD.	

Note: We had required the applicant and manufacturer that all electrical and mechanical devices employed for spurious radiation suppression, including any modifications made during certification testing, must be incorporated in each unit marked

TEST ENGINEER:

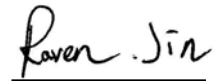

(RAVEN JIN)