

Application for FCC Certificate
On Behalf of
Hisense Electric Co., Ltd.

LCD TV

Model No.	Serial No.	Brand
LTDN42T18GUS	E2010050701	Hisense
42LED55SA	--	PROSCAN
LED42A55RS	--	RCA

FCC ID : W9HLCDCCE0002

Prepared For : Hisense Electric Co., Ltd.
No.218 Qianwangang Road, Economy & Technology
Development Zone, Qingdao, China

Prepared By : Audix Technology (Shanghai) Co., Ltd.
3F 34Bldg 680 Guiping Rd,
Caohejing Hi-Tech Park,
Shanghai 200233, China

Tel: +86-21-64955500
Fax: +86-21-64955491

Report No. : ACI-F09126A2
Date of Test : May 17-19, 2010
Date of Report : May 19, 2010

TABLE OF CONTENTS

	Page
1 SUMMARY OF STANDARDS AND RESULTS.....	4
1.1 Description of Standards and Results.....	4
2 GENERAL INFORMATION.....	5
2.1 Description of Equipment Under Test.....	5
2.2 Peripherals.....	6
2.3 Description of Test Facility.....	8
2.4 Measurement Uncertainty.....	8
3 CONDUCTED EMISSION TEST.....	9
3.2 Block Diagram of Test Setup.....	9
3.3 Conducted Emission Limit [FCC Part 15 Subpart B 15.107(a)].....	10
3.4 Test Configuration.....	10
3.5 Operating Condition of EUT.....	11
3.6 Test Procedures.....	11
3.7 Test Results.....	12
4 RADIATED EMISSION TEST.....	19
4.1 Test Equipment.....	19
4.2 Block Diagram of Test Setup.....	19
4.3 Radiated Emission Limit [FCC Part 15 Subpart B 15.109(a)].....	20
4.4 Test Configuration.....	20
4.5 Operating Condition of EUT.....	20
4.6 Test Procedures.....	21
4.7 Test Results.....	21
5 DEVIATION TO TEST SPECIFICATIONS.....	28
6 DEBUG DESCRIPTION.....	29

TEST REPORT FOR FCC CERTIFICATE

Applicant : Hisense Electric Co., Ltd.
 Manufacturer : Hisense Electric Co., Ltd.
 EUT Description : LCD TV

Model No.	Serial No.	Brand	Power Supply
LTDN42T18GUS	E2010050701	Hisense	120V/60Hz
42LED55SA	--	PROSCAN	
LED42A55RS	--	RCA	

Test Procedure Used:

*FCC RULES AND REGULATIONS PART 15 SUBPART B CLASS B OCTOBER 2009
AND ANSI C63.4-2003*

The device described above is tested by Audix Technology (Shanghai) Co., Ltd. to determine the maximum emission levels emanating from the device. The maximum emission levels are compared to the FCC Part 15 Subpart B (Class B) limits both radiated and conducted emissions.

The test results are contained in this test report and Audix Technology (Shanghai) Co., Ltd. is assumed full responsibility for the accuracy and completeness of these measurements. This report shows that the EUT (M/N: Refer to Sec.2.1; S/N: Refer to Sec.2.1) which was tested in 3m anechoic chamber May 17-19, 2010 is technically compliance with the FCC official limits also.

This report applies to above tested sample only. This report shall not be reproduced in part without written approval of Audix Technology (Shanghai) Co., Ltd.

This report contains data that are not covered by the NVLAP accreditation.

This report must not be used by the client to claim product certification, approval, or endorsement by NVLAP, NIST, or any agency of the federal government.

The test results for EUT's TV functions are contained in No.F09125A2, a Verification report.

Date of Test : May 17-19, 2010 Date of Report : May 19, 2010

Producer : Candy xi
CANDY XI / Assistant

Review : Dio Yang
DIO YANG / Deputy Assistant Manager

AUDIX[®] For and on behalf of
Audix Technology (Shanghai) Co., Ltd.

Signatory : Byron Kwo
Authorized Signature EMC BYRON KWO / Manager

1 SUMMARY OF STANDARDS AND RESULTS

1.1 Description of Standards and Results

The EUT have been tested according to the applicable standards as referenced below:

Description of Test Item	Standard	Limits	Results
EMISSION			
Conducted Disturbance at the Mains Terminal	FCC RULES AND REGULATIONS PART 15 SUBPART B OCTOBER 2009 AND ANSI C63.4-2003	15.107(a) Class B	Pass
Radiated Disturbance	FCC RULES AND REGULATIONS PART 15 SUBPART B OCTOBER 2009 AND ANSI C63.4-2003	15.109(a) Class B	Pass

2 GENERAL INFORMATION

2.1 Description of Equipment Under Test

Description : LCD TV

Type of EUT : Production Pre-product Pro-type

Model No.	Serial No.	Brand
LTDN42T18GUS	E2010050701	Hisense
42LED55SA	--	PROSCAN
LED42A55RS	--	RCA

Note 1 : The difference list for all models are as follows:

Report No.	Model No.	Rev. Summary	Edition No.	Data of Rev.
ACI-F09126	LTDN42T18GUS, 42LED55SA	Original Report.	0	Dec 18, 2009
ACI-F09126A1	LTDN42T18GUS, 42LED55SA, LED42A55RS	To add one model number.	Rev. A1	Jan 19, 2010
ACI-F09126A2	LTDN42T18GUS, 42LED55SA, LED42A55RS	To add one LCD Panel	Rev. A2	May 19, 2010

Note 2 : The above models are all the same except for the different model number and brand.

Note 3 : The LTDN42T18GUS was tested and recorded in this report.

Applicant : Hisense Electric Co., Ltd.
No.218 Qianwangang Road, Economy &
Technology Development Zone, Qingdao, China

Manufacturer : Hisense Electric Co., Ltd.
No.218 Qianwangang Road, Economy &
Technology Development Zone, Qingdao, China

LCD Panel : Manufacturer: LG Display
M/N : LC420EUD (SC) (A1)

Max Resolution: 1024*768@60Hz

D-Sub Cable : Shielded, Detachable, 1.85m, with two cores on cable

HDMI Cable : Shielded, Detachable, 1.85m, without core on cable

Power Cord : Unshielded, Detachable, 1.80m

Remark:

The EUT is a LCD TV which input/output ports as follows:

Bottom Port:

- | | | |
|-----|------------------------------------|-------------------------|
| (1) | One Component of YPbPr2 Port | Connected with DVD2 |
| (2) | One Component of YPbPr2 Audio Port | Connected with DVD2 |
| (3) | One Earphone Port | Connected with Earphone |
| (4) | One HDMI4 Port | Connected with DVD3 |
| (5) | One COAXIAL Port | Connected with DVD3 |
| (6) | One Service Port | Do not open to Customer |

Side Port

- | | | |
|-----|------------------------------------|------------------------------|
| (1) | One Component of YPbPr1 Port | Connected with DVD1 |
| (2) | One Component of YPbPr1 Audio Port | Connected with DVD1 |
| (3) | One HDMI1 Port | Connected with DVD1 |
| (4) | One HDMI2 Port | Connected with DVD2 |
| (5) | One HDMI3 Port | Connected with PC |
| (6) | One VGA Port | Connected with PC |
| (7) | One VGA AUDIO Port | Connected with PC |
| (8) | One ANT Port | Connected with ATSC SG/TV SG |
| (9) | One Component of Audio Out Port | Connected with Speaker |

2.2 Peripherals

2.2.1 PC

Manufacturer : HP
 Model Number : dx7400MT
 Serial Number : CNG8130K89
 Power Cord : Unshielded, Detachable, 1.8m
 Certificate : FCC DoC; CE/EMC; VCCI; C-Tick; UL
 BSMI (R33001) 3C (A000111)
 MIC (E-A011-04-2659(B))

2.2.2 Printer

Manufacturer : HP
 Model Number : C3990A
 Serial Number : JPZX020487
 Data Cable : Shielded, detachable, 1.5m
 Certificate : GS, CE/EMC, C-Tick, FCC DoC

2.2.3 Keyboard

Manufacturer : Microsoft
Model Number : RT2300
Serial Number : 7668200662248
Data Cable : Shielded, undetachable ,1.8m
Certificate : CE/EMC, FCC DoC, VCCI, MIC, C-Tick,
BSMI

2.2.4 Mouse

Manufacturer : Microsoft
Model Number : RT2300
Serial Number : 6965712071551
Data Cable : Shielded, undetachable, 1.8m.
Certificate : CE/EMC, FCC DoC, VCCI, MIC, C-Tick,
BSMI

2.2.5 Modem

Manufacturer : TP-LINK
Model Number : TM-EC5658V
Serial Number : 07123301053
Data Cable : Shielded, Detachable, 1.8m
Certificate : FCC DoC, CE/EMC, CCC

2.2.6 Earphone

Manufacturer : SONY
Model Number : MDR-E808
Serial Number : 1808030805305506

2.2.7 TV Signal Generator

Manufacturer : FLUKE
Model Number : 54200m01
Serial Number : 814008
Data Cable : Shielded, detachable, 2.0m
Power Cord : Unshielded, detachable, 2.0m
Certificate : CE/EMC, FCC DoC, CCC

2.2.8 ATSC Signal Generator

Manufacturer : SENCORE
Model Number : ATSC997
Serial Number : 6790071

2.2.9 DVD#1

Manufacturer : PHILIPS
Model Number : DVP3986K/93
Serial Number : KX1A0902120108
Certificate : FCC DoC, CE/EMC, CCC

2.2.10 DVD#2

Manufacturer : DGT RONIK
Model Number : DV-A340
Serial Number : KX1A0902120082
Certificate : FCC DoC, CE/EMC, CCC

2.2.11 DVD#3

Manufacturer : LG
Model Number : DF9921N
Serial Number : 3850R-N846W
Certificate : FCC DoC, CE/EMC, CCC

2.2.12 Speaker

Manufacturer : DIBA
Model Number : T520
Serial Number : 10628

2.3 Description of Test Facility

Site Description (Semi-Anechoic Chamber) : Sept. 17, 1998 file on
Apr 29, 2009 Renewed
Federal Communications Commission
FCC Engineering Laboratory
7435 Oakland Mills Road
Columbia, MD 21046, USA

Name of Firm : Audix Technology (Shanghai) Co., Ltd.

Site Location : 3F 34Bldg 680 Guiping Rd,
Caohejing Hi-Tech Park,
Shanghai 200233, China

NVLAP Lab Code : 200371-0

2.4 Measurement Uncertainty

Conducted Emission Expanded Uncertainty: U = 1.26 dB
Radiated Emission Expanded Uncertainty : U = 3.02 dB

3 CONDUCTED EMISSION TEST

3.1.1 Test Equipment

The following test equipments are used during the conducted emission test in a shielded room:

Item	Type	Manufacturer	Model No.	Serial No.	Last Cal.	Next Cal.
1.	Test Receiver	R&S	ESCI	100841	Oct 15, 2009	Oct 15, 2010
2.	Artificial Mains Network (AMN)	R&S	ESH2-Z5	843890/011	Apr 02, 2010	Apr 02, 2011
3.	Line Impedance Stabilization Network (LISN)	Kyoritsu	KNW-407	8-1280-4	Apr 02, 2010	Apr 02, 2011
4.	50 Ω Coaxial Switch	Anritsu	MP59B	6200426389	Mar 19, 2010	Sep 19, 2010
5.	50 Ω Terminator	Anritsu	BNC	001	Apr 02, 2010	Apr 02, 2011
6.	Software	Audix	E3	SET00200 9804M592	--	--

3.2 Block Diagram of Test Setup

3.2.1 EUT & Peripherals

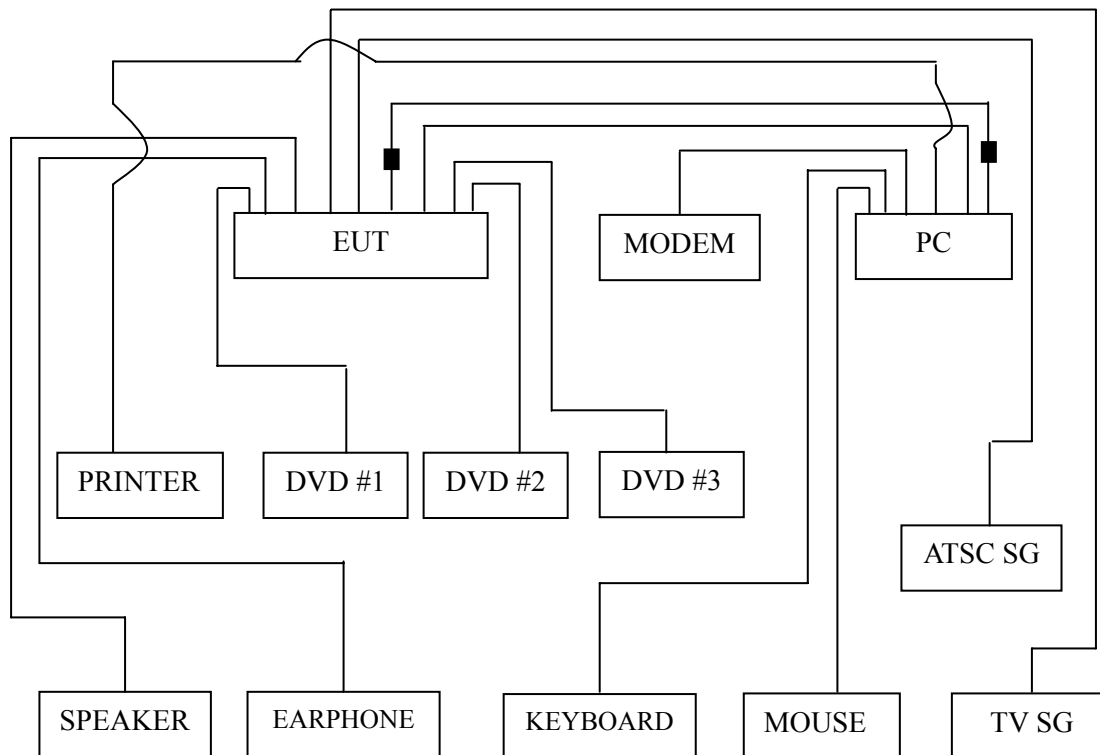

■ : Ferrite core

3.2.2 Conducted Disturbance Test Setup

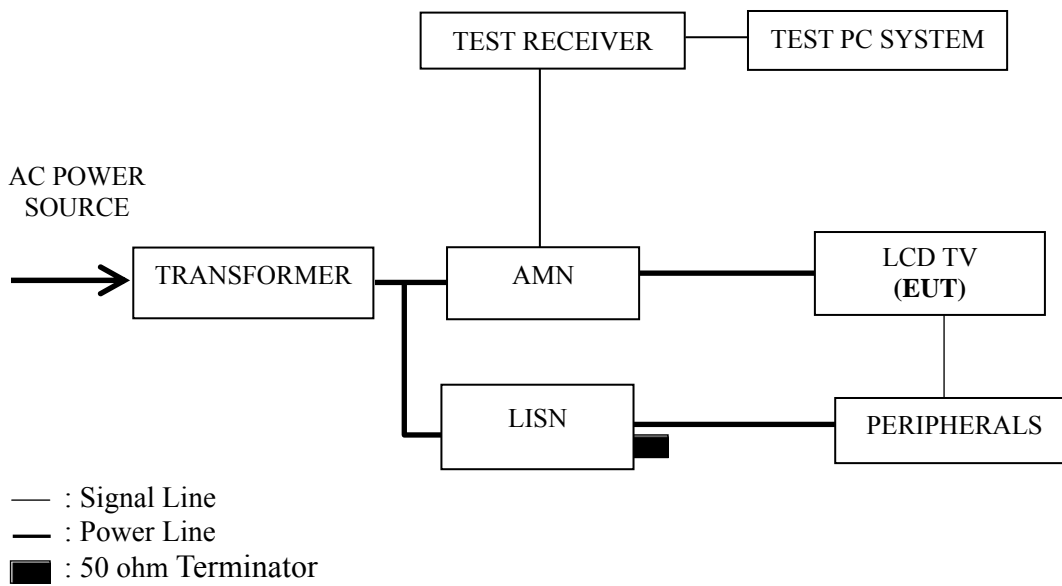

3.3 Conducted Emission Limit [FCC Part 15 Subpart B 15.107(a)]

Frequency Range (MHz)	Limits dB (μ V)	
	Quasi-peak	Average
0.15 ~ 0.5	66~56	56~46
0.5 ~ 5	56	46
5 ~ 30	60	50

NOTE 1 – The lower limit shall apply at the transition frequencies.
 NOTE 2 – The limit decreases linearly with the logarithm of the frequency in the range 0.15 MHz~0.50 MHz

3.4 Test Configuration

The EUT (listed in Sec.2.1) and the peripherals (listed in Sec 2.2) were installed as shown on Sec.3.2 to meet FCC requirement and operating in a manner that tends to maximize its emission level in a normal application.

3.5 Operating Condition of EUT

3.5.1 Setup the EUT and peripherals as shown in Sec. 3.2.

3.5.2 Turn on the power of all equipments and the EUT.

3.5.3 Set the contrast & brightness of EUT to maximum.

3.5.4 PC system ran the self-test program “EMC Test” by windows XP and sent “H” characters to EUT through graphic card, the EUT’s screen displayed and filled with “H” pattern by its resolution (Via D-Sub & HDMI Input).

3.5.5 Repeat above procedure from 3.5.3 to 3.5.4 for difference test mode.

3.5.6 The other peripherals devices were driven and operated during the test.

3.5.7 The test modes are as follows:

Test Mode
D-Sub 640*480@60Hz
D-Sub 800*600@60Hz
D-Sub 1024*768@60Hz
HDMI 640*480@60Hz
HDMI 800*600@60Hz
HDMI 1024*768@60Hz

3.6 Test Procedures

The EUT and peripherals were connected to the power mains through an Artificial Mains Network (AMN). This provided a 50 ohm coupling impedance for the measuring equipment.

Both sides of AC line (Line & Neutral) were checked for maximum conducted interference. In order to find the maximum emission, the relative positions of equipment and all of the interface cables were changed or manipulated according to ANSI C63.4:2003 during conducted emission test.

The bandwidth of R&S Test Receiver ESCI was set at 9 kHz.

The frequency range from 150 kHz to 30 MHz was checked.

The test modes were done on conducted disturbance test and all the test results are listed in Sec. 3.7.

3.7 Test Results

< **PASS** >

The frequency and amplitude of the highest conducted emission relative to the limit is reported. All emissions not reported below are too low against the prescribed limits.

Test Mode	Data Page
D-Sub 640*480@60Hz	P13
D-Sub 800*600@60Hz	P14
D-Sub 1024*768@60Hz	P15
HDMI 640*480@60Hz	P16
HDMI 800*600@60Hz	P17
HDMI 1024*768@60Hz	P18

NOTE 1 – Factor = Cable Loss + AMN Factor.

NOTE 2 – Emission Level = Meter Reading + Factor.

NOTE 3 – “QP” means “Quasi-Peak” values, “AV” means “Average” values.

NOTE 4 – The worst case is for HDMI 1024*768@60Hz test mode. The worst emission is detected at 8.637 MHz (Quasi-Peak Value) with corrected signal level of 49.62 dB (μ V) (limit is 60.00 dB (μ V)), when the Neutral of the EUT is connected to AMN.

EUT : LCD TV Temperature : 22°C

Model No. : LTDN42T18GUS Humidity : 48%RH

Serial No. : E2010050701 Date of Test : May 17, 2010

Test Mode : D-Sub 640*480@60Hz

Test Line	Frequency (MHz)	Meter Reading dB(μ V)	Factor (dB)	Emission Level dB(μ V)	Limits dB(μ V)	Margin (dB)	Remark
Line	0.160	41.16	0.27	41.43	65.47	24.04	QP
	0.484	25.70	0.47	26.17	56.27	30.10	
	0.813	31.38	0.48	31.86	56.00	24.14	
	4.926	31.52	0.64	32.16	56.00	23.84	
	8.412	47.34	0.72	48.06	60.00	11.94	
	18.820	37.31	1.10	38.41	60.00	21.59	AV
	0.160	28.71	0.27	28.98	55.47	26.49	
	0.484	14.68	0.47	15.15	46.27	31.12	
	0.813	15.86	0.48	16.34	46.00	29.66	
	4.926	19.93	0.64	20.57	46.00	25.43	
8.412	36.00	0.72	36.72	50.00	13.28	AV	
18.820	30.61	1.10	31.71	50.00	18.29		
Neutral	0.160	41.04	0.24	41.28	65.47	24.19	QP
	0.481	26.64	0.44	27.08	56.32	29.24	
	0.899	31.09	0.48	31.57	56.00	24.43	
	4.926	31.56	0.65	32.21	56.00	23.79	
	8.637	46.44	0.74	47.18	60.00	12.82	
	19.224	41.06	1.08	42.14	60.00	17.86	AV
	0.160	28.97	0.24	29.21	55.47	26.26	
	0.481	15.81	0.44	16.25	46.32	30.07	
	0.899	16.48	0.48	16.96	46.00	29.04	
	4.926	17.37	0.65	18.02	46.00	27.98	
8.637	34.15	0.74	34.89	50.00	15.11	AV	
19.224	31.86	1.08	32.94	50.00	17.06		

TEST ENGINEER: TED ZHU

EUT : LCD TV Temperature : 22°C

Model No. : LTDN42T18GUS Humidity : 48%RH

Serial No. : E2010050701 Date of Test : May 17, 2010

Test Mode : D-Sub 800*600@60Hz

Test Line	Frequency (MHz)	Meter Reading dB(μ V)	Factor (dB)	Emission Level dB(μ V)	Limits dB(μ V)	Margin (dB)	Remark
Line	0.160	41.14	0.27	41.41	65.47	24.06	QP
	0.481	25.47	0.47	25.94	56.32	30.38	
	0.914	31.15	0.49	31.64	56.00	24.36	
	4.926	32.36	0.64	33.00	56.00	23.00	
	8.062	44.34	0.71	45.05	60.00	14.95	
	19.740	39.17	1.13	40.30	60.00	19.70	
	0.160	28.01	0.27	28.28	55.47	27.19	AV
	0.481	14.87	0.47	15.34	46.32	30.98	
	0.914	14.83	0.49	15.32	46.00	30.68	
	4.926	18.16	0.64	18.80	46.00	27.20	
8.062	32.21	0.71	32.92	50.00	17.08		
19.740	31.12	1.13	32.25	50.00	17.75		
Neutral	0.160	41.19	0.24	41.43	65.47	24.04	QP
	0.484	26.60	0.44	27.04	56.27	29.23	
	1.210	28.62	0.50	29.12	56.00	26.88	
	4.926	33.64	0.65	34.29	56.00	21.71	
	8.412	48.14	0.73	48.87	60.00	11.13	
	19.326	40.97	1.08	42.05	60.00	17.95	AV
	0.160	28.85	0.24	29.09	55.47	26.38	
	0.484	15.60	0.44	16.04	46.27	30.23	
	1.210	11.59	0.50	12.09	46.00	33.91	
	4.926	18.03	0.65	18.68	46.00	27.32	
8.412	33.48	0.73	34.21	50.00	15.79		
19.326	32.57	1.08	33.65	50.00	16.35		

TEST ENGINEER: TED ZHU

EUT : LCD TV Temperature : 22°C

Model No. : LTDN42T18GUS Humidity : 48%RH

Serial No. : E2010050701 Date of Test : May 17, 2010

Test Mode : D-Sub 1024*768@60Hz

Test Line	Frequency (MHz)	Meter Reading dB(μ V)	Factor (dB)	Emission Level dB(μ V)	Limits dB(μ V)	Margin (dB)	Remark
Line	0.160	41.00	0.27	41.27	65.47	24.20	QP
	0.481	25.84	0.47	26.31	56.32	30.01	
	0.909	31.98	0.48	32.46	56.00	23.54	
	4.926	32.45	0.64	33.09	56.00	22.91	
	8.412	46.15	0.72	46.87	60.00	13.13	
	19.326	39.76	1.11	40.87	60.00	19.13	
	0.160	33.37	0.27	33.64	55.47	21.83	AV
	0.481	14.14	0.47	14.61	46.32	31.71	
	0.909	13.06	0.48	13.54	46.00	32.46	
	4.926	16.01	0.64	16.65	46.00	29.35	
	8.412	33.34	0.72	34.06	50.00	15.94	
	19.326	31.51	1.11	32.62	50.00	17.38	
Neutral	0.160	40.84	0.24	41.08	65.47	24.39	QP
	0.481	27.01	0.44	27.45	56.32	28.87	
	0.899	31.42	0.48	31.90	56.00	24.10	
	4.202	28.82	0.63	29.45	56.00	26.55	
	8.323	48.67	0.73	49.40	60.00	10.60	
	19.326	41.03	1.08	42.11	60.00	17.89	
	0.160	31.49	0.24	31.73	55.47	23.74	AV
	0.481	16.13	0.44	16.57	46.32	29.75	
	0.899	18.47	0.48	18.95	46.00	27.05	
	4.202	17.18	0.63	17.81	46.00	28.19	
	8.323	34.49	0.73	35.22	50.00	14.78	
	19.326	33.38	1.08	34.46	50.00	15.54	

TEST ENGINEER: TED ZHU

EUT : LCD TV Temperature : 22°C

Model No. : LTDN42T18GUS Humidity : 48%RH

Serial No. : E2010050701 Date of Test : May 17, 2010

Test Mode : HDMI 640*480@60Hz

Test Line	Frequency (MHz)	Meter Reading dB(μ V)	Factor (dB)	Emission Level dB(μ V)	Limits dB(μ V)	Margin (dB)	Remark
Line	0.160	41.19	0.27	41.46	65.47	24.01	QP
	0.481	25.93	0.47	26.40	56.32	29.92	
	0.909	32.80	0.48	33.28	56.00	22.72	
	4.822	29.97	0.64	30.61	56.00	25.39	
	8.729	44.11	0.72	44.83	60.00	15.17	
	19.326	40.30	1.11	41.41	60.00	18.59	
	0.160	29.46	0.27	29.73	55.47	25.74	AV
	0.481	13.56	0.47	14.03	46.32	32.29	
	0.909	14.74	0.48	15.22	46.00	30.78	
	4.822	17.01	0.64	17.65	46.00	28.35	
	8.729	31.55	0.72	32.27	50.00	17.73	
	19.326	31.16	1.11	32.27	50.00	17.73	
Neutral	0.160	41.03	0.24	41.27	65.47	24.20	QP
	0.481	26.89	0.44	27.33	56.32	28.99	
	0.899	32.03	0.48	32.51	56.00	23.49	
	4.622	30.84	0.64	31.48	56.00	24.52	
	8.592	45.03	0.74	45.77	60.00	14.23	
	19.326	40.24	1.08	41.32	60.00	18.68	
	0.160	29.43	0.24	29.67	55.47	25.80	AV
	0.481	15.75	0.44	16.19	46.32	30.13	
	0.899	18.79	0.48	19.27	46.00	26.73	
	4.622	16.29	0.64	16.93	46.00	29.07	
	8.592	34.09	0.74	34.83	50.00	15.17	
	19.326	31.84	1.08	32.92	50.00	17.08	

TEST ENGINEER: TED ZHU

EUT : LCD TV Temperature : 22°C

Model No. : LTDN42T18GUS Humidity : 48%RH

Serial No. : E2010050701 Date of Test : May 17, 2010

Test Mode : HDMI 800*600@60Hz

Test Line	Frequency (MHz)	Meter Reading dB(μ V)	Factor (dB)	Emission Level dB(μ V)	Limits dB(μ V)	Margin (dB)	Remark
Line	0.160	41.28	0.27	41.55	65.47	23.92	QP
	0.484	25.80	0.47	26.27	56.27	30.00	
	0.914	30.98	0.49	31.47	56.00	24.53	
	4.822	30.30	0.64	30.94	56.00	25.06	
	8.637	48.33	0.72	49.05	60.00	10.95	
	19.326	39.18	1.11	40.29	60.00	19.71	
	0.160	33.14	0.27	33.41	55.47	22.06	AV
	0.484	15.42	0.47	15.89	46.27	30.38	
	0.914	15.59	0.49	16.08	46.00	29.92	
	4.822	18.46	0.64	19.10	46.00	26.90	
	8.637	32.90	0.72	33.62	50.00	16.38	
	19.326	30.63	1.11	31.74	50.00	18.26	
Neutral	0.160	41.05	0.24	41.29	65.47	24.18	QP
	0.484	26.74	0.44	27.18	56.27	29.09	
	0.899	32.01	0.48	32.49	56.00	23.51	
	4.622	34.69	0.64	35.33	56.00	20.67	
	8.729	48.84	0.74	49.58	60.00	10.42	
	19.326	42.98	1.08	44.06	60.00	15.94	
	0.160	32.51	0.24	32.75	55.47	22.72	AV
	0.484	16.53	0.44	16.97	46.27	29.30	
	0.899	19.91	0.48	20.39	46.00	25.61	
	4.622	17.64	0.64	18.28	46.00	27.72	
	8.729	32.87	0.74	33.61	50.00	16.39	
	19.326	32.48	1.08	33.56	50.00	16.44	

TEST ENGINEER: TED ZHU

EUT : LCD TV Temperature : 22°C

Model No. : LTDN42T18GUS Humidity : 48%RH

Serial No. : E2010050701 Date of Test : May 17, 2010

Test Mode : HDMI 1024*768@60Hz

Test Line	Frequency (MHz)	Meter Reading dB(μ V)	Factor (dB)	Emission Level dB(μ V)	Limits dB(μ V)	Margin (dB)	Remark
Line	0.160	40.95	0.27	41.22	65.47	24.25	QP
	0.489	26.00	0.48	26.48	56.19	29.71	
	0.909	32.50	0.48	32.98	56.00	23.02	
	4.622	27.85	0.63	28.48	56.00	27.52	
	8.501	47.44	0.72	48.16	60.00	11.84	
	19.021	40.49	1.10	41.59	60.00	18.41	AV
	0.160	31.85	0.27	32.12	55.47	23.35	
	0.489	13.79	0.48	14.27	46.19	31.92	
	0.909	15.21	0.48	15.69	46.00	30.31	
	4.622	16.15	0.63	16.78	46.00	29.22	
8.501	33.57	0.72	34.29	50.00	15.71	QP	
19.021	32.26	1.10	33.36	50.00	16.64		
0.161	41.00	0.24	41.24	65.43	24.19		
0.481	29.19	0.44	29.63	56.32	26.69		
0.880	31.39	0.48	31.87	56.00	24.13		
Neutral	4.822	33.16	0.65	33.81	56.00	22.19	QP
	8.637	48.88	0.74	49.62	60.00	10.38	
	19.224	42.76	1.08	43.84	60.00	16.16	
	0.161	32.02	0.24	32.26	55.43	23.17	
	0.481	16.65	0.44	17.09	46.32	29.23	
	0.880	17.39	0.48	17.87	46.00	28.13	
	4.822	19.99	0.65	20.64	46.00	25.36	
	8.637	33.01	0.74	33.75	50.00	16.25	
	19.224	31.73	1.08	32.81	50.00	17.19	

TEST ENGINEER: TED ZHU

4 RADIATED EMISSION TEST

4.1 Test Equipment

The following test equipments are used during the radiated emission test in a semi-anechoic chamber:

Item	Type	Manufacturer	Model No.	Serial No.	Last Cal.	Next Cal.
1.	Test Receiver	R&S	ESVS10	844594/001	Mar 07, 2010	Mar 07, 2011
2.	Preamplifier	Agilent	8447D	2944A10548	Mar 19, 2010	Sep 19, 2010
3.	Bi-log Antenna	TESEQ	CBL6112D	23193	May 14, 2009	May 14, 2011
4.	Spectrum	Agilent	E7405A	MY45106600	May 19, 2010	May 19, 2011
5.	Software	Audix	E3	SET00200 9912M295-2	--	--

4.2 Block Diagram of Test Setup

4.2.1 EUT and Peripherals

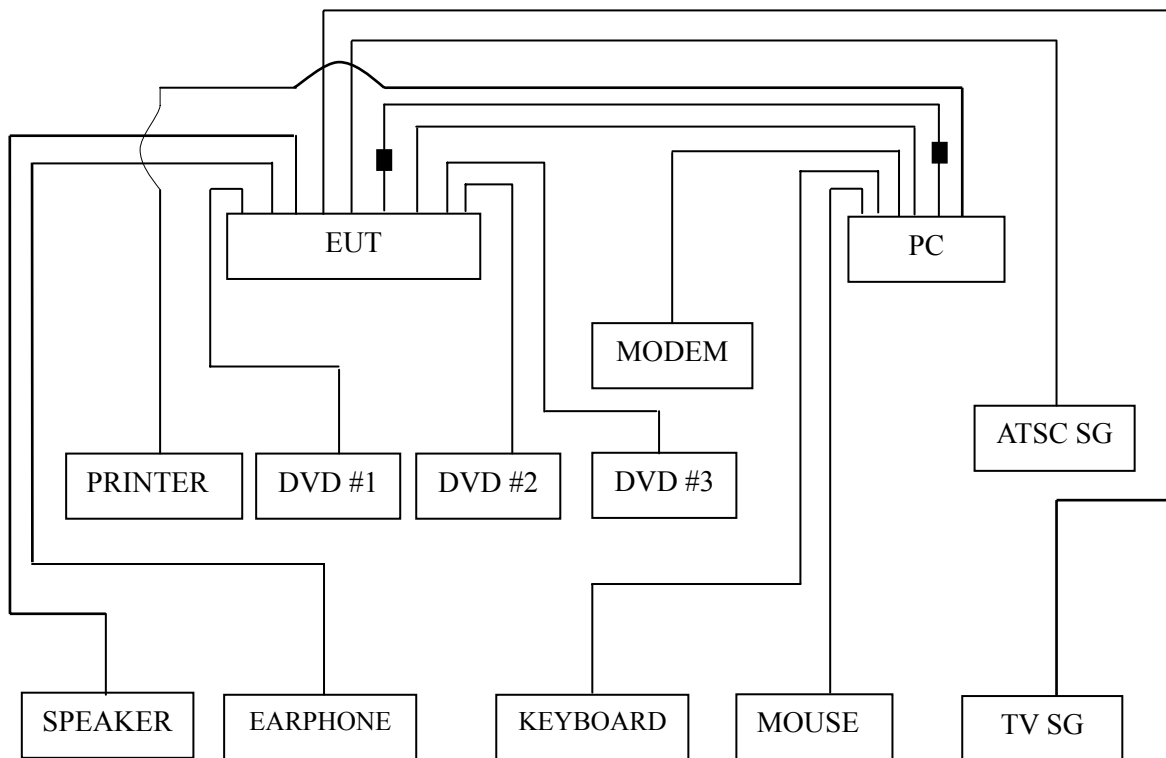

■ : Ferrite core

4.2.2 Radiated emission test setup

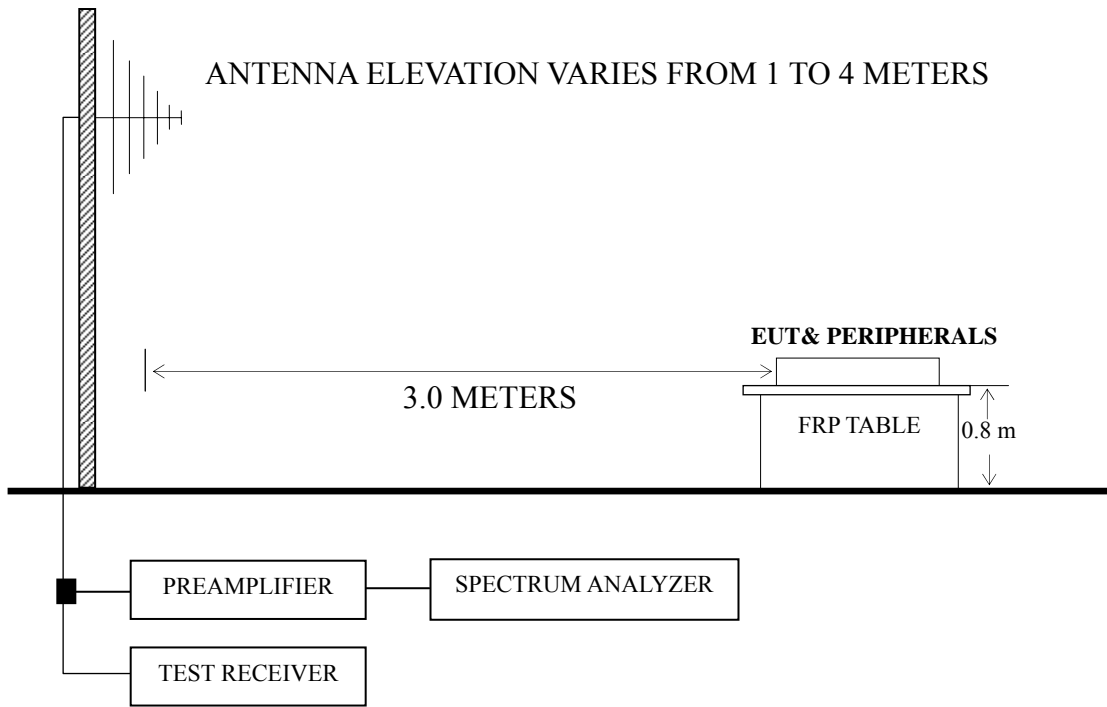

■ : 50 ohm Coaxial Switch

4.3 Radiated Emission Limit [FCC Part 15 Subpart B 15.109(a)]

Frequency (MHz)	Distance (m)	Field strength limits	
		($\mu\text{V/m}$)	dB ($\mu\text{V/m}$)
30 ~ 88	3	100	40.0
88 ~ 216	3	150	43.5
216 ~ 960	3	200	46.0
Above 960	3	500	54.0

NOTE 1 - Emission Level dB ($\mu\text{V/m}$) = 20 log Emission Level ($\mu\text{V/m}$)

NOTE 2 - The tighter limit applies at the band edges.

NOTE 3 - Distance refers to the distance in meters between the measuring instrument antenna and the closed point of any part of the device or system.

NOTE 4 - The limits shown are based on Quasi-peak value detector.

4.4 Test Configuration

The configuration of the EUT and peripherals are same as those used in conducted emission test.

Please refer to Sec.3.4.

4.5 Operating Condition of EUT

Same as conducted emission test which is listed in Sec.3.5, except for the test setup replaced by Sec.4.2.

4.6 Test Procedures

The EUT and peripherals were placed on a FRP turntable that is 0.8 meter above ground. The FRP turntable rotated 360 degrees to determine the position of the maximum emission level. The EUT was set 3 meters away from the receiving antenna, which was mounted on an antenna tower. Broadband antenna (Calibrated Bilog Antenna) was used as receiving antenna. The antenna moved up and down between 1 meter and 4 meters to find out the maximum emission level. Both horizontal and vertical polarizations of the antenna were set on measurement. In order to find the maximum emission, all of the interference cables were manipulated according to ANSI C63.4:2003 requirements during radiated emission test.

The bandwidth of Test Receiver R&S ESVS10 was set at 120 kHz.

The frequency range from 30 MHz to 1000MHz was checked for all test modes.

The test modes were done on radiated disturbance test and all the test results are listed in Sec.4.7.

4.7 Test Results

<PASS>

The frequency and amplitude of the highest radiated emission relative the limit is reported. All the emissions not reported below are too low against the FCC limit.

Test Mode	Data Page
D-Sub 640*480@60Hz	P22
D-Sub 800*600@60Hz	P23
D-Sub 1024*768@60Hz	P24
HDMI 640*480@60Hz	P25
HDMI 800*600@60Hz	P26
HDMI 1024*768@60Hz	P27

NOTE 1 – Emission Level = Antenna Factor + Cable Loss + Meter Reading.

NOTE 2 – The emission levels that are 20dB below the official limit are not reported.

NOTE 3 – 0° was the table front facing the antenna. Degree is calculated from 0° clockwise facing the antenna.

NOTE 4 – The worst case is for D-Sub 640*480@60Hz test mode. The worst emission at horizontal polarization was detected at 914.640 MHz with corrected signal level of 42.66 dB ($\mu\text{V}/\text{m}$) (limit is 46.00dB ($\mu\text{V}/\text{m}$)), when the antenna was 1.50 m height and the turntable was at 140°. The worst emission at vertical polarization was detected at 36.790 MHz with corrected signal level of 36.83 dB ($\mu\text{V}/\text{m}$) (limit is 40.00 dB ($\mu\text{V}/\text{m}$)), when the antenna was 1.00 m height and the turntable was at 340°.

EUT : LCD TV Temperature : 22°C

Model No. : LTDN42T18GUS Humidity : 60%RH

Serial No. : E2010050701 Date of Test : May 19, 2010

Test Mode : D-Sub 640*480@60Hz

Polarization	Frequency (MHz)	Meter Reading dB (μV)	Antenna Factor (dB/m)	Cable Loss (dB)	Emission Level dB (μV/m)	Limits dB (μV/m)	Margin (dB)
Horizontal	46.490	17.17	10.52	0.76	28.45	40.00	11.55
	135.730	19.57	12.28	1.19	33.04	43.50	10.46
	487.840	20.08	17.75	2.24	40.07	46.00	5.93
	546.040	21.63	18.52	2.35	42.50	46.00	3.50
	584.840	18.92	19.03	2.43	40.38	46.00	5.62
	914.640	17.63	21.81	3.22	42.66	46.00	3.34
Vertical	36.790	20.34	15.80	0.69	36.83	40.00	3.17
	121.180	19.64	12.95	1.13	33.72	43.50	9.78
	179.380	21.90	9.92	1.37	33.19	43.50	10.31
	450.980	20.79	17.23	2.17	40.19	46.00	5.81
	546.040	20.39	18.52	2.35	41.26	46.00	4.74
	906.880	16.06	21.76	3.04	40.86	46.00	5.14

TEST ENGINEER: RAVEN JIN

EUT : LCD TV Temperature : 22°C

Model No. : LTDN42T18GUS Humidity : 60%RH

Serial No. : E2010050701 Date of Test : May 19, 2010

Test Mode : D-Sub 800*600@60Hz

Polarization	Frequency (MHz)	Meter Reading dB (μ V)	Antenna Factor (dB/m)	Cable Loss (dB)	Emission Level dB (μ V/m)	Limits dB (μ V/m)	Margin (dB)
Horizontal	46.490	21.97	10.52	0.76	33.25	40.00	6.75
	133.790	22.15	12.35	1.18	35.68	43.50	7.82
	366.590	17.20	15.77	1.98	34.95	46.00	11.05
	492.690	19.84	17.80	2.25	39.89	46.00	6.11
	547.98	20.65	18.55	2.35	41.55	46	4.45
	585.123	21.09	18.93	2.43	42.45	46.00	3.55
Vertical	37.810	20.20	15.90	0.69	36.79	40.00	3.21
	43.580	22.03	11.88	0.74	34.65	40.00	5.35
	133.790	22.01	12.35	1.18	35.54	43.50	7.96
	213.330	20.30	11.30	1.49	33.09	43.50	10.41
	546.040	19.13	18.52	2.35	40.00	46.00	6.00
	590.660	16.63	19.11	2.43	38.17	46.00	7.83

TEST ENGINEER: RAVEN JIN

EUT : LCD TV Temperature : 22°C

Model No. : LTDN42T18GUS Humidity : 60%RH

Serial No. : E2010050701 Date of Test : May 19, 2010

Test Mode : D-Sub 1024*768@60Hz

Polarization	Frequency (MHz)	Meter Reading dB (μV)	Antenna Factor (dB/m)	Cable Loss (dB)	Emission Level dB (μV/m)	Limits dB (μV/m)	Margin (dB)
Horizontal	80.440	21.29	7.85	0.95	30.09	40.00	9.91
	87.230	26.32	8.96	0.98	36.26	40.00	3.74
	174.530	25.67	10.07	1.35	37.09	43.50	6.41
	218.180	24.80	11.52	1.51	37.83	46.00	8.17
	547.980	20.78	18.55	2.35	41.68	46.00	4.32
	586.780	21.18	19.06	2.43	42.67	46.00	3.33
Vertical	36.790	19.18	15.80	0.69	35.67	40.00	4.33
	87.230	25.36	8.96	0.98	35.30	40.00	4.70
	153.190	24.61	11.04	1.25	36.90	43.50	6.60
	175.500	23.61	10.02	1.36	34.99	43.50	8.51
	546.040	19.71	18.52	2.35	40.58	46.00	5.42
	914.640	16.44	21.81	3.22	41.47	46.00	4.53

TEST ENGINEER: RAVEN JIN

EUT : LCD TV Temperature : 22°C

Model No. : LTDN42T18GUS Humidity : 60%RH

Serial No. : E2010050701 Date of Test : May 19, 2010

Test Mode : HDMI 640*480@60Hz

Polarization	Frequency (MHz)	Meter Reading dB (μ V)	Antenna Factor (dB/m)	Cable Loss (dB)	Emission Level dB (μ V/m)	Limits dB (μ V/m)	Margin (dB)
Horizontal	50.370	15.05	8.85	0.70	24.60	40.00	15.40
	87.230	24.16	8.96	1.00	34.12	40.00	5.88
	152.220	22.08	11.09	1.25	34.42	43.50	9.08
	440.310	19.22	17.09	2.30	38.61	46.00	7.39
	585.810	18.22	19.06	2.70	39.98	46.00	6.02
	879.720	13.67	21.49	3.39	38.55	46.00	7.45
Vertical	32.910	14.42	17.95	0.64	33.01	40.00	6.99
	87.230	21.61	8.96	1.00	31.57	40.00	8.43
	152.220	23.25	11.09	1.25	35.59	43.50	7.91
	440.310	19.01	17.09	2.30	38.40	46.00	7.60
	659.530	15.44	19.51	2.86	37.81	46.00	8.19
	953.440	10.84	22.11	3.53	36.48	46.00	9.52

TEST ENGINEER: RAVEN JIN

EUT : LCD TV Temperature : 22°C

Model No. : LTDN42T18GUS Humidity : 60%RH

Serial No. : E2010050701 Date of Test : May 19, 2010

Test Mode : HDMI 800*600@60Hz

Polarization	Frequency (MHz)	Meter Reading dB (μ V)	Antenna Factor (dB/m)	Cable Loss (dB)	Emission Level dB (μ V/m)	Limits dB (μ V/m)	Margin (dB)
Horizontal	50.370	16.18	8.85	0.70	25.73	40.00	14.27
	94.020	19.76	10.27	1.05	31.08	43.50	12.42
	147.370	24.74	11.51	1.22	37.47	43.50	6.03
	374.350	17.95	15.95	2.13	36.03	46.00	9.97
	599.390	17.69	19.20	2.74	39.63	46.00	6.37
	898.150	14.92	21.67	3.44	40.03	46.00	5.97
Vertical	49.400	19.86	9.16	0.70	29.72	40.00	10.28
	94.020	15.38	10.27	1.05	26.70	43.50	16.80
	187.140	24.64	10.17	1.47	36.28	43.50	7.22
	449.040	14.39	17.20	2.32	33.91	46.00	12.09
	599.390	17.25	19.20	2.74	39.19	46.00	6.81
	972.840	8.87	22.22	3.58	34.67	54.00	19.33

TEST ENGINEER: RAVEN JIN

EUT : LCD TV Temperature : 22°C

Model No. : LTDN42T18GUS Humidity : 60%RH

Serial No. : E2010050701 Date of Test : May 19, 2010

Test Mode : HDMI 1024*768@60Hz

Polarization	Frequency (MHz)	Meter Reading dB (μV)	Antenna Factor (dB/m)	Cable Loss (dB)	Emission Level dB (μV/m)	Limits dB (μV/m)	Margin (dB)
Horizontal	50.370	14.85	8.85	0.70	24.40	40.00	15.60
	87.230	22.63	8.96	1.00	32.59	40.00	7.41
	152.220	23.50	11.09	1.25	35.84	43.50	7.66
	371.440	19.63	15.88	2.12	37.63	46.00	8.37
	592.600	16.13	19.11	2.72	37.96	46.00	8.04
	890.390	13.31	21.60	3.42	38.33	46.00	7.67
Vertical	31.940	12.25	18.49	0.64	31.38	40.00	8.62
	87.230	21.66	8.96	1.00	31.62	40.00	8.38
	172.590	25.16	10.11	1.38	36.65	43.50	6.85
	445.160	13.41	17.14	2.31	32.86	46.00	13.14
	592.600	15.70	19.11	2.72	37.53	46.00	8.47
	890.390	10.12	21.60	3.42	35.14	46.00	10.86

TEST ENGINEER: RAVEN JIN

5 DEVIATION TO TEST SPECIFICATIONS

None.

6 DEBUG DESCRIPTION

The following components are used during the countermeasure procedures:

Name	M/N	Manufacturer	Location
Gasket	DAA1002\ROH	QDJOINSET S&T CO., LTD	See Appendix II Figure 24
Gasket	20X20X22T\ROH	QDJOINSET S&T CO., LTD	See Appendix II Figure 25

Note: We had required the applicant and manufacturer that all electrical and mechanical devices employed for spurious radiation suppression, including any modifications made during certification testing, must be incorporated in each unit marked

TEST ENGINEER:

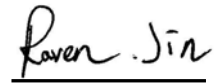

(RAVEN JIN)