

**FCC 47 CFR PART 15 SUBPART B**  
**CERTIFICATION TEST REPORT**

**Product name: LED LCD TV**

**MODEL No.: 32H5507, 32H5D, 32H5D1, 32H5D2, 32H5C,  
32H5D3, 32H520D, 32H530D, 32H550D, 32H560D,  
32H5020D, 32H5030D, 32H5050D, 32H5060D**

**FCC ID: W9HLCDC0042**

**REPORT NO: ES170227007E**

**ISSUE DATE: March 07, 2017**

*Prepared for*

**Hisense Electric Co., Ltd.**  
**No. 218 Qianwangang Road, Economy&Technology**  
**DevelopmentZone, Qingdao 266071**

*Prepared by*

**EMTEK (SHENZHEN) CO., LTD.**

**Bldg 69, Majialong Industry Zone, Nanshan District, Shenzhen,**  
**Guangdong, China**  
**TEL: 86-755-26954280**  
**FAX: 86-755-26954282**

## TABLE OF CONTENT

Test Report Description	Page
<b>1. SUMMARY OF TEST RESULT .....</b>	<b>5</b>
<b>2. GENERAL INFORMATION .....</b>	<b>6</b>
2.1. DESCRIPTION OF DEVICE (EUT).....	6
2.2. DESCRIPTION OF TEST FACILITY .....	6
2.3. DESCRIPTION OF SUPPORT DEVICE.....	7
2.4. DESCRIPTION OF CABLE .....	7
2.5. MEASUREMENT UNCERTAINTY.....	7
<b>3. MEASURING DEVICE AND TEST EQUIPMENT .....</b>	<b>8</b>
<b>4. CONDUCTED EMISSION MEASUREMENT .....</b>	<b>9</b>
4.1. BLOCK DIAGRAM OF TEST SETUP .....	9
4.2. MEASURING STANDARD.....	9
4.3. POWER LINE CONDUCTED EMISSION LIMITS (CLASS B) .....	9
4.4. EUT CONFIGURATION ON MEASUREMENT .....	9
4.5. OPERATING CONDITION OF EUT .....	9
4.6. TEST PROCEDURE.....	10
4.7. MEASURING RESULTS .....	10
<b>5. RADIATED EMISSION MEASUREMENT .....</b>	<b>13</b>
5.1. BLOCK DIAGRAM OF TEST SETUP .....	13
5.2. MEASURING STANDARD.....	14
5.3. RADIATED EMISSION LIMITS (CLASS B).....	14
5.4. EUT CONFIGURATION ON MEASUREMENT .....	14
5.5. OPERATING CONDITION OF EUT .....	14
5.6. TEST PROCEDURE.....	14
5.7. MEASURING RESULTS .....	15
<b>6. RADIATED SPURIOUS EMISSION FOR WIFI MODULE .....</b>	<b>20</b>
6.1. APPLICABLE STANDARD .....	20
6.2. CONFORMANCE LIMIT.....	20
6.3. TEST CONFIGURATION .....	20
6.4. TEST PROCEDURE.....	20
6.5. TEST RESULTS .....	21

## TEST REPORT DESCRIPTION

Applicant : Hisense Electric Co., Ltd.  
No. 218 Qianwangang Road, Economy&Technology DevelopmentZone,  
Qingdao 266071

Manufacturer : Hisense Electric Co., Ltd.  
No. 218 Qianwangang Road, Economy&Technology DevelopmentZone,  
Qingdao 266071

Factory 1 : Guangdong Hisense Electronics Co., Ltd.  
Zone B, No. 8 Hisense Road, Advanced Manufacturing Jiangsha  
Demonstration Park, Jiangmen City, Guangdong Province, PRC

Factory 2 : HISENSE ELECTRONICA MEXICO, S.A. DE C.V.  
Blvd. Sharp #3510 Parque Industrial Rosarito, C.P. 22710 Playas de  
Rosarito, Baja California, Mexico

Trademark : HISENSE

EUT : LED LCD TV

Model No. : 32H5507, 32H5D, 32H5D1, 32H5D2, 32H5C, 32H5D3, 32H520D, 32H530D,  
32H550D, 32H560D, 32H5020D, 32H5030D, 32H5050D, 32H5060D

Power Supply : AC 120V, 50W, 60Hz

### Measurement Procedure Used:

FCC Rules and Regulations Part 15: 2016 Subpart B Class B & FCC / ANSI C63.4-2014

The device described above is tested by EMTEK (SHENZHEN) CO., LTD. to determine the maximum emission levels emanating from the device and the severe levels of the device can endure and its performance criterion. The measurement results are contained in this test report and EMTEK (SHENZHEN) CO., LTD. is assumed full of responsibility for the accuracy and completeness of these measurements. Also, this report shows that the EUT (Equipment Under Test) is technically compliant with the FCC requirements.

This report applies to above tested sample only and shall not be reproduced in part without written approval of EMTEK (SHENZHEN) CO., LTD.

Date of Test : February 04, 2017 to March 07, 2017

Prepared by :   
Sevin Li/Editor

Reviewer :   
Joe Xia/Supervisor

Approved & Authorized Signer :   
Lisa Wang/Manager

### Modified Information

Version	Report No.	Revision Date	Summary
Ver.1.0	ES170227007E	/	Original Report

## 1. SUMMARY OF TEST RESULT

<b>EMISSION</b>		
Description of Test Item	Standard & Limits	Results
Conducted Disturbance at Mains Terminals	FCC Part 15, Subpart B, Class B ANSI C63.4: 2014	Pass
Radiated Disturbance	FCC Part 15, Subpart B, Class B ANSI C63.4: 2014	Pass
Radiated Spurious Emission	15.247(d) 15.209 ANSI C63.10: 2013	Pass
Note: N/A is an abbreviation for Not Applicable.		

## 2. GENERAL INFORMATION

### 2.1. Description of Device (EUT)

EUT	:	LED LCD TV
Model Number	:	32H5507, 32H5D, 32H5D1, 32H5D2, 32H5C, 32H5D3, 32H520D, 32H530D, 32H550D, 32H560D, 32H5020D, 32H5030D, 32H5050D, 32H5060D (Note: These models are identical in circuitry and electrical, mechanical and physical construction; the only difference is the model number. for trading purpose. We prepare 32H5507 for all test.)
Test Voltage	:	AC 120V/60Hz
Applicant Address	:	Hisense Electric Co., Ltd. No. 218 Qianwangang Road, Economy&Technology DevelopmentZone, Qingdao 266071
Manufacturer Address	:	Hisense Electric Co., Ltd. No. 218 Qianwangang Road, Economy&Technology DevelopmentZone, Qingdao 266071
Factory 1 Address	:	Guangdong Hisense Electronics Co., Ltd. Zone B, No. 8 Hisense Road, Advanced Manufacturing Jiangsha Demonstration Park, Jiangmen City, Guangdong Province, PRC
Factory 2 Address	:	HISENSE ELECTRONICA MEXICO, S.A. DE C.V. Blvd. Sharp #3510 Parque Industrial Rosarito, C.P. 22710 Playas de Rosarito, Baja California, Mexico
Date of Received	:	February 04, 2017
Date of Test	:	February 04, 2017 to March 07, 2017

### 2.2. Description of Test Facility

Site Description	:	Accredited by CNAS, 2016.10.24 The certificate is valid until 2022.10.28 The Laboratory has been assessed and proved to be in compliance with CNAS-CL01:2006 (identical to ISO/IEC 17025:2005) The Certificate Registration Number is L2291. Accredited by TUV Rheinland Shenzhen 2010.5.25 The Laboratory has been assessed according to the requirements ISO/IEC 17025.
	:	Accredited by FCC, July 13, 2016 The Certificate Registration Number is 709623.
	:	Accredited by Industry Canada, November 15, 2015 The Certificate Registration Number is 4480A-2.
Name of Firm	:	EMTEK (SHENZHEN) CO., LTD.
Site Location	:	Bldg 69, Majialong Industry Zone, Nanshan District, Shenzhen, Guangdong, China

### 2.3. Description of Support Device

PC : Manufacturer: LENOVO  
M/N: 9702  
S/N: L3C4410  
CE, FCC: DOC

Keyboard : Manufacturer: LENOVO  
M/N: KU-0225  
S/N:0585494  
CE, FCC: DOC

Mouse : Manufacturer: LENOVO  
M/N: MO28UOL  
S/N:44G7862 068  
CE, FCC: DOC

Dummy load : Manufacturer: Cultraview  
M/N: CVNS1200

### 2.4. Description of Cable

Cables			
No.	Type	Length	Remark
1.	Power Cable	1.5 m	Unshielded
2.	HDMI Cable*3	0.8 m	Unshielded
3.	AV Cable	1.0 m	Unshielded

### 2.5. Measurement Uncertainty

Test Item	Uncertainty
Conducted Emission Uncertainty	: 2.96dB(9k~150kHz Conduction 1#) 2.74dB(150k-30MHz Conduction 1#)
Radiated Emission Uncertainty (3m Chamber)	: 3.78dB (30M~1GHz Polarize: H) 4.27dB (30M~1GHz Polarize: V) 4.46dB (1~6GHz)

### 3. MEASURING DEVICE AND TEST EQUIPMENT

#### 3.1.1. Conducted Emission Test Equipment

EQUIPMENT TYPE	MFR	MODEL NUMBER	SERIAL NUMBER	LAST CAL.
Test Receiver	Rohde & Schwarz	ESCS30	828985/018	May 29, 2016
L.I.S.N.	Schwarzbeck	NNLK8129	8129203	May 28, 2016
50Ω Coaxial Switch	Anritsu	MP59B	M20531	May 29, 2016
Pulse Limiter	Rohde & Schwarz	ESH3-Z2	100006	May 28, 2016
Voltage Probe	Rohde & Schwarz	TK9416	N/A	May 28, 2016

#### 3.1.2. Radiated Emission Test Equipment

EQUIPMENT TYPE	MFR	MODEL NUMBER	SERIAL NUMBER	LAST CAL.
EMI Test Receiver	Rohde & Schwarz	ESU	1302.6005.26	May 29, 2016
Pre-Amplifier	HP	8447D	2944A07999	May 28, 2016
Bilog Antenna	Schwarzbeck	VULB9163	142	May 28, 2016
Loop Antenna	ARA	PLA-1030/B	1029	May 28, 2016
Horn Antenna	Schwarzbeck	BBHA 9170	BBHA9170399	May 28, 2016
Horn Antenna	Schwarzbeck	BBHA 9120	D143	May 28, 2016
Cable	Schwarzbeck	AK9513	ACRX1	May 29, 2016
Cable	Rosenberger	N/A	FP2RX2	May 29, 2016
Cable	Schwarzbeck	AK9513	CRPX1	May 29, 2016
Cable	Schwarzbeck	AK9513	CRRX2	May 29, 2016



## 4. CONDUCTED EMISSION MEASUREMENT

### 4.1. Block Diagram of Test Setup

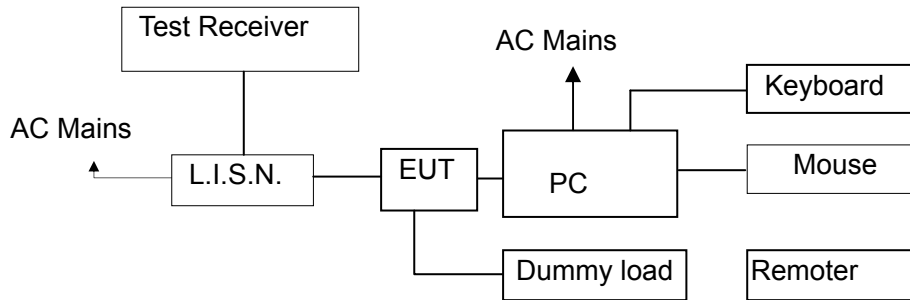

(EUT: LED LCD TV)

### 4.2. Measuring Standard

FCC Part 15, Subpart B, Class BANSI C63.4: 2014

### 4.3. Power Line Conducted Emission Limits (Class B)

Frequency (MHz)	Limit (dB $\mu$ V)	
	Quasi-peak Level	Average Level
0.15 ~ 0.50	66.0 ~ 56.0 *	56.0 ~ 46.0 *
0.50 ~ 5.00	56.0	46.0
5.00 ~ 30.00	60.0	50.0

NOTE1-The lower limit shall apply at the transition frequencies.  
NOTE2-The limit decreases linearly with the logarithm of the frequency in the range 0.15MHz to 0.50MHz.

### 4.4. EUT Configuration on Measurement

The following equipments are installed on Conducted Emission Measurement to meet FCC requirements and operating in a manner which tends to maximize its emission characteristics in a normal application.

EUT : LED LCD TV  
Model Number : 32H5507

### 4.5. Operating Condition of EUT

4.5.1. Setup the EUT as shown on Section 4.1.

4.5.2. Turn on the power of all equipments.

4.5.3. Let the EUT work in measuring mode (HDMI 1 IN, HDMI 2 ARC, HDMI 3 IN, LAN Ping) and measure it. (The HDMI Port connect to PC HDMI Port via HDMI line; The LAN Port connect to PC LAN Port via Ethernet cable)

#### 4.6. Test Procedure

The EUT is put on the plane 0.8m high above the ground by insulating support and connected to the AC mains through Line Impedance Stability Network (L.I.S.N). This provided a 50ohm coupling impedance for the tested equipments. Both sides of AC line are investigated to find out the maximum conducted emission according to the FCC regulations during conducted emission measurement.

The bandwidth of the field strength meter (R&S Test Receiver ESCS30) is set at 9kHz in 150kHz~30MHz and 200Hz in 9kHz~150kHz.

The frequency range from 150kHz to 30MHz is investigated.

#### 4.7. Measuring Results

**PASS.**

Please refer to the following pages.

The worst mode is HDMI 1 IN, and the mode is the LED LCD TV connected to PC. Please refer to the following pages.

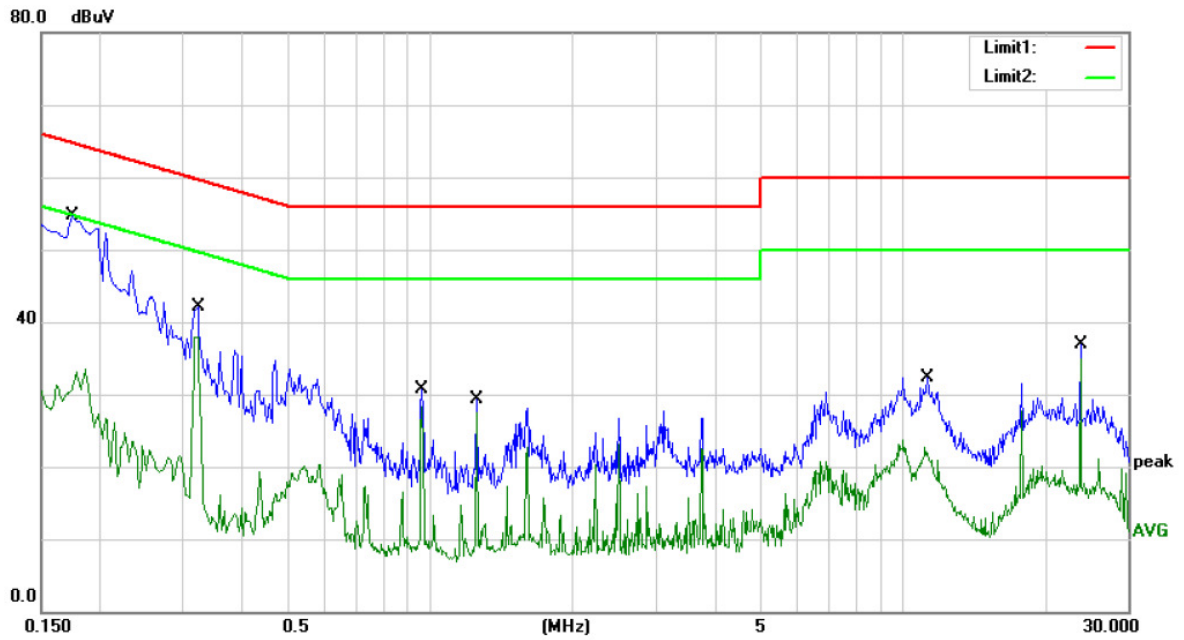

Site Conduction #2 Phase: **L1** Temperature: 21  
 Limit: (CE)FCC PART 15 class B\_QP Power: AC 120V/60Hz Humidity: 53 %  
 Mode: HDMI 1 IN  
 Note:

No.	Mk.	Freq.	Reading Level	Correct Factor	Measurement	Limit	Over	Detector	Comment
		MHz	dBuV	dB	dBuV	dBuV	dB		
1	*	0.1740	45.03	9.62	54.65	64.77	-10.12	QP	
2		0.1740	23.91	9.62	33.53	54.77	-21.24	AVG	
3		0.3220	32.48	9.67	42.15	59.66	-17.51	QP	
4		0.3220	28.27	9.67	37.94	49.66	-11.72	AVG	
5		0.9620	20.93	9.84	30.77	56.00	-25.23	QP	
6		0.9620	18.52	9.84	28.36	46.00	-17.64	AVG	
7		1.2540	19.54	9.85	29.39	56.00	-26.61	QP	
8		1.2540	17.66	9.85	27.51	46.00	-18.49	AVG	
9		11.2660	21.66	10.67	32.33	60.00	-27.67	QP	
10		11.2660	12.00	10.67	22.67	50.00	-27.33	AVG	
11		23.8180	26.16	10.78	36.94	60.00	-23.06	QP	
12		23.8180	24.11	10.78	34.89	50.00	-15.11	AVG	

\*:Maximum data x:Over limit !:over margin Comment: Factor build in receiver. Operator: HJ

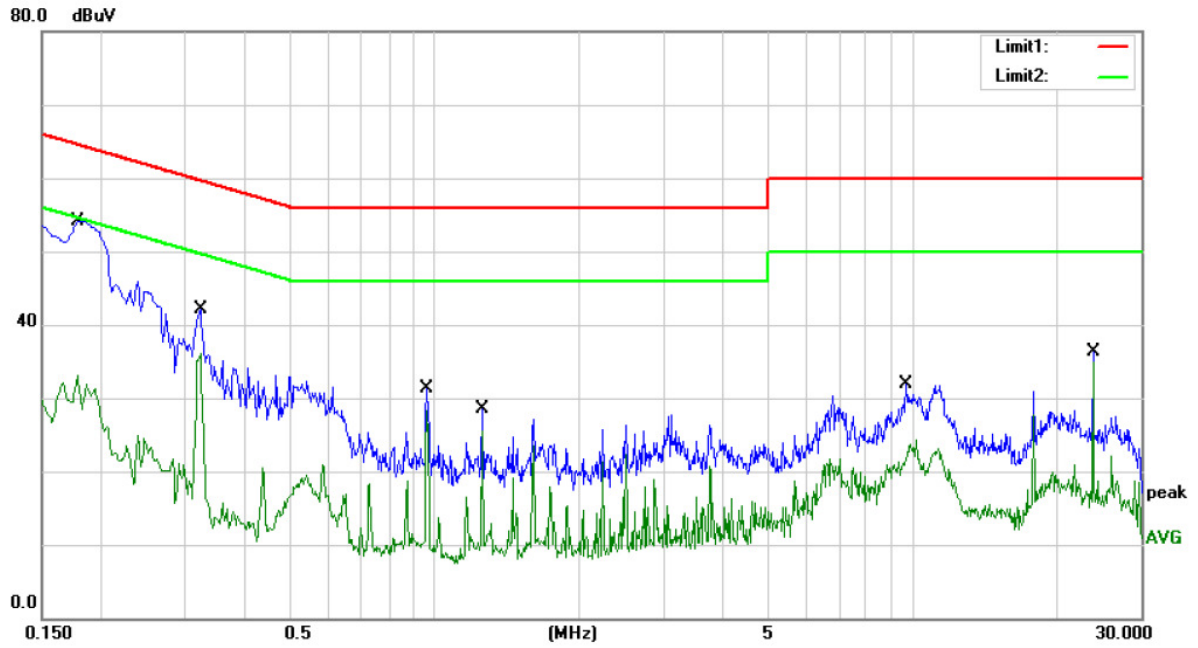

Site Conduction #2

Phase: **N**

Temperature: 21

Limit: (CE)FCC PART 15 class B\_QP

Power: AC 120V/60Hz

Humidity: 53 %

Mode: HDMI 1 IN

Note:

No.	Mk.	Freq.	Reading Level	Correct Factor	Measurement	Limit	Over	Detector	Comment
		MHz	dBuV	dB	dBuV	dBuV	dB		
1	*	0.1780	44.50	9.63	54.13	64.58	-10.45	QP	
2		0.1780	23.39	9.63	33.02	54.58	-21.56	AVG	
3		0.3220	32.51	9.67	42.18	59.66	-17.48	QP	
4		0.3220	26.40	9.67	36.07	49.66	-13.59	AVG	
5		0.9620	21.38	9.84	31.22	56.00	-24.78	QP	
6		0.9620	18.47	9.84	28.31	46.00	-17.69	AVG	
7		1.2540	18.61	9.85	28.46	56.00	-27.54	QP	
8		1.2540	15.69	9.85	25.54	46.00	-20.46	AVG	
9		9.6660	21.28	10.61	31.89	60.00	-28.11	QP	
10		9.6660	13.62	10.61	24.23	50.00	-25.77	AVG	
11		23.8180	25.52	10.78	36.30	60.00	-23.70	QP	
12		23.8180	24.14	10.78	34.92	50.00	-15.08	AVG	

\*:Maximum data    x:Over limit    !:over margin    Comment: Factor build in receiver.    Operator: HJ

## 5. RADIATED EMISSION MEASUREMENT

### 5.1. Block Diagram of Test Setup

#### 5.1.1. Block diagram of EUT System

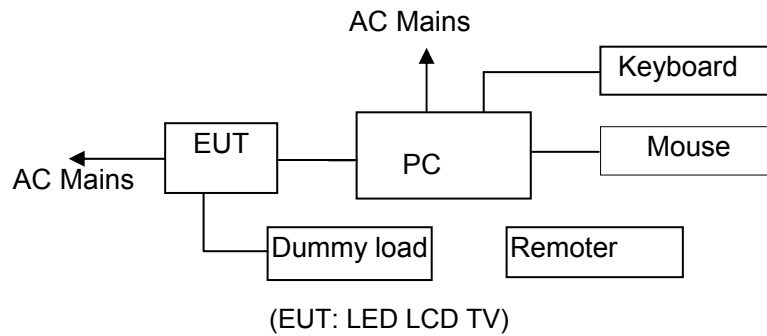

#### 5.1.2. Block diagram of test setup (In chamber)

30MHz-1GHz:

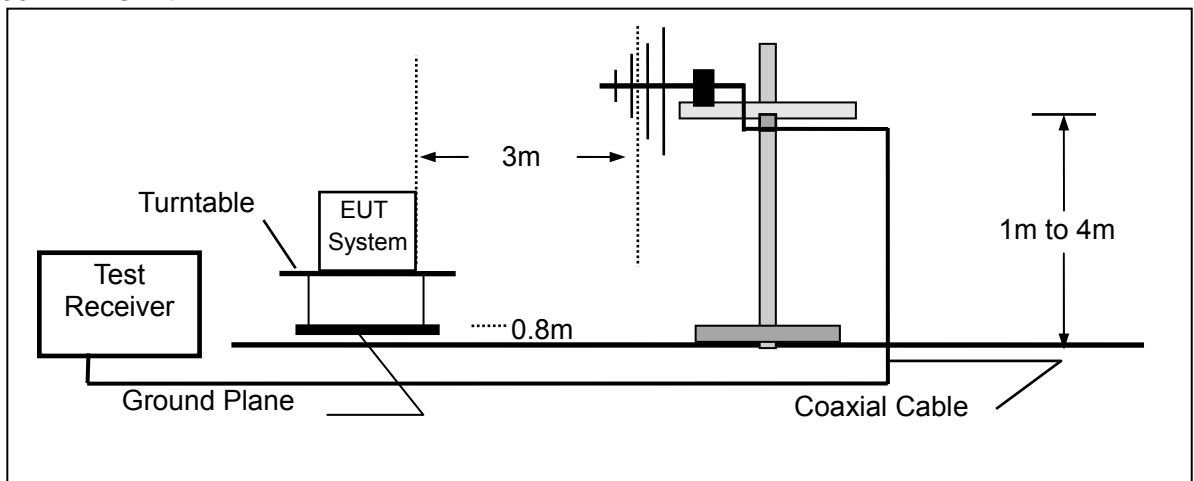

1GHz-6GHz:

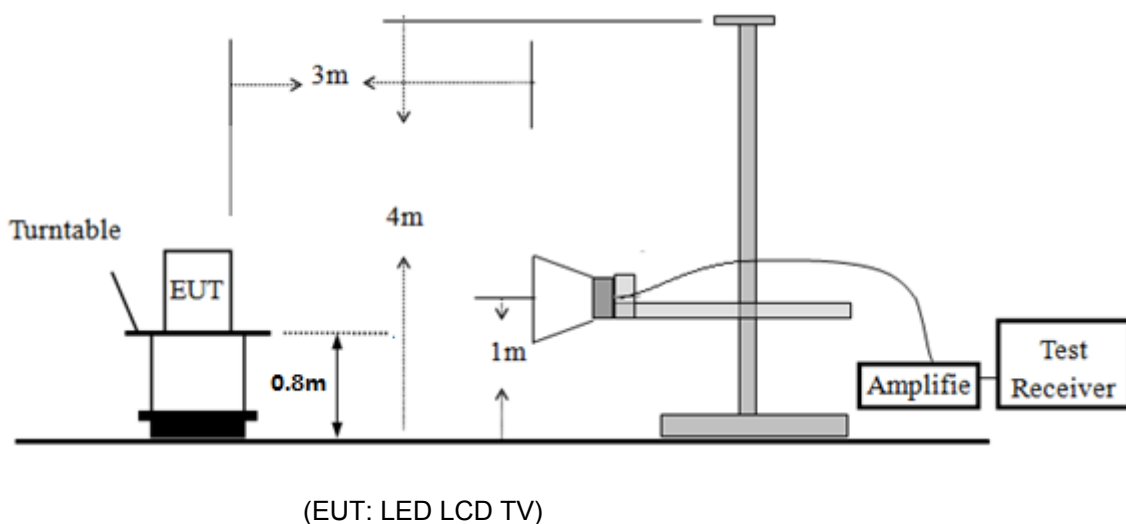

## 5.2. Measuring Standard

FCC Part 15, Subpart B, Class B ANSI C63.4: 2014

## 5.3. Radiated Emission Limits (Class B)

Frequency MHz	Distance Meters	Field Strengths Limit	
		$\mu\text{V}/\text{m}$	$\text{dB}(\mu\text{V})/\text{m}@3\text{M}$
30 ~ 88	10	100	40
88 ~ 216	10	150	43.5
216 ~ 960	10	200	46
960 ~ 1000	10	500	54

Frequency (GHz)	Distance (Meters)	Field Strengths Limit	
		Average ( $\text{dB}\mu\text{V}/\text{m}$ )	Peak ( $\text{dB}\mu\text{V}/\text{m}$ )
1~6	3	54	74

Remark: (1) Emission level ( $\text{dB}\mu\text{V}$ ) =  $20 \log$  Emission level  $\mu\text{V}/\text{m}$   
 (2) The smaller limit shall apply at the cross point between two frequency bands.  
 (3) Distance is the distance in meters between the measuring instrument, antenna and the closest point of any part of the device or system.

## 5.4. EUT Configuration on Measurement

The FCC Class B regulations test method must be used to find the maximum emission during radiated emission measurement.

EUT : LED LCD TV  
 Model Number : 32H5507

## 5.5. Operating Condition of EUT

5.5.1. Setup the EUT as shown on Section 5.1.

5.5.2. Turn on the power of all equipments.

5.5.3. Let the EUT work in measuring mode (HDMI 1 IN, HDMI 2 ARC, HDMI 3 IN, LAN Ping) and measure it. (The HDMI Port connect to PC HDMI Port via HDMI line; The LAN Port connect to PC LAN Port via Ethernet cable)

## 5.6. Test Procedure

The EUT is placed on a turn table which is 0.8 meter high above the ground. The turn table can rotate 360 degrees to determine the position of the maximum emission level. The EUT is set 3 meters away from the receiving antenna which is mounted on a antenna tower. The antenna can be moved up and down from 1 to 4 meters to find out the maximum emission level. Bilog antenna (calibrated by Dipole Antenna) is used as a receiving antenna. Both horizontal and vertical polarization of the antenna are set on test.

The bandwidth of the Receiver (ESU26) is set at 120kHz.

## 5.7. Measuring Results

**PASS.**

The frequency range from 30MHz to 6000MHz is investigated.

The worst mode is HDMI 1 IN, and the mode is the LED LCD TV connected to PC. Please refer to the following pages.

Please refer to the following pages.

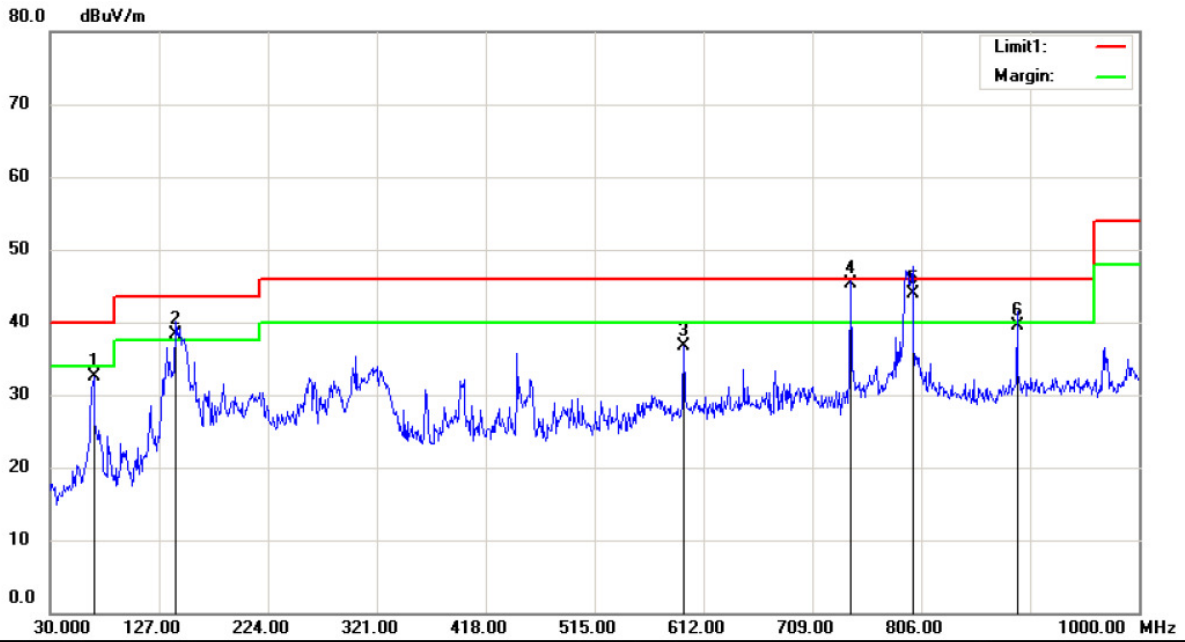

Site 3m Chamber #1      Polarization: **Horizontal**      Temperature: 22 C  
 Limit: (RE)FCC PART 15 CLASS B      Power: AC 120V/60Hz      Humidity: 50 %  
 Mode:HDMI 1 IN  
 Note:

No.	Mk.	Freq.	Reading Level	Correct Factor	Measurement	Limit	Over	Antenna Height	Table Degree	
		MHz	dBuV	dB	dBuV/m	dBuV/m	dB	cm	degree	Comment
1		68.8000	48.04	-15.55	32.49	40.00	-7.51	QP		
2	!	141.5500	54.60	-16.20	38.40	43.50	-5.10	QP		
3		594.5400	39.79	-3.09	36.70	46.00	-9.30	QP		
4	*	742.9500	46.42	-1.02	45.40	46.00	-0.60	QP		
5	!	798.2400	44.17	-0.27	43.90	46.00	-2.10	QP		
6		891.3600	38.74	0.86	39.60	46.00	-6.40	QP		

\*:Maximum data    x:Over limit    !:over margin

Operator: KK



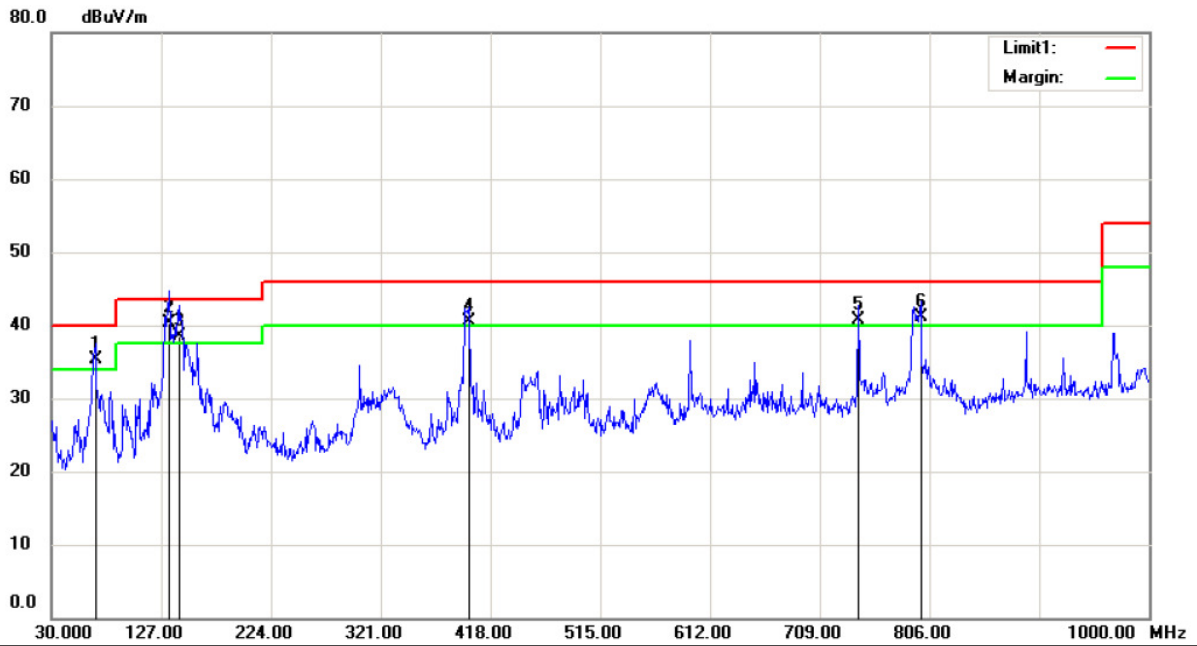

Site: 3m Chamber #1      Polarization: **Vertical**      Temperature: 22 C  
 Limit: (RE)FCC PART 15 CLASS B      Power: AC 120V/60Hz      Humidity: 50 %  
 Mode:HDMI 1 IN  
 Note:

No.	Mk.	Freq.	Reading Level	Correct Factor	Measurement	Limit	Over	Antenna Height	Table Degree	
		MHz	dBuV	dB	dBuV/m	dBuV/m	dB	cm	degree	Comment
1	!	68.8000	50.95	-15.55	35.40	40.00	-4.60	QP		
2	*	133.7900	55.84	-15.54	40.30	43.50	-3.20	QP		
3	!	142.5200	54.81	-16.21	38.60	43.50	-4.90	QP		
4	!	398.6000	49.14	-8.64	40.50	46.00	-5.50	QP		
5	!	742.9500	41.72	-1.02	40.70	46.00	-5.30	QP		
6	!	798.2400	41.47	-0.27	41.20	46.00	-4.80	QP		

\*:Maximum data    x:Over limit    !:over margin

Operator: KK

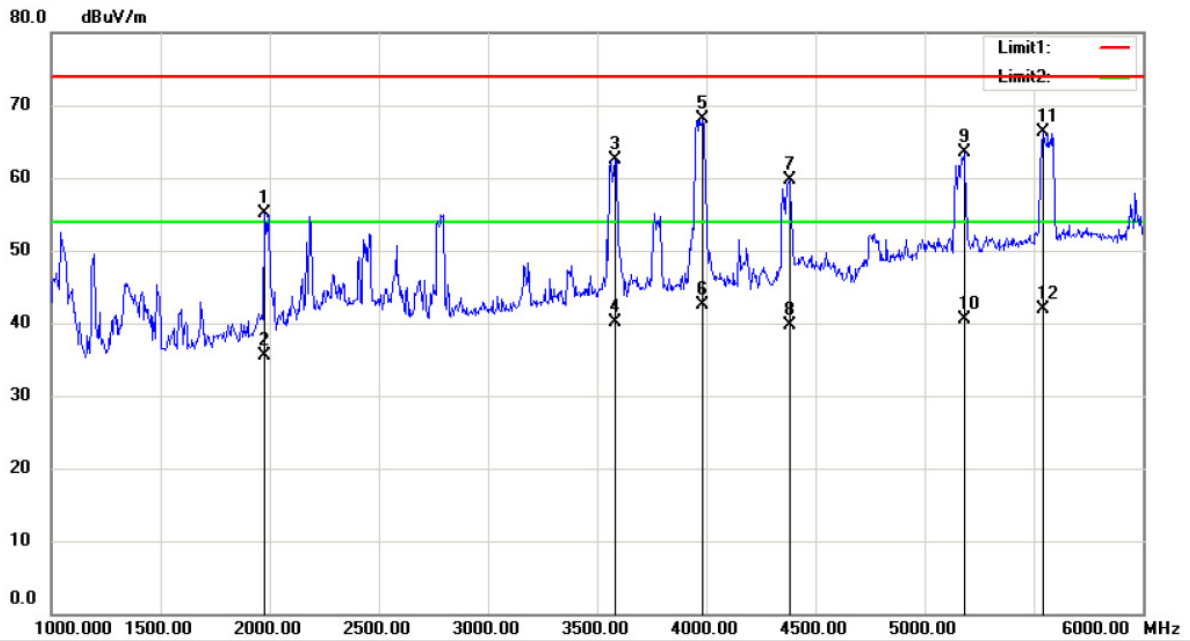

Site 3m Chamber #1      Polarization: **Horizontal**      Temperature: 22 C  
 Limit: (RE)FCC PART 15 CLASS B PEAK      Power: AC 120V/60Hz      Humidity: 50 %  
 Mode:HDMI 1 IN  
 Note:

No.	Mk.	Freq.	Reading Level	Correct Factor	Measurement	Limit	Over	Antenna Height	Table Degree	
		MHz	dBuV	dB	dBuV/m	dBuV/m	dB	cm	degree	Comment
1		1975.000	64.32	-9.27	55.05	74.00	-18.95			peak
2		1975.000	44.87	-9.27	35.60	54.00	-18.40			AVG
3		3580.000	66.19	-3.71	62.48	74.00	-11.52			peak
4		3580.000	43.81	-3.71	40.10	54.00	-13.90			AVG
5	*	3985.000	70.44	-2.25	68.19	74.00	-5.81			peak
6		3985.000	44.75	-2.25	42.50	54.00	-11.50			AVG
7		4380.000	60.89	-1.16	59.73	74.00	-14.27			peak
8		4380.000	40.96	-1.16	39.80	54.00	-14.20			AVG
9		5180.000	62.69	0.88	63.57	74.00	-10.43			peak
10		5180.000	39.72	0.88	40.60	54.00	-13.40			AVG
11		5545.000	64.82	1.57	66.39	74.00	-7.61			peak
12		5545.000	40.33	1.57	41.90	54.00	-12.10			AVG

\*:Maximum data    x:Over limit    !:over margin

Operator: KK



## 6. RADIATED SPURIOUS EMISSION FOR WIFI MODULE

WiFi Module FCC ID: PPQ-WN4640R

### 6.1. Applicable Standard

According to FCC Part 15.247(d) and 15.209 and KDB 558074 DTS 01 Meas. Guidance v03r05

### 6.2. Conformance Limit

According to FCC Part 15.247(d): radiated emissions which fall in the restricted bands, as defined in §15.205(a), must also comply with the radiated emission limits specified in §15.209(a) (see §15.205(c)).

According to FCC Part15.205, Restricted bands

MHz	MHz	MHz	GHz
0.090-0.110	16.42-16.423	399.9-410	4.5-5.15
10.495-0.505	16.69475-16.69525	608-614	5.35-5.46
2.1735-2.1905	16.80425-16.80475	960-1240	7.25-7.75
4.125-4.128	25.5-25.67	1300-1427	8.025-8.5
4.17725-4.17775	37.5-38.25	1435-1626.5	9.0-9.2
4.20725-4.20775	73-74.6	1645.5-1646.5	9.3-9.5
6.215-6.218	74.8-75.2	1660-1710	10.6-12.7
6.26775-6.26825	123-138	2200-2300	14.47-14.5
8.291-8.294	149.9-150.05	2310-2390	15.35-16.2
8.362-8.366	156.52475-156.52525	2483.5-2500	17.7-21.4
8.37625-8.38675	156.7-156.9	2690-2900	22.01-23.12
8.41425-8.41475	162.0125-167.17	3260-3267	23.6-24.0
12.29-12.293	167.72-173.2	3332-3339	31.2-31.8
12.51975-12.52025	240-285	3345.8-3358	36.43-36.5
12.57675-12.57725	322-335.4	3600-4400	(2)
13.36-13.41			

According to FCC Part15.205, the level of any transmitter spurious emission in Restricted bands shall not exceed the level of the emission specified in the following table

Restricted Frequency(MHz)	Field Strength ( $\mu\text{V}/\text{m}$ )	Field Strength ( $\text{dB}\mu\text{V}/\text{m}$ )	Measurement Distance
0.009-0.490	2400/F(KHz)	20 log ( $\mu\text{V}/\text{m}$ )	300
0.490-1.705	2400/F(KHz)	20 log ( $\mu\text{V}/\text{m}$ )	30
1.705-30	30	29.5	30
30-88	100	40	3
88-216	150	43.5	3
216-960	200	46	3
Above 960	500	54	3

### 6.3. Test Configuration

Test according to clause 7.2 radio frequency test setup 2

### 6.4. Test Procedure

This test is required for any spurious emission that falls in a Restricted Band, as defined in Section 15.205. It must be performed with the highest gain of each type of antenna proposed for use with the EUT. Use the following spectrum analyzer settings:



■ Spurious Emission Above 1GHz (1GHz to 25GHz)

All modes 802.11b/g/n have been tested, and the worst result 802.11b recorded was report as below:

Temperature :	26°C	Test Date :	March 02, 2017
Humidity :	60 %	Test By:	King Kong
Test mode:	802.11b	Frequency:	Channel 1: 2412MHz

Freq. (MHz)	Ant.Pol. H/V	Emission Level(dBuV/m)		Limit 3m(dBuV/m)		Over(dB)	
		PK	AV	PK	AV	PK	AV
4824.05	V	56.52	49.39	74.00	54.00	-17.48	-4.61
6700.35	V	53.78	46.51	74.00	54.00	-20.22	-7.49
9113.47	V	49.71	36.5	74.00	54.00	-24.29	-17.5
4824.33	H	56.85	48.67	74.00	54.00	-17.15	-5.33
6700.22	H	52.25	44.65	74.00	54.00	-21.75	-9.35
9113.40	H	51.2	37.99	74.00	54.00	-22.8	-16.01

Temperature :	26°C	Test Date :	March 02, 2017
Humidity :	60 %	Test By:	King Kong
Test mode:	802.11b	Frequency:	Channel 6: 2437MHz

Freq. (MHz)	Ant.Pol. H/V	Emission Level(dBuV/m)		Limit 3m(dBuV/m)		Over(dB)	
		PK	AV	PK	AV	PK	AV
4875.29	V	55.99	48.03	74.00	54.00	-18.01	-5.97
7576.85	V	54.51	44.86	74.00	54.00	-19.49	-9.14
10014.01	V	49.11	36.23	74.00	54.00	-24.89	-17.77
4874.8	H	57.18	48.05	74.00	54.00	-16.82	-5.95
7577.61	H	52.8	43.37	74.00	54.00	-21.2	-10.63
10013.42	H	50.82	37.29	74.00	54.00	-23.18	-16.71

Temperature :	26°C	Test Date :	March 02, 2017
Humidity :	60 %	Test By:	King Kong
Test mode:	802.11b	Frequency:	Channel 11: 2462MHz

Freq. (MHz)	Ant.Pol. H/V	Emission Level(dBuV/m)		Limit 3m(dBuV/m)		Over(dB)	
		PK	AV	PK	AV	PK	AV
4924.98	V	54.62	48.58	74.00	54.00	-19.38	-5.42
7137.01	V	52.87	45.57	74.00	54.00	-21.13	-8.43
9600.05	V	47.6	36.85	74.00	54.00	-26.4	-17.15
4924.11	H	54.91	47.55	74.00	54.00	-19.09	-6.45
7138.03	H	50.45	43.15	74.00	54.00	-23.55	-10.85
9599.15	H	48.76	37.8	74.00	54.00	-25.24	-16.2

- Note:** (1) All Readings are Peak Value (VBW=3MHz) and Peak Value (VBW=10Hz).  
(2) Emission Level= Reading Level+Probe Factor +Cable Loss.  
(3) Data of measurement within this frequency range shown "--" in the table above means the reading of emissions are attenuated more than 20dB below the permissible limits or the field strength is too small to be measured.

■ Spurious Emission in Restricted Band 2310-2390MHz and 2483.5-2500MHz  
 All modes 2.4G 802.11b/g/n have been tested, and the worst result 802.11n(ht20) recorded was report as below:

Temperature :	26℃	Test Date :	March 02, 2017
Humidity :	60 %	Test By:	King Kong
Test mode:	802.11n(ht20)	Frequency:	Channel 1: 2412MHz

Frequency (MHz)	Polarity	PK(dBuV/m) (VBW=3MHz)	Limit 3m (dBuV/m)	Over(dB)	AV(dBuV/m) (VBW=10Hz)	Limit 3m (dBuV/m)	Over(dB)
2389.92	H	56.28	74.00	-17.72	42.10	54.00	-11.90
2389.84	V	53.65	74.00	-20.35	41.00	54.00	-13.00

Temperature :	26℃	Test Date :	March 02, 2017
Humidity :	60 %	Test By:	King Kong
Test mode:	802.11n(ht20)	Frequency:	Channel 11: 2462MHz

Frequency (MHz)	Polarity	PK(dBuV/m) (VBW=3MHz)	Limit 3m (dBuV/m)	Over(dB)	AV(dBuV/m) (VBW=10Hz)	Limit 3m (dBuV/m)	Over(dB)
2483.50	H	66.13	74.00	-7.87	46.30	54.00	-7.07
2483.50	V	60.87	74.00	-13.13	45.90	54.00	-8.10

**Note:** (1) All Readings are Peak Value (VBW=3MHz) and Peak Value (VBW=10Hz).  
 (2) Emission Level= Reading Level+Probe Factor +Cable Loss.  
 (3) Data of measurement within this frequency range shown "--" in the table above means the reading of emissions are attenuated more than 20dB below the permissible limits or the field strength is too small to be measured.

**Spurious Emission in Restricted Band 2310-2390MHz**

Test Model     802.11b     802.11g     802.11n(HT20)     802.11n(HT40)  
 Channel 1: 2412MHz     Channel 3: 2422MHz    Polarity: H  
 VBW=3MHz    Test By: King Kong

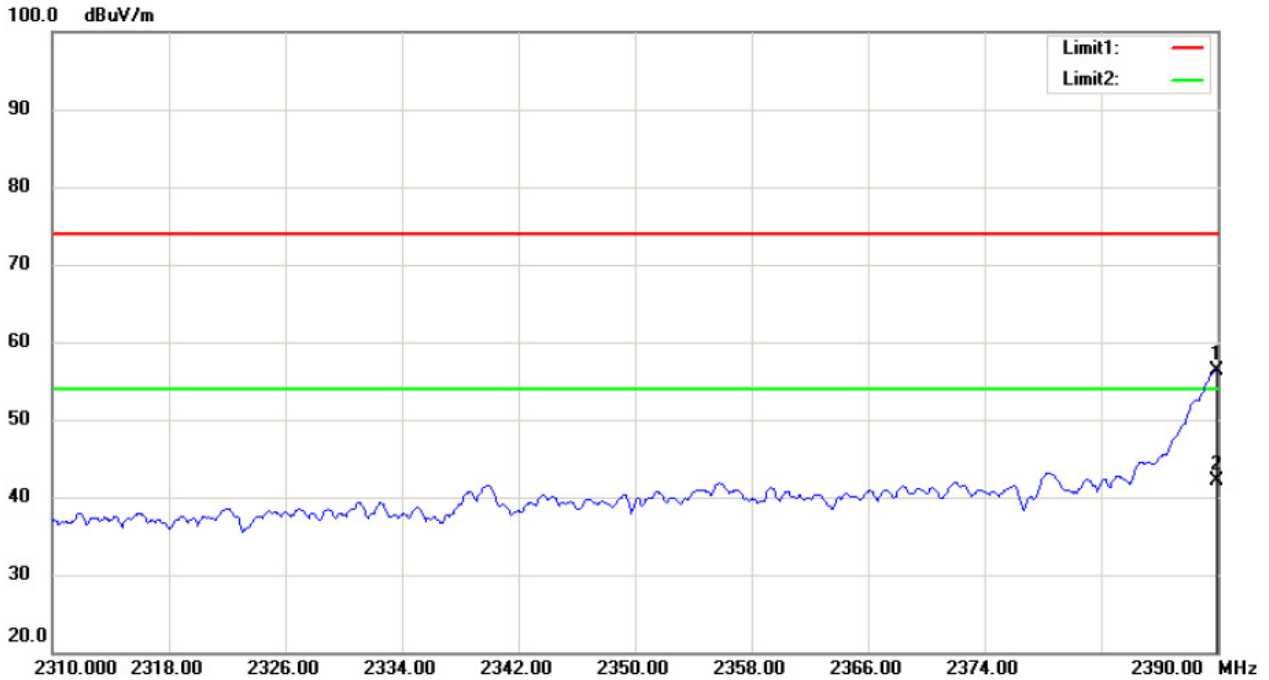

**Spurious Emission in Restricted Band 2310-2390MHz**

Test Model     802.11b     802.11g     802.11n(HT20)     802.11n(HT40)  
 Channel 1: 2412MHz     Channel 3: 2422MHz    Polarity: V  
 VBW=3MHz    Test By: King Kong

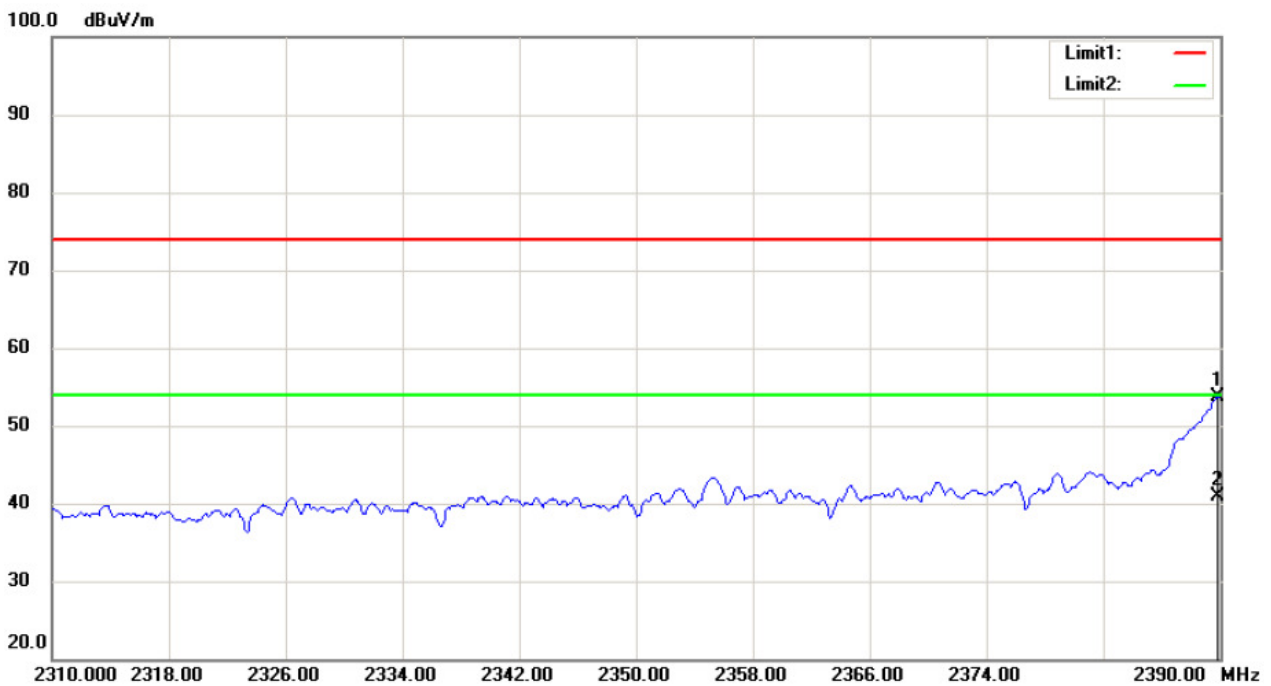



**Spurious Emission in Restricted Band 2483.5-2500MHz**

Test Model	<input type="checkbox"/> 802.11b	<input type="checkbox"/> 802.11g	<input checked="" type="checkbox"/> 802.11n(HT20)	<input type="checkbox"/> 802.11n(HT40)
	<input checked="" type="checkbox"/> Channel 11: 2462MHz	<input type="checkbox"/> Channel 9: 2452MHz		Polarity: H
	VBW=3MHz		Test By: King Kong	

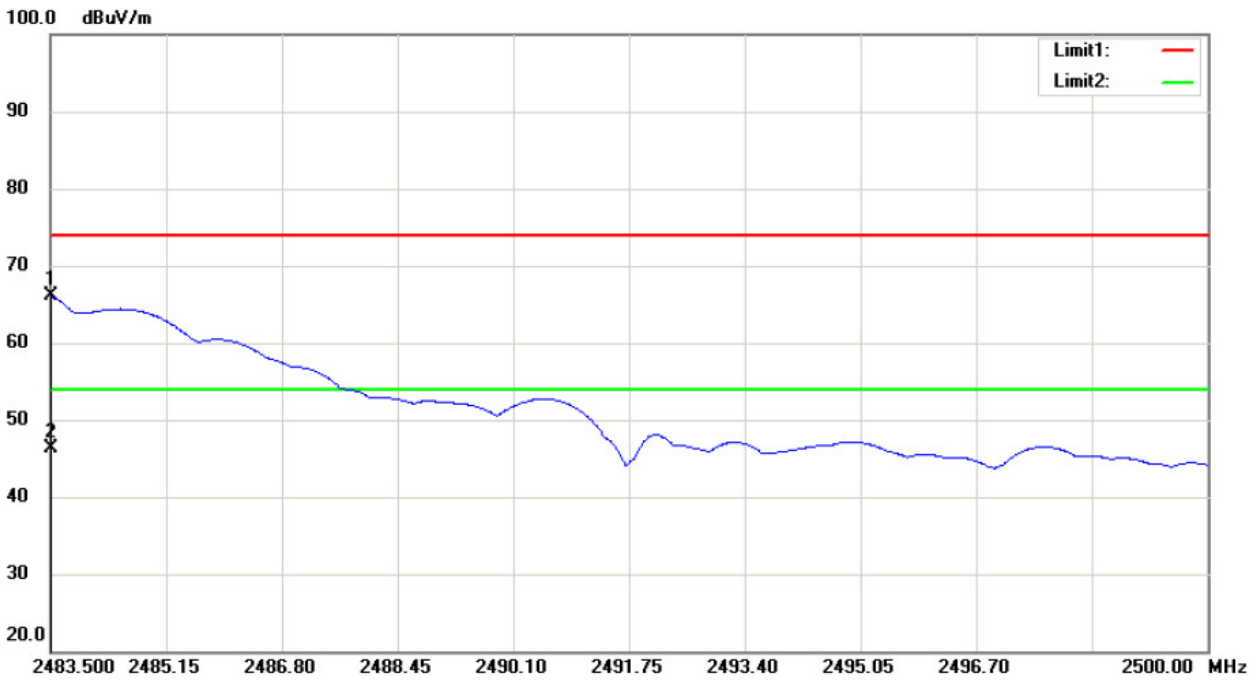

**Spurious Emission in Restricted Band 2483.5-2500MHz**

Test Model	<input type="checkbox"/> 802.11b	<input type="checkbox"/> 802.11g	<input checked="" type="checkbox"/> 802.11n(HT20)	<input type="checkbox"/> 802.11n(HT40)
	<input checked="" type="checkbox"/> Channel 11: 2462MHz	<input type="checkbox"/> Channel 9: 2452MHz		Polarity: V
	VBW=3MHz		Test By: King Kong	

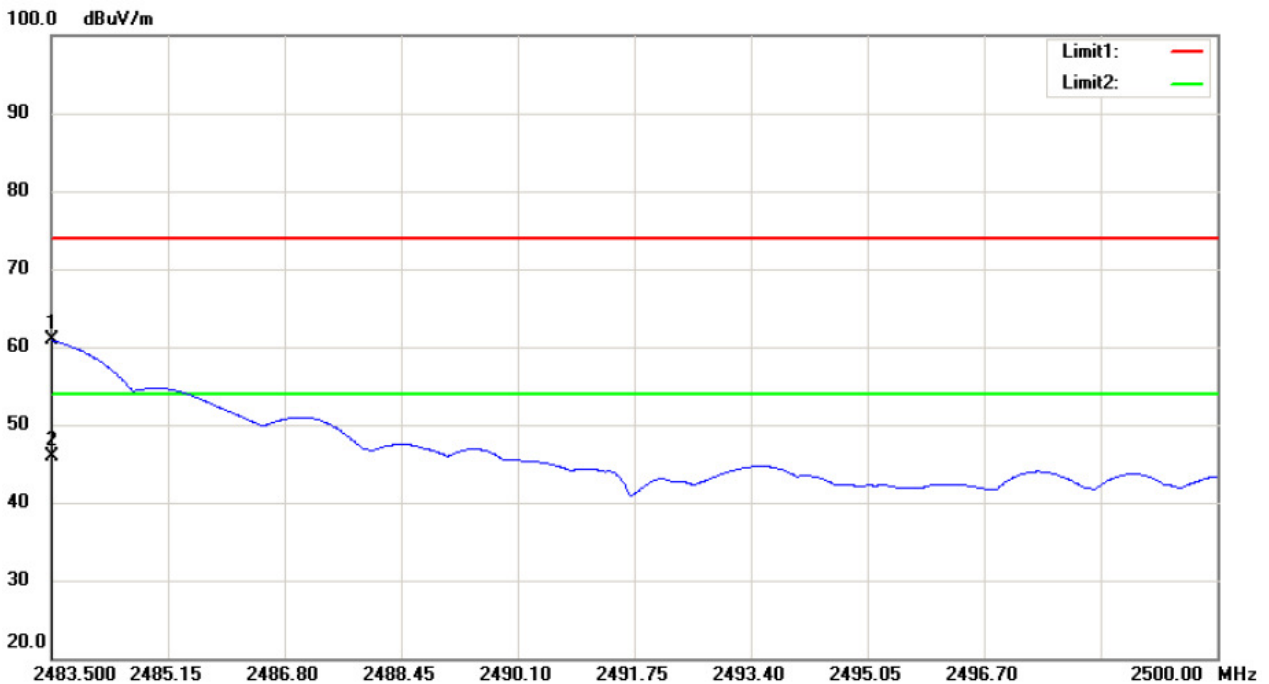



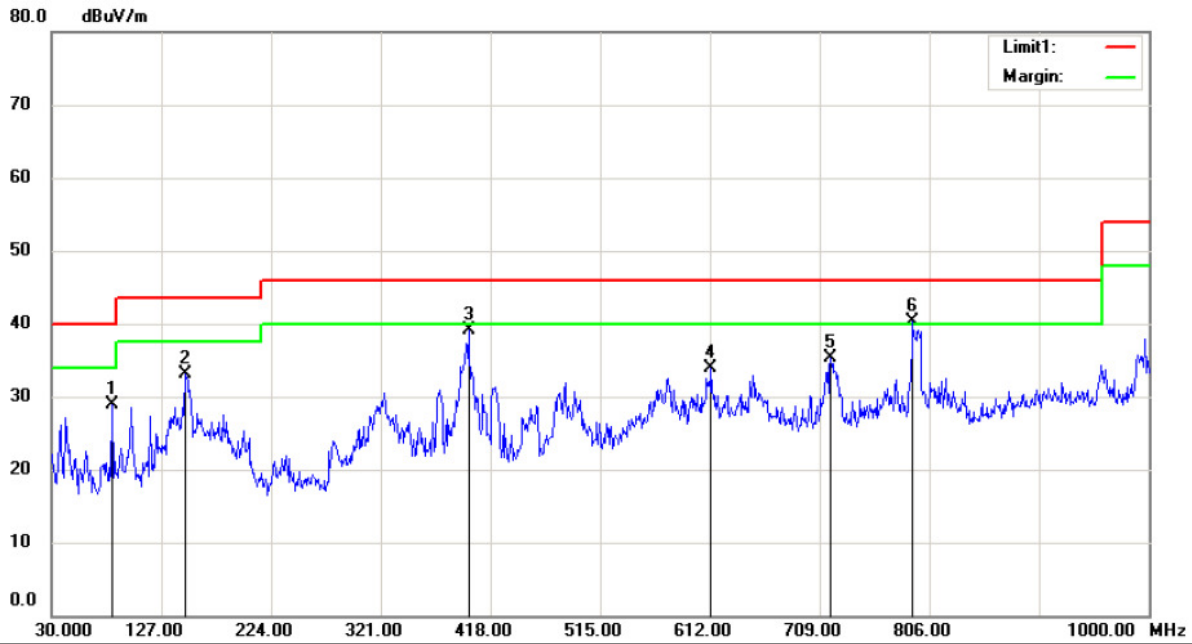

Site 3m Chamber #1 Polarization: **Vertical** Temperature: 22 C  
 Limit: (RE)FCC PART 15 C Power: AC 120V/60Hz Humidity: 50 %  
 Mode:TX 2412  
 Note:

No.	Mk.	Freq.	Reading Level	Correct Factor	Measurement	Limit	Over	Antenna Height	Table Degree	
		MHz	dBuV	dB	dBuV/m	dBuV/m	dB	cm	degree	Comment
1		83.3500	44.14	-15.18	28.96	40.00	-11.04	QP		
2		148.3400	48.84	-15.73	33.11	43.50	-10.39	QP		
3		398.6000	47.67	-8.64	39.03	46.00	-6.97	QP		
4		612.9700	36.48	-2.54	33.94	46.00	-12.06	QP		
5		718.7000	37.50	-2.17	35.33	46.00	-10.67	QP		
6	*	791.4500	40.95	-0.56	40.39	46.00	-5.61	QP		

\*:Maximum data x:Over limit !:over margin

Operator: KK

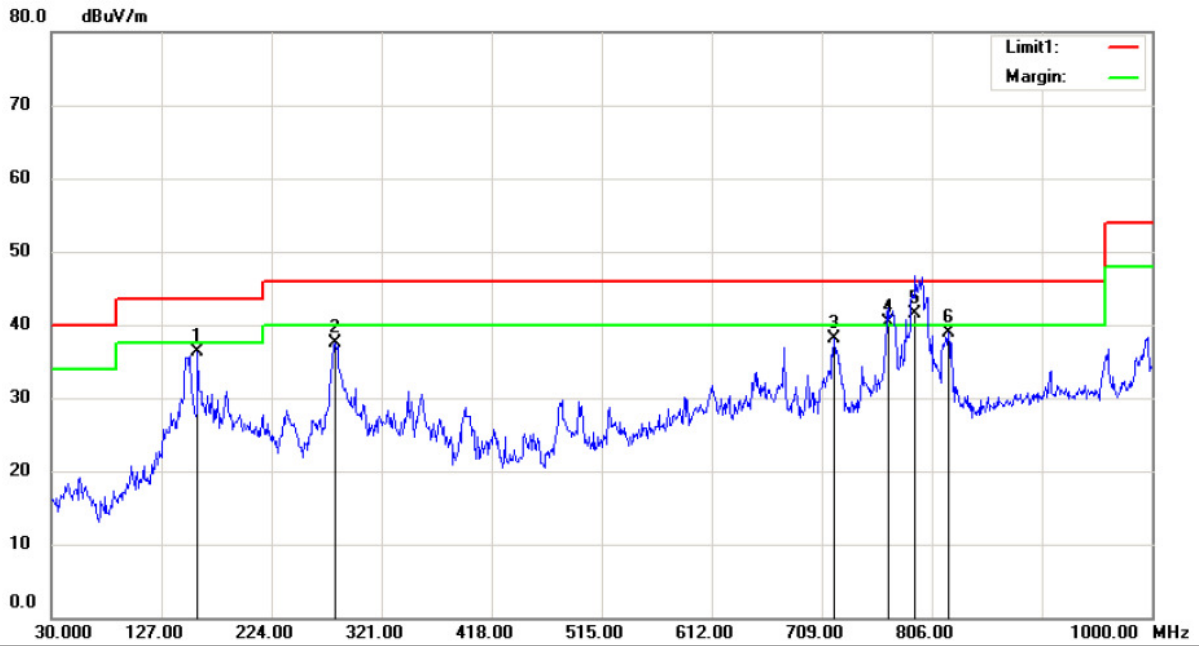

Site 3m Chamber #1      Polarization: **Horizontal**      Temperature: 22 C  
 Limit: (RE)FCC PART 15 C      Power: AC 120V/60Hz      Humidity: 50 %  
 Mode:TX 2437  
 Note:

No.	Mk.	Freq.	Reading Level	Correct Factor	Measurement	Limit	Over	Antenna Height	Table Degree	Comment
		MHz	dBuV	dB	dBuV/m	dBuV/m	dB	cm	degree	
1		159.0100	51.47	-15.22	36.25	43.50	-7.25	QP		
2		280.2600	47.92	-10.48	37.44	46.00	-8.56	QP		
3		719.6700	40.25	-2.20	38.05	46.00	-7.95	QP		
4	!	767.2000	40.62	-0.32	40.30	46.00	-5.70	QP		
5	*	791.4500	42.06	-0.56	41.50	46.00	-4.50	QP		
6		820.5500	39.23	-0.31	38.92	46.00	-7.08	QP		

!:Maximum data    x:Over limit    !:over margin

Operator: KK

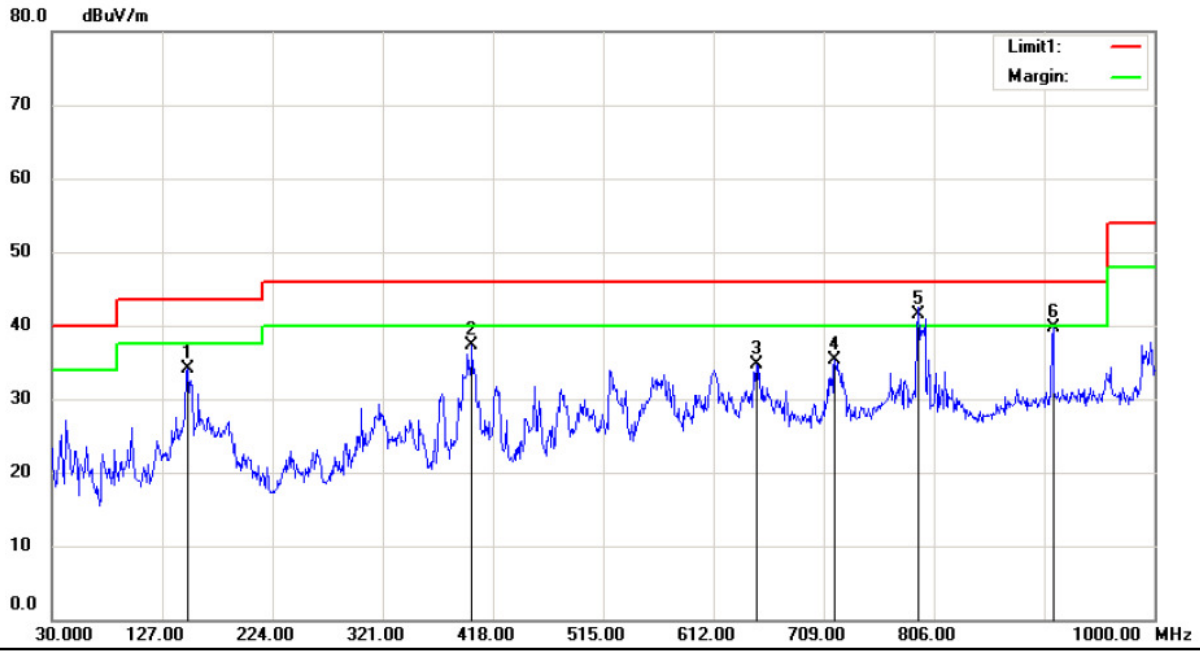

Site 3m Chamber #1      Polarization: **Vertical**      Temperature: 22 C  
 Limit: (RE)FCC PART 15 C      Power: AC 120V/60Hz      Humidity: 50 %  
 Mode:TX 2437  
 Note:

No.	Mk.	Freq.	Reading Level	Correct Factor	Measurement	Limit	Over	Antenna Height	Table Degree	
		MHz	dBuV	dB	dBuV/m	dBuV/m	dB	cm	degree	Comment
1		149.3100	49.77	-15.59	34.18	43.50	-9.32			QP
2		399.5700	46.00	-8.65	37.35	46.00	-8.65			QP
3		649.8300	35.88	-1.12	34.76	46.00	-11.24			QP
4		718.7000	37.57	-2.17	35.40	46.00	-10.60			QP
5	*	792.4200	42.01	-0.51	41.50	46.00	-4.50			QP
6		910.7600	38.01	1.73	39.74	46.00	-6.26			QP

\*:Maximum data    x:Over limit    !:over margin

Operator: KK

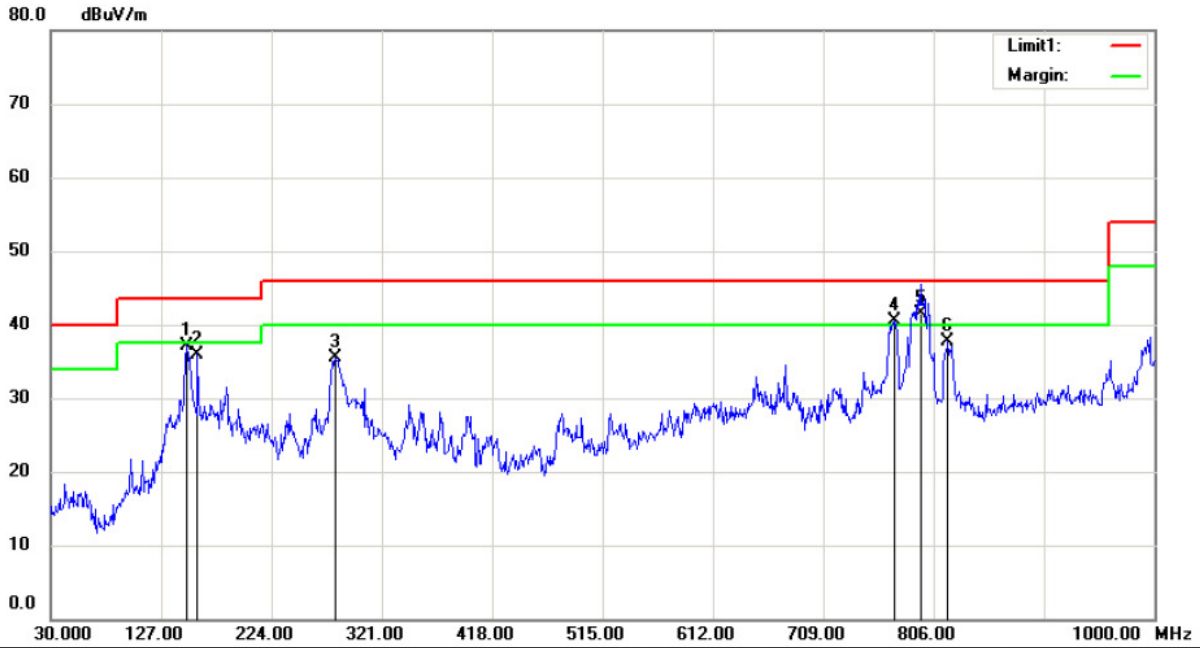

Site 3m Chamber #1

Polarization: **Horizontal**

Temperature: 22 C

Limit: (RE)FCC PART 15 C

Power: AC 120V/60Hz

Humidity: 50 %

Mode:TX 2462

Note:

No.	Mk.	Freq.	Reading Level	Correct Factor	Measurement	Limit	Over	Antenna Height	Table Degree	
		MHz	dBuV	dB	dBuV/m	dBuV/m	dB	cm	degree	Comment
1		149.3100	52.66	-15.59	37.07	43.50	-6.43			QP
2		159.0100	51.13	-15.22	35.91	43.50	-7.59			QP
3		280.2600	45.96	-10.48	35.48	46.00	-10.52			QP
4	!	772.0500	40.68	-0.25	40.43	46.00	-5.57			QP
5	*	794.3600	42.04	-0.44	41.60	46.00	-4.40			QP
6		818.6100	38.05	-0.34	37.71	46.00	-8.29			QP

\*:Maximum data    x:Over limit    !:over margin

Operator: KK

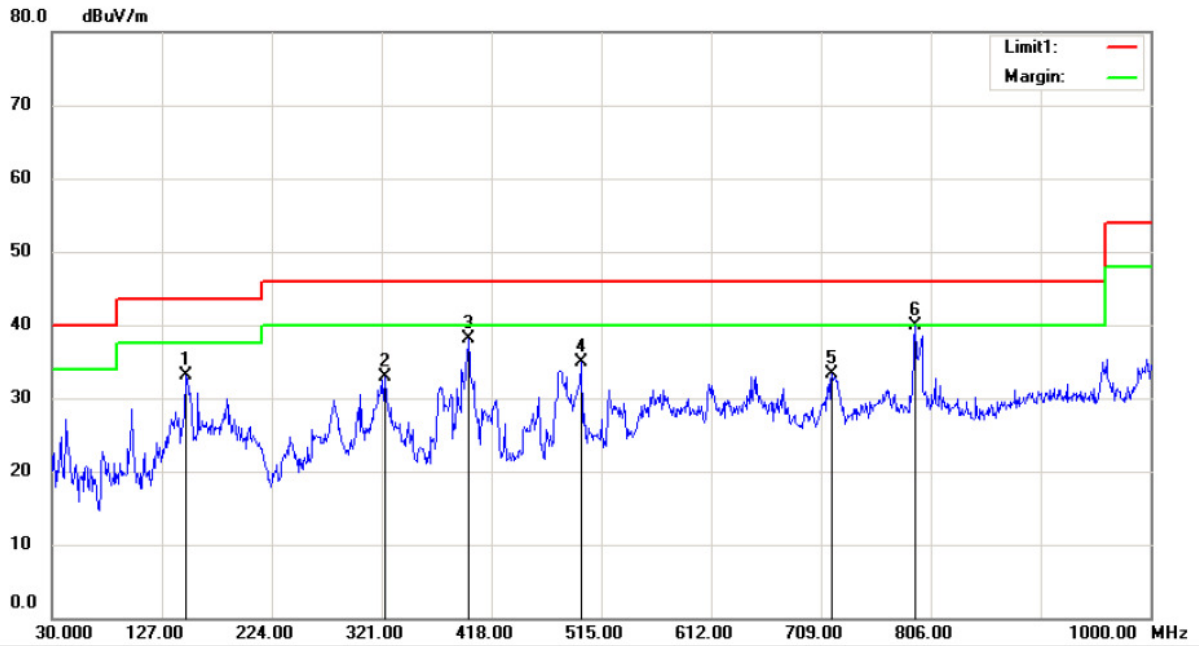

Site 3m Chamber #1      Polarization: **Vertical**      Temperature: 22 C  
 Limit: (RE)FCC PART 15 C      Power: AC 120V/60Hz      Humidity: 50 %  
 Mode:TX 2462  
 Note:

No.	Mk.	Freq.	Reading Level	Correct Factor	Measurement	Limit	Over	Antenna Height	Table Degree	
		MHz	dBuV	dB	dBuV/m	dBuV/m	dB	cm	degree	Comment
1		148.3400	48.74	-15.73	33.01	43.50	-10.49	QP		
2		323.9100	42.82	-9.90	32.92	46.00	-13.08	QP		
3		397.6300	46.80	-8.62	38.18	46.00	-7.82	QP		
4		497.5400	41.02	-6.10	34.92	46.00	-11.08	QP		
5		718.7000	35.42	-2.17	33.25	46.00	-12.75	QP		
6	*	792.4200	40.43	-0.51	39.92	46.00	-6.08	QP		

\*:Maximum data    x:Over limit    !:over margin

Operator: KK

-----The end-----