

Application for FCC Certificate
On Behalf of
Hisense Electric Co., Ltd.

LED LCD TV

Model No.	Brand
RLDED3279A	RCA
32H5C, 32H5C+, 32H5B, 32H5B+	Hisense

FCC ID : W9HLCDC0038

Prepared For : Hisense Electric Co., Ltd.
No.218 Qianwangang Road, Economy & Technology
Development Zone, Qingdao, China

Prepared By : Audix Technology (Shanghai) Co., Ltd.
3F and 4F, 34Bldg 680 Guiping Rd,
Caohejing Hi-Tech Park,
Shanghai 200233, China

Tel: +86-21-64955500

Fax: +86-21-64955491

Report No. : ACI-F16180
Date of Test : Jul 08 – 20, 2016
Date of Report : Jul 28, 2016

TABLE OF CONTENTS

	Page
1 SUMMARY OF STANDARDS AND RESULTS	4
1.1 Description of Standards and Results.....	4
2 GENERAL INFORMATION	5
2.1 Description of Equipment Under Test.....	5
2.2 Peripherals.....	6
2.3 Description of Test Facility.....	7
2.4 Measurement Uncertainty.....	8
3 CONDUCTED EMISSION TEST	9
3.1 Test Equipment.....	9
3.2 Block Diagram of Test Setup.....	9
3.3 Conducted Emission Limit [FCC Part 15 Subpart B 15.107(a)].....	10
3.4 Test Configuration.....	10
3.5 Operating Condition of EUT.....	11
3.6 Test Procedures.....	11
3.7 Test Results.....	12
4 RADIATED EMISSION TEST	19
4.1 Test Equipment.....	19
4.2 Block Diagram of Test Setup.....	19
4.3 Radiated Emission Limit [FCC Part 15 Subpart B 15.109(a)].....	21
4.4 Test Configuration.....	21
4.5 Operating Condition of EUT.....	21
4.6 Test Procedures.....	21
4.7 Test Results.....	22
5 DEBUG DESCRIPTION	30
6 DEVIATION TO TEST SPECIFICATIONS	31

TEST REPORT FOR FCC CERTIFICATE

Applicant : Hisense Electric Co., Ltd.
 Manufacturer : Hisense Electric Co., Ltd.
 Factory #1 : Hisense Electric Co., Ltd.
 Factory #2 : Tatung Mexico S.A. de C.V.
 Factory #3 : HISENSE ELECTRONICA MEXICO, S.A. DE C.V.
 EUT Description : LED LCD TV

Model No.	Brand	Power Supply
RLDED3279A	RCA	120V/60Hz
32H5C, 32H5C+, 32H5B, 32H5B+	Hisense	

Test Procedure Used:

*FCC RULES AND REGULATIONS PART 15 SUBPART B CLASS B OCTOBER 2015
AND ANSI C63.4-2014*

The device described above is tested by Audix Technology (Shanghai) Co., Ltd. To determine the maximum emission levels emanating from the device. The maximum emission levels are compared to the FCC Part 15 Subpart B (Class B) limits both radiated and conducted emissions.

The test results are contained in this test report and Audix Technology (Shanghai) Co., Ltd. is assumed full responsibility for the accuracy and completeness of these measurements. This report shows that the EUT (M/N: Refer to Sec2.1) which was tested in 3m anechoic chamber Jul 08 – 20, 2016 is technically compliance with the FCC official limits also.

This report applies to above tested sample only. This report shall not be reproduced in part without written approval of Audix Technology (Shanghai) Co., Ltd.

This report contains data that are not covered by the NVLAP accreditation.

This report must not be used by the client to claim product certification, approval, or endorsement by NVLAP, NIST, or any agency of the federal government.

The test results for EUT's TV functions are contained in No.F16181, a Verification report.

Date of Test : Jul 08 – 20, 2016 Date of Report : Jul 28, 2016

Producer : 
 TINA LIANG / Assistant

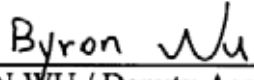
Review: 
 BYRON WU / Deputy Assistant Manager

 For and on behalf of
 Audix Technology (Shanghai) Co., Ltd.

Signatory: 
 Authorized Signature EMC SAMMY CHEN / Manager

1 SUMMARY OF STANDARDS AND RESULTS

1.1 Description of Standards and Results

The EUT have been tested according to the applicable standards as referenced below:

Description of Test Item	Standard	Limits	Results
EMISSION			
Conducted Disturbance at the Mains Terminal	FCC RULES AND REGULATIONS PART 15 SUBPART B OCTOBER 2015 AND ANSI C63.4-2014	15.107(a) Class B	Pass
Radiated Disturbance	FCC RULES AND REGULATIONS PART 15 SUBPART B OCTOBER 2015 AND ANSI C63.4-2014	15.109(a) Class B	Pass

2 GENERAL INFORMATION

2.1 Description of Equipment Under Test

Description : LED LCD TV

Type of EUT : Production Pre-product Pro-type

Model No.	Brand
RLDED3279A	RCA
32H5C, 32H5C+, 32H5B, 32H5B+	Hisense

Note #1 : The above models are all the same except for the model number and brand. The 32H5C was tested and recorded in the report.

Note#2 : “+ ” represents any numerals, for different sales area

Applicant : Hisense Electric Co., Ltd.
No.218 Qianwangang Road, Economy &
Technology Development Zone, Qingdao, China

Manufacturer : Same as Applicant

Factory #1 : Same as Applicant

Factory #2 : Tatung Mexico S.A. de C.V.
Miguel Catalán 420, Parque Industrial Rio Bravo,
Cd. Juarez, Chih., CP 32557

Factory #3 : HISENSE ELECTRONICA MEXICO,S.A. DE C.V.
Blvd. Sharp #3510 Parque Industrial
Rosarito, C.P. 22710 Playas de Rosarito, B.C.

LCD Panel : Manufacturer : Hisense
M/N : HD315DH-B12(110)

Tuner : Manufacturer : XuGuang Tech. Co., Ltd.
M/N : HFT-96S3/W11FJ4H/ROH

Max Resolution : 1366*768@60Hz

HDMI Cable*2 : Shielded, Detachable, 1.50m
(Lab provide)

Power Cord : Unshielded, Detachable, 1.80m, 2C

USB Cable : Shielded, Detachable, 1.00m
(Lab provide)

LAN Cable : Unshielded, Detachable, 1.50m

Remark:

The EUT is a LED LCD TV which input/output ports as follows:

Side Port:

- (1) One Service Port : Do not open to the customers
- (2) One LAN Port : Connected with PC
- (3) One USB Port : Connected with Hard-Disk
- (4) One DIGITAL AUDIO OUT Port : Connected with Audio Converter to Earphone #2

Bottom Port:

- (5) One ANT Port : Connected with ATSC SG/TV SG
- (6) One AUDIO OUT Port : Connected with Earphone #1
- (7) One HDMI1 Port : Connected with DVD PLAYER
- (8) One HDMI2 Port : Connected with PC
- (9) One AV IN Port : Connected with DVD PLAYER
- (10) One COMPONENT IN Port : Connected with DVD PLAYER

2.2 Peripherals

2.2.1 PC

Manufacturer : HP
 Model Number : DX7400MT
 Serial Number : CNG8130K89
 Power Cord : Unshielded, Detachable, 1.8m
 Certificate : CE/EMC, FCC DoC, VCCI, UL, CCC

2.2.2 Keyboard

Manufacturer : Microsoft
 Model Number : RT2300
 Serial Number : 7668200662248
 Data Cable : Shielded, Detachable, 1.5m
 Certificate : CE/EMC, FCC DoC, VCCI, MIC, C-Tick, BSMI

2.2.3 Mouse

Manufacturer : Microsoft
 Model Number : RT2300
 Serial Number : 6965712071551
 Data Cable : Shielded, Detachable, 1.5m.
 Certificate : CE/EMC, FCC DoC, VCCI, MIC, C-Tick, BSMI

2.2.4 Earphone *2

Manufacturer : EDIFIER
Model Number : H210

2.2.5 DVD PLAYER

Manufacturer : PHILIPS
Model Number : DVP3986K/93
Serial Number : KX1A0902120108
Certificate : CCC

2.2.6 Hard Disk

Manufacturer : Tetasys
Model Number : F12
Serial Number : A010022-486006
Data Cable : Shielded, Undetachable, 1.8m.
Certificate : CE, FCC DoC

2.2.7 ATSC Signal Generator

Manufacturer : SENCORE
Model Number : ATSC997
Serial Number : 6790071

2.2.8 TV Signal Generator

Manufacturer : FLUKE
Model Number : 54200M01
Serial Number : 814008

2.3 Description of Test Facility

Site Description (No.3 3m Chamber) : Sept. 17, 1998 file on
Jan.15, 2015 Renewed
Federal Communications Commission
FCC Engineering Laboratory
7435 Oakland Mills Road
Columbia, MD 21046, USA

Name of Firm : Audix Technology (Shanghai) Co., Ltd.

Site Location : 3F 34Bldg 680 Guiping Rd,
Caohejing Hi-Tech Park,
Shanghai 200233, China

FCC registration Number : 91789

NVLAP Lab Code : 200371-0

2.4 Measurement Uncertainty

Conducted Emission Expanded Uncertainty : U = 3.4dB

Radiated Emission Expanded Uncertainty (30-200MHz):

U = 4.6dB(Horizontal)

U = 4.3dB (Vertical)

Radiated Emission Expanded Uncertainty (200M-1GHz):

U = 4.5dB (Horizontal)

U = 5.4dB (Vertical)

Radiated Emission Expanded Uncertainty (1GHz-6GHz):

U = 5.1dB

3 CONDUCTED EMISSION TEST

3.1 Test Equipment

The following test equipments are used during the conducted emission test in a shielded room:

Item	Type	Manufacturer	Model No.	Serial No.	Last Cal.	Next Cal.
1.	Test Receiver	R&S	ESCI	101302	Apr 27, 2016	Apr 26, 2017
2.	Artificial Mains Network (AMN)	R&S	ENV4200	100125	Jun 25, 2016	Jun 24, 2017
3.	Line Impedance Stabilization Network (LISN)	Kyoritsu	KNW-407	8-1280-4	Mar 20, 2016	Mar 19, 2017
4.	50Ω Terminator	Anritsu	BNC	001	Mar 20, 2016	Mar 19, 2017
5.	Software	Audix	e3	6.111206	--	--

3.2 Block Diagram of Test Setup

3.2.1 EUT & Peripherals

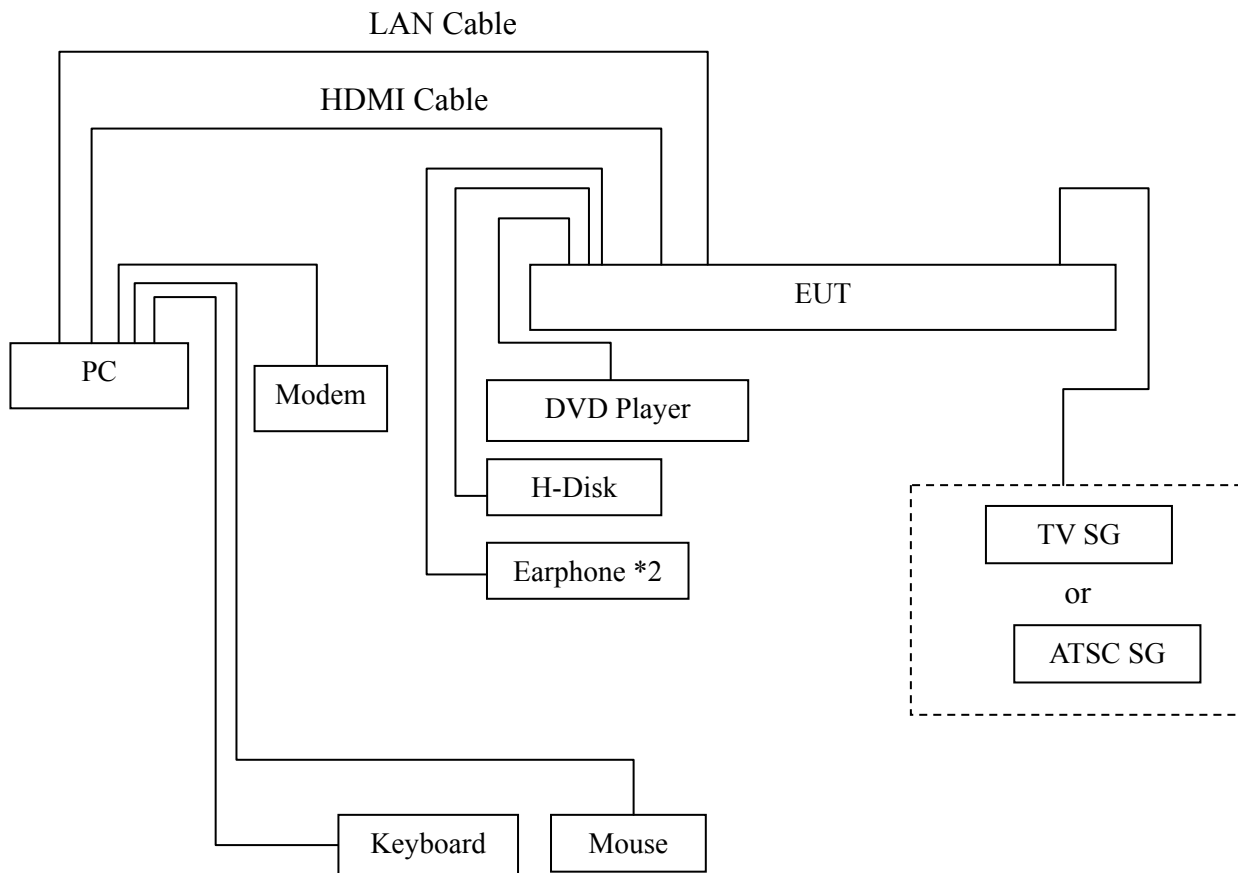

3.2.2 Conducted Disturbance Test Setup

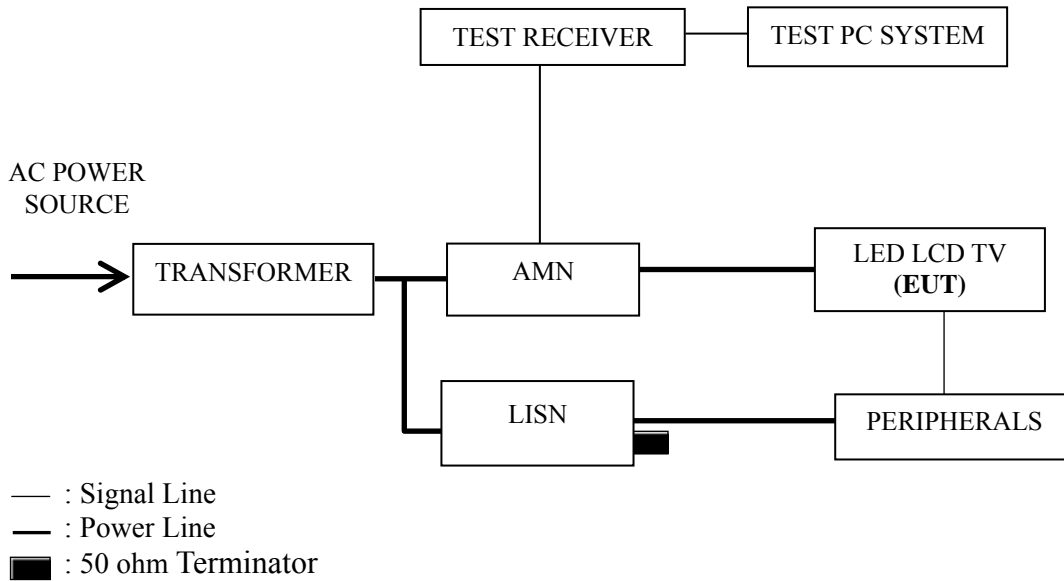

3.3 Conducted Emission Limit [FCC Part 15 Subpart B 15.107(a)]

Frequency Range (MHz)	Limits dB (μ V)	
	Quasi-peak	Average
0.15 ~ 0.5	66~56	56~46
0.5 ~ 5	56	46
5 ~ 30	60	50

NOTE 1 – The lower limit shall apply at the transition frequencies.
 NOTE 2 – The limit decreases linearly with the logarithm of the frequency in the range 0.15 MHz~0.50 MHz

3.4 Test Configuration

The EUT (listed in Sec.2.1) and the peripherals (listed in Sec 2.2) were installed as shown on Sec.3.2 to meet FCC requirement and operating in a manner that tends to maximize its emission level in a normal application.

3.5 Operating Condition of EUT

- 3.5.1 Setup the EUT and peripherals as shown in Sec. 3.2.
- 3.5.2 Turn on the power of all equipments and the EUT.
- 3.5.3 Set the contrast & brightness of EUT to maximum.
- 3.5.4 PC system ran the self-test program “EMC Test” by windows XP and sent “H” characters to EUT through graphic card, the EUT’s screen displayed and filled with “H” pattern by its resolution (Via HDMI Input).
- 3.5.5 PC system sent the 1kHz audio signal to EUT through audio port, the EUT speak out 1kHz audio signal.
- 3.5.6 In USB Play mode, set the EUT play digital media from H-Disk.
- 3.5.7 In LAN Play mode, set the EUT play digital media through LAN port.
- 3.5.8 The other peripherals devices were driven and operated during the test.
- 3.5.9 The test modes are as follows:

Test Mode
HDMI 1024*768@60Hz & 1kHz Playing
HDMI 800*600@60Hz & 1kHz Playing
HDMI 640*480@60Hz & 1kHz playing
HDMI1080P
USB Play
LAN Play

3.6 Test Procedures

The EUT and peripherals were connected to the power mains through an Artificial Mains Network (AMN). This provided a 50 ohm coupling impedance for the measuring equipment.

Both sides of AC line (Line & Neutral) were checked for maximum conducted interference. In order to find the maximum emission, the relative positions of equipment and all of the interface cables were changed or manipulated according to ANSI C63.4:2014 during conducted emission test.

The bandwidth of R&S Test Receiver ESCI was set at 9 kHz.

The frequency range from 150 kHz to 30 MHz was checked.

The test modes were done on conducted disturbance test and all the test results are listed in Sec. 3.7.

3.7 Test Results

< **PASS** >

The frequency and amplitude of the highest conducted emission relative to the limit is reported. All emissions not reported below are too low against the prescribed limits.

Test Mode	Data Page
HDMI 1024*768@60Hz & 1kHz Playing	P13
HDMI 800*600@60Hz & 1kHz Playing	P14
HDMI 640*480@60Hz & 1kHz playing	P15
HDMI1080P	P16
USB Play	P17
LAN Play	P18

NOTE 1 – Factor = Cable Loss + AMN Factor.

NOTE 2 – Emission Level = Meter Reading + Factor.

NOTE 3 – “QP” means “Quasi-Peak” values, “AV” means “Average” values.

NOTE 4 – The worst case is for LAN Play test mode. The worst emission is detected at 0.221MHz (Quasi-Peak Value) with corrected signal level of 51.10 dB (μ V) (limit is 62.78 dB (μ V)), when the Neutral of the EUT is connected to AMN.

EUT : LED LCD TV Temperature : 22

Model No. : 32H5C Humidity : 48%RH

Test Mode : HDMI 1024*768@60Hz Date of Test : Jul 08, 2016
& 1kHz Playing

Test Line	Frequency (MHz)	Meter Reading dB(μ V)	Factor (dB)	Emission Level dB(μ V)	Limits dB(μ V)	Margin (dB)	Remark
Line	0.191	30.60	10.54	41.14	64.00	22.86	QP
	0.414	33.50	10.43	43.93	57.56	13.63	
	0.870	28.80	10.40	39.20	56.00	16.80	
	1.600	27.91	10.40	38.31	56.00	17.69	
	4.042	27.50	10.44	37.94	56.00	18.06	
	6.879	28.80	10.47	39.27	60.00	20.73	
	AV	0.191	17.70	10.54	28.24	54.00	25.76
		0.414	24.60	10.43	35.03	47.56	12.53
		0.870	18.30	10.40	28.70	46.00	17.30
		1.600	18.21	10.40	28.61	46.00	17.39
		4.042	20.70	10.44	31.14	46.00	14.86
		6.879	21.50	10.47	31.97	50.00	18.03
Neutral	0.186	29.90	10.54	40.44	64.22	23.78	QP
	0.410	33.10	10.42	43.52	57.65	14.13	
	0.653	26.70	10.39	37.09	56.00	18.91	
	1.864	21.80	10.43	32.23	56.00	23.77	
	4.369	20.70	10.49	31.19	56.00	24.81	
	9.769	21.80	10.57	32.37	60.00	27.63	
	AV	0.186	16.50	10.54	27.04	54.22	27.18
		0.410	24.50	10.42	34.92	47.65	12.73
		0.653	11.60	10.39	21.99	46.00	24.01
		1.864	13.90	10.43	24.33	46.00	21.67
		4.369	13.20	10.49	23.69	46.00	22.31
		9.769	14.90	10.57	25.47	50.00	24.53

TEST ENGINEER: SEVEN LU

EUT : LED LCD TV Temperature : 22

Model No. : 32H5C Humidity : 48%RH

Test Mode : HDMI 800*600@60Hz & 1kHz Playing Date of Test : Jul 08, 2016

Test Line	Frequency (MHz)	Meter Reading dB(μ V)	Factor (dB)	Emission Level dB(μ V)	Limits dB(μ V)	Margin (dB)	Remark
Line	0.153	32.40	10.59	42.99	65.86	22.87	QP
	0.416	33.90	10.43	44.33	57.54	13.21	
	0.871	28.80	10.40	39.20	56.00	16.80	
	1.603	28.01	10.40	38.41	56.00	17.59	
	4.063	26.70	10.44	37.14	56.00	18.86	
	5.914	28.50	10.46	38.96	60.00	21.04	AV
	0.153	18.50	10.59	29.09	55.86	26.77	
	0.416	25.20	10.43	35.63	47.54	11.91	
	0.871	18.30	10.40	28.70	46.00	17.30	
	1.603	18.31	10.40	28.71	46.00	17.29	
Neutral	4.063	20.40	10.44	30.84	46.00	15.16	QP
	5.914	21.60	10.46	32.06	50.00	17.94	
	0.190	32.70	10.53	43.23	64.05	20.82	
	0.407	33.10	10.42	43.52	57.71	14.19	
	0.653	26.60	10.39	36.99	56.00	19.01	
	1.604	22.50	10.42	32.92	56.00	23.08	AV
	4.004	21.89	10.49	32.38	56.00	23.62	
	9.877	22.50	10.57	33.07	60.00	26.93	
	0.190	18.20	10.53	28.73	54.05	25.32	
	0.407	24.50	10.42	34.92	47.71	12.79	
0.653	11.70	10.39	22.09	46.00	23.91	AV	
1.604	13.30	10.42	23.72	46.00	22.28		
4.004	14.09	10.49	24.58	46.00	21.42		
	9.877	15.20	10.57	25.77	50.00	24.23	

TEST ENGINEER: SEVEN LU

EUT : LED LCD TV Temperature : 22

Model No. : 32H5C Humidity : 48%RH

Test Mode : HDMI 640*480@60Hz & 1kHz playing Date of Test : Jul 08, 2016

Test Line	Frequency (MHz)	Meter Reading dB(μ V)	Factor (dB)	Emission Level dB(μ V)	Limits dB(μ V)	Margin (dB)	Remark
Line	0.186	28.70	10.55	39.25	64.23	24.98	QP
	0.415	33.80	10.43	44.23	57.56	13.33	
	0.867	28.00	10.40	38.40	56.00	17.60	
	2.080	26.00	10.41	36.41	56.00	19.59	
	4.330	27.60	10.44	38.04	56.00	17.96	
	6.172	28.50	10.46	38.96	60.00	21.04	
	AV	0.186	17.30	10.55	27.85	54.23	26.38
		0.415	24.90	10.43	35.33	47.56	12.23
		0.867	18.20	10.40	28.60	46.00	17.40
		2.080	18.90	10.41	29.31	46.00	16.69
		4.330	21.00	10.44	31.44	46.00	14.56
		6.172	21.40	10.46	31.86	50.00	18.14
Neutral	0.182	27.80	10.54	38.34	64.40	26.06	QP
	0.404	32.90	10.42	43.32	57.77	14.45	
	0.641	26.10	10.39	36.49	56.00	19.51	
	1.600	22.50	10.42	32.92	56.00	23.08	
	3.897	21.50	10.48	31.98	56.00	24.02	
	9.956	22.70	10.57	33.27	60.00	26.73	
	AV	0.182	15.30	10.54	25.84	54.40	28.56
		0.404	24.50	10.42	34.92	47.77	12.85
		0.641	11.90	10.39	22.29	46.00	23.71
		1.600	13.30	10.42	23.72	46.00	22.28
		3.897	14.10	10.48	24.58	46.00	21.42
		9.956	15.20	10.57	25.77	50.00	24.23

TEST ENGINEER: SEVEN LU

EUT : LED LCD TV Temperature : 22

Model No. : 32H5C Humidity : 48%RH

Test Mode : HDMI1080P Date of Test : Jul 08, 2016

Test Line	Frequency (MHz)	Meter Reading dB(μ V)	Factor (dB)	Emission Level dB(μ V)	Limits dB(μ V)	Margin (dB)	Remark
Line	0.192	32.30	10.54	42.84	63.97	21.13	QP
	0.419	33.49	10.43	43.92	57.48	13.56	
	0.871	28.60	10.40	39.00	56.00	17.00	
	2.374	25.60	10.42	36.02	56.00	19.98	
	4.910	28.80	10.45	39.25	56.00	16.75	
	6.743	28.60	10.47	39.07	60.00	20.93	
	AV	0.192	18.40	10.54	28.94	53.97	25.03
		0.419	24.39	10.43	34.82	47.48	12.66
		0.871	18.30	10.40	28.70	46.00	17.30
		2.374	19.10	10.42	29.52	46.00	16.48
		4.910	21.90	10.45	32.35	46.00	13.65
		6.743	21.70	10.47	32.17	50.00	17.83
Neutral	0.154	29.60	10.57	40.17	65.80	25.63	QP
	0.420	32.99	10.42	43.41	57.44	14.03	
	0.649	26.00	10.39	36.39	56.00	19.61	
	1.876	22.60	10.43	33.03	56.00	22.97	
	3.916	21.20	10.48	31.68	56.00	24.32	
	10.230	22.70	10.57	33.27	60.00	26.73	
	AV	0.154	15.50	10.57	26.07	55.80	29.73
		0.420	24.59	10.42	35.01	47.44	12.43
		0.649	11.60	10.39	21.99	46.00	24.01
		1.876	14.20	10.43	24.63	46.00	21.37
		3.916	14.10	10.48	24.58	46.00	21.42
		10.230	14.20	10.57	24.77	50.00	25.23

TEST ENGINEER: SEVEN LU

EUT : LED LCD TV Temperature : 22

Model No. : 32H5C Humidity : 48%RH

Test Mode : USB Play Date of Test : Jul 08, 2016

Test Line	Frequency (MHz)	Meter Reading dB(μ V)	Factor (dB)	Emission Level dB(μ V)	Limits dB(μ V)	Margin (dB)	Remark
Line	0.196	30.29	10.54	40.83	63.80	22.97	QP
	0.417	33.60	10.43	44.03	57.51	13.48	
	0.871	28.80	10.40	39.20	56.00	16.80	
	2.129	25.90	10.41	36.31	56.00	19.69	
	4.042	27.60	10.44	38.04	56.00	17.96	
	6.714	27.90	10.47	38.37	60.00	21.63	
	0.196	17.99	10.54	28.53	53.80	25.27	AV
	0.417	24.50	10.43	34.93	47.51	12.58	
	0.871	18.40	10.40	28.80	46.00	17.20	
	2.129	19.30	10.41	29.71	46.00	16.29	
	4.042	20.50	10.44	30.94	46.00	15.06	
	6.714	21.50	10.47	31.97	50.00	18.03	
Neutral	0.152	30.10	10.58	40.68	65.87	25.19	QP
	0.421	33.19	10.42	43.61	57.44	13.83	
	0.652	26.40	10.39	36.79	56.00	19.21	
	1.932	21.00	10.43	31.43	56.00	24.57	
	4.475	20.10	10.49	30.59	56.00	25.41	
	9.846	22.50	10.57	33.07	60.00	26.93	
	0.152	16.60	10.58	27.18	55.87	28.69	AV
	0.421	25.09	10.42	35.51	47.44	11.93	
	0.652	11.80	10.39	22.19	46.00	23.81	
	1.932	14.10	10.43	24.53	46.00	21.47	
	4.475	13.40	10.49	23.89	46.00	22.11	
	9.846	15.10	10.57	25.67	50.00	24.33	

TEST ENGINEER: SEVEN LU

EUT : LED LCD TV Temperature : 22

Model No. : 32H5C Humidity : 48%RH

Test Mode : LAN Play Date of Test : Jul 08, 2016

Test Line	Frequency (MHz)	Meter Reading dB(μ V)	Factor (dB)	Emission Level dB(μ V)	Limits dB(μ V)	Margin (dB)	Remark
Line	0.158	31.50	10.58	42.08	65.57	23.49	QP
	0.408	33.50	10.43	43.93	57.70	13.77	
	0.872	29.30	10.40	39.70	56.00	16.30	
	1.808	27.20	10.41	37.61	56.00	18.39	
	4.334	27.70	10.44	38.14	56.00	17.86	
	6.798	29.10	10.47	39.57	60.00	20.43	
	0.158	15.80	10.58	26.38	55.57	29.19	AV
	0.408	24.60	10.43	35.03	47.70	12.67	
	0.872	18.40	10.40	28.80	46.00	17.20	
	1.808	19.30	10.41	29.71	46.00	16.29	
	4.334	21.00	10.44	31.44	46.00	14.56	
	6.798	21.60	10.47	32.07	50.00	17.93	
Neutral	0.189	30.80	10.53	41.33	64.07	22.74	QP
	0.408	33.20	10.42	43.62	57.70	14.08	
	0.643	25.70	10.39	36.09	56.00	19.91	
	1.879	22.50	10.43	32.93	56.00	23.07	
	4.332	20.30	10.49	30.79	56.00	25.21	
	9.767	22.30	10.57	32.87	60.00	27.13	
	0.189	17.40	10.53	27.93	54.07	26.14	AV
	0.408	24.30	10.42	34.72	47.70	12.98	
	0.643	11.80	10.39	22.19	46.00	23.81	
	1.879	14.20	10.43	24.63	46.00	21.37	
	4.332	13.10	10.49	23.59	46.00	22.41	
	9.767	14.40	10.57	24.97	50.00	25.03	

TEST ENGINEER: SEVEN LU

4 RADIATED EMISSION TEST

4.1 Test Equipment

The following test equipments are used during the radiated emission test in a semi-anechoic chamber:

Item	Type	Manufacturer	Model No.	Serial No.	Last Cal.	Next Cal.
1.	Test Receiver	R&S	ESCI	101303	May 07, 2016	May 06, 2017
2.	Preamplifier	Agilent	8447D	2944A06664	Apr 27, 2016	Apr 26, 2017
3.	Preamplifier	HP	8449B	3008A00864	Mar 20, 2016	Sep 19, 2017
4.	Bi-log Antenna	TESEQ	CBL6112D	23193	May 10, 2016	May 09, 2017
5.	Horn Antenna	EMCO	3115	9607-4878	May 31, 2016	May 30, 2017
6.	Spectrum	Agilent	E7405A	MY45106600	Feb 26, 2016	Feb 25, 2017
7.	Software	Audix	e3	6.2007-9-10	--	--

4.2 Block Diagram of Test Setup

4.2.1 EUT & Peripherals

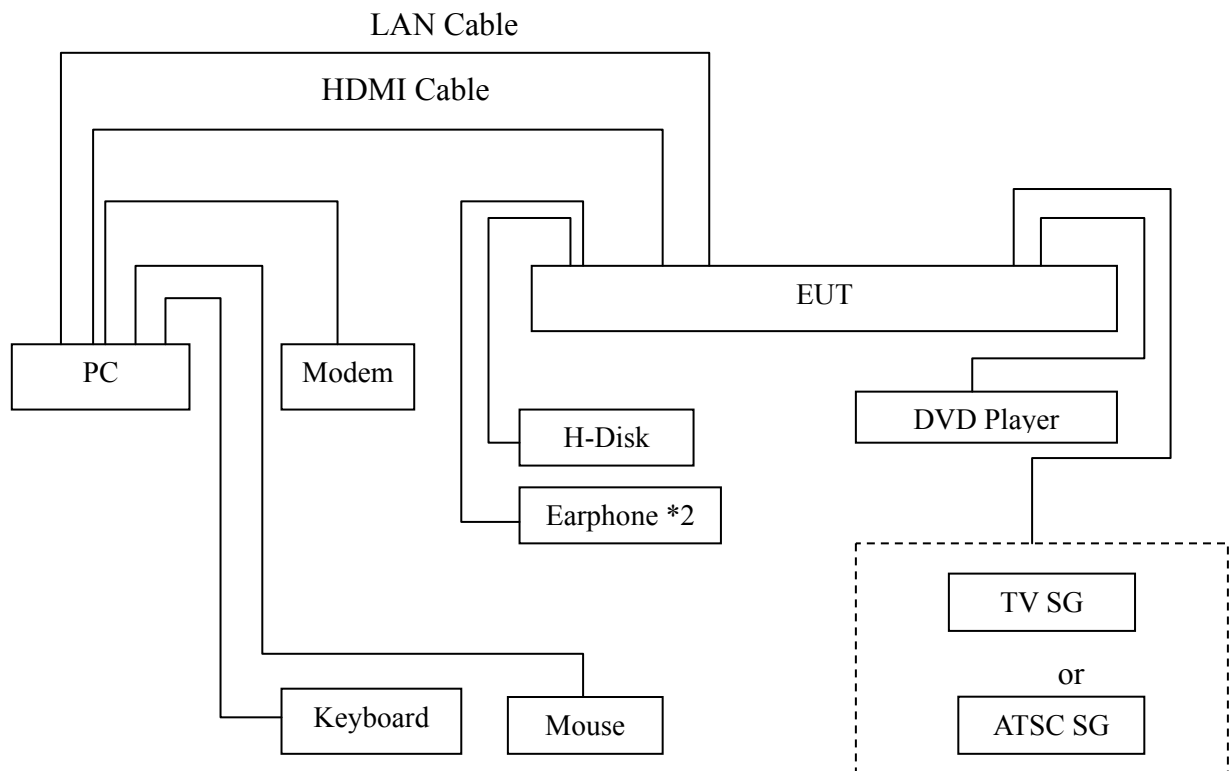

4.2.2 Radiated emission test setup

4.2.2.1 Below 1GHz

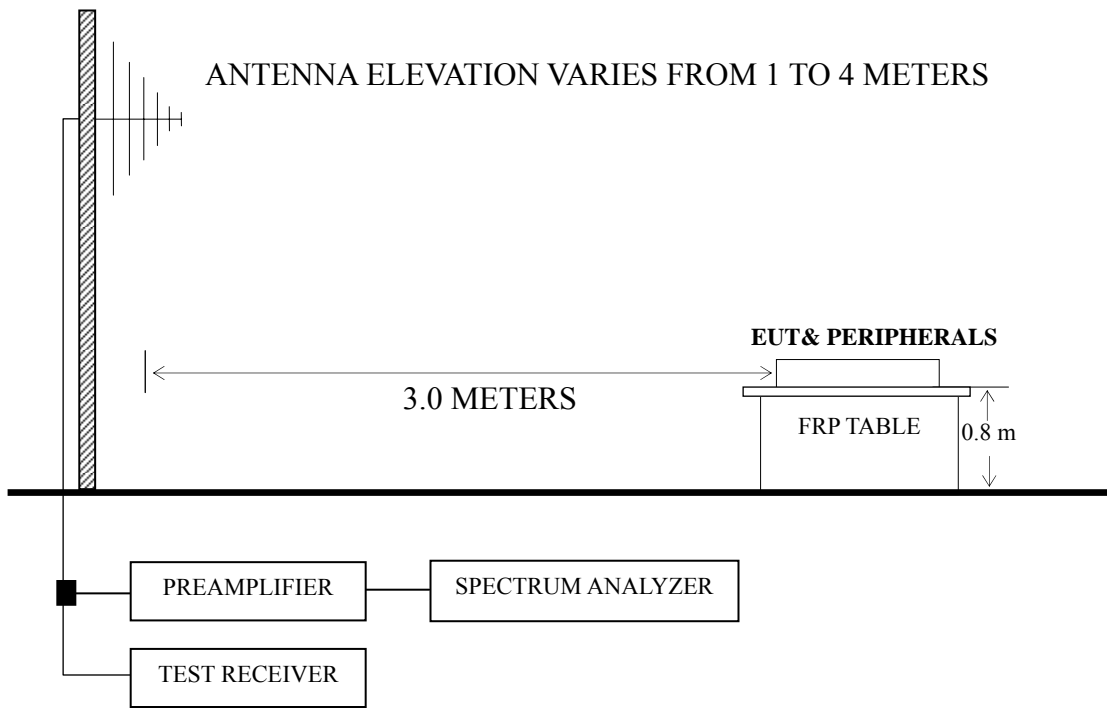

■ : 50 ohm Coaxial Switch

4.2.2.2 Above 1GHz

BORE-SIGHT ANTENNA TOWER

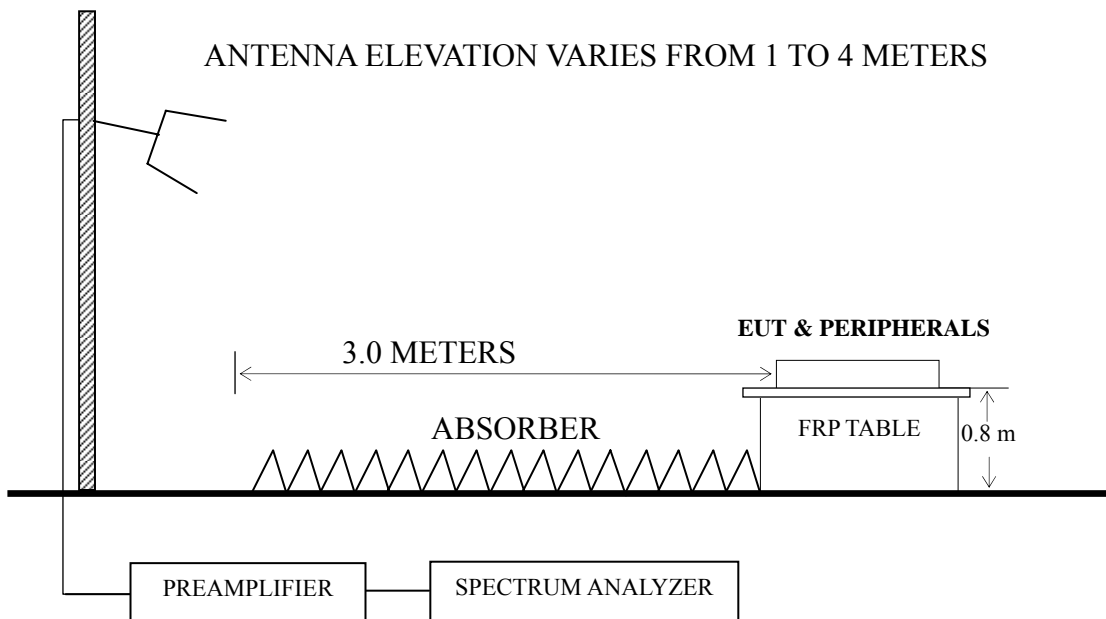

4.3 Radiated Emission Limit [FCC Part 15 Subpart B 15.109(a)]

Frequency (MHz)	Distance (m)	Field strength limits	
		($\mu\text{V/m}$)	dB ($\mu\text{V/m}$)
30 ~ 88	3	100	40.0
88 ~ 216	3	150	43.5
216 ~ 960	3	200	46.0
Above 960	3	500	54.0

NOTE 1 - Emission Level dB ($\mu\text{V/m}$) = 20 log Emission Level ($\mu\text{V/m}$)
 NOTE 2 - The tighter limit applies at the band edges.
 NOTE 3 - Distance refers to the distance in meters between the measuring instrument antenna and the closed point of any part of the device or system.
 NOTE 4 - The limits shown are based on Quasi-peak value detector.
 NOTE 5 - Above 1 GHz, the limit on peak emission is 20 dB above the maximum permitted average emission limit applicable to the EUT.

4.4 Test Configuration

The configuration of the EUT and peripherals are same as those used in conducted emission test.

Please refer to Sec.3.4.

4.5 Operating Condition of EUT

Same as conducted emission test which is listed in Sec.3.5, except for the test setup replaced by Sec.4.2.

4.6 Test Procedures

The EUT and peripherals were placed on a FRP turntable that is 0.8 meter above ground. The FRP turntable rotated 360 degrees to determine the position of the maximum emission level. The EUT was set 3 meters away from the receiving antenna, which was mounted on an antenna tower. Broadband antenna (Calibrated Bilog Antenna) was used as receiving antenna. The antenna moved up and down between 1 meter and 4 meters to find out the maximum emission level. Both horizontal and vertical polarizations of the antenna were set on measurement. In order to find the maximum emission, all of the interference cables were manipulated according to ANSI C63.4 requirements during radiated emission test.

The I.F. bandwidth of Test Receiver R&S ESCI was set at 120 kHz.

The frequency range from 30 MHz to 1000MHz was checked for all test modes.

The frequency range from 1 GHz to 2 GHz was checked for the maximum resolution test mode

The test modes were done on radiated disturbance test and all the test results are listed in Sec.4.7.

4.7 Test Results

<PASS>

The frequency and amplitude of the highest radiated emission relative the limit is reported. All the emissions not reported below are too low against the FCC limit.

Test Mode	Data Page
HDMI 1366*768@60Hz & 1kHz Playing	P23
HDMI 800*600@60Hz & 1kHz Playing	P24
HDMI 640*480@60Hz & 1kHz playing	P25
HDMI1080P	P26 - P27
USB Play	P28
LAN Play	P29

NOTE 1 – Emission Level = Antenna Factor + Cable Loss + Meter Reading. (< 1GHz);

NOTE 2 – All readings are Quasi-Peak values below or equal to 1GHz, Peak and Average values above 1GHz.

NOTE 3 – 0° was the table front facing the antenna. Degree is calculated from 0° clockwise facing the antenna.

NOTE 4 – The worst case is for HDMI 1366*768@60Hz & 1kHz Playing test mode. The worst emission at horizontal polarization was detected at 153.200 MHz with corrected signal level of 40.50 dB ($\mu\text{V}/\text{m}$) (limit is 43.50 dB ($\mu\text{V}/\text{m}$)), when the antenna was 2.10 m height and the turntable was at 295°. The worst emission at vertical polarization was detected at 153.200 MHz with corrected signal level of 40.52 dB ($\mu\text{V}/\text{m}$) (limit is 43.50 dB ($\mu\text{V}/\text{m}$)), when the antenna was 1.00 m height and the turntable was at 140°.

EUT : LED LCD TV Temperature : 22

Model No. : 32H5C Humidity : 60%RH

Test Mode : HDMI 1366*768@60Hz & 1kHz Playing Date of Test : Jul 20, 2016

Polarization	Frequency (MHz)	Meter Reading dB (μ V)	Antenna Factor (dB/m)	Cable Loss (dB)	Emission Level dB (μ V/m)	Limits dB (μ V/m)	Margin (dB)
Horizontal	74.657	25.38	8.24	0.86	34.48	40.00	5.52
	153.200	27.48	11.73	1.29	40.50	43.50	3.00
	188.413	28.47	10.06	1.44	39.97	43.50	3.53
	202.810	28.18	10.20	1.49	39.87	43.50	3.63
	440.196	20.96	16.63	2.13	39.72	46.00	6.28
	793.396	18.90	20.33	2.89	42.12	46.00	3.88
Vertical	39.576	21.31	13.76	0.64	35.71	40.00	4.29
	69.114	25.65	7.32	0.83	33.80	40.00	6.20
	153.200	27.50	11.73	1.29	40.52	43.50	2.98
	190.405	28.44	10.00	1.44	39.88	43.50	3.62
	301.422	24.57	13.64	1.76	39.97	46.00	6.03
	687.151	18.58	19.38	2.69	40.65	46.00	5.35

TEST ENGINEER: CAESAR WU

EUT : LED LCD TV Temperature : 22

Model No. : 32H5C Humidity : 60%RH

Test Mode : HDMI 800*600@60Hz & 1kHz Playing Date of Test : Jul 20, 2016

Polarization	Frequency (MHz)	Meter Reading dB (μ V)	Antenna Factor (dB/m)	Cable Loss (dB)	Emission Level dB (μ V/m)	Limits dB (μ V/m)	Margin (dB)
Horizontal	157.559	26.84	11.40	1.31	39.55	43.50	3.95
	192.419	27.64	9.95	1.45	39.04	43.50	4.46
	300.600	24.80	13.64	1.76	40.20	46.00	5.80
	397.633	19.49	16.23	2.03	37.75	46.00	8.25
	480.528	18.13	17.20	2.22	37.55	46.00	8.45
	790.619	16.96	20.30	2.89	40.15	46.00	5.85
Vertical	39.854	17.96	13.65	0.64	32.25	40.00	7.75
	64.208	27.86	6.85	0.80	35.51	40.00	4.49
	155.364	26.88	11.48	1.30	39.66	43.50	3.84
	192.419	25.28	9.95	1.45	36.68	43.50	6.82
	301.422	24.89	13.64	1.76	40.29	46.00	5.71
	396.242	20.25	16.23	2.03	38.51	46.00	7.49

TEST ENGINEER: CAESAR WU

EUT : LED LCD TV Temperature : 22

Model No. : 32H5C Humidity : 60%RH

Test Mode : HDMI 640*480@60Hz & 1kHz Playing Date of Test : Jul 11, 2016

Polarization	Frequency (MHz)	Meter Reading dB (μ V)	Antenna Factor (dB/m)	Cable Loss (dB)	Emission Level dB (μ V/m)	Limits dB (μ V/m)	Margin (dB)
Horizontal	156.458	24.89	11.45	1.31	37.65	43.50	5.85
	190.405	27.53	10.00	1.44	38.97	43.50	4.53
	265.676	22.54	13.10	1.67	37.31	46.00	8.69
	301.422	24.66	13.64	1.76	40.06	46.00	5.94
	451.135	16.61	16.80	2.16	35.57	46.00	10.43
	796.183	16.87	20.37	2.89	40.13	46.00	5.87
Vertical	41.567	19.31	12.37	0.65	32.33	40.00	7.67
	66.967	23.40	7.09	0.82	31.31	40.00	8.69
	154.821	26.04	11.50	1.30	38.84	43.50	4.66
	198.588	25.83	10.03	1.47	37.33	43.50	6.17
	301.422	23.21	13.64	1.76	38.61	46.00	7.39
	399.030	20.68	16.27	2.03	38.98	46.00	7.02

TEST ENGINEER: CAESAR WU

EUT : LED LCD TV Temperature : 22

Model No. : 32H5C Humidity : 60%RH

Test Mode : HDMI1080P Date of Test : Jul 20, 2016

Polarization	Frequency (MHz)	Meter Reading dB (μ V)	Antenna Factor (dB/m)	Cable Loss (dB)	Preamp Factor (dB)	Emission Level dB (μ V/m)	Limits dB (μ V/m)	Margin (dB)	Remark
Horizontal	151.597	25.22	11.88	1.29	--	38.39	43.50	5.11	QP
	190.270	27.90	10.00	1.44	--	39.34	43.50	4.16	
	201.393	28.55	10.13	1.48	--	40.16	43.50	3.34	
	260.144	24.32	13.40	1.66	--	39.38	46.00	6.62	
	302.481	21.75	13.68	1.76	--	37.19	46.00	8.81	
	790.619	19.44	20.30	2.89	--	42.63	46.00	3.37	
	1278.223	56.13	24.77	3.63	36.00	48.53	74.00	25.47	PK
	1499.209	55.28	25.60	3.89	35.68	49.09	74.00	24.91	
	1696.503	60.80	26.42	4.07	35.44	55.85	74.00	18.15	
	1278.223	38.28	24.77	3.63	36.00	30.68	54.00	23.32	AV
	1499.209	37.45	25.60	3.89	35.68	31.26	54.00	22.74	
	1696.503	43.24	26.42	4.07	35.44	38.29	54.00	15.71	

TEST ENGINEER: CAESAR WU

EUT : LED LCD TV Temperature : 22

Model No. : 32H5C Humidity : 60%RH

Test Mode : HDMI1080P Date of Test : Jul 20, 2016

Polarization	Frequency (MHz)	Meter Reading dB (μ V)	Antenna Factor (dB/m)	Cable Loss (dB)	Preamp Factor (dB)	Emission Level dB (μ V/m)	Limits dB (μ V/m)	Margin (dB)	Remark
Vertical	34.882	18.27	15.75	0.60	--	34.62	40.00	5.38	QP
	112.131	24.68	12.24	1.08	--	38.00	43.50	5.50	
	152.200	26.90	11.80	1.29	--	39.99	43.50	3.51	
	190.270	28.10	10.00	1.44	--	39.54	43.50	3.96	
	300.367	24.56	13.64	1.76	--	39.96	46.00	6.04	
	798.980	17.16	20.40	2.89	--	40.45	46.00	5.55	
	1226.618	53.91	24.57	3.56	36.09	45.95	74.00	28.05	PK
	1504.591	56.96	25.62	3.89	35.67	50.80	74.00	23.20	
	1690.434	59.75	26.40	4.07	35.44	54.78	74.00	19.22	
	1226.618	35.28	24.57	3.56	36.09	27.32	54.00	26.68	AV
	1504.591	38.22	25.62	3.89	35.67	32.06	54.00	21.94	
	1690.434	41.43	26.40	4.07	35.44	36.46	54.00	17.54	

EUT : LED LCD TV Temperature : 22

Model No. : 32H5C Humidity : 60%RH

Test Mode : USB Play Date of Test : Jul 20, 2016

Polarization	Frequency (MHz)	Meter Reading dB (μ V)	Antenna Factor (dB/m)	Cable Loss (dB)	Emission Level dB (μ V/m)	Limits dB (μ V/m)	Margin (dB)
Horizontal	157.007	26.30	11.43	1.31	39.04	43.50	4.46
	190.405	28.53	10.00	1.44	39.97	43.50	3.53
	266.609	23.29	13.15	1.68	38.12	46.00	7.88
	301.422	24.66	13.64	1.76	40.06	46.00	5.94
	449.556	17.18	16.80	2.16	36.14	46.00	9.86
	796.183	16.87	20.37	2.89	40.13	46.00	5.87
Vertical	40.988	20.32	12.92	0.65	33.89	40.00	6.11
	75.182	25.90	8.34	0.86	35.10	40.00	4.90
	151.067	25.26	11.95	1.29	38.50	43.50	5.00
	189.074	26.20	10.06	1.44	37.70	43.50	5.80
	301.422	23.21	13.64	1.76	38.61	46.00	7.39
	396.242	20.49	16.23	2.03	38.75	46.00	7.25

TEST ENGINEER: CAESAR WU

EUT : LED LCD TV Temperature : 22

Model No. : 32H5C Humidity : 60%RH

Test Mode : LAN Play Date of Test : Jul 20, 2016

Polarization	Frequency (MHz)	Meter Reading dB (μ V)	Antenna Factor (dB/m)	Cable Loss (dB)	Emission Level dB (μ V/m)	Limits dB (μ V/m)	Margin (dB)
Horizontal	151.597	25.85	11.88	1.29	39.02	43.50	4.48
	187.753	28.02	10.09	1.43	39.54	43.50	3.96
	199.286	26.99	10.07	1.48	38.54	43.50	4.96
	300.600	24.80	13.64	1.76	40.20	46.00	5.80
	475.499	17.22	17.16	2.22	36.60	46.00	9.40
793.396	16.11	20.33	2.89	39.33	46.00	6.67	
Vertical	41.132	19.24	12.78	0.65	32.67	40.00	7.33
	64.887	25.28	6.90	0.80	32.98	40.00	7.02
	155.364	25.88	11.48	1.30	38.66	43.50	4.84
	188.413	26.94	10.06	1.44	38.44	43.50	5.06
	304.610	22.95	13.75	1.77	38.47	46.00	7.53
396.242	20.25	16.23	2.03	38.51	46.00	7.49	

TEST ENGINEER: CAESAR WU

5 DEBUG DESCRIPTION

The following components are used during the countermeasure procedures:

Name	M/N	Manufacturer	Location
SM contact	SMR-TSL-4-3.5-5R	Qingdao Joinset.	See Internal Photos Figure 21

Note: We had required the applicant and manufacturer that all electrical and mechanical devices employed for spurious radiation suppression, including any modifications made during certification testing, must be incorporated in each unit marked

TEST ENGINEER:



(BYRON WU)

6 DEVIATION TO TEST SPECIFICATIONS

None