

Application for FCC Certificate
On Behalf of
Hisense Electric Co., Ltd.

LCD TV

Model No.	Serial No.	Brand
LHDN32V66AUS	E2010033113	Hisense

FCC ID : W9HLCDC0003

Prepared For : Hisense Electric Co., Ltd.
No.218 Qianwangang Road, Economy & Technology
Development Zone, Qingdao, China

Prepared By : Audix Technology (Shanghai) Co., Ltd.
3F 34Bldg 680 Guiping Rd,
Caohejing Hi-Tech Park,
Shanghai 200233, China

Tel: +86-21-64955500
Fax: +86-21-64955491

Report No. : ACI-F10033
Date of Test : Apr 01-06, 2010
Date of Report : Apr 07, 2010

TABLE OF CONTENTS

	Page
1 SUMMARY OF STANDARDS AND RESULTS	4
1.1 Description of Standards and Results.....	4
2 GENERAL INFORMATION	5
2.1 Description of Equipment Under Test.....	5
2.2 Peripherals.....	7
2.3 Description of Test Facility.....	9
2.4 Measurement Uncertainty.....	9
3 CONDUCTED EMISSION TEST	10
3.1 Test Equipment.....	10
3.2 Block Diagram of Test Setup.....	10
3.3 Conducted Emission Limit [FCC Part 15 Subpart B 15.107(a)].....	11
3.4 Test Configuration.....	11
3.5 Operating Condition of EUT.....	12
3.6 Test Procedures.....	12
3.7 Test Results.....	13
4 RADIATED EMISSION TEST	20
4.1 Test Equipment.....	20
4.2 Block Diagram of Test Setup.....	20
4.3 Radiated Emission Limit [FCC Part 15 Subpart B 15.109(a)].....	21
4.4 Test Configuration.....	21
4.5 Operating Condition of EUT.....	21
4.6 Test Procedures.....	22
4.7 Test Results.....	22
5 DEVIATION TO TEST SPECIFICATIONS	29
6 DEBUG DESCRIPTION	30

TEST REPORT FOR FCC CERTIFICATE

Applicant : Hisense Electric Co., Ltd.
 Manufacturer : Hisense Electric Co., Ltd.
 EUT Description : LCD TV

Model No.	Serial No.	Brand	Power Supply
LHDN32V66AUS	E2010033113	Hisense	120V/60Hz

Test Procedure Used:

*FCC RULES AND REGULATIONS PART 15 SUBPART B CLASS B OCTOBER 2009
AND ANSI C63.4-2003*

The device described above is tested by Audix Technology (Shanghai) Co., Ltd. to determine the maximum emission levels emanating from the device. The maximum emission levels are compared to the FCC Part 15 Subpart B (Class B) limits both radiated and conducted emissions.

The test results are contained in this test report and Audix Technology (Shanghai) Co., Ltd. is assumed full responsibility for the accuracy and completeness of these measurements. This report shows that the EUT (M/N: Refer to Sec.2.1; S/N: Refer to Sec.2.1) which was tested in 3m anechoic chamber Apr 01-06, 2010 is technically compliance with the FCC official limits also.

This report applies to above tested sample only. This report shall not be reproduced in part without written approval of Audix Technology (Shanghai) Co., Ltd.

This report contains data that are not covered by the NVLAP accreditation.

This report must not be used by the client to claim product certification, approval, or endorsement by NVLAP, NIST, or any agency of the federal government.

The test results for EUT's TV functions are contained in No.F10033, a Verification report.

Date of Test : Apr 01-06, 2010 Date of Report : Apr 07, 2010

Producer : 
ALAN HE / Assistant

Review : 
DIO YANG / Deputy Assistant Manager

 For and on behalf of
Audix Technology (Shanghai) Co., Ltd.

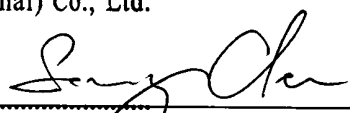
Signatory : 
Authorized Signature EMC SAMMY CHEN/ Assistant Manager

1 SUMMARY OF STANDARDS AND RESULTS

1.1 Description of Standards and Results

The EUT have been tested according to the applicable standards as referenced below:

Description of Test Item	Standard	Limits	Results
EMISSION			
Conducted Disturbance at the Mains Terminal	FCC RULES AND REGULATIONS PART 15 SUBPART B OCTOBER 2009 AND ANSI C63.4-2003	15.107(a) Class B	Pass
Radiated Disturbance	FCC RULES AND REGULATIONS PART 15 SUBPART B OCTOBER 2009 AND ANSI C63.4-2003	15.109(a) Class B	Pass

2 GENERAL INFORMATION

2.1 Description of Equipment Under Test

Description : LCD TV

Type of EUT : Production Pre-product Pro-type

Model No. : LHDN32V66AUS

Serial No. : E2010033113

Brand : Hisense

Applicant : Hisense Electric Co., Ltd.
No.218 Qianwangang Road, Economy &
Technology Development Zone, Qingdao, China

Manufacturer : Hisense Electric Co., Ltd.
No.218 Qianwangang Road, Economy &
Technology Development Zone, Qingdao, China

LCD Panel : Manufacturer : Hisense
M/N : HS32LN2-IPS

Max Resolution : 1024*768@60Hz

D-Sub Cable : Shielded, Detachable, 1.85m,
with two cores on cable

HDMI Cable : Shielded, Detachable, 1.85m,
without core on cable

Power Cord : Unshielded, Detachable, 1.80m

Remark:

The EUT is a LCD TV which input/output ports as follows:

Bottom Port:

- (1) One Component of YPbPr Port
: Connected with DVD #1
- (2) One Component of YPbPr Audio Port
: Connected with DVD #1
- (3) One HDMI1 Port
: Connected with DVD #1
- (4) One HDMI2 Port
: Connected with DVD #2/PC
- (5) One Component of AV Port
: Connected with DVD #1
- (6) One Earphone Port
: Connected with Earphone
- (7) One VGA Port
: Connected with PC
- (8) One VGA Audio Port
: Connected with PC
- (9) One ANT Port
: Connected with ATSC SG/TV SG
- (10) One COAXIAL Port
: Connected with DVD #1
- (11) One Service Port
: Do not open to customer

2.2 Peripherals

2.2.1 PC

Manufacturer : HP
Model Number : dx7400MT
Serial Number : CNG8130K89
Power Cord : Unshielded, Detachable, 1.8m
Certificate : FCC DoC; CE/EMC; VCCI; C-Tick; UL
BSMI (R33001) 3C (A000111)
MIC (E-A011-04-2659(B))

2.2.2 Printer

Manufacturer : HP
Model Number : C3990A
Serial Number : JPZX020487
Data Cable : Shielded, detachable, 1.5m
Certificate : GS, CE/EMC, C-Tick, FCC DoC

2.2.3 Keyboard

Manufacturer : Microsoft
Model Number : RT2300
Serial Number : 7668200662248
Data Cable : Shielded, undetachable, 1.8m
Certificate : CE/EMC, FCC DoC, VCCI, MIC, C-Tick,
BSMI

2.2.4 Mouse

Manufacturer : Microsoft
Model Number : RT2300
Serial Number : 6965712071551
Data Cable : Shielded, undetachable, 1.8m.
Certificate : CE/EMC, FCC DoC, VCCI, MIC, C-Tick,
BSMI

2.2.5 Modem

Manufacturer : TP-LINK
Model Number : TM-EC5658V
Serial Number : 07123301053
Data Cable : Shielded, Detachable, 1.8m
Certificate : FCC DoC, CE/EMC, CCC

2.2.6 Earphone

Manufacturer : SONY
Model Number : MDR-E808
Serial Number : 1808030805305506

2.2.7 TV Signal Generator

Manufacturer : FLUKE
Model Number : 54200m01
Serial Number : 814008
Data Cable : Shielded, detachable, 2.0m
Power Cord : Unshielded, detachable, 2.0m
Certificate : CE/EMC, FCC DoC, CCC

2.2.8 ATSC Signal Generator

Manufacturer : SENCORE
Model Number : ATSC997
Serial Number : 6790071

2.2.9 DVD #1

Manufacturer : PHILIPS
Model Number : DVP3986K/93
Serial Number : KX1A0902120108
Certificate : FCC DoC, CE/EMC, CCC

2.2.10 DVD#2

Manufacturer : PHILIPS
Model Number : DVP3986K/93
Serial Number : KX1A0902120082
Certificate : FCC DoC, CE/EMC, CCC

2.3 Description of Test Facility

Site Description (Semi-Anechoic Chamber) : Sept. 17, 1998 file on
Apr 29, 2009 Renewed
Federal Communications Commission
FCC Engineering Laboratory
7435 Oakland Mills Road
Columbia, MD 21046, USA

Name of Firm : Audix Technology (Shanghai) Co., Ltd.

Site Location : 3F 34Bldg 680 Guiping Rd,
Caohejing Hi-Tech Park,
Shanghai 200233, China

NVLAP Lab Code : 200371-0

2.4 Measurement Uncertainty

Conducted Emission Expanded Uncertainty: U = 1.26 dB
Radiated Emission Expanded Uncertainty : U = 3.02 dB

3 CONDUCTED EMISSION TEST

3.1 Test Equipment

The following test equipments are used during the conducted emission test in a shielded room:

Item	Type	Manufacturer	Model No.	Serial No.	Last Cal.	Next Cal.
1.	Test Receiver	R&S	ESCI	100841	Oct 15, 2009	Oct 15, 2010
2.	Artificial Mains Network (AMN)	R&S	ESH2-Z5	843890/011	Apr 02, 2010	Apr 02, 2011
3.	Line Impedance Stabilization Network (LISN)	Kyoritsu	KNW-407	8-1280-4	Apr 02, 2010	Apr 02, 2011
4.	50 Ω Coaxial Switch	Anritsu	MP59B	6200426389	Mar 19, 2010	Sep 19, 2010
5.	50 Ω Terminator	Anritsu	BNC	001	Apr 02, 2010	Apr 02, 2011
6.	Software	Audix	E3	SET00200 9804M592	--	--

3.2 Block Diagram of Test Setup

3.2.1 EUT & Peripherals

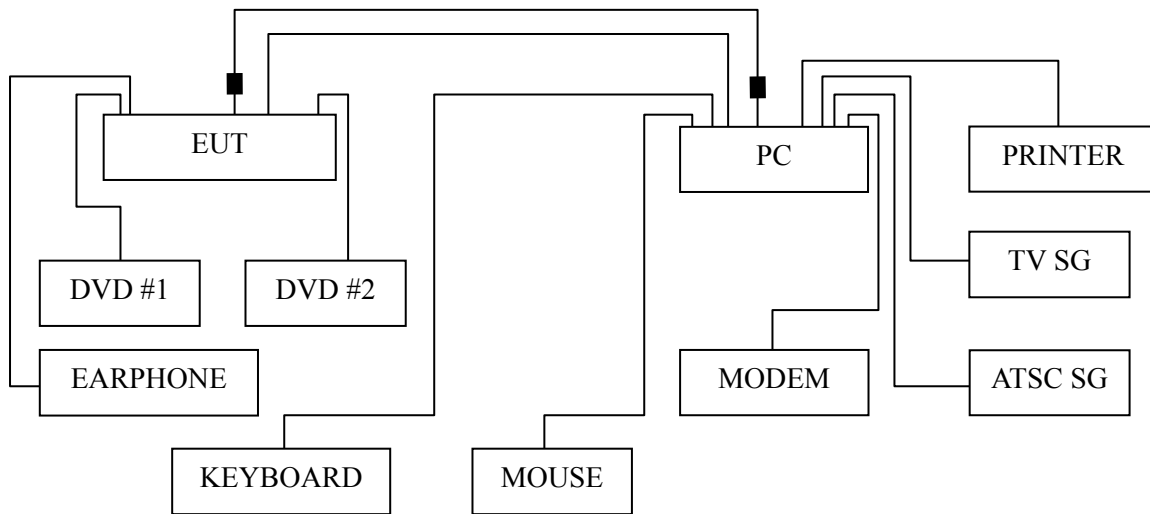

■: Ferrite core

3.2.2 Conducted Disturbance Test Setup

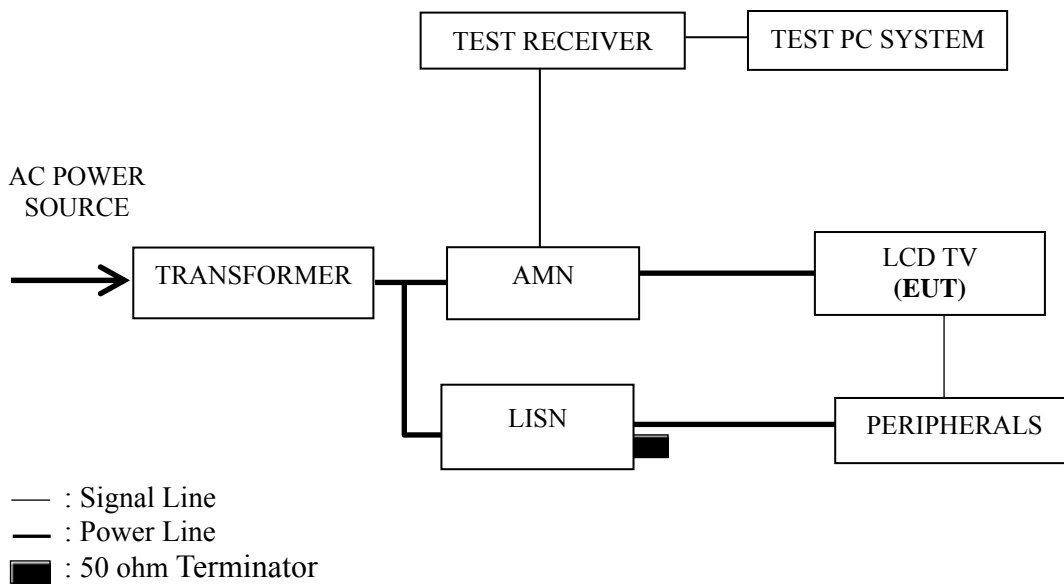

3.3 Conducted Emission Limit [FCC Part 15 Subpart B 15.107(a)]

Frequency Range (MHz)	Limits dB (μ V)	
	Quasi-peak	Average
0.15 ~ 0.5	66~56	56~46
0.5 ~ 5	56	46
5 ~ 30	60	50

NOTE 1 – The lower limit shall apply at the transition frequencies.
 NOTE 2 – The limit decreases linearly with the logarithm of the frequency in the range 0.15 MHz~0.50 MHz

3.4 Test Configuration

The EUT (listed in Sec.2.1) and the peripherals (listed in Sec 2.2) were installed as shown on Sec.3.2 to meet FCC requirement and operating in a manner that tends to maximize its emission level in a normal application.

3.5 Operating Condition of EUT

3.5.1 Setup the EUT and peripherals as shown in Sec. 3.2.

3.5.2 Turn on the power of all equipments and the EUT.

3.5.3 Set the contrast & brightness of EUT to maximum.

3.5.4 PC system ran the self-test program “EMC Test” by windows XP and sent “H” characters to EUT through graphic card, the EUT’s screen displayed and filled with “H” pattern by its resolution (Via D-Sub & HDMI Input).

3.5.5 Repeat above procedure from 3.5.3 to 3.5.4 for difference test mode.

3.5.6 The other peripherals devices were driven and operated during the test.

3.5.7 The test modes are as follows:

Test Mode
D-Sub 640*480@60Hz
D-Sub 800*600@60Hz
D-Sub 1024*768@60Hz
HDMI 640*480@60Hz
HDMI 800*600@60Hz
HDMI 1024*768@60Hz

3.6 Test Procedures

The EUT and peripherals were connected to the power mains through an Artificial Mains Network (AMN). This provided a 50 ohm coupling impedance for the measuring equipment.

Both sides of AC line (Line & Neutral) were checked for maximum conducted interference. In order to find the maximum emission, the relative positions of equipment and all of the interface cables were changed or manipulated according to ANSI C63.4:2003 during conducted emission test.

The bandwidth of R&S Test Receiver ESCI was set at 9 kHz.

The frequency range from 150 kHz to 30 MHz was checked.

The test modes were done on conducted disturbance test and all the test results are listed in Sec. 3.7.

3.7 Test Results

< **PASS** >

The frequency and amplitude of the highest conducted emission relative to the limit is reported. All emissions not reported below are too low against the prescribed limits.

Test Mode	Data Page
D-Sub 640*480@60Hz	P14
D-Sub 800*600@60Hz	P15
D-Sub 1024*768@60Hz	P16
HDMI 640*480@60Hz	P17
HDMI 800*600@60Hz	P18
HDMI 1024*768@60Hz	P19

NOTE 1 – Factor = Cable Loss + AMN Factor.

NOTE 2 – Emission Level = Meter Reading + Factor.

NOTE 3 – “QP” means “Quasi-Peak” values, “AV” means “Average” values.

NOTE 4 – The worst case is for HDMI 640*480@60Hz test mode. The worst emission is detected at 0.466 MHz (Average value) with corrected signal level of 42.46 dB (μV) (limit is 46.58 dB (μV)), when the Neutral of the EUT is connected to AMN.

EUT : LCD TV Temperature : 22°C

Model No. : LHDN32V66AUS Humidity : 48%RH

Serial No. : E2010033113 Date of Test : Apr 01, 2010

Test Mode : D-Sub 640*480@60Hz

Test Line	Frequency (MHz)	Meter Reading dB(μ V)	Factor (dB)	Emission Level dB(μ V)	Limits dB(μ V)	Margin (dB)	Remark
Line	0.182	44.35	0.27	44.62	64.42	19.80	QP
	0.466	43.13	0.47	43.60	56.58	12.98	
	0.529	43.86	0.48	44.34	56.00	11.66	
	2.044	37.39	0.55	37.94	56.00	18.06	
	5.867	37.16	0.67	37.83	60.00	22.17	
	18.039	38.82	1.06	39.88	60.00	20.12	
	0.182	34.86	0.27	35.13	54.42	19.29	AV
	0.466	40.61	0.47	41.08	46.58	5.50	
	0.529	38.25	0.48	38.73	46.00	7.27	
	2.044	27.30	0.55	27.85	46.00	18.15	
	5.867	25.85	0.67	26.52	50.00	23.48	
	18.039	36.73	1.06	37.79	50.00	12.21	
Neutral	0.264	45.30	0.32	45.62	61.29	15.67	QP
	0.461	47.20	0.43	47.63	56.67	9.04	
	0.524	46.21	0.45	46.66	56.00	9.34	
	4.269	43.01	0.63	43.64	56.00	12.36	
	8.148	43.88	0.72	44.60	60.00	15.40	
	17.849	37.91	1.01	38.92	60.00	21.08	
	0.264	37.28	0.32	37.60	51.29	13.69	AV
	0.461	41.37	0.43	41.80	46.67	4.87	
	0.524	32.80	0.45	33.25	46.00	12.75	
	4.269	24.10	0.63	24.73	46.00	21.27	
	8.148	28.39	0.72	29.11	50.00	20.89	
	17.849	28.89	1.01	29.90	50.00	20.10	

TEST ENGINEER: TED ZHU

EUT : LCD TV Temperature : 22°C

Model No. : LHDN32V66AUS Humidity : 48%RH

Serial No. : E2010033113 Date of Test : Apr 01, 2010

Test Mode : D-Sub 800*600@60Hz

Test Line	Frequency (MHz)	Meter Reading dB(μ V)	Factor (dB)	Emission Level dB(μ V)	Limits dB(μ V)	Margin (dB)	Remark
Line	0.183	45.15	0.27	45.42	64.33	18.91	QP
	0.461	46.67	0.46	47.13	56.67	9.54	
	0.529	45.72	0.48	46.20	56.00	9.80	
	1.858	44.21	0.54	44.75	56.00	11.25	
	7.526	41.88	0.70	42.58	60.00	17.42	
	18.426	37.74	1.07	38.81	60.00	21.19	
	0.183	34.62	0.27	34.89	54.33	19.44	AV
	0.461	38.35	0.46	38.81	46.67	7.86	
	0.529	37.69	0.48	38.17	46.00	7.83	
	1.858	37.93	0.54	38.47	46.00	7.53	
	7.526	27.07	0.70	27.77	50.00	22.23	
	18.426	23.07	1.07	24.14	50.00	25.86	
Neutral	0.183	46.58	0.25	46.83	64.33	17.50	QP
	0.332	48.37	0.36	48.73	59.40	10.67	
	0.529	46.70	0.45	47.15	56.00	8.85	
	1.858	42.83	0.54	43.37	56.00	12.63	
	7.977	42.02	0.72	42.74	60.00	17.26	
	18.426	38.59	1.04	39.63	60.00	20.37	
	0.183	36.92	0.25	37.17	54.33	17.16	AV
	0.332	40.35	0.36	40.71	49.40	8.69	
	0.529	37.80	0.45	38.25	46.00	7.75	
	1.858	37.40	0.54	37.94	46.00	8.06	
	7.977	27.22	0.72	27.94	50.00	22.06	
	18.426	19.99	1.04	21.03	50.00	28.97	

TEST ENGINEER: TED ZHU

EUT : LCD TV Temperature : 22°C

Model No. : LHDN32V66AUS Humidity : 48%RH

Serial No. : E2010033113 Date of Test : Apr 01, 2010

Test Mode : D-Sub 1024*768@60Hz

Test Line	Frequency (MHz)	Meter Reading dB(μ V)	Factor (dB)	Emission Level dB(μ V)	Limits dB(μ V)	Margin (dB)	Remark
Line	0.186	45.91	0.27	46.18	64.20	18.02	QP
	0.466	49.61	0.47	50.08	56.58	6.50	
	0.558	43.81	0.47	44.28	56.00	11.72	
	1.858	42.59	0.54	43.13	56.00	12.87	
	6.698	43.45	0.69	44.14	60.00	15.86	
	18.039	40.33	1.06	41.39	60.00	18.61	
	0.186	36.40	0.27	36.67	54.20	17.53	AV
	0.466	41.97	0.47	42.44	46.58	4.14	
	0.558	34.51	0.47	34.98	46.00	11.02	
	1.858	36.02	0.54	36.56	46.00	9.44	
	6.698	25.83	0.69	26.52	50.00	23.48	
	18.039	19.04	1.06	20.10	50.00	29.90	
Neutral	0.184	45.87	0.25	46.12	64.28	18.16	QP
	0.461	45.46	0.43	45.89	56.67	10.78	
	0.529	46.99	0.45	47.44	56.00	8.56	
	1.858	43.67	0.54	44.21	56.00	11.79	
	5.419	41.31	0.66	41.97	60.00	18.03	
	18.232	38.89	1.04	39.93	60.00	20.07	
	0.184	37.50	0.25	37.75	54.28	16.53	AV
	0.461	38.55	0.43	38.98	46.67	7.69	
	0.529	37.58	0.45	38.03	46.00	7.97	
	1.858	37.00	0.54	37.54	46.00	8.46	
	5.419	24.31	0.66	24.97	50.00	25.03	
	18.232	21.29	1.04	22.33	50.00	27.67	

TEST ENGINEER: TED ZHU

EUT : LCD TV Temperature : 22°C

Model No. : LHDN32V66AUS Humidity : 48%RH

Serial No. : E2010033113 Date of Test : Apr 01, 2010

Test Mode : HDMI 640*480@60Hz

Test Line	Frequency (MHz)	Meter Reading dB(μ V)	Factor (dB)	Emission Level dB(μ V)	Limits dB(μ V)	Margin (dB)	Remark
Line	0.186	45.21	0.27	45.48	64.20	18.72	QP
	0.466	46.06	0.47	46.53	56.58	10.05	
	1.129	44.91	0.49	45.40	56.00	10.60	
	1.991	42.93	0.55	43.48	56.00	12.52	
	6.352	41.88	0.67	42.55	60.00	17.45	
	18.039	38.49	1.06	39.55	60.00	20.45	
	0.186	36.85	0.27	37.12	54.20	17.08	AV
	0.466	41.95	0.47	42.42	46.58	4.16	
	1.129	39.58	0.49	40.07	46.00	5.93	
	1.991	35.24	0.55	35.79	46.00	10.21	
	6.352	25.69	0.67	26.36	50.00	23.64	
	18.039	21.33	1.06	22.39	50.00	27.61	
Neutral	0.188	46.08	0.26	46.34	64.11	17.77	QP
	0.466	48.83	0.44	49.27	56.58	7.31	
	0.558	45.33	0.45	45.78	56.00	10.22	
	1.991	43.69	0.55	44.24	56.00	11.76	
	7.687	44.17	0.71	44.88	60.00	15.12	
	18.039	38.46	1.03	39.49	60.00	20.51	
	0.188	37.84	0.26	38.10	54.11	16.01	AV
	0.466	42.02	0.44	42.46	46.58	4.12	
	0.558	35.26	0.45	35.71	46.00	10.29	
	1.991	34.56	0.55	35.11	46.00	10.89	
	7.687	27.82	0.71	28.53	50.00	21.47	
	18.039	20.62	1.03	21.65	50.00	28.35	

TEST ENGINEER: TED ZHU

EUT : LCD TV Temperature : 22°C

Model No. : LHDN32V66AUS Humidity : 48%RH

Serial No. : E2010033113 Date of Test : Apr 01, 2010

Test Mode : HDMI 800*600@60Hz

Test Line	Frequency (MHz)	Meter Reading dB(μ V)	Factor (dB)	Emission Level dB(μ V)	Limits dB(μ V)	Margin (dB)	Remark	
Line	0.188	46.78	0.28	47.06	64.11	17.05	QP	
	0.466	48.31	0.47	48.78	56.58	7.80		
	1.129	45.65	0.49	46.14	56.00	9.86		
	1.991	43.57	0.55	44.12	56.00	11.88		
	6.769	44.05	0.69	44.74	60.00	15.26		
	18.039	39.74	1.06	40.80	60.00	19.20		
	0.188	35.92	0.28	36.20	54.11	17.91	AV	
	0.466	41.94	0.47	42.41	46.58	4.17		
	1.129	39.76	0.49	40.25	46.00	5.75		
	1.991	35.31	0.55	35.86	46.00	10.14		
	6.769	26.08	0.69	26.77	50.00	23.23		
	18.039	19.87	1.06	20.93	50.00	29.07		
	Neutral	0.186	46.44	0.25	46.69	64.20	17.51	QP
		0.466	46.99	0.44	47.43	56.58	9.15	
0.558		44.69	0.45	45.14	56.00	10.86		
3.041		35.80	0.60	36.40	56.00	19.60		
6.878		37.00	0.70	37.70	60.00	22.30		
18.039		25.68	1.03	26.71	60.00	33.29		
0.186		38.39	0.25	38.64	54.20	15.56	AV	
0.466		41.90	0.44	42.34	46.58	4.24		
0.558		35.40	0.45	35.85	46.00	10.15		
3.041		24.25	0.60	24.85	46.00	21.15		
6.878		25.82	0.70	26.52	50.00	23.48		
18.039		20.82	1.03	21.85	50.00	28.15		

TEST ENGINEER: TED ZHU

EUT : LCD TV Temperature : 22°C

Model No. : LHDN32V66AUS Humidity : 48%RH

Serial No. : E2010033113 Date of Test : Apr 01, 2010

Test Mode : HDMI 1024*768@60Hz

Test Line	Frequency (MHz)	Meter Reading dB(μ V)	Factor (dB)	Emission Level dB(μ V)	Limits dB(μ V)	Margin (dB)	Remark
Line	0.184	45.04	0.27	45.31	64.28	18.97	QP
	0.466	49.02	0.47	49.49	56.58	7.09	
	1.129	45.56	0.49	46.05	56.00	9.95	
	1.991	44.33	0.55	44.88	56.00	11.12	
	6.488	45.46	0.68	46.14	60.00	13.86	
	18.039	40.81	1.06	41.87	60.00	18.13	
	0.184	36.47	0.27	36.74	54.28	17.54	AV
	0.466	41.81	0.47	42.28	46.58	4.30	
	1.129	39.63	0.49	40.12	46.00	5.88	
	1.991	36.65	0.55	37.20	46.00	8.80	
	6.488	25.99	0.68	26.67	50.00	23.33	
	18.039	19.66	1.06	20.72	50.00	29.28	
Neutral	0.186	48.36	0.25	48.61	64.20	15.59	QP
	0.466	49.51	0.44	49.95	56.58	6.63	
	0.558	45.88	0.45	46.33	56.00	9.67	
	3.041	43.87	0.60	44.47	56.00	11.53	
	6.488	44.03	0.69	44.72	60.00	15.28	
	18.039	39.33	1.03	40.36	60.00	19.64	
	0.186	38.30	0.25	38.55	54.20	15.65	AV
	0.466	41.98	0.44	42.42	46.58	4.16	
	0.558	35.44	0.45	35.89	46.00	10.11	
	3.041	24.40	0.60	25.00	46.00	21.00	
	6.488	24.52	0.69	25.21	50.00	24.79	
	18.039	19.78	1.03	20.81	50.00	29.19	

TEST ENGINEER: TED ZHU

4 RADIATED EMISSION TEST

4.1 Test Equipment

The following test equipments are used during the radiated emission test in a semi-anechoic chamber:

Item	Type	Manufacturer	Model No.	Serial No.	Last Cal.	Next Cal.
1.	Test Receiver	R&S	ESVS10	844594/001	Mar 07, 2010	Mar 07, 2011
2.	Preamplifier	Agilent	8447D	2944A10548	Mar 19, 2010	Sep 19, 2010
3.	Bi-log Antenna	TESEQ	CBL6112D	23193	May 14, 2008	May 14, 2010
4.	Spectrum Analyzer	Agilent	E7405A	MY45106600	May 19, 2009	May 19, 2010
5.	Software	Audix	E3	SET00200 9912M295-2	--	--

4.2 Block Diagram of Test Setup

4.2.1 EUT and Peripherals

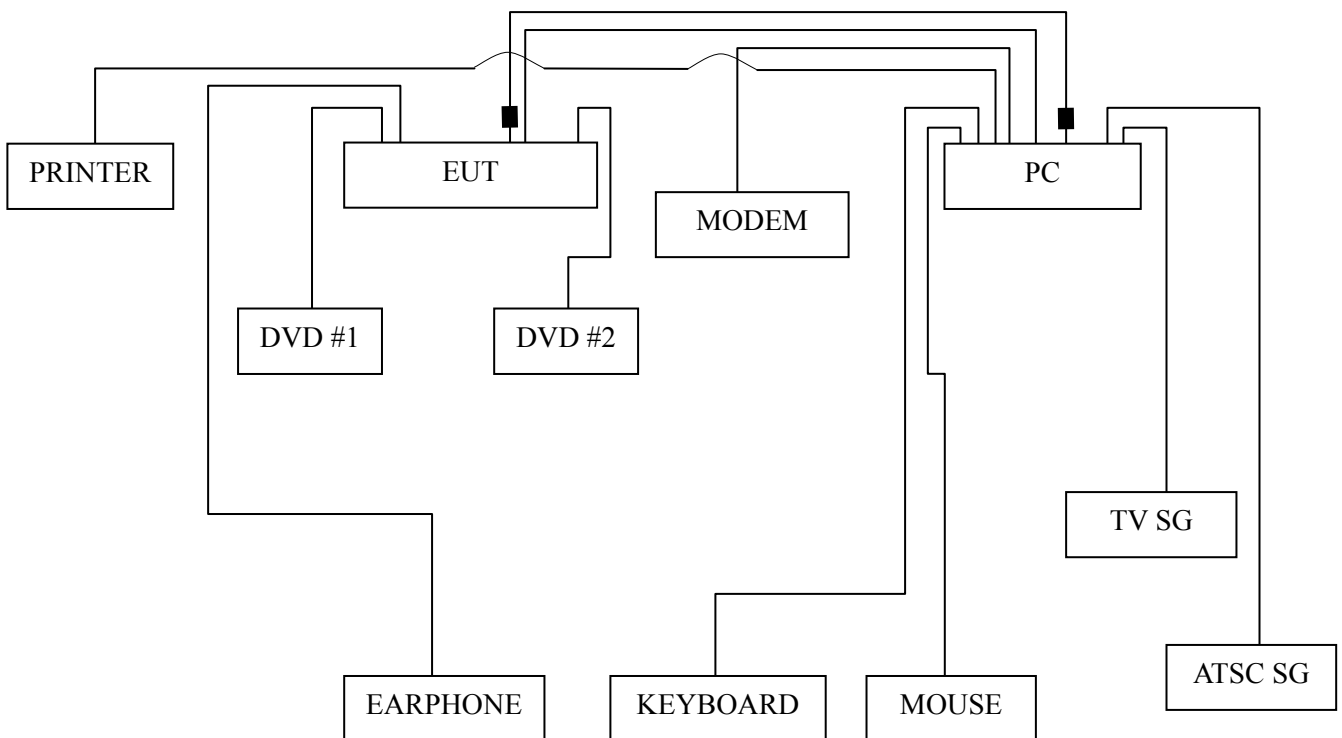

■: Ferrite core

4.2.2 Radiated emission test setup

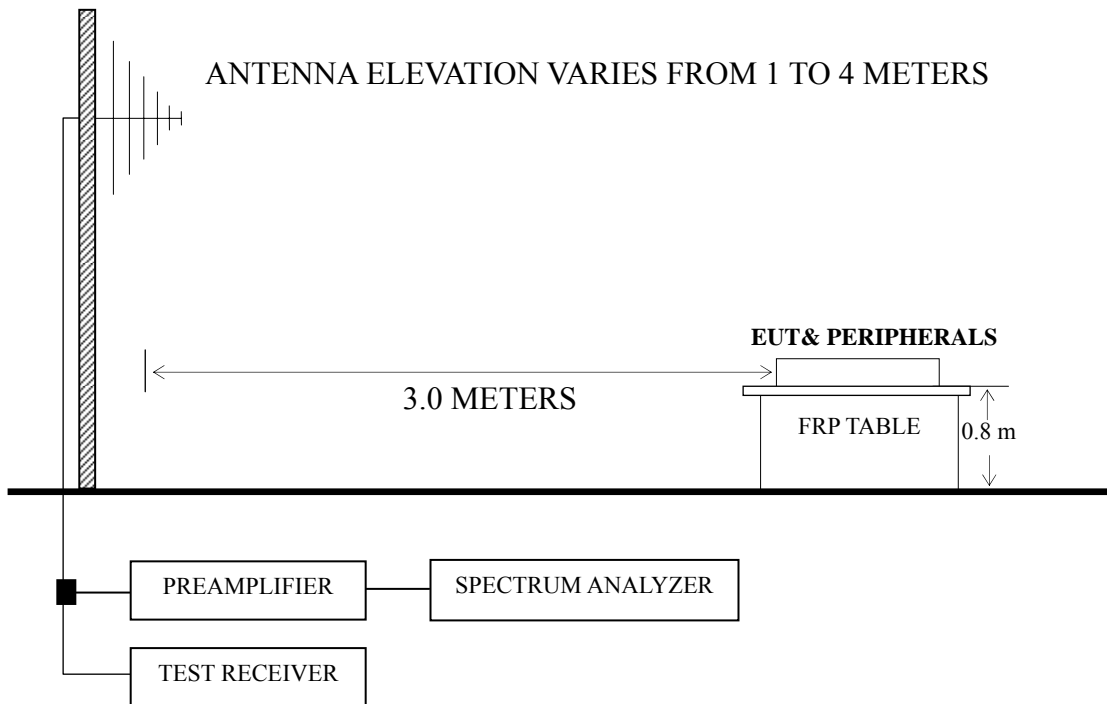

■ : 50 ohm Coaxial Switch

4.3 Radiated Emission Limit [FCC Part 15 Subpart B 15.109(a)]

Frequency (MHz)	Distance (m)	Field strength limits	
		($\mu\text{V/m}$)	dB ($\mu\text{V/m}$)
30 ~ 88	3	100	40.0
88 ~ 216	3	150	43.5
216 ~ 960	3	200	46.0
Above 960	3	500	54.0

NOTE 1 - Emission Level dB ($\mu\text{V/m}$) = 20 log Emission Level ($\mu\text{V/m}$)
 NOTE 2 - The tighter limit applies at the band edges.
 NOTE 3 - Distance refers to the distance in meters between the measuring instrument antenna and the closed point of any part of the device or system.
 NOTE 4 - The limits shown are based on Quasi-peak value detector.

4.4 Test Configuration

The configuration of the EUT and peripherals are same as those used in conducted emission test.

Please refer to Sec.3.4.

4.5 Operating Condition of EUT

Same as conducted emission test which is listed in Sec.3.5, except for the test setup replaced by Sec.4.2.

4.6 Test Procedures

The EUT and peripherals were placed on a FRP turntable that is 0.8 meter above ground. The FRP turntable rotated 360 degrees to determine the position of the maximum emission level. The EUT was set 3 meters away from the receiving antenna, which was mounted on an antenna tower. Broadband antenna (Calibrated Bilog Antenna) was used as receiving antenna. The antenna moved up and down between 1 meter and 4 meters to find out the maximum emission level. Both horizontal and vertical polarizations of the antenna were set on measurement. In order to find the maximum emission, all of the interference cables were manipulated according to ANSI C63.4:2003 requirements during radiated emission test.

The bandwidth of Test Receiver R&S ESVS10 was set at 120 kHz.

The frequency range from 30 MHz to 1000MHz was checked for all test modes.

The test modes were done on radiated disturbance test and all the test results are listed in Sec.4.7.

4.7 Test Results

<PASS>

The frequency and amplitude of the highest radiated emission relative the limit is reported. All the emissions not reported below are too low against the FCC limit.

Test Mode	Data Page
D-Sub 640*480@60Hz	P23
D-Sub 800*600@60Hz	P24
D-Sub 1024*768@60Hz	P25
HDMI 640*480@60Hz	P26
HDMI 800*600@60Hz	P27
HDMI 1024*768@60Hz	P28

NOTE 1 – Emission Level = Antenna Factor + Cable Loss + Meter Reading.

NOTE 2 – The emission levels that are 20dB below the official limit are not reported.

NOTE 3 – 0° was the table front facing the antenna. Degree is calculated from 0° clockwise facing the antenna.

NOTE 4 – The worst case is for HDMI 1024*768@60Hz test mode. The worst emission at horizontal polarization was detected at 677.96 MHz with corrected signal level of 41.34dB ($\mu\text{V/m}$) (limit is 46.00dB ($\mu\text{V/m}$)), when the antenna was 1.80 m height and the turntable was at 30°. The worst emission at vertical polarization was detected at 894.27 MHz with corrected signal level of 41.11 dB ($\mu\text{V/m}$) (limit is 46.00 dB ($\mu\text{V/m}$)), when the antenna was 1.20 m height and the turntable was at 225°.

EUT : LCD TV Temperature : 22°C

Model No. : LHDN32V66AUS Humidity : 60%RH

Serial No. : E2010033113 Date of Test : Apr 06, 2010

Test Mode : D-Sub 640*480@60Hz

Polarization	Frequency (MHz)	Meter Reading dB (μ V)	Antenna Factor (dB/m)	Cable Loss (dB)	Emission Level dB (μ V/m)	Limits dB (μ V/m)	Margin (dB)
Horizontal	78.50	26.63	7.61	0.94	35.18	40.00	4.82
	121.18	19.86	12.95	1.13	33.94	43.50	9.56
	259.89	20.88	13.1	1.64	35.62	46.00	10.38
	367.56	14.49	15.81	1.98	32.28	46.00	13.72
	490.75	14.93	17.78	2.25	34.96	46.00	11.04
	777.87	8.58	20.49	2.85	31.92	46.00	14.08
Vertical	30.97	14.88	19.03	0.64	34.55	40.00	5.45
	94.02	23.39	10.27	1.02	34.68	43.50	8.82
	201.69	21.34	10.78	1.45	33.57	43.50	9.93
	302.57	16.21	13.97	1.77	31.95	46.00	14.05
	489.78	11.67	17.78	2.25	31.70	46.00	14.30
	870.99	13.11	21.42	2.98	37.51	46.00	8.49

TEST ENGINEER: RAVEN JIN

EUT : LCD TV Temperature : 22°C

Model No. : LHDN32V66AUS Humidity : 60%RH

Serial No. : E2010033113 Date of Test : Apr 06, 2010

Test Mode : D-Sub 800*600@60Hz

Polarization	Frequency (MHz)	Meter Reading dB (μV)	Antenna Factor (dB/m)	Cable Loss (dB)	Emission Level dB (μV/m)	Limits dB (μV/m)	Margin (dB)
Horizontal	96.93	22.76	10.87	1.03	34.66	43.50	8.84
	122.15	17.30	12.91	1.14	31.35	43.50	12.15
	172.59	26.40	10.11	1.35	37.86	43.50	5.64
	237.58	21.88	12.44	1.57	35.89	46.00	10.11
	302.57	23.25	13.97	1.77	38.99	46.00	7.01
	454.86	14.67	17.29	2.17	34.13	46.00	11.87
Vertical	31.94	13.26	18.49	0.65	32.40	40.00	7.60
	93.05	24.04	10.09	1.01	35.14	43.50	8.36
	152.22	23.62	11.09	1.25	35.96	43.50	7.54
	254.07	20.46	12.99	1.61	35.06	46.00	10.94
	489.78	14.67	17.78	2.25	34.70	46.00	11.30
	974.78	12.18	22.24	4.01	38.43	54.00	15.57

TEST ENGINEER: RAVEN JIN

EUT : LCD TV Temperature : 22°C

Model No. : LHDN32V66AUS Humidity : 60%RH

Serial No. : E2010033113 Date of Test : Apr 06, 2010

Test Mode : D-Sub 1024*768@60Hz

Polarization	Frequency (MHz)	Meter Reading dB (μV)	Antenna Factor (dB/m)	Cable Loss (dB)	Emission Level dB (μV/m)	Limits dB (μV/m)	Margin (dB)
Horizontal	76.56	26.89	7.36	0.93	35.18	40.00	4.82
	93.05	24.55	10.09	1.01	35.65	43.50	7.85
	163.86	24.22	10.40	1.30	35.92	43.50	7.58
	302.57	24.25	13.97	1.77	39.99	46.00	6.01
	447.10	20.07	17.17	2.16	39.40	46.00	6.60
	690.57	18.09	19.66	2.65	40.40	46.00	5.60
Vertical	30.97	14.88	19.03	0.64	34.55	40.00	5.45
	75.59	21.78	7.24	0.92	29.94	40.00	10.06
	194.90	20.98	10.51	1.43	32.92	43.50	10.58
	257.95	23.68	13.06	1.62	38.36	46.00	7.64
	457.77	15.76	17.35	2.18	35.29	46.00	10.71
	894.27	15.46	21.63	3.02	40.11	46.00	5.89

TEST ENGINEER: RAVEN JIN

EUT : LCD TV Temperature : 22°C

Model No. : LHDN32V66AUS Humidity : 60%RH

Serial No. : E2010033113 Date of Test : Apr 06, 2010

Test Mode : HDMI 640*480@60Hz

Polarization	Frequency (MHz)	Meter Reading dB (μ V)	Antenna Factor (dB/m)	Cable Loss (dB)	Emission Level dB (μ V/m)	Limits dB (μ V/m)	Margin (dB)
Horizontal	76.56	24.89	7.36	0.93	33.18	40.00	6.82
	119.24	19.79	12.97	1.12	33.88	43.50	9.62
	217.21	24.71	11.48	1.51	37.70	46.00	8.30
	302.57	23.25	13.97	1.77	38.99	46.00	7.01
	447.10	18.07	17.17	2.16	37.40	46.00	8.60
	690.57	17.09	19.66	2.65	39.40	46.00	6.60
Vertical	31.94	11.26	18.49	0.65	30.40	40.00	9.60
	69.77	23.93	6.50	0.89	31.32	40.00	8.68
	172.59	25.65	10.11	1.35	37.11	43.50	6.39
	256.01	21.72	13.03	1.62	36.37	46.00	9.63
	457.77	16.76	17.35	2.18	36.29	46.00	9.71
	903.97	13.08	21.73	3.04	37.85	46.00	8.15

TEST ENGINEER: RAVEN JIN

EUT : LCD TV Temperature : 22°C

Model No. : LHDN32V66AUS Humidity : 60%RH

Serial No. : E2010033113 Date of Test : Apr 06, 2010

Test Mode : HDMI 800*600@60Hz

Polarization	Frequency (MHz)	Meter Reading dB (μ V)	Antenna Factor (dB/m)	Cable Loss (dB)	Emission Level dB (μ V/m)	Limits dB (μ V/m)	Margin (dB)
Horizontal	79.47	26.07	7.72	0.94	34.73	40.00	5.27
	94.99	25.86	10.45	1.02	37.33	43.50	6.17
	172.59	27.40	10.11	1.35	38.86	43.50	4.64
	217.21	26.71	11.48	1.51	39.70	46.00	6.30
	302.57	24.25	13.97	1.77	39.99	46.00	6.01
	447.10	19.07	17.17	2.16	38.40	46.00	7.60
Vertical	31.94	13.26	18.49	0.65	32.40	40.00	7.60
	74.62	26.79	7.11	0.92	34.82	40.00	5.18
	94.02	21.85	10.27	1.02	33.14	43.50	10.36
	195.87	23.19	10.54	1.43	35.16	43.50	8.34
	254.07	20.46	12.99	1.61	35.06	46.00	10.94
	489.78	12.67	17.78	2.25	32.70	46.00	13.30

TEST ENGINEER: RAVEN JIN

EUT : LCD TV Temperature : 22°C

Model No. : LHDN32V66AUS Humidity : 60%RH

Serial No. : E2010033113 Date of Test : Apr 06, 2010

Test Mode : HDMI 1024*768@60Hz

Polarization	Frequency (MHz)	Meter Reading dB (μ V)	Antenna Factor (dB/m)	Cable Loss (dB)	Emission Level dB (μ V/m)	Limits dB (μ V/m)	Margin (dB)
Horizontal	76.56	25.89	7.36	0.93	34.18	40.00	5.82
	121.18	20.86	12.95	1.13	34.94	43.50	8.56
	265.71	20.74	13.22	1.65	35.61	46.00	10.39
	451.95	18.37	17.26	2.17	37.80	46.00	8.20
	677.96	19.12	19.59	2.63	41.34	46.00	4.66
	871.96	13.08	21.42	2.98	37.48	46.00	8.52
Vertical	30.00	13.21	19.60	0.63	33.44	40.00	6.56
	42.61	16.89	12.39	0.74	30.02	40.00	9.98
	116.33	23.03	12.78	1.12	36.93	43.50	6.57
	257.95	23.68	13.06	1.62	38.36	46.00	7.64
	489.78	15.67	17.78	2.25	35.70	46.00	10.30
	894.27	16.46	21.63	3.02	41.11	46.00	4.89

TEST ENGINEER: RAVEN JIN

5 DEVIATION TO TEST SPECIFICATIONS

None.

6 DEBUG DESCRIPTION

The following components are used during the countermeasure procedures:

Name	M/N	Manufacturer	Location
Ferrite core	ZCAT3035-1330\ROH	FEELUX	See Internal Photo Figure 16
		Rui Feng Electronic Co., Ltd.	
		Hai An Magnetic Material No.2 Factory	
Ferrite core	ZCAT1519-0830\ROH	FEELUX	See Internal Photo Figure 17, 18
		Rui Feng Electronic Co., Ltd.	
		Hai An Magnetic Material No.2 Factory	

Note: We had required the applicant and manufacturer that all electrical and mechanical devices employed for spurious radiation suppression, including any modifications made during certification testing, must be incorporated in each unit marked

TEST ENGINEER:



(RAVEN JIN)