

Application for FCC Certificate
On Behalf of
Hisense Electric Co., Ltd.

LCD TV

Model No.: LEDN24K15PAM

Serial No.: E2010092801

Brand: Hisense

FCC ID : W9HLCDA0004

Prepared For : Hisense Electric Co., Ltd.
No.218 Qianwangang Road, Economy & Technology
Development Zone, Qingdao, China

Prepared By : Audix Technology (Shanghai) Co., Ltd.
3F 34Bldg 680 Guiping Rd,
Caohejing Hi-Tech Park,
Shanghai 200233, China

Tel: +86-21-64955500

Fax: +86-21-64955491

Report No. : ACI-F10142
Date of Test : Oct 13 – 18, 2010
Date of Report : Oct 21, 2010

TABLE OF CONTENTS

	Page
1 SUMMARY OF STANDARDS AND RESULTS	4
1.1 Description of Standards and Results.....	4
2 GENERAL INFORMATION	5
2.1 Description of Equipment Under Test.....	5
2.2 Peripherals.....	6
2.3 Description of Test Facility.....	8
2.4 Measurement Uncertainty.....	8
3 CONDUCTED EMISSION TEST	9
3.1 Test Equipment.....	9
3.2 Block Diagram of Test Setup.....	9
3.3 Conducted Emission Limit [FCC Part 15 Subpart B 15.107(a)].....	10
3.4 Test Configuration.....	10
3.5 Operating Condition of EUT.....	11
3.6 Test Procedures.....	11
3.7 Test Results.....	12
4 RADIATED EMISSION TEST	19
4.1 Test Equipment.....	19
4.2 Block Diagram of Test Setup.....	19
4.3 Radiated Emission Limit [FCC Part 15 Subpart B 15.109(a)].....	20
4.4 Test Configuration.....	20
4.5 Operating Condition of EUT.....	20
4.6 Test Procedures.....	21
4.7 Test Results.....	22
5 DEVIATION TO TEST SPECIFICATIONS	31
6 DEBUG DESCRIPTION	32

TEST REPORT FOR FCC CERTIFICATE

Applicant : Hisense Electric Co., Ltd.
 Manufacturer : Hisense Electric Co., Ltd.
 EUT Description : LCD TV
 (A) Model No. : LEDN24K15PAM
 (B) Serial No. : E2010092801
 (C) Brand : Hisense
 (D) Power Supply : 120V/60Hz

Test Procedure Used:

*FCC RULES AND REGULATIONS PART 15 SUBPART B CLASS B OCTOBER 2009
AND ANSI C63.4-2003*

The device described above is tested by Audix Technology (Shanghai) Co., Ltd. to determine the maximum emission levels emanating from the device. The maximum emission levels are compared to the FCC Part 15 Subpart B (Class B) limits both radiated and conducted emissions.

The test results are contained in this test report and Audix Technology (Shanghai) Co., Ltd. is assumed full responsibility for the accuracy and completeness of these measurements. This report shows that the EUT (M/N: LEDN24K15PAM; S/N: E2010092801) which was tested in 3m anechoic chamber Oct 13 – 18, 2010 is technically compliance with the FCC official limits also.

This report applies to above tested sample only. This report shall not be reproduced in part without written approval of Audix Technology (Shanghai) Co., Ltd.

This report contains data that are not covered by the NVLAP accreditation.

This report must not be used by the client to claim product certification, approval, or endorsement by NVLAP, NIST, or any agency of the federal government.

The test results for EUT's TV functions are contained in No.F10143, a Verification report.

Date of Test : Oct 13 – 18, 2010 Date of Report : Oct 21, 2010

Producer : *Kathy Wang*
 KATHY WANG / Assistant

Review : *Dio Yang*
 DIO YANG / Deputy Assistant Manager

 For and on behalf of
 Audix Technology (Shanghai) Co., Ltd.

Signatory : *Sammy Chen*
 Authorized Signature EMC SAMMY CHEN / Deputy Manager

1 SUMMARY OF STANDARDS AND RESULTS

1.1 Description of Standards and Results

The EUT have been tested according to the applicable standards as referenced below:

Description of Test Item	Standard	Limits	Results
EMISSION			
Conducted Disturbance at the Mains Terminal	FCC RULES AND REGULATIONS PART 15 SUBPART B OCTOBER 2009 AND ANSI C63.4-2003	15.107(a) Class B	Pass
Radiated Disturbance	FCC RULES AND REGULATIONS PART 15 SUBPART B OCTOBER 2009 AND ANSI C63.4-2003	15.109(a) Class B	Pass

2 GENERAL INFORMATION

2.1 Description of Equipment Under Test

Description : LCD TV

Type of EUT : Production Pre-product Pro-type

Model No. : LEDN24K15PAM

Serial No. : E2010092801

Brand : Hisense

Applicant : Hisense Electric Co., Ltd.
No.218 Qianwangang Road, Economy &
Technology Development Zone, Qingdao, China

Manufacturer : Hisense Electric Co., Ltd.
No.218 Qianwangang Road, Economy &
Technology Development Zone, Qingdao, China

LED Panel : Manufacturer : CHI MEI OPTOELECTRONICS
M/N : V236H1-LE2

Max Resolution : 1280*1024@60Hz

D-Sub Cable : Shielded, Detachable, 1.85m,
with two cores on cable

HDMI Cable : Shielded, Detachable, 1.85m,
without core on cable

Power Cord : Unshielded, Detachable, 1.80m

Remark:

The EUT is a LCD TV which input/output ports as follows:

Side Port:

- (1) One Earphone Port : Connected with Earphone
- (2) One VGA Port : Connected with PC
- (3) One VGA Audio Port: : Connected with PC
- (4) One ANT Port : Connected with ATSC SG/TV SG
- (5) One Service (USB) Port : Do not open to customer

Back Port

- (1) One HDMI Port : Connected with DVD
- (2) One Component of AV Port : Connected with DVD
- (3) One Component of YPbPr Port : Connected with DVD
- (4) One Component of YPbPr Audio Port : Connected with DVD
- (5) One Component of AV Out Port: : Connected with TV

2.2 Peripherals

2.2.1 PC

Manufacturer : HP
 Model Number : dx7200MT
 Serial Number : CNG622017W
 Power Cord : Unshielded, Detachable, 1.8m
 Certificate : FCC DoC; CE/EMC; VCCI; C-Tick; UL
 BSMI (R33001) 3C (A000111)
 MIC (E-A011-04-2659(B))

2.2.2 Printer

Manufacturer : HP
 Model Number : C3990A
 Serial Number : JPZX020487
 Data Cable : Shielded, detachable, 1.5m
 Certificate : GS, CE/EMC, C-Tick, FCC DoC

2.2.3 Keyboard

Manufacturer : Microsoft
 Model Number : RT2300
 Serial Number : 7668200662248
 Data Cable : Shielded, undetachable ,1.8m
 Certificate : CE/EMC, FCC DoC, VCCI, MIC, C-Tick,
 BSMI

2.2.4 Mouse

Manufacturer : Microsoft
Model Number : RT2300
Serial Number : 6965712071551
Data Cable : Shielded, undetachable, 1.8m.
Certificate : CE/EMC, FCC DoC, VCCI, MIC, C-Tick,
BSMI

2.2.5 Modem

Manufacturer : TP Link
Model Number : TM-EC5658V
Serial Number : 07123301053
Data Cable : Shielded, undetachable, 1.8m.
Certificate : CE/EMC, FCC DoC, VCCI, MIC, C-Tick,
BSMI

2.2.6 Earphone

Manufacturer : SONY
Model Number : MDR-E808
Serial Number : 1808030805305506

2.2.7 TV Signal Generator

Manufacturer : FLUKE
Model Number : 54200m01
Serial Number : 814008
Data Cable : Shielded, detachable, 2.0m
Power Cord : Unshielded, detachable, 2.0m
Certificate : CE/EMC, FCC DoC, CCC

2.2.8 ATSC Signal Generator

Manufacturer : SENCORE
Model Number : ATSC997
Serial Number : 6790071

2.2.9 DVD

Manufacturer : LG
Model Number : DF9921N
Serial Number : 3850R-M846W
Certificate : FCC DoC, CE/EMC, CCC

2.2.10 Speaker

Manufacturer : DIBA
Model Number : FS-04
Serial Number : 002

2.2.11 TV SG

Manufacturer : SOYEA
Model Number : V1453(M)

2.3 Description of Test Facility

Site Description (No.3 3m Chamber) : Sept. 17, 1998 file on
Apr 29, 2009 Renewed
Federal Communications Commission
FCC Engineering Laboratory
7435 Oakland Mills Road
Columbia, MD 21046, USA

Name of Firm : Audix Technology (Shanghai) Co., Ltd.

Site Location : 3F 34Bldg 680 Guiping Rd,
Caohejing Hi-Tech Park,
Shanghai 200233, China

NVLAP Lab Code : 200371-0

2.4 Measurement Uncertainty

Conducted Emission Expanded Uncertainty: U = 1.26 dB
Radiated Emission Expanded Uncertainty : U = 3.02 dB

3 CONDUCTED EMISSION TEST

3.1 Test Equipment

The following test equipments are used during the conducted emission test in a shielded room:

Item	Type	Manufacturer	Model No.	Serial No.	Last Cal.	Next Cal.
1.	Test Receiver	R&S	ESCI	100841	Oct 15, 2009	Oct 15, 2010
2.	Artificial Mains Network (AMN)	R&S	ESH2-Z5	843890/011	Apr 02, 2010	Apr 02, 2011
3.	Line Impedance Stabilization Network (LISN)	Kyoritsu	KNW-407	8-1280-4	Apr 02, 2010	Apr 02, 2011
4.	50 Ω Coaxial Switch	Anritsu	MP59B	6200426389	Sep 19, 2010	Mar 19, 2011
5.	50 Ω Terminator	Anritsu	BNC	001	Apr 02, 2010	Apr 02, 2011
6.	Software	Audix	E3	SET00200 9804M592	--	--

3.2 Block Diagram of Test Setup

3.2.1 EUT & Peripherals

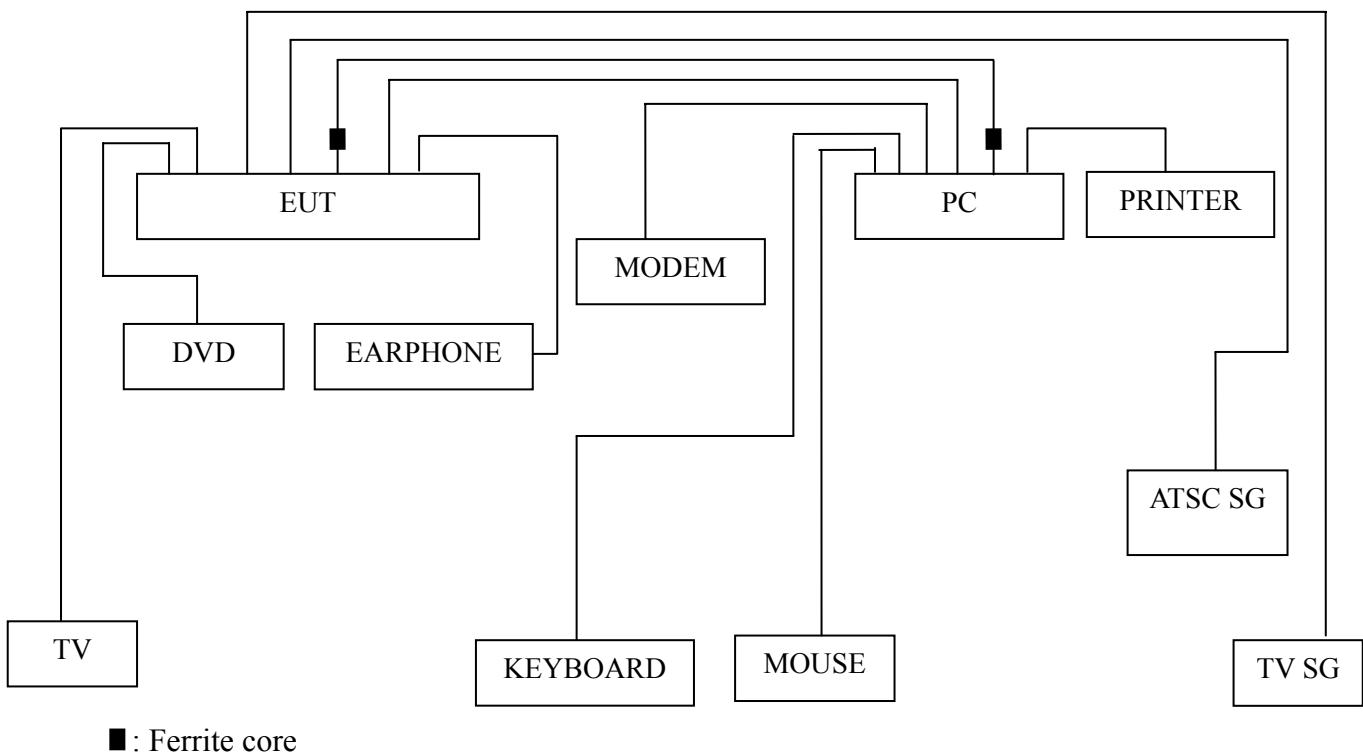

3.2.2 Conducted Disturbance Test Setup

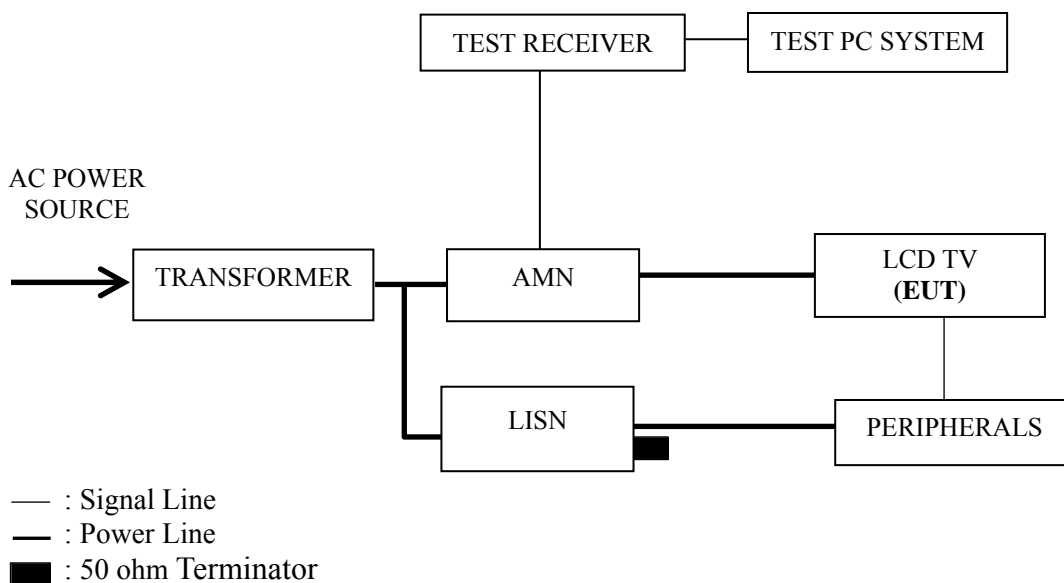

3.3 Conducted Emission Limit [FCC Part 15 Subpart B 15.107(a)]

Frequency Range (MHz)	Limits dB (μ V)	
	Quasi-peak	Average
0.15 ~ 0.5	66~56	56~46
0.5 ~ 5	56	46
5 ~ 30	60	50

NOTE 1 – The lower limit shall apply at the transition frequencies.
 NOTE 2 – The limit decreases linearly with the logarithm of the frequency in the range 0.15 MHz~0.50 MHz

3.4 Test Configuration

The EUT (listed in Sec.2.1) and the peripherals (listed in Sec 2.2) were installed as shown on Sec.3.2 to meet FCC requirement and operating in a manner that tends to maximize its emission level in a normal application.

3.5 Operating Condition of EUT

3.5.1 Setup the EUT and peripherals as shown in Sec. 3.2.

3.5.2 Turn on the power of all equipments and the EUT.

3.5.3 Set the contrast & brightness of EUT to maximum.

3.5.4 PC system ran the self-test program “EMC Test” by windows XP and sent “H” characters to EUT through graphic card, the EUT’s screen displayed and filled with “H” pattern by its resolution (Via D-Sub & HDMI Input).

3.5.5 Repeat above procedure 3.5.4 for difference test mode.

3.5.6 The other peripherals devices were driven and operated during the test.

3.5.7 The test modes are as follows:

Test Mode
D-Sub 640*480@60Hz
D-Sub 800*600@60Hz
D-Sub 1280*1024@60Hz
HDMI 640*480@60Hz
HDMI 800*600@60Hz
HDMI 1280*1024@60Hz

3.6 Test Procedures

The EUT and peripherals were connected to the power mains through an Artificial Mains Network (AMN). This provided a 50 ohm coupling impedance for the measuring equipment.

Both sides of AC line (Line & Neutral) were checked for maximum conducted interference. In order to find the maximum emission, the relative positions of equipment and all of the interface cables were changed or manipulated according to ANSI C63.4:2003 during conducted emission test.

The bandwidth of R&S Test Receiver ESCI was set at 9 kHz.

The frequency range from 150 kHz to 30 MHz was checked.

The test modes were done on conducted disturbance test and all the test results are listed in Sec. 3.7.

3.7 Test Results

< **PASS** >

The frequency and amplitude of the highest conducted emission relative to the limit is reported. All emissions not reported below are too low against the prescribed limits.

Test Mode	Data Page
D-Sub 640*480@60Hz	P13
D-Sub 800*600@60Hz	P14
D-Sub 1280*1024@60Hz	P15
HDMI 640*480@60Hz	P16
HDMI 800*600@60Hz	P17
HDMI 1280*1024@60Hz	P18

NOTE 1 – Factor = Cable Loss + AMN Factor.

NOTE 2 – Emission Level = Meter Reading + Factor.

NOTE 3 – “QP” means “Quasi-Peak” values, “AV” means “Average” values.

NOTE 4 – The worst case is for D-Sub 640*480@60Hz test mode. The worst emission is detected at 0.150 MHz (Quasi-Peak value) with corrected signal level of 55.46 dB (μ V) (limit is 66.00 dB (μ V)), when the Neutral of the EUT is connected to AMN.

EUT : LCD TV Temperature : 22°C

Model No. : LEDN24K15PAM Humidity : 48%RH

Serial No. : E2010092801 Date of Test : Oct 13, 2010

Test Mode : D-Sub 640*480@60Hz

Test Line	Frequency (MHz)	Meter Reading dB(μ V)	Factor (dB)	Emission Level dB(μ V)	Limits dB(μ V)	Margin (dB)	Remark
Line	0.150	51.29	0.32	51.61	66.00	14.39	QP
	0.300	44.37	0.39	44.76	60.24	15.48	
	0.471	39.80	0.48	40.28	56.49	16.21	
	6.352	42.63	0.82	43.45	60.00	16.55	
	8.916	44.71	0.97	45.68	60.00	14.32	
	18.622	42.63	1.69	44.32	60.00	15.68	
	0.150	41.28	0.32	41.60	56.00	14.40	AV
	0.300	32.21	0.39	32.60	50.24	17.64	
	0.471	28.48	0.48	28.96	46.49	17.53	
	6.352	31.29	0.82	32.11	50.00	17.89	
	8.916	31.28	0.97	32.25	50.00	17.75	
	18.622	31.98	1.69	33.67	50.00	16.33	
Neutral	0.150	55.09	0.37	55.46	66.00	10.54	QP
	0.300	46.93	0.45	47.38	60.24	12.86	
	0.471	43.34	0.51	43.85	56.49	12.64	
	8.729	45.44	0.99	46.43	60.00	13.57	
	18.426	44.62	1.51	46.13	60.00	13.87	
	28.302	45.94	1.87	47.81	60.00	12.19	
	0.150	42.13	0.37	42.50	56.00	13.50	AV
	0.300	32.15	0.45	32.60	50.24	17.64	
	0.471	33.21	0.51	33.72	46.49	12.77	
	8.729	32.15	0.99	33.14	50.00	16.86	
	18.426	31.24	1.51	32.75	50.00	17.25	
	28.302	31.24	1.87	33.11	50.00	16.89	

TEST ENGINEER: WENCY YANG

EUT : LCD TV Temperature : 22°C

Model No. : LEDN24K15PAM Humidity : 48%RH

Serial No. : E2010092801 Date of Test : Oct 13, 2010

Test Mode : D-Sub 800*600@60Hz

Test Line	Frequency (MHz)	Meter Reading dB(μ V)	Factor (dB)	Emission Level dB(μ V)	Limits dB(μ V)	Margin (dB)	Remark
Line	0.150	51.65	0.37	52.02	66.00	13.98	QP
	0.297	46.15	0.45	46.60	60.32	13.72	
	0.471	41.07	0.51	41.58	56.49	14.91	
	6.285	42.35	0.86	43.21	60.00	16.79	
	8.729	43.23	0.99	44.22	60.00	15.78	
	28.003	43.76	1.86	45.62	60.00	14.38	
	0.150	41.25	0.37	41.62	56.00	14.38	AV
	0.297	32.14	0.45	32.59	50.32	17.73	
	0.471	32.14	0.51	32.65	46.49	13.84	
	6.285	31.27	0.86	32.13	50.00	17.87	
	8.729	30.28	0.99	31.27	50.00	18.73	
	28.003	31.27	1.86	33.13	50.00	16.87	
Neutral	0.150	50.40	0.32	50.72	66.00	15.28	QP
	0.297	43.93	0.39	44.32	60.32	16.00	
	0.743	37.98	0.49	38.47	56.00	17.53	
	6.252	42.49	0.82	43.31	60.00	16.69	
	8.637	44.97	0.95	45.92	60.00	14.08	
	18.039	44.66	1.66	46.32	60.00	13.68	
	0.150	40.21	0.32	40.53	56.00	15.47	AV
	0.297	33.25	0.39	33.64	50.32	16.68	
	0.743	27.52	0.49	28.01	46.00	17.99	
	6.252	31.27	0.82	32.09	50.00	17.91	
	8.637	31.75	0.95	32.70	50.00	17.30	
	18.039	31.25	1.66	32.91	50.00	17.09	

TEST ENGINEER: WENCY YANG

EUT : LCD TV Temperature : 22°C

Model No. : LEDN24K15PAM Humidity : 48%RH

Serial No. : E2010092801 Date of Test : Oct 13, 2010

Test Mode : D-Sub 1280*1024@60Hz

Test Line	Frequency (MHz)	Meter Reading dB(μ V)	Factor (dB)	Emission Level dB(μ V)	Limits dB(μ V)	Margin (dB)	Remark
Line	0.150	52.42	0.37	52.79	66.00	13.21	QP
	0.297	45.95	0.45	46.40	60.32	13.92	
	0.471	41.39	0.51	41.90	56.49	14.59	
	6.252	41.36	0.86	42.22	60.00	17.78	
	8.592	42.77	0.99	43.76	60.00	16.24	
	29.061	43.34	1.88	45.22	60.00	14.78	
	0.150	40.42	0.37	40.79	56.00	15.21	AV
	0.297	32.14	0.45	32.59	50.32	17.73	
	0.471	31.27	0.51	31.78	46.49	14.71	
	6.252	31.24	0.86	32.10	50.00	17.90	
	8.592	31.27	0.99	32.26	50.00	17.74	
	29.061	33.21	1.88	35.09	50.00	14.91	
Neutral	0.150	49.00	0.32	49.32	66.00	16.68	QP
	0.297	44.25	0.39	44.64	60.32	15.68	
	0.471	38.76	0.48	39.24	56.49	17.25	
	0.743	38.17	0.49	38.66	56.00	17.34	
	8.592	44.84	0.95	45.79	60.00	14.21	
	19.532	43.72	1.74	45.46	60.00	14.54	
	0.150	32.15	0.32	32.47	56.00	23.53	AV
	0.297	32.15	0.39	32.54	50.32	17.78	
	0.471	28.15	0.48	28.63	46.49	17.86	
	0.743	28.16	0.49	28.65	46.00	17.35	
	8.592	31.25	0.95	32.20	50.00	17.80	
	19.532	33.21	1.74	34.95	50.00	15.05	

TEST ENGINEER: WENCY YANG

EUT : LCD TV Temperature : 22°C

Model No. : LEDN24K15PAM Humidity : 48%RH

Serial No. : E2010092801 Date of Test : Oct 13, 2010

Test Mode : HDMI 640*480@60Hz

Test Line	Frequency (MHz)	Meter Reading dB(μ V)	Factor (dB)	Emission Level dB(μ V)	Limits dB(μ V)	Margin (dB)	Remark
Line	0.150	49.90	0.32	50.22	66.00	15.78	QP
	0.297	43.76	0.39	44.15	60.32	16.17	
	0.476	38.50	0.48	38.98	56.41	17.43	
	1.184	37.56	0.52	38.08	56.00	17.92	
	8.412	44.40	0.95	45.35	60.00	14.65	
	19.326	43.99	1.73	45.72	60.00	14.28	
	0.150	39.89	0.32	40.21	56.00	15.79	AV
	0.297	33.77	0.39	34.16	50.32	16.16	
	0.476	28.85	0.48	29.33	46.41	17.08	
	1.184	27.55	0.52	28.07	46.00	17.93	
	8.412	34.40	0.95	35.35	50.00	14.65	
	19.326	33.91	1.73	35.64	50.00	14.36	
Neutral	0.150	52.20	0.37	52.57	66.00	13.43	QP
	0.297	46.26	0.45	46.71	60.32	13.61	
	0.471	39.94	0.51	40.45	56.49	16.04	
	6.056	41.40	0.85	42.25	60.00	17.75	
	8.412	42.81	0.98	43.79	60.00	16.21	
	19.326	43.43	1.57	45.00	60.00	15.00	
	0.150	42.19	0.37	42.56	56.00	13.44	AV
	0.297	36.25	0.45	36.70	50.32	13.62	
	0.471	29.94	0.51	30.45	46.49	16.04	
	6.056	31.39	0.85	32.24	50.00	17.76	
	8.412	32.81	0.98	33.79	50.00	16.21	
	19.326	33.42	1.57	34.99	50.00	15.01	

TEST ENGINEER: WENCY YANG

EUT : LCD TV Temperature : 22°C

Model No. : LEDN24K15PAM Humidity : 48%RH

Serial No. : E2010092801 Date of Test : Oct 13, 2010

Test Mode : HDMI 800*600@60Hz

Test Line	Frequency (MHz)	Meter Reading dB(μ V)	Factor (dB)	Emission Level dB(μ V)	Limits dB(μ V)	Margin (dB)	Remark
Line	0.150	53.13	0.37	53.50	66.00	12.50	QP
	0.296	47.30	0.45	47.75	60.37	12.62	
	0.471	41.18	0.51	41.69	56.49	14.80	
	0.743	37.89	0.52	38.41	56.00	17.59	
	8.592	42.61	0.99	43.60	60.00	16.40	
	19.326	43.28	1.57	44.85	60.00	15.15	
	0.150	42.35	0.37	42.72	56.00	13.28	AV
	0.296	31.23	0.45	31.68	50.37	18.69	
	0.471	31.24	0.51	31.75	46.49	14.74	
	0.743	21.42	0.52	21.94	46.00	24.06	
	8.592	31.27	0.99	32.26	50.00	17.74	
	19.326	33.21	1.57	34.78	50.00	15.22	
Neutral	0.150	52.15	0.32	52.47	66.00	13.53	QP
	0.297	46.53	0.39	46.92	60.32	13.40	
	0.471	40.46	0.48	40.94	56.49	15.55	
	8.592	42.86	0.95	43.81	60.00	16.19	
	19.326	42.69	1.73	44.42	60.00	15.58	
	27.708	43.55	1.91	45.46	60.00	14.54	
	0.150	42.35	0.32	42.67	56.00	13.33	AV
	0.297	31.24	0.39	31.63	50.32	18.69	
	0.471	31.26	0.48	31.74	46.49	14.75	
	8.592	31.25	0.95	32.20	50.00	17.80	
	19.326	31.24	1.73	32.97	50.00	17.03	
	27.708	31.25	1.91	33.16	50.00	16.84	

TEST ENGINEER: WENCY YANG

EUT : LCD TV Temperature : 22°C

Model No. : LEDN24K15PAM Humidity : 48%RH

Serial No. : E2010092801 Date of Test : Oct 13, 2010

Test Mode : HDMI 1280*1024@60Hz

Test Line	Frequency (MHz)	Meter Reading dB(μ V)	Factor (dB)	Emission Level dB(μ V)	Limits dB(μ V)	Margin (dB)	Remark
Line	0.150	51.22	0.37	51.59	66.00	14.41	QP
	0.297	45.27	0.45	45.72	60.32	14.60	
	0.471	39.08	0.51	39.59	56.49	16.90	
	8.592	42.18	0.99	43.17	60.00	16.83	
	19.532	41.66	1.58	43.24	60.00	16.76	
	27.416	42.69	1.85	44.54	60.00	15.46	
	0.150	41.23	0.37	41.60	56.00	14.40	AV
	0.297	32.13	0.45	32.58	50.32	17.74	
	0.471	28.51	0.51	29.02	46.49	17.47	
	8.592	31.27	0.99	32.26	50.00	17.74	
	19.532	31.28	1.58	32.86	50.00	17.14	
	27.416	31.27	1.85	33.12	50.00	16.88	
Neutral	0.150	52.19	0.32	52.51	66.00	13.49	QP
	0.297	46.49	0.39	46.88	60.32	13.44	
	0.476	41.10	0.48	41.58	56.41	14.83	
	8.501	43.22	0.95	44.17	60.00	15.83	
	19.224	41.89	1.73	43.62	60.00	16.38	
	27.708	42.40	1.91	44.31	60.00	15.69	
	0.150	41.23	0.32	41.55	56.00	14.45	AV
	0.297	31.25	0.39	31.64	50.32	18.68	
	0.476	31.26	0.48	31.74	46.41	14.67	
	8.501	33.24	0.95	34.19	50.00	15.81	
	19.224	30.27	1.73	32.00	50.00	18.00	
	27.708	31.77	1.91	33.68	50.00	16.32	

TEST ENGINEER: WENCY YANG

4 RADIATED EMISSION TEST

4.1 Test Equipment

The following test equipments are used during the radiated emission test in a semi-anechoic chamber:

Item	Type	Manufacturer	Model No.	Serial No.	Last Cal.	Next Cal.
1.	Test Receiver	R&S	ESVS10	844594/001	Mar 07, 2010	Mar 07, 2011
2.	Preamplifier	Agilent	8447D	2944A10548	Sep 19, 2010	Mar 19, 2011
3.	Preamplifier	HP	8449B	3008A00864	Apr 29, 2010	Apr 29, 2011
4.	Bi-log Antenna	TESEQ	CBL6112D	23192	Dec 01, 2009	Dec 01, 2010
5.	Spectrum Analyzer	Agilent	E7405A	MY45106600	May 19, 2010	May 19, 2011
6.	Software	Audix	E3	SET00200 9912M295-2	--	--

4.2 Block Diagram of Test Setup

4.2.1 EUT and Peripherals

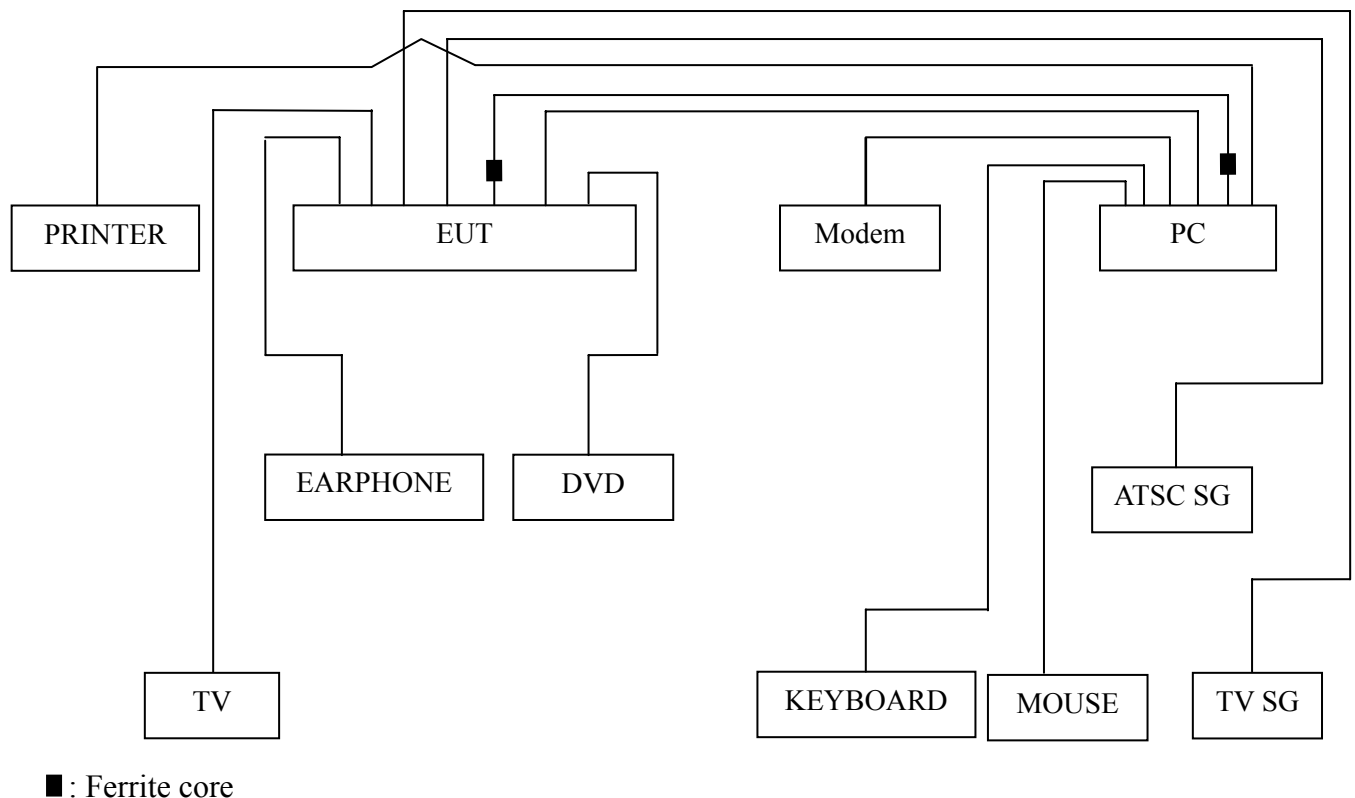

4.2.2 Radiated emission test setup

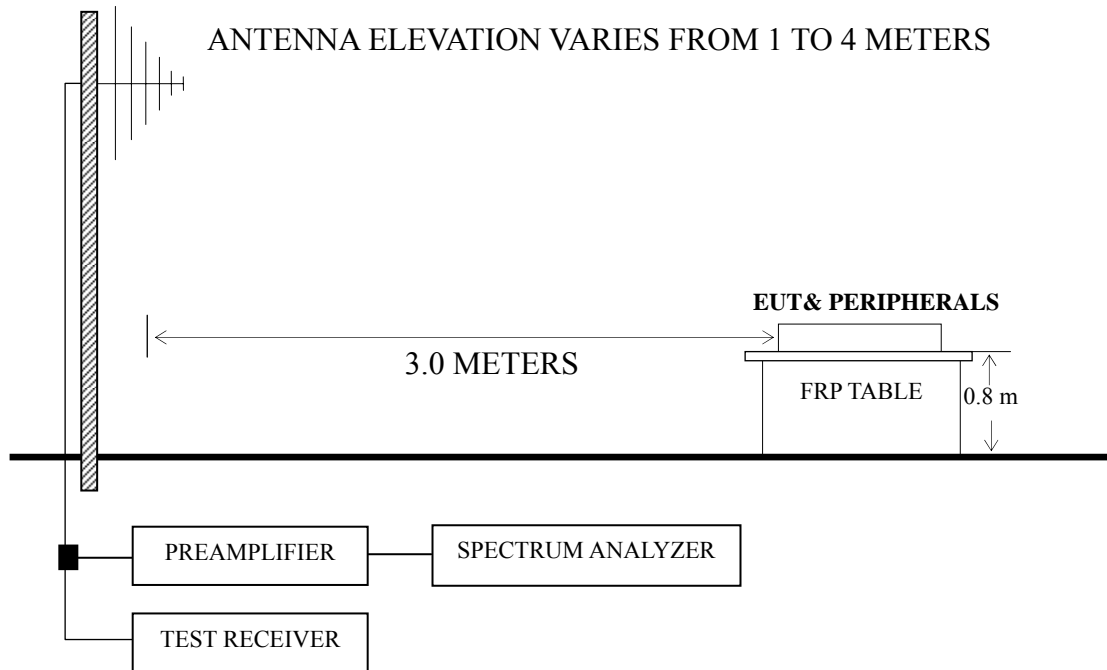

■ : 50 ohm Coaxial Switch

4.3 Radiated Emission Limit [FCC Part 15 Subpart B 15.109(a)]

Frequency (MHz)	Distance (m)	Field strength limits	
		($\mu\text{V}/\text{m}$)	dB ($\mu\text{V}/\text{m}$)
30 ~ 88	3	100	40.0
88 ~ 216	3	150	43.5
216 ~ 960	3	200	46.0
Above 960	3	500	54.0

NOTE 1 - Emission Level dB ($\mu\text{V}/\text{m}$) = 20 log Emission Level ($\mu\text{V}/\text{m}$)

NOTE 2 - The tighter limit applies at the band edges.

NOTE 3 - Distance refers to the distance in meters between the measuring instrument antenna and the closed point of any part of the device or system.

NOTE 4 - The limits shown are based on Quasi-peak value detector below or equal to 1GHz and Average value detector above 1GHz.

NOTE 5 - Above 1 GHz, the limit on peak emission is 20 dB above the maximum permitted average emission limit applicable to the EUT.

4.4 Test Configuration

The configuration of the EUT and peripherals are same as those used in conducted emission test.

Please refer to Sec.3.4.

4.5 Operating Condition of EUT

Same as conducted emission test which is listed in Sec.3.5, except for the test setup replaced by Sec.4.2.

4.6 Test Procedures

The EUT and peripherals were placed on a FRP turntable that is 0.8 meter above ground. The FRP turntable rotated 360 degrees to determine the position of the maximum emission level. The EUT was set 3 meters away from the receiving antenna, which was mounted on an antenna tower. Broadband antenna (Calibrated Bilog Antenna) was used as receiving antenna. The antenna moved up and down between 1 meter and 4 meters to find out the maximum emission level. Both horizontal and vertical polarizations of the antenna were set on measurement. In order to find the maximum emission, all of the interference cables were manipulated according to ANSI C63.4:2003 requirements during radiated emission test.

The I.F. bandwidth of Test Receiver R&S ESVS10 was set at 120 kHz below 1GHz and The Spectrum Agilent E7405A was set at 1MHz above 1GHz.

The frequency range from 30 MHz to 1000MHz was checked for all test modes.

The frequency range from 1 GHz to 2 GHz was checked for D-Sub/HDMI 1280*1024@60Hz mode.

The test modes were done on radiated disturbance test and all the test results are listed in Sec.4.7.

4.7 Test Results

<PASS>

The frequency and amplitude of the highest radiated emission relative the limit is reported. All the emissions not reported below are too low against the FCC limit.

Test Mode	Data Page
D-Sub 640*480@60Hz	P23
D-Sub 800*600@60Hz	P24
D-Sub 1280*1024@60Hz	P25 – P26
HDMI 640*480@60Hz	P27
HDMI 800*600@60Hz	P28
HDMI 1280*1024@60Hz	P29 – P30

- NOTE 1 – Emission Level = Antenna Factor + Cable Loss + Meter Reading. (< 1GHz)
- NOTE 2 – Emission Level = Antenna Factor + Cable Loss – Preamp Factor + Meter Reading. (> 1GHz)
- NOTE 3 – All readings are Quasi-Peak values below or equal to 1GHz, Peak and Average values above 1GHz.
- NOTE 4 – The emission levels that are 20dB below the official limit are not reported.
- NOTE 5 – 0° was the table front facing the antenna. Degree is calculated from 0° clockwise facing the antenna.
- NOTE 6 – The worst case is for D-Sub 640*480@60Hz test mode. The worst emission at horizontal polarization was detected at 405.390 MHz with corrected signal level of 37.41 dB ($\mu\text{V}/\text{m}$) (limit is 46.00 dB ($\mu\text{V}/\text{m}$)), when the antenna was 1.00 m height and the turntable was at 70°. The worst emission at vertical polarization was detected at 542.160 MHz with corrected signal level of 41.59 dB ($\mu\text{V}/\text{m}$) (limit is 46.00 dB ($\mu\text{V}/\text{m}$)), when the antenna was 1.00 m height and the turntable was at 275°.

EUT : LCD TV Temperature : 22°C

Model No. : LEDN24K15PAM Humidity : 60%RH

Serial No. : E2010092801 Date of Test : Oct 18, 2010

Test Mode : D-Sub 640*480@60Hz

Polarization	Frequency (MHz)	Meter Reading dB (μV)	Antenna Factor (dB/m)	Cable Loss (dB)	Emission Level dB (μV/m)	Limits dB (μV/m)	Margin (dB)
Horizontal	59.100	6.80	0.83	19.95	27.58	40.00	12.42
	153.190	11.04	1.25	18.01	30.30	43.50	13.20
	202.660	10.81	1.46	16.97	29.24	43.50	14.26
	333.610	14.86	1.87	10.75	27.48	46.00	18.52
	405.390	16.57	2.08	18.76	37.41	46.00	8.59
	541.190	18.45	2.33	12.95	33.73	46.00	12.27
Vertical	84.320	8.48	0.96	25.95	35.39	40.00	4.61
	108.570	12.17	1.08	23.20	36.45	43.50	7.05
	161.920	10.46	1.29	22.33	34.08	43.50	9.42
	361.740	15.65	1.96	12.94	30.55	46.00	15.45
	405.390	16.57	2.08	21.53	40.18	46.00	5.82
	542.160	18.45	2.35	20.79	41.59	46.00	4.41

TEST ENGINEER: RAVEN JIN

EUT : LCD TV Temperature : 22°C

Model No. : LEDN24K15PAM Humidity : 60%RH

Serial No. : E2010092801 Date of Test : Oct 18, 2010

Test Mode : D-Sub 800*600@60Hz

Polarization	Frequency (MHz)	Meter Reading dB (μ V)	Antenna Factor (dB/m)	Cable Loss (dB)	Emission Level dB (μ V/m)	Limits dB (μ V/m)	Margin (dB)
Horizontal	173.560	10.09	1.35	24.08	35.52	43.50	7.98
	253.100	12.97	1.61	16.22	30.80	46.00	15.20
	385.990	16.20	2.02	9.76	27.98	46.00	18.02
	523.730	18.21	2.30	17.97	38.48	46.00	7.52
	729.370	20.00	2.75	7.36	30.11	46.00	15.89
	855.470	21.28	2.97	16.05	40.30	46.00	5.70
Vertical	58.130	6.96	0.83	22.70	30.49	40.00	9.51
	66.860	6.53	0.88	23.67	31.08	40.00	8.92
	166.770	10.31	1.31	26.94	38.56	43.50	4.94
	203.630	10.85	1.46	25.43	37.74	43.50	5.76
	324.880	14.58	1.84	15.92	32.34	46.00	13.66
	520.820	18.18	2.30	18.08	38.56	46.00	7.44

TEST ENGINEER: RAVEN JIN

EUT : LCD TV Temperature : 22°C

Model No. : LEDN24K15PAM Humidity : 60%RH

Serial No. : E2010092801 Date of Test : Oct 18, 2010

Test Mode : D-Sub 1280*1024@60Hz

Polarization	Frequency (MHz)	Meter Reading dB (μV)	Antenna Factor (dB/m)	Cable Loss (dB)	Preamp Factor (dB)	Emission Level dB (μV/m)	Limits dB (μV/m)	Margin (dB)	Remark
Horizontal	53.280	18.56	8.14	0.80	--	27.50	40.00	12.50	QP
	163.860	26.45	10.40	1.30	--	38.15	43.50	5.35	
	200.720	26.04	10.74	1.45	--	38.23	43.50	5.27	
	405.390	19.80	16.57	2.08	--	38.45	46.00	7.55	
	523.730	18.57	18.21	2.30	--	39.08	46.00	6.92	
	923.370	15.26	21.87	3.22	--	40.35	46.00	5.65	
	1024.000	50.69	22.57	4.49	37.36	40.39	74.00	33.61	PK
	1149.000	50.56	23.42	4.51	37.11	41.38	74.00	32.62	
	1234.000	49.95	23.98	4.52	36.93	41.52	74.00	32.48	
	1399.000	49.92	25.20	4.54	36.54	43.12	74.00	30.88	
	1597.000	48.32	26.36	4.56	36.10	43.14	74.00	30.86	
	1762.000	46.40	26.81	4.58	35.86	41.93	74.00	32.07	
	1024.000	41.69	22.57	4.49	37.36	31.39	54.00	22.61	AV
	1149.000	38.56	23.42	4.51	37.11	29.38	54.00	24.62	
	1234.000	37.95	23.98	4.52	36.93	29.52	54.00	24.48	
	1399.000	36.92	25.20	4.54	36.54	30.12	54.00	23.88	
	1597.000	34.32	26.36	4.56	36.10	29.14	54.00	24.86	
	1762.000	34.40	26.81	4.58	35.86	29.93	54.00	24.07	

TEST ENGINEER: RAVEN JIN

EUT : LCD TV Temperature : 22°C

Model No. : LEDN24K15PAM Humidity : 60%RH

Serial No. : E2010092801 Date of Test : Oct 18, 2010

Test Mode : D-Sub 1280*1024@60Hz

Polarization	Frequency (MHz)	Meter Reading dB (μV)	Antenna Factor (dB/m)	Cable Loss (dB)	Preamp Factor (dB)	Emission Level dB (μV/m)	Limits dB (μV/m)	Margin (dB)	Remark
Vertical	33.880	16.40	17.44	0.67	--	34.51	40.00	5.49	QP
	106.630	21.12	12.02	1.07	--	34.21	43.50	9.29	
	173.560	17.64	10.09	1.35	--	29.08	43.50	14.42	
	253.100	13.38	12.97	1.61	--	27.96	46.00	18.04	
	405.390	14.47	16.57	2.08	--	33.12	46.00	12.88	
	521.790	15.88	18.18	2.30	--	36.36	46.00	9.64	
	1024.000	47.46	22.57	4.49	37.36	37.16	74.00	36.84	PK
	1194.000	46.82	23.67	4.51	37.02	37.98	74.00	36.02	
	1394.000	45.46	25.16	4.54	36.55	38.61	74.00	35.39	
	1597.000	44.27	26.36	4.56	36.10	39.09	74.00	34.91	
	1732.000	44.08	26.74	4.57	35.90	39.49	74.00	34.51	
	1879.000	43.35	27.35	4.67	35.72	39.65	74.00	34.35	
	1024.000	37.46	22.57	4.49	37.36	27.16	54.00	26.84	AV
	1194.000	34.82	23.67	4.51	37.02	25.98	54.00	28.02	
	1394.000	32.46	25.16	4.54	36.55	25.61	54.00	28.39	
	1597.000	29.27	26.36	4.56	36.10	24.09	54.00	29.91	
	1732.000	29.08	26.74	4.57	35.90	24.49	54.00	29.51	
	1879.000	30.35	27.35	4.67	35.72	26.65	54.00	27.35	

TEST ENGINEER: RAVEN JIN

EUT : LCD TV Temperature : 22°C

Model No. : LEDN24K15PAM Humidity : 60%RH

Serial No. : E2010092801 Date of Test : Oct 18, 2010

Test Mode : HDMI 640*480@60Hz

Polarization	Frequency (MHz)	Meter Reading dB (μ V)	Antenna Factor (dB/m)	Cable Loss (dB)	Emission Level dB (μ V/m)	Limits dB (μ V/m)	Margin (dB)
Horizontal	59.100	26.95	6.80	0.83	34.58	40.00	5.42
	108.570	18.07	12.17	1.08	31.32	43.50	12.18
	153.190	26.01	11.04	1.25	38.30	43.50	5.20
	202.660	25.97	10.81	1.46	38.24	43.50	5.26
	405.390	22.76	16.57	2.08	41.41	46.00	4.59
	541.190	15.95	18.45	2.33	36.73	46.00	9.27
Vertical	33.880	12.96	17.44	0.67	31.07	40.00	8.93
	59.100	21.68	6.80	0.83	29.31	40.00	10.69
	108.570	15.20	12.17	1.08	28.45	43.50	15.05
	162.890	13.76	10.42	1.30	25.48	43.50	18.02
	405.390	15.53	16.57	2.08	34.18	46.00	11.82
	542.160	13.79	18.45	2.35	34.59	46.00	11.41

TEST ENGINEER: RAVEN JIN

EUT : LCD TV Temperature : 22°C

Model No. : LEDN24K15PAM Humidity : 60%RH

Serial No. : E2010092801 Date of Test : Oct 18, 2010

Test Mode : HDMI 800*600@60Hz

Polarization	Frequency (MHz)	Meter Reading dB (μ V)	Antenna Factor (dB/m)	Cable Loss (dB)	Emission Level dB (μ V/m)	Limits dB (μ V/m)	Margin (dB)
Horizontal	33.880	15.40	17.44	0.67	33.51	40.00	6.49
	53.280	25.23	8.14	0.80	34.17	40.00	5.83
	106.630	14.70	12.02	1.07	27.79	43.50	15.71
	385.990	12.76	16.20	2.02	30.98	46.00	15.02
	523.730	10.97	18.21	2.30	31.48	46.00	14.52
	596.480	13.32	19.17	2.44	34.93	46.00	11.07
Vertical	58.130	24.70	6.96	0.83	32.49	40.00	7.51
	66.860	24.67	6.53	0.88	32.08	40.00	7.92
	203.630	22.43	10.85	1.46	34.74	43.50	8.76
	405.390	16.20	16.57	2.08	34.85	46.00	11.15
	520.820	17.08	18.18	2.30	37.56	46.00	8.44
	923.370	13.30	21.87	3.22	38.39	46.00	7.61

TEST ENGINEER: RAVEN JIN

EUT : LCD TV Temperature : 22°C

Model No. : LEDN24K15PAM Humidity : 60%RH

Serial No. : E2010092801 Date of Test : Oct 18, 2010

Test Mode : HDMI 1280*1024@60Hz

Polarization	Frequency (MHz)	Meter Reading dB (μV)	Antenna Factor (dB/m)	Cable Loss (dB)	Preamp Factor (dB)	Emission Level dB (μV/m)	Limits dB (μV/m)	Margin (dB)	Remark
Horizontal	66.860	25.10	6.53	0.88	--	32.51	40.00	7.49	QP
	146.400	19.12	11.61	1.23	--	31.96	43.50	11.54	
	163.860	25.45	10.40	1.30	--	37.15	43.50	6.35	
	323.910	20.11	14.58	1.84	--	36.53	46.00	9.47	
	405.390	21.80	16.57	2.08	--	40.45	46.00	5.55	
	523.730	20.57	18.21	2.30	--	41.08	46.00	4.92	
	1024.000	54.69	22.57	4.49	37.36	44.39	74.00	29.61	PK
	1149.000	54.56	23.42	4.51	37.11	45.38	74.00	28.62	
	1294.000	53.92	24.45	4.53	36.80	46.10	74.00	27.90	
	1444.000	54.16	25.45	4.55	36.42	47.74	74.00	26.26	
	1597.000	52.32	26.36	4.56	36.10	47.14	74.00	26.86	
	1762.000	50.40	26.81	4.58	35.86	45.93	74.00	28.07	
	1024.000	43.69	22.57	4.49	37.36	33.39	54.00	20.61	AV
	1149.000	41.56	23.42	4.51	37.11	32.38	54.00	21.62	
	1294.000	39.92	24.45	4.53	36.80	32.10	54.00	21.90	
	1444.000	39.16	25.45	4.55	36.42	32.74	54.00	21.26	
	1597.000	37.32	26.36	4.56	36.10	32.14	54.00	21.86	
	1762.000	36.40	26.81	4.58	35.86	31.93	54.00	22.07	

TEST ENGINEER: RAVEN JIN

EUT : LCD TV Temperature : 22°C

Model No. : LEDN24K15PAM Humidity : 60%RH

Serial No. : E2010092801 Date of Test : Oct 18, 2010

Test Mode : HDMI 1280*1024@60Hz

Polarization	Frequency (MHz)	Meter Reading dB (μV)	Antenna Factor (dB/m)	Cable Loss (dB)	Preamp Factor (dB)	Emission Level dB (μV/m)	Limits dB (μV/m)	Margin (dB)	Remark
Vertical	33.880	15.40	17.44	0.67	--	33.51	40.00	6.49	QP
	53.280	25.58	8.14	0.80	--	34.52	40.00	5.48	
	66.860	21.93	6.53	0.88	--	29.34	40.00	10.66	
	106.630	18.12	12.02	1.07	--	31.21	43.50	12.29	
	521.790	17.88	18.18	2.30	--	38.36	46.00	7.64	
	855.470	14.41	21.28	2.97	--	38.66	46.00	7.34	
	1024.000	54.46	22.57	4.49	37.36	44.16	74.00	29.84	PK
	1127.000	52.99	23.27	4.50	37.15	43.61	74.00	30.39	
	1314.000	52.09	24.62	4.53	36.75	44.49	74.00	29.51	
	1444.000	53.53	25.45	4.55	36.42	47.11	74.00	26.89	
	1597.000	51.27	26.36	4.56	36.10	46.09	74.00	27.91	
	1762.000	51.44	26.81	4.58	35.86	46.97	74.00	27.03	
	1024.000	41.46	22.57	4.49	37.36	31.16	54.00	22.84	AV
	1127.000	39.99	23.27	4.50	37.15	30.61	54.00	23.39	
	1314.000	38.09	24.62	4.53	36.75	30.49	54.00	23.51	
	1444.000	40.52	25.45	4.55	36.42	34.11	54.00	19.89	
	1597.000	38.27	26.36	4.56	36.10	33.09	54.00	20.91	
	1762.000	36.44	26.81	4.58	35.86	31.97	54.00	22.03	

TEST ENGINEER: RAVEN JIN

5 DEVIATION TO TEST SPECIFICATIONS

None.

6 DEBUG DESCRIPTION

The following components are used during the countermeasure procedures:

Name	M/N	Manufacturer	Location
Ferrite core	ZCAT2132-1130\ROH	FEELUX	See Internal Photos Figure 15
		Rui Feng Electronic Co., Ltd.	
		Hai An Magnetic Material No.2 Factory	
		JIANGSU LETTALL ELECTRONICS CO., LTD.	
Conductive foam	DAA1002\ROH	Qingdao Joinset S&T Co., Ltd.	See Internal Photos Figure 16
		TAT ELECTRONIC TECH CO.,LTD.	

Note: We had required the applicant and manufacturer that all electrical and mechanical devices employed for spurious radiation suppression, including any modifications made during certification testing, must be incorporated in each unit marked

TEST ENGINEER:

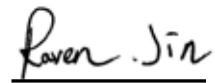

(RAVEN JIN)