

Application for FCC Certificate
On Behalf of
Hisense Electric Co., Ltd.

LCD TV

Model No.	Serial No.	Brand
LTDN24V86US	E2009102101	Hisense
LTDN24V68US	--	
NX2403	--	NEXUS

FCC ID : W9HLCDA0003

Prepared For : Hisense Electric Co., Ltd.
No.218 Qianwangang Road, Economy & Technology
Development Zone, Qingdao, China

Prepared By : Audix Technology (Shanghai) Co., Ltd.
3F 34Bldg 680 Guiping Rd,
Caohejing Hi-Tech Park,
Shanghai 200233, China

Tel: +86-21-64955500
Fax: +86-21-64955491

Report No. : ACI-F10003
Date of Test : Jan 04-05, 2010
Date of Report : Jan 07, 2010

TABLE OF CONTENTS

	Page
1 SUMMARY OF STANDARDS AND RESULTS	4
1.1 Description of Standards and Results.....	4
2 GENERAL INFORMATION	5
2.1 Description of Equipment Under Test.....	5
2.2 Peripherals.....	6
2.3 Description of Test Facility.....	8
2.4 Measurement Uncertainty.....	8
3 CONDUCTED EMISSION TEST	9
3.2 Block Diagram of Test Setup.....	9
3.3 Conducted Emission Limit [FCC Part 15 Subpart B 15.107(a)].....	10
3.4 Test Configuration.....	10
3.5 Operating Condition of EUT.....	11
3.6 Test Procedures.....	11
3.7 Test Results.....	12
4 RADIATED EMISSION TEST	19
4.1 Test Equipment.....	19
4.2 Block Diagram of Test Setup.....	19
4.3 Radiated Emission Limit [FCC Part 15 Subpart B 15.109(a)].....	20
4.4 Test Configuration.....	20
4.5 Operating Condition of EUT.....	20
4.6 Test Procedures.....	21
4.7 Test Results.....	21
5 DEVIATION TO TEST SPECIFICATIONS	28
6 DEBUG DESCRIPTION	29

TEST REPORT FOR FCC CERTIFICATE

Applicant : Hisense Electric Co., Ltd.
 Manufacturer : Hisense Electric Co., Ltd.
 EUT Description : LCD TV

Model No.	Serial No.	Brand	Power Supply
LTDN24V86US	E2009102101	Hisense	120V/60Hz
LTDN24V68US	--		
NX2403	--	NEXUS	

Test Procedure Used:

*FCC RULES AND REGULATIONS PART 15 SUBPART B CLASS B OCTOBER 2008
AND ANSI C63.4-2003*

The device described above is tested by Audix Technology (Shanghai) Co., Ltd. to determine the maximum emission levels emanating from the device. The maximum emission levels are compared to the FCC Part 15 Subpart B (Class B) limits both radiated and conducted emissions.

The test results are contained in this test report and Audix Technology (Shanghai) Co., Ltd. is assumed full responsibility for the accuracy and completeness of these measurements. This report shows that the EUT (M/N: Refer to Sec.2.1; S/N: Refer to Sec.2.1) which was tested in 3m anechoic chamber Dec 24-25, 2009 is technically compliance with the FCC official limits also.

This report applies to above tested sample only. This report shall not be reproduced in part without written approval of Audix Technology (Shanghai) Co., Ltd.

This report contains data that are not covered by the NVLAP accreditation.

This report must not be used by the client to claim product certification, approval, or endorsement by NVLAP, NIST, or any agency of the federal government.

The test results for EUT's TV functions are contained in No.F10002, a Verification report.

Date of Test : Jan 04-05, 2010 Date of Report : Jan 07, 2010

Producer : Alan He
ALAN HE / Assistant

Review : Dio Yang
DIO YANG / Deputy Assistant Manager

AUDIX® For and on behalf of
Audix Technology (Shanghai) Co., Ltd.

Signatory : Sammy Chen
Authorized Signature EMC SAMMY CHEN / Assistant Manager

1 SUMMARY OF STANDARDS AND RESULTS

1.1 Description of Standards and Results

The EUT have been tested according to the applicable standards as referenced below:

Description of Test Item	Standard	Limits	Results
EMISSION			
Conducted Disturbance at the Mains Terminal	FCC RULES AND REGULATIONS PART 15 SUBPART B OCTOBER 2008 AND ANSI C63.4-2003	15.107(a) Class B	Pass
Radiated Disturbance	FCC RULES AND REGULATIONS PART 15 SUBPART B OCTOBER 2008 AND ANSI C63.4-2003	15.109(a) Class B	Pass

2 GENERAL INFORMATION

2.1 Description of Equipment Under Test

Description : LCD TV

Type of EUT : Production Pre-product Pro-type

Model No.	Serial No.	Brand
LTDN24V86US	E2009102101	Hisense
LTDN24V68US	--	
NX2403	--	NEXUS

Note 1 : The above models are all the same except for the different model number and brand.

Note 2 : The LTDN24V86US was tested and recorded in this report.

Applicant : Hisense Electric Co., Ltd.
No.218 Qianwangang Road, Economy & Technology Development Zone, Qingdao, China

Manufacturer : Hisense Electric Co., Ltd.
No.218 Qianwangang Road, Economy & Technology Development Zone, Qingdao, China

LCD Panel : Manufacturer : CHI MEI OPTOELECTRONICS
M/N : V236H1-L01

Max Resolution : 1024*768@60Hz

D-Sub Cable : Shielded, Detachable, 1.85m,
with two cores on cable

HDMI Cable : Shielded, Detachable, 1.85m,
without core on cable

Power Cord : Unshielded, Detachable, 1.80m

Remark:

The EUT is a LCD TV which input/output ports as follows:

Side View:

(1) One COAXIAL Port

Connected with DVD

(2) One Headphone Port

Connected with Earphone

Bottom View:

(3)	One ANT Port	Connected with TV SG / ATSC SG
(4)	One S-Video Port	Connected with TV SG
(5)	One component of AV Port	Connected with DVD
(6)	One component of YPbPr Port	Connected with DVD
(7)	One VGA Port	Connected with PC
(8)	One VGA Audio Port	Connected with PC
(9)	One HDMI Port	Connected with PC/DVD
(10)	One Service Port	Do not open to Customer

2.2 Peripherals

2.2.1 PC

Manufacturer : HP
 Model Number : dx7400MT
 Serial Number : CNG8130K89
 Power Cord : Unshielded, Detachable, 1.8m
 Certificate : FCC DoC; CE/EMC; VCCI; C-Tick; UL
 BSMI (R33001) 3C (A000111)
 MIC (E-A011-04-2659(B))

2.2.2 Printer

Manufacturer : HP
 Model Number : C3990A
 Serial Number : JPZX020487
 Data Cable : Shielded, detachable, 1.5m
 Certificate : GS, CE/EMC, C-Tick, FCC DoC

2.2.3 Keyboard

Manufacturer : Microsoft
 Model Number : RT2300
 Serial Number : 7668200662248
 Data Cable : Shielded, undetachable, 1.8m
 Certificate : CE/EMC, FCC DoC, VCCI, MIC, C-Tick, BSMI

2.2.4 Mouse

Manufacturer : Microsoft
 Model Number : RT2300
 Serial Number : 6965712071551
 Data Cable : Shielded, undetachable, 1.8m.
 Certificate : CE/EMC, FCC DoC, VCCI, MIC, C-Tick, BSMI

2.2.5 Modem

Manufacturer : TP-LINK
Model Number : TM-EC5658V
Serial Number : 07123301053
Data Cable : Shielded, Detachable, 1.8m
Certificate : FCC DoC, CE/EMC, CCC

2.2.6 Earphone

Manufacturer : SONY
Model Number : MDR-E808
Serial Number : 1808030805305506

2.2.7 TV Signal Generator

Manufacturer : FLUKE
Model Number : 54200m01
Serial Number : 814008
Data Cable : Shielded, detachable, 2.0m
Power Cord : Unshielded, detachable, 2.0m
Certificate : CE/EMC, FCC DoC, CCC

2.2.8 ATSC Signal Generator

Manufacturer : SENCORE
Model Number : ATSC997
Serial Number : 6790071

2.2.9 DVD

Manufacturer : PHILIPS
Model Number : DVP3986K/93
Serial Number : KX1A0902120108
Certificate : FCC DoC, CE/EMC, CCC

2.3 Description of Test Facility

Site Description (Semi-Anechoic Chamber) : Sept. 17, 1998 file on
Apr 29, 2009 Renewed
Federal Communications Commission
FCC Engineering Laboratory
7435 Oakland Mills Road
Columbia, MD 21046, USA

Name of Firm : Audix Technology (Shanghai) Co., Ltd.

Site Location : 3F 34Bldg 680 Guiping Rd,
Caohejing Hi-Tech Park,
Shanghai 200233, China

NVLAP Lab Code : 200371-0

2.4 Measurement Uncertainty

Conducted Emission Expanded Uncertainty: U = 1.26 dB
Radiated Emission Expanded Uncertainty : U = 3.02 dB

3 CONDUCTED EMISSION TEST

3.1.1 Test Equipment

The following test equipments are used during the conducted emission test in a shielded room:

Item	Type	Manufacturer	Model No.	Serial No.	Last Cal.	Next Cal.
1.	Test Receiver	R&S	ESCI	100841	Oct 15, 2009	Oct 15, 2010
2.	Artificial Mains Network (AMN)	R&S	ESH2-Z5	843890/011	Apr 02, 2009	Apr 02, 2010
3.	Line Impedance Stabilization Network (LISN)	Kyoritsu	KNW-407	8-1280-4	Apr 02, 2009	Apr 02, 2010
4.	50 Ω Coaxial Switch	Anritsu	MP59B	6200426389	Sep 19, 2009	Mar 19, 2010
5.	50 Ω Terminator	Anritsu	BNC	001	Apr 02, 2009	Apr 02, 2010
6.	Software	Audix	E3	SET00200 9804M592	--	--

3.2 Block Diagram of Test Setup

3.2.1 EUT & Peripherals

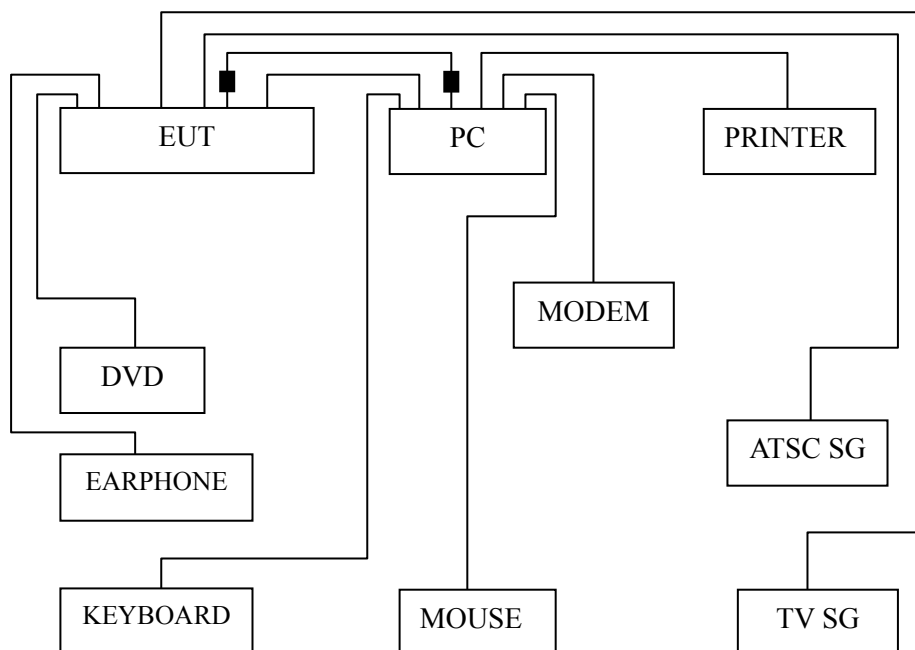

■ : Ferrite core

3.2.2 Conducted Disturbance Test Setup

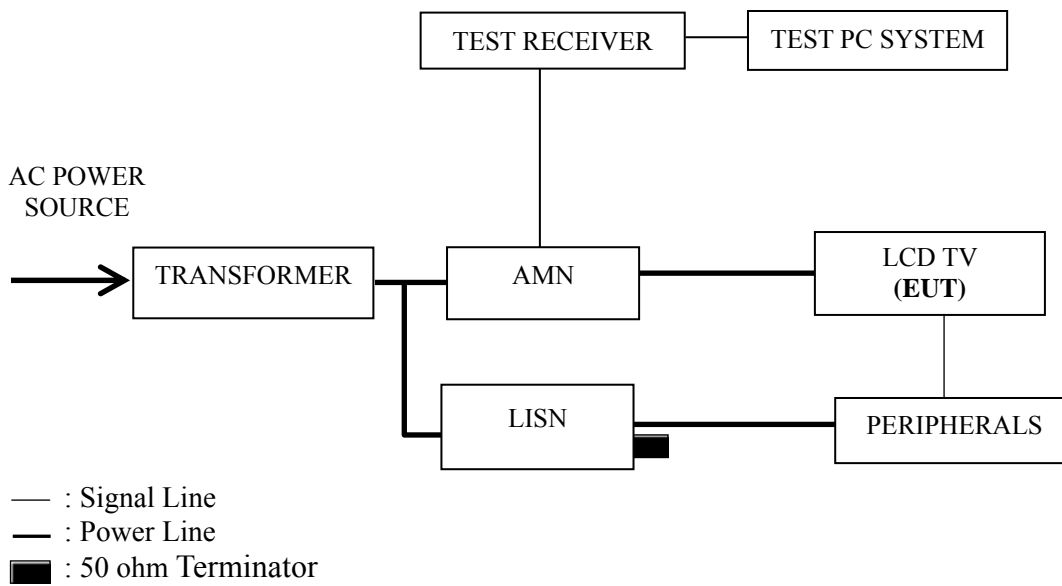

3.3 Conducted Emission Limit [FCC Part 15 Subpart B 15.107(a)]

Frequency Range (MHz)	Limits dB (μ V)	
	Quasi-peak	Average
0.15 ~ 0.5	66~56	56~46
0.5 ~ 5	56	46
5 ~ 30	60	50

NOTE 1 – The lower limit shall apply at the transition frequencies.
 NOTE 2 – The limit decreases linearly with the logarithm of the frequency in the range 0.15 MHz~0.50 MHz

3.4 Test Configuration

The EUT (listed in Sec.2.1) and the peripherals (listed in Sec 2.2) were installed as shown on Sec.3.2 to meet FCC requirement and operating in a manner that tends to maximize its emission level in a normal application.

3.5 Operating Condition of EUT

3.5.1 Setup the EUT and peripherals as shown in Sec. 3.2.

3.5.2 Turn on the power of all equipments and the EUT.

3.5.3 Set the contrast & brightness of EUT to maximum.

3.5.4 PC system ran the self-test program “EMC Test” by windows XP and sent “H” characters to EUT through graphic card, the EUT’s screen displayed and filled with “H” pattern by its resolution (Via D-Sub & HDMI Input).

3.5.5 Repeat above procedure from 3.5.3 to 3.5.4 for difference test mode.

3.5.6 The other peripherals devices were driven and operated during the test.

3.5.7 The test modes are as follows:

Test Mode
D-Sub 640*480@60Hz
D-Sub 800*600@60Hz
D-Sub 1024*768@60Hz
HDMI 640*480@60Hz
HDMI 800*600@60Hz
HDMI 1024*768@60Hz

3.6 Test Procedures

The EUT and peripherals were connected to the power mains through an Artificial Mains Network (AMN). This provided a 50 ohm coupling impedance for the measuring equipment.

Both sides of AC line (Line & Neutral) were checked for maximum conducted interference. In order to find the maximum emission, the relative positions of equipment and all of the interface cables were changed or manipulated according to ANSI C63.4:2003 during conducted emission test.

The bandwidth of R&S Test Receiver ESCI was set at 9 kHz.

The frequency range from 150 kHz to 30 MHz was checked.

The test modes were done on conducted disturbance test and all the test results are listed in Sec. 3.7.

3.7 Test Results

< **PASS** >

The frequency and amplitude of the highest conducted emission relative to the limit is reported. All emissions not reported below are too low against the prescribed limits.

Test Mode	Data Page
D-Sub 640*480@60Hz	P13
D-Sub 800*600@60Hz	P14
D-Sub 1024*768@60Hz	P15
HDMI 640*480@60Hz	P16
HDMI 800*600@60Hz	P17
HDMI 1024*768@60Hz	P18

NOTE 1 – Factor = Cable Loss + AMN Factor.

NOTE 2 – Emission Level = Meter Reading + Factor.

NOTE 3 – “QP” means “Quasi-Peak” values, “AV” means “Average” values.

NOTE 4 – The worst case is for D-Sub 640*480@60Hz test mode. The worst emission is detected at 1.577 MHz (Average Value) with corrected signal level of 40.56 dB (μV) (limit is 46.00 dB (μV)), when the Neutral of the EUT is connected to AMN.

EUT : LCD TV Temperature : 22°C

Model No. : LTDN24V86US Humidity : 48%RH

Serial No. : E2009102101 Date of Test : Jan 04, 2010

Test Mode : D-Sub 640*480@60Hz

Test Line	Frequency (MHz)	Meter Reading dB(μ V)	Factor (dB)	Emission Level dB(μ V)	Limits dB(μ V)	Margin (dB)	Remark
Line	0.150	45.28	0.23	45.51	66.00	20.49	QP
	0.199	41.97	0.22	42.19	63.66	21.47	
	1.464	35.69	0.34	36.03	56.00	19.97	
	2.356	32.47	0.37	32.84	56.00	23.16	
	5.606	32.78	0.45	33.23	60.00	26.77	
	10.310	36.85	0.51	37.36	60.00	22.64	
	0.150	31.26	0.23	31.49	56.00	24.51	AV
	0.199	32.75	0.22	32.97	53.66	20.69	
	1.464	25.63	0.34	25.97	46.00	20.03	
	2.356	24.49	0.37	24.86	46.00	21.14	
	5.606	26.68	0.45	27.13	50.00	22.87	
	10.310	31.24	0.51	31.75	50.00	18.25	
Neutral	0.198	39.70	0.20	39.90	63.69	23.79	QP
	0.293	40.30	0.23	40.53	60.44	19.91	
	0.458	40.30	0.26	40.56	56.72	16.16	
	1.577	45.60	0.34	45.94	56.00	10.06	
	5.235	33.45	0.45	33.90	60.00	26.10	
	10.540	37.15	0.53	37.68	60.00	22.32	
	0.198	31.57	0.20	31.77	53.69	21.92	AV
	0.293	26.39	0.23	26.62	50.44	23.82	
	0.458	25.39	0.26	25.65	46.72	21.07	
	1.577	40.22	0.34	40.56	46.00	5.44	
	5.235	31.65	0.45	32.10	50.00	17.90	
	10.540	30.63	0.53	31.16	50.00	18.84	

TEST ENGINEER: HUGH HUANG

EUT : LCD TV Temperature : 22°C

Model No. : LTDN24V86US Humidity : 48%RH

Serial No. : E2009102101 Date of Test : Jan 04, 2010

Test Mode : D-Sub 800*600@60Hz

Test Line	Frequency (MHz)	Meter Reading dB(μ V)	Factor (dB)	Emission Level dB(μ V)	Limits dB(μ V)	Margin (dB)	Remark
Line	0.199	41.97	0.22	42.19	63.67	21.48	QP
	0.266	41.67	0.24	41.91	61.24	19.33	
	0.626	37.26	0.28	37.54	56.00	18.46	
	1.262	37.32	0.32	37.64	56.00	18.36	
	6.777	28.01	0.47	28.48	60.00	31.52	
	10.350	37.22	0.51	37.73	60.00	22.27	
	0.199	32.74	0.22	32.96	53.67	20.71	AV
	0.266	30.13	0.24	30.37	51.24	20.87	
	0.626	24.47	0.28	24.75	46.00	21.25	
	1.262	32.74	0.32	33.06	46.00	12.94	
	6.777	20.70	0.47	21.17	50.00	28.83	
	10.350	31.43	0.51	31.94	50.00	18.06	
Neutral	0.197	38.38	0.20	38.58	63.76	25.18	QP
	0.282	40.12	0.22	40.34	60.75	20.41	
	0.689	37.47	0.27	37.74	56.00	18.26	
	1.539	42.82	0.34	43.16	56.00	12.84	
	5.177	32.46	0.45	32.91	60.00	27.09	
	10.450	37.63	0.53	38.16	60.00	21.84	
	0.197	28.67	0.20	28.87	53.76	24.89	AV
	0.282	27.88	0.22	28.10	50.75	22.65	
	0.689	25.35	0.27	25.62	46.00	20.38	
	1.539	33.85	0.34	34.19	46.00	11.81	
	5.177	25.23	0.45	25.68	50.00	24.32	
	10.450	31.75	0.53	32.28	50.00	17.72	

TEST ENGINEER: HUGH HUANG

EUT : LCD TV Temperature : 22°C

Model No. : LTDN24V86US Humidity : 48%RH

Serial No. : E2009102101 Date of Test : Jan 04, 2010

Test Mode : D-Sub 1024*768@60Hz

Test Line	Frequency (MHz)	Meter Reading dB(μV)	Factor (dB)	Emission Level dB(μV)	Limits dB(μV)	Margin (dB)	Remark
Line	0.196	42.03	0.22	42.25	63.77	21.52	QP
	0.276	41.86	0.25	42.11	60.94	18.83	
	0.635	37.12	0.28	37.40	56.00	18.60	
	1.262	35.06	0.32	35.38	56.00	20.62	
	10.490	35.99	0.51	36.50	60.00	23.50	
	21.700	27.75	0.86	28.61	60.00	31.39	
	0.196	32.65	0.22	32.87	53.77	20.90	AV
	0.276	29.59	0.25	29.84	50.94	21.10	
	0.635	25.44	0.28	25.72	46.00	20.28	
	1.262	28.45	0.32	28.77	46.00	17.23	
	10.490	30.23	0.51	30.74	50.00	19.26	
	21.700	24.21	0.86	25.07	50.00	24.93	
Neutral	0.194	38.45	0.20	38.65	63.88	25.23	QP
	0.289	39.86	0.23	40.09	60.54	20.45	
	0.681	37.85	0.27	38.12	56.00	17.88	
	1.466	44.53	0.34	44.87	56.00	11.13	
	5.236	33.09	0.45	33.54	60.00	26.46	
	10.100	38.20	0.51	38.71	60.00	21.29	
	0.194	27.77	0.20	27.97	53.88	25.91	AV
	0.289	26.79	0.23	27.02	50.54	23.52	
	0.681	22.48	0.27	22.75	46.00	23.25	
	1.466	34.38	0.34	34.72	46.00	11.28	
	5.236	24.70	0.45	25.15	50.00	24.85	
	10.100	31.45	0.51	31.96	50.00	18.04	

TEST ENGINEER: HUGH HUANG

EUT : LCD TV Temperature : 22°C

Model No. : LTDN24V86US Humidity : 48%RH

Serial No. : E2009102101 Date of Test : Jan 04, 2010

Test Mode : HDMI 640*480@60Hz

Test Line	Frequency (MHz)	Meter Reading dB(μ V)	Factor (dB)	Emission Level dB(μ V)	Limits dB(μ V)	Margin (dB)	Remark
Line	0.199	41.83	0.22	42.05	63.64	21.59	QP
	0.261	41.90	0.24	42.14	61.42	19.28	
	0.631	38.23	0.28	38.51	56.00	17.49	
	1.262	38.46	0.32	38.78	56.00	17.22	
	5.162	30.67	0.44	31.11	60.00	28.89	
	10.250	37.85	0.51	38.36	60.00	21.64	
	0.199	32.69	0.22	32.91	53.64	20.73	AV
	0.261	30.55	0.24	30.79	51.42	20.63	
	0.631	29.24	0.28	29.52	46.00	16.48	
	1.262	34.93	0.32	35.25	46.00	10.75	
	5.162	22.92	0.44	23.36	50.00	26.64	
	10.250	31.66	0.51	32.17	50.00	17.83	
Neutral	0.198	38.38	0.20	38.58	63.69	25.11	QP
	0.286	40.05	0.22	40.27	60.64	20.37	
	0.513	39.08	0.26	39.34	56.00	16.66	
	1.467	44.32	0.34	44.66	56.00	11.34	
	5.206	31.99	0.45	32.44	60.00	27.56	
	10.210	38.41	0.51	38.92	60.00	21.08	
	0.198	28.75	0.20	28.95	53.69	24.74	AV
	0.286	27.74	0.22	27.96	50.64	22.68	
	0.513	27.77	0.26	28.03	46.00	17.97	
	1.467	34.53	0.34	34.87	46.00	11.13	
	5.206	24.72	0.45	25.17	50.00	24.83	
	10.210	32.82	0.51	33.33	50.00	16.67	

TEST ENGINEER: HUGH HUANG

EUT : LCD TV Temperature : 22°C

Model No. : LTDN24V86US Humidity : 48%RH

Serial No. : E2009102101 Date of Test : Jan 04, 2010

Test Mode : HDMI 800*600@60Hz

Test Line	Frequency (MHz)	Meter Reading dB(μ V)	Factor (dB)	Emission Level dB(μ V)	Limits dB(μ V)	Margin (dB)	Remark
Line	0.199	41.82	0.22	42.04	63.64	21.60	QP
	0.283	41.94	0.25	42.19	60.74	18.55	
	0.631	37.99	0.28	38.27	56.00	17.73	
	1.263	38.61	0.32	38.93	56.00	17.07	
	10.280	37.64	0.51	38.15	60.00	21.85	
	24.380	29.13	0.81	29.94	60.00	30.06	
	0.199	32.68	0.22	32.90	53.64	20.74	AV
	0.283	29.22	0.25	29.47	50.74	21.27	
	0.631	29.08	0.28	29.36	46.00	16.64	
	1.263	34.86	0.32	35.18	46.00	10.82	
	10.280	31.74	0.51	32.25	50.00	17.75	
	24.380	23.54	0.81	24.35	50.00	25.65	
Neutral	0.192	38.34	0.20	38.54	63.94	25.40	QP
	0.281	40.16	0.22	40.38	60.77	20.39	
	0.673	37.40	0.27	37.67	56.00	18.33	
	1.470	43.46	0.34	43.80	56.00	12.20	
	5.233	33.81	0.45	34.26	60.00	25.74	
	10.320	40.09	0.52	40.61	60.00	19.39	
	0.192	26.62	0.20	26.82	53.94	27.12	AV
	0.281	27.93	0.22	28.15	50.77	22.62	
	0.673	21.89	0.27	22.16	46.00	23.84	
	1.470	34.65	0.34	34.99	46.00	11.01	
	5.233	24.82	0.45	25.27	50.00	24.73	
	10.320	33.31	0.52	33.83	50.00	16.17	

TEST ENGINEER: HUGH HUANG

EUT : LCD TV Temperature : 22°C

Model No. : LTDN24V86US Humidity : 48%RH

Serial No. : E2009102101 Date of Test : Jan 04, 2010

Test Mode : HDMI 1024*768@60Hz

Test Line	Frequency (MHz)	Meter Reading dB(μ V)	Factor (dB)	Emission Level dB(μ V)	Limits dB(μ V)	Margin (dB)	Remark
Line	0.194	42.07	0.22	42.29	63.85	21.56	QP
	0.257	41.89	0.24	42.13	61.52	19.39	
	0.631	37.64	0.28	37.92	56.00	18.08	
	1.258	35.75	0.32	36.07	56.00	19.93	
	5.234	31.31	0.44	31.75	60.00	28.25	
	10.370	36.94	0.51	37.45	60.00	22.55	
	0.194	32.13	0.22	32.35	53.85	21.50	AV
	0.257	29.37	0.24	29.61	51.52	21.91	
	0.631	27.74	0.28	28.02	46.00	17.98	
	1.258	29.22	0.32	29.54	46.00	16.46	
	5.234	22.58	0.44	23.02	50.00	26.98	
	10.370	31.08	0.51	31.59	50.00	18.41	
Neutral	0.197	38.33	0.20	38.53	63.75	25.22	QP
	0.281	40.24	0.22	40.46	60.77	20.31	
	0.738	38.38	0.28	38.66	56.00	17.34	
	1.544	43.98	0.34	44.32	56.00	11.68	
	5.272	31.59	0.45	32.04	60.00	27.96	
	10.450	38.05	0.53	38.58	60.00	21.42	
	0.197	28.64	0.20	28.84	53.75	24.91	AV
	0.281	27.98	0.22	28.20	50.77	22.57	
	0.738	24.17	0.28	24.45	46.00	21.55	
	1.544	34.64	0.34	34.98	46.00	11.02	
	5.272	24.72	0.45	25.17	50.00	24.83	
	10.450	32.18	0.53	32.71	50.00	17.29	

TEST ENGINEER: HUGH HUANG

4 RADIATED EMISSION TEST

4.1 Test Equipment

The following test equipments are used during the radiated emission test in a semi-anechoic chamber:

Item	Type	Manufacturer	Model No.	Serial No.	Last Cal.	Next Cal.
1.	Test Receiver	R&S	ESVS10	844594/001	Mar 07, 2009	Mar 07, 2010
2.	Preamplifier	Agilent	8447D	2944A10548	Sep 19, 2009	Mar 19, 2010
3.	Bi-log Antenna	TESEQ	CBL6112D	23193	May 14, 2008	May 14, 2010
4.	Spectrum Analyzer	Agilent	E7405A	MY45106600	May 19, 2009	May 19, 2010
5.	Software	Audix	E3	SET00200 9912M295-2	--	--

4.2 Block Diagram of Test Setup

4.2.1 EUT and Peripherals

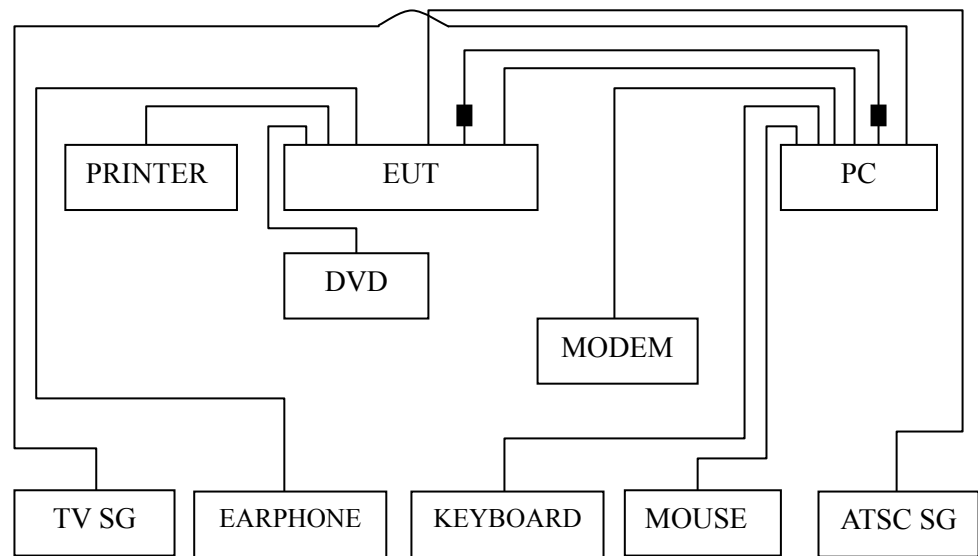

■ : Ferrite core

4.2.2 Radiated emission test setup

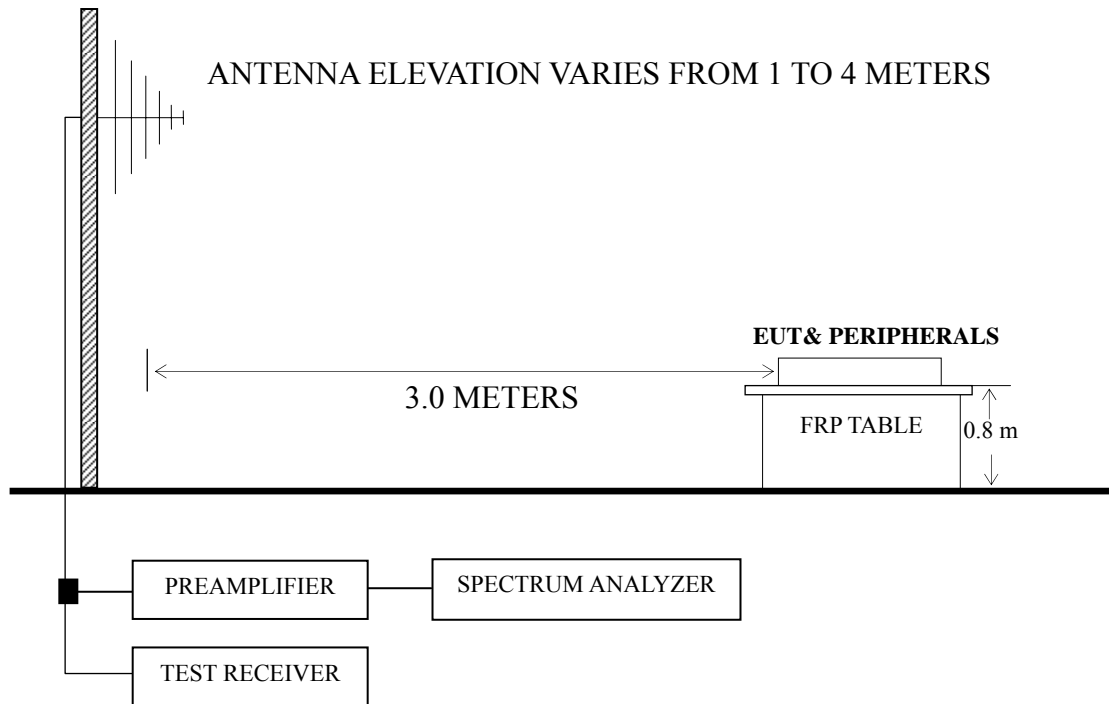

■ : 50 ohm Coaxial Switch

4.3 Radiated Emission Limit [FCC Part 15 Subpart B 15.109(a)]

Frequency (MHz)	Distance (m)	Field strength limits	
		($\mu\text{V/m}$)	dB ($\mu\text{V/m}$)
30 ~ 88	3	100	40.0
88 ~ 216	3	150	43.5
216 ~ 960	3	200	46.0
Above 960	3	500	54.0

NOTE 1 - Emission Level dB ($\mu\text{V/m}$) = 20 log Emission Level ($\mu\text{V/m}$)

NOTE 2 - The tighter limit applies at the band edges.

NOTE 3 - Distance refers to the distance in meters between the measuring instrument antenna and the closed point of any part of the device or system.

NOTE 4 - The limits shown are based on Quasi-peak value detector.

4.4 Test Configuration

The configuration of the EUT and peripherals are same as those used in conducted emission test.

Please refer to Sec.3.4.

4.5 Operating Condition of EUT

Same as conducted emission test which is listed in Sec.3.5, except for the test setup replaced by Sec.4.2.

4.6 Test Procedures

The EUT and peripherals were placed on a FRP turntable that is 0.8 meter above ground. The FRP turntable rotated 360 degrees to determine the position of the maximum emission level. The EUT was set 3 meters away from the receiving antenna, which was mounted on an antenna tower. Broadband antenna (Calibrated Bilog Antenna) was used as receiving antenna. The antenna moved up and down between 1 meter and 4 meters to find out the maximum emission level. Both horizontal and vertical polarizations of the antenna were set on measurement. In order to find the maximum emission, all of the interference cables were manipulated according to ANSI C63.4:2003 requirements during radiated emission test.

The bandwidth of Test Receiver R&S ESVS10 was set at 120 kHz.

The frequency range from 30 MHz to 1000MHz was checked for all test modes.

The test modes were done on radiated disturbance test and all the test results are listed in Sec.4.7.

4.7 Test Results

<PASS>

The frequency and amplitude of the highest radiated emission relative the limit is reported. All the emissions not reported below are too low against the FCC limit.

Test Mode	Data Page
D-Sub 640*480@60Hz	P22
D-Sub 800*600@60Hz	P23
D-Sub 1024*768@60Hz	P24
HDMI 640*480@60Hz	P25
HDMI 800*600@60Hz	P26
HDMI 1024*768@60Hz	P27

NOTE 1 – Emission Level = Antenna Factor + Cable Loss + Meter Reading.

NOTE 2 – The emission levels that are 20dB below the official limit are not reported.

NOTE 3 – 0° was the table front facing the antenna. Degree is calculated from 0° clockwise facing the antenna.

NOTE 4 – The worst case is for D-Sub 1024*768@60Hz test mode. The worst emission at horizontal polarization was detected at 664.380 MHz with corrected signal level of 42.49dB ($\mu\text{V}/\text{m}$) (limit is 46.00dB ($\mu\text{V}/\text{m}$)), when the antenna was 1.30 m height and the turntable was at 140°. The worst emission at vertical polarization was detected at 668.000 MHz with corrected signal level of 42.17 dB ($\mu\text{V}/\text{m}$) (limit is 46.00 dB ($\mu\text{V}/\text{m}$)), when the antenna was 1.00 m height and the turntable was at 250°.

EUT : LCD TV Temperature : 22°C

Model No. : LTDN24V86US Humidity : 60%RH

Serial No. : E2009102101 Date of Test : Jan 05, 2010

Test Mode : D-Sub 640*480@60Hz

Polarization	Frequency (MHz)	Meter Reading dB (μV)	Antenna Factor (dB/m)	Cable Loss (dB)	Emission Level dB (μV/m)	Limits dB (μV/m)	Margin (dB)
Horizontal	82.380	23.97	8.19	0.98	33.14	40.00	6.86
	101.780	19.60	11.63	1.05	32.28	43.50	11.22
	202.500	25.80	10.81	1.46	38.07	43.50	5.43
	271.530	17.26	13.37	1.67	32.30	46.00	13.70
	405.390	14.60	16.57	2.04	33.21	46.00	12.79
	667.290	15.93	19.55	2.62	38.10	46.00	7.90
Vertical	48.430	24.20	9.62	0.75	34.57	40.00	5.43
	77.530	23.12	7.49	0.93	31.54	40.00	8.46
	101.780	20.33	11.63	1.05	33.01	43.50	10.49
	203.630	23.37	10.85	1.47	35.69	43.50	7.81
	271.530	18.46	13.37	1.67	33.50	46.00	12.50
	363.680	22.32	15.69	1.94	39.95	46.00	6.05

TEST ENGINEER: RAVEN JIN

EUT : LCD TV Temperature : 22°C

Model No. : LTDN24V86US Humidity : 60%RH

Serial No. : E2009102101 Date of Test : Jan 05, 2010

Test Mode : D-Sub 800*600@60Hz

Polarization	Frequency (MHz)	Meter Reading dB (μ V)	Antenna Factor (dB/m)	Cable Loss (dB)	Emission Level dB (μ V/m)	Limits dB (μ V/m)	Margin (dB)
Horizontal	48.430	22.72	9.62	0.75	33.09	40.00	6.91
	101.780	20.68	11.63	1.05	33.36	43.50	10.14
	203.630	25.37	10.85	1.47	37.69	43.50	5.81
	368.530	23.07	15.81	1.96	40.84	46.00	5.16
	412.180	20.53	16.67	2.07	39.27	46.00	6.73
	662.440	19.44	19.52	2.62	41.58	46.00	4.42
Vertical	82.380	24.18	8.19	0.98	33.35	40.00	6.65
	202.500	27.00	10.81	1.46	39.27	43.50	4.23
	293.840	21.24	13.79	1.76	36.79	46.00	9.21
	405.390	14.54	16.57	2.04	33.15	46.00	12.85
	672.140	19.90	19.57	2.59	42.06	46.00	3.94
	809.880	12.45	20.80	2.87	36.12	46.00	9.88

TEST ENGINEER: RAVEN JIN

EUT : LCD TV Temperature : 22°C

Model No. : LTDN24V86US Humidity : 60%RH

Serial No. : E2009102101 Date of Test : Jan 05, 2010

Test Mode : D-Sub 1024*768@60Hz

Polarization	Frequency (MHz)	Meter Reading dB (μV)	Antenna Factor (dB/m)	Cable Loss (dB)	Emission Level dB (μV/m)	Limits dB (μV/m)	Margin (dB)
Horizontal	82.380	23.78	8.19	0.98	32.95	40.00	7.05
	145.430	23.86	11.66	1.22	36.74	43.50	6.76
	182.290	27.03	9.99	1.38	38.40	43.50	5.10
	202.500	26.00	10.81	1.46	38.27	43.50	5.23
	288.990	21.35	13.71	1.71	36.77	46.00	9.23
	664.380	20.33	19.54	2.62	42.49	46.00	3.51
Vertical	48.430	24.27	9.62	0.75	34.64	40.00	5.36
	101.780	20.98	11.63	1.05	33.66	43.50	9.84
	368.530	23.25	15.81	1.96	41.02	46.00	4.98
	412.180	21.87	16.67	2.07	40.61	46.00	5.39
	668.000	20.00	19.55	2.62	42.17	46.00	3.83
	732.280	16.15	20.04	2.75	38.94	46.00	7.06

TEST ENGINEER: RAVEN JIN

EUT : LCD TV Temperature : 22°C

Model No. : LTDN24V86US Humidity : 60%RH

Serial No. : E2009102101 Date of Test : Jan 05, 2010

Test Mode : HDMI 640*480@60Hz

Polarization	Frequency (MHz)	Meter Reading dB (μV)	Antenna Factor (dB/m)	Cable Loss (dB)	Emission Level dB (μV/m)	Limits dB (μV/m)	Margin (dB)
Horizontal	82.380	21.97	8.19	0.98	31.14	40.00	8.86
	101.780	17.60	11.63	1.05	30.28	43.50	13.22
	153.190	12.89	11.04	1.24	25.17	43.50	18.33
	203.630	23.57	10.85	1.47	35.89	43.50	7.61
	303.540	14.22	14.00	1.75	29.97	46.00	16.03
	405.390	12.60	16.57	2.04	31.21	46.00	14.79
Vertical	48.430	21.20	9.62	0.75	31.57	40.00	8.43
	77.530	20.12	7.49	0.93	28.54	40.00	11.46
	101.780	16.33	11.63	1.05	29.01	43.50	14.49
	203.630	20.37	10.85	1.47	32.69	43.50	10.81
	363.680	20.32	15.69	1.94	37.95	46.00	8.05
	652.740	16.00	19.47	2.61	38.08	46.00	7.92

TEST ENGINEER: RAVEN JIN

EUT : LCD TV Temperature : 22°C

Model No. : LTDN24V86US Humidity : 60%RH

Serial No. : E2009102101 Date of Test : Jan 05, 2010

Test Mode : HDMI 800*600@60Hz

Polarization	Frequency (MHz)	Meter Reading dB (μV)	Antenna Factor (dB/m)	Cable Loss (dB)	Emission Level dB (μV/m)	Limits dB (μV/m)	Margin (dB)
Horizontal	48.430	19.72	9.62	0.75	30.09	40.00	9.91
	101.780	18.68	11.63	1.05	31.36	43.50	12.14
	203.630	23.37	10.85	1.47	35.69	43.50	7.81
	368.530	21.07	15.81	1.96	38.84	46.00	7.16
	412.180	18.53	16.67	2.07	37.27	46.00	8.73
	662.440	17.44	19.52	2.62	39.58	46.00	6.42
Vertical	82.380	21.18	8.19	0.98	30.35	40.00	9.65
	101.780	16.18	11.63	1.05	28.86	43.50	14.64
	203.630	24.00	10.85	1.47	36.32	43.50	7.18
	293.840	16.24	13.79	1.76	31.79	46.00	14.21
	405.390	9.54	16.57	2.04	28.15	46.00	17.85
	672.140	14.90	19.57	2.59	37.06	46.00	8.94

TEST ENGINEER: RAVEN JIN

EUT : LCD TV Temperature : 22°C

Model No. : LTDN24V86US Humidity : 60%RH

Serial No. : E2009102101 Date of Test : Jan 05, 2010

Test Mode : HDMI 1024*768@60Hz

Polarization	Frequency (MHz)	Meter Reading dB (μ V)	Antenna Factor (dB/m)	Cable Loss (dB)	Emission Level dB (μ V/m)	Limits dB (μ V/m)	Margin (dB)
Horizontal	82.380	21.78	8.19	0.98	30.95	40.00	9.05
	145.430	20.86	11.66	1.22	33.74	43.50	9.76
	203.630	24.41	10.85	1.47	36.73	43.50	6.77
	288.990	17.35	13.71	1.71	32.77	46.00	13.23
	366.590	14.65	15.77	1.96	32.38	46.00	13.62
	664.380	18.33	19.54	2.62	40.49	46.00	5.51
Vertical	48.430	20.27	9.62	0.75	30.64	40.00	9.36
	101.780	15.98	11.63	1.05	28.66	43.50	14.84
	288.990	15.82	13.71	1.71	31.24	46.00	14.76
	368.530	18.25	15.81	1.96	36.02	46.00	9.98
	412.180	16.87	16.67	2.07	35.61	46.00	10.39
	669.230	17.04	19.55	2.62	39.21	46.00	6.79

TEST ENGINEER: RAVEN JIN

5 DEVIATION TO TEST SPECIFICATIONS

None.

6 DEBUG DESCRIPTION

The following components are used during the countermeasure procedures:

Name	M/N	Specification (mm)	Manufacturer	Location
Ferrite core	ZCAT3035-1330\ROH	--	Bilusi	See Internal Photo Figure 18-1
Aluminum foil	DBA40X100\ROH	--	Zhuoying	See Internal Photo Figure 18-2

Note: We had required the applicant and manufacturer that all electrical and mechanical devices employed for spurious radiation suppression, including any modifications made during certification testing, must be incorporated in each unit marked

TEST ENGINEER: Raven Jin
(RAVEN JIN)