

Application for FCC Certificate
On Behalf of
Hisense Electric Co., Ltd.

LCD TV

Model No.	Serial No.	Brand
LCD19W57ACA	E2010062501	Hisense
LHD19V68US	--	
ELCHS192	--	Element

FCC ID : W9HLCDA0001

Prepared For : Hisense Electric Co., Ltd.
No.218 Qianwangang Road, Economy & Technology
Development Zone, Qingdao, China

Prepared By : Audix Technology (Shanghai) Co., Ltd.
3F 34Bldg 680 Guiping Rd,
Caohejing Hi-Tech Park,
Shanghai 200233, China

Tel: +86-21-64955500

Fax: +86-21-64955491

Report No. : ACI-F09066A2
Date of Test : Jun 28, 2010
Date of Report : Jul 06, 2010

TABLE OF CONTENTS

	Page
1 SUMMARY OF STANDARDS AND RESULTS	4
1.1 Description of Standards and Results.....	4
2 GENERAL INFORMATION	5
2.1 Description of Equipment Under Test.....	5
2.2 Peripherals.....	7
2.3 Description of Test Facility.....	8
2.4 Measurement Uncertainty.....	8
3 CONDUCTED EMISSION TEST	9
3.2 Block Diagram of Test Setup.....	9
3.3 Conducted Emission Limit [FCC Part 15 Subpart B 15.107(a)].....	10
3.4 Test Configuration.....	10
3.5 Operating Condition of EUT.....	11
3.6 Test Procedures.....	11
3.7 Test Results.....	12
4 RADIATED EMISSION TEST	19
4.1 Test Equipment.....	19
4.2 Block Diagram of Test Setup.....	19
4.3 Radiated Emission Limit [FCC Part 15 Subpart B 15.109(a)].....	20
4.4 Test Configuration.....	20
4.5 Operating Condition of EUT.....	20
4.6 Test Procedures.....	21
4.7 Test Results.....	21
5 DEVIATION TO TEST SPECIFICATIONS	28
6 DEBUG DESCRIPTION	29

TEST REPORT FOR FCC CERTIFICATE

Applicant : Hisense Electric Co., Ltd.
 Manufacturer : Hisense Electric Co., Ltd.
 EUT Description : LCD TV

Model No.	Serial No.	Brand	Power Supply
LCD19W57ACA	E2010062501	Hisense	120V/60Hz
LHD19V68US	--		
ELCHS192	--	Element	

Test Procedure Used:

*FCC RULES AND REGULATIONS PART 15 SUBPART B CLASS B OCTOBER 2010
AND ANSI C63.4-2003*

The device described above is tested by Audix Technology (Shanghai) Co., Ltd. to determine the maximum emission levels emanating from the device. The maximum emission levels are compared to the FCC Part 15 Subpart B (Class B) limits both radiated and conducted emissions.

The test results are contained in this test report and Audix Technology (Shanghai) Co., Ltd. is assumed full responsibility for the accuracy and completeness of these measurements. This report shows that the EUT (M/N: Refer to Sec.2.1; S/N: Refer to Sec.2.1) which was tested in 3m anechoic chamber Jun 28, 2010 is technically compliance with the FCC official limits also.

This report applies to above tested sample only. This report shall not be reproduced in part without written approval of Audix Technology (Shanghai) Co., Ltd.

This report contains data that are not covered by the NVLAP accreditation.

This report must not be used by the client to claim product certification, approval, or endorsement by NVLAP, NIST, or any agency of the federal government.

The test results for EUT's TV functions are contained in No.F09065A2, a Verification report.

Date of Test : Jun 28, 2010 Date of Report : Jul 06, 2010

Producer : 
KATHY WANG / Assistant

Review : 
DIO YANG / Deputy Assistant Manager

AUDIX[®] For and on behalf of
Audix Technology (Shanghai) Co., Ltd.

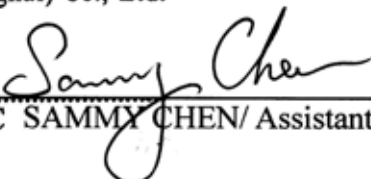
Signatory : 
Authorized Signature EMC SAMMY CHEN / Assistant Manager

1 SUMMARY OF STANDARDS AND RESULTS

1.1 Description of Standards and Results

The EUT have been tested according to the applicable standards as referenced below:

Description of Test Item	Standard	Limits	Results
EMISSION			
Conducted Disturbance at the Mains Terminal	FCC RULES AND REGULATIONS PART 15 SUBPART B OCTOBER 2010 AND ANSI C63.4-2003	15.107(a) Class B	Pass
Radiated Disturbance	FCC RULES AND REGULATIONS PART 15 SUBPART B OCTOBER 2010 AND ANSI C63.4-2003	15.109(a) Class B	Pass

2 GENERAL INFORMATION

2.1 Description of Equipment Under Test

Description : LCD TV

Type of EUT : Production Pre-product Pro-type

Model No.	Serial No.	Brand
LCD19W57ACA	E2010062501	Hisense
LHD19V68US	--	
ELCHS192	--	Element

Note 1 : The difference list for all models are as follows:

Report No.	Model No.	Rev. Summary	Edition No.	Data of Rev.
ACI-F09066	LCD19W57ACA, LCDN19V68CA, LHD19V68US, ELCHS192	Original Report.	0	Jul 24, 2009
ACI-F09066A1	LCD19W57ACA, LHD19V68US, ELCHS192	To change LCD panel, main board and power.	Rev. A1	Oct 29, 2009
ACI-F09066A2	LCD19W57ACA, LHD19V68US, ELCHS192	To change LCD panel and main chip	Rev. A2	Jul 06, 2010

Note 2 : The above models are all the same except for the different model number and brand.

Note 3 : The LCD19W57ACA was tested and recorded in this report.

Applicant : Hisense Electric Co., Ltd.
No.218 Qianwangang Road, Economy & Technology Development Zone, Qingdao, China

Manufacturer : Hisense Electric Co., Ltd.
No.218 Qianwangang Road, Economy & Technology Development Zone, Qingdao, China

LCD Panel : Manufacturer : LG Display
M/N : LC185WH1(TL)(G1)

Max Resolution : 1360*768@60Hz

D-Sub Cable	:	Shielded, Detachable, 1.85m, with two cores on cable
HDMI Cable	:	Shielded, Detachable, 1.85m, without core on cable
Power Cord	:	Unshielded, Detachable, 1.80m

Remark:

The EUT is a LCD TV which input/output ports as follows:

Rear View:

- | | | |
|-----|-----------------------------------|------------------------------|
| (1) | One component of YPbPr Port | Connected with DVD |
| (2) | One component of YPbPr Audio Port | Connected with DVD |
| (3) | One HDMI Port | Connected with DVD |
| (4) | One VGA Port | Connected with PC |
| (5) | One component of AV Out Port | Connected with TV |
| (6) | One component of AV In1 Port | Connected with DVD |
| (7) | One S-Video Port | Connected with TV SG |
| (8) | One ANT Port | Connected with TV SG/ATSC SG |
| (9) | One Headphone Port | Connected with Earphone |

Side Port:

- | | | |
|------|------------------------------|-------------------------------------|
| (10) | One component of AV In2 Port | Connected with TV SG |
| (11) | One USB (Service) Port | Connected with U-Disk as Terminator |

2.2 Peripherals

2.2.1 PC

Manufacturer : HP
Model Number : dx7200MT
Serial Number : CNG622017W
Power Cord : Unshielded, Detachable, 1.8m
Certificate : FCC DoC; CE/EMC; VCCI; C-Tick; UL
BSMI (R33001) 3C (A000111)
MIC (E-A011-04-2659(B))

2.2.2 Printer

Manufacturer : HP
Model Number : C3990A
Serial Number : JPZX020487
Data Cable : Shielded, detachable, 1.5m
Certificate : GS, CE/EMC, C-Tick, FCC DoC

2.2.3 Keyboard

Manufacturer : Microsoft
Model Number : RT2300
Serial Number : 7668200662248
Data Cable : Shielded, undetachable ,1.8m
Certificate : CE/EMC, FCC DoC, VCCI, MIC, C-Tick,
BSMI

2.2.4 Mouse

Manufacturer : Microsoft
Model Number : RT2300
Serial Number : 6965712071551
Data Cable : Shielded, undetachable, 1.8m.
Certificate : CE/EMC, FCC DoC, VCCI, MIC, C-Tick,
BSMI

2.2.5 Modem

Manufacturer : TP-LINK
Model Number : TM-EC5658V
Serial Number : 07123301053
Data Cable : Shielded, Detachable, 1.8m
Certificate : FCC DoC, CE/EMC, CCC

2.2.6 Earphone

Manufacturer : SONY
Model Number : MDR-E808
Serial Number : 1808030805305506

2.2.7 TV Signal Generator

Manufacturer : FLUKE
Model Number : 54200m01
Serial Number : 814008
Data Cable : Shielded, detachable, 2.0m
Power Cord : Unshielded, detachable, 2.0m
Certificate : CE/EMC, FCC DoC, CCC

2.2.8 ATSC Signal Generator

Manufacturer : SENCORE
Model Number : ATSC997
Serial Number : 6790071

2.2.9 DVD

Manufacturer : PHILIPS
Model Number : DVP3986K/93
Serial Number : KX1A0902120108
Certificate : FCC DoC, CE/EMC, CCC

2.2.10 TV

Manufacturer : SOYEA
Model Number : V1453 (M)
Data Cable : Unshielded, undetachable, 1.5m
Certificate : FCC DoC, CE/EMC, CCC

2.3 Description of Test Facility

Site Description (Semi-Anechoic Chamber) : Sept. 17, 1998 file on
Apr 29, 2009 Renewed
Federal Communications Commission
FCC Engineering Laboratory
7435 Oakland Mills Road
Columbia, MD 21046, USA

Name of Firm : Audix Technology (Shanghai) Co., Ltd.

Site Location : 3F 34Bldg 680 Guiping Rd,
Caohejing Hi-Tech Park,
Shanghai 200233, China

NVLAP Lab Code : 200371-0

2.4 Measurement Uncertainty

Conducted Emission Expanded Uncertainty: U = 1.26 dB
Radiated Emission Expanded Uncertainty : U = 3.02 dB

3 CONDUCTED EMISSION TEST

3.1.1 Test Equipment

The following test equipments are used during the conducted emission test in a shielded room:

Item	Type	Manufacturer	Model No.	Serial No.	Last Cal.	Next Cal.
1.	Test Receiver	R&S	ESCI	100841	Nov 21, 2009	Nov 21, 2010
2.	Artificial Mains Network (AMN)	R&S	ESH2-Z5	843890/011	Apr 02, 2010	Apr 02, 2011
3.	Line Impedance Stabilization Network (LISN)	Kyoritsu	KNW-407	8-1280-4	Apr 02, 2010	Apr 02, 2011
4.	50 Ω Coaxial Switch	Anritsu	MP59B	6200426389	Mar 19, 2010	Sep 19, 2010
5.	50 Ω Terminator	Anritsu	BNC	001	Apr 02, 2010	Apr 02, 2011
6.	Software	Audix	E3	SET00200 9804M592	--	--

3.2 Block Diagram of Test Setup

3.2.1 EUT & Peripherals

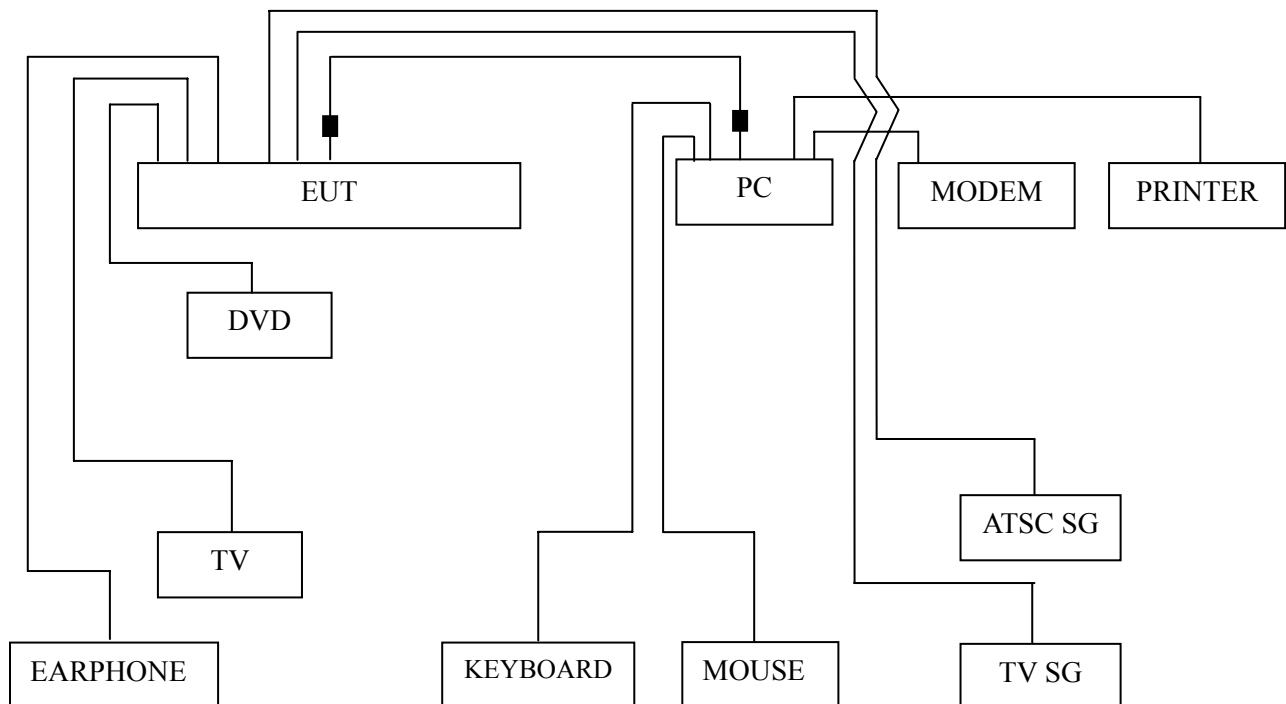

■ : Ferrite core

3.2.2 Conducted Disturbance Test Setup

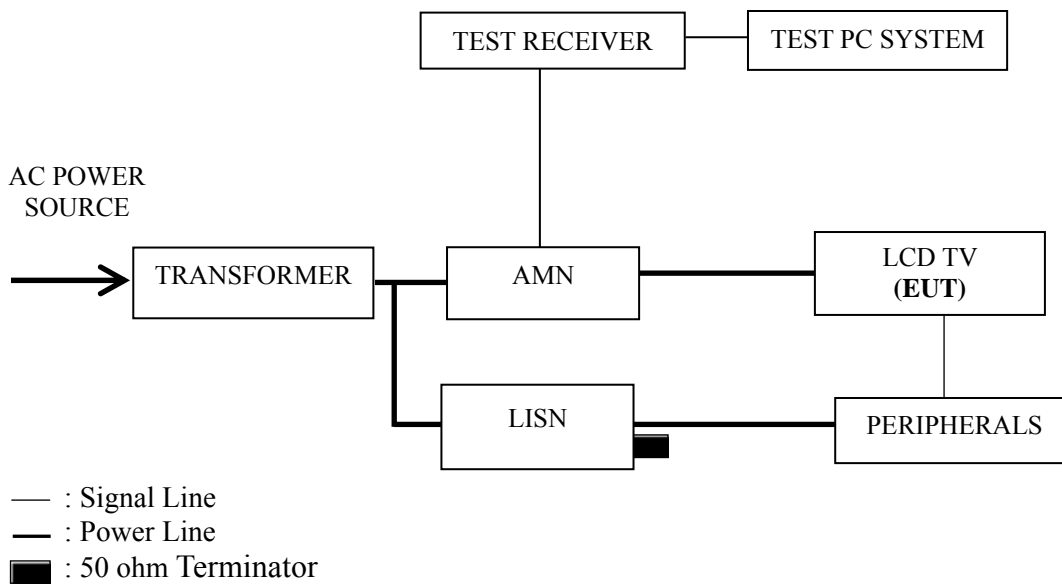

3.3 Conducted Emission Limit [FCC Part 15 Subpart B 15.107(a)]

Frequency Range (MHz)	Limits dB (μ V)	
	Quasi-peak	Average
0.15 ~ 0.5	66~56	56~46
0.5 ~ 5	56	46
5 ~ 30	60	50

NOTE 1 – The lower limit shall apply at the transition frequencies.
 NOTE 2 – The limit decreases linearly with the logarithm of the frequency in the range 0.15 MHz~0.50 MHz

3.4 Test Configuration

The EUT (listed in Sec.2.1) and the peripherals (listed in Sec 2.2) were installed as shown on Sec.3.2 to meet FCC requirement and operating in a manner that tends to maximize its emission level in a normal application.

3.5 Operating Condition of EUT

3.5.1 Setup the EUT and peripherals as shown in Sec. 3.2.

3.5.2 Turn on the power of all equipments and the EUT.

3.5.3 Set the contrast & brightness of EUT to maximum.

3.5.4 PC system ran the self-test program “EMC Test” by windows XP and sent “H” characters to EUT through graphic card, the EUT’s screen displayed and filled with “H” pattern by its resolution (Via D-Sub & HDMI Input).

3.5.5 Repeat above procedure from 3.5.3 to 3.5.4 for difference test mode.

3.5.6 The other peripherals devices were driven and operated during the test.

3.5.7 The test modes are as follows:

Test Mode
D-Sub 640*480@60Hz
D-Sub 1024*768@60Hz
D-Sub 1360*768@60Hz
HDMI 640*480@60Hz
HDMI 1024*768@60Hz
HDMI 1360*768@60Hz

3.6 Test Procedures

The EUT and peripherals were connected to the power mains through an Artificial Mains Network (AMN). This provided a 50 ohm coupling impedance for the measuring equipment.

Both sides of AC line (Line & Neutral) were checked for maximum conducted interference. In order to find the maximum emission, the relative positions of equipment and all of the interface cables were changed or manipulated according to ANSI C63.4:2003 during conducted emission test.

The bandwidth of R&S Test Receiver ESCI was set at 9 kHz.

The frequency range from 150 kHz to 30 MHz was checked.

The test modes were done on conducted disturbance test and all the test results are listed in Sec. 3.7.

3.7 Test Results

< **PASS** >

The frequency and amplitude of the highest conducted emission relative to the limit is reported. All emissions not reported below are too low against the prescribed limits.

Test Mode	Data Page
D-Sub 640*480@60Hz	P13
D-Sub 1024*768@60Hz	P14
D-Sub 1360*768@60Hz	P15
HDMI 640*480@60Hz	P16
HDMI 1024*768@60Hz	P17
HDMI 1360*768@60Hz	P18

NOTE 1 – Factor = Cable Loss + AMN Factor.

NOTE 2 – Emission Level = Meter Reading + Factor.

NOTE 3 – “QP” means “Quasi-Peak” values, “AV” means “Average” values.

NOTE 4 – The worst case is for D-Sub 1024*768@60Hz test mode. The worst emission is detected at 28.003 MHz (Average Value) with corrected signal level of 24.75 dB (μV) (limit is 50.00 dB (μV)), when the Line of the EUT is connected to AMN.

EUT : LCD TV Temperature : 22°C

Model No. : LCD19W57ACA Humidity : 48%RH

Serial No. : E2010062501 Date of Test : Jun 28, 2010

Test Mode : D-Sub 640*480@60Hz

Test Line	Frequency (MHz)	Meter Reading dB(μ V)	Factor (dB)	Emission Level dB(μ V)	Limits dB(μ V)	Margin (dB)	Remark	
Line	0.188	30.94	0.39	31.33	64.11	32.78	QP	
	0.346	26.39	0.46	26.85	59.05	32.20		
	0.510	28.19	0.52	28.71	56.00	27.29		
	3.293	21.87	0.71	22.58	56.00	33.42		
	7.175	17.57	0.90	18.47	60.00	41.53		
	26.139	26.21	1.83	28.04	60.00	31.96		
	Line	0.188	15.76	0.39	16.15	54.11	37.96	AV
		0.346	13.76	0.46	14.22	49.05	34.83	
		0.510	18.10	0.52	18.62	46.00	27.38	
		3.293	14.36	0.71	15.07	46.00	30.93	
		7.175	10.82	0.90	11.72	50.00	38.28	
		26.139	20.16	1.83	21.99	50.00	28.01	
Neutral	0.160	29.63	0.32	29.95	65.47	35.52	QP	
	0.322	23.89	0.40	24.29	59.66	35.37		
	0.499	23.28	0.49	23.77	56.01	32.24		
	3.207	18.02	0.66	18.68	56.00	37.32		
	9.966	21.92	1.02	22.94	60.00	37.06		
	11.021	25.41	1.12	26.53	60.00	33.47		
	Neutral	0.160	6.61	0.32	6.93	55.47	48.54	AV
		0.322	8.69	0.40	9.09	49.66	40.57	
		0.499	8.54	0.49	9.03	46.01	36.98	
		3.207	8.85	0.66	9.51	46.00	36.49	
		9.966	14.06	1.02	15.08	50.00	34.92	
		11.021	17.55	1.12	18.67	50.00	31.33	

TEST ENGINEER: TED ZHU

EUT : LCD TV Temperature : 22°C

Model No. : LCD19W57ACA Humidity : 48%RH

Serial No. : E2010062501 Date of Test : Jun 28, 2010

Test Mode : D-Sub 1024*768@60Hz

Test Line	Frequency (MHz)	Meter Reading dB(μ V)	Factor (dB)	Emission Level dB(μ V)	Limits dB(μ V)	Margin (dB)	Remark
Line	0.160	31.27	0.38	31.65	65.47	33.82	QP
	0.346	28.11	0.46	28.57	59.05	30.48	
	0.510	27.75	0.52	28.27	56.00	27.73	
	3.293	21.42	0.71	22.13	56.00	33.87	
	5.535	22.94	0.83	23.77	60.00	36.23	
	28.003	27.59	1.86	29.45	60.00	30.55	
	0.160	6.88	0.38	7.26	55.47	48.21	AV
	0.346	13.01	0.46	13.47	49.05	35.58	
	0.510	17.12	0.52	17.64	46.00	28.36	
	3.293	13.96	0.71	14.67	46.00	31.33	
	5.535	13.87	0.83	14.70	50.00	35.30	
	28.003	22.89	1.86	24.75	50.00	25.25	
Neutral	0.197	32.80	0.30	33.10	63.76	30.66	QP
	0.332	24.94	0.40	25.34	59.40	34.06	
	0.510	24.07	0.49	24.56	56.00	31.44	
	4.721	20.05	0.73	20.78	56.00	35.22	
	7.175	25.71	0.87	26.58	60.00	33.42	
	10.790	28.77	1.10	29.87	60.00	30.13	
	0.197	21.44	0.30	21.74	53.76	32.02	AV
	0.332	9.22	0.40	9.62	49.40	39.78	
	0.510	15.46	0.49	15.95	46.00	30.05	
	4.721	10.69	0.73	11.42	46.00	34.58	
	7.175	10.86	0.87	11.73	50.00	38.27	
	10.790	17.41	1.10	18.51	50.00	31.49	

TEST ENGINEER: TED ZHU

EUT : LCD TV Temperature : 22°C

Model No. : LCD19W57ACA Humidity : 48%RH

Serial No. : E2010062501 Date of Test : Jun 28, 2010

Test Mode : D-Sub 1360*768@60Hz

Test Line	Frequency (MHz)	Meter Reading dB(μ V)	Factor (dB)	Emission Level dB(μ V)	Limits dB(μ V)	Margin (dB)	Remark
Line	0.161	29.07	0.38	29.45	65.43	35.98	QP
	0.322	23.88	0.45	24.33	59.66	35.33	
	0.510	24.66	0.52	25.18	56.00	30.82	
	4.721	19.13	0.79	19.92	56.00	36.08	
	9.966	21.74	1.06	22.80	60.00	37.20	
	10.564	27.60	1.09	28.69	60.00	31.31	
	0.161	6.42	0.38	6.80	55.43	48.63	AV
	0.322	8.95	0.45	9.40	49.66	40.26	
	0.510	15.62	0.52	16.14	46.00	29.86	
	4.721	10.20	0.79	10.99	46.00	35.01	
	9.966	13.93	1.06	14.99	50.00	35.01	
	10.564	19.21	1.09	20.30	50.00	29.70	
Neutral	0.160	29.34	0.32	29.66	65.47	35.81	QP
	0.343	24.57	0.41	24.98	59.13	34.15	
	0.510	24.53	0.49	25.02	56.00	30.98	
	3.399	18.54	0.67	19.21	56.00	36.79	
	9.966	21.81	1.02	22.83	60.00	37.17	
	25.321	26.20	1.87	28.07	60.00	31.93	
	0.160	6.15	0.32	6.47	55.47	49.00	AV
	0.343	16.58	0.41	16.99	49.13	32.14	
	0.510	15.64	0.49	16.13	46.00	29.87	
	3.399	10.74	0.67	11.41	46.00	34.59	
	9.966	13.88	1.02	14.90	50.00	35.10	
	25.321	20.49	1.87	22.36	50.00	27.64	

TEST ENGINEER: TED ZHU

EUT : LCD TV Temperature : 22°C

Model No. : LCD19W57ACA Humidity : 48%RH

Serial No. : E2010062501 Date of Test : Jun 28, 2010

Test Mode : HDMI 640*480@60Hz

Test Line	Frequency (MHz)	Meter Reading dB(μ V)	Factor (dB)	Emission Level dB(μ V)	Limits dB(μ V)	Margin (dB)	Remark
Line	0.199	33.59	0.38	33.97	63.67	29.70	QP
	0.363	25.22	0.47	25.69	58.65	32.96	
	0.510	26.63	0.52	27.15	56.00	28.85	
	3.207	20.56	0.71	21.27	56.00	34.73	
	7.175	15.62	0.90	16.52	60.00	43.48	
	17.849	16.69	1.47	18.16	60.00	41.84	
	0.199	21.33	0.38	21.71	53.67	31.96	AV
	0.363	8.35	0.47	8.82	48.65	39.83	
	0.510	16.23	0.52	16.75	46.00	29.25	
	3.207	13.83	0.71	14.54	46.00	31.46	
	7.175	9.42	0.90	10.32	50.00	39.68	
	17.849	11.86	1.47	13.33	50.00	36.67	
Neutral	0.195	35.00	0.30	35.30	63.82	28.52	QP
	0.385	24.60	0.43	25.03	58.17	33.14	
	0.505	22.49	0.49	22.98	56.00	33.02	
	4.672	20.95	0.72	21.67	56.00	34.33	
	8.637	21.34	0.95	22.29	60.00	37.71	
	11.021	29.25	1.12	30.37	60.00	29.63	
	0.194	21.63	0.31	21.94	53.84	31.90	AV
	0.385	10.03	0.43	10.46	48.17	37.71	
	0.505	9.31	0.49	9.80	46.00	36.20	
	4.672	13.12	0.72	13.84	46.00	32.16	
	8.637	14.50	0.95	15.45	50.00	34.55	
	11.021	20.78	1.12	21.90	50.00	28.10	

TEST ENGINEER: TED ZHU

EUT : LCD TV Temperature : 22°C

Model No. : LCD19W57ACA Humidity : 48%RH

Serial No. : E2010062501 Date of Test : Jun 28, 2010

Test Mode : HDMI 1024*768@60Hz

Test Line	Frequency (MHz)	Meter Reading dB(μV)	Factor (dB)	Emission Level dB(μV)	Limits dB(μV)	Margin (dB)	Remark
Line	0.188	31.57	0.39	31.96	64.11	32.15	QP
	0.317	26.26	0.45	26.71	59.80	33.09	
	0.499	26.72	0.52	27.24	56.01	28.77	
	3.074	20.70	0.70	21.40	56.00	34.60	
	7.175	22.90	0.90	23.80	60.00	36.20	
	28.003	27.57	1.86	29.43	60.00	30.57	
	0.188	15.10	0.39	15.49	54.11	38.62	AV
	0.317	11.36	0.45	11.81	49.80	37.99	
	0.499	11.23	0.52	11.75	46.01	34.26	
	3.074	12.79	0.70	13.49	46.00	32.51	
	7.175	12.02	0.90	12.92	50.00	37.08	
	28.003	20.96	1.86	22.82	50.00	27.18	
Neutral	0.160	29.56	0.32	29.88	65.47	35.59	QP
	0.367	20.77	0.43	21.20	58.56	37.36	
	0.516	23.59	0.49	24.08	56.00	31.92	
	3.293	16.95	0.66	17.61	56.00	38.39	
	9.966	21.21	1.02	22.23	60.00	37.77	
	28.603	26.93	1.91	28.84	60.00	31.16	
	0.160	5.19	0.32	5.51	55.47	49.96	AV
	0.367	1.37	0.43	1.80	48.56	46.76	
	0.516	17.26	0.49	17.75	46.00	28.25	
	3.293	8.87	0.66	9.53	46.00	36.47	
	9.966	13.09	1.02	14.11	50.00	35.89	
	28.603	21.53	1.91	23.44	50.00	26.56	

TEST ENGINEER: TED ZHU

EUT : LCD TV Temperature : 22°C

Model No. : LCD19W57ACA Humidity : 48%RH

Serial No. : E2010062501 Date of Test : Jun 28, 2010

Test Mode : HDMI 1360*768@60Hz

Test Line	Frequency (MHz)	Meter Reading dB(μV)	Factor (dB)	Emission Level dB(μV)	Limits dB(μV)	Margin (dB)	Remark
Line	0.161	28.77	0.38	29.15	65.43	36.28	QP
	0.352	25.35	0.46	25.81	58.91	33.10	
	0.510	27.13	0.52	27.65	56.00	28.35	
	3.207	20.27	0.71	20.98	56.00	35.02	
	7.175	17.45	0.90	18.35	60.00	41.65	
	28.603	27.45	1.87	29.32	60.00	30.68	
	0.161	5.37	0.38	5.75	55.43	49.68	AV
	0.352	11.41	0.46	11.87	48.91	37.04	
	0.510	16.40	0.52	16.92	46.00	29.08	
	3.207	12.54	0.71	13.25	46.00	32.75	
	7.175	10.86	0.90	11.76	50.00	38.24	
	28.603	21.81	1.87	23.68	50.00	26.32	
Neutral	0.161	28.63	0.32	28.95	65.43	36.48	QP
	0.440	23.28	0.46	23.74	57.07	33.33	
	0.510	23.15	0.49	23.64	56.00	32.36	
	4.454	19.03	0.72	19.75	56.00	36.25	
	8.637	20.38	0.95	21.33	60.00	38.67	
	11.080	27.83	1.13	28.96	60.00	31.04	
	0.161	4.99	0.32	5.31	55.43	50.12	AV
	0.440	17.65	0.46	18.11	47.07	28.96	
	0.510	13.36	0.49	13.85	46.00	32.15	
	4.454	9.53	0.72	10.25	46.00	35.75	
	8.637	12.78	0.95	13.73	50.00	36.27	
	11.080	19.70	1.13	20.83	50.00	29.17	

TEST ENGINEER: TED ZHU

4 RADIATED EMISSION TEST

4.1 Test Equipment

The following test equipments are used during the radiated emission test in a semi-anechoic chamber:

Item	Type	Manufacturer	Model No.	Serial No.	Last Cal.	Next Cal.
1.	Test Receiver	R&S	ESVS10	844594/001	Mar 07, 2010	Mar 07, 2011
2.	Preamplifier	Agilent	8447D	2944A10548	Mar 19, 2010	Sep 19, 2010
3.	Bi-log Antenna	TESEQ	CBL6112D	23192	Dec 01, 2009	Dec 01, 2010
4.	Spectrum	Agilent	E7405A	MY45106600	May 19, 2010	May 19, 2011
5.	Software	Audix	E3	SET00200 9912M295-2	--	--

4.2 Block Diagram of Test Setup

4.2.1 EUT and Peripherals

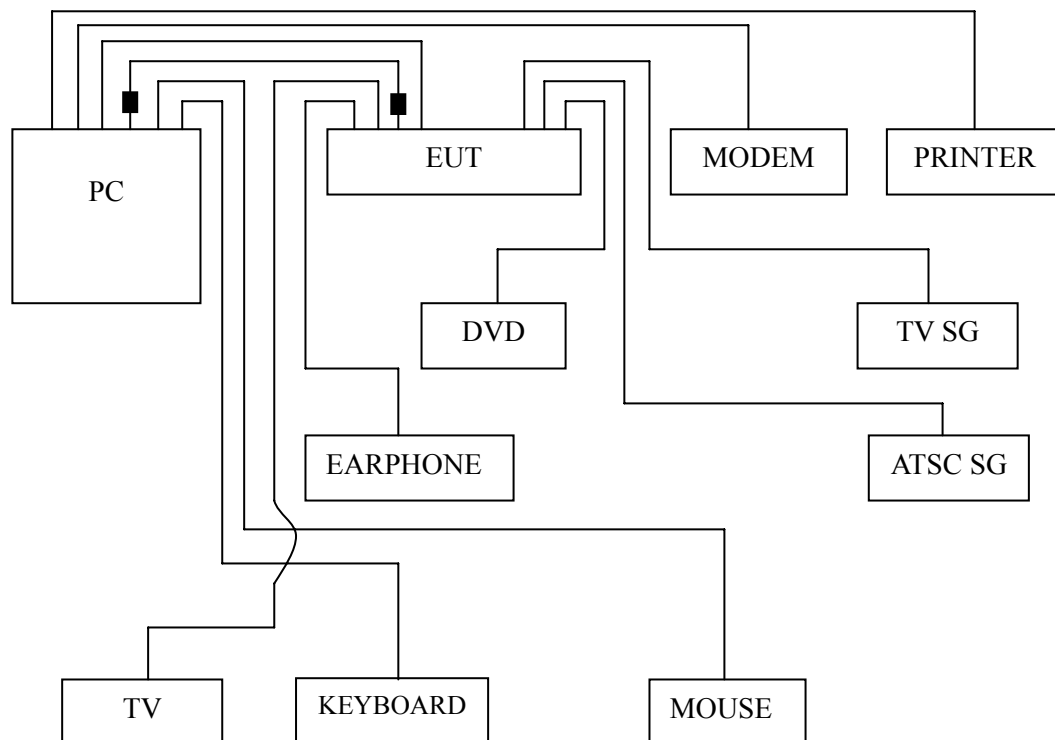

■ : Ferrite core

4.2.2 Radiated emission test setup

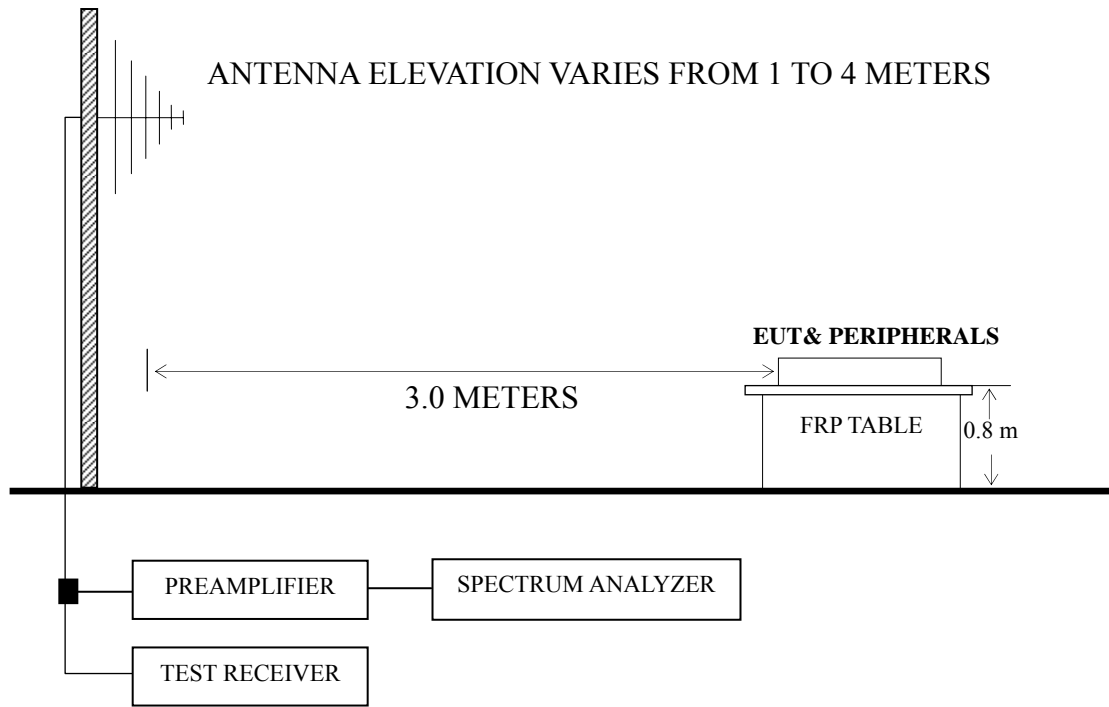

■ : 50 ohm Coaxial Switch

4.3 Radiated Emission Limit [FCC Part 15 Subpart B 15.109(a)]

Frequency (MHz)	Distance (m)	Field strength limits	
		($\mu\text{V/m}$)	dB ($\mu\text{V/m}$)
30 ~ 88	3	100	40.0
88 ~ 216	3	150	43.5
216 ~ 960	3	200	46.0
Above 960	3	500	54.0

NOTE 1 - Emission Level dB ($\mu\text{V/m}$) = 20 log Emission Level ($\mu\text{V/m}$)

NOTE 2 - The tighter limit applies at the band edges.

NOTE 3 - Distance refers to the distance in meters between the measuring instrument antenna and the closed point of any part of the device or system.

NOTE 4 - The limits shown are based on Quasi-peak value detector.

4.4 Test Configuration

The configuration of the EUT and peripherals are same as those used in conducted emission test.

Please refer to Sec.3.4.

4.5 Operating Condition of EUT

Same as conducted emission test which is listed in Sec.3.5, except for the test setup replaced by Sec.4.2.

4.6 Test Procedures

The EUT and peripherals were placed on a FRP turntable that is 0.8 meter above ground. The FRP turntable rotated 360 degrees to determine the position of the maximum emission level. The EUT was set 3 meters away from the receiving antenna, which was mounted on an antenna tower. Broadband antenna (Calibrated Bilog Antenna) was used as receiving antenna. The antenna moved up and down between 1 meter and 4 meters to find out the maximum emission level. Both horizontal and vertical polarizations of the antenna were set on measurement. In order to find the maximum emission, all of the interference cables were manipulated according to ANSI C63.4:2003 requirements during radiated emission test.

The bandwidth of Test Receiver R&S ESVS10 was set at 120 kHz.

The frequency range from 30 MHz to 1000MHz was checked for all test modes.

The test modes were done on radiated disturbance test and all the test results are listed in Sec.4.7.

4.7 Test Results

<PASS>

The frequency and amplitude of the highest radiated emission relative the limit is reported. All the emissions not reported below are too low against the FCC limit.

Test Mode	Data Page
D-Sub 640*480@60Hz	P22
D-Sub 1024*768@60Hz	P23
D-Sub 1360*768@60Hz	P24
HDMI 640*480@60Hz	P25
HDMI 1024*768@60Hz	P26
HDMI 1360*768@60Hz	P27

NOTE 1 – Emission Level = Antenna Factor + Cable Loss + Meter Reading.

NOTE 2 – The emission levels that are 20dB below the official limit are not reported.

NOTE 3 – 0° was the table front facing the antenna. Degree is calculated from 0° clockwise facing the antenna.

NOTE 4 – The worst case is for D-Sub 1360*768@60Hz test mode. The worst emission at horizontal polarization was detected at 174.530 MHz with corrected signal level of 38.24dB (μ V/m) (limit is 43.50dB (μ V/m)), when the antenna was 1.00 m height and the turntable was at 80°. The worst emission at vertical polarization was detected at 87.230 MHz with corrected signal level of 37.51dB (μ V/m) (limit is 40.00 dB (μ V/m)), when the antenna was 1.00 m height and the turntable was at 330°.

EUT : LCD TV Temperature : 22°C

Model No. : LCD19W57ACA Humidity : 60%RH

Serial No. : E2010062501 Date of Test : Jun 28, 2010

Test Mode : D-Sub 640*480@60Hz

Polarization	Frequency (MHz)	Meter Reading dB (μV)	Antenna Factor (dB/m)	Cable Loss (dB)	Emission Level dB (μV/m)	Limits dB (μV/m)	Margin (dB)
Horizontal	87.230	22.48	8.96	0.98	32.42	40.00	7.58
	174.530	27.54	10.07	1.35	38.96	43.50	4.54
	216.240	20.18	11.43	1.50	33.11	46.00	12.89
	300.630	17.46	13.93	1.77	33.16	46.00	12.84
	497.540	9.51	17.88	2.26	29.65	46.00	16.35
	649.830	12.60	19.45	2.57	34.62	46.00	11.38
Vertical	36.790	17.59	15.80	0.69	34.08	40.00	5.92
	87.230	26.53	8.96	0.98	36.47	40.00	3.53
	94.990	24.02	10.45	1.02	35.49	43.50	8.01
	153.190	23.96	11.04	1.25	36.25	43.50	7.25
	174.530	24.01	10.07	1.35	35.43	43.50	8.07
	737.130	12.93	20.07	2.78	35.78	46.00	10.22

TEST ENGINEER: RAVEN JIN

EUT : LCD TV Temperature : 22°C

Model No. : LCD19W57ACA Humidity : 60%RH

Serial No. : E2010062501 Date of Test : Jun 28, 2010

Test Mode : D-Sub1024*768@60Hz

Polarization	Frequency (MHz)	Meter Reading dB (µV)	Antenna Factor (dB/m)	Cable Loss (dB)	Emission Level dB (µV/m)	Limits dB (µV/m)	Margin (dB)
Horizontal	87.230	16.71	8.96	0.98	26.65	40.00	13.35
	174.530	27.63	10.07	1.35	39.05	43.50	4.45
	300.630	18.62	13.93	1.77	34.32	46.00	11.68
	514.030	12.12	18.06	2.29	32.47	46.00	13.53
	710.940	13.55	19.82	2.70	36.07	46.00	9.93
	997.090	16.07	22.37	4.49	42.93	54.00	11.07
Vertical	31.940	13.72	18.49	0.65	32.86	40.00	7.14
	43.580	19.47	11.88	0.74	32.09	40.00	7.91
	87.230	26.88	8.96	0.98	36.82	40.00	3.18
	153.190	23.84	11.04	1.25	36.13	43.50	7.37
	174.530	24.78	10.07	1.35	36.20	43.50	7.30
	240.490	18.59	12.56	1.58	32.73	46.00	13.27

TEST ENGINEER: RAVEN JIN

EUT : LCD TV Temperature : 22°C

Model No. : LCD19W57ACA Humidity : 60%RH

Serial No. : E2010062501 Date of Test : Jun 28, 2010

Test Mode : D-Sub 1360*768@60Hz

Polarization	Frequency (MHz)	Meter Reading dB (μV)	Antenna Factor (dB/m)	Cable Loss (dB)	Emission Level dB (μV/m)	Limits dB (μV/m)	Margin (dB)
Horizontal	87.230	16.93	8.96	0.98	26.87	40.00	13.13
	174.530	26.82	10.07	1.35	38.24	43.50	5.26
	300.630	18.43	13.93	1.77	34.13	46.00	11.87
	516.940	11.77	18.12	2.29	32.18	46.00	13.82
	662.440	12.16	19.52	2.59	34.27	46.00	11.73
	994.180	14.95	22.37	4.25	41.57	54.00	12.43
Vertical	36.790	18.18	15.80	0.69	34.67	40.00	5.33
	87.230	27.57	8.96	0.98	37.51	40.00	2.49
	153.190	23.77	11.04	1.25	36.06	43.50	7.44
	174.530	26.31	10.07	1.35	37.73	43.50	5.77
	342.340	15.19	15.11	1.90	32.20	46.00	13.80
	735.190	14.56	20.07	2.78	37.41	46.00	8.59

TEST ENGINEER: RAVEN JIN

EUT : LCD TV Temperature : 22°C

Model No. : LCD19W57ACA Humidity : 60%RH

Serial No. : E2010062501 Date of Test : Jun 28, 2010

Test Mode : HDMI 640*480@60Hz

Polarization	Frequency (MHz)	Meter Reading dB (μ V)	Antenna Factor (dB/m)	Cable Loss (dB)	Emission Level dB (μ V/m)	Limits dB (μ V/m)	Margin (dB)
Horizontal	87.230	15.97	8.96	0.98	25.91	40.00	14.09
	174.530	26.50	10.07	1.35	37.92	43.50	5.58
	300.630	18.87	13.93	1.77	34.57	46.00	11.43
	514.030	11.92	18.06	2.29	32.27	46.00	13.73
	662.440	11.26	19.52	2.59	33.37	46.00	12.63
	994.180	16.31	22.37	4.25	42.93	54.00	11.07
Vertical	36.790	15.45	15.80	0.69	31.94	40.00	8.06
	87.230	26.71	8.96	0.98	36.65	40.00	3.35
	153.190	22.19	11.04	1.25	34.48	43.50	9.02
	174.530	24.34	10.07	1.35	35.76	43.50	7.74
	502.390	13.14	17.93	2.26	33.33	46.00	12.67
	712.880	11.63	19.82	2.70	34.15	46.00	11.85

TEST ENGINEER: RAVEN JIN

EUT : LCD TV Temperature : 22°C

Model No. : LCD19W57ACA Humidity : 60%RH

Serial No. : E2010062501 Date of Test : Jun 28, 2010

Test Mode : HDMI 1024*768@60Hz

Polarization	Frequency (MHz)	Meter Reading dB (μ V)	Antenna Factor (dB/m)	Cable Loss (dB)	Emission Level dB (μ V/m)	Limits dB (μ V/m)	Margin (dB)
Horizontal	30.970	2.93	19.03	0.64	22.60	40.00	17.40
	87.230	16.20	8.96	0.98	26.14	40.00	13.86
	174.530	26.45	10.07	1.35	37.87	43.50	5.63
	300.630	17.81	13.93	1.77	33.51	46.00	12.49
	516.940	10.83	18.12	2.29	31.24	46.00	14.76
	715.790	12.80	19.85	2.72	35.37	46.00	10.63
Vertical	36.790	17.66	15.80	0.69	34.15	40.00	5.85
	72.680	22.95	6.85	0.91	30.71	40.00	9.29
	153.190	24.45	11.04	1.25	36.74	43.50	6.76
	240.490	17.96	12.56	1.58	32.10	46.00	13.90
	318.090	14.41	14.39	1.83	30.63	46.00	15.37
	502.390	13.46	17.93	2.26	33.65	46.00	12.35

TEST ENGINEER: RAVEN JIN

EUT : LCD TV Temperature : 22°C

Model No. : LCD19W57ACA Humidity : 60%RH

Serial No. : E2010062501 Date of Test : Jun 28, 2010

Test Mode : HDMI 1360*768@60Hz

Polarization	Frequency (MHz)	Meter Reading dB (μ V)	Antenna Factor (dB/m)	Cable Loss (dB)	Emission Level dB (μ V/m)	Limits dB (μ V/m)	Margin (dB)
Horizontal	87.230	16.50	8.96	0.98	26.44	40.00	13.56
	174.530	26.95	10.07	1.35	38.37	43.50	5.13
	305.480	18.27	14.07	1.78	34.12	46.00	11.88
	599.390	11.67	19.20	2.46	33.33	46.00	12.67
	710.940	11.30	19.82	2.70	33.82	46.00	12.18
	992.240	17.05	22.35	4.25	43.65	54.00	10.35
Vertical	36.790	18.45	15.80	0.69	34.94	40.00	5.06
	87.230	26.53	8.96	0.98	36.47	40.00	3.53
	94.990	22.37	10.45	1.02	33.84	43.50	9.66
	153.190	23.58	11.04	1.25	35.87	43.50	7.63
	174.530	23.34	10.07	1.35	34.76	43.50	8.74
	997.090	13.17	22.37	4.49	40.03	54.00	13.97

TEST ENGINEER: RAVEN JIN

5 DEVIATION TO TEST SPECIFICATIONS

None.

6 DEBUG DESCRIPTION

The following components are used during the countermeasure procedures:

Name	M/N	Specifications (mm)	Manufacturer	Location
Ferrite Core	BNF-12\ZCAT1 519-0830	15*19*8	FEELUX	See Internal Figure 15, 16
			Rui Feng Electronic Co., Ltd.	
			Hai An Magnetic Material No.2 Factory	

Note: We had required the applicant and manufacturer that all electrical and mechanical devices employed for spurious radiation suppression, including any modifications made during certification testing, must be incorporated in each unit marked

TEST ENGINEER:



(RAVEN JIN)