

Application for FCC Certificate
On Behalf of
Hisense Electric Co., Ltd.

LCD TV

Model No.	Serial No.	Brand
LHD32W57US	E2009052201	Hisense
LHD32W58US, LHDN32W57US	--	
LHDN32W58US, LHDN32W60US	--	
LHDN32W61US, LHD32W60US	--	
32LC30S57, 32LC30S60, 32LC30S61	--	Proscan
ELCHW321	--	Element

FCC ID : W9H32LCD001

Prepared For : Hisense Electric Co., Ltd.
No.218 Qianwangang Road, Economy & Technology
Development Zone, Qingdao, China

Prepared By : Audix Technology (Shanghai) Co., Ltd.
3F 34Bldg 680 Guiping Rd,
Caohejing Hi-Tech Park,
Shanghai 200233, China

Tel: +86-21-64955500
Fax: +86-21-64955491

Report No. : ACI-F09048
Date of Test : Jun 02 – 06, 2009
Date of Report : Jun 10, 2009

TABLE OF CONTENTS

	Page
1 SUMMARY OF STANDARDS AND RESULTS	4
1.1 Description of Standards and Results.....	4
2 GENERAL INFORMATION	5
2.1 Description of Equipment Under Test.....	5
2.2 Peripherals.....	7
2.3 Description of Test Facility.....	8
2.4 Measurement Uncertainty.....	8
3 CONDUCTED EMISSION TEST	9
3.2 Block Diagram of Test Setup.....	9
3.3 Conducted Emission Limit [FCC Part 15 Subpart B 15.107(a)].....	10
3.4 Test Configuration.....	10
3.5 Operating Condition of EUT.....	11
3.6 Test Procedures.....	11
3.7 Test Results.....	12
4 RADIATED EMISSION TEST	21
4.1 Test Equipment.....	21
4.2 Block Diagram of Test Setup.....	21
4.3 Radiated Emission Limit [FCC Part 15 Subpart B 15.109(a)].....	22
4.4 Test Configuration.....	22
4.5 Operating Condition of EUT.....	23
4.6 Test Procedures.....	23
4.7 Test Results.....	24
5 DEVIATION TO TEST SPECIFICATIONS	33
6 DEBUG DESCRIPTION	34

TEST REPORT FOR FCC CERTIFICATE

Applicant : Hisense Electric Co., Ltd.
 Manufacturer : Hisense Electric Co., Ltd.
 EUT Description : LCD TV

Model No.	Serial No.	Brand	Power Supply
LHD32W57US	E2009052201	Hisense	120V/60Hz
LHD32W58US, LHDN32W57US	--		
LHDN32W58US, LHDN32W60US	--		
LHDN32W61US, LHD32W60US	--		
32LC30S57, 32LC30S60, 32LC30S61	--	Proscan	
ELCHW321	--	Element	

Test Procedure Used:

*FCC RULES AND REGULATIONS PART 15 SUBPART B CLASS B OCTOBER 2008
AND ANSI C63.4-2003*

The device described above is tested by Audix Technology (Shanghai) Co., Ltd. to determine the maximum emission levels emanating from the device. The maximum emission levels are compared to the FCC Part 15 Subpart B (Class B) limits both radiated and conducted emissions.

The test results are contained in this test report and Audix Technology (Shanghai) Co., Ltd. is assumed full responsibility for the accuracy and completeness of these measurements. This report shows that the EUT (M/N: Refer to Sec.2.1; S/N: Refer to Sec.2.1) which was tested in 3m anechoic chamber Jun 02 – 06, 2009 is technically compliance with the FCC official limits also.

This report applies to above tested sample only. This report shall not be reproduced in part without written approval of Audix Technology (Shanghai) Co., Ltd.

This report contains data that are not covered by the NVLAP accreditation.

This report must not be used by the client to claim product certification, approval, or endorsement by NVLAP, NIST, or any agency of the federal government.

The test results for EUT's TV function are contained in No.F09047, a Verification report. Because of the request from the client that, the EUT use different LCD Panel & power board from the original model (The original Test Report No.: ACI-F09031). We reissue the report on the basis of the new sample.

Date of Test : Jun 02 – 06, 2009 Date of Report : Jun 10, 2009

Producer : Zeno Gu
ZENO GU / Assistant

Review : Byron WU
BYRON WU / Supervisor

 For and on behalf of
Audix Technology (Shanghai) Co., Ltd.

Signatory : Dio Yang
Authorized Signature EMC DIO YANG / Supervisor

1 SUMMARY OF STANDARDS AND RESULTS

1.1 Description of Standards and Results

The EUT have been tested according to the applicable standards as referenced below:

Description of Test Item	Standard	Limits	Results
EMISSION			
Conducted Disturbance at the Mains Terminal	FCC RULES AND REGULATIONS PART 15 SUBPART B OCTOBER 2008 AND ANSI C63.4-2003	15.107(a) Class B	Pass
Radiated Disturbance	FCC RULES AND REGULATIONS PART 15 SUBPART B OCTOBER 2008 AND ANSI C63.4-2003	15.109(a) Class B	Pass

2 GENERAL INFORMATION

2.1 Description of Equipment Under Test

Description : LCD TV

Type of EUT : Production Pre-product Pro-type

Model No.	Serial No.	Brand
LHD32W57US	E2009052201	Hisense
LHD32W58US, LHDN32W57US	--	
LHDN32W58US, LHDN32W60US	--	
LHDN32W61US, LHD32W60US	--	
32LC30S57, 32LC30S60, 32LC30S61	--	Proscan
ELCHW321	--	Element

Note 1 : The above models are all the same except for the different model number and brand.

Note 2 : The LHD32W57US was tested and recorded in this report.

Applicant : Hisense Electric Co., Ltd.
No.218 Qianwangang Road, Economy & Technology Development Zone, Qingdao, China

Manufacturer : Hisense Electric Co., Ltd.
No.218 Qianwangang Road, Economy & Technology Development Zone, Qingdao, China

LCD Panel : Manufacturer : Hisense
M/N : HC315BH-D01

Tuner : Manufacturer : SAMSUNG
M/N : DTVS205FH201A

Max Resolution : 1360*768@60Hz

D-Sub Cable : Shielded, Detachable, 1.85m,
with two cores on cable

HDMI Cable : Shielded, Detachable, 1.85m,
without core on cable

Power Cord : Unshielded, Detachable, 1.80m

Remark:

The EUT is a LCD TV which input/output ports as follows:

Rear View:

- | | | |
|-----|------------------------------------|--------------------------|
| (1) | One HDMI1 Port | Connected with DVD #1/PC |
| (2) | One HDMI2 Port | Connected with DVD #2/PC |
| (3) | One VGA Port | Connected with PC |
| (4) | One VGA Audio In Port | Connected with PC |
| (5) | One component of YPbPr1 Port | Connected with DVD #1 |
| (6) | One component of YPbPr1 Audio Port | Connected with DVD #1 |
| (7) | One component of YPbPr2 Port | Connected with DVD #2 |
| (8) | One component of YPbPr2 Audio Port | Connected with DVD #2 |
| (9) | One component of AV Out Port | Connected with TV |

Side Port:

- | | | |
|------|--------------------------|------------------------------|
| (10) | One component of AV Port | Connected with DVD #1 |
| (11) | One S-Video Port | Connected with TV SG/ATSC SG |
| (12) | One Earphone Port | Connected with Earphone |
| (13) | One ANT Port | Connected with TV SG/ATSC SG |
| (14) | One Coaxial Port | Connected with TV |

2.2 Peripherals

2.2.1 PC

Manufacturer : HP
Model Number : dx7200MT
Serial Number : CNG622017W
Power Cord : Unshielded, Detachable, 1.8m
Certificate : FCC DoC; CE/EMC; VCCI; C-Tick; UL
BSMI (R33001) 3C (A000111)
MIC (E-A011-04-2659(B))

2.2.2 Printer

Manufacturer : HP
Model Number : C3990A
Serial Number : JPZX020487
Data Cable : Shielded, detachable, 1.5m
Certificate : GS, CE/EMC, C-Tick, FCC DoC

2.2.3 Keyboard

Manufacturer : Microsoft
Model Number : RT2300
Serial Number : 7668200662248
Data Cable : Shielded, undetachable ,1.8m
Certificate : CE/EMC, FCC DoC, VCCI, MIC, C-Tick,
BSMI

2.2.4 Mouse

Manufacturer : Microsoft
Model Number : RT2300
Serial Number : 6965712071551
Data Cable : Shielded, undetachable, 1.8m.
Certificate : CE/EMC, FCC DoC, VCCI, MIC, C-Tick,
BSMI

2.2.5 Modem

Manufacturer : TP-LINK
Model Number : TM-EC5658V
Serial Number : 07123301053
Data Cable : Shielded, Detachable, 1.8m
Certificate : FCC DoC, CE/EMC, CCC

2.2.6 Earphone

Manufacturer : SONY
Model Number : MDR-E808
Serial Number : 1808030805305506

2.2.7 TV

Manufacturer : SOYEA
Model Number : V1453 (M)
Data Cable : Unshielded, Undetachable, 1.5m
Certificate : FCC DoC, CE/EMC, CCC

2.2.8 TV Signal Generator

Manufacturer : FLUKE
Model Number : 54200m01
Serial Number : 814008
Data Cable : Shielded, detachable, 2.0m
Power Cord : Unshielded, detachable, 2.0m
Certificate : CE/EMC, FCC DoC, CCC

2.2.9 ATSC Signal Generator

Manufacturer : SENCORE
Model Number : ATSC997
Serial Number : 6790071

2.2.10 DVD#1

Manufacturer : PHILIPS
Model Number : DVP3986K/93
Serial Number : KX1A0902120108
Certificate : FCC DoC, CE/EMC, CCC

2.2.11 DVD#2

Manufacturer : PHILIPS
Model Number : DVP3986K/93
Serial Number : KX1A0902120082
Certificate : FCC DoC, CE/EMC, CCC

2.3 Description of Test Facility

Site Description (Semi-Anechoic Chamber) : Sept. 17, 1998 file on
Apr 29, 2009 Renewed
Federal Communications Commission
FCC Engineering Laboratory
7435 Oakland Mills Road
Columbia, MD 21046, USA

Name of Firm : Audix Technology (Shanghai) Co., Ltd.

Site Location : 3F 34Bldg 680 Guiping Rd,
Caohejing Hi-Tech Park,
Shanghai 200233, China

NVLAP Lab Code : 200371-0

2.4 Measurement Uncertainty

Conducted Emission Expanded Uncertainty: U = 1.26 dB
Radiated Emission Expanded Uncertainty : U = 3.02 dB

3 CONDUCTED EMISSION TEST

3.1.1 Test Equipment

The following test equipments are used during the conducted emission test in a shielded room:

Item	Type	Manufacturer	Model No.	Serial No.	Last Cal.	Next Cal.
1.	Test Receiver	R&S	ESCI	100841	Nov 21, 2008	Nov 21, 2009
2.	Artificial Mains Network (AMN)	R&S	ESH2-Z5	843890/011	Apr 02, 2009	Apr 02, 2010
3.	Line Impedance Stabilization Network (LISN)	Kyoritsu	KNW-407	8-1280-4	Apr 02, 2009	Apr 02, 2010
4.	50 Ω Coaxial Switch	Anritsu	MP59B	6200426389	Mar 19, 2009	Sep 19, 2009
5.	50 Ω Terminator	Anritsu	BNC	001	Apr 02, 2009	Apr 02, 2010
6.	Software	Audix	E3	SET00200 9804M592	--	--

3.2 Block Diagram of Test Setup

3.2.1 EUT & Peripherals

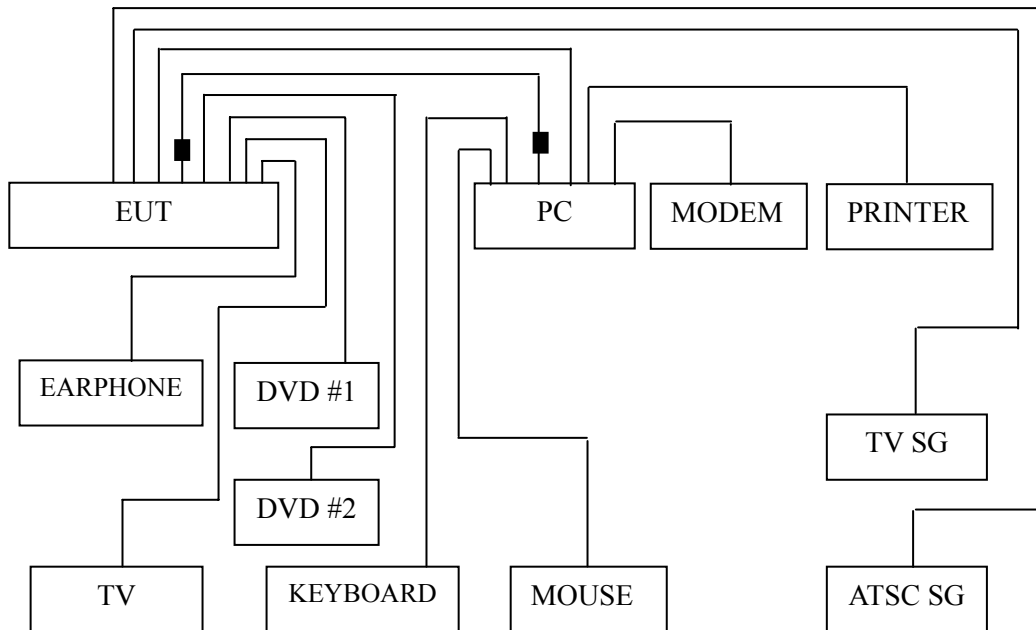

■ : Ferrite core

3.2.2 Conducted Disturbance Test Setup

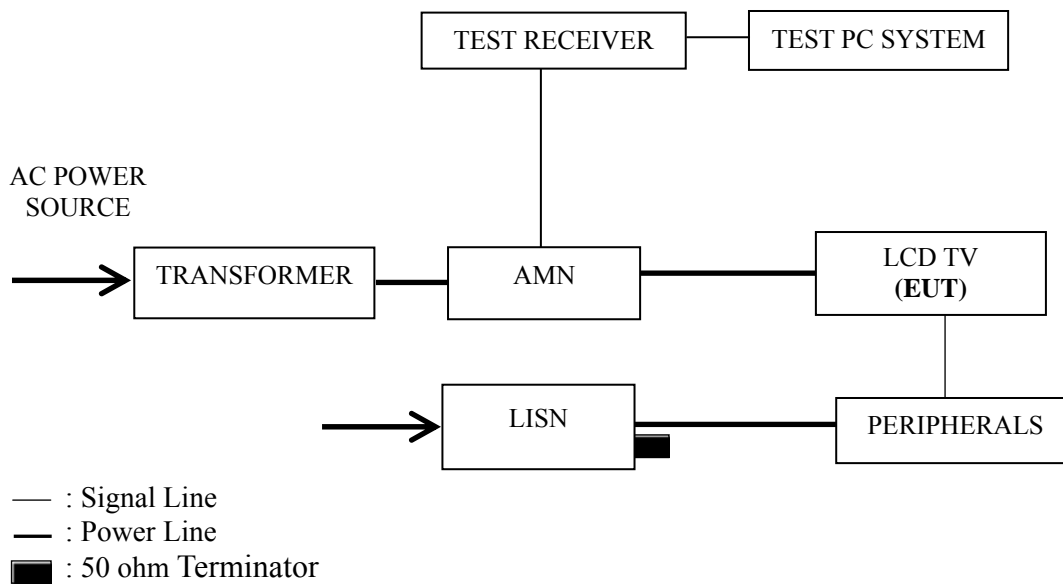

3.3 Conducted Emission Limit [FCC Part 15 Subpart B 15.107(a)]

Frequency Range (MHz)	Limits dB (μ V)	
	Quasi-peak	Average
0.15 ~ 0.5	66~56	56~46
0.5 ~ 5	56	46
5 ~ 30	60	50

NOTE 1 – The lower limit shall apply at the transition frequencies.
 NOTE 2 – The limit decreases linearly with the logarithm of the frequency in the range 0.15 MHz~0.50 MHz

3.4 Test Configuration

The EUT (listed in Sec.2.1) and the peripherals (listed in Sec 2.2) were installed as shown on Sec.3.2 to meet FCC requirement and operating in a manner that tends to maximize its emission level in a normal application.

3.5 Operating Condition of EUT

3.5.1 Setup the EUT and peripherals as shown in Sec. 3.2.

3.5.2 Turn on the power of all equipments and the EUT.

3.5.3 Set the contrast & brightness of EUT to maximum.

3.5.4 PC system ran the self-test program “EMC Test” by windows XP and sent “H” characters to EUT through graphic card, the EUT’s screen displayed and filled with “H” pattern by its resolution (Via D-Sub & HDMI Input).

3.5.5 Repeat above procedure from 3.5.3 to 3.5.4 for difference test mode.

3.5.6 The other peripherals devices were driven and operated during the test.

3.5.7 The test modes are as follows:

Test Mode
D-Sub 640*480@60Hz
D-Sub 800*600@60Hz
D-Sub 1024*768@60Hz
D-Sub 1360*768@60Hz
HDMI 640*480@60Hz
HDMI 800*600@60Hz
HDMI 1024*768@60Hz
HDMI 1360*768@60Hz

3.6 Test Procedures

The EUT and peripherals were connected to the power mains through an Artificial Mains Network (AMN). This provided a 50 ohm coupling impedance for the measuring equipment.

Both sides of AC line (Line & Neutral) were checked for maximum conducted interference. In order to find the maximum emission, the relative positions of equipment and all of the interface cables were changed or manipulated according to ANSI C63.4:2003 during conducted emission test.

The bandwidth of R&S Test Receiver ESCI was set at 9 kHz.

The frequency range from 150 kHz to 30 MHz was checked.

The test modes were done on conducted disturbance test and all the test results are listed in Sec. 3.7.

3.7 Test Results

< **PASS** >

The frequency and amplitude of the highest conducted emission relative to the limit is reported. All emissions not reported below are too low against the prescribed limits.

Test Mode	Data Page
D-Sub 640*480@60Hz	P13
D-Sub 800*600@60Hz	P14
D-Sub 1024*768@60Hz	P15
D-Sub 1360*768@60Hz	P16
HDMI 640*480@60Hz	P17
HDMI 800*600@60Hz	P18
HDMI 1024*768@60Hz	P19
HDMI 1360*768@60Hz	P20

NOTE 1 – Factor = Cable Loss + AMN Factor.

NOTE 2 – Emission Level = Meter Reading + Factor.

NOTE 3 – “QP” means “Quasi-Peak” values, “AV” means “Average” values.

NOTE 4 – The worst case is for HDMI 1360*768@60Hz test mode. The worst emission is detected at 21.600 MHz (Average) with corrected signal level of 30.46 dB (μ V) (limit is 50.00 dB (μ V)), when the Line of the EUT is connected to AMN.

EUT : LCD TV Temperature : 22°C

Model No. : LHD32W57US Humidity : 48%RH

Serial No. : E2009052201 Date of Test : Jun 06, 2009

Test Mode : D-Sub 640*480@60Hz

Test Line	Frequency (MHz)	Meter Reading dB(μ V)	Factor (dB)	Emission Level dB(μ V)	Limits dB(μ V)	Margin (dB)	Remark
Line	0.162	28.96	0.59	29.55	65.34	35.79	QP
	0.440	17.97	0.58	18.55	57.07	38.52	
	0.564	20.57	0.54	21.11	56.00	34.89	
	1.928	16.65	0.41	17.06	56.00	38.94	
	11.317	27.57	0.68	28.25	60.00	31.75	
	14.364	32.24	0.87	33.11	60.00	26.89	
	AV	0.162	18.75	0.59	19.34	55.34	36.00
		0.440	11.64	0.58	12.22	47.07	34.85
		0.564	10.65	0.54	11.19	46.00	34.81
		1.928	11.63	0.41	12.04	46.00	33.96
		11.317	17.64	0.68	18.32	50.00	31.68
		14.364	22.64	0.87	23.51	50.00	26.49
Neutral	0.159	27.27	0.47	27.74	65.52	37.78	QP
	0.274	18.77	0.57	19.34	60.98	41.64	
	1.433	18.24	0.45	18.69	56.00	37.31	
	3.293	16.77	0.45	17.22	56.00	38.78	
	12.784	30.45	0.75	31.20	60.00	28.80	
	14.364	32.45	0.77	33.22	60.00	26.78	
	AV	0.159	17.64	0.47	18.11	55.52	37.41
		0.274	11.35	0.57	11.92	50.98	39.06
		1.433	11.62	0.45	12.07	46.00	33.93
		3.293	9.64	0.45	10.09	46.00	35.91
		12.784	21.63	0.75	22.38	50.00	27.62
		14.364	23.57	0.77	24.34	50.00	25.66

TEST ENGINEER: HUGH HUANG

EUT : LCD TV Temperature : 22°C

Model No. : LHD32W57US Humidity : 48%RH

Serial No. : E2009052201 Date of Test : Jun 06, 2009

Test Mode : D-Sub 800*600@60Hz

Test Line	Frequency (MHz)	Meter Reading dB(μ V)	Factor (dB)	Emission Level dB(μ V)	Limits dB(μ V)	Margin (dB)	Remark
Line	0.159	28.82	0.58	29.40	65.52	36.12	QP
	0.440	18.34	0.58	18.92	57.07	38.15	
	0.564	21.00	0.54	21.54	56.00	34.46	
	1.184	18.32	0.46	18.78	56.00	37.22	
	10.564	30.37	0.62	30.99	60.00	29.01	
	12.124	31.41	0.74	32.15	60.00	27.85	
	0.159	18.64	0.58	19.22	55.52	36.30	AV
	0.440	11.64	0.58	12.22	47.07	34.85	
	0.564	11.39	0.54	11.93	46.00	34.07	
	1.184	10.34	0.46	10.80	46.00	35.20	
	10.564	20.64	0.62	21.26	50.00	28.74	
	12.124	21.63	0.74	22.37	50.00	27.63	
Neutral	0.159	26.66	0.47	27.13	65.52	38.39	QP
	0.273	18.58	0.57	19.15	61.03	41.88	
	1.184	17.73	0.46	18.19	56.00	37.81	
	3.293	17.02	0.45	17.47	56.00	38.53	
	14.364	32.15	0.77	32.92	60.00	27.08	
	18.232	29.41	0.88	30.29	60.00	29.71	
	0.159	16.34	0.47	16.81	55.52	38.71	AV
	0.273	11.26	0.57	11.83	51.03	39.20	
	1.184	11.64	0.46	12.10	46.00	33.90	
	3.293	10.64	0.45	11.09	46.00	34.91	
	14.364	22.64	0.77	23.41	50.00	26.59	
	18.232	19.64	0.88	20.52	50.00	29.48	

TEST ENGINEER: HUGH HUANG

EUT : LCD TV Temperature : 22°C

Model No. : LHD32W57US Humidity : 48%RH

Serial No. : E2009052201 Date of Test : Jun 06, 2009

Test Mode : D-Sub 1024*768@60Hz

Test Line	Frequency (MHz)	Meter Reading dB(μV)	Factor (dB)	Emission Level dB(μV)	Limits dB(μV)	Margin (dB)	Remark
Line	0.162	28.62	0.59	29.21	65.34	36.13	QP
	0.435	18.69	0.58	19.27	57.15	37.88	
	0.564	20.73	0.54	21.27	56.00	34.73	
	1.433	17.26	0.44	17.70	56.00	38.30	
	5.535	18.09	0.58	18.67	60.00	41.33	
	17.849	30.21	0.85	31.06	60.00	28.94	
	0.162	18.64	0.59	19.23	55.34	36.11	AV
	0.435	10.25	0.58	10.83	47.15	36.32	
	0.564	10.37	0.54	10.91	46.00	35.09	
	1.433	10.32	0.44	10.76	46.00	35.24	
	5.535	10.35	0.58	10.93	50.00	39.07	
	17.849	21.64	0.85	22.49	50.00	27.51	
Neutral	0.161	28.45	0.47	28.92	65.43	36.51	QP
	0.435	18.43	0.56	18.99	57.15	38.16	
	0.564	21.03	0.53	21.56	56.00	34.44	
	1.433	17.55	0.45	18.00	56.00	38.00	
	14.364	33.32	0.77	34.09	60.00	25.91	
	17.849	30.20	0.87	31.07	60.00	28.93	
	0.161	18.64	0.47	19.11	55.43	36.32	AV
	0.435	10.62	0.56	11.18	47.15	35.97	
	0.564	12.65	0.53	13.18	46.00	32.82	
	1.433	10.36	0.45	10.81	46.00	35.19	
	14.364	23.64	0.77	24.41	50.00	25.59	
	17.849	20.97	0.87	21.84	50.00	28.16	

TEST ENGINEER: HUGH HUANG

EUT : LCD TV Temperature : 22°C

Model No. : LHD32W57US Humidity : 48%RH

Serial No. : E2009052201 Date of Test : Jun 06, 2009

Test Mode : D-Sub 1360*768@60Hz

Test Line	Frequency (MHz)	Meter Reading dB(μ V)	Factor (dB)	Emission Level dB(μ V)	Limits dB(μ V)	Margin (dB)	Remark
Line	0.161	28.44	0.59	29.03	65.43	36.40	QP
	0.440	18.35	0.58	18.93	57.07	38.14	
	0.564	20.93	0.54	21.47	56.00	34.53	
	1.433	17.16	0.44	17.60	56.00	38.40	
	14.364	28.81	0.87	29.68	60.00	30.32	
	17.849	30.64	0.85	31.49	60.00	28.51	
	0.161	18.64	0.59	19.23	55.43	36.20	AV
	0.440	11.27	0.58	11.85	47.07	35.22	
	0.564	10.95	0.54	11.49	46.00	34.51	
	1.433	10.47	0.44	10.91	46.00	35.09	
	14.364	17.84	0.87	18.71	50.00	31.29	
	17.849	21.64	0.85	22.49	50.00	27.51	
Neutral	0.182	23.29	0.53	23.82	64.42	40.60	QP
	0.435	16.72	0.56	17.28	57.15	39.87	
	1.184	16.50	0.46	16.96	56.00	39.04	
	4.549	16.27	0.46	16.73	56.00	39.27	
	13.408	30.77	0.76	31.53	60.00	28.47	
	17.849	30.07	0.87	30.94	60.00	29.06	
	0.182	13.61	0.53	14.14	54.42	40.28	AV
	0.435	9.80	0.56	10.36	47.15	36.79	
	1.184	8.40	0.46	8.86	46.00	37.14	
	4.549	9.62	0.46	10.08	46.00	35.92	
	13.408	21.36	0.76	22.12	50.00	27.88	
	17.849	21.65	0.87	22.52	50.00	27.48	

TEST ENGINEER: HUGH HUANG

EUT : LCD TV Temperature : 22°C

Model No. : LHD32W57US Humidity : 48%RH

Serial No. : E2009052201 Date of Test : Jun 06, 2009

Test Mode : HDMI 640*480@60Hz

Test Line	Frequency (MHz)	Meter Reading dB(μ V)	Factor (dB)	Emission Level dB(μ V)	Limits dB(μ V)	Margin (dB)	Remark
Line	0.155	30.89	0.58	31.47	65.74	34.27	QP
	0.313	20.01	0.61	20.62	59.88	39.26	
	0.564	21.07	0.54	21.61	56.00	34.39	
	3.681	17.17	0.53	17.70	56.00	38.30	
	13.408	31.74	0.82	32.56	60.00	27.44	
	21.600	38.32	0.82	39.14	60.00	20.86	
	AV	0.155	20.35	0.58	20.93	55.74	34.81
		0.313	10.38	0.61	10.99	49.88	38.89
		0.564	11.35	0.54	11.89	46.00	34.11
		3.681	7.93	0.53	8.46	46.00	37.54
13.408		21.38	0.82	22.20	50.00	27.80	
21.600		28.49	0.82	29.31	50.00	20.69	
Neutral	0.156	29.32	0.46	29.78	65.65	35.87	QP
	0.313	18.91	0.57	19.48	59.88	40.40	
	1.184	18.02	0.46	18.48	56.00	37.52	
	2.309	16.08	0.44	16.52	56.00	39.48	
	13.551	34.89	0.77	35.66	60.00	24.34	
	21.600	37.74	0.92	38.66	60.00	21.34	
	AV	0.156	19.68	0.46	20.14	55.65	35.51
		0.313	8.67	0.57	9.24	49.88	40.64
		1.184	8.29	0.46	8.75	46.00	37.25
		2.309	6.29	0.44	6.73	46.00	39.27
13.551		24.67	0.77	25.44	50.00	24.56	
21.600	27.99	0.92	28.91	50.00	21.09		

TEST ENGINEER: HUGH HUANG

EUT : LCD TV Temperature : 22°C

Model No. : LHD32W57US Humidity : 48%RH

Serial No. : E2009052201 Date of Test : Jun 06, 2009

Test Mode : HDMI 800*600@60Hz

Test Line	Frequency (MHz)	Meter Reading dB(μ V)	Factor (dB)	Emission Level dB(μ V)	Limits dB(μ V)	Margin (dB)	Remark
Line	0.156	30.86	0.58	31.44	65.65	34.21	QP
	0.313	19.34	0.61	19.95	59.88	39.93	
	0.564	21.58	0.54	22.12	56.00	33.88	
	1.184	16.72	0.46	17.18	56.00	38.82	
	13.127	36.36	0.80	37.16	60.00	22.84	
	21.600	36.53	0.82	37.35	60.00	22.65	
	0.156	20.35	0.58	20.93	55.65	34.72	AV
	0.313	9.49	0.61	10.10	49.88	39.78	
	0.564	11.36	0.54	11.90	46.00	34.10	
	1.184	6.49	0.46	6.95	46.00	39.05	
	13.127	26.59	0.80	27.39	50.00	22.61	
	21.600	26.84	0.82	27.66	50.00	22.34	
Neutral	0.155	29.23	0.45	29.68	65.74	36.06	QP
	0.313	19.57	0.57	20.14	59.88	39.74	
	0.686	17.67	0.49	18.16	56.00	37.84	
	1.184	17.61	0.46	18.07	56.00	37.93	
	13.127	36.06	0.76	36.82	60.00	23.18	
	21.600	36.39	0.92	37.31	60.00	22.69	
	0.155	19.69	0.45	20.14	55.74	35.60	AV
	0.313	9.58	0.57	10.15	49.88	39.73	
	0.686	7.57	0.49	8.06	46.00	37.94	
	1.184	7.49	0.46	7.95	46.00	38.05	
	13.127	26.38	0.76	27.14	50.00	22.86	
	21.600	26.54	0.92	27.46	50.00	22.54	

TEST ENGINEER: HUGH HUANG

EUT : LCD TV Temperature : 22°C

Model No. : LHD32W57US Humidity : 48%RH

Serial No. : E2009052201 Date of Test : Jun 06, 2009

Test Mode : HDMI 1024*768@60Hz

Test Line	Frequency (MHz)	Meter Reading dB(μV)	Factor (dB)	Emission Level dB(μV)	Limits dB(μV)	Margin (dB)	Remark
Line	0.156	30.38	0.58	30.96	65.65	34.69	QP
	0.313	20.08	0.61	20.69	59.88	39.19	
	0.564	21.28	0.54	21.82	56.00	34.18	
	2.931	16.00	0.48	16.48	56.00	39.52	
	13.841	35.63	0.84	36.47	60.00	23.53	
	21.600	37.79	0.82	38.61	60.00	21.39	
	0.156	20.16	0.58	20.74	55.65	34.91	AV
	0.313	10.36	0.61	10.97	49.88	38.91	
	0.564	11.36	0.54	11.90	46.00	34.10	
	2.931	5.26	0.48	5.74	46.00	40.26	
	13.841	25.95	0.84	26.79	50.00	23.21	
	21.600	27.74	0.82	28.56	50.00	21.44	
Neutral	0.156	29.03	0.46	29.49	65.65	36.16	QP
	0.313	19.58	0.57	20.15	59.88	39.73	
	0.686	16.99	0.49	17.48	56.00	38.52	
	1.184	18.05	0.46	18.51	56.00	37.49	
	13.551	35.42	0.77	36.19	60.00	23.81	
	21.600	36.99	0.92	37.91	60.00	22.09	
	0.156	19.68	0.46	20.14	55.65	35.51	AV
	0.313	9.38	0.57	9.95	49.88	39.93	
	0.686	6.57	0.49	7.06	46.00	38.94	
	1.184	8.26	0.46	8.72	46.00	37.28	
	13.551	25.47	0.77	26.24	50.00	23.76	
	21.600	26.36	0.92	27.28	50.00	22.72	

TEST ENGINEER: HUGH HUANG

EUT : LCD TV Temperature : 22°C

Model No. : LHD32W57US Humidity : 48%RH

Serial No. : E2009052201 Date of Test : Jun 06, 2009

Test Mode : HDMI 1360*768@60Hz

Test Line	Frequency (MHz)	Meter Reading dB(μ V)	Factor (dB)	Emission Level dB(μ V)	Limits dB(μ V)	Margin (dB)	Remark
Line	0.156	30.29	0.58	30.87	65.65	34.78	QP
	0.313	19.34	0.61	19.95	59.88	39.93	
	0.564	20.97	0.54	21.51	56.00	34.49	
	2.931	16.95	0.48	17.43	56.00	38.57	
	13.841	34.81	0.84	35.65	60.00	24.35	
	21.600	38.94	0.82	39.76	60.00	20.24	
	0.156	21.64	0.58	22.22	55.65	33.43	AV
	0.313	11.24	0.61	11.85	49.88	38.03	
	0.564	11.33	0.54	11.87	46.00	34.13	
	2.931	10.64	0.48	11.12	46.00	34.88	
	13.841	24.65	0.84	25.49	50.00	24.51	
	21.600	29.64	0.82	30.46	50.00	19.54	
Neutral	0.156	28.48	0.46	28.94	65.65	36.71	QP
	0.313	19.63	0.57	20.20	59.88	39.68	
	1.184	19.03	0.46	19.49	56.00	36.51	
	3.293	17.31	0.45	17.76	56.00	38.24	
	13.989	33.09	0.77	33.86	60.00	26.14	
	21.600	38.63	0.92	39.55	60.00	20.45	
	0.156	18.64	0.46	19.10	55.65	36.55	AV
	0.313	11.64	0.57	12.21	49.88	37.67	
	1.184	11.94	0.46	12.40	46.00	33.60	
	3.293	10.64	0.45	11.09	46.00	34.91	
	13.989	23.64	0.77	24.41	50.00	25.59	
	21.600	28.64	0.92	29.56	50.00	20.44	

TEST ENGINEER: HUGH HUANG

4 RADIATED EMISSION TEST

4.1 Test Equipment

The following test equipments are used during the radiated emission test in a semi-anechoic chamber:

Item	Type	Manufacturer	Model No.	Serial No.	Last Cal.	Next Cal.
1.	Test Receiver	R&S	ESVS10	844594/001	Mar 07, 2009	Mar 07, 2010
2.	Preamplifier	Agilent	8447D	2944A10548	Mar 19, 2009	Sep 19, 2009
3.	Bi-log Antenna	TESEQ	CBL6112D	23193	May 14, 2009	May 14, 2010
4.	Spectrum	Agilent	E7405A	MY45106600	May 19, 2009	May 19, 2010
5.	Software	Audix	E3	SET00200 9912M295-2	--	--

4.2 Block Diagram of Test Setup

4.2.1 EUT and Peripherals

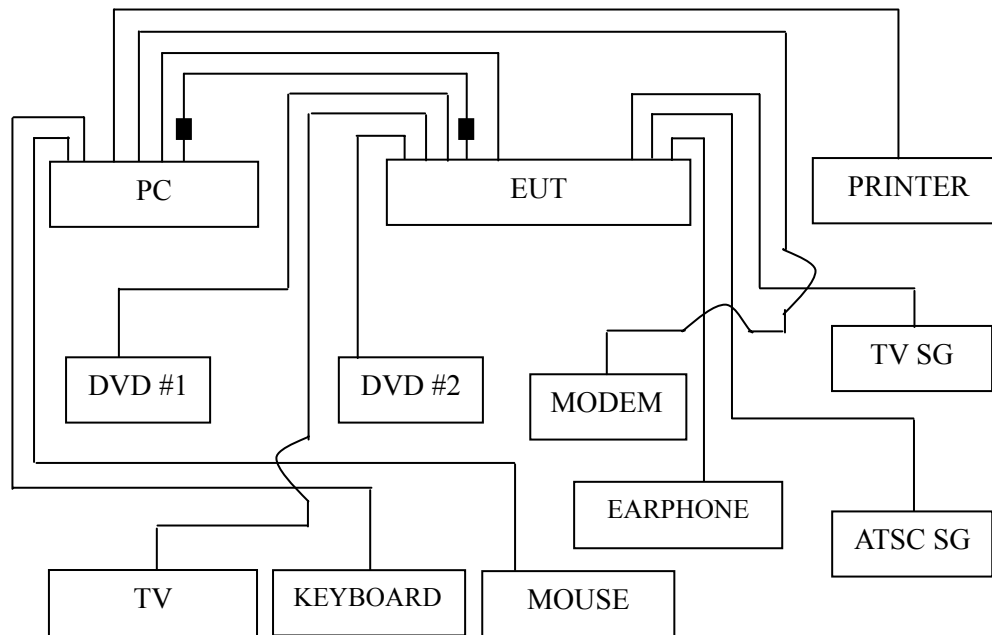

■ : Ferrite core

4.2.2 Radiated emission test setup

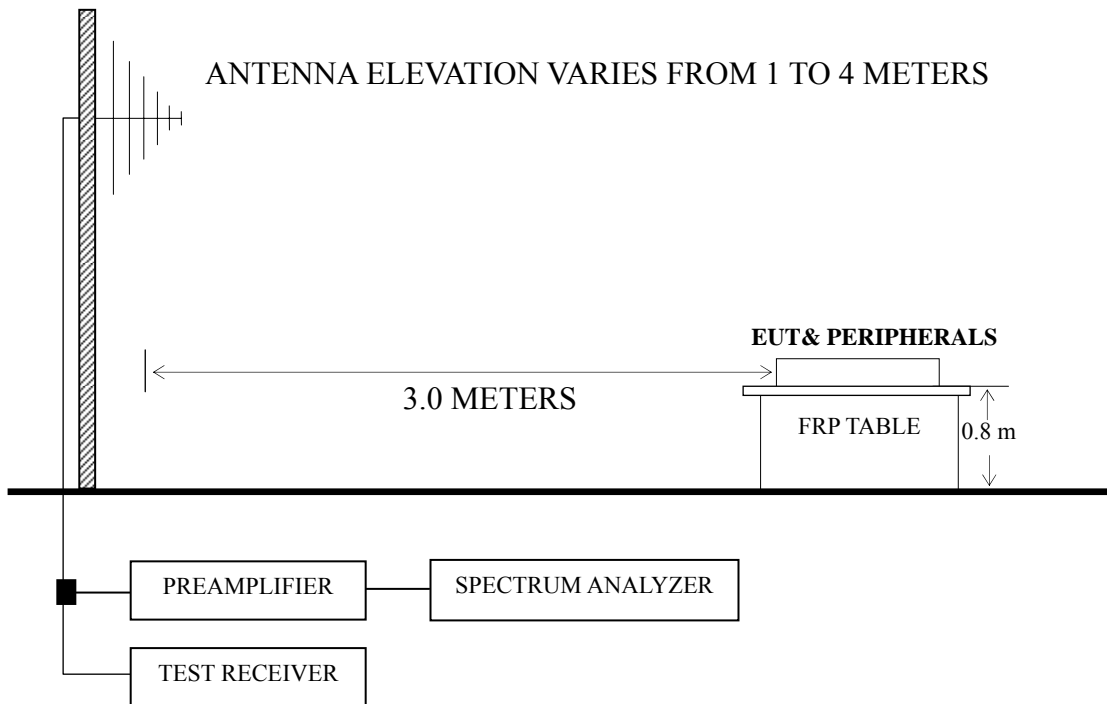

■ : 50 ohm Coaxial Switch

4.3 Radiated Emission Limit [FCC Part 15 Subpart B 15.109(a)]

Frequency (MHz)	Distance (m)	Field strength limits	
		($\mu\text{V}/\text{m}$)	dB ($\mu\text{V}/\text{m}$)
30 ~ 88	3	100	40.0
88 ~ 216	3	150	43.5
216 ~ 960	3	200	46.0
Above 960	3	500	54.0

NOTE 1 - Emission Level dB ($\mu\text{V}/\text{m}$) = 20 log Emission Level ($\mu\text{V}/\text{m}$)
 NOTE 2 - The tighter limit applies at the band edges.
 NOTE 3 - Distance refers to the distance in meters between the measuring instrument antenna and the closed point of any part of the device or system.
 NOTE 4 - The limits shown are based on Quasi-peak value detector below or equal to 1GHz.

4.4 Test Configuration

The configuration of the EUT and peripherals are same as those used in conducted emission test.

Please refer to Sec.3.4.

4.5 Operating Condition of EUT

Same as conducted emission test which is listed in Sec.3.5, except for the test setup replaced by Sec.4.2.

4.6 Test Procedures

The EUT and peripherals were placed on a FRP turntable that is 0.8 meter above ground. The FRP turntable rotated 360 degrees to determine the position of the maximum emission level. The EUT was set 3 meters away from the receiving antenna, which was mounted on an antenna tower. Broadband antenna (Calibrated Bilog Antenna) was used as receiving antenna. The antenna moved up and down between 1 meter and 4 meters to find out the maximum emission level. Both horizontal and vertical polarizations of the antenna were set on measurement. In order to find the maximum emission, all of the interference cables were manipulated according to ANSI C63.4:2003 requirements during radiated emission test.

The bandwidth of Test Receiver R&S ESVS10 was set at 120 kHz.

The frequency range from 30 MHz to 1000MHz was checked for all test modes.

The test modes were done on radiated disturbance test and all the test results are listed in Sec.4.7.

4.7 Test Results

<PASS>

The frequency and amplitude of the highest radiated emission relative the limit is reported. All the emissions not reported below are too low against the FCC limit.

Test Mode	Data Page
D-Sub 640*480@60Hz	P25
D-Sub 800*600@60Hz	P26
D-Sub 1024*768@60Hz	P27
D-Sub 1360*768@60Hz	P28
HDMI 640*480@60Hz	P29
HDMI 800*600@60Hz	P30
HDMI 1024*768@60Hz	P31
HDMI 1360*768@60Hz	P32

NOTE 1 – Emission Level = Antenna Factor + Cable Loss + Meter Reading.

NOTE 2 – The emission levels that are 20dB below the official limit are not reported.

NOTE 3 – 0° was the table front facing the antenna. Degree is calculated from 0° clockwise facing the antenna.

NOTE 4 – The worst case is for D-Sub 1360*768@60Hz test mode. The worst emission at horizontal polarization was detected at 199.750 MHz with corrected signal level of 42.24 dB ($\mu\text{V}/\text{m}$) (limit is 43.50dB ($\mu\text{V}/\text{m}$)), when the antenna was 2.00 m height and the turntable was at 70°. The worst emission at vertical polarization was detected at 57.160 MHz with corrected signal level of 38.18 dB ($\mu\text{V}/\text{m}$) (limit is 40.00 dB ($\mu\text{V}/\text{m}$)), when the antenna was 2.00 m height and the turntable was at 210°.

EUT : LCD TV Temperature : 22°C

Model No. : LHD32W57US Humidity : 60%RH

Serial No. : E2009052201 Date of Test : Jun 02, 2009

Test Mode : D-Sub 640*480@60Hz

Polarization	Frequency (MHz)	Meter Reading dB (μV)	Antenna Factor (dB/m)	Cable Loss (dB)	Emission Level dB (μV/m)	Limits dB (μV/m)	Margin (dB)
Horizontal	85.290	20.66	8.66	0.86	30.18	40.00	9.82
	104.690	19.21	11.88	0.86	31.95	43.50	11.55
	142.520	20.97	11.91	0.91	33.79	43.50	9.71
	209.450	21.38	11.13	1.12	33.63	43.50	9.87
	285.110	16.07	13.64	1.46	31.17	46.00	14.83
	522.760	8.76	18.21	2.43	29.40	46.00	16.60
Vertical	32.910	15.87	17.95	0.60	34.42	40.00	5.58
	53.280	28.06	8.14	0.79	36.99	40.00	3.01
	104.690	24.17	11.88	0.86	36.91	43.50	6.59
	114.390	25.56	12.64	0.87	39.07	43.50	4.43
	142.520	25.89	11.91	0.91	38.71	43.50	4.79
	199.750	26.48	10.67	1.08	38.23	43.50	5.27

TEST ENGINEER: RAVEN JIN

EUT : LCD TV Temperature : 22°C

Model No. : LHD32W57US Humidity : 60%RH

Serial No. : E2009052201 Date of Test : Jun 02, 2009

Test Mode : D-Sub 800*600@60Hz

Polarization	Frequency (MHz)	Meter Reading dB (μV)	Antenna Factor (dB/m)	Cable Loss (dB)	Emission Level dB (μV/m)	Limits dB (μV/m)	Margin (dB)
Horizontal	80.440	22.81	7.85	0.86	31.52	40.00	8.48
	114.390	21.70	12.64	0.87	35.21	43.50	8.29
	142.520	22.43	11.91	0.91	35.25	43.50	8.25
	199.750	29.42	10.67	1.08	41.17	43.50	2.33
	461.650	18.85	17.40	2.26	38.51	46.00	7.49
	608.120	19.46	19.25	2.63	41.34	46.00	4.66
Vertical	32.910	16.07	17.95	0.60	34.62	40.00	5.38
	53.280	27.08	8.14	0.79	36.01	40.00	3.99
	114.390	24.98	12.64	0.87	38.49	43.50	5.01
	142.520	25.84	11.91	0.91	38.66	43.50	4.84
	199.750	24.70	10.67	1.08	36.45	43.50	7.05
	809.880	18.13	20.80	3.34	42.27	46.00	3.73

TEST ENGINEER: RAVEN JIN

EUT : LCD TV Temperature : 22°C

Model No. : LHD32W57US Humidity : 60%RH

Serial No. : E2009052201 Date of Test : Jun 02, 2009

Test Mode : D-Sub 1024*768@60Hz

Polarization	Frequency (MHz)	Meter Reading dB (μV)	Antenna Factor (dB/m)	Cable Loss (dB)	Emission Level dB (μV/m)	Limits dB (μV/m)	Margin (dB)
Horizontal	104.690	22.42	11.88	0.86	35.16	43.50	8.34
	114.390	21.65	12.64	0.87	35.16	43.50	8.34
	142.520	21.15	11.91	0.91	33.97	43.50	9.53
	199.750	29.28	10.67	1.08	41.03	43.50	2.47
	608.120	21.07	19.25	2.63	42.95	46.00	3.05
	809.880	18.45	20.80	3.34	42.59	46.00	3.41
Vertical	55.220	28.60	7.69	0.80	37.09	40.00	2.91
	104.690	23.91	11.88	0.86	36.65	43.50	6.85
	114.390	25.34	12.64	0.87	38.85	43.50	4.65
	142.520	25.20	11.91	0.91	38.02	43.50	5.48
	199.750	25.64	10.67	1.08	37.39	43.50	6.11
	809.880	17.46	20.80	3.34	41.60	46.00	4.40

TEST ENGINEER: RAVEN JIN

EUT : LCD TV Temperature : 22°C

Model No. : LHD32W57US Humidity : 60%RH

Serial No. : E2009052201 Date of Test : Jun 02, 2009

Test Mode : D-Sub 1360*768@60Hz

Polarization	Frequency (MHz)	Meter Reading dB (μ V)	Antenna Factor (dB/m)	Cable Loss (dB)	Emission Level dB (μ V/m)	Limits dB (μ V/m)	Margin (dB)
Horizontal	82.380	26.90	8.19	0.96	36.05	40.00	3.95
	104.690	25.63	11.88	1.09	38.60	43.50	4.90
	114.390	26.65	12.64	1.13	40.42	43.50	3.08
	142.520	27.02	11.91	1.20	40.13	43.50	3.37
	199.750	30.03	10.67	1.54	42.24	43.50	1.26
	533.430	19.29	18.33	2.56	40.18	46.00	5.82
Vertical	53.280	28.64	8.14	0.79	37.57	40.00	2.43
	57.160	30.19	7.18	0.81	38.18	40.00	1.82
	104.690	24.26	11.88	0.86	37.00	43.50	6.50
	114.390	25.29	12.64	0.87	38.80	43.50	4.70
	142.520	25.52	11.91	0.91	38.34	43.50	5.16
	199.750	26.00	10.67	1.08	37.75	43.50	5.75

TEST ENGINEER: RAVEN JIN

EUT : LCD TV Temperature : 22°C

Model No. : LHD32W57US Humidity : 60%RH

Serial No. : E2009052201 Date of Test : Jun 02, 2009

Test Mode : HDMI 640*480@60Hz

Polarization	Frequency (MHz)	Meter Reading dB (μ V)	Antenna Factor (dB/m)	Cable Loss (dB)	Emission Level dB (μ V/m)	Limits dB (μ V/m)	Margin (dB)
Horizontal	79.470	21.37	7.72	0.86	29.95	40.00	10.05
	104.690	18.50	11.88	0.86	31.24	43.50	12.26
	142.520	21.63	11.91	0.91	34.45	43.50	9.05
	199.750	25.76	10.67	1.08	37.51	43.50	5.99
	285.110	14.82	13.64	1.46	29.92	46.00	16.08
	527.610	9.58	18.27	2.45	30.30	46.00	15.70
Vertical	32.910	17.00	17.95	0.60	35.55	40.00	4.45
	53.280	28.02	8.14	0.79	36.95	40.00	3.05
	58.130	29.33	6.96	0.82	37.11	40.00	2.89
	104.690	25.45	11.88	0.86	38.19	43.50	5.31
	114.390	25.43	12.64	0.87	38.94	43.50	4.56
	142.520	25.87	11.91	0.91	38.69	43.50	4.81

TEST ENGINEER: RAVEN JIN

EUT : LCD TV Temperature : 22°C

Model No. : LHD32W57US Humidity : 60%RH

Serial No. : E2009052201 Date of Test : Jun 02, 2009

Test Mode : HDMI 800*600@60Hz

Polarization	Frequency (MHz)	Meter Reading dB (μ V)	Antenna Factor (dB/m)	Cable Loss (dB)	Emission Level dB (μ V/m)	Limits dB (μ V/m)	Margin (dB)
Horizontal	104.690	49.36	11.88	0.86	33.76	43.50	9.74
	114.390	51.47	12.64	0.87	36.22	43.50	7.28
	142.520	52.44	11.91	0.91	37.27	43.50	6.23
	190.050	53.80	10.30	1.05	37.56	43.50	5.94
	199.750	57.12	10.67	1.08	41.36	43.50	2.14
	809.880	45.83	20.80	3.34	42.01	46.00	3.99
Vertical	104.690	24.23	11.88	0.86	36.97	43.50	6.53
	114.390	24.26	12.64	0.87	37.77	43.50	5.73
	124.090	21.64	12.81	0.89	35.34	43.50	8.16
	152.220	23.79	11.09	0.93	35.81	43.50	7.69
	199.750	25.86	10.67	1.08	37.61	43.50	5.89
	809.880	14.92	20.80	3.34	39.06	46.00	6.94

TEST ENGINEER: RAVEN JIN

EUT : LCD TV Temperature : 22°C

Model No. : LHD32W57US Humidity : 60%RH

Serial No. : E2009052201 Date of Test : Jun 02, 2009

Test Mode : HDMI 1024*768@60Hz

Polarization	Frequency (MHz)	Meter Reading dB (μ V)	Antenna Factor (dB/m)	Cable Loss (dB)	Emission Level dB (μ V/m)	Limits dB (μ V/m)	Margin (dB)
Horizontal	104.690	23.06	11.88	0.86	35.80	43.50	7.70
	114.390	23.43	12.64	0.87	36.94	43.50	6.56
	142.520	25.08	11.91	0.91	37.90	43.50	5.60
	199.750	27.67	10.67	1.08	39.42	43.50	4.08
	608.120	21.96	19.25	2.63	43.84	46.00	2.16
	809.880	18.55	20.80	3.34	42.69	46.00	3.31
Vertical	54.250	27.63	7.92	0.79	36.34	40.00	3.66
	114.390	26.80	12.64	0.87	40.31	43.50	3.19
	142.520	26.47	11.91	0.91	39.29	43.50	4.21
	199.750	26.17	10.67	1.08	37.92	43.50	5.58
	506.270	15.68	17.98	2.39	36.05	46.00	9.95
	809.880	17.82	20.80	3.34	41.96	46.00	4.04

TEST ENGINEER: RAVEN JIN

EUT : LCD TV Temperature : 22°C

Model No. : LHD32W57US Humidity : 60%RH

Serial No. : E2009052201 Date of Test : Jun 02, 2009

Test Mode : HDMI 1360*768@60Hz

Polarization	Frequency (MHz)	Meter Reading dB (μ V)	Antenna Factor (dB/m)	Cable Loss (dB)	Emission Level dB (μ V/m)	Limits dB (μ V/m)	Margin (dB)
Horizontal	105.660	29.02	11.95	0.86	41.83	43.50	1.67
	190.050	25.45	10.30	1.05	36.80	43.50	6.70
	199.750	29.84	10.67	1.08	41.59	43.50	1.91
	525.670	17.77	18.24	2.43	38.44	46.00	7.56
	608.120	20.12	19.25	2.63	42.00	46.00	4.00
	809.880	17.95	20.80	3.34	42.09	46.00	3.91
Vertical	32.910	13.34	17.95	0.60	31.89	40.00	8.11
	53.280	26.96	8.14	0.79	35.89	40.00	4.11
	104.690	24.22	11.88	0.86	36.96	43.50	6.54
	114.390	25.82	12.64	0.87	39.33	43.50	4.17
	142.520	26.60	11.91	0.91	39.42	43.50	4.08
	152.220	24.85	11.09	0.93	36.87	43.50	6.63

TEST ENGINEER: RAVEN JIN

5 DEVIATION TO TEST SPECIFICATIONS

None.

6 DEBUG DESCRIPTION

The following components are used during the countermeasure procedures:

Name	M/N	Specifications (mm)	Manufacturer	Location
Ferrite Core	TDK HF70RH	16*38*9	ROH	See Internal Photo Figure 15
Ferrite Core	TDK HF70RH	16*28*9	ROH	See Internal Photo Figure 16