



Prüfbericht-Nr.: <i>Test Report No.:</i>	50277818 001	Auftrags-Nr.: <i>Order No.:</i>	238107300	Seite 1 von 32 <i>Page 1 of 32</i>
Kunden-Referenz-Nr.: <i>Client Reference No.:</i>	N/A	Auftragsdatum: <i>Order date:</i>	02-Jul-2019	
Auftraggeber: <i>Client:</i>	Julius Blum GmbH Industriestrasse 1, 6973 Hoechst, Austria			
Prüfgegenstand: <i>Test item:</i>	Radio Switch			
Bezeichnung / Typ-Nr.: <i>Identification / Type No.:</i>	21P5020, 23P5020			
Auftrags-Inhalt: <i>Order content:</i>	FCC Part 15C Test report			
Prüfgrundlage: <i>Test specification:</i>	FCC 47CFR Part 15: Subpart C Section 15.247(DTS)			
Wareneingangsdatum: <i>Date of receipt:</i>	03-Jul-2019			
Prüfmuster-Nr.: <i>Test sample No.:</i>	A000951751-007 to 008			
Prüfzeitraum: <i>Testing period:</i>	09-Jul-2019 – 16-Jul-2019			
Ort der Prüfung: <i>Place of testing:</i>	EMC/RF Laboratory Taipei			
Prüflaboratorium: <i>Testing laboratory:</i>	TUV Rheinland Taiwan Ltd.			
Prüfergebnis*: <i>Test result*:</i>	Pass			
Report date / tested by:			kontrolliert von / reviewed by:	
18-Sep-2019 Brenda Chen/Project Manager			18-Sep-2019 Jack Chang/Project Manager	
Datum	Name / Stellung	Unterschrift	Datum	Name / Stellung
<i>Date</i>	<i>Name / Position</i>	<i>Signature</i>	<i>Date</i>	<i>Name / Position</i>
Sonstiges / Other:				
23P5020 has a button with symbols which are illuminated when the appropriate status is to be shown. 21P5020 has a simpler design without illuminated symbols.				
Zustand des Prüfgegenstandes bei Anlieferung: <i>Condition of the test item at delivery:</i>		Prüfmuster vollständig und unbeschädigt <i>Test item complete and undamaged</i>		
* Legende:	1 = sehr gut	2 = gut	3 = befriedigend	4 = ausreichend
	P(ass) = entspricht o.g. Prüfgrundlage(n)	F(ail) = entspricht nicht o.g. Prüfgrundlage(n)	N/A = nicht anwendbar	N/T = nicht getestet
Legend:	1 = very good	2 = good	3 = satisfactory	4 = sufficient
	P(ass) = passed a.m. test specification(s)	F(ail) = failed a.m. test specification(s)	N/A = not applicable	N/T = not tested
Dieser Prüfbericht bezieht sich nur auf das o.g. Prüfmuster und darf ohne Genehmigung der Prüfstelle nicht auszugsweise vervielfältigt werden. Dieser Bericht berechtigt nicht zur Verwendung eines Prüfzeichens. <i>This test report only relates to the a. m. test sample. Without permission of the test center this test report is not permitted to be duplicated in extracts. This test report does not entitle to carry any test mark.</i>				

TEST SUMMARY

5.1.1 ANTENNA REQUIREMENT

RESULT: *Passed*

5.1.2 MAXIMUM CONDUCTED PEAK OUTPUT POWER

RESULT: *Passed*

5.1.3 6dB BANDWIDTH

RESULT: *Passed*

5.1.4 POWER DENSITY

RESULT: *Passed*

5.1.5 CONDUCTED SPURIOUS EMISSIONS AND FREQUENCY BAND EDGE MEASURED IN 100KHZ BANDWIDTH

RESULT: *Passed*

5.1.6 SPURIOUS EMISSION

RESULT: *Passed*

6.1.1 ELECTROMAGNETIC FIELDS

RESULT: *Passed*

Contents

1.	GENERAL REMARKS	5
1.1	COMPLEMENTARY MATERIALS.....	5
1.2	DECISION RULE OF CONFORMITY.....	5
2.	TEST SITES	6
2.1	TEST LABORATORY	6
2.2	TEST FACILITY.....	6
2.3	LIST OF TEST AND MEASUREMENT INSTRUMENTS.....	7
2.4	TRACEABILITY	8
2.5	CALIBRATION	8
2.6	MEASUREMENT UNCERTAINTY.....	8
3.	GENERAL PRODUCT INFORMATION.....	9
3.1	PRODUCT FUNCTION AND INTENDED USE	9
3.2	SYSTEM DETAILS AND RATINGS.....	9
3.3	INDEPENDENT OPERATION MODES.....	10
3.4	NOISE GENERATING AND NOISE SUPPRESSING PARTS	10
3.5	SUBMITTED DOCUMENTS.....	10
4.	TEST SET-UP AND OPERATION MODES.....	11
4.1	PRINCIPLE OF CONFIGURATION SELECTION	11
4.2	TEST OPERATION AND TEST SOFTWARE.....	11
4.3	SPECIAL ACCESSORIES AND AUXILIARY EQUIPMENT	12
4.4	COUNTERMEASURES TO ACHIEVE EMC COMPLIANCE.....	12
4.5	TEST SETUP DIAGRAM	12
5.	TEST RESULTS	14
5.1	TRANSMITTER REQUIREMENT & TEST SUITES	14
5.1.1	<i>Antenna Requirement</i>	<i>14</i>
5.1.2	<i>Maximum conducted Peak output power.....</i>	<i>15</i>
5.1.3	<i>6dB Bandwidth</i>	<i>16</i>
5.1.4	<i>Power Density</i>	<i>19</i>
5.1.5	<i>Conducted spurious emissions and Frequency Band Edge measured in 100kHz Bandwidth.....</i>	<i>22</i>
5.1.6	<i>Spurious Emission</i>	<i>26</i>
6.	SAFETY HUMAN EXPOSURE	27
6.1	RADIO FREQUENCY EXPOSURE COMPLIANCE	27
6.1.1	<i>Electromagnetic Fields.....</i>	<i>27</i>

Produkte
Products

Prüfbericht - Nr.: 50277818 001
Test Report No.

Seite 4 von 32
Page 4 of 32

7.	PHOTOGRAPHS OF THE TEST SET-UP.....	28
8.	LIST OF TABLES	32
9.	LIST OF PHOTOGRAPHS.....	32

1. General Remarks

1.1 Complementary Materials

The following attachments are integral parts of this test report:

Appendix P: Photo Documentation internal view
(File Name: 50277818 001 APPENDIXP)

Appendix D: Test Result of Radiated Emissions
(File Name: 50277818 001 APPENDIXD)

Test Specifications

The following standards were applied.

Table 1: Applied Standard and Test Levels

Radio
FCC 47CFR Part 15: Subpart C Section 15.247
FCC 47CFR Part 2: Subpart J Section 2.1091
ANSI C63.10:2013
KDB558074 D01 DTS Meas Guidance v05r02
KDB447498 D01 General RF Exposure Guidance v06

1.2 Decision Rule of conformity

The decision rule of conformity of this test report is following the requirements of the requested standard in the quotation, and agreed among testing laboratory and manufacturer (applicant) to exclude the consideration of Measurement Uncertainty, unless it is required by the specific standard.

2. Test Sites

2.1 Test Laboratory

TUV Rheinland Taiwan Ltd.
Taipei Testing Laboratories

11F. No.758, Sec. 4, Bade Rd., Songshan Dist.
Taipei City 105
Taiwan (R.O.C.)

2.2 Test Facility

TUV Rheinland Taiwan Ltd.

11F. No.758, Sec. 4, Bade Rd., Songshan Dist.
Taipei City 105
Taiwan (R.O.C.)

FCC RegistrationNo.: 180491
IC Canada Registration No.: 9465A
TAF Accredited NCC Test Lab. No.:3567
TAF ISO17025 Certification effective period: 6th-May-2019 to 05th-May-2022



Testing Laboratory
3567

2.3 List of Test and Measurement Instruments

Table 2: List of Test and Measurement Equipment

Kind of Equipment	Manu-facturer	Type	S/N	Last Calibration	Next Calibration
Test Software	Farad	EZ_EMC	Ver. TUV3A1	N/A	N/A
EMI Test Receiver	R&S	ESR 7	101062	2018/10/01	2019/10/01
Spectrum Analyzer	R&S	FSV 40	101514	2019/02/07	2020/02/07
EXA Signal Analyzer	KEYSIGHT	N9010A	MY52221334	2019/02/15	2020/02/15
Preamplifier (30MHz -1GHz)	HP	8447F	2805A03335	2018/08/22	2019/08/22
Pre-Amplifier (1GHz~18GHz)	EM Electronics	EM01G18G	060558	2018/11/30	2019/11/30
Bilog Antenna	TESEQ	CBL 6111D	29802	2018/08/22	2019/08/22
Horn Antenna	ETS-Lindgren	3117	00218931	2018/12/27	2019/12/27
Horn Antenna (18GHz~40GHz)	COM-POWER	AH-840	101029	2018/12/22	2019/12/22
Loop Antenna	Schwarzbeck	FMZB 1513	1513-076	2018/06/21	2019/07/31
EMI Test Receiver	Rohde & Schwarz	ESCI 7	100797	2019/01/16	2020/01/16
Two-Line V-Network	Rohde & Schwarz	ENV216	101262	2018/07/10	2019/07/31

2.4 Traceability

All measurement equipment calibrations are traceable to NML(Taiwan)/NIST(USA) or where calibration is performed outside Taiwan, to equivalent nationally recognized standards organizations.

2.5 Calibration

Equipment requiring calibration is calibrated periodically in a suitably accredited Calibration Lab. Additionally all equipment is verified for proper performance on a regular schedule using in house standards or comparisons.

2.6 Measurement Uncertainty

The estimated combined standard uncertainty for radiated emissions and conducted emissions measurements .

Table 3: Emission Measurement Uncertainty

Parameter	Uncertainty
Radio Frequency	$\pm 1 \times 10^{-7}$
RF power, conducted	± 1.5 dB
RF power density, conducted	± 3 dB
spurious emissions, conducted	± 3 dB
all emissions, radiated	± 6 dB
Temperature	± 1 °C
Humidity	± 5 %

3. General Product Information

3.1 Product Function and Intended Use

The EUT is a Radio Switch. It contains a 2.4GHz compatible module enabling the user to communicate data through a Wireless interface.

For details refer to the User Guide, Data Sheet and Circuit Diagram.

3.2 System Details and Ratings

Table 4: Basic Information of EUT

Item	EUT information
Kind of Equipment/Test Item	Radio Switch
Type Designation	21P5020, 23P5020
FCC ID	W95-23P502L00

Table 5: Technical Specification of EUT

Technical Specification	Value
Operating Frequencies	2404~2452MHz
Channel number	3
Operation Voltage	3Vdc
Modulation	GFSK
Antenna gain	3.84dBi

3.3 Independent Operation Modes

Basic operation modes are:

- A. Transmitting
 - 1. Low channel
 - 2. Middle channel
 - 3. High channel
- B. Receiving
- C. Standby
- D. Off

3.4 Noise Generating and Noise Suppressing Parts

Refer to the Circuit Diagram.

3.5 Submitted Documents

- Circuit Diagram
- Blocking Diagram
- Rating Label
- Technical Description

4. Test Set-up and Operation Modes

4.1 Principle of Configuration Selection

The equipment under test (EUT) was configured to measure its maximum power level. The test modes were adapted accordingly in reference to the instructions for use.

4.2 Test Operation and Test Software

Setup for testing: The module is mounted on an Evaluation Board provided by the manufacturer. The EVB is provided with an USB-UART interface which makes it possible to control the module through the test software installed on a notebook computer.

This software was running on the laptop computer connected to the EUT. It was used to enable the operation modes listed in section 3.3 as appropriate.

The samples were used as follows:
Conducted sample: A000951751-007
Radiation sample: A000951751-008

Full test was applied on all test modes, but only worst case was shown

2.4GHz mode:

Channel Low (2404MHz), Channel Mid (2410MHz) and Channel High (2452MHz) were chosen for full testing.

4.3 Special Accessories and Auxiliary Equipment

The product has been tested together with the following additional accessories:

Description	Manufacturer	Model No.	Serial No.
Notebook(EMC-06)	Lenovo	TP00048A	PB-0F8B2
Test tool	arendi	ArendiApprovalTest	1.4.0

4.4 Countermeasures to achieve EMC Compliance

The test sample which has been tested contained the noise suppression parts as described in the Constructional Data Form or the Technical Construction File. No additional measures were employed to achieve compliance.

4.5 Test Setup Diagram

Diagram of Measurement Configuration for Radiation Test

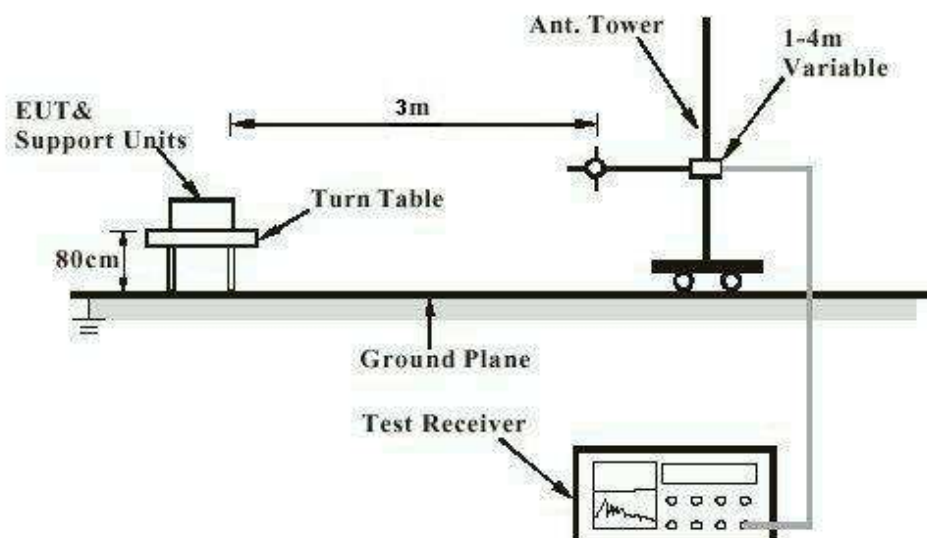

Note: Measurements above 1 GHz are done with a table height of 1.5m

Diagram of Measurement Equipment Configuration for Mains Conduction Measurement (if applicable)

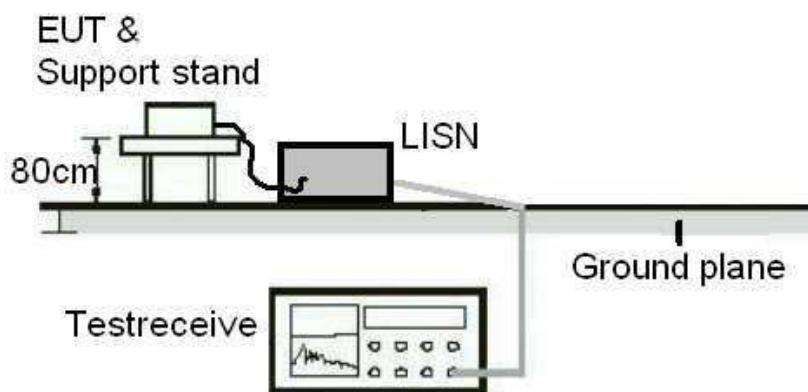
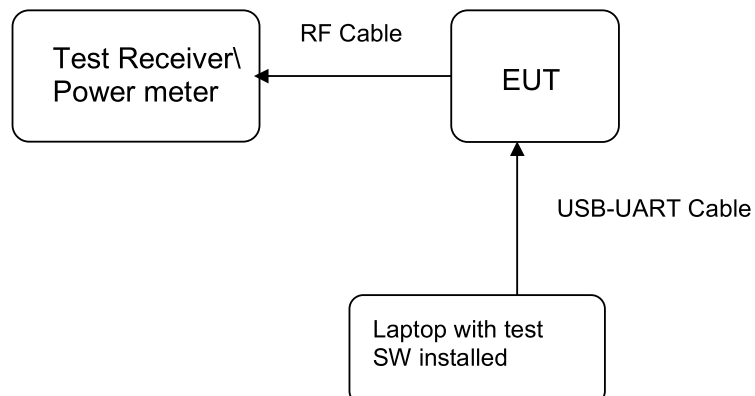

Diagram of Measurement Equipment Configuration for Conducted Transmitter Measurement



5. Test Results

5.1 Transmitter Requirement & Test Suites

5.1.1 Antenna Requirement

RESULT: **Passed**

Test standard : FCC Part 15.247(b)(4), Part 15.203

Requirement : use of approved antennas only with directional gains that do not exceed 6 dBi

According to the manufacturer declaration, the EUT has an antenna with Max directional gain of 3.84dBi. The antenna is a printed PCB trace with no possibility of replacement with a non-approved antenna by the end-user. Therefore, the EUT is considered to comply with this provision.

Refer to EUT photo for details.

5.1.2 Maximum conducted Peak output power

RESULT:
Passed

Test standard : FCC Part 15.247(b)(3)
 Basic standard : ANSI C63.10:2013, KDB558074
 Limit : 1 Watt
 Kind of test site : Shielded room

Test setup

Test Channel : Low/ Middle/ High
 Operation Mode : A

 Ambient temperature : 20-24 °C
 Relative humidity : 50-65 %
 Atmospheric pressure : 100-103 kPa

Table 6: Test result of Maximum conducted Peak output power

Channel	Channel Frequency (MHz)	Output Power		Limit
		(dBm)	(W)	(W)
Low Channel	2404	-3.76	0.00042	1
Middle Channel	2410	-3.59	0.00044	1
High Channel	2452	-2.43	0.00057	1

Pmax: -2.43dBm, 0.57mW

5.1.3 6dB Bandwidth

RESULT:
Passed

Test standard : FCC Part 15.247(a)(2)
 Basic standard : ANSI C63.10:2013, KDB558074
 Kind of test site : Shielded room

Test setup

Test Channel : Low/ Middle/ High
 Operation Mode : A

Ambient temperature : 20-24°C
 Relative humidity : 50-65%
 Atmospheric pressure : 100-103 kPa

Table 7: Test result of 6dB Bandwidth

Channel	Channel Frequency (MHz)	6dB Bandwidth (kHz)	Limit (kHz)	Result
Low Channel	2404	696.1	>500	Pass
Mid Channel	2410	702.3	>500	Pass
High Channel	2452	711.2	>500	Pass

Test Plot of 6dB Bandwidth

Low Channel



Middle Channel



High Channel

5.1.4 Power Density

RESULT:
Passed

Test standard : FCC Part 15.247(e)
 Basic standard : ANSI C63.10:2013, KDB558074
 Kind of test site : Shielded room

Test setup

Test Channel : Low/ Middle/ High
 Operation Mode : A
 Ambient temperature : 20-24°C
 Relative humidity : 50-65%
 Atmospheric pressure : 100-103 kPa

Table 8: Test result of Power Density

Channel	Channel Frequency (MHz)	Power Density	Limit
		(dBm)	(dBm)
Low Channel	2404	-21.70	8
Middle Channel	2410	-21.37	8
High Channel	2452	-20.01	8

Test Plot of Power Density

Low Channel

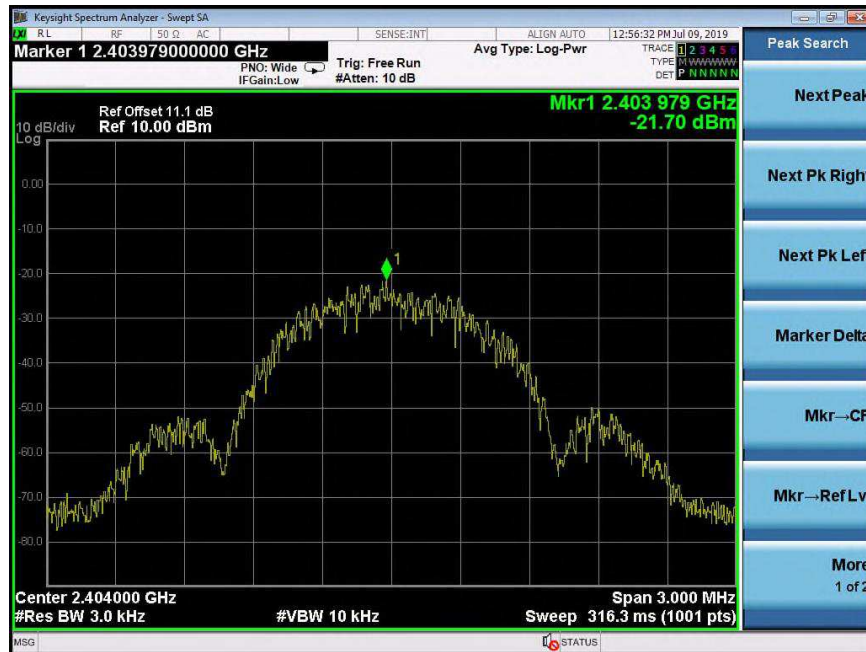

Middle Channel

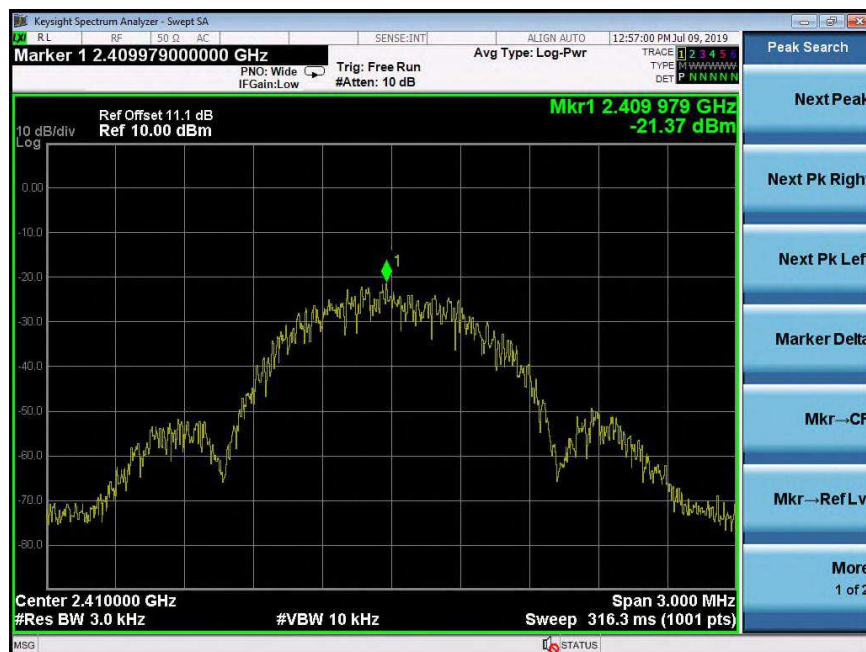

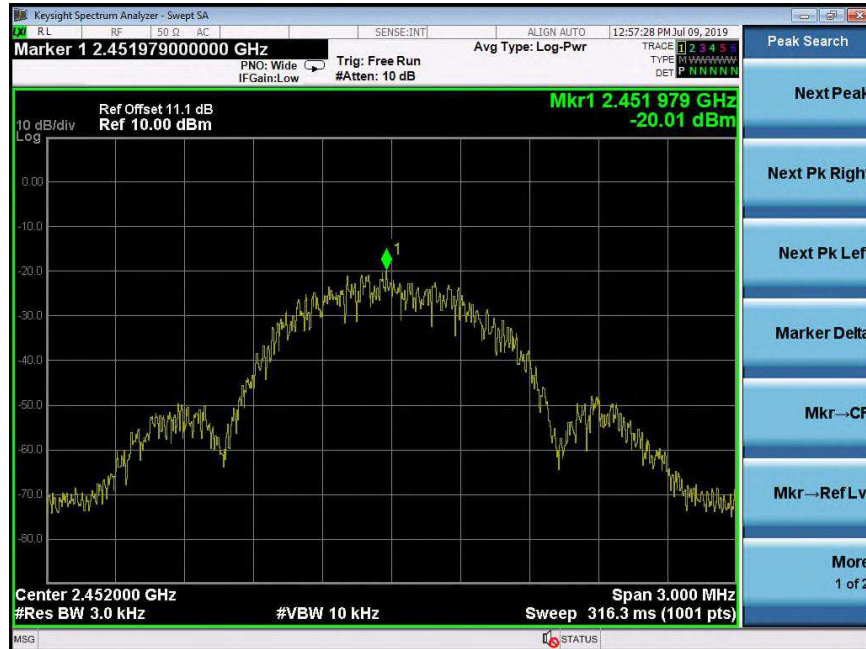
High Channel

5.1.5 Conducted spurious emissions and Frequency Band Edge measured in 100kHz Bandwidth

RESULT: **Passed**

Test standard	:	FCC part 15.247(d)
Basic standard	:	ANSI C63.10:2013, KDB558074
Limit	:	20dB (below that in the 100kHz bandwidth within the band that contains the highest level of the desired power)
Kind of test site	:	Shielded room

Test setup

Test Channel	:	Low/ Mid/ High for spurious, Low/ High for Band Edge
Operation mode	:	A
Ambient temperature	:	20-24°C
Relative humidity	:	50-65%
Atmospheric pressure	:	100-103 kPa

All emissions are more than 20dB below fundamental, details refer to following test plot, and compliance is achieved as well.

Due to the small size of the product and that there are no inductive components of significant size, 9kHz to 30MHz frequency range is not tested based on technical judgment.

Test Plot 100kHz RBW of Band Edge

Low Channel

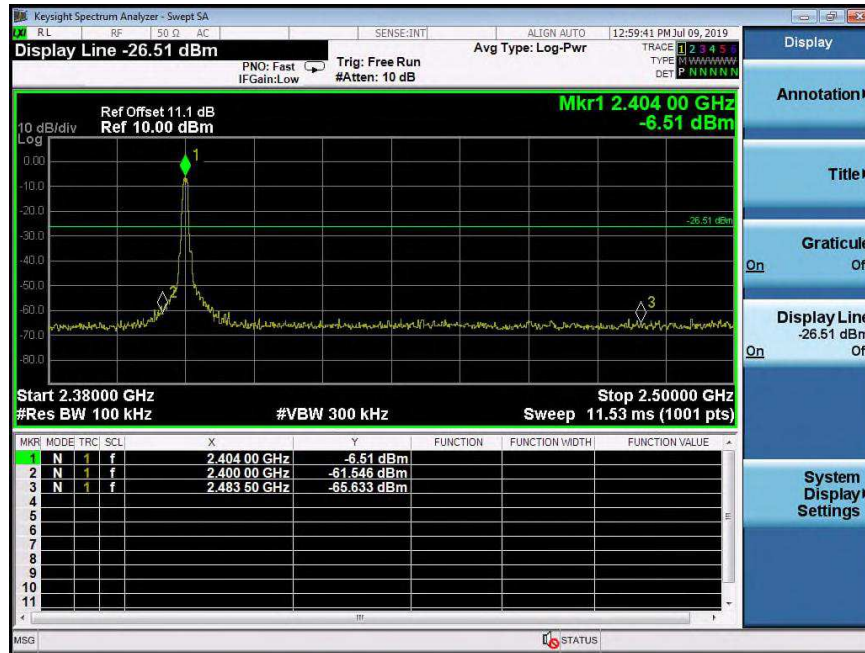

High Channel

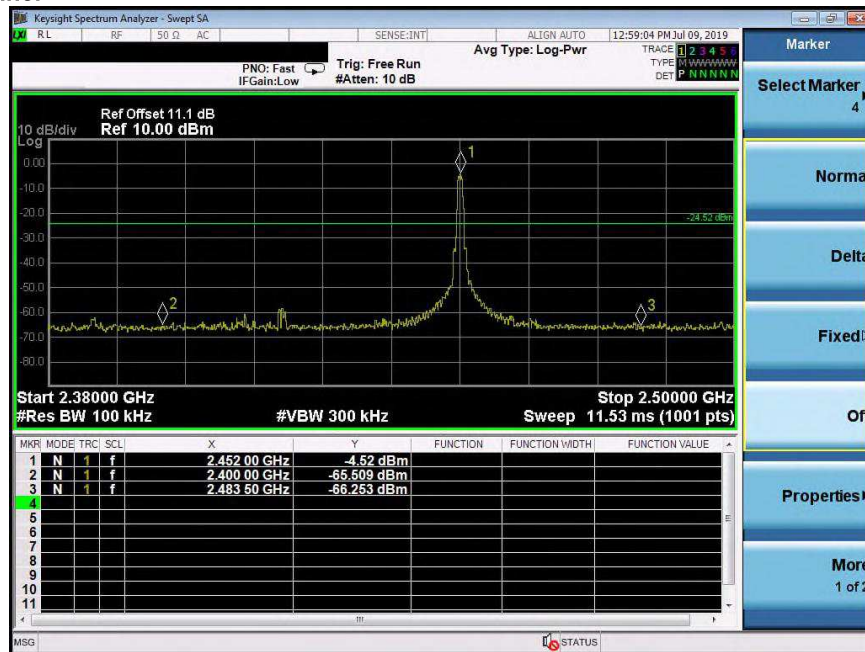

5.1.6 Spurious Emission

RESULT:**Passed**

Test standard	:	FCC part 15.247(d), FCC 15.205, FCC 15.209,
Basic standard	:	ANSI C63.10: 2013
Limits	:	Radiated emissions which fall in the restricted bands, as defined in FCC 15.205(a), must comply with the radiated emission limits specified in FCC 15.209(a). Emission radiated outside the specified frequency bands must comply with the radiated emission limits specified in FCC 15.209(a).
Kind of test site	:	3m Semi-Anechoic Chamber

Test setup

Test Channel	:	Low/ Middle/ High
Operation mode	:	A, B

For details refer to Appendix D.

The Radiated Emissions testing was performed in the X, Y and Z axis orientation. The worst-case Axis orientation is recorded in this test report.

Factor (dB/m)=Antenna Factor(dB/m)+Cable loss (dB)
Level(dBuV/m)=Reading(dBuV)+ Factor(dB/m)

6. Safety Human exposure

6.1 Radio Frequency Exposure Compliance

6.1.1 Electromagnetic Fields

RESULT:**Passed**

Test standard : FCC KDB Publication 447498 D01 v06
47CFR 1.1310
47CFR 2.1091

FCC:

Therefore the maximum output power of the transmitter is $0.57\text{mW} < 10\text{mW}$ (Distance: 5 mm), hence the EUT is excluded from SAR evaluation according to FCC KDB publication 447498 D01: Mobile Portable RF Exposure.

---End---

7. Photographs of the Test Set-Up

Photograph 1: Set-up for Spurious Emissions (Front View 1)



Photograph 2: Set-up for Spurious Emissions (Front View 2)



Photograph 3: Set-up for Spurious Emissions (Back View 1)



Photograph 4: Set-up for Spurious Emissions (Back View 2)

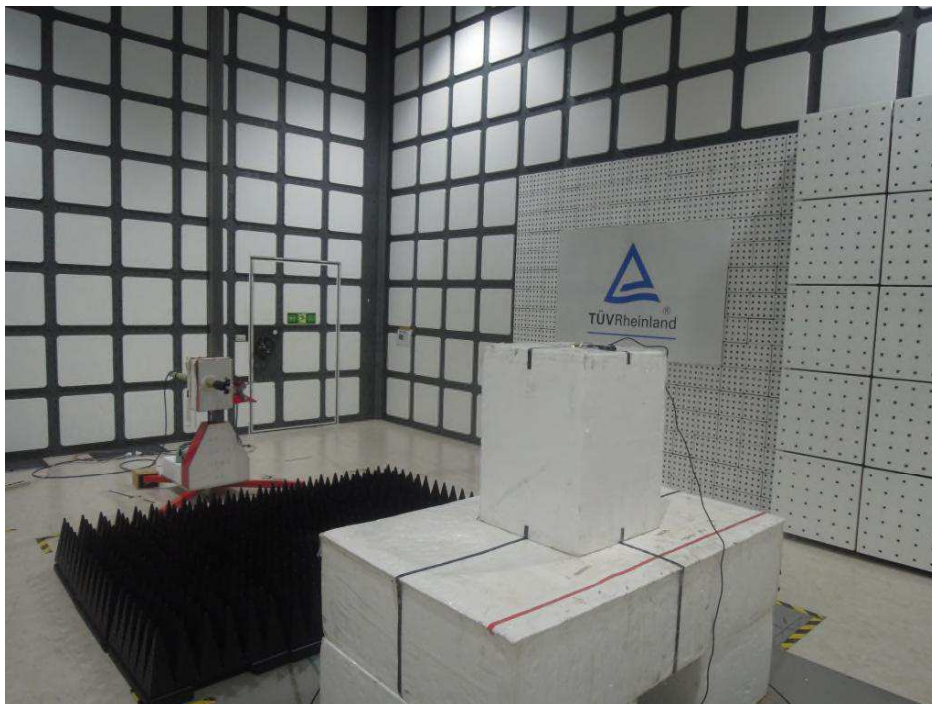

Photograph 5: Set-up for Spurious Emissions (Back View 3)



Photograph 6: Set-up for Spurious Emissions (Back View 4)

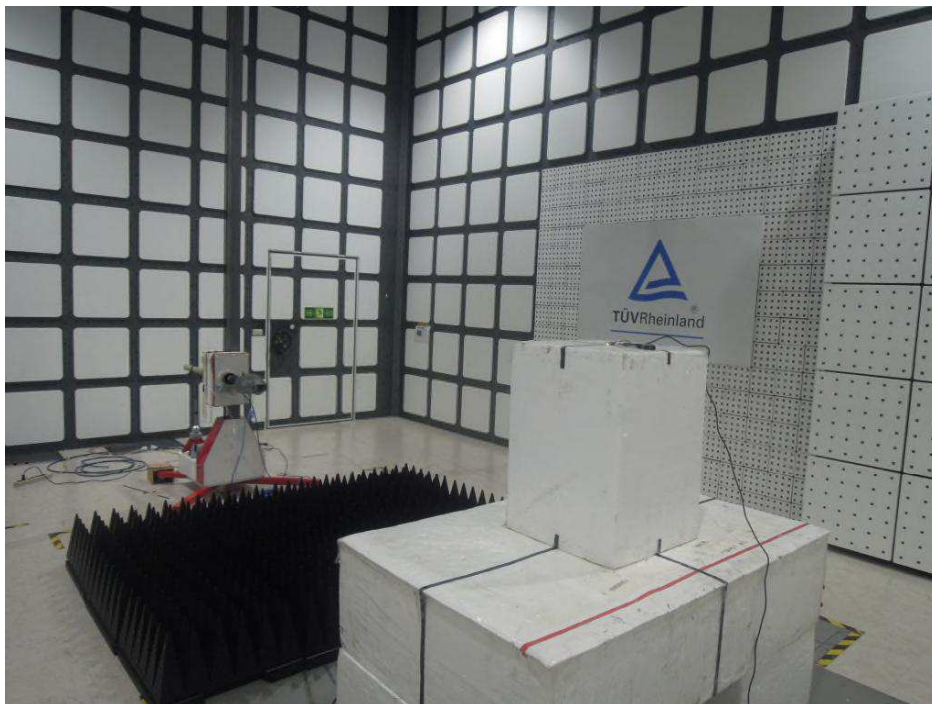

Photograph 7: Set-up for Conducted testing



Photograph 8: Set-up for Conducted testing

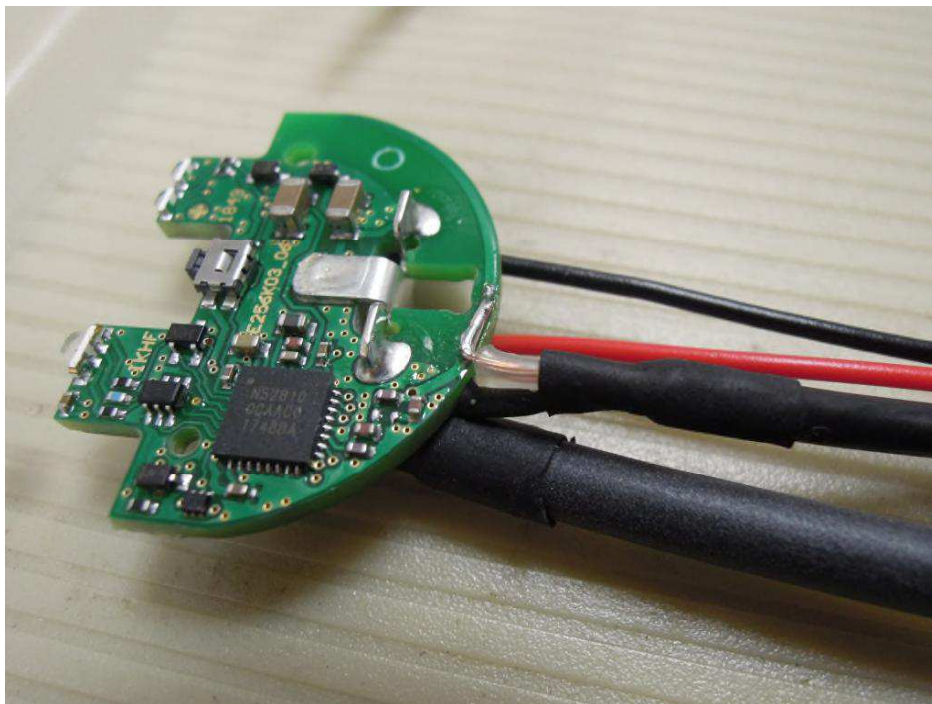

8. List of Tables

Table 1: Applied Standard and Test Levels	5
Table 2: List of Test and Measurement Equipment	7
Table 3: Emission Measurement Uncertainty.....	8
Table 4: Basic Information of EUT	9
Table 5: Technical Specification of EUT	9
Table 6: Test result of Maximum conducted Peak output power	15
Table 7: Test result of 6dB Bandwidth	16
Table 8: Test result of Power Density	19

9. List of Photographs

Photograph 1: Set-up for Spurious Emissions (Front View 1).....	28
Photograph 2: Set-up for Spurious Emissions (Front View 2).....	28
Photograph 3: Set-up for Spurious Emissions (Back View 1).....	29
Photograph 4: Set-up for Spurious Emissions (Back View 2).....	29
Photograph 5: Set-up for Spurious Emissions (Back View 3).....	30
Photograph 6: Set-up for Spurious Emissions (Back View 4).....	30
Photograph 7: Set-up for Conducted testing	31
Photograph 8: Set-up for Conducted testing	31