

SERVO-DRIVE

by Blum

BLUMOTION

by Blum

EN



SERVO-DRIVE

Instruction leaflet

www.blum.com

 **blum**[®]

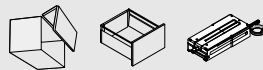

Table of contents

About these instructions	2
Warning signs and danger symbols	3
Safety	3
Disposal	12
Orientation diagram: SERVO-DRIVE for AVENTOS/SERVO-DRIVE uno for AVENTOS	14
Orientation diagram: SERVO-DRIVE for LEGRABOX/TANDEMBOX/MOVENTO/TANDEM	14
Orientation diagram: SERVO-DRIVE flex for refrigerators, freezers and dishwashers.....	15
How to operate: SERVO-DRIVE for AVENTOS/SERVO-DRIVE uno for AVENTOS.....	16
How to operate: SERVO-DRIVE for LEGRABOX/TANDEMBOX/MOVENTO/TANDEM	20
How to operate: SERVO-DRIVE flex for refrigerators, freezers and dishwashers	22
Troubleshooting: SERVO-DRIVE for AVENTOS/SERVO-DRIVE uno for AVENTOS	24
Troubleshooting: SERVO-DRIVE for LEGRABOX/TANDEMBOX/MOVENTO/TANDEM	25
Troubleshooting: SERVO-DRIVE flex	26
Technical data	28
Simplified EU/UK Declaration of Conformity – Julius Blum GmbH	31
Spare parts form	33

About these instructions

Thank you for your purchase. SERVO-DRIVE, the electrical motion support system by Julius Blum GmbH, is a high-quality product that simplifies everyday kitchen tasks.

To safely enjoy the comfort of SERVO-DRIVE, please note the following:

- Carefully read the instruction leaflet before use.
- Please retain the instruction leaflet for the service life of SERVO-DRIVE.
- Please pass on this instruction leaflet to each subsequent owner or user of SERVO-DRIVE.
- Instructions are also available on our website. Please search on www.blum.com for "SERVO-DRIVE instruction leaflet" and download it as a PDF file.

Validity and target group

This instruction leaflet is intended for all users of SERVO-DRIVE. Assembly, adjustment, initial operation, maintenance and removal may only be carried out by qualified personnel according to the separate installation instructions.

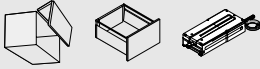

Warning signs and danger symbols

WARNING

WARNING indicates a danger that could lead to death or serious injury if not heeded.

NOTE

NOTE indicates information that should be followed.



To identify an appliance intended only for indoor use.



To identify terminals that must not be connected to the mains voltage.

Intended use

SERVO-DRIVE supports the opening and closing of lift systems, the opening of drawers and/or refrigerators and freezers or dishwashers, and may only be used under the following conditions:

- In dry, enclosed rooms.
- In combination with AVENTOS lift systems and/or pull-out systems from Julius Blum GmbH within permitted technical specifications.
- In combination with a Blum transformer.
- The furniture must be firmly secured to the wall so that it cannot topple over.

Technical data specifications can be found in the Blum sales documentation. For more information, please see your distributor. Julius Blum GmbH is not liable for any other use.



Safety

Principle

SERVO-DRIVE complies with current safety standards. Nevertheless, there will still be certain residual risks if the information contained in this instruction leaflet is not observed. Please be aware that Julius Blum GmbH is not responsible for incidental or consequential damages that may arise due to non-compliance with this instruction leaflet.

Safety information

- The mains plug and the Blum transformer must be easily accessible.
- Neither the Blum transformer nor any cabling should come into contact with moving parts.
- This appliance can be used by children aged from 8 years and above and persons with reduced physical, sensory or mental capabilities or lack of experience and knowledge if they have been given supervision or instruction concerning use of the appliance in a safe way and understand the hazards involved. Children must not play with the appliance. Cleaning and user maintenance must not be carried out by children without supervision.
- Reaching into the area around the lift system lever during the opening and closing motion can cause injury.
- The overall length of the cable for the 12-Watt Blum transformer (Z10NE0300) must not exceed 2 m.
- The 24-Watt Blum transformer (Z10NE030) must be connected to an outlet with an earth connection.
- The 24-Watt Blum transformer (Z10NE030) incorporates an earth connection for functional purposes only.



Structural changes and spare parts

Structural changes and replacement parts not approved by the manufacturer affect the safety and functionality of SERVO-DRIVE and are, therefore, not allowed.

- Only use original spare parts from Julius Blum GmbH.
- Blum components are the only devices that should be connected to the Blum transformer.
- Only qualified persons may install or replace Blum components, modify the position of the Blum transformer or modify the cabling.
- Please make sure that the Blum distance bumper is attached to the front.

NOTE

To ensure that lift systems, drawers, refrigerators or freezers and dishwashers cannot be activated unintentionally, we recommend connecting the Blum transformer to a switched outlet. For more information, please consult an electronics retailer.

Children

⚠ WARNING

Opening and closing lift systems may pose a risk of injury to children.

Persons, especially children, who are sitting or standing on work surfaces may be pushed from work surfaces or injured when opening and closing a lift system.

May pose a choking hazard to children when playing with the SERVO-DRIVE switch.

Children could choke on the SERVO-DRIVE switch battery.

- Make sure that children do not open the SERVO-DRIVE switch as they could choke on parts or the battery from the SERVO-DRIVE switch if they swallow them.

Opening drawers may pose a risk of injury to children!

- Children should be properly supervised when in the room so that they do not play with the lift system.
- To ensure that SERVO-DRIVE is not triggered unintentionally, the switched outlet should be turned off.

Cabinet care and cleaning

⚠ WARNING

Danger of death from electric shock!

There is a danger of electric shock if fluids penetrate the Blum transformer.

- Before cleaning the front, turn off the switched outlet to which the Blum transformer is connected.
- Before cleaning the drive unit and/or Blum transformer, disconnect the Blum transformer from the power.
- Make sure that no water or aggressive cleaning materials come into contact with the drive unit, the Blum transformer or the SERVO-DRIVE switch while cleaning the cabinet – use a moist cloth.
- Never open a Blum transformer, drive unit or SERVO-DRIVE switch.
- Any cabling damage should be immediately repaired by a qualified specialist.
- Do not cover the Blum transformer with cloths or other items – danger of overheating.
- Examine the appliance frequently for signs of wear or damage. If there are such signs or if the appliance has been misused or does not work, contact the supplier for further information

⚠ WARNING

Danger of injury if the lever springs upward!

There is a danger of injury from the lever springing upwards during improper removal of the front including fittings.



- Never remove the front for cleaning.
- Front removal may only be carried out by qualified personnel according to the separate installation instructions.

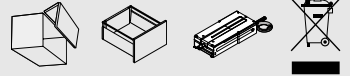

Disposing of electrical and electronic appliances

Electrical and electronic appliances must not be disposed of with household waste at the end of their service life. Ask your local authority for information on how to proceed. Blum electrical and electronic appliances meet the requirements of the WEEE Directive

2012/19/EU. Electrical and electronic appliances are collected separately, which enables old appliances to be reused or recycled, and their materials to be reused. This is intended to prevent any hazardous materials that may be contained in the appliances from damaging the environment and health during disposal. In most cases, the entire appliance does not need to be disposed of according to the WEEE guidelines, but only the part that is equipped with electrical components. Please refer to the disassembly instructions for information on this. There are free collection points for returning electrical and electronic appliances in your area. You will find further information on this under the following link:

www.blum.com/recycling

Disposing of batteries

Batteries must not be disposed of with household waste at the end of their service life. Ask your local authority for information on how to proceed. Batteries used at Blum meet the requirements of the Battery Directive 2006/66/EC. Batteries are collected separately, which enables the batteries or their materials to be recycled. This is intended to prevent any hazardous materials that may be contained in the appliances from damaging the environment and health during disposal. Please refer to the disassembly instructions for information on removing batteries. There are free collection points for returning batteries in your area. Please avoid shorting the contact surfaces when disposing of batteries.



限用物質含有情況標示聲明書 Declaration of the Presence Condition of Restricted Substances			限用物質及其化學符號 Restricted substances and its chemical symbols					
設備名稱, Equipment name:	型號(型式), Type designation (Type):	單元, Unit:	鉛 Lead (Pb)	汞 Mercury (Hg)	鎘 Cadmium (Cd)	六價鉻 Hexavalent chromium (Cr ⁺⁶)	多溴聯苯 Polybrominated biphenyls (PBB)	多溴二苯醚 Polybrominated diphenyl ethers (PBDE)
電源適配器	Z10NA300	電子元件 + 印刷電路板 Electronic components+PCB	○	○	○	○	○	○
		外殼 Housing	○	○	○	○	○	○
		輸出線材 Output cable	○	○	○	○	○	○
		交流電輸入端子 AC Input Pin	—	○	○	○	○	○
電源適配器	Z10NE030	電子元件 + 印刷電路板 Electronic components+PCB	○	○	○	○	○	○
		外殼 Housing	○	○	○	○	○	○
		輸出線材 Output cable	○	○	○	○	○	○
驅動單元	21xA00y "x" ∈ {F,L,S,K} "y" ∈ {0,1}	電子元件 + 印刷電路板 Electronic components+PCB	○	○	○	○	○	○
		馬達 Motor	○	○	○	○	○	○
		變速器 Gearbox	○	○	○	○	○	○
驅動單元	23KA00y "y" ∈ {0,1}	電子元件 + 印刷電路板 Electronic components+PCB	○	○	○	○	○	○
		馬達 Motor	○	○	○	○	○	○
		變速器 Gearbox	○	○	○	○	○	○
驅動單元	Z10A3000	電子元件 + 印刷電路板 Electronic components+PCB	○	○	○	○	○	○
		馬達 Motor	○	○	○	○	○	○
		變速器 Gearbox	○	○	○	○	○	○
驅動單元	Z10C5000	電子元件 + 印刷電路板 Electronic components+PCB	○	○	○	○	○	○
		馬達 Motor	○	○	○	○	○	○
		變速器 Gearbox	○	○	○	○	○	○
		電纜線材 Cable	○	○	○	○	○	○
備考 1, Note 1:	"超出0.1 wt %"及"超出0.01 wt %"係指限用物質之百分比含量超出百分比含量基準值。 "Exceeding 0.1 wt. %" and "exceeding 0.01 wt %" indicate that the percentage content of the restricted substance is exceeding the reference percentage value of presence condition.							
備考 2, Note 2:	"○" 係指該項限用物質之百分比含量未超出百分比含量基準值。 "○" indicates that the percentage content of the restricted substance does not exceed the percentage of reference value of presence.							
備考 3, Note 3:	"—" 係指該項限用物質為排除項目。 "—" indicates that the restricted substance corresponds to the exemption.							

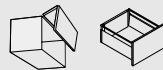

SERVO-DRIVE for AVENTOS/SERVO-DRIVE uno for AVENTOS

SERVO-DRIVE for AVENTOS supports the opening and closing of lift systems in furniture.

Orientation diagram

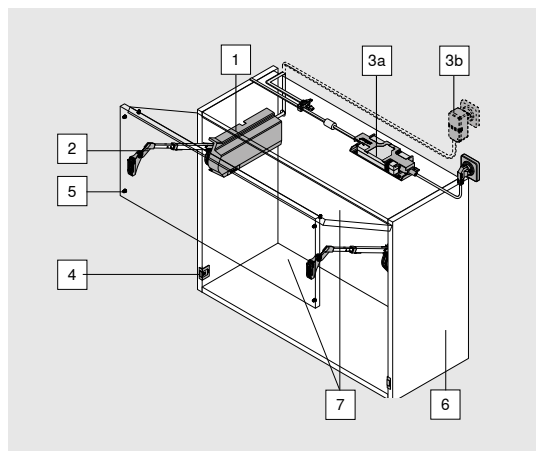

- 1 Lift mechanism, drive unit and cover cap
- 2 Lever
- 3a Blum transformer, 24 Watts
- 3b Blum plug-in transformer, 12 Watts
- 4 SERVO-DRIVE switch
- 5 Blum distance bumper
- 6 Cabinet
- 7 Front/Lift system

SERVO-DRIVE for LEGRABOX/TANDEMBOX/MOVENTO/TANDEM

SERVO-DRIVE supports the opening of drawers.

Orientation diagram

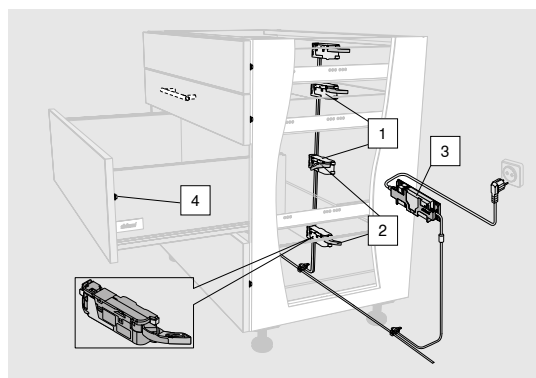

- 1 Drive unit
- 2 Eject lever
- 3 Blum transformer
- 4 Blum distance bumper



SERVO-DRIVE flex for refrigerators and freezers

SERVO-DRIVE flex allows handle-less refrigerators and freezers to be opened electromechanically by pressing the front.

Orientation diagram

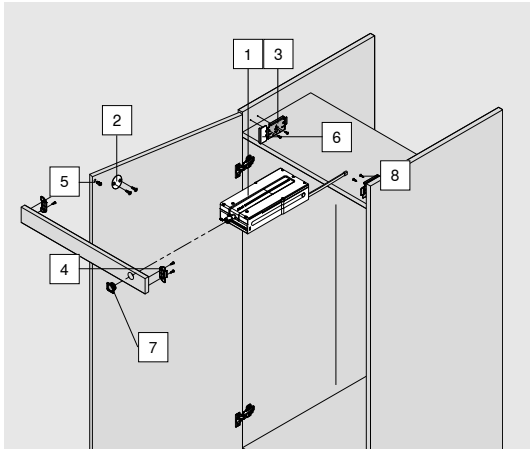

- 1 Drive unit
- 2 Catch plate
- 3 Mounting plate
- 4 Front fixing
- 5 Blum distance bumper
- 6 Assembly jig
- 7 Front cover
- 8 Chipboard screws

SERVO-DRIVE flex for dishwashers

SERVO-DRIVE flex allows handle-less dishwashers to be opened electromechanically by pressing the front.

Orientation diagram

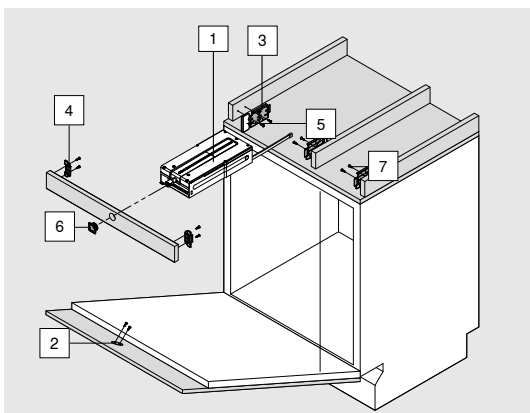

- 1 Drive unit
- 2 Catch plate
- 3 Mounting plate
- 4 Front fixing
- 5 Assembly jig
- 6 Front cover
- 7 Chipboard screws

SERVO-DRIVE for AVENTOS/SERVO-DRIVE uno for AVENTOS

Electrical motion support system

The SERVO-DRIVE switch triggers the automatic opening and closing action of SERVO-DRIVE for AVENTOS.

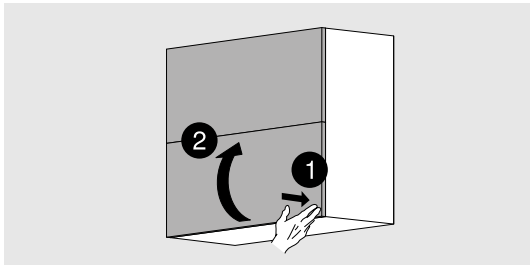

Press on the front

- The lift system opens automatically

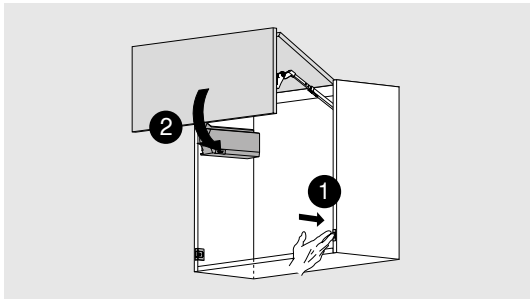

Press on the SERVO-DRIVE switch

- The lift system closes automatically



Manual operation

The lift system can be opened or closed manually at any time without damaging SERVO-DRIVE for AVENTOS.

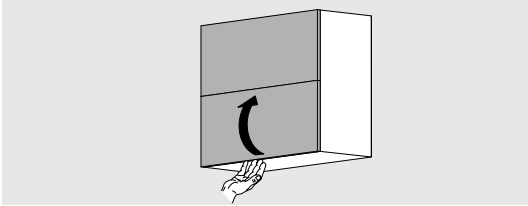

- Manual opening of the lift system by moving it upwards

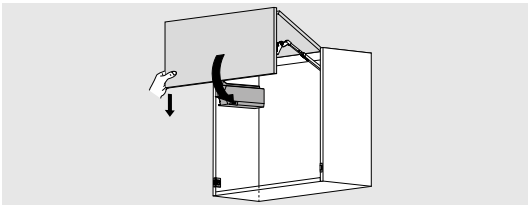

- Manual closing of the lift system by moving it downwards

Collision detection

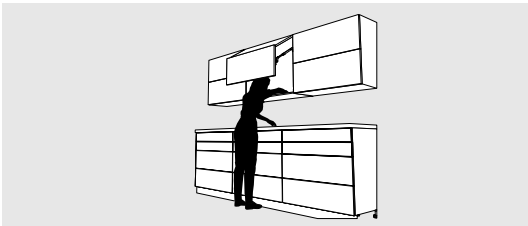

The opening and closing action is interrupted automatically via the integrated collision detection feature when the front hits a body part or other object.

Lean protection feature

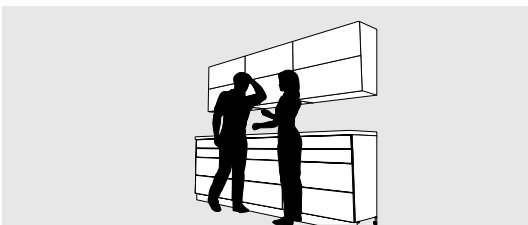

SERVO-DRIVE for AVENTOS is only triggered by a brief touch. Leaning on the lift system will not open it.



Power failure

If the power supply is interrupted during the opening or closing process, the SERVO-DRIVE for AVENTOS lift system will remain in that position. The front can be closed manually, or when power is restored; simply touch the switch to re-activate SERVO-DRIVE function.

The following parameters must be observed to ensure the error-free functioning of SERVO-DRIVE for AVENTOS:

- Blum distance bumpers must be attached to the front to maintain the required distance between the lift system and the cabinet.
- No items should be placed between the front and the cabinet.

NOTE

- Improper use may cause SERVO-DRIVE for AVENTOS to wear prematurely!
 - Do not press or pull with force against the movement direction when opening or closing the lift system.
 - Never remove the front. Front removal may only be carried out by qualified personnel. See also the safety section at the first pages of this leaflet.
-

SERVO-DRIVE switch

The SERVO-DRIVE switch is battery-operated (CR2032).

Only use batteries from reputable manufacturers.

A

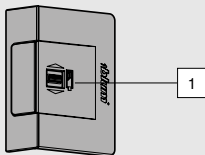

1 Battery display (LED)

B

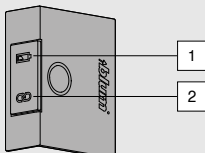

1 Battery display (LED)

2 Connect (LED)



Replacing the battery

When the battery power begins to weaken, the battery display (LED) will begin to flash red.

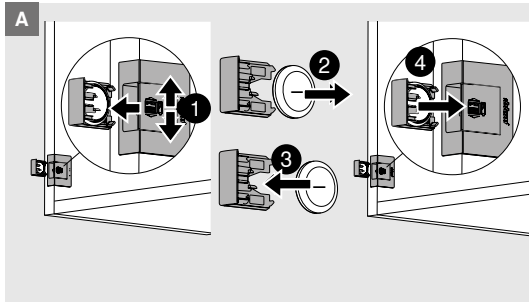

- 1 Open the SERVO-DRIVE switch and remove the battery holder
- 2 Remove the battery
- 3 Insert new battery (type CR2032), observing the correct pole connections
- 4 Close battery holder

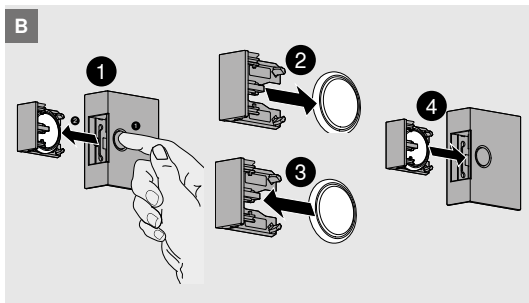

- 1 Open the SERVO-DRIVE switch and remove the battery holder
- 2 Remove the battery
- 3 Insert new battery (type CR2032), observing the correct pole connections
- 4 Close battery holder

If the battery is inserted incorrectly, the SERVO-DRIVE switch battery display will flash red.

NOTE

The SERVO-DRIVE switch battery must not be recharged or discarded into fire.

SERVO-DRIVE for LEGRABOX/TANDEMBOX/MOVENTO/TANDEM

Electrical motion support system

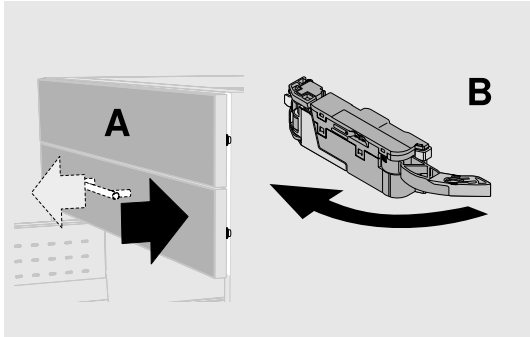

When the front and/or handle of the drawer (A) is pulled or pressed, the eject lever of the drive unit (B) swivels forward and opens the pull-out unit a short distance.

Lean protection feature

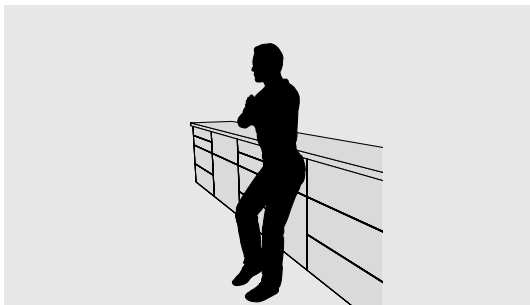

The electrical opening support function is only triggered by a brief touch or pull. Leaning on the pull-out unit, for example, will not open it.



The following parameters must be observed to ensure the error-free functioning of SERVO-DRIVE:

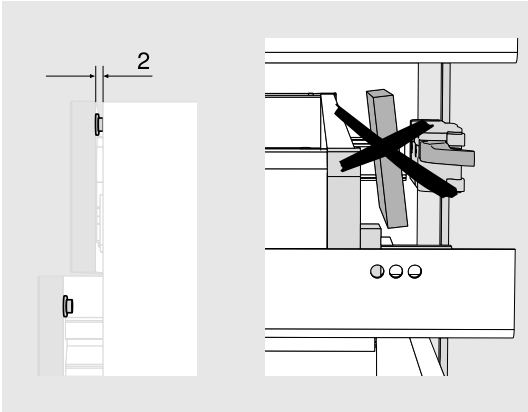

- Blum distance bumpers must be attached to the front to ensure the required triggering signal (2 mm) between the pull-out unit and the cabinet.
- No items can be clamped between the pull-out unit and the cabinet back and/or SERVO-DRIVE.

Blum transformers

Blum transformers provide power to the drive unit. Blum transformer function can be checked via the operating mode display (LED).

24W:

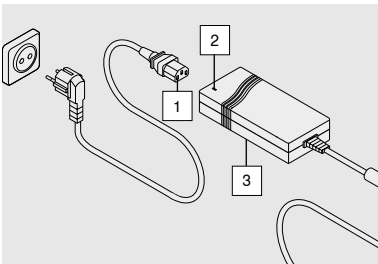

12W:

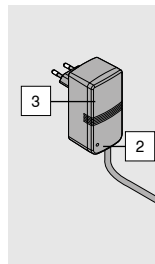

- 1 Power connection
- 2 Operating mode display
- 3 (LED) Serial tag

NOTE

- Improper use may cause SERVO-DRIVE for pull-out systems to wear prematurely!
 - Do not press or pull with force against the movement direction when opening or closing the drawer.
-



SERVO-DRIVE flex

Electrical motion support system

Pressing the handle-less front will trigger the electromechanical opening of SERVO-DRIVE flex.

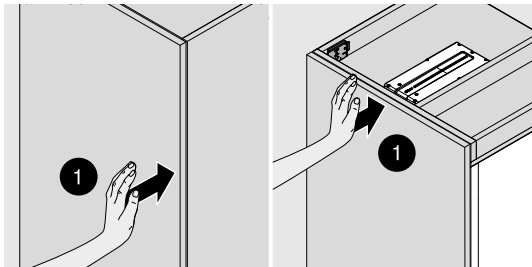

- 1) Press (do not pull) the front
 - The door (refrigerator or dishwasher) will open slightly for 2.5 sec

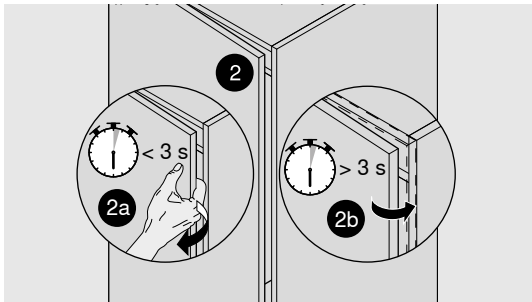

- 2) User uses opening to grip door
 - Continues opening process

- 2b) User does not touch door
 - Door closes again

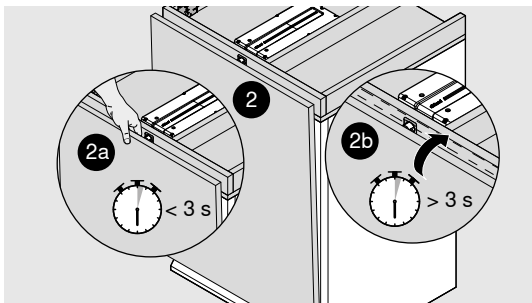



Problems	Possible cause	Remedy
Battery display on SERVO-DRIVE switch flashes red.	SERVO-DRIVE switch battery is losing power.	➤ Replace the battery.
Battery display lights up red	Battery has been inserted incorrectly.	➤ Insert the battery correctly.
SERVO-DRIVE for AVENTOS does not open or close completely.	The front is not balanced or does not lie flat on the cabinet evenly.	➤ Contact your distributor's customer service to readjust the front.
SERVO-DRIVE for AVENTOS does not work on one particular lift system when pressing on the front or using the SERVO-DRIVE switch.	SERVO-DRIVE switch battery has run out of power.	➤ Replace the battery.
	Battery was inserted incorrectly.	➤ Insert the battery correctly.
	SERVO-DRIVE switch is defective.	➤ Contact your distributor's customer service to replace the SERVO-DRIVE switch.
	Drive unit is defective.	➤ Contact your distributor's customer service to replace the drive unit.
	Cabling is defective.	➤ Contact your dealer's customer service to correct the problem.
SERVO-DRIVE for AVENTOS does not close completely.	An object is between the lift system and cabinet or jammed between the lever and front.	➤ Remove the obstruction.
	An object juts out over the front edge of the cabinet.	➤ Remove the obstruction.
Lift mechanism adjustment display lights up.	The front is not balanced.	
[OK] button of drive unit lights up red continuously.	Drive unit is defective.	➤ Replace drive unit.



Problems

Possible cause

Remedy

SERVO-DRIVE for LEGRABOX/TANDEMBOX/MOVENTO/TANDEM will not work on any drawers when pushing or pulling.

The Blum transformer is not connected to the power outlet.

➤ Plug in the Blum transformer to the outlet.

The power supply has been interrupted.

➤ Check the circuit breaker/fuse box.
➤ If necessary, contact an authorised electrician.

Blum transformer is defective.

➤ If necessary, have the distributor's customer service replace the Blum transformer.

SERVO-DRIVE for LEGRABOX/TANDEMBOX/MOVENTO/TANDEM will not work for an entire cabinet when pushing or pulling.

Cabling is defective.

➤ Contact your dealer's customer service to correct the problem.

SERVO-DRIVE for LEGRABOX/TANDEMBOX/MOVENTO/TANDEM will only work when drawer is pulled – not by pushing.

Object is obstructing path.

➤ Remove the obstruction.

Blum distance bumper was removed or is defective.

➤ Contact your dealer's customer service to replace the Blum distance bumper.

SERVO-DRIVE for LEGRABOX/TANDEMBOX/MOVENTO/TANDEM does not work for an individual pull-out unit – neither pulling nor pushing.

Max. fill height of drawer has been exceeded.

➤ Open the drawer manually.
➤ Remove the items that are too high from the pull-out unit.

SERVO-DRIVE is defective.

➤ Contact your distributor's customer service to replace the drive unit.



Problems

The refrigerator door does not open

Possible cause

If the door of the device is left open for a relatively long time, for example when putting away shopping, a vacuum may be created inside the refrigerator or freezer after it has been closed. This may result in it not being possible to open the door of the device for a few seconds.

Remedy

- Wait for the pressure to neutralise (this may take up to 20 sec)

SERVO-DRIVE flex for refrigerators, freezers and dishwashers:

- Unit does not respond to activation
- Unit responds slowly to activation
- Unit does not open fully

Mounting plate has been installed too far back

- Check position using assembly template
- Ensure dimensions correspond to assembly instructions

Blum distance bumper pad not inserted or positioned incorrectly

- Install Blum distance bumper pad
- Correct positioning

Front gap too small
Front gap too large

- Adjust front gap to 2.5–3 mm (in accordance with instructions for white goods)

Trigger fails to initiate movement across entire front height

- Wireless switches are recommended

Incorrect drilling cover (blocked rod)

- Drill a new front

Refrigerator assembly stops have not been removed

- Remove in accordance with white goods instructions

The reference run has not been carried out correctly (e.g. due to manual interference during the reference run).

- Reset system, begin a new reference run



Problems	Possible cause	Remedy
Door does not close	Catch plate is not installed	➤ Install catch plate
	Catch plate is positioned incorrectly	➤ Reposition the catch plate
Dishwasher does not close completely	Dishwasher locking mechanism has become stiff (depending on model)	➤ Push front until it closes (this is NOT a product defect)



Technical data

The appliances must only be used in dry, closed rooms. All SERVO-DRIVE appliances are of protection class III and must only be supplied with safety extra-low voltage (SELV). They are only to be used with the transformers provided by Blum.

24-Watt Blum transformer Z10NE030

Input voltage:	100–240 V a.c. $\pm 10\%$ / 50–60 Hz $\pm 10\%$
Input current:	0.6 A
Output power:	24.0 W
Output voltage:	24.0 V d.c.
Output current:	1.0 A
Ambient temperature:	0 to +40°C / 5 to 80% r.H. non condensing
Protection category:	IP40
Average active efficiency:.....	86.8%
Efficiency at low load (10%):	84.0%
No-load power consumption:	<0.08 W
Maximum altitude:	2000 m (at an ambient temperature of 25°C)

12-Watt Blum transformer Z10NA300

Input voltage:	100–240 V a.c. $\pm 10\%$ / 50–60 Hz $\pm 10\%$
Input current:	0.3 A
Output power:	12.0 W
Output voltage:	24.0 V d.c.
Output current:	0.5 A
Ambient temperature:	0 to +40°C / 5 to 80% r.H. non condensing
Protection category:	IP44
Average active efficiency:.....	83.3%
Efficiency at low load (10%):	78.0%
No-load power consumption:	<0.08 W
Maximum altitude:	2000 m (at an ambient temperature of 25°C)

**SERVO-DRIVE drive unit for AVENTOS**

Supply voltage:	24.0 V d.c.
Rated current:	2.0 A
Power consumption in standby mode:	< 0.6 W (front closed)
Ambient temperature:	0 to +40°C / 5-80% r.H. non condensing
Protection category:	IP20
Operating mode:	S3 5% max. 10 motions/10 min.
Frequency band:.....	2.404 to 2.452 GHz
Maximum radio-frequency power:.....	+4 dBm / 2.5 mW
Maximum altitude:	2000 m (at an ambient temperature of 25°C)

SERVO-DRIVE drive unit for AVENTOS HK top

Supply voltage:	24.0 V d.c.
Rated current:	2.0 A
Power consumption in standby mode:	< 0.6 W (front closed)
Ambient temperature:	0 to +40°C / 5 to 80% r.H. non condensing
Protection category:	IP20
Operating mode:	S3 5% max. 10 motions/10 min.
Frequency band:.....	2.404 to 2.452 GHz
Maximum radio-frequency power:.....	.4 dBm / 2.5 mW
Maximum altitude:	2000 m (at an ambient temperature of 25°C)

SERVO-DRIVE drive unit for LEGRABOX / TANDEMBOX / MOVENTO / TANDEM

Supply voltage:	24.0 V d.c.
Rated current:	2.0 A
Power consumption in standby mode:	<0.12 W
Ambient temperature:	0 to +50°C / 5 to 80% r.H. non condensing
Protection category:	IP20
Operating mode:	S3 5% max. 10 motions/10 min.
Maximum altitude:	2000 m (at an ambient temperature of 25°C)



SERVO-DRIVE flex drive unit

Supply voltage:	24.0 V d.c.
Rated current:	2.0 A
Power consumption in standby mode (without wireless receiver):	<0.12 W
Power consumption in standby mode (with wireless receiver):	<0.21 W
Ambient temperature:	0 to +50°C / 5 to 80% r.H. non condensing
Protection category:	IP20
Operating mode:	S3 5% max. 10 motions/10 min.
Frequency band (of wireless receiver):	2.404 to 2.452 GHz
Maximum radio-frequency power: (of wireless receiver):	+4 dBm / 2.5 mW
Maximum altitude:	2000 m (at an ambient temperature of 25°C)

SERVO-DRIVE switch

Frequency band:	2.404 to 2.452 GHz
Transmission method:	Bidirectional, via a coded wire
Range:	typically 10 m (depending on material and contents)
Ambient temperature:	0 to +40°C / 5 to 80% r.H. non condensing
Protection category:	IP20
Operating mode:	S3 5% max. 10 motions/10 min.
Battery supply:	3 V Lithium button cell CR2032
Maximum radio-frequency power:	+4 dBm / 2.5 mW
Maximum altitude:	2000 m (at an ambient temperature of 25°C)



Simplified EU declaration of conformity

Julius Blum GmbH hereby declares that all electrical and electronic article types of Julius Blum GmbH conform to the Directive 2011/65/EU.

Julius Blum GmbH hereby declares that the machine types Z10A3000 and Z10C5000 conform to the Directive 2006/42/EC and Directive 2014/30/EU.

Julius Blum GmbH hereby declares that the machine types 23KA001, 23KA000, 21FA001, 21FA000, 21LA001, 21LA000, 21SA001, 21SA000, 21KA001 and 21KA000 conform to the Directive 2006/42/EC and Directive 2014/53/EU.

Julius Blum GmbH hereby declares that the radio equipment types 23.A00L83, 23P5020, 21P5020 and Z10C5007 conform to the Directive 2014/53/EU.

Julius Blum GmbH hereby declares that the electrical and electronic article types Z10ZE000 and Z10ZC000 conform to the Directive 2014/30/EU.

Julius Blum GmbH hereby declares that the Blum transformer types Z10NA300 and Z10NE030 conform to the Directive 2014/35/EC and Directive 2014/30/EU.

The complete text of the EU declaration of conformity is available at the following Internet address:

www.blum.com/compliance

SIMPLIFIED UK DECLARATION OF CONFORMITY

Hereby, Julius Blum GmbH declares that all electrical and electronic article types of Julius Blum GmbH are in compliance with UK statutory requirement 2012 No. 3032.

Hereby, Julius Blum GmbH declares that the machinery types Z10A3000 and Z10C5000 are in compliance with UK statutory requirement 2008 No. 1597 and UK statutory requirement 2016 No. 1091.

Hereby, Julius Blum GmbH declares that the machinery types 23KA001, 23KA000, 21FA001, 21FA000, 21LA001, 21LA000, 21SA001, 21SA000, 21KA001 and 21KA000 are in compliance with UK statutory requirement 2008 No. 1597 and with UK statutory requirement 2017 No. 1206.

Hereby, Julius Blum GmbH declares that the radio equipment types 23.A00L83, 23P5020, 21P5020 and Z10C5007 are in compliance with UK statutory requirement 2017 No. 1206.

Hereby, Julius Blum GmbH declares that the electrical and electronic article types Z10ZE000 and Z10ZC000 are in compliance with UK statutory requirement 2016 No. 1091.

Hereby, Julius Blum GmbH declares that the power supply types Z10NA300 and Z10NE030 are in compliance with UK statutory requirement 2016 No. 1101 and UK statutory requirement 2016 No. 1091.

The full text of the UK declaration of conformity is available at the following internet address:

www.blum.com/compliance



Supplier's Declaration of Conformity
47 CFR § 2.1077 Compliance Information

Unique Identifier

Product-Family: SERVO-DRIVE
Product-Types: 23KA00y | $y \in \{0, 1\}$, 23.A00L83
21xA00y | $x \in \{F, L, S\} \wedge y \in \{0, 1\}$, Z10C5007
23P5020, 21P5020 both with PCB 23P502L00
21P5020 with PCB 21P502L00
Z10A3000, Z10C5000
Z10NA300, Z10NE030

Responsible Party-U.S. Contact Information

Blum Inc.
7733 Old Plank Rd.
Stanley, North Carolina
28164

Mr. Christopher Muck
Email: chris.muck@blum.com

FCC Compliance Statement

This device complies with Part 15 of the FCC Rules. Operation is subject to the following two conditions: (1) This device may not cause harmful interference, and (2) this device must accept any interference received, including interference that may cause undesired operation.



Spare parts form

Name of kitchen distributor/cabinet maker: _____

Address: _____

In order to receive your SERVO-DRIVE spare parts as quickly as possible, your SERVO-DRIVE and/or kitchen distributor requires the following data:

Name of kitchen owner: _____

Address: _____

Commission number: _____

Fault description: _____

Part number and batch number of the defective SERVO-DRIVE component:

	Part number	Batch number	Quantity
Blum transformer:	Z10N _____	BN _____	_____
Blum plug-in transformer:	Z10N _____	BN _____	_____
Drive unit:	Z10 _____	BAU _____	_____
Drive unit:	21 _____	BAU _____	_____
Drive unit:	23 _____	BAU _____	_____
SERVO-DRIVE switch:	21 23 _____	BAU _____	_____
Wireless receiver:	Z10C5007	BAU _____	_____



The part number and the batch number can be found here

Blum transformer

Blum plug-in transformer



Drive unit

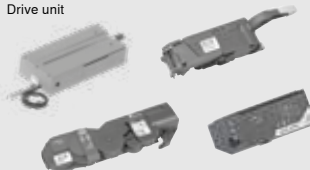

SERVO-DRIVE switch



Wireless receiver



Look for our
FSC™-certified
products

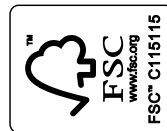

BA-139/4 · 03.21 · © Copyright by Blum

Julius Blum GmbH
Furniture Fittings Mfg.
6973 Höchst, Austria
Tel.: +43 5578 705-0
Fax: +43 5578 705-44
E-mail: info@blum.com
www.blum.com

Our sites in Austria, Poland and China are certified
to the international standards mentioned below.
Our site in the USA is certified to ISO 9001.
Our site in Brazil is certified to ISO 9001 and ISO 14001.



ISO 9001
Certified Quality
System



ISO 14001
Certified Environmental
System



ISO 50001
Certified Energy
System

 **blum**®