



APPLICATION OF CERTIFICATION

For

TTE Technology Inc.

LCD TV

Brand Name	Model Number
TCL	LE43FHDF3300
	LE43FHDF3300TT
	LE43FHDF3300TA

FCC ID: W8ULE43FHDF3300

Prepared for : TTE Technology Inc.
1255 Graphite Drive, Corona, CA 92881, U.S.A.

Prepared By: Audix Technology (Shenzhen) Co., Ltd.
No. 6, Ke Feng Rd., 52 Block,
Shenzhen Science & Industrial Park,
Nantou, Shenzhen, Guangdong, China

Tel: (0755) 26639496
Fax: (0755) 26632877

Report Number : ACS- F12043
Date of Test : Feb.22~Mar.01, 2012
Date of Report : Mar.20, 2012

TABLE OF CONTENTS

Description	Page
Test Report Certification	
1. SUMMARY OF STANDARDS AND RESULTS	1-1
1.1. Description of Standards and Results	1-1
2. GENERAL INFORMATION.....	2-1
2.1. Description of Device (EUT).....	2-1
2.2. Tested Supporting System Details	2-2
2.3. Block diagram of connection between the EUT and simulators.....	2-3
2.4. Test Facility	2-4
2.5. Measurement Uncertainty (95% confidence levels, k=2).....	2-4
3. POWER LINE CONDUCTED EMISSION TEST	3-1
3.1. Test Equipment.....	3-1
3.2. Block Diagram of Test Setup.....	3-1
3.3. Power Line Conducted Emission Test Limits	3-1
3.4. Configuration of EUT on Test.....	3-1
3.5. Operating Condition of EUT	3-2
3.6. Test Procedure	3-2
3.7. Conducted Disturbance at Mains Terminals Test Results	3-2
4. RADIATED EMISSION TEST.....	4-1
4.1. Test Equipment.....	4-1
4.2. Block Diagram of Test Setup.....	4-1
4.3. Radiated Emission Limit	4-2
4.4. EUT Configuration on Test	4-2
4.5. Operating Condition of EUT	4-2
4.6. Test Procedure	4-3
4.7. Radiated Disturbance Test Results	4-3
5. DEVIATION TO TEST SPECIFICATIONS	5-1
6. PHOTOGRAPH	6-1
6.1. Photos of Power Line Conducted Emission Test.....	6-1
6.2. Photos of Radiated Emission Test (In Anechoic Chamber)	6-2
7. PHOTOS OF THE EUT	7-1



TEST REPORT CERTIFICATION

Applicant : TTE Technology Inc.
 Manufacturer : TCL King Electrical Appliances (Huizhou) Co., Ltd.
 EUT Description : LCD TV
 FCC ID : W8ULE43FHDF3300

(A) Model No. & :
 Brand Name

Brand Name	Model Number
TCL	LE43FHDF3300
	LE43FHDF3300TT
	LE43FHDF3300TA

(B) Power Supply : AC 120V/60Hz
 (C) Test Voltage : AC 120V/60Hz

Measurement Standard Used:

FCC Rules and Regulations Part 15 Subpart B Class B 2010, ANSI C63.4: 2009
 ICES-003 Issue 4 February 2004.

The device described above is tested by AUDIX TECHNOLOGY (SHENZHEN) CO., LTD. to determine the maximum emission levels emanating from the device. The maximum emission levels are compared to the FCC Part 15 Subpart B Class B limits both conducted and radiated emissions. The test results are contained in this test report and AUDIX TECHNOLOGY (SHENZHEN) CO., LTD. is assumed of full responsibility for the accuracy and completeness of these tests. This report contains data that are not covered by the NVLAP accreditation.

After the test, our opinion is that EUT compliance with the requirement of the above standards.

This Report is made under FCC Part 2.1075. No modifications were required during testing to bring this product into compliance.

This report applies to above tested sample only. This report shall not be reproduced in parts without written approval of AUDIX TECHNOLOGY (SHENZHEN) CO., LTD.

The report must not be used by the client to claim product certification, approval, or endorsement by NVLAP, NIST, or any agency of the federal government.

Date of Test : Feb.22~ Mar.01, 2012 Report of date: Mar.20, 2012

Prepared by : Cerry He
 Cerry He / Assistant

Reviewed by: Sun Zeng
 Audix Technology (Shenzhen) Co., Ltd. Supervisor

AUDIX
 EMC 部門報告專用章
 Stamp only for EMC Dept. Report
 Signature: Ken Lu 3/20/12

Approved & Authorized Signer : Ken Lu
 Ken Lu / Manager

1. SUMMARY OF STANDARDS AND RESULTS

1.1. Description of Standards and Results

The EUT have been tested according to the applicable standards as referenced below.

EMISSION			
Description of Test Item	Standard	Results	Remarks
Power Line Conducted Emission Test	FCC Part 15: 2010 ANSI C63.4: 2009	PASS	Meets Class B Limit Minimum passing margin is 19.99dB at 6.988MHz
Radiated Emission Test (30-1000MHz)	FCC Part 15: 2010 ANSI C63.4: 2009	PASS	Meets Class B Limit Minimum passing margin is 3.01dB at 858.810MHz
Radiated Emission Test (1-2GHz)	FCC Part 15: 2010 ANSI C63.4: 2009	PASS	Meets Class B Limit Minimum passing margin is 3.14dB at 1485.800MHz

2. GENERAL INFORMATION

2.1. Description of Device (EUT)

Description : LCD TV

Model Number& : Brand Name	Brand Name	Model Number
	TCL	LE43FHDF3300
		LE43FHDF3300TT
		LE43FHDF3300TA

Only the Model Name is difference.

FCC ID : W8ULE43FHDF3300

Applicant : TTE Technology Inc.
1255 Graphite Drive, Corona, CA 92881, U.S.A.

Manufacturer : TCL King Electrical Appliances (Huizhou) Co., Ltd.
Section 19, Zhongkai Development Zone for New & High-Level
Tech Industries, Huizhou, Guangdong Province, China, 516006.

FREQUENCIES USED AND GENERATED WITHIN DEVICE		
X54M1	45-OSC54M-0Y1CR	54MHz
LVDS CLOCK	81.43MHZ	
IF	44MHz	
DC-DC	U302->385KHz	U303->1MHz
DDR	390MHz	
AMP	384KHz	

Power Cord : Unshielded, Undetachable, 2.0m

Date of Test : Feb.22~Mar.01, 2012

Date of Receipt : Feb.22, 2012

Sample Type : Prototype production

2.2. Tested Supporting System Details

	Description	ACS No.	Manufacturer	Model	Serial Number	Approved type
1.	Personal Computer	Test PC M	DELL	Studio 540	224XK2X	<input checked="" type="checkbox"/> FCC DoC <input checked="" type="checkbox"/> BSMI ID:R33002
		Power Cord: Unshielded, Detachable, 1.8m Display Card: HD3450 (DVI+VGA+HDMI)				
2.	USB Keyboard	ACS-EMC- K04R	DELL	SK-8115	CN-ODJ313-7161 6-6BB-049J	<input checked="" type="checkbox"/> FCC DoC <input checked="" type="checkbox"/> BSMI ID: T3A002
		Data Cable: shielded, Undetachable, 2.0m				
3.	Headphone	ACS-EMC-EP03	OVANN	OV880V	N/A	<input type="checkbox"/> FCC ID <input type="checkbox"/> BSMI ID
		Cable: Shielded, Undetachabled, 4.0m				
4.	Printer	ACS-EMC-PT04	HP	C9079A	N/A	<input checked="" type="checkbox"/> FCC DoC <input checked="" type="checkbox"/> BSMI ID: R33001
		USB Cable: Shielded, Detachabled, 1.8m Power Cord: Unshielded, Detachabled, 1.8m Power Adapter: HP, M/N: 0957-2119, BSMI ID: R33030, DC Cable: Unshielded, Detachabled, 1.5m				
5.	USB Mouse	ACS-EMC-M04R	DELL	M056UO	512024282	<input checked="" type="checkbox"/> FCC DoC <input checked="" type="checkbox"/> BSMI ID: R41108
		Data Cable: shielded, Undetachable, 1.8m				
6.	iPod nano	ACS-EMC-IP03	APPLE	A1199	YM711H3LVQ5	<input checked="" type="checkbox"/> FCC DoC <input checked="" type="checkbox"/> BSMI ID: R33057
		Data Cable: Shielded, Detachabled, 1.0m				
7.	HDD	ACS-EMC-HDD03	Terasys	F12-UF	A0100215-53900 30	<input checked="" type="checkbox"/> FCC DoC <input checked="" type="checkbox"/> BSMI ID: 4912A022
		USB Cable: Shielded, Detachable, 1.8m				
8.	Dummy Load (10KΩ & 75Ω)	Component In Cable: Unshielded, Detachabled, 1.5m AV Cable: Unshielded, Detachable, 1.5m Coaxial Cable: Unshielded, Detachable, 1.5m				
9.	D-Sub Cable: Shielded, Detachable, 1.5m HDMI Cable: Shielded, Detachable, 1.5m Audio Cable: Unshielded, Detachable, 1.5m					

2.3. Block diagram of connection between the EUT and simulators

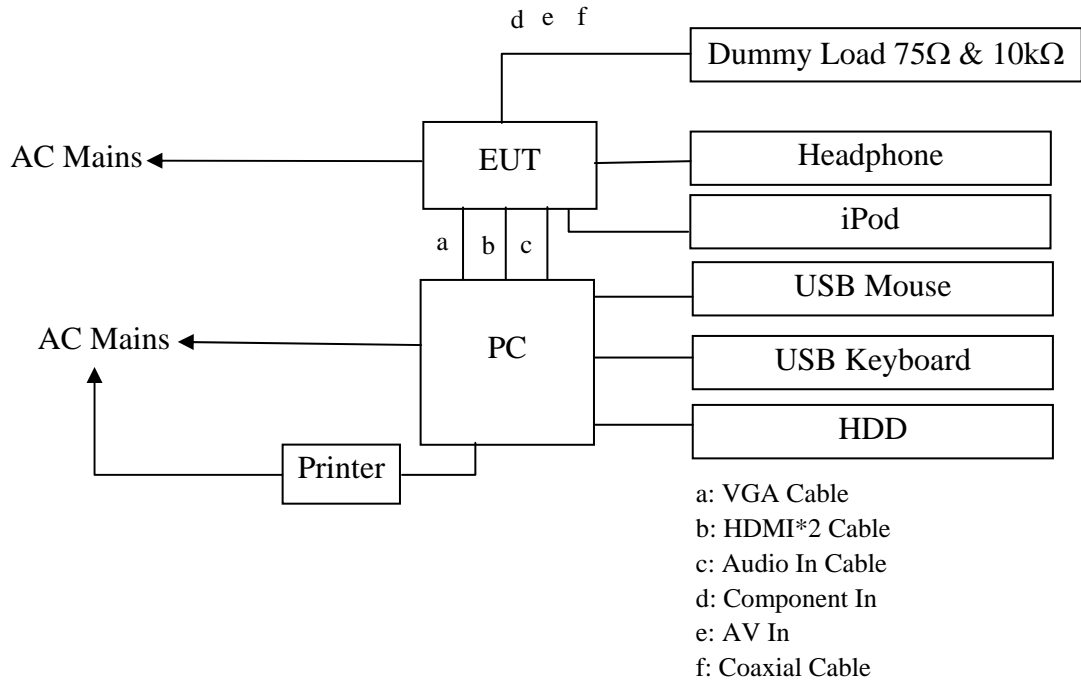

(EUT: LCD TV)

2.4. Test Facility

Site Description

- Name of Firm : Audix Technology (Shenzhen) Co., Ltd.
No. 6, Ke Feng Rd., 52 Block, Shenzhen Science & Industrial Park, Nantou, Shenzhen, Guangdong, China
- 3m Anechoic Chamber : Certificated by FCC, USA
Registration Number: 90454
Valid Date: Mar.31, 2012
- 3m & 10m Anechoic Chamber : Certificated by FCC, USA
Registration Number: 794232
Valid Date: Dec.30, 2012
- EMC Lab. : Certificated by DAkkS, Germany
Registration No: D-PL-12151-01-01
Valid Date: Feb.01, 2014
- Accredited by NVLAP, USA
NVLAP Code: 200372-0
Valid Date: Mar.31, 2012

2.5. Measurement Uncertainty (95% confidence levels, k=2)

Test Item	Uncertainty
Uncertainty for Conduction emission test in No. 1 Conduction	3.2 dB
Uncertainty for Radiation Emission test in 3m chamber	3.6 dB(30~200MHz, Polarize: H)
	3.8 dB(30~200MHz, Polarize: V)
	4.2 dB(200M~1GHz, Polarize: H)
	3.8 dB(200M~1GHz, Polarize: V)
Uncertainty for Radiation Emission test in 3m chamber (1GHz-18GHz)	3.1dB(Distance: 3m Polarize: V)
	3.7 dB(Distance: 3m Polarize: H)
Uncertainty for test site temperature and humidity	3%
	0.6°C

3. POWER LINE CONDUCTED EMISSION TEST

3.1. Test Equipment

Item	Equipment	Manufacturer	Model No.	Serial No.	Last Cal.	Cal. Interval
1.	Test Receiver	Rohde & Schwarz	ESHS10	838693/001	Oct.31, 11	1 Year
2.	L.I.S.N.#1	Rohde & Schwarz	ESH2-Z5	834066/011	Oct.31, 11	1 Year
3.	L.I.S.N.#3	Kyoritsu	KNW-242C	8-1920-1	May.08, 11	1 Year
4.	Terminator	Hubersuhner	50Ω	No. 1	May.08, 11	1 Year
5.	Terminator	Hubersuhner	50Ω	No. 2	May.08, 11	1 Year
6.	RF Cable	Fujikura	3D-2W	No.1	May.08, 11	1Year
7.	Coaxial Switch	Anritsu	MP59B	M50564	May.08, 11	1 Year
8.	Pulse Limiter	Rohde & Schwarz	ESH3-Z2	100341	May.08, 11	1 Year

3.2. Block Diagram of Test Setup

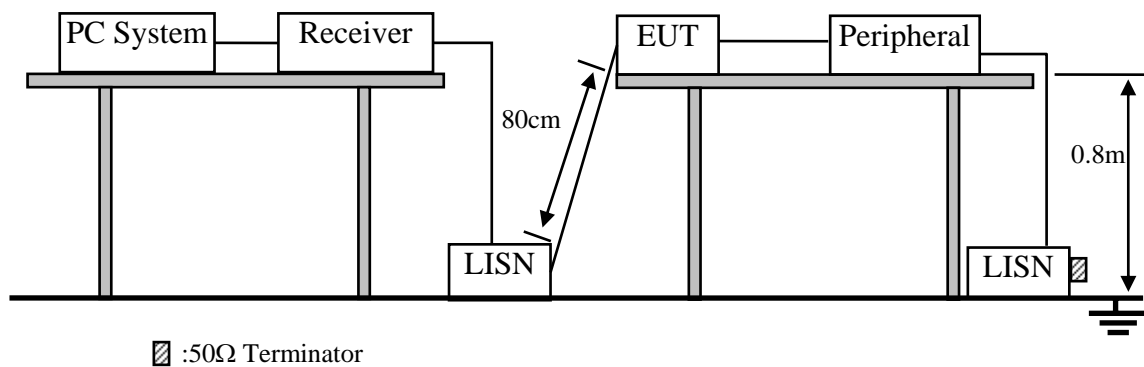

3.3. Power Line Conducted Emission Test Limits

Frequency	Maximum RF Line Voltage	
	Quasi-Peak Level dB(μV)	Average Level dB(μV)
150kHz ~ 500kHz	66 ~ 56*	56 ~ 46*
500kHz ~ 5MHz	56	46
5MHz ~ 30MHz	60	50

- Notes: 1. * Decreasing linearly with logarithm of frequency.
 2. The lower limit shall apply at the transition frequencies.

3.4. Configuration of EUT on Test

The following equipment are installed on Power Line Conducted Emission Test to meet the commission requirement and operating regulations in a manner which tends to maximize its emission characteristics in a normal application.

3.4.1. LCD TV (EUT)

Model Number : LE43FHDF3300
 Serial Number : N/A

3.4.2. Support Equipment : As Tested Supporting System Detail, in Section 2.2.

3.5. Operating Condition of EUT

- 3.5.1. Setup the EUT and simulator as shown as Section 3.2.
- 3.5.2. Turn on the power of all equipment.
- 3.5.3. PC system ran the Self-test program “EMC Test. exe” by windows XP and sent “H” Character to LCD TV (EUT) , the Screen of EUT displayed and filled with “H” pattern, use white letters on a blackground, set the contrast control to maximum, set the brightness control to maximum and measure it.
- 3.5.4. The PC system was running the program “1kHz signal Playing” and sending sound to EUT.
- 3.5.5. The other peripheral devices were driven and operated in turn during all testing.

3.6. Test Procedure

The EUT was placed on a non-metallic table, 80cm above the ground plane. The EUT Power connected to the power mains through a line impedance stabilization network (L.I.S.N. 1#). This provided a 50-ohm coupling impedance for the EUT (Please refer to the block diagram of the test setup and photographs). The other peripheral devices power cord connected to the power mains through a line impedance stabilization network (L.I.S.N.#3). Both sides of power line were checked for maximum conducted interference. In order to find the maximum emission, the relative positions of equipments and all of the interface cables were changed according to ANSI C63.4: 2009 on conducted Emission test.

The bandwidth of test receiver (R&S TEST RECEIVER ESHS10) is set at 10kHz.

The frequency range from 150kHz to 30MHz is checked. The test result are reported on Section 3.7.

3.7. Conducted Disturbance at Mains Terminals Test Results

PASS. (All emissions not reported below are too low against the prescribed limits.)

The EUT with the following test modes were tested and selected to read Q.P values and average values, all the test results are listed in next pages.

EUT: LCD TV Model No. : LE43FHDF3300

Test Date: Feb.27, 2012 Temperature: 25.5°C Humidity: 55%

The details of test modes are as follows :

No.	Test Mode	Input Port	Resolution & Frequency	Reference Test Data No.	
				Line	Neutral
1.	PC Mode	VGA	640*480 @60Hz	#37	#38
2.			1024*768 @ 60Hz	#39	#40
3.			1920*1080@60Hz	#41	#42
4. ✖		HDMI 1	1920*1080@60Hz	#43	#44
5.		HDMI 2	1920*1080@60Hz	#45	#46

(✖ Worst test mode)

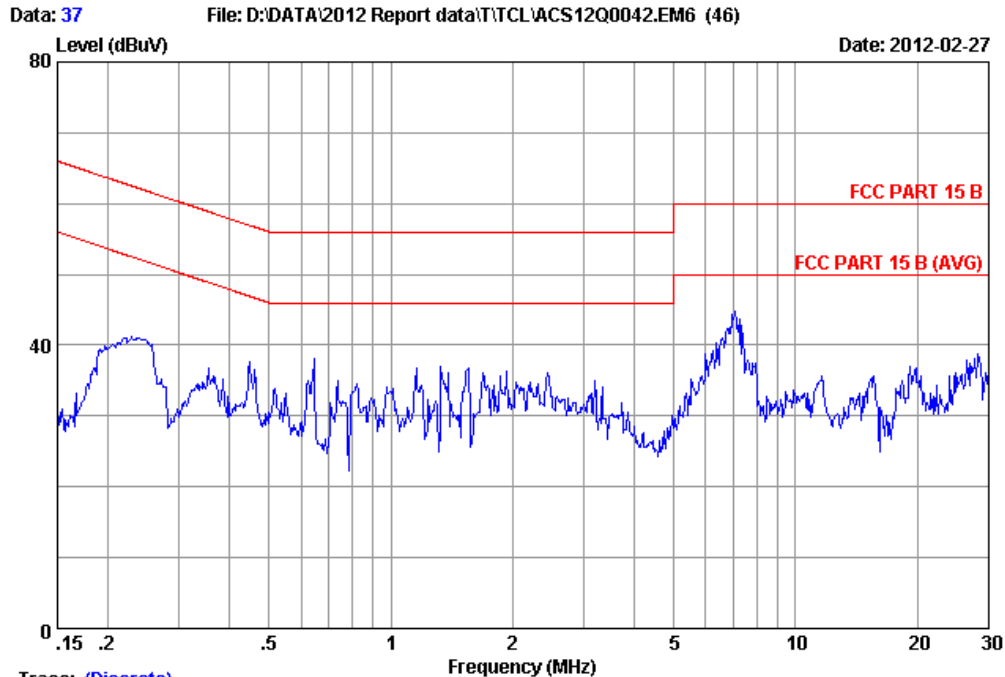

Trace: (Discrete)
 Site no :1#conduction Data No :37
 Dis./Ant. **: 2011 ESH2-25 LINE
 Limit :FCC PART 15 B
 Env./Ins. :25.5°C/55% Engineer :Jerry
 EUT :LCD TV M/N:LE43FHDF3300
 Power Rating :AC 120V/60Hz
 Test Mode :Running "H" Pattern And 1KHz Playing
 :VGA:640*480@60Hz

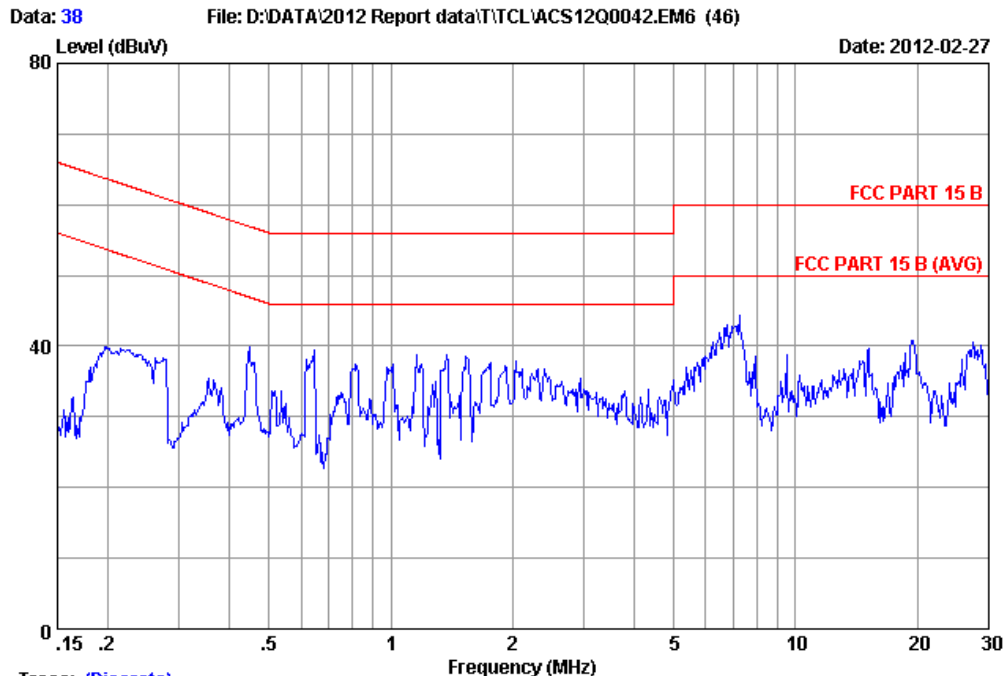

Trace: (Discrete)
 Site no :1#conduction Data No :38
 Dis./Ant. **: 2011 ESH2-25 NEUTRAL
 Limit :FCC PART 15 B
 Env./Ins. :25.5°C/55% Engineer :Jerry
 EUT :LCD TV M/N:LE43FHDF3300
 Power Rating :AC 120V/60Hz
 Test Mode :Running "H" Pattern And 1KHz Playing
 :VGA:640*480@60Hz

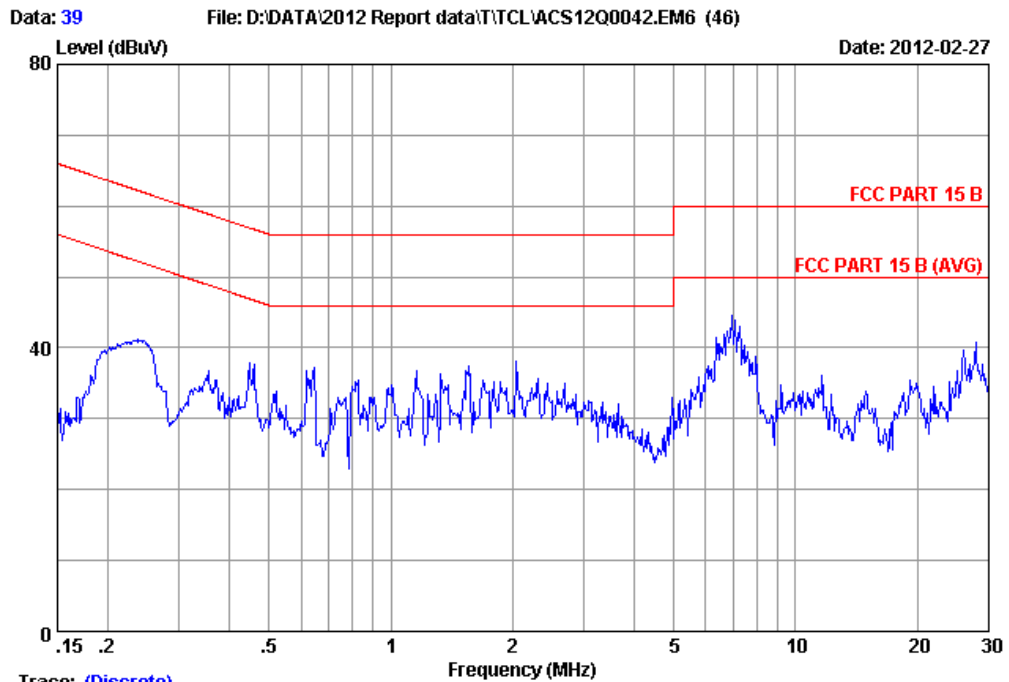

Trace: (Discrete)

Site no :1#conduction Data No :39

Dis./Ant. **: 2011 ESH2-25 LINE

Limit :FCC PART 15 B

Env./Ins. :25.5°C/55% Engineer :Jerry

EUT :LCD TV M/N:LE43FHDF3300

Power Rating :AC 120V/60Hz

Test Mode :Running "H" Pattern And 1KHz Playing

:VGA:1024*768@60Hz

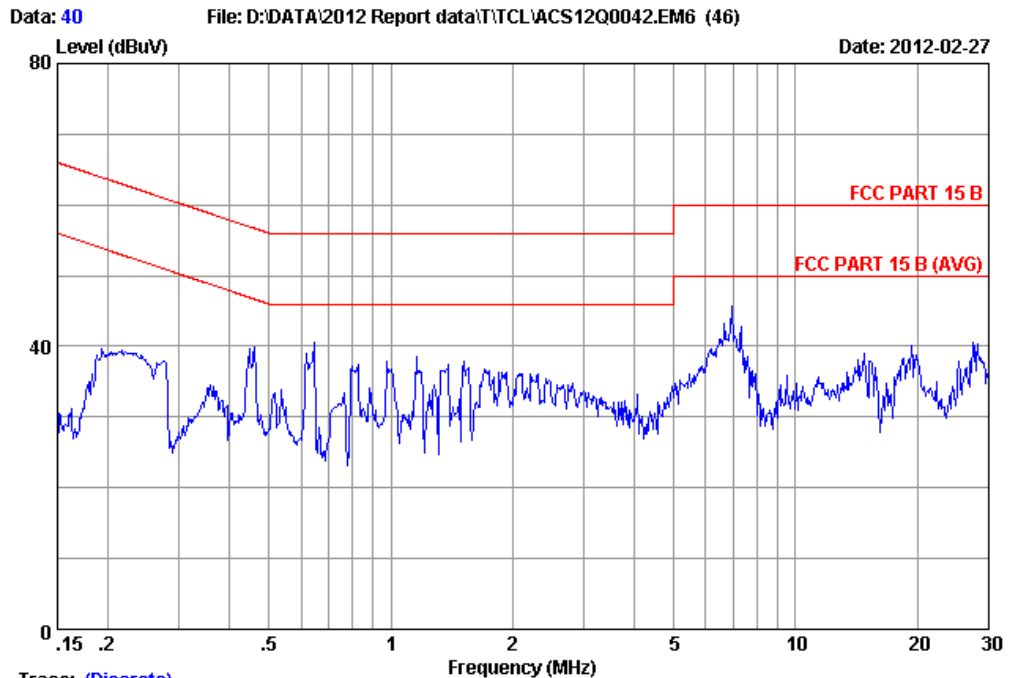

Trace: (Discrete)

Site no :1#conduction Data No :40

Dis./Ant. **: 2011 ESH2-25 NEUTRAL

Limit :FCC PART 15 B

Env./Ins. :25.5°C/55% Engineer :Jerry

EUT :LCD TV M/N:LE43FHDF3300

Power Rating :AC 120V/60Hz

Test Mode :Running "H" Pattern And 1KHz Playing

:VGA:1024*768@60Hz

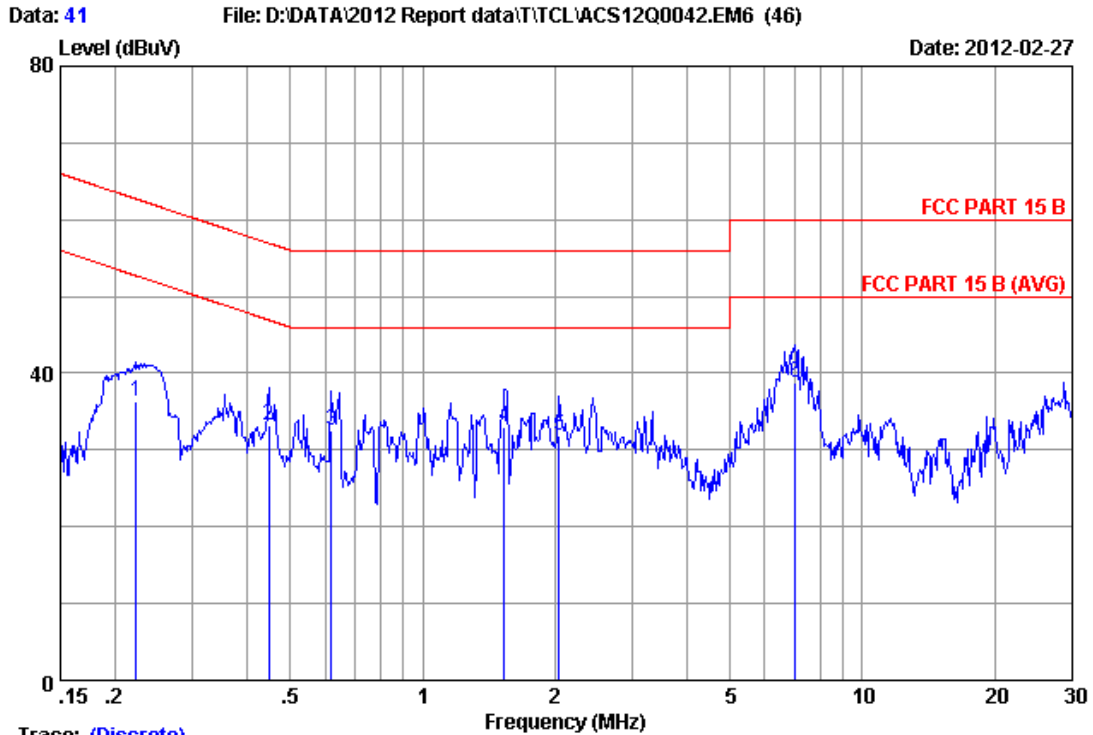

Trace: (Discrete)

Site no :1#conduction Data No :41
 Dis./Ant. **: 2011 ESH2-Z5 LINE
 Limit :FCC PART 15 B
 Env./Ins. :25.5*C/55% Engineer :Jerry
 EUT :LCD TV M/N:LE43FHDF3300
 Power Rating :AC 120V/60Hz
 Test Mode :Running "H" Pattern And 1KHz Playing
 :VGA:1920*1080@60Hz

No	Freq (MHz)	LISN Factor (dB)	Cable Loss (dB)	Reading (dBuV)	Emission Level (dBuV)	Limits (dBuV)	Margin (dB)	Remark
1	0.22319	0.15	9.86	26.38	36.39	62.70	26.31	QP
2	0.44679	0.16	9.87	23.06	33.09	56.93	23.84	QP
3	0.62054	0.16	9.87	22.54	32.57	56.00	23.43	QP
4	1.535	0.19	9.90	22.81	32.90	56.00	23.10	QP
5	2.044	0.20	9.92	21.79	31.91	56.00	24.09	QP
6	7.025	0.30	10.04	28.37	38.71	60.00	21.29	QP

Remarks: 1.Emission Level=LISN Factor+Cable Loss(Include 10dB pulse limit)+Reading.
 2.If the average limit is met when using a quasi-peak detector. the EUT shall be deemed to meet both limits and measurement with average detector is unnecessary.

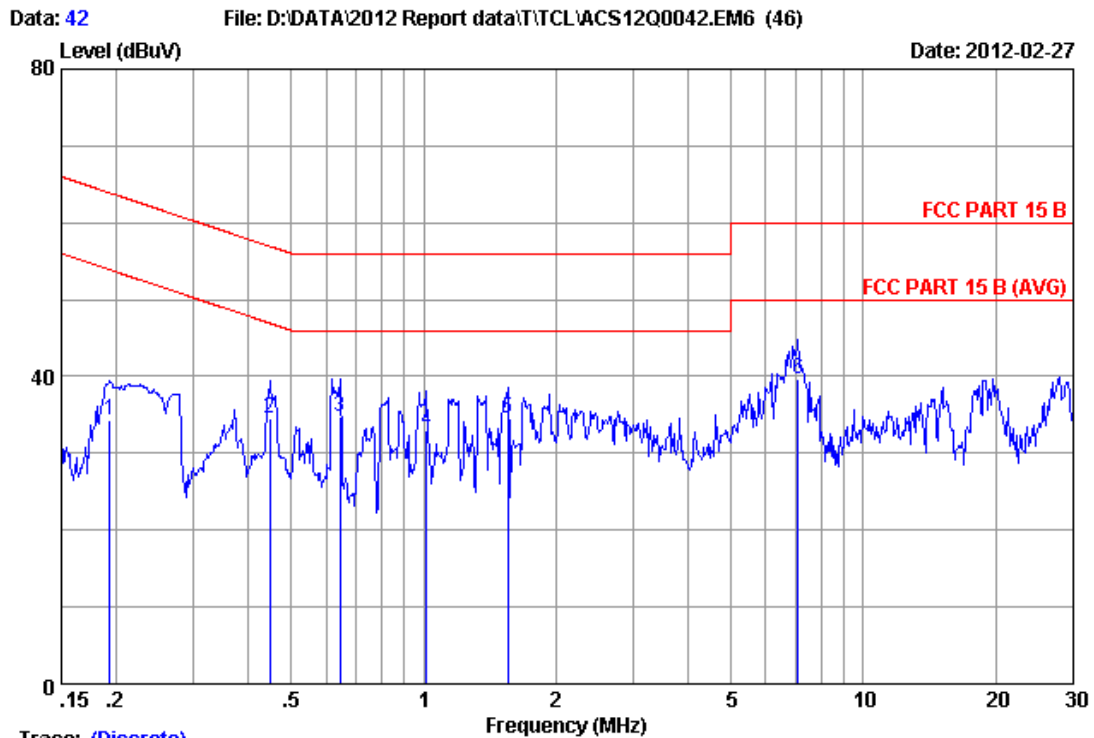

Trace: (Discrete)

Site no : 1#conduction Data No : 42
 Dis./Ant. : ** 2011 ESH2-25 NEUTRAL
 Limit : FCC PART 15 B
 Env./Ins. : 25.5°C/55% Engineer : Jerry
 EUT : LCD TV M/N:LE43FHDF3300
 Power Rating : AC 120V/60Hz
 Test Mode : Running "H" Pattern And 1KHz Playing
 : VGA:1920*1080@60Hz

No	Freq (MHz)	LISN Factor (dB)	Cable Loss (dB)	Reading (dBuV)	Emission Level (dBuV)	Limits (dBuV)	Margin (dB)	Remark
1	0.19344	0.14	9.86	24.37	34.37	63.89	29.52	QP
2	0.44679	0.15	9.87	24.51	34.53	56.93	22.40	QP
3	0.64398	0.16	9.87	24.71	34.74	56.00	21.26	QP
4	1.016	0.17	9.88	23.02	33.07	56.00	22.93	QP
5	1.552	0.19	9.90	24.45	34.54	56.00	21.46	QP
6	7.100	0.28	10.04	29.43	39.75	60.00	20.25	QP

Remarks: 1. Emission Level=LISN Factor+Cable Loss(Include 10dB pulse limit)+Reading.
 2. If the average limit is met when using a quasi-peak detector, the EUT shall be deemed to meet both limits and measurement with average detector is unnecessary.

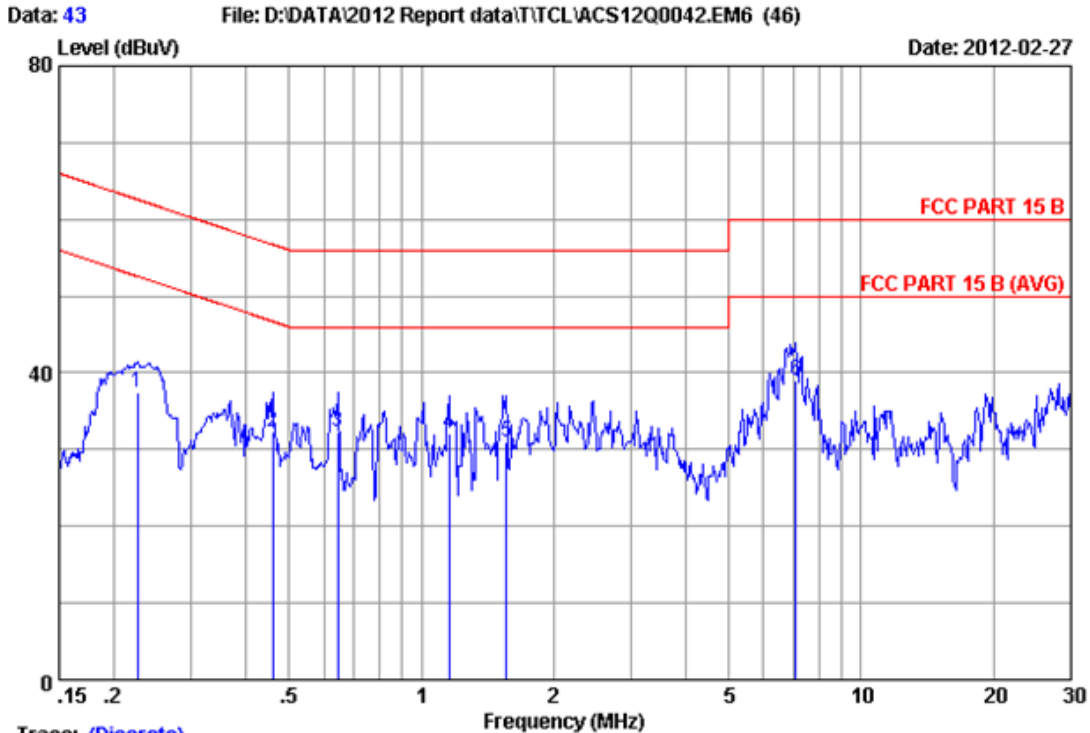

Trace: (Discrete)

Site no :1#conduction Data No :43
 Dis./Ant. **: 2011 ESH2-25 LINE
 Limit :FCC PART 15 B
 Env./Ins. :25.5°C/55% Engineer :Jerry
 EUT :LCD TV M/N:LE43FHDF3300
 Power Rating :AC 120V/60Hz
 Test Mode :Running "H" Pattern And 1KHz Playing
 :HDMI 1:1920*1080@60Hz

No	Freq (MHz)	LISN Factor (dB)	Cable Loss (dB)	Reading (dBuV)	Emission Level (dBuV)	Limits (dBuV)	Margin (dB)	Remark
1	0.22556	0.15	9.86	27.42	37.43	62.61	25.18	QP
2	0.45878	0.16	9.87	22.37	32.40	56.71	24.31	QP
3	0.64398	0.16	9.87	22.30	32.33	56.00	23.67	QP
4	1.153	0.17	9.89	21.92	31.98	56.00	24.02	QP
5	1.560	0.19	9.90	20.93	31.02	56.00	24.98	QP
6	7.100	0.30	10.04	28.65	38.99	60.00	21.01	QP

Remarks: 1. Emission Level=LISN Factor+Cable Loss(Include 10dB pulse limit)+Reading.
 2. If the average limit is met when using a quasi-peak detector, the EUT shall be deemed to meet both limits and measurement with average detector is unnecessary.

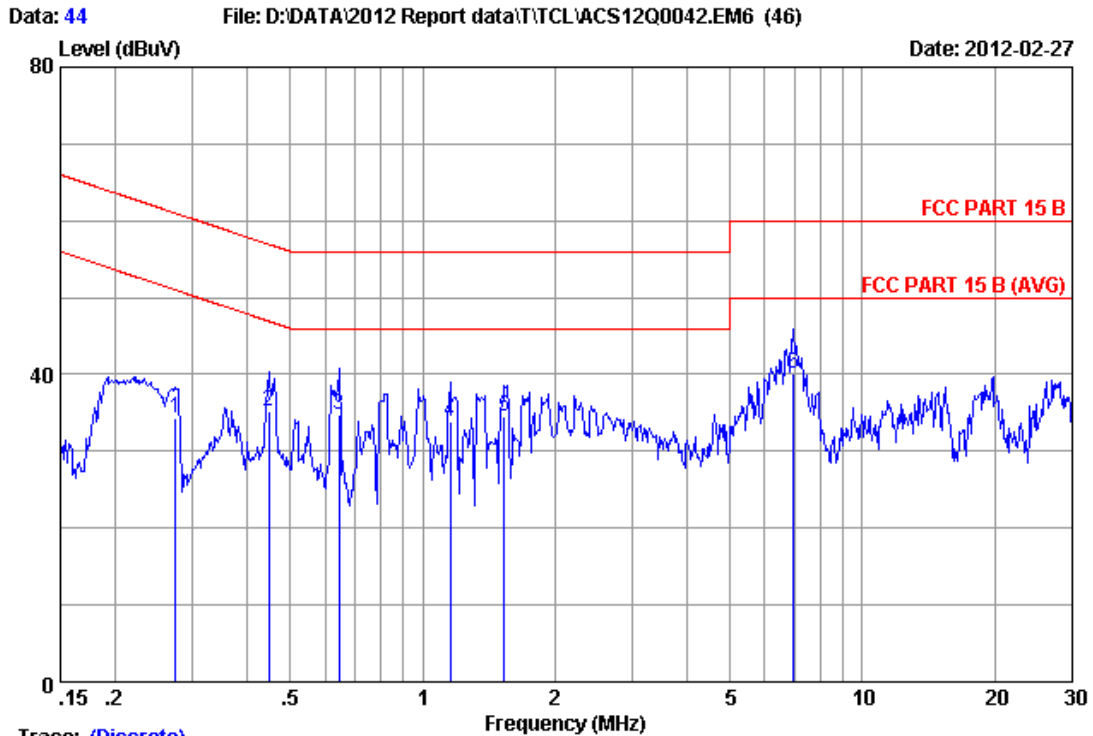

Trace: (Discrete)

Site no : 1#conduction Data No : 44
 Dis./Ant. : ** 2011 ESH2-25 NEUTRAL
 Limit : FCC PART 15 B
 Env./Ins. : 25.5°C/55% Engineer : Jerry
 EUT : LCD TV M/N:LE43FHDF3300
 Power Rating : AC 120V/60Hz
 Test Mode : Running "H" Pattern And 1KHz Playing
 : HDMI 1:1920*1080@60Hz

No	Freq (MHz)	LISN Factor (dB)	Cable Loss (dB)	Reading (dBuV)	Emission Level (dBuV)	Limits (dBuV)	Margin (dB)	Remark
1	0.27442	0.14	9.86	24.26	34.26	60.98	26.72	QP
2	0.44679	0.15	9.87	25.23	35.25	56.93	21.68	QP
3	0.64398	0.16	9.87	24.67	34.70	56.00	21.30	QP
4	1.153	0.17	9.89	23.88	33.94	56.00	22.06	QP
5	1.535	0.19	9.90	24.49	34.58	56.00	21.42	QP
6	6.988	0.28	10.04	29.69	40.01	60.00	19.99	QP

Remarks: 1. Emission Level=LISN Factor+Cable Loss(Include 10dB pulse limit)+Reading.
 2. If the average limit is met when using a quasi-peak detector, the EUT shall be deemed to meet both limits and measurement with average detector is unnecessary.

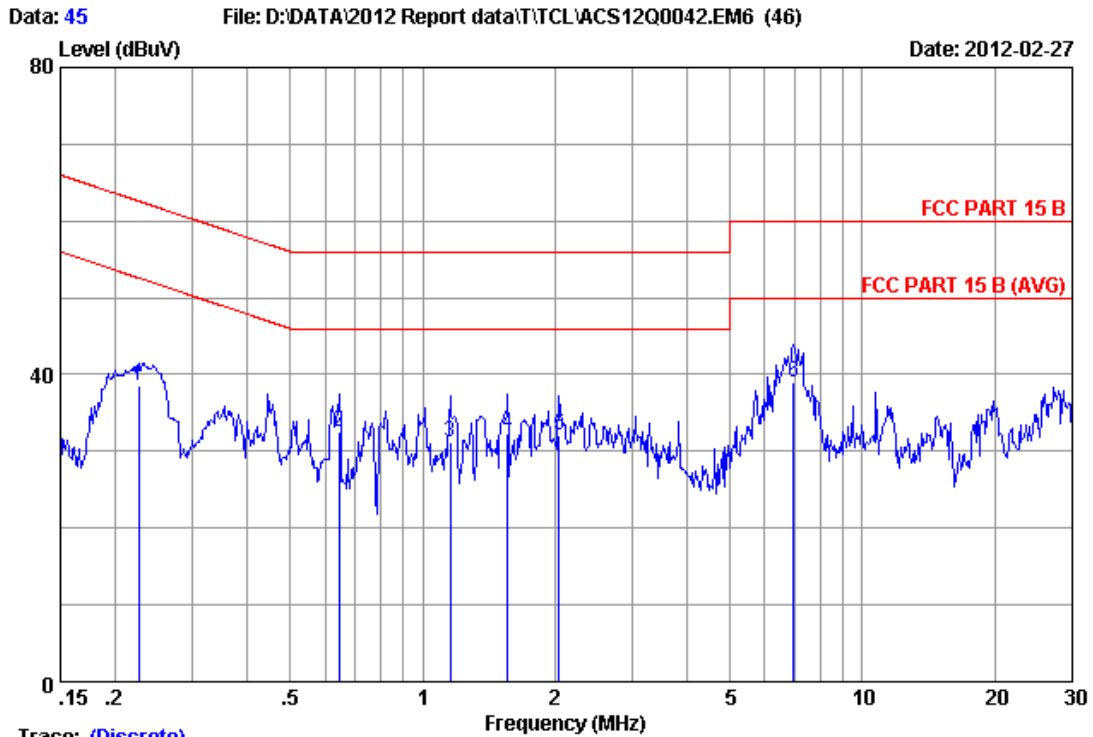

Trace: (Discrete)

Site no :1#conduction Data No :45
 Dis./Ant. **: 2011 ESH2-25 LINE
 Limit :FCC PART 15 B
 Env./Ins. :25.5*C/55% Engineer :Jerry
 EUT :LCD TV M/N:LE43FHDF3300
 Power Rating :AC 120V/60Hz
 Test Mode :Running "H" Pattern And 1KHz Playing
 :HDMI 2:1920*1080@60Hz

No	Freq (MHz)	LISN Factor (dB)	Cable Loss (dB)	Reading (dBuV)	Emission Level (dBuV)	Limits (dBuV)	Margin (dB)	Remark
1	0.22556	0.15	9.86	28.50	38.51	62.61	24.10	QP
2	0.64398	0.16	9.87	22.40	32.43	56.00	23.57	QP
3	1.153	0.17	9.89	21.08	31.14	56.00	24.86	QP
4	1.560	0.19	9.90	22.33	32.42	56.00	23.58	QP
5	2.044	0.20	9.92	22.07	32.19	56.00	23.81	QP
6	6.988	0.30	10.04	28.56	38.90	60.00	21.10	QP

Remarks: 1.Emission Level=LISN Factor+Cable Loss(Include 10dB pulse limit)+Reading.
 2.If the average limit is met when using a quasi-peak detector. the EUT shall be deemed to meet both limits and measurement with average detector is unnecessary.

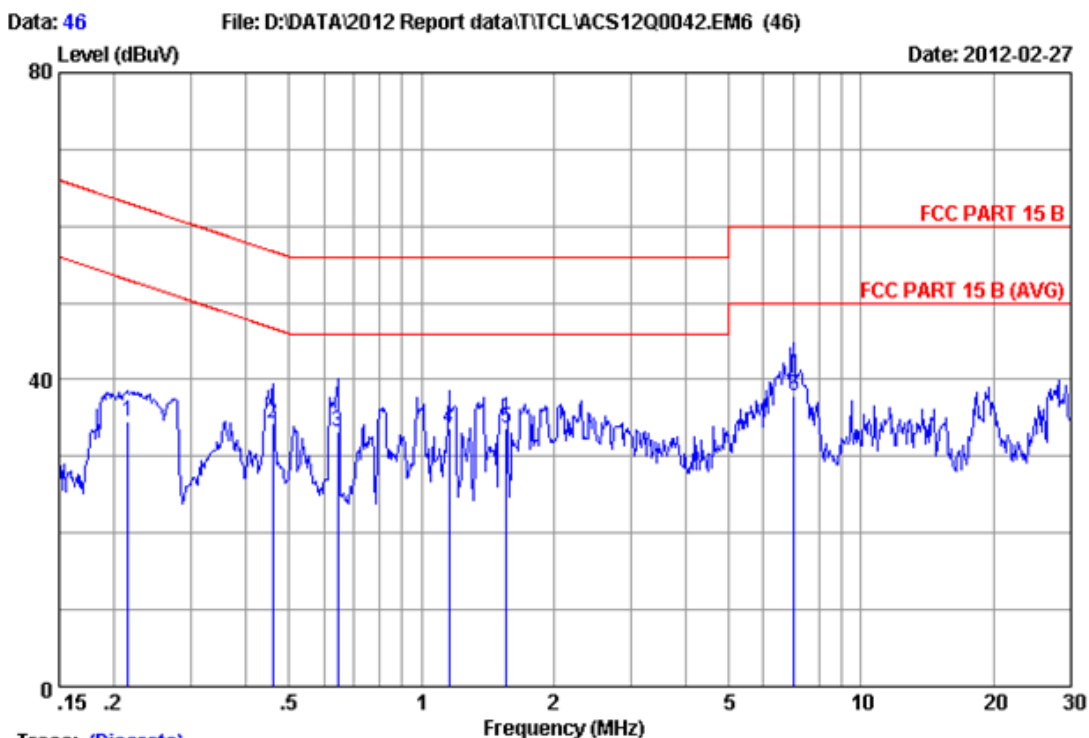

Trace: (Discrete)

Site no :1#conduction Data No :46
 Dis./Ant. **: 2011 ESH2-25 NEUTRAL
 Limit :FCC PART 15 B
 Env./Ins. :25.5°C/55% Engineer :Jerry
 EUT :LCD TV M/N:LE43FHDF3300
 Power Rating :AC 120V/60Hz
 Test Mode :Running "H" Pattern And 1KHz Playing
 :HDMI 2:1920*1080@60Hz

No	Freq (MHz)	LISN Factor (dB)	Cable Loss (dB)	Reading (dBuV)	Emission Level (dBuV)	Limits (dBuV)	Margin (dB)	Remark
1	0.21506	0.14	9.86	24.64	34.64	63.01	28.37	QP
2	0.45878	0.15	9.87	24.34	34.36	56.71	22.35	QP
3	0.64398	0.16	9.87	23.19	33.22	56.00	22.78	QP
4	1.153	0.17	9.89	23.54	33.60	56.00	22.40	QP
5	1.560	0.19	9.90	23.65	33.74	56.00	22.26	QP
6	7.025	0.28	10.04	27.47	37.79	60.00	22.21	QP

Remarks: 1. Emission Level=LISN Factor+Cable Loss(Include 10dB pulse limit) +Reading.
 2. If the average limit is met when using a quasi-peak detector, the EUT shall be deemed to meet both limits and measurement with average detector is unnecessary.

4. RADIATED EMISSION TEST

4.1. Test Equipment

4.1.1. For frequency range 30MHz~1000MHz

Item	Equipment	Manufacturer	Model No.	Serial No.	Last Cal.	Cal. Interval
1	3#Chamber	AUDIX	N/A	N/A	Nov.28,11	1 Year
2	EMI Spectrum	Agilent	E4407B	MY41440292	May.08, 11	1 Year
3	Test Receiver	Rohde & Schwarz	ESVS10	834468/011	May.08, 11	1 Year
4	Amplifier	HP	8447D	2648A04738	May.08, 11	1 Year
5	Bilog Antenna	Schaffner	CBL6111C	2598	Oct.26, 10	1.5 Year
6	RF Cable	MIYAZAKI	CFD400-NL	3# Chamber No.1	Dec.06, 11	1/2Year
7	Coaxial Switch	Anritsu	MP59B	M74389	May.08, 11	1 Year

4.1.2. For frequency range 1GHz~2GHz

Item	Equipment	Manufacturer	Model No.	Serial No.	Last Cal.	Cal. Interval
1	Spectrum Analyzer	Agilent	E4407B	MY41440292	May.08, 11	1 Year
2	Horn Antenna	EMCO	3115	9607-4877	July.01, 11	1 Year
3	Amplifier	Agilent	8449B	3008A00863	May.08, 11	1 Year
4	RF Cable	Hubersuhner	SUCOFLEX106	77980/6	Dec.06, 11	0.5Year
5	RF Cable	Hubersuhner	SUCOFLEX106	77977/6	Dec.06, 11	0.5Year

4.2. Block Diagram of Test Setup

For frequency range 30MHz-1000MHz

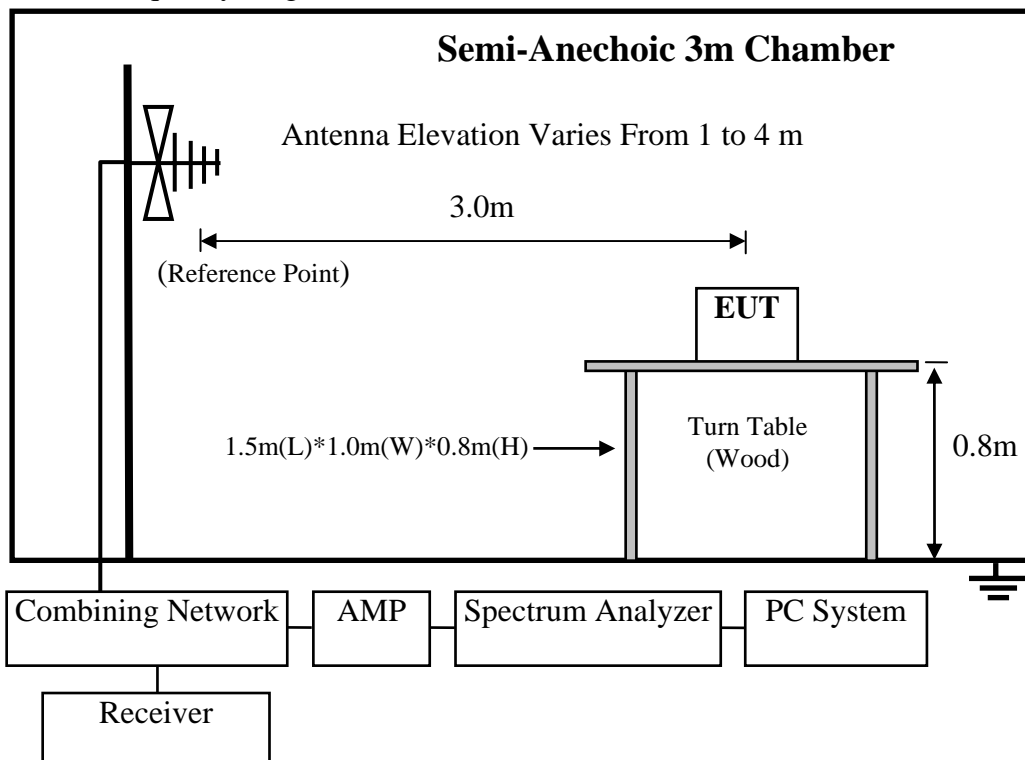

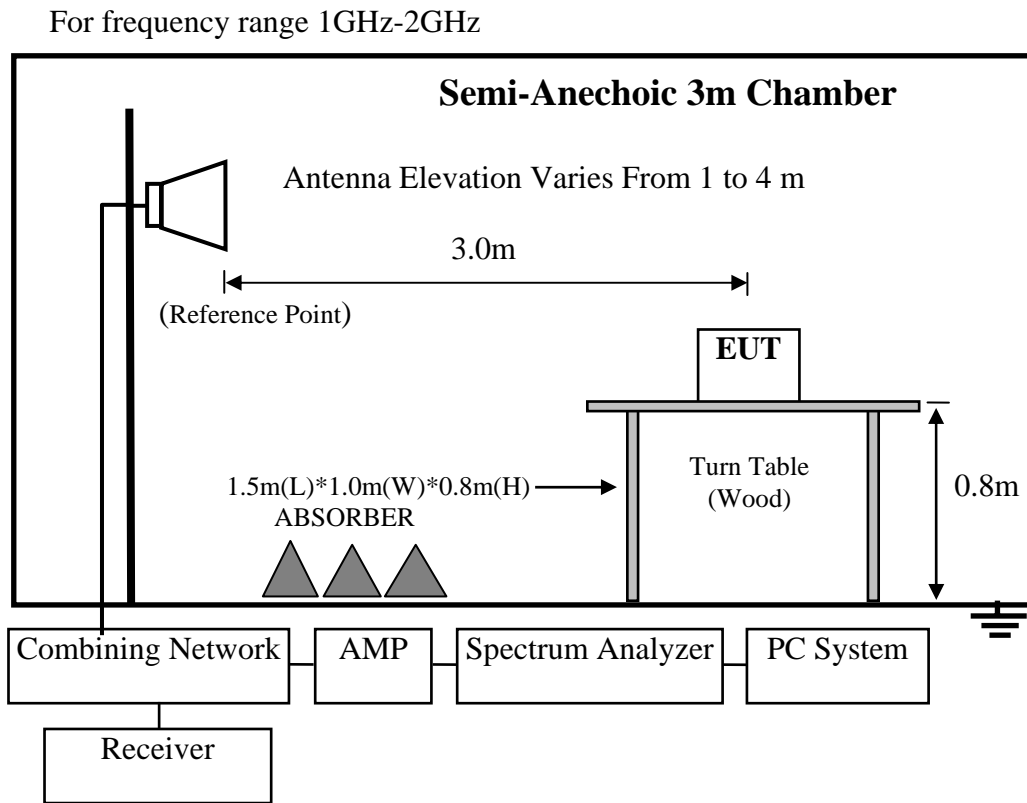

4.3. Radiated Emission Limit

Frequency MHz	Distance (Meters)	Field Strengths Limits dB(μV)/m
30 ~ 88	3	40.0
88 ~ 216	3	43.5
216 ~ 960	3	46.0
960 ~ 1000	3	54.0
Above 1000	3	74(Peak)54(Average)

- Remark: (1) Emission level = Antenna Factor + Cable Loss + Reading
Emission level = Antenna Factor - Amp Factor + Cable Loss + Reading (above 1000MHz)
- (2) The smaller limit shall apply at the cross point between two frequency bands.
- (3) Distance is the distance in meters between the measuring instrument, antenna and the closest point of any part of the device or system.

4.4. EUT Configuration on Test

The configurations of EUT are listed in Section 3.4

4.5. Operating Condition of EUT

Same as Conducted Emission test that is listed in Section 3.5. except the test set up replaced by Section 4.2.

4.6. Test Procedure

The EUT was placed on a non-metallic table, 80 cm above the ground plane inside a semi-anechoic chamber. An antenna was located 3m from the EUT on an adjustable mast. A pre-scan was first performed in order to find prominent radiated emissions. For final emissions measurements at each frequency of interest, the EUT were rotated and the antenna height was varied between 1m and 4m in order to maximize the emission. Measurements in both horizontal and vertical polarities were made and the data was recorded. In order to find the maximum emission, the relative positions of equipments and all of the interface cables were changed according to ANSI C63.4: 2009 on Radiated Emission test.

The bandwidth of the EMI test receiver (R&S ESVS10) is set at 120kHz for frequency range from 30MHz to 1000 MHz.

The bandwidth of the Spectrum's RBW is set at 1MHz and VBW is set at 3MHz for peak emissions measurement above 1GHz and 1MHz RBW, 10Hz VBW for average emissions measure above 1GHz.

4.7. Radiated Disturbance Test Results

PASS. (All emissions not reported below are too low against the prescribed limits.)

EUT: LCD TV Model No. : LE43FHDF3300

For frequency range 30MHz~1000MHz

The EUT with the following test modes were tested and selected to read Q.P values, all the test results are listed in next pages.

Test Date: Feb.22, 2012 Temperature: 24°C Humidity: 56%

The details of test modes are as follows :

No.	Test Mode	Input Port	Resolution & Frequency	Reference Test Data No.	
				Horizontal	Vertical
1.	PC Mode	VGA	640*480 @60Hz	#45	#46
2.			1024*768 @ 60Hz	#44	#43
3.			1920*1080@60Hz	#41	#42
4. ※		HDMI 1	1920*1080@60Hz	#37	#38
5.		HDMI 2	1920*1080@60Hz	#40	#39

(※ Worst test mode)

For frequency range 1GHz~2GHz

The EUT with below test mode were measured within Anechoic Chamber and the test results listed in next pages

Note: For all the emissions above 1GHz, the peak measured level comply with peak limit, so the average level were deemed to comply with average limit.

Test Date: Mar.01, 2012 Temperature: 24°C Humidity: 56%

NO.	Test Mode	Resolution & Frequency	Reference Test Data No.	
			Horizontal	Vertical
1.	VGA	1920*1080 @60Hz	#47, #48	#49, #50
2.	HDMI 1	1920*1080 @60Hz	#53, #54	#51, #52
3.	HDMI 2	1920*1080 @60Hz	#55, #56	#57, #58

30MHz~1000MHz

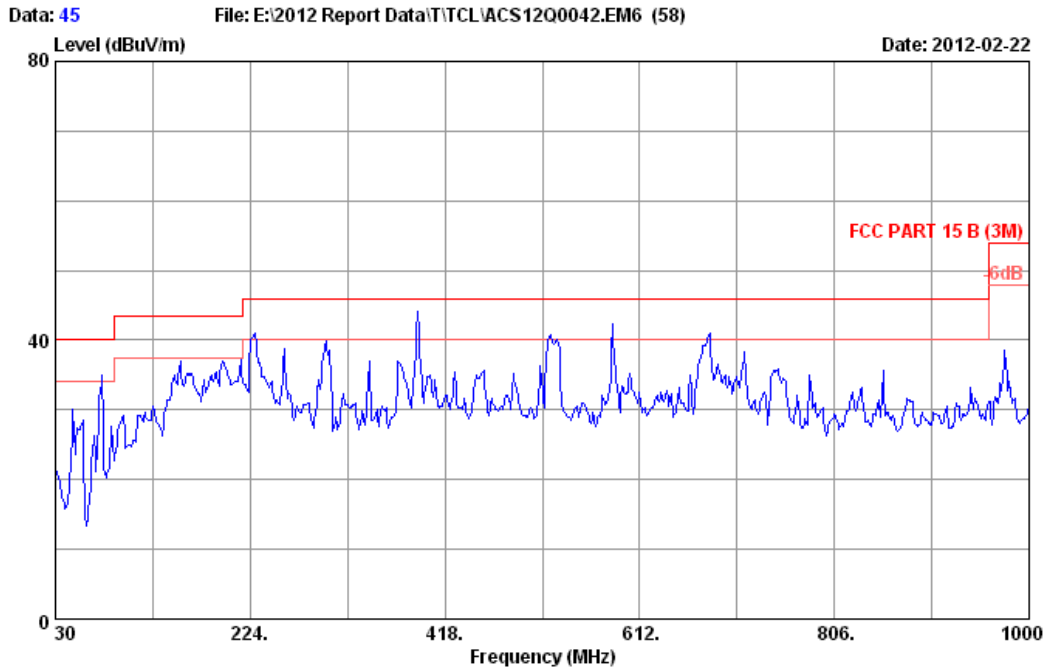

Site no. : 3m Chamber Data no. : 45
 Dis. / Ant. : 3m 2010 CBL6111C 2598 Ant. pol. : HORIZONTAL
 Limit : FCC PART 15 B (3M)
 Env. / Ins. : 24°C/56% Engineer : Victory-Cao
 EUT : LCD TV M/N:LE43FHDF3300
 Power rating : AC 120V/60Hz
 Test Mode : Running "H" Pattern And 1KHz Playing
 VGA:640*480@60Hz

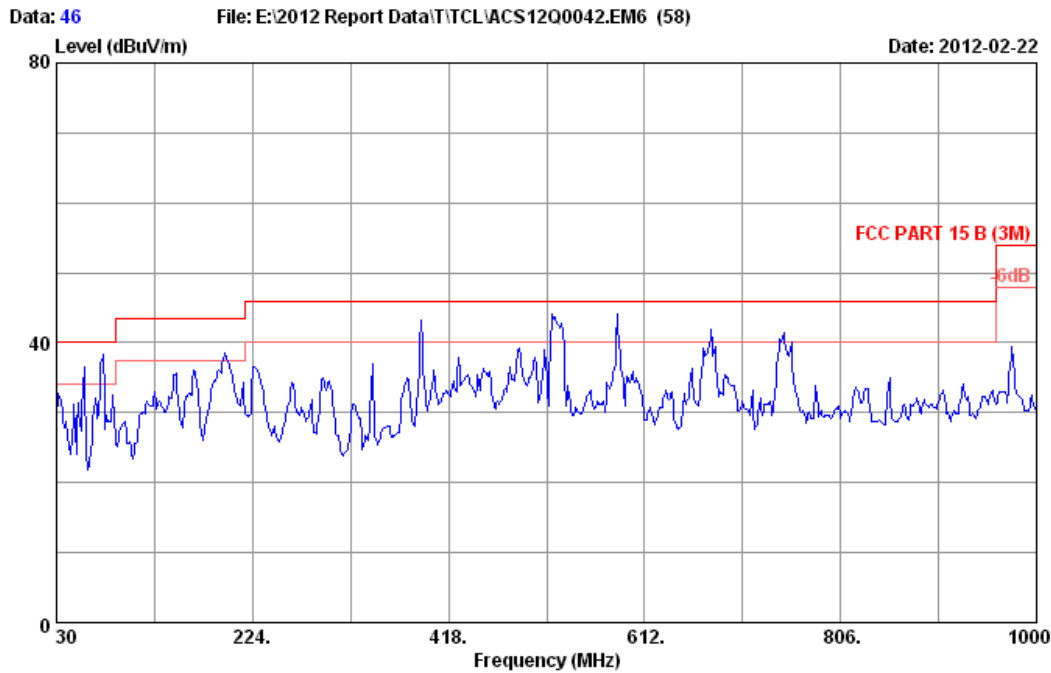

Site no. : 3m Chamber Data no. : 46
 Dis. / Ant. : 3m 2010 CBL6111C 2598 Ant. pol. : VERTICAL
 Limit : FCC PART 15 B (3M)
 Env. / Ins. : 24°C/56% Engineer : Victory-Cao
 EUT : LCD TV M/N:LE43FHDF3300
 Power rating : AC 120V/60Hz
 Test Mode : Running "H" Pattern And 1KHz Playing
 VGA:640*480@60Hz

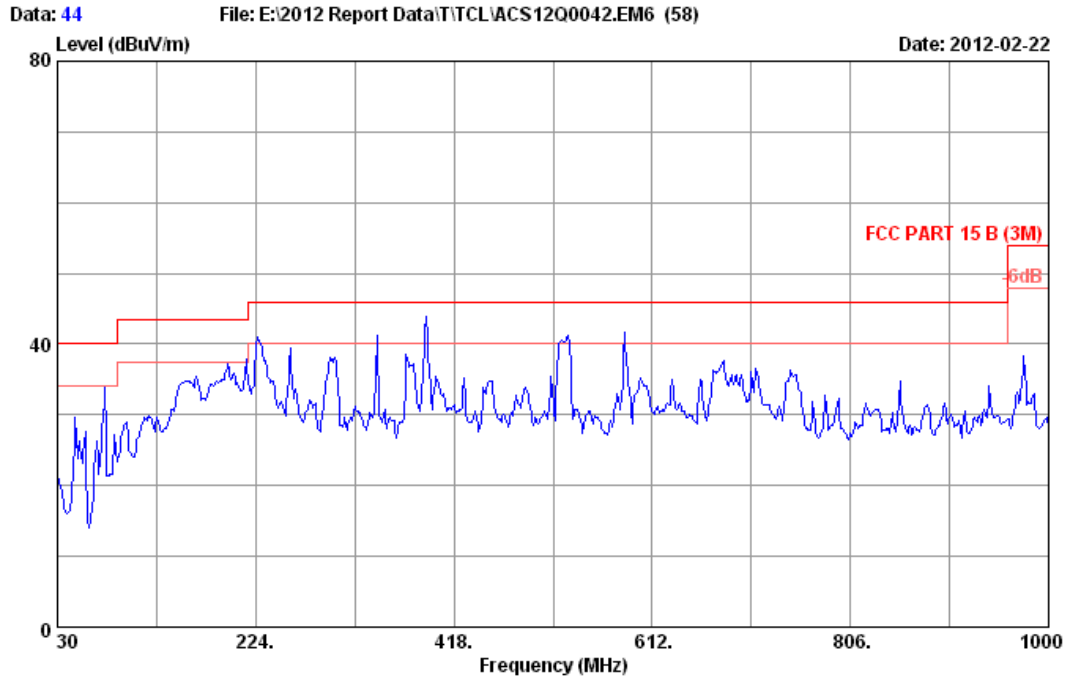

Site no. : 3m Chamber Data no. : 44
 Dis. / Ant. : 3m 2010 CBL6111C 2598 Ant. pol. : HORIZONTAL
 Limit : FCC PART 15 B (3M)
 Env. / Ins. : 24°C/56% Engineer : Victory-Cao
 EUT : LCD TV M/N:LE43FHDF3300
 Power rating : AC 120V/60Hz
 Test Mode : Running "H" Pattern And 1KHz Playing
 VGA:1024*768@60Hz

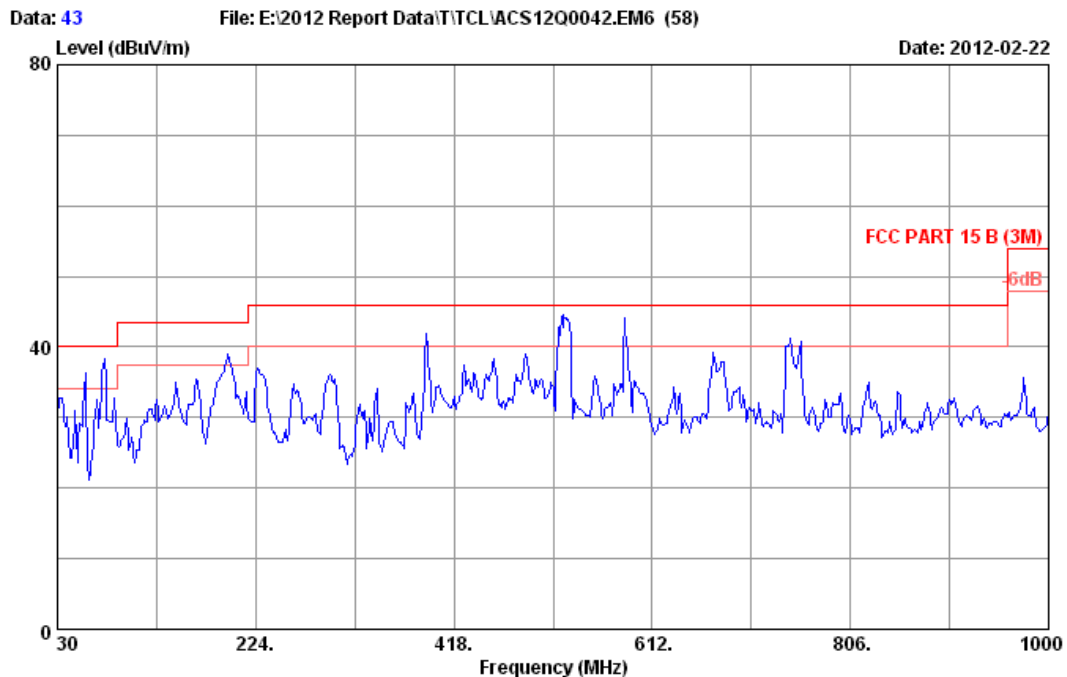

Site no. : 3m Chamber Data no. : 43
 Dis. / Ant. : 3m 2010 CBL6111C 2598 Ant. pol. : VERTICAL
 Limit : FCC PART 15 B (3M)
 Env. / Ins. : 24°C/56% Engineer : Victory-Cao
 EUT : LCD TV M/N:LE43FHDF3300
 Power rating : AC 120V/60Hz
 Test Mode : Running "H" Pattern And 1KHz Playing
 VGA:1024*768@60Hz

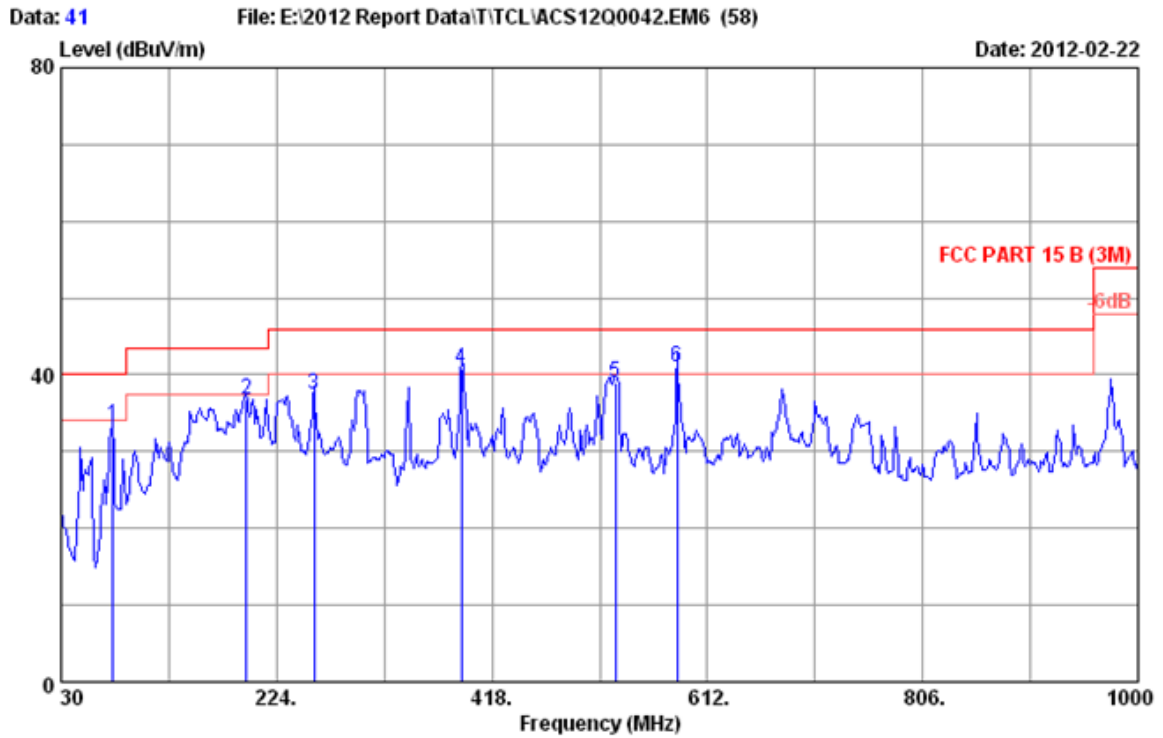

Site no. : 3m Chamber Data no. : 41
 Dis. / Ant. : 3m 2010 CBL6111C 2598 Ant. pol. : HORIZONTAL
 Limit : FCC PART 15 B (3M)
 Env. / Ins. : 24°C/56% Engineer : Victory-Cao
 EUT : LCD TV M/N:LE43FHDF3300
 Power rating : AC 120V/60Hz
 Test Mode : Running "H" Pattern And 1KHz Playing
 VGA:1920*1080@60Hz

No.	Freq. (MHz)	Ant. Factor (dB/m)	Cable Loss (dB)	Reading (dBUV)	Emission Level (dBUV/m)	Limits (dBUV/m)	Margin (dB)	Remark
1	76.560	7.47	0.56	25.50	33.53	40.00	6.47	QP
2	196.840	9.82	0.91	26.04	36.77	43.50	6.73	QP
3	257.950	13.60	1.19	22.72	37.51	46.00	8.49	QP
4	390.840	16.31	1.34	23.17	40.82	46.00	5.18	QP
5	529.550	18.30	1.60	19.03	38.93	46.00	7.07	QP
6	585.030	19.70	1.58	19.70	40.98	46.00	5.02	QP

Remarks: 1. Emission Level= Antenna Factor + Cable Loss + Reading.
 2. The emission levels that are 20dB below the official limit are not reported.

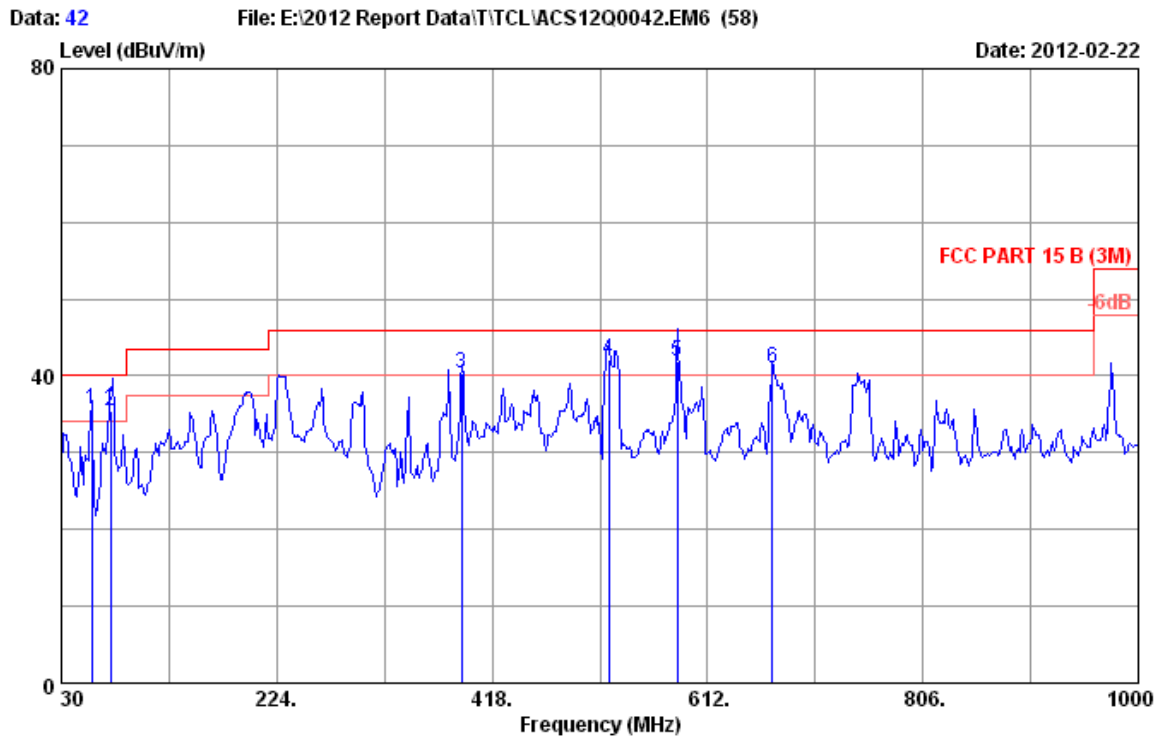

Site no. : 3m Chamber Data no. : 42
 Dis. / Ant. : 3m 2010 CBL6111C 2598 Ant. pol. : VERTICAL
 Limit : FCC PART 15 B (3M)
 Env. / Ins. : 24°C/56% Engineer : Victory-Cao
 EUT : LCD TV M/N:LE43FHDF3300
 Power rating : AC 120V/60Hz
 Test Mode : Running "H" Pattern And 1KHz Playing
 VGA:1920*1080@60Hz

No.	Freq. (MHz)	Ant. Factor (dB/m)	Cable Loss (dB)	Reading (dBUV)	Emission Level (dBUV/m)	Limits (dBUV/m)	Margin (dB)	Remark
1	57.160	6.66	0.39	28.63	35.68	40.00	4.32	QP
2	74.350	7.30	0.54	27.60	35.44	40.00	4.56	QP
3	390.840	16.31	1.34	22.70	40.35	46.00	5.65	QP
4	522.760	18.37	1.60	22.19	42.16	46.00	3.84	QP
5	585.000	19.70	1.58	20.70	41.98	46.00	4.02	QP
6	670.200	20.80	1.90	18.30	41.00	46.00	5.00	QP

Remarks: 1. Emission Level= Antenna Factor + Cable Loss + Reading.
 2. The emission levels that are 20dB below the official limit are not reported.

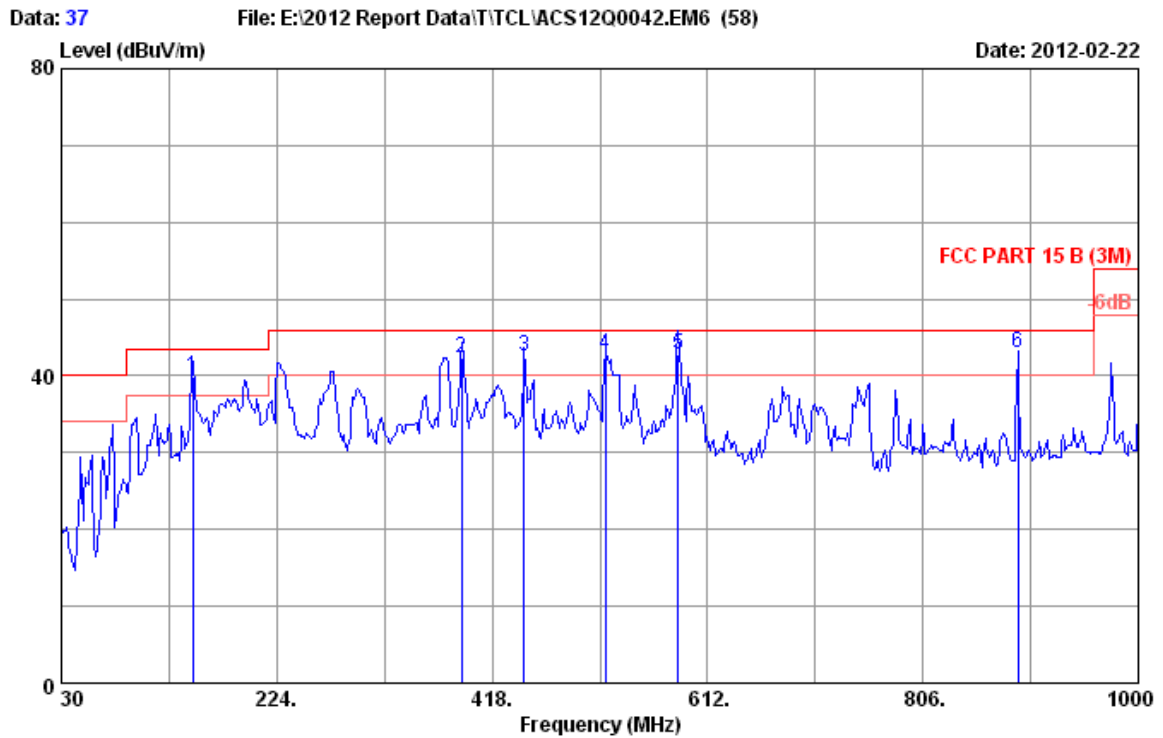

Site no. : 3m Chamber Data no. : 37
 Dis. / Ant. : 3m 2010 CBL6111C 2598 Ant. pol. : HORIZONTAL
 Limit : FCC PART 15 B (3M)
 Env. / Ins. : 24°C/56% Engineer : Victory-Cao
 EUT : LCD TV M/N:LE43FHDF3300
 Power rating : AC 120V/60Hz
 Test Mode : Running "H" Pattern And 1KHz Playing
 HDMI 1 :1920*1080@60Hz

No.	Freq. (MHz)	Ant. Factor (dB/m)	Cable Loss (dB)	Reading (dBUV)	Emission Level (dBUV/m)	Limits (dBUV/m)	Margin (dB)	Remark
1	148.340	11.72	0.80	27.33	39.85	43.50	3.65	QP
2	390.840	16.31	1.34	24.72	42.37	46.00	3.63	QP
3	447.100	17.06	1.50	24.10	42.66	46.00	3.34	QP
4	519.850	18.40	1.60	22.76	42.76	46.00	3.24	QP
5	585.810	19.72	1.57	21.52	42.81	46.00	3.19	QP
6	891.360	22.89	2.24	17.80	42.93	46.00	3.07	QP

Remarks: 1. Emission Level= Antenna Factor + Cable Loss + Reading.
 2. The emission levels that are 20dB below the official limit are not reported.

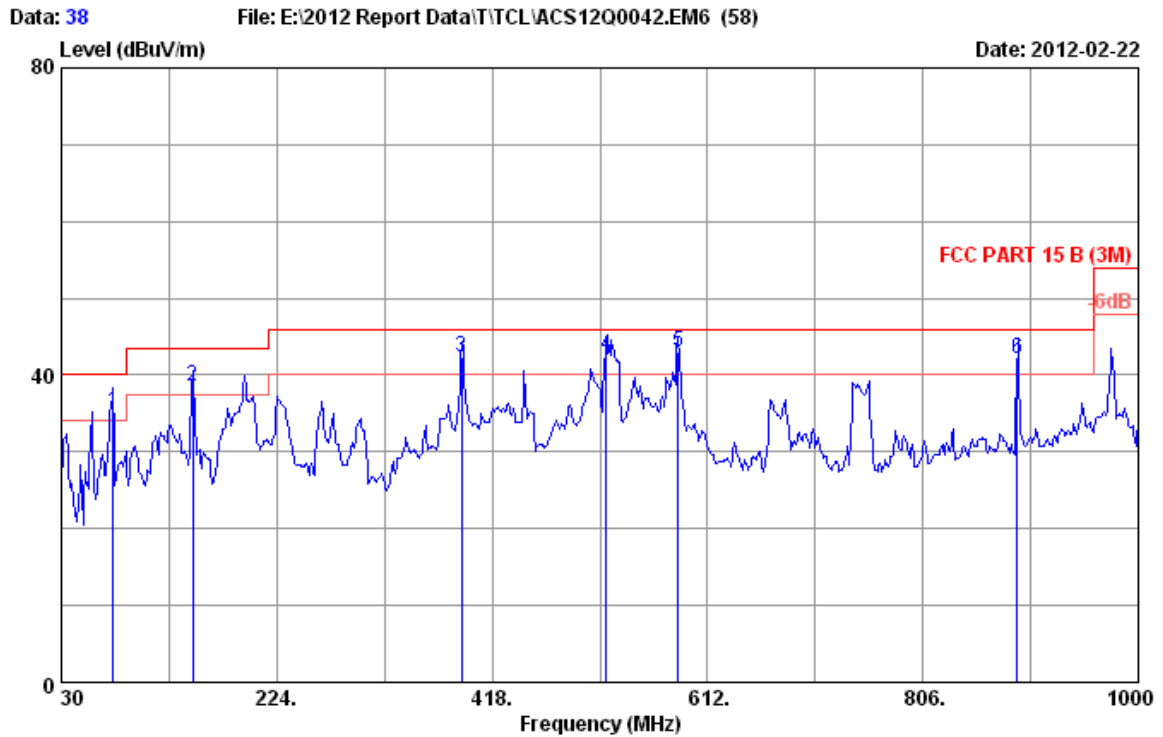

Site no. : 3m Chamber Data no. : 38
 Dis. / Ant. : 3m 2010 CBL6111C 2598 Ant. pol. : VERTICAL
 Limit : FCC PART 15 B (3M)
 Env. / Ins. : 24°C/56% Engineer : Victory-Cao
 EUT : LCD TV M/N:LE43FHDF3300
 Power rating : AC 120V/60Hz
 Test Mode : Running "H" Pattern And 1KHz Playing
 HDMI 1 : 1920*1080@60Hz

No.	Freq. (MHz)	Ant. Factor (dB/m)	Cable Loss (dB)	Reading (dBUV)	Emission Level (dBUV/m)	Limits (dBUV/m)	Margin (dB)	Remark
1	76.560	7.47	0.56	27.21	35.24	40.00	4.76	QP
2	148.340	11.72	0.80	25.99	38.51	43.50	4.99	QP
3	390.840	16.31	1.34	24.71	42.36	46.00	3.64	QP
4	520.820	18.39	1.60	22.66	42.65	46.00	3.35	QP
5	585.810	19.72	1.57	21.70	42.99	46.00	3.01	QP
6	891.000	22.89	2.24	16.90	42.03	46.00	3.97	QP

Remarks: 1. Emission Level= Antenna Factor + Cable Loss + Reading.
 2. The emission levels that are 20dB below the official limit are not reported.

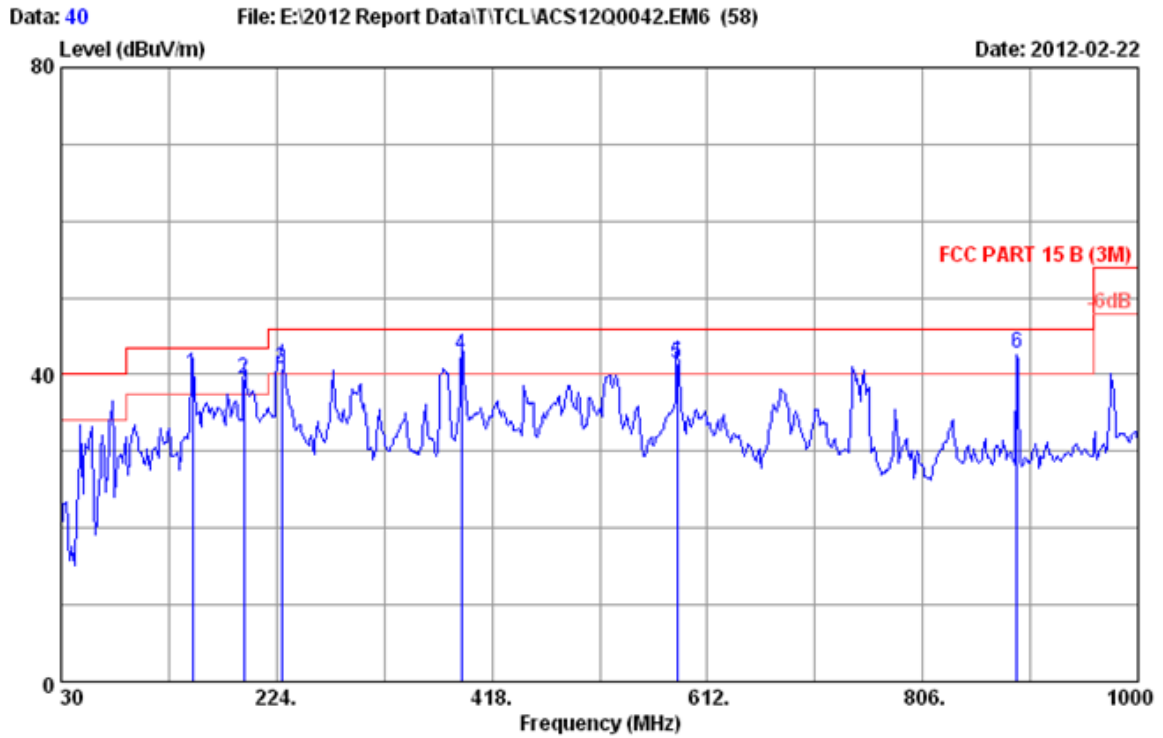

Site no. : 3m Chamber Data no. : 40
 Dis. / Ant. : 3m 2010 CBL6111C 2598 Ant. pol. : HORIZONTAL
 Limit : FCC PART 15 B (3M)
 Env. / Ins. : 24°C/56% Engineer : Victory-Cao
 EUT : LCD TV M/N:LE43FHDF3300
 Power rating : AC 120V/60Hz
 Test Mode : Running "H" Pattern And 1KHz Playing
 HDMI 2 :1920*1080@60Hz

No.	Freq. (MHz)	Ant. Factor (dB/m)	Cable Loss (dB)	Reading (dBuV)	Emission Level (dBuV/m)	Limits (dBuV/m)	Margin (dB)	Remark
1	148.340	11.72	0.80	27.54	40.06	43.50	3.44	QP
2	194.900	9.70	0.92	28.88	39.50	43.50	4.00	QP
3	228.850	10.92	1.10	28.81	40.83	46.00	5.17	QP
4	390.840	16.31	1.34	24.88	42.53	46.00	3.47	QP
5	584.840	19.70	1.58	20.07	41.35	46.00	4.65	QP
6	891.040	22.89	2.24	17.70	42.83	46.00	3.17	QP

Remarks: 1. Emission Level= Antenna Factor + Cable Loss + Reading.
 2. The emission levels that are 20dB below the official limit are not reported.

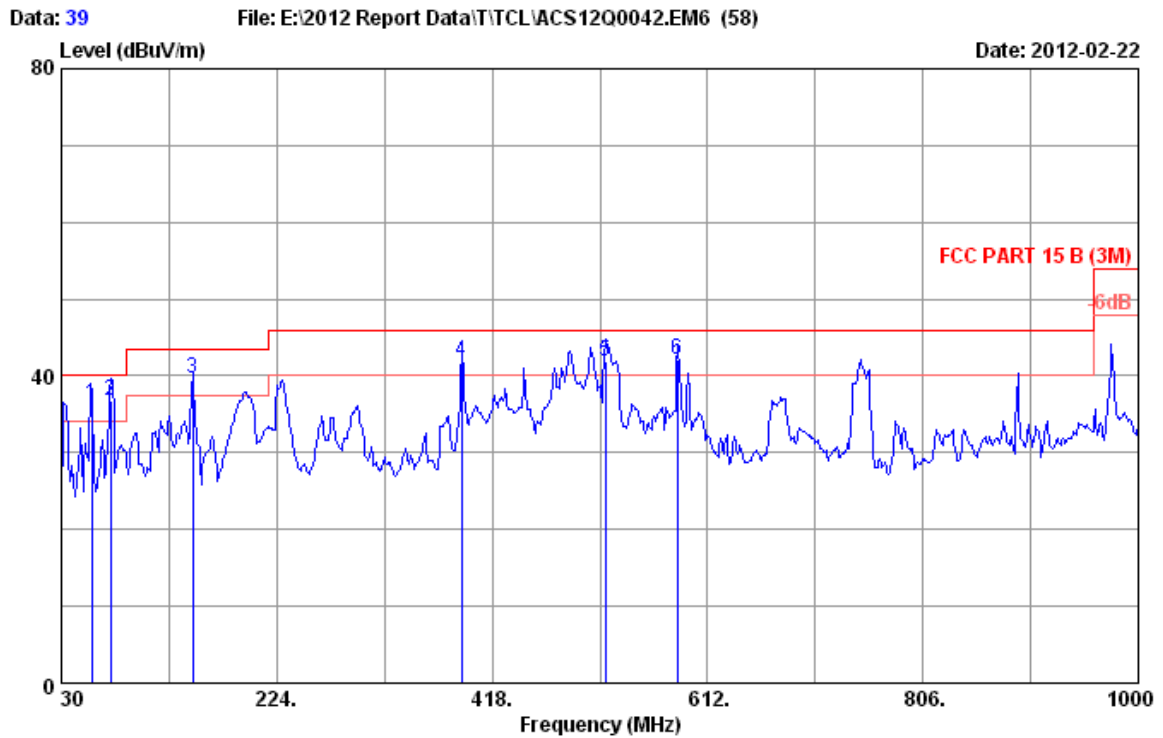

Site no. : 3m Chamber Data no. : 39
 Dis. / Ant. : 3m 2010 CBL6111C 2598 Ant. pol. : VERTICAL
 Limit : FCC PART 15 B (3M)
 Env. / Ins. : 24°C/56% Engineer : Victory-Cao
 EUT : LCD TV M/N:LE43FHDF3300
 Power rating : AC 120V/60Hz
 Test Mode : Running "H" Pattern And 1KHz Playing
 HDMI 2 :1920*1080@60Hz

No.	Freq. (MHz)	Ant. Factor (dB/m)	Cable Loss (dB)	Reading (dBuV)	Emission Level (dBuV/m)	Limits (dBuV/m)	Margin (dB)	Remark
1	57.160	6.66	0.39	29.36	36.41	40.00	3.59	QP
2	74.620	7.30	0.54	28.87	36.71	40.00	3.29	QP
3	148.340	11.72	0.80	27.03	39.55	43.50	3.95	QP
4	390.840	16.31	1.34	24.24	41.89	46.00	4.11	QP
5	519.850	18.40	1.60	21.87	41.87	46.00	4.13	QP
6	584.840	19.70	1.58	20.79	42.07	46.00	3.93	QP

Remarks: 1. Emission Level= Antenna Factor + Cable Loss + Reading.
 2. The emission levels that are 20dB below the official limit are not reported.

1GHz~2GHz

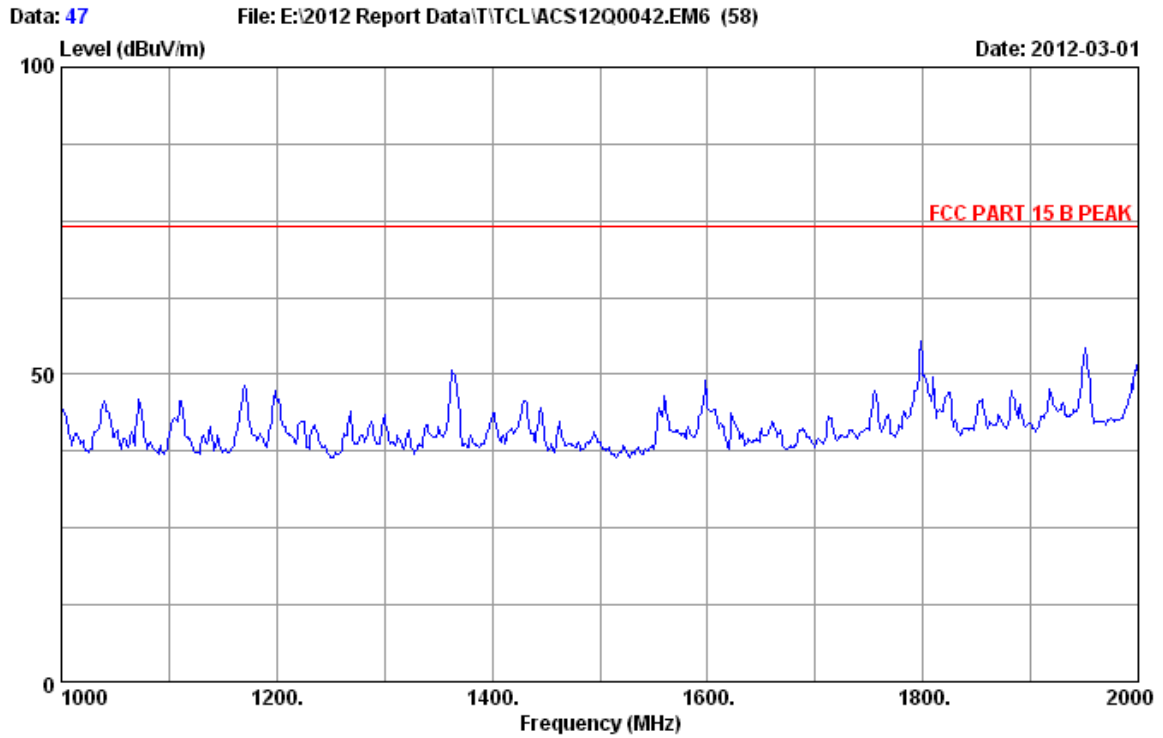

Site no. : 3m Chamber Data no. : 47
Dis. / Ant. : 3m 2011 3115 9607-4877 Ant. pol. : HORIZONTAL
Limit : FCC PART 15 B PEAK
Env. / Ins. : 24°C/56% Engineer : Victory-Cao
EUT : LCD TV M/N:LE43FHDF3300
Power Rating : AC 120V/60Hz
Test Mode : Running "H" Pattern And 1KHz Playing
VGA:1920*1080@60Hz

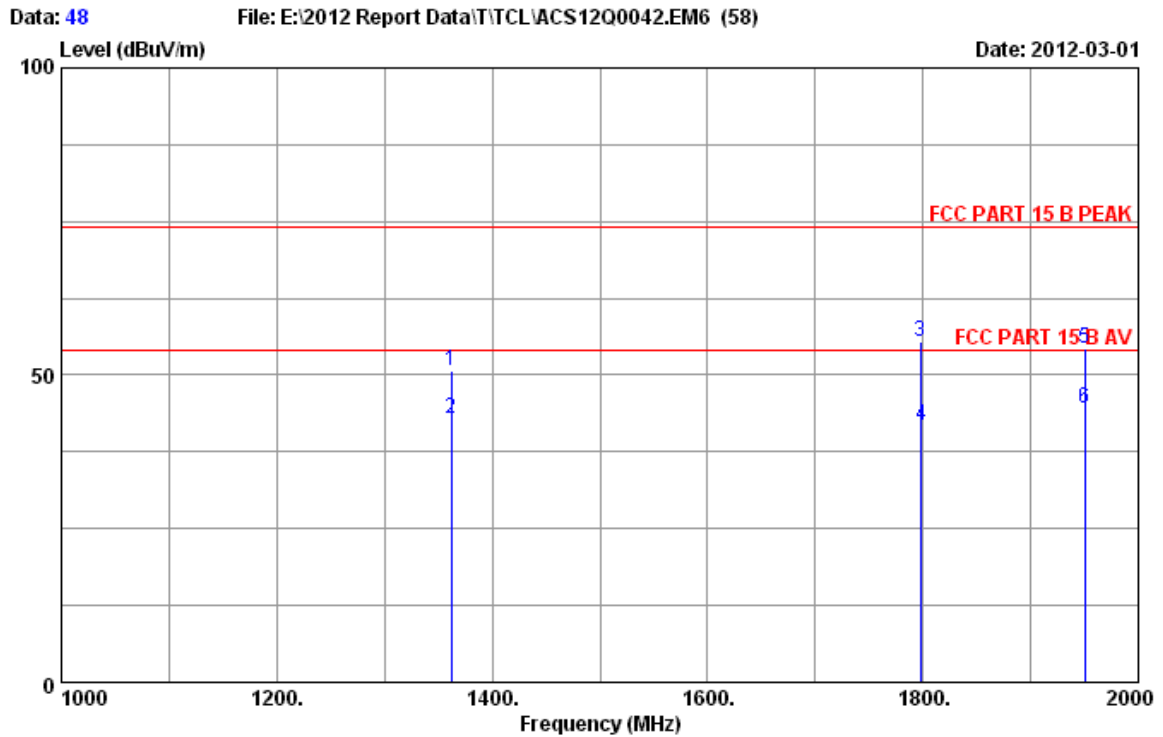

Site no. : 3m Chamber Data no. : 48
 Dis. / Ant. : 3m 2011 3115 9607-4877 Ant. pol. : HORIZONTAL
 Limit : FCC PART 15 B PEAK
 Env. / Ins. : 24°C/56% Engineer : Victory-Cao
 EUT : LCD TV M/N:LE43FHDF3300
 Power Rating : AC 120V/60Hz
 Test Mode : Running "H" Pattern And 1KHz Playing
 VGA:1920*1080@60Hz

No.	Freq. (MHz)	Ant. Factor (dB/m)	Cable Loss (dB)	AMP factor (dBuV)	Reading (dBuV/m)	Emission Level (dBuV/m)	Limits (dB)	Margin (dB)	Remark
1	1362.000	24.94	1.10	35.12	59.73	50.65	74.00	23.35	Peak
2	1362.200	24.94	1.10	35.12	51.99	42.91	54.00	11.09	Average
3	1798.000	26.74	1.75	34.76	61.75	55.48	74.00	18.52	Peak
4	1798.500	26.74	1.75	34.76	48.00	41.73	54.00	12.27	Average
5	1950.000	27.31	1.99	34.64	59.60	54.26	74.00	19.74	Peak
6	1950.500	27.31	1.99	34.64	50.00	44.66	54.00	9.34	Average

Remarks: 1. Emission Level= Antenna Factor + Cable Loss + Reading - Amp Factor
 2. The emission levels that are 20dB below the official limit are not reported.

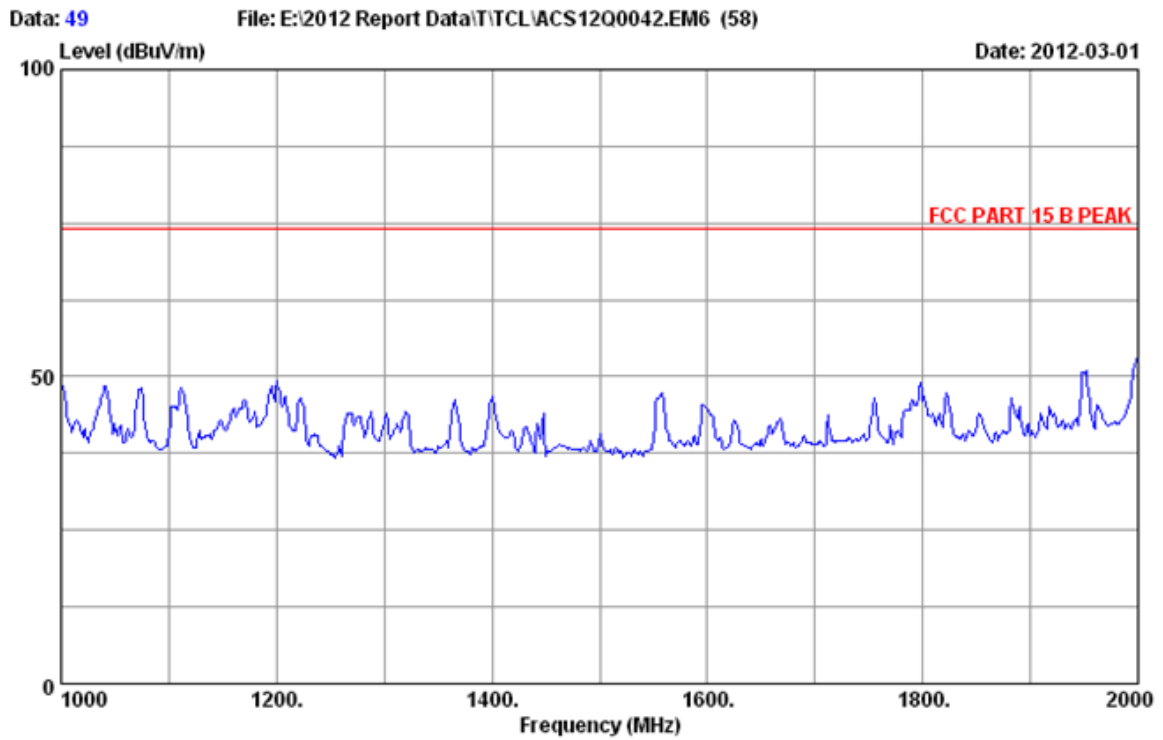

Site no. : 3m Chamber Data no. : 49
Dis. / Ant. : 3m 2011 3115 9607-4877 Ant. pol. : VERTICAL
Limit : FCC PART 15 B PEAK
Env. / Ins. : 24°C/56% Engineer : Victory-Cao
EUT : LCD TV M/N:LE43FHDF3300
Power Rating : AC 120V/60Hz
Test Mode : Running "H" Pattern And 1KHz Playing
VGA:1920*1080@60Hz

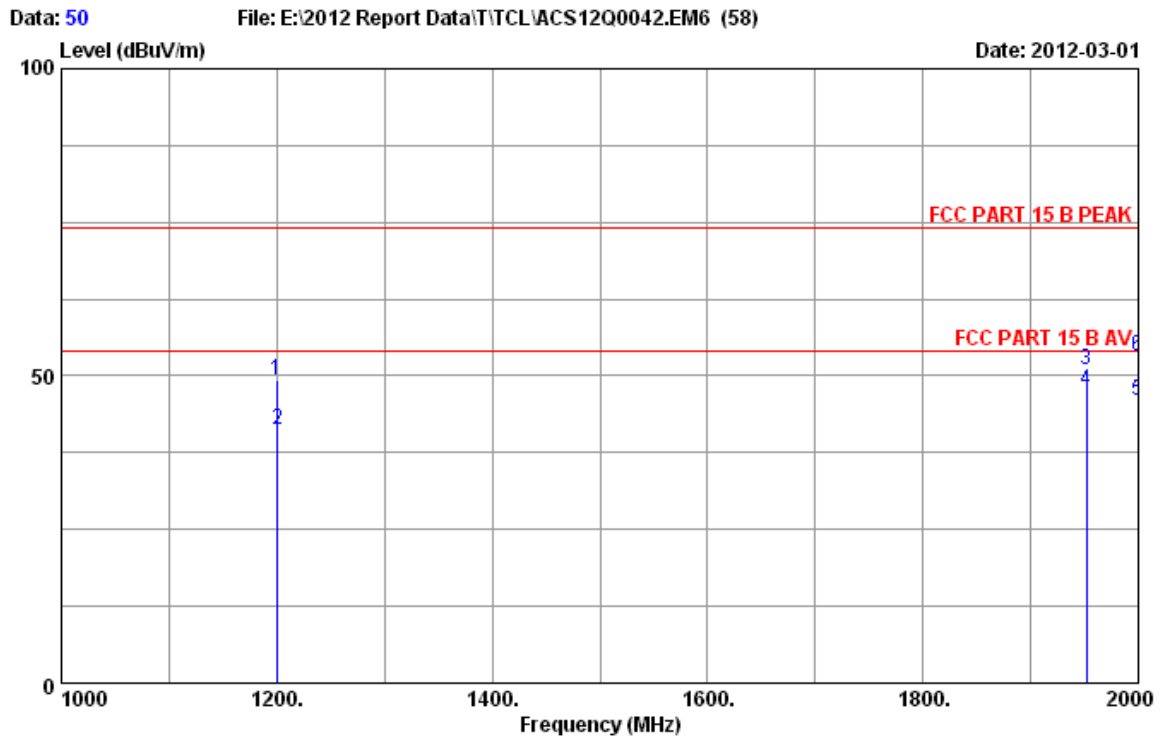

Site no. : 3m Chamber Data no. : 50
 Dis. / Ant. : 3m 2011 3115 9607-4877 Ant. pol. : VERTICAL
 Limit : FCC PART 15 B PEAK
 Env. / Ins. : 24°C/56% Engineer : Victory-Cao
 EUT : LCD TV M/N:LE43FHDF3300
 Power Rating : AC 120V/60Hz
 Test Mode : Running "H" Pattern And 1KHz Playing
 VGA:1920*1080@60Hz

No.	Freq. (MHz)	Ant. Factor (dB/m)	Cable Loss (dB)	AMP factor (dBuV)	Reading (dBuV/m)	Emission Level (dBuV/m)	Limits (dB)	Margin (dB)	Remark
1	1200.000	24.19	0.86	35.24	59.61	49.42	74.00	24.58	Peak
2	1200.600	24.19	0.86	35.24	51.50	41.31	54.00	12.69	Average
3	1952.000	27.31	1.99	34.64	56.36	51.02	74.00	22.98	Peak
4	1952.300	27.31	1.99	34.64	53.00	47.66	54.00	6.34	Average
5	1999.500	27.50	2.05	34.60	51.00	45.95	54.00	8.05	Average
6	2000.000	27.50	2.05	34.60	58.32	53.27	74.00	20.73	Peak

Remarks: 1. Emission Level= Antenna Factor + Cable Loss + Reading - Amp Factor
 2. The emission levels that are 20dB below the official limit are not reported.

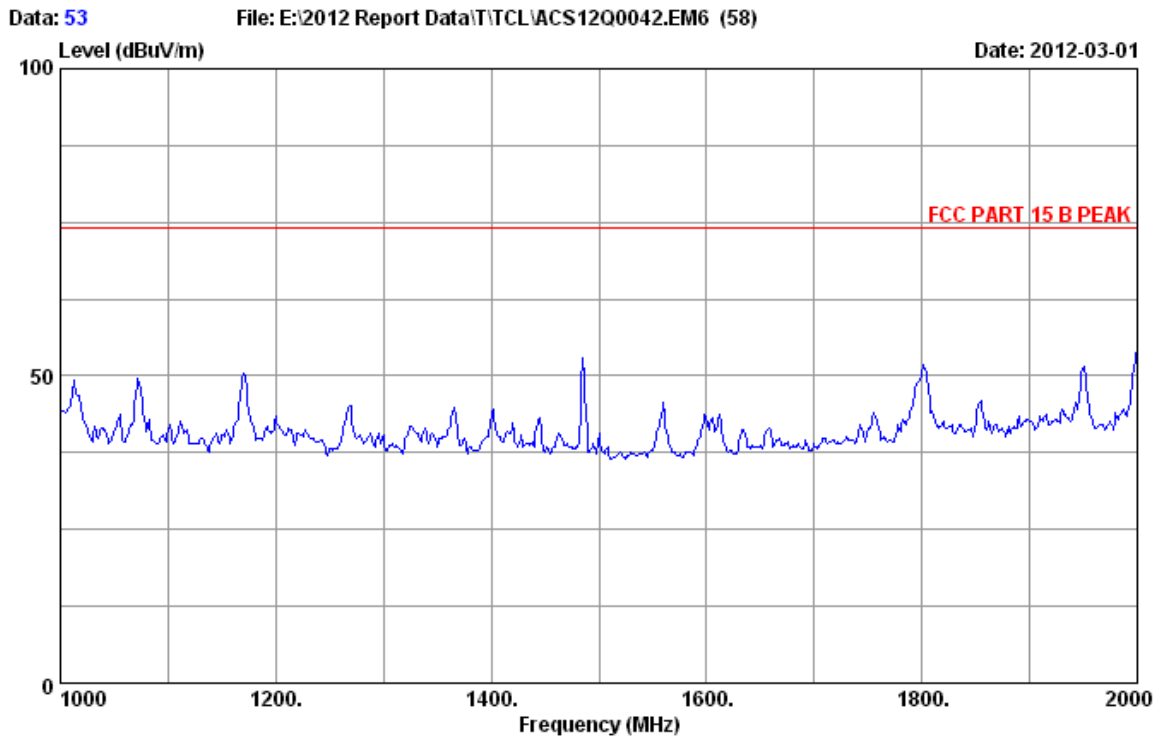

Site no. : 3m Chamber Data no. : 53
Dis. / Ant. : 3m 2011 3115 9607-4877 Ant. pol. : HORIZONTAL
Limit : FCC PART 15 B PEAK
Env. / Ins. : 24°C/56% Engineer : Victory-Cao
EUT : LCD TV M/N:LE43FHDF3300
Power Rating : AC 120V/60Hz
Test Mode : Running "H" Pattern And 1KHz Playing
HDMI 1:1920*1080@60Hz

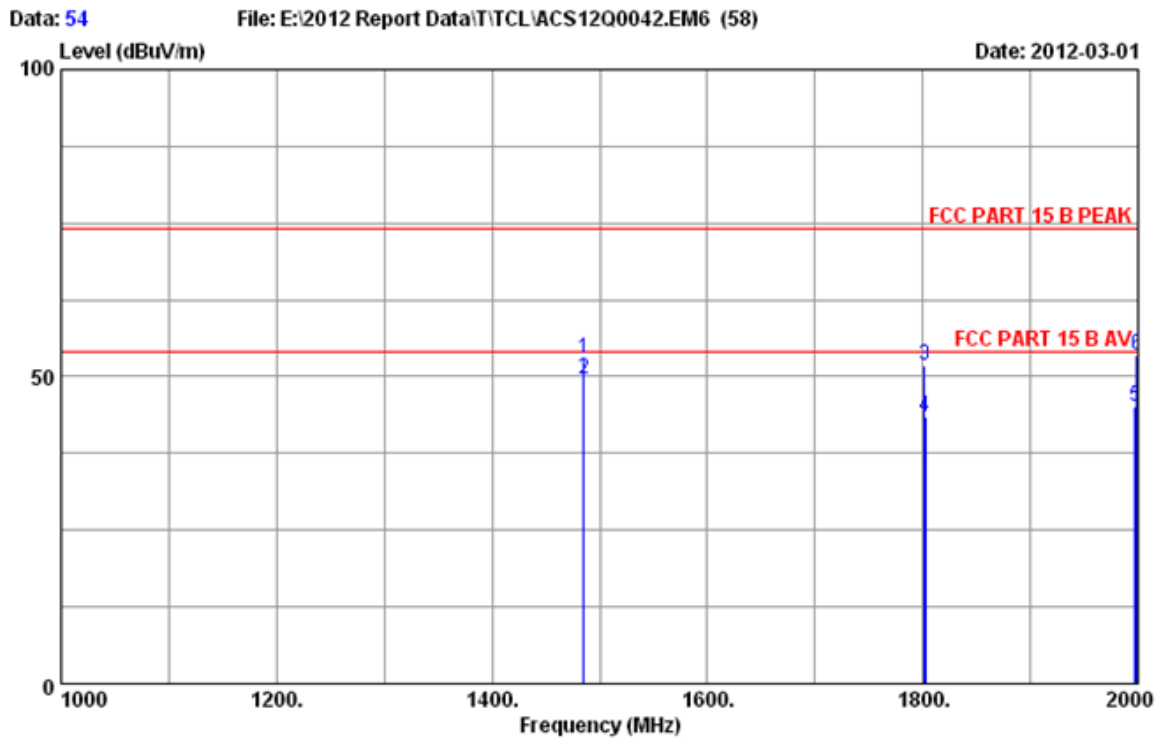

Site no. : 3m Chamber Data no. : 54
 Dis. / Ant. : 3m 2011 3115 9607-4877 Ant. pol. : HORIZONTAL
 Limit : FCC PART 15 B PEAK
 Env. / Ins. : 24°C/56% Engineer : Victory-Cao
 EUT : LCD TV M/N:LE43FHDF3300
 Power Rating : AC 120V/60Hz
 Test Mode : Running "H" Pattern And 1KHz Playing
 HDMI 1:1920*1080@60Hz

No.	Freq. (MHz)	Ant. Factor (dB/m)	Cable Loss (dB)	AMP factor (dBuV)	Reading (dBuV/m)	Emission Level (dBuV/m)	Limits (dB)	Margin (dB)	Remark
1	1485.000	25.60	1.28	35.02	61.03	52.89	74.00	21.11	Peak
2	1485.600	25.60	1.28	35.02	57.60	49.46	54.00	4.54	Average
3	1802.000	26.74	1.75	34.76	58.07	51.80	74.00	22.20	Peak
4	1802.100	26.74	1.75	34.76	49.60	43.33	54.00	10.67	Average
5	1997.300	27.50	2.05	34.60	50.20	45.15	54.00	8.85	Average
6	1999.000	27.50	2.05	34.60	58.46	53.41	74.00	20.59	Peak

Remarks: 1. Emission Level= Antenna Factor + Cable Loss + Reading - Amp Factor
 2. The emission levels that are 20dB below the official limit are not reported.

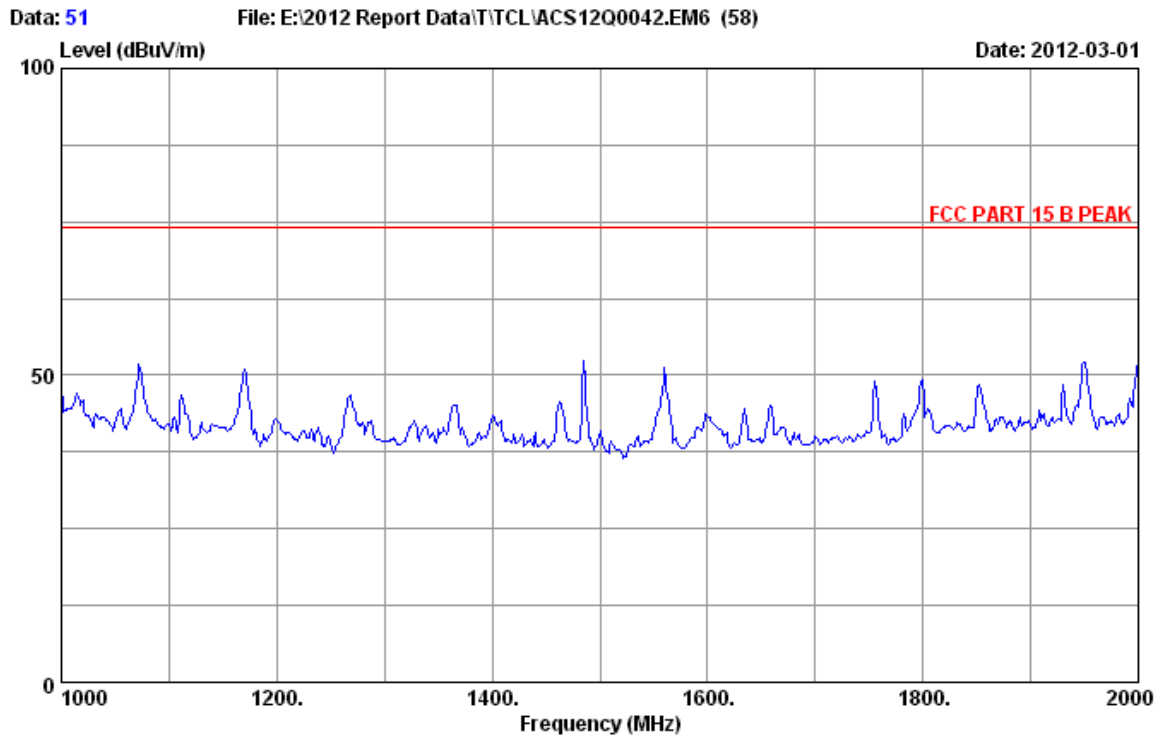

Site no. : 3m Chamber Data no. : 51
Dis. / Ant. : 3m 2011 3115 9607-4877 Ant. pol. : VERTICAL
Limit : FCC PART 15 B PEAK
Env. / Ins. : 24°C/56% Engineer : Victory-Cao
EUT : LCD TV M/N:LE43FHDF3300
Power Rating : AC 120V/60Hz
Test Mode : Running "H" Pattern And 1KHz Playing
HDMI 1:1920*1080@60Hz

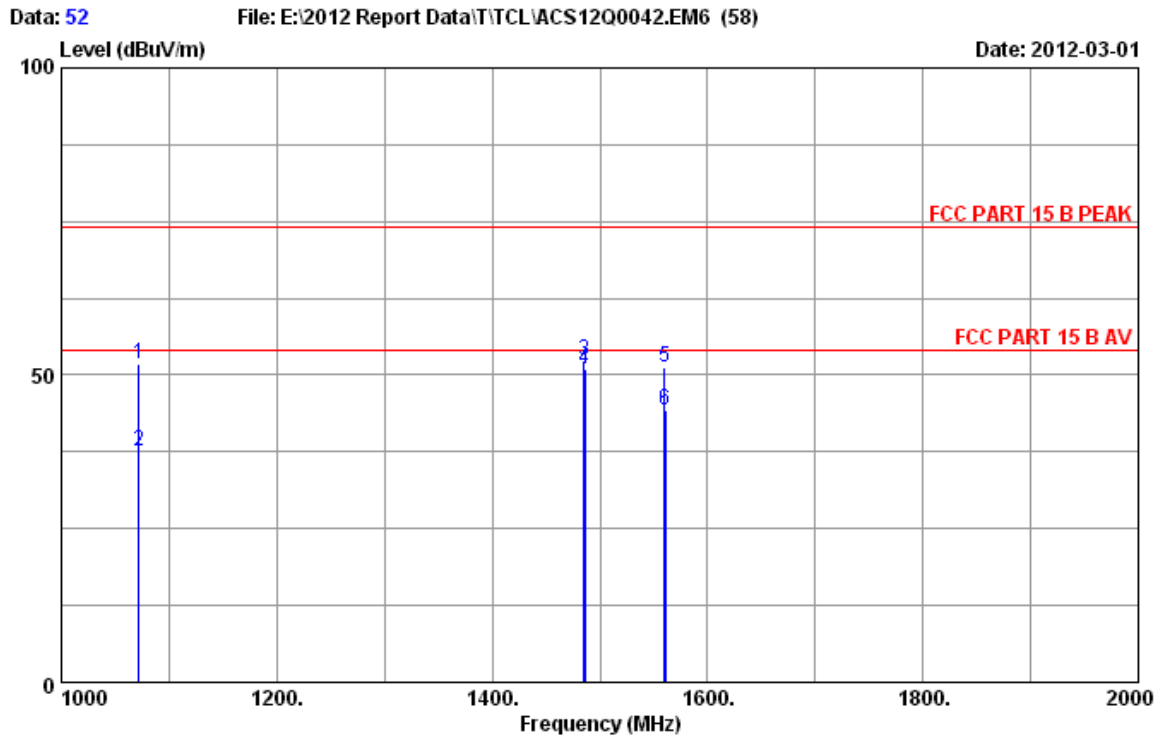

Site no. : 3m Chamber Data no. : 52
 Dis. / Ant. : 3m 2011 3115 9607-4877 Ant. pol. : VERTICAL
 Limit : FCC PART 15 B PEAK
 Env. / Ins. : 24°C/56% Engineer : Victory-Cao
 EUT : LCD TV M/N:LE43FHDF3300
 Power Rating : AC 120V/60Hz
 Test Mode : Running "H" Pattern And 1KHz Playing
 HDMI 1:1920*1080@60Hz

No.	Freq. (MHz)	Ant. Factor (dB/m)	Cable Loss (dB)	AMP factor (dBuV)	Reading (dBuV/m)	Emission Level (dBuV/m)	Limits (dB)	Margin (dB)	Remark
1	1072.000	23.53	0.68	35.34	63.00	51.87	74.00	22.13	Peak
2	1072.300	23.53	0.68	35.34	48.60	37.47	54.00	16.53	Average
3	1485.000	25.60	1.28	35.02	60.58	52.44	74.00	21.56	Peak
4	1485.800	25.60	1.28	35.02	59.00	50.86	54.00	3.14	Average
5	1560.000	25.85	1.39	34.96	58.97	51.25	74.00	22.75	Peak
6	1560.800	25.85	1.39	34.96	52.01	44.29	54.00	9.71	Average

Remarks: 1. Emission Level= Antenna Factor + Cable Loss + Reading - Amp Factor
 2. The emission levels that are 20dB below the official limit are not reported.

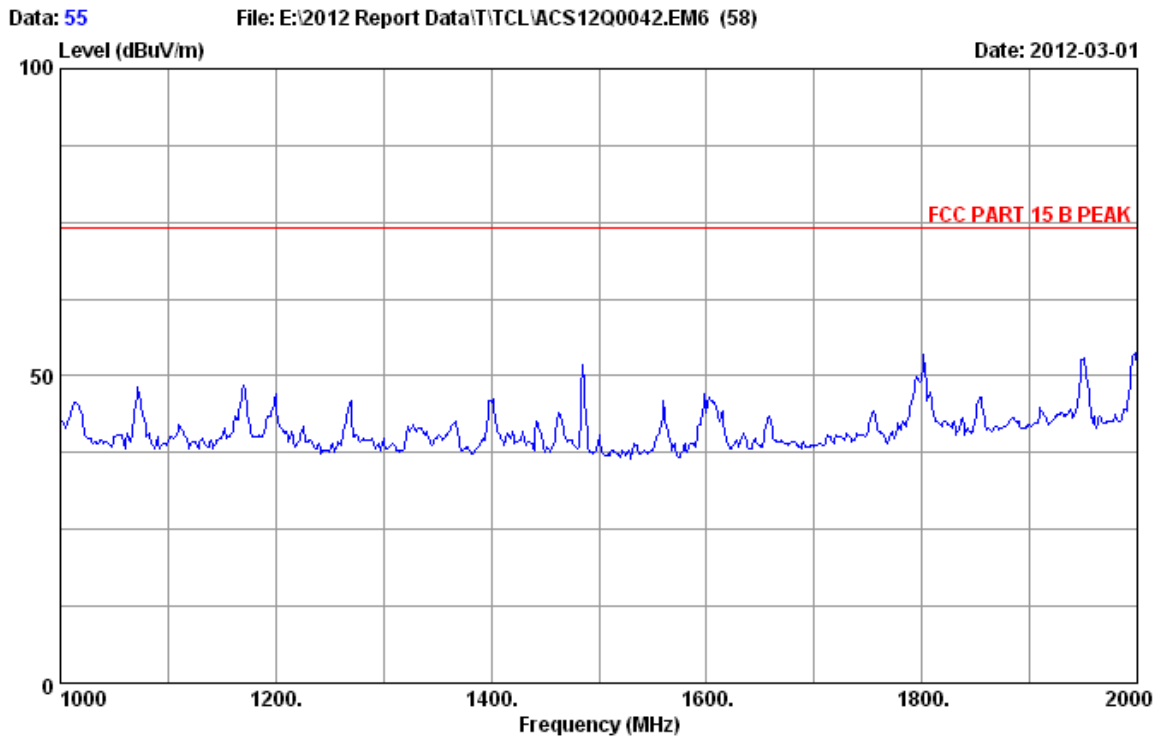

Site no. : 3m Chamber Data no. : 55
Dis. / Ant. : 3m 2011 3115 9607-4877 Ant. pol. : HORIZONTAL
Limit : FCC PART 15 B PEAK
Env. / Ins. : 24°C/56% Engineer : Victory-Cao
EUT : LCD TV M/N:LE43FHDF3300
Power Rating : AC 120V/60Hz
Test Mode : Running "H" Pattern And 1KHz Playing
HDMI 2:1920*1080@60Hz

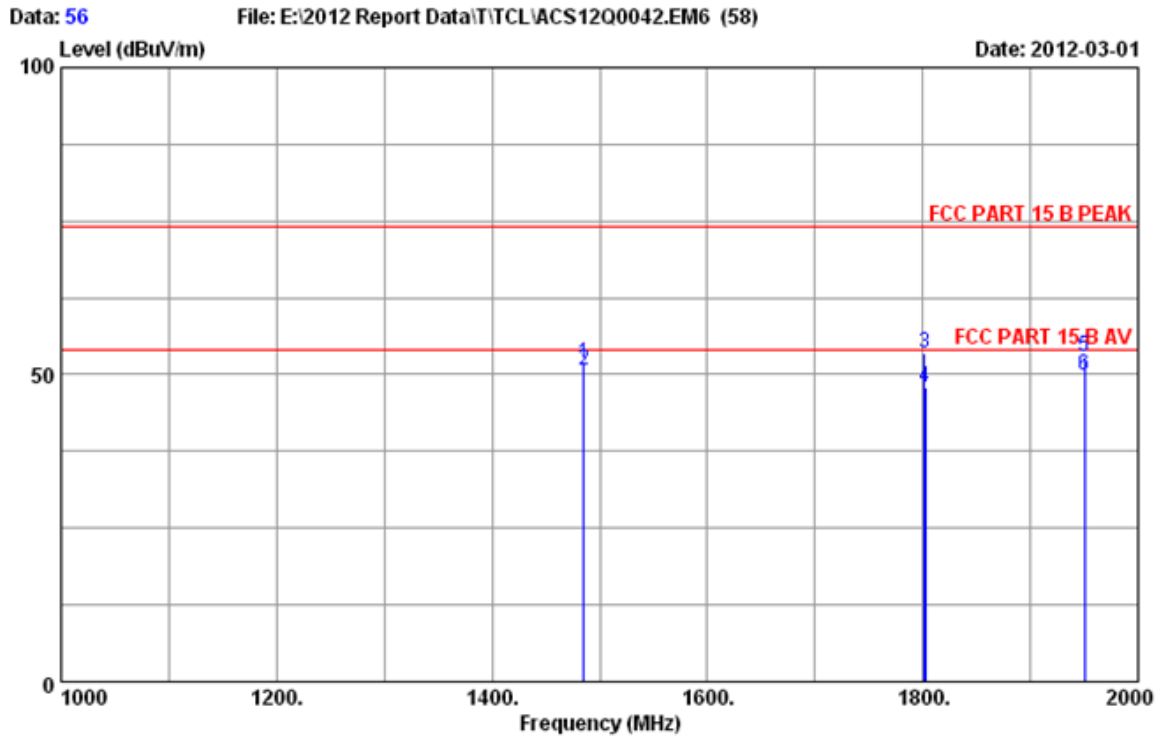

Site no. : 3m Chamber Data no. : 56
 Dis. / Ant. : 3m 2011 3115 9607-4877 Ant. pol. : HORIZONTAL
 Limit : FCC PART 15 B PEAK
 Env. / Ins. : 24°C/56% Engineer : Victory-Cao
 EUT : LCD TV M/N:LE43FHDF3300
 Power Rating : AC 120V/60Hz
 Test Mode : Running "H" Pattern And 1KHz Playing
 HDMI 2:1920*1080@60Hz

No.	Freq. (MHz)	Ant. Factor (dB/m)	Cable Loss (dB)	AMP factor (dBuV)	Reading (dBuV/m)	Emission Level (dBuV/m)	Limits (dB)	Margin (dB)	Remark
1	1485.000	25.60	1.28	35.02	60.09	51.95	74.00	22.05	Peak
2	1485.300	25.60	1.28	35.02	58.90	50.76	54.00	3.24	Average
3	1802.000	26.74	1.75	34.76	59.76	53.49	74.00	20.51	Peak
4	1802.400	26.74	1.75	34.76	54.10	47.83	54.00	6.17	Average
5	1950.000	27.31	1.99	34.64	58.29	52.95	74.00	21.05	Peak
6	1950.300	27.31	1.99	34.64	55.20	49.86	54.00	4.14	Average

Remarks: 1. Emission Level= Antenna Factor + Cable Loss + Reading - Amp Factor
 2. The emission levels that are 20dB below the official limit are not reported.

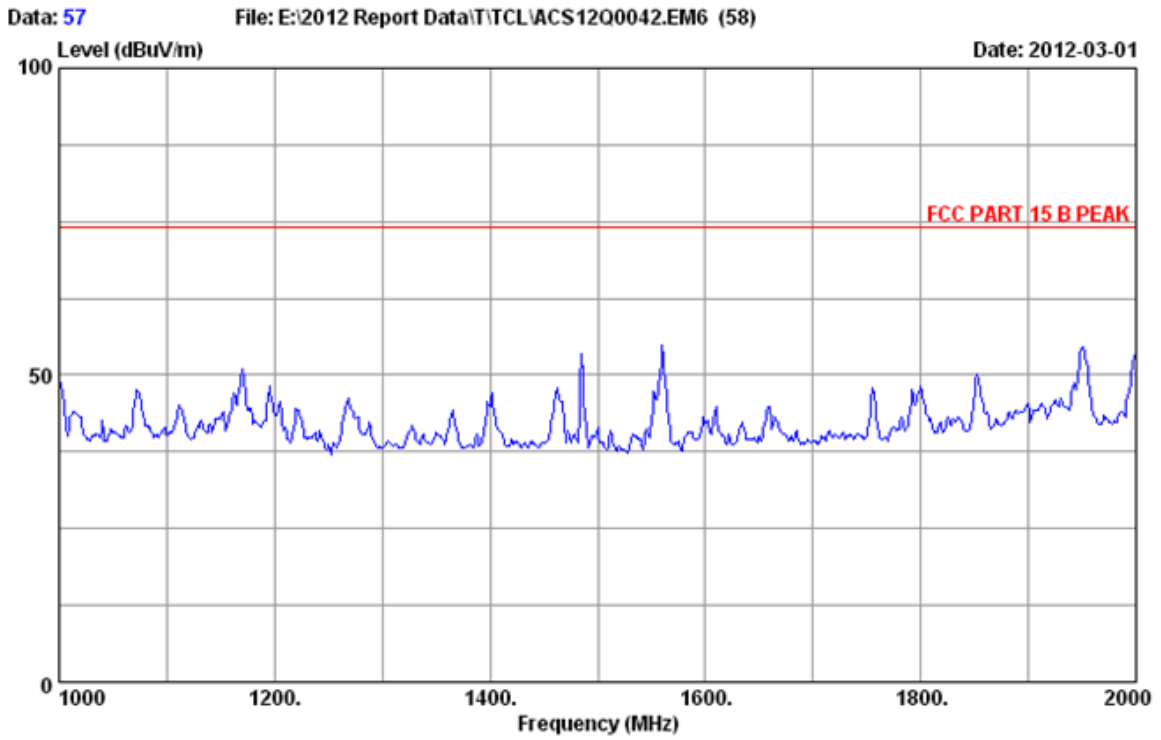

Site no. : 3m Chamber Data no. : 57
Dis. / Ant. : 3m 2011 3115 9607-4877 Ant. pol. : VERTICAL
Limit : FCC PART 15 B PEAK
Env. / Ins. : 24°C/56% Engineer : Victory-Cao
EUT : LCD TV M/N:LE43FHDF3300
Power Rating : AC 120V/60Hz
Test Mode : Running "H" Pattern And 1KHz Playing
HDMI 2:1920*1080@60Hz

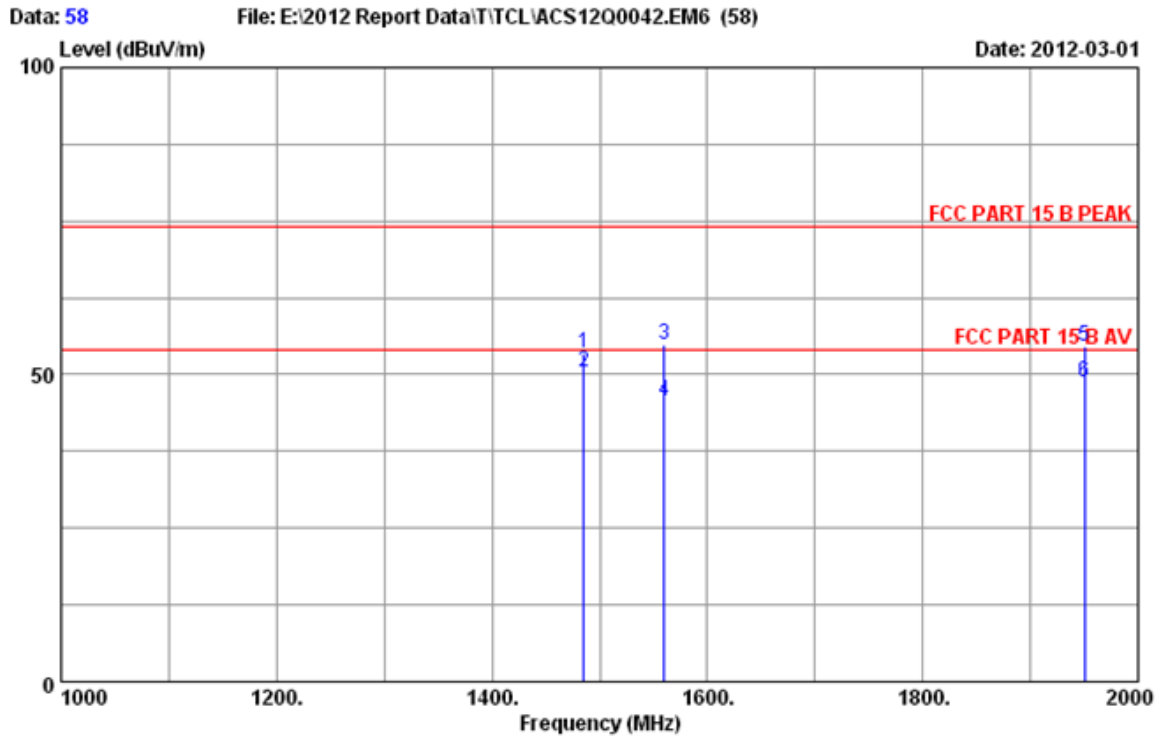

Site no. : 3m Chamber Data no. : 58
 Dis. / Ant. : 3m 2011 3115 9607-4877 Ant. pol. : VERTICAL
 Limit : FCC PART 15 B PEAK
 Env. / Ins. : 24°C/56% Engineer : Victory-Cao
 EUT : LCD TV M/N:LE43FHDF3300
 Power Rating : AC 120V/60Hz
 Test Mode : Running "H" Pattern And 1KHz Playing
 HDMI 2:1920*1080@60Hz

No.	Freq. (MHz)	Ant. Factor (dB/m)	Cable Loss (dB)	AMP factor (dBuV)	Reading (dBuV/m)	Emission Level (dBuV/m)	Limits (dB)	Margin (dB)	Remark
1	1485.000	25.60	1.28	35.02	61.71	53.57	74.00	20.43	Peak
2	1485.300	25.60	1.28	35.02	58.70	50.56	54.00	3.44	Average
3	1560.000	25.85	1.39	34.96	62.49	54.77	74.00	19.23	Peak
4	1560.200	25.85	1.39	34.96	53.31	45.59	54.00	8.41	Average
5	1950.000	27.31	1.99	34.64	59.89	54.55	74.00	19.45	Peak
6	1950.300	27.31	1.99	34.64	54.20	48.86	54.00	5.14	Average

Remarks: 1. Emission Level= Antenna Factor + Cable Loss + Reading - Amp Factor
 2. The emission levels that are 20dB below the official limit are not reported.

5. DEVIATION TO TEST SPECIFICATIONS

[NONE]