



APPLICATION OF CERTIFICATION
For

TTE Technology Inc.

LED TV

Brand Name	Model Number
TCL	LE32HDD20

FCC ID: W8ULE32HDD20

Prepared for : TTE Technology Inc.
255 Graphite Drive, Corona, CA 92881

Prepared By: Audix Technology (Shenzhen) Co., Ltd.
No. 6, Ke Feng Rd., 52 Block,
Shenzhen Science & Industrial Park,
Nantou, Shenzhen, Guangdong, China

Tel: (0755) 26639496
Fax: (0755) 26632877

Report Number : ACS- F11039
Date of Test : Jan.14~20, 2011
Date of Report : Feb.22, 2011

TABLE OF CONTENTS

Description	Page
Test Report Declaration	
1. SUMMARY OF STANDARDS AND RESULTS	1-3
1.1. Description of Standards and Results	1-3
2. GENERAL INFORMATION.....	2-3
2.1. Description of Device (EUT).....	2-3
2.2. Tested Supporting System Details.....	2-3
2.3. Block diagram of connection between the EUT and simulators.....	2-3
2.4. Test Facility	2-3
2.5. Measurement Uncertainty (95% confidence levels, k=2).....	2-3
3. POWER LINE CONDUCTED EMISSION TEST	3-3
3.1. Test Equipment.....	3-3
3.2. Block Diagram of Test Setup.....	3-3
3.3. Power Line Conducted Emission Test Limits	3-3
3.4. Configuration of EUT on Test.....	3-3
3.5. Operating Condition of EUT	3-3
3.6. Test Procedure	3-3
3.7. Conducted Disturbance at Mains Terminals Test Results	3-3
4. RADIATED EMISSION TEST.....	4-3
4.1. Test Equipment.....	4-3
4.2. Block Diagram of Test Setup.....	4-3
4.3. Radiated Emission Limit	4-3
4.4. EUT Configuration on Test	4-3
4.5. Operating Condition of EUT	4-3
4.6. Test Procedure	4-3
4.7. Radiated Disturbance Test Results	4-3
5. PHOTOGRAPH	5-3
5.1. Photos of Power Line Conducted Emission Test.....	5-3
5.2. Photos of Radiated Emission Test (In Anechoic Chamber)	5-3
6. PHOTOS OF THE EUT	6-3

TEST REPORT CERTIFICATION

Applicant : TTE Technology Inc.
 Manufacturer : TCL King Electrical Appliances (Huizhou) Co., Ltd.
 EUT Description : LED TV
 FCC ID : W8ULE32HDD20

(A) MODEL NO. & Brand Name	Brand Name	Model Number
:	TCL	LE32HDD20

(B) SERIAL NO. : N/A

(C) TEST VOLTAGE : AC 120V/60Hz

Measurement Standard Used:
 FCC Rules and Regulations Part 15 Subpart B Class B 2008, ANSI C63.4-2003
 ICES-003 Issue 4 February 2004.

The device described above is tested by AUDIX TECHNOLOGY (SHENZHEN) CO., LTD. to determine the maximum emission levels emanating from the device. The maximum emission levels are compared to the FCC Part 15 Subpart B Class B limits both conducted and radiated emissions. The test results are contained in this test report and AUDIX TECHNOLOGY (SHENZHEN) CO., LTD. is assumed of full responsibility for the accuracy and completeness of these tests.

After the test, our opinion is that EUT compliance with the requirement of the above standards.

This report applies to above tested sample only. This report shall not be reproduced in parts without written approval of AUDIX TECHNOLOGY (SHENZHEN) CO., LTD.

Date of Test : Jan.14~20, 2011 Report of date: Feb.22, 2011

Prepared by : Vicky Huang Reviewer by : Richzy Zhong
 Vicky Hunag / Assistant Richzy Zhong / Assistant Manager



Approved & Authorized Signer : Ken Lu / Manager

1. SUMMARY OF STANDARDS AND RESULTS

1.1. Description of Standards and Results

The EUT have been tested according to the applicable standards as referenced below.

EMISSION			
Description of Test Item	Standard	Results	Remarks
Power Line Conducted Emission Test	FCC Part 15: 2008 ANSI C63.4: 2003	PASS	Meets Class B Limit Minimum passing margin is 4.09dB at 1.792MHz
Radiated Emission Test	FCC Part 15: 2008 ANSI C63.4: 2003	PASS	Meets Class B Limit Minimum passing margin is 3.00dB at 891.360MHz

2. GENERAL INFORMATION

2.1. Description of Device (EUT)

Description : LED TV

Model Number :

Brand Name	Model Number
TCL	LE32HDD20

FCC ID : W8ULE32HDD20

Applicant : TTE Technology Inc.
255 Graphite Drive, Corona, CA 92881

Manufacturer : TCL King Electrical Appliances (Huizhou) Co., Ltd.
Section 19, Zhongkai Development Zone for New & High-Level
Tech Industries, Huizhou, Guangdong Province, China, 516006.

FREQUENCIES USED AND GENERATED WITHIN DEVICE		
X54M1	45-OSC54M-0Y1CR	54MHz
LVDS CLOCK	80MHZ	
IF	45.75MHz	
DC-DC	U302->385KHz	U303->1MHz
DDR	440MHz	
AMP	384KHz	

Power Cord : Unshielded, Detachable, 1.5m

Date of Test : Jan.14~20, 2011

Date of Receipt : Jan.13, 2011

Sample Type : Prototype production

2.2. Tested Supporting System Details

	Description	ACS No.	Manufacturer	Model	Serial Number	Approved type
1	PC	Test PC P	DELL	Studio 540	124XK2X	<input checked="" type="checkbox"/> FCC DoC <input checked="" type="checkbox"/> BSMI ID:R33002
		Power Cord: Unshielded, Detachable, 1.8m Display Card: HD3450 (DVI+VGA+HDMI)				
2	Color TV	ACS-EMC-TV01T	TCL	1419A	N/A	<input type="checkbox"/> FCC ID <input type="checkbox"/> BSMI ID
3	Color TV	ACS-EMC-TV02T	TCL	22HR5434	N/A	<input type="checkbox"/> FCC ID <input type="checkbox"/> BSMI ID
4	USB Mouse	ACS-EMC-M02R	DELL	M056UO	512024264	<input checked="" type="checkbox"/> FCC DoC <input checked="" type="checkbox"/> BSMI ID: R41108
		Data Cable: shielded, Undetachable, 1.8m				
5	Printer	ACS-EMC-PT04	HP	C9079A	N/A	<input checked="" type="checkbox"/> FCC DoC <input checked="" type="checkbox"/> BSMI ID: R33001
		USB Cable: Shielded, Detachable, 1.8m Power Cord: Unshielded, Detachable, 1.8m DC Cable: Unshielded, Undetachable, 0.95m				
6	USB Keyboard	ACS-EMC- K02R	DELL	SK-8115	CN-ORH656-65 890-686-007J	<input checked="" type="checkbox"/> FCC DoC <input checked="" type="checkbox"/> BSMI ID: T3A002
		Data Cable: shielded, Undetachable, 2.0m				
7	Headphone	ACS-EMC-EP01	OVANN	OV880V	-	<input type="checkbox"/> FCC DoC <input type="checkbox"/> BSMI ID
		Cable: shielded, Detachable, 4.0m				
8	iPod	ACS-EMC-IP01	APPLE	A1199	YM706MLDVQ 5	<input checked="" type="checkbox"/> FCC DoC <input checked="" type="checkbox"/> BSMI ID: R33057
		Data Cable: Shielded, Detachable, 1.0m				
9	HDD	ACS-EMC-HDD01	Terasys	F12-UF	A0100215-53900 31	<input checked="" type="checkbox"/> FCC DoC <input checked="" type="checkbox"/> BSMI ID:
		USB Cable: Shielded, Detachable, 1.8m				
10	Dummy Load (10KΩ & 75Ω)	L+R+V Cable: Unshielded, Detachable, 1.2m Pb/Pr/Y Cable: Unshielded, Detachable, 1.2m Coaxial Cable: Unshielded, Detachable, 1.2m				
11	SG #1	-	Philips	PM5418	-	<input type="checkbox"/> FCC ID <input type="checkbox"/> BSMI ID
12	SG #2	-	R & S	DVG & SFQ	-	<input type="checkbox"/> FCC ID <input type="checkbox"/> BSMI ID

2.3. Block diagram of connection between the EUT and simulators

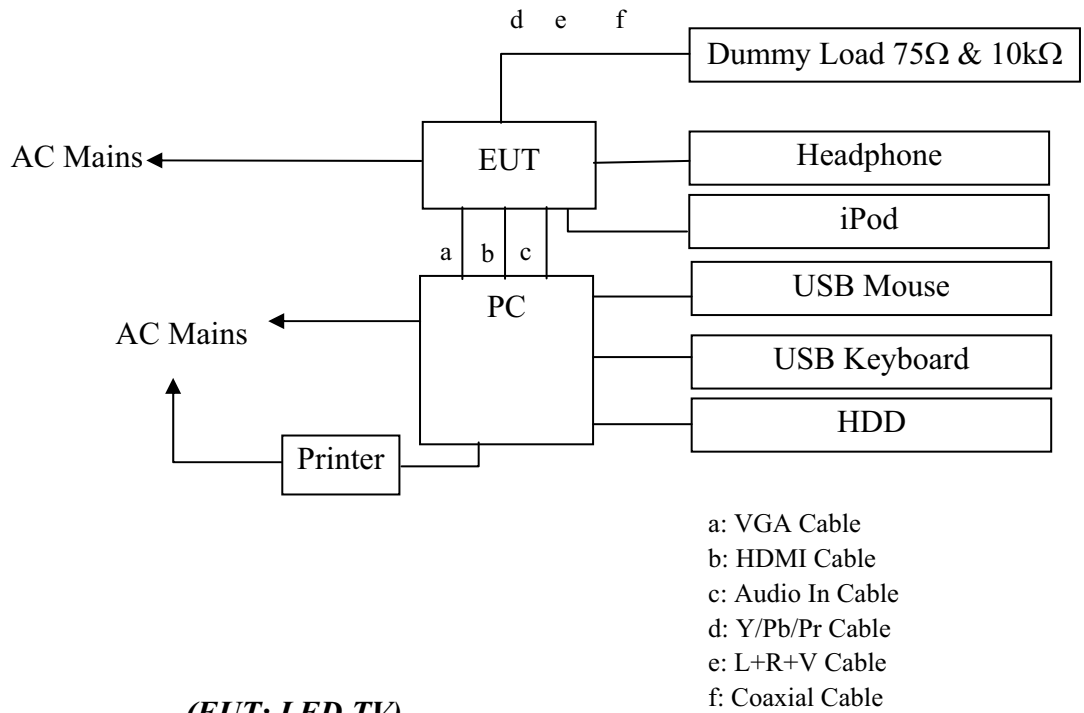

2.4. Test Facility

Site Description Name of Firm	:	Audix Technology (Shenzhen) Co., Ltd. No. 6, Ke Feng Rd., 52 Block, Shenzhen Science & Industrial Park, Nantou, Shenzhen, Guangdong, China
3m Anechoic Chamber	:	Mar. 31, 2009 File on Federal Communication Commission Registration Number: 90454
3m & 10m Anechoic Chamber	:	Dec.30, 2009 File on Federal Communication Commission Registration Number: 794232
EMC Lab.	:	Accredited by DATech, German Registration Number: DAT-P-091/99-01 Feb,02, 2009 Accredited by NVLAP, USA NVLAP Code: 200372-0 Apr. 01, 2010

2.5. Measurement Uncertainty (95% confidence levels, k=2)

Test Item	Uncertainty
Uncertainty for Conduction emission test in No. 1 Conduction	3.64 dB (9kHz to 150kHz)
	3.22 dB(150kHz to 30MHz)
Uncertainty for Radiation Emission test in 3m chamber	4.20 dB (Polarize: V)
	4.66 dB (Polarize: H)
Uncertainty for test site temperature and humidity	0.3°C
	2%

3. POWER LINE CONDUCTED EMISSION TEST

3.1. Test Equipment

Item	Equipment	Manufacturer	Model No.	Serial No.	Last Cal.	Cal. Interval
1.	Test Receiver	Rohde & Schwarz	ESHS10	838693/001	Nov.05, 10	1 Year
2.	L.I.S.N.#1	Rohde & Schwarz	ESH2-Z5	834066/011	Mar.30, 10	1 Year
3.	L.I.S.N.#3	Kyoritsu	KNW-242C	8-1920-1	May.08, 10	1 Year
4.	Terminator	Hubersuhner	50Ω	No. 1	May.08, 10	1 Year
5.	RF Cable	Fujikura	3D-2W	LISN Cable 1#	May.08, 10	1Year
6.	Coaxial Switch	Anritsu	MP59B	M55367	May.08, 10	1 Year
7.	Passive Probe	Rohde & Schwarz	ESH2-Z3	299.7810.52	May.08, 10	1 Year
8.	Pulse Limiter	Rohde & Schwarz	ESH3-Z2	100341	May.08, 10	1 Year

3.2. Block Diagram of Test Setup

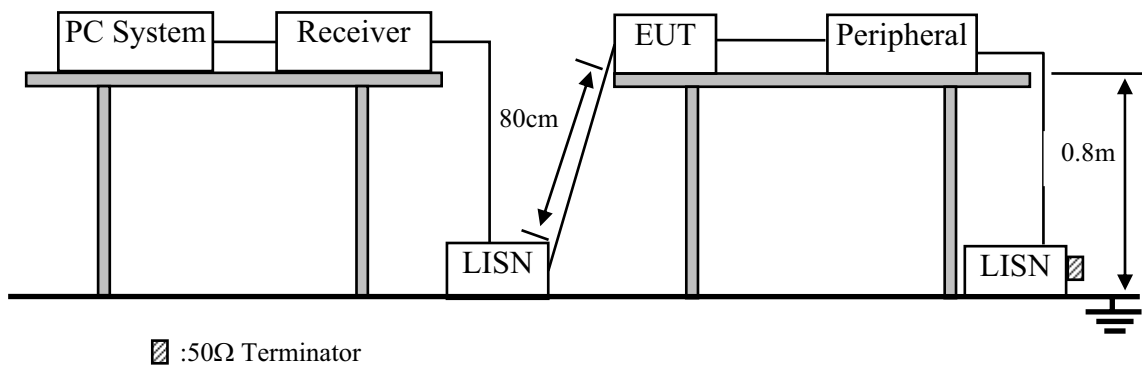

3.3. Power Line Conducted Emission Test Limits

Frequency	Maximum RF Line Voltage	
	Quasi-Peak Level dB(μV)	Average Level dB(μV)
150kHz ~ 500kHz	66 ~ 56*	56 ~ 46*
500kHz ~ 5MHz	56	46
5MHz ~ 30MHz	60	50

- Notes: 1. * Decreasing linearly with logarithm of frequency.
 2. The lower limit shall apply at the transition frequencies.

3.4. Configuration of EUT on Test

The following equipment are installed on Power Line Conducted Emission Test to meet the commission requirement and operating regulations in a manner which tends to maximize its emission characteristics in a normal application.

3.4.1. LED TV (EUT)

Model Number : LE32HDD20

Serial Number : N/A

3.4.2. Support Equipment : As Tested Supporting System Detail, in Section 2.2.

3.5. Operating Condition of EUT

3.5.1. Setup the EUT and simulator as shown as Section 4.2.

3.5.2. Turn on the power of all equipment.

3.5.3. PC system ran the Self-test program “EMC Test. exe” by windows XP and sent “H” Character to LED TV (EUT) , the Screen of EUT displayed and filled with “H” pattern, use white letters on a black background, set the contrast control to maximum, set the brightness control to maximum and measure it.

3.5.4. The PC system was running the program “1kHz signal Playing” and sending sound to EUT.

3.5.5. The other peripheral devices were driven and operated in turn during all testing.

3.6. Test Procedure

The EUT was placed on a non-metallic table, 80cm above the ground plane. The EUT Power connected to the power mains through a line impedance stabilization network (L.I.S.N. 1#). This provided a 50-ohm coupling impedance for the EUT (Please refer to the block diagram of the test setup and photographs). The other peripheral devices power cord connected to the power mains through a line impedance stabilization network (L.I.S.N.#3). Both sides of power line were checked for maximum conducted interference. In order to find the maximum emission, the relative positions of equipments and all of the interface cables were changed according to ANSI C63.4-2003 on conducted Emission test.

The bandwidth of test receiver (R&S TEST RECEIVER ESHS10) is set at 10kHz.

The frequency range from 150kHz to 30MHz is checked. The test result are reported on Section 3.7.

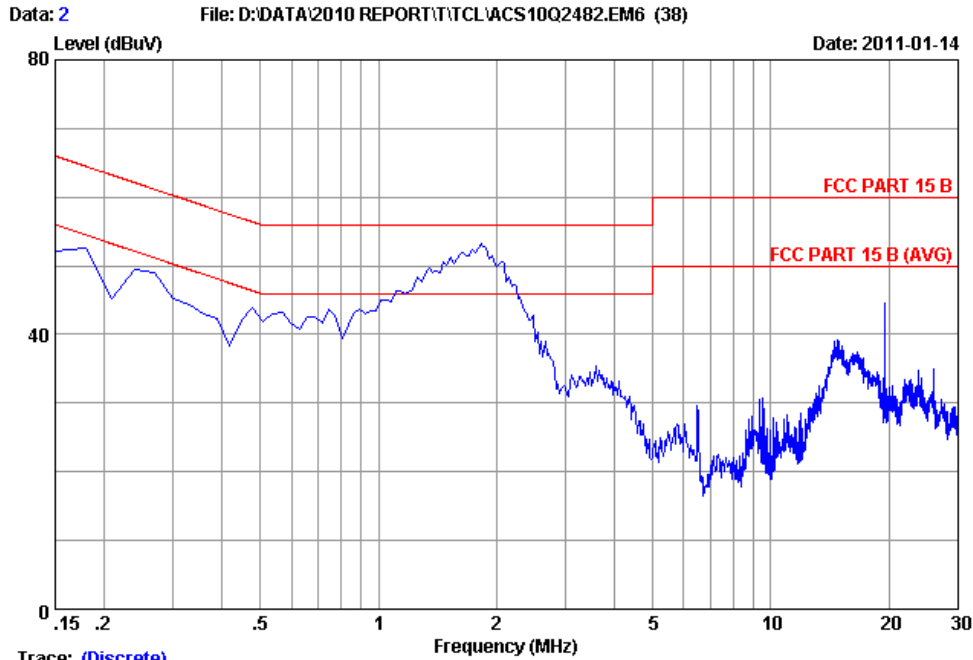

Trace: (Discrete)

Site no :1#conduction Data No :2
 Dis./Ant. **: 2011 ESH2-25 LINE
 Limit :FCC PART 15 B
 Env./Ins. :29.5°C/55% Engineer :Restar
 EUT :LED TV M/N:LE32HDD20
 Power Rating :AC 120V/60Hz
 Test Mode :Running "H" Pattern And 1kHz Playing
 VGA:640*480@60Hz

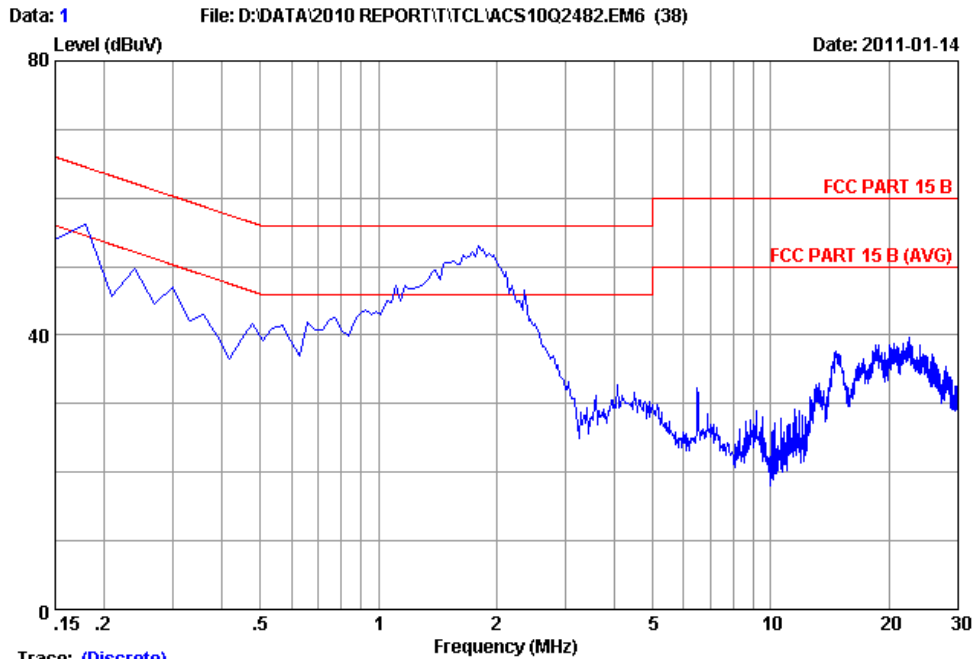

Trace: (Discrete)

Site no :1#conduction Data No :1
 Dis./Ant. **: 2011 ESH2-25 NEUTRAL
 Limit :FCC PART 15 B
 Env./Ins. :29.5°C/55% Engineer :Restar
 EUT :LED TV M/N:LE32HDD20
 Power Rating :AC 120V/60Hz
 Test Mode :Running "H" Pattern And 1kHz Playing
 VGA:640*480@60Hz

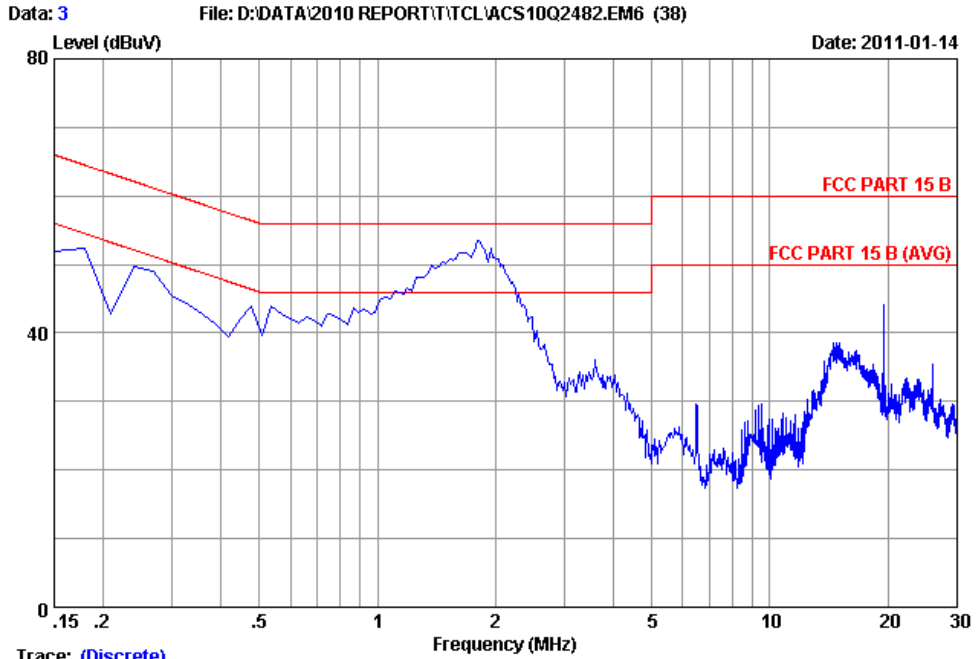

Trace: (Discrete)

Site no :1#conduction Data No :3
 Dis./Ant. **: 2011 ESH2-25 LINE
 Limit :FCC PART 15 B
 Env./Ins. :29.5°C/55% Engineer :Restar
 EUT :LED TV M/N:LE32HDD20
 Power Rating :AC 120V/60Hz
 Test Mode :Running "H" Pattern And 1kHz Playing
 VGA:800*600@60Hz

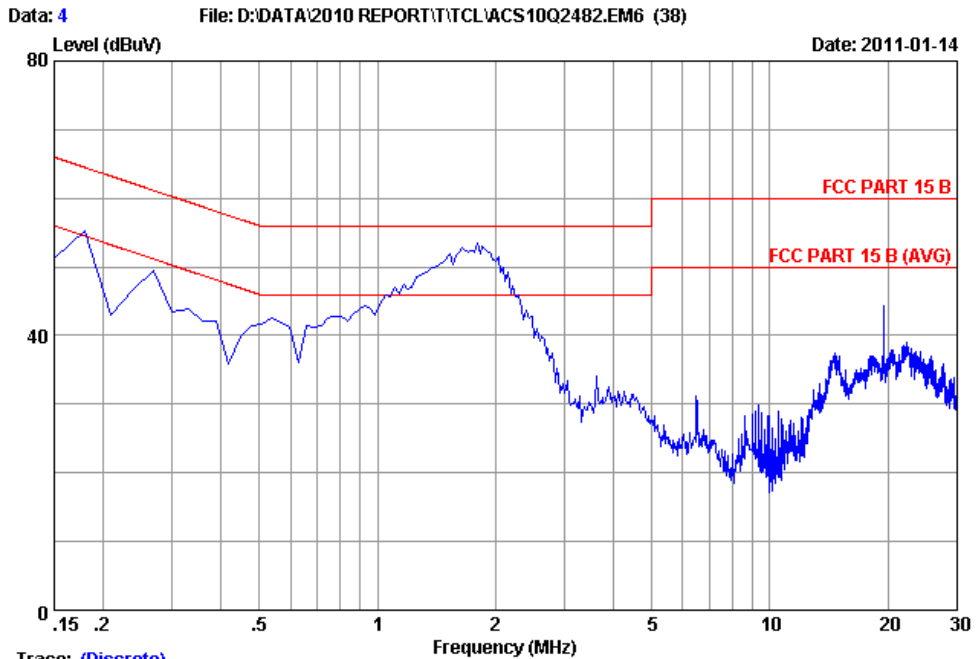

Trace: (Discrete)

Site no :1#conduction Data No :4
 Dis./Ant. **: 2011 ESH2-25 NEUTRAL
 Limit :FCC PART 15 B
 Env./Ins. :29.5°C/55% Engineer :Restar
 EUT :LED TV M/N:LE32HDD20
 Power Rating :AC 120V/60Hz
 Test Mode :Running "H" Pattern And 1kHz Playing
 VGA:800*600@60Hz

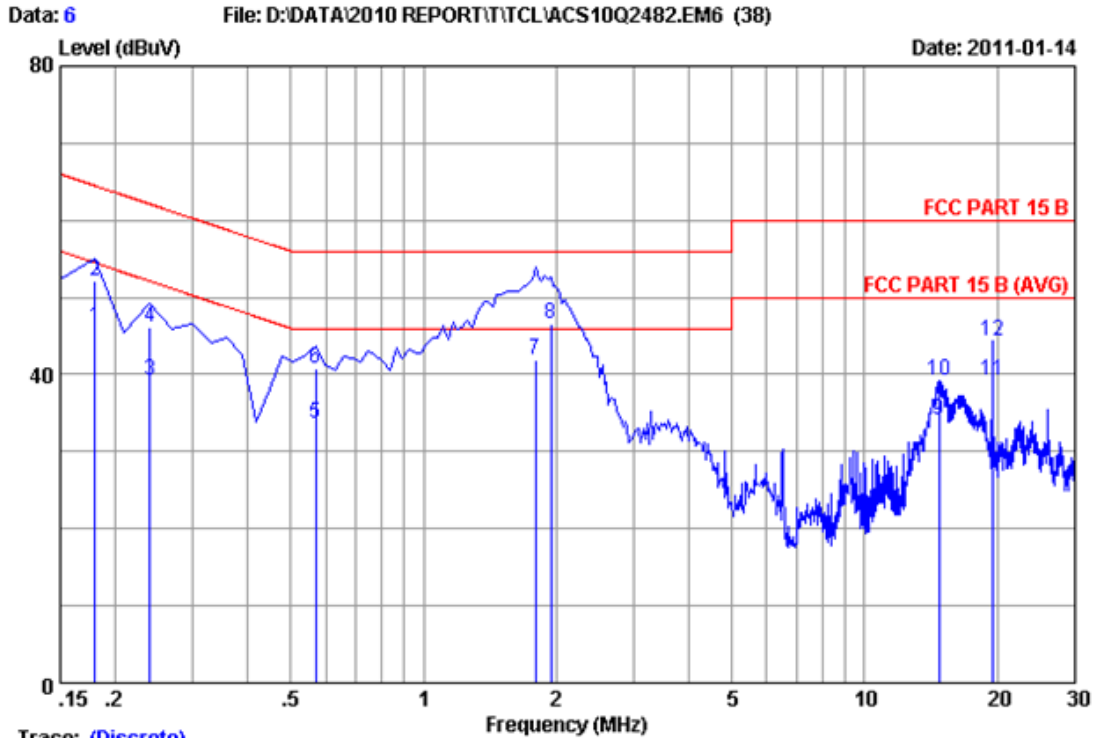

Trace: (Discrete)

Site no :1#conduction Data No :6
 Dis./Ant. :** 2011 ESH2-25 LINE
 Limit :FCC PART 15 B
 Env./Ins. :29.5°C/55% Engineer :Restar
 EUT :LED TV M/N:LE32HDD20
 Power Rating :AC 120V/60Hz
 Test Mode :Running "H" Pattern And 1kHz Playing
 VGA:1024*768@60Hz

No	Freq (MHz)	LISN Factor (dB)	Cable Loss (dB)	Reading (dBuV)	Emission Level (dBuV)	Limits (dBuV)	Margin (dB)	Remark
1	0.17985	0.17	9.88	36.01	46.06	54.49	8.43	Average
2	0.17985	0.17	9.88	42.01	52.06	64.49	12.43	QP
3	0.23955	0.17	9.88	29.18	39.23	52.11	12.88	Average
4	0.23955	0.17	9.88	36.18	46.23	62.11	15.88	QP
5	0.56790	0.19	9.88	23.66	33.73	46.00	12.27	Average
6	0.56790	0.19	9.88	30.66	40.73	56.00	15.27	QP
7	1.792	0.29	9.90	31.72	41.91	46.00	4.09	Average
8	1.941	0.31	9.90	36.31	46.52	56.00	9.48	QP
9	14.717	0.95	10.03	23.14	34.12	50.00	15.88	Average
10	14.717	0.95	10.03	28.14	39.12	60.00	20.88	QP
11	19.493	0.99	10.08	28.17	39.24	50.00	10.76	Average
12	19.493	0.99	10.08	33.17	44.24	60.00	15.76	QP

Remarks: 1.Emission Level=LISN Factor+Cable Loss(Include 10dB pulse limit)+Reading.
 2.If the average limit is met when using a quasi-peak detector. the EUT shall be deemed to meet both limits and measurement with average detector is unnecessary.

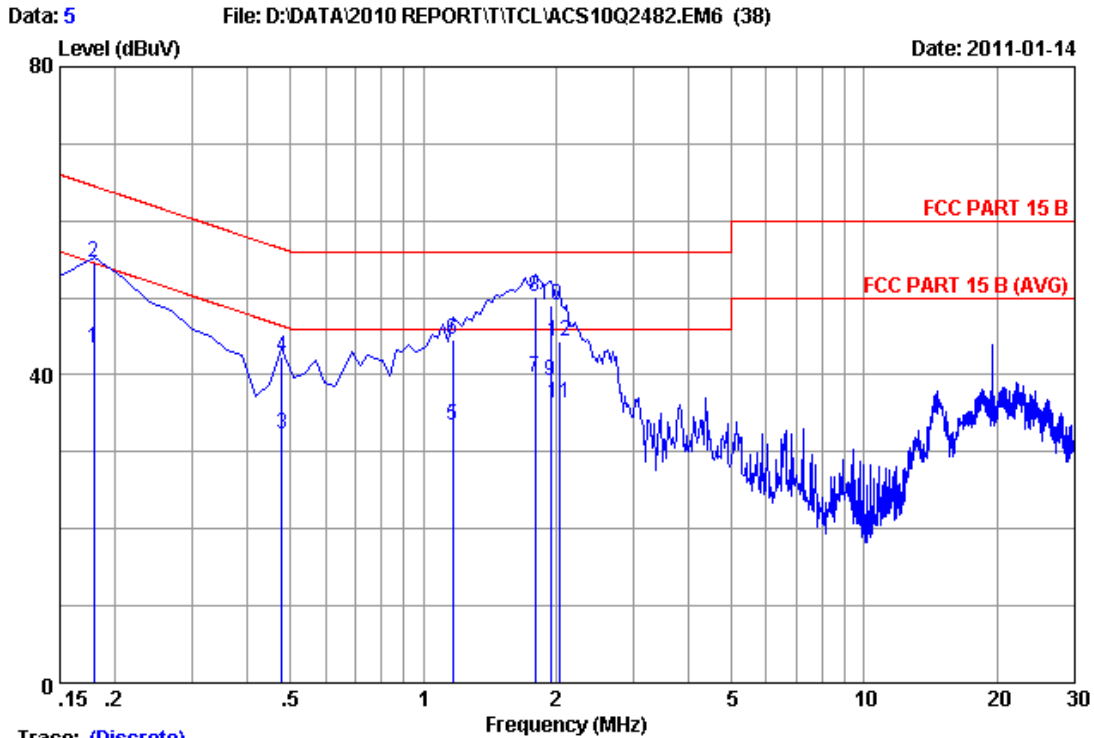

Trace: (Discrete)

Site no : 1#conduction Data No : 5
 Dis./Ant. : ** 2011 ESH2-Z5 NEUTRAL
 Limit : FCC PART 15 B
 Env./Ins. : 29.5°C/55% Engineer : Restar
 EUT : LED TV M/N:LE32HDD20
 Power Rating : AC 120V/60Hz
 Test Mode : Running "H" Pattern And 1kHz Playing
 VGA:1024*768@60Hz

No	Freq (MHz)	LISN Factor (dB)	Cable Loss (dB)	Reading (dBUV)	Emission Level (dBUV)	Limits (dBUV)	Margin (dB)	Remark
1	0.17900	0.21	9.88	33.40	43.49	54.53	11.04	Average
2	0.17900	0.21	9.88	44.40	54.49	64.53	10.04	QP
3	0.47835	0.22	9.88	22.29	32.39	46.37	13.98	Average
4	0.47835	0.22	9.88	32.29	42.39	56.37	13.98	QP
5	1.165	0.25	9.89	23.37	33.51	46.00	12.49	Average
6	1.165	0.25	9.89	34.37	44.51	56.00	11.49	QP
7	1.791	0.26	9.90	29.40	39.56	46.00	6.44	Average
8	1.791	0.26	9.90	40.00	50.16	56.00	5.84	QP
9	1.948	0.27	9.90	29.10	39.27	46.00	6.73	Average
10	1.948	0.27	9.90	38.90	49.07	56.00	6.93	QP
11	2.031	0.27	9.91	26.07	36.25	46.00	9.75	Average
12	2.031	0.27	9.91	34.07	44.25	56.00	11.75	QP

Remarks: 1. Emission Level=LISN Factor+Cable Loss (Include 10dB pulse limit) +Reading.
 2. If the average limit is met when using a quasi-peak detector, the EUT shall be deemed to meet both limits and measurement with average detector is unnecessary.

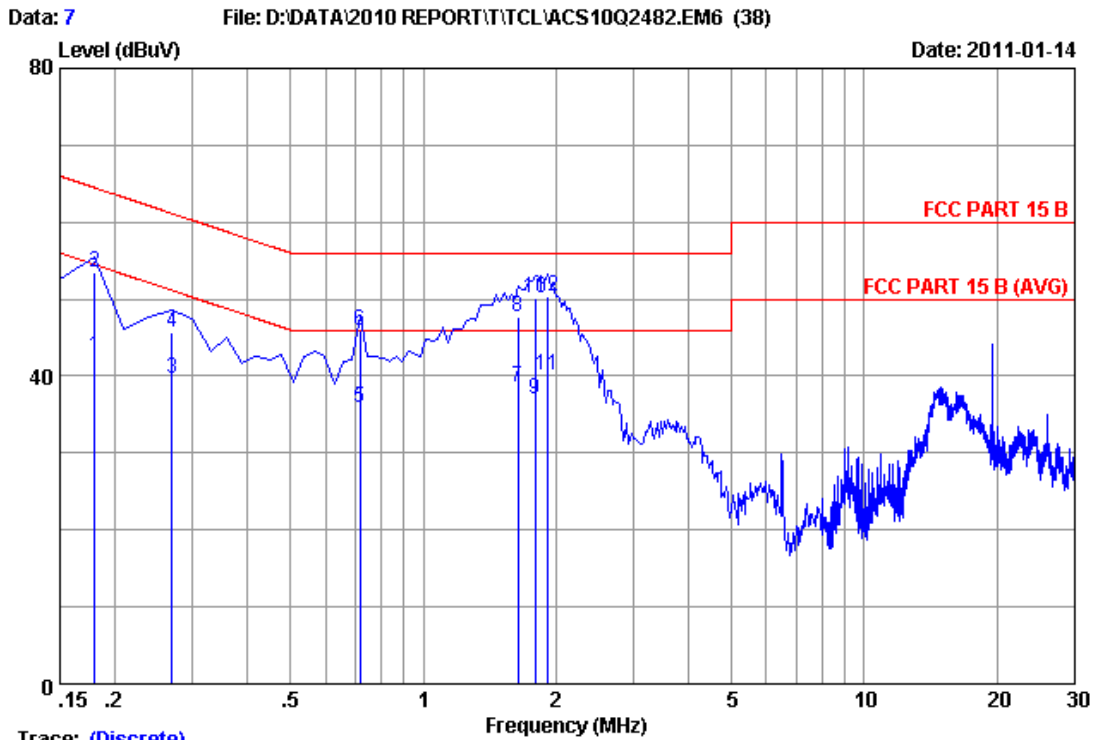

Trace: (Discrete)

Site no :1#conduction Data No :7
 Dis./Ant. **: 2011 ESH2-25 LINE
 Limit :FCC PART 15 B
 Env./Ins. :29.5°C/55% Engineer :Restar
 EUT :LED TV M/N:LE32HDD20
 Power Rating :AC 120V/60Hz
 Test Mode :Running "H" Pattern And 1kHz Playing
 HDMI 1:1080P

No	Freq (MHz)	LISN Factor (dB)	Cable Loss (dB)	Reading (dBuV)	Emission Level (dBuV)	Limits (dBuV)	Margin (dB)	Remark
1	0.17985	0.17	9.88	32.53	42.58	54.49	11.91	Average
2	0.17985	0.17	9.88	43.53	53.58	64.49	10.91	QP
3	0.26940	0.18	9.88	29.62	39.68	51.14	11.46	Average
4	0.26940	0.18	9.88	35.62	45.68	61.14	15.46	QP
5	0.71715	0.19	9.89	25.81	35.89	46.00	10.11	Average
6	0.71715	0.19	9.89	35.81	45.89	56.00	10.11	QP
7	1.643	0.28	9.90	28.48	38.66	46.00	7.34	Average
8	1.643	0.28	9.90	37.48	47.66	56.00	8.34	QP
9	1.792	0.29	9.90	26.84	37.03	46.00	8.97	Average
10	1.792	0.29	9.90	39.84	50.03	56.00	5.97	QP
11	1.911	0.30	9.90	29.91	40.11	46.00	5.89	Average
12	1.911	0.30	9.90	40.21	50.41	56.00	5.59	QP

Remarks: 1.Emission Level=LISN Factor+Cable Loss(Include 10dB pulse limit)+Reading.
 2.If the average limit is met when using a quasi-peak detector, the EUT shall be deemed to meet both limits and measurement with average detector is unnecessary.

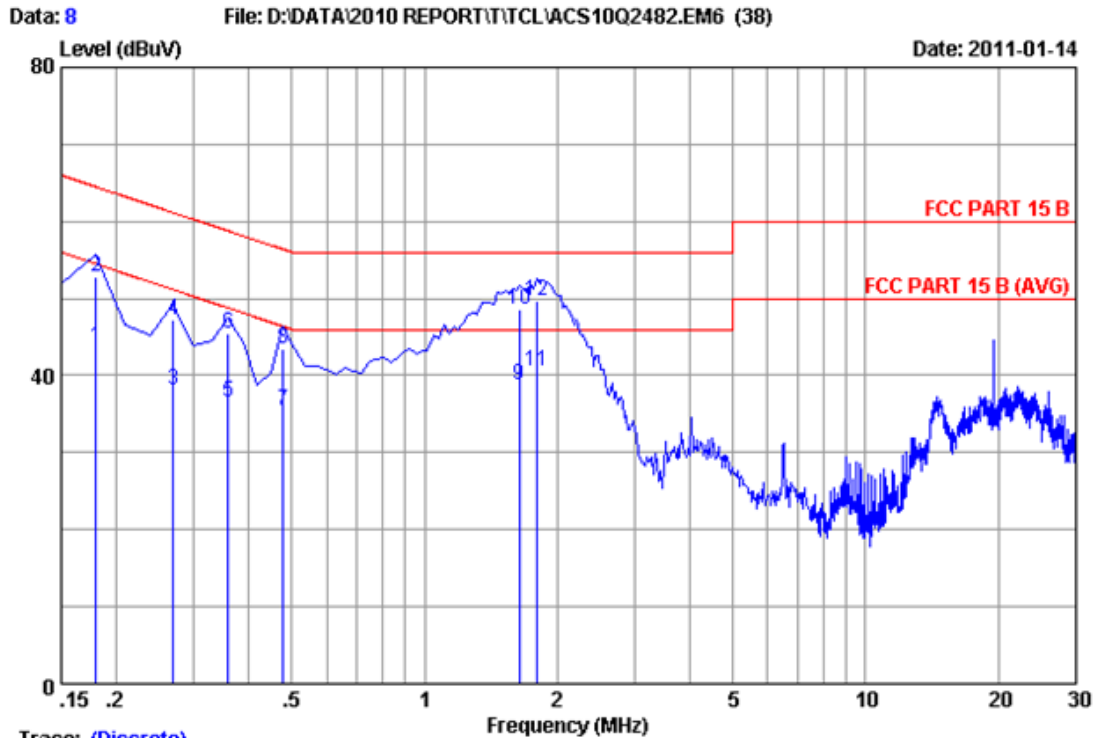

Trace: (Discrete)

Site no :1#conduction Data No :8
 Dis./Ant. :** 2011 ESH2-Z5 NEUTRAL
 Limit :FCC PART 15 B
 Env./Ins. :29.5*C/55% Engineer :Restar
 EUT :LED TV M/N:LE32HDD20
 Power Rating :AC 120V/60Hz
 Test Mode :Running "H" Pattern And 1kHz Playing
 HDMI 1:1080P

No	Freq (MHz)	LISN Factor (dB)	Cable Loss (dB)	Reading (dBuV)	Emission Level (dBuV)	Limits (dBuV)	Margin (dB)	Remark
1	0.17985	0.21	9.88	33.67	43.76	54.49	10.73	Average
2	0.17985	0.21	9.88	42.67	52.76	64.49	11.73	QP
3	0.26940	0.21	9.88	28.06	38.15	51.14	12.99	Average
4	0.26940	0.21	9.88	37.06	47.15	61.14	13.99	QP
5	0.35895	0.22	9.88	26.37	36.47	48.75	12.28	Average
6	0.35895	0.22	9.88	35.37	45.47	58.75	13.28	QP
7	0.47835	0.22	9.88	25.36	35.46	46.37	10.91	Average
8	0.47835	0.22	9.88	33.36	43.46	56.37	12.91	QP
9	1.643	0.26	9.90	28.52	38.68	46.00	7.32	Average
10	1.643	0.26	9.90	38.52	48.68	56.00	7.32	QP
11	1.792	0.26	9.90	30.50	40.66	46.00	5.34	Average
12	1.792	0.26	9.90	39.50	49.66	56.00	6.34	QP

Remarks: 1.Emission Level=LISN Factor+Cable Loss(Include 10dB pulse limit)+Reading.
 2.If the average limit is met when using a quasi-peak detector. the EUT shall be deemed to meet both limits and measurement with average detector is unnecessary.

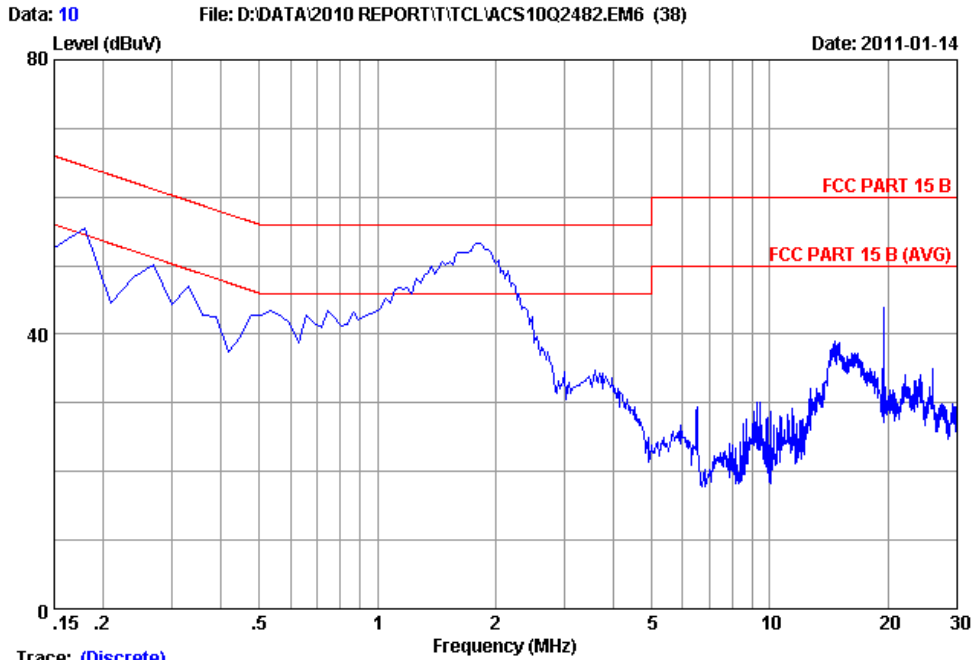

Trace: (Discrete)

Site no	:1#conduction	Data No	:10
Dis./Ant.	:** 2011 ESH2-25 LINE		
Limit	:FCC PART 15 B		
Env./Ins.	:29.5°C/55%	Engineer	:Restar
EUT	:LED TV M/N:LE32HDD20		
Power Rating	:AC 120V/60Hz		
Test Mode	:Running "H" Pattern And 1kHz Playing		
	HDMI 2:1080P		

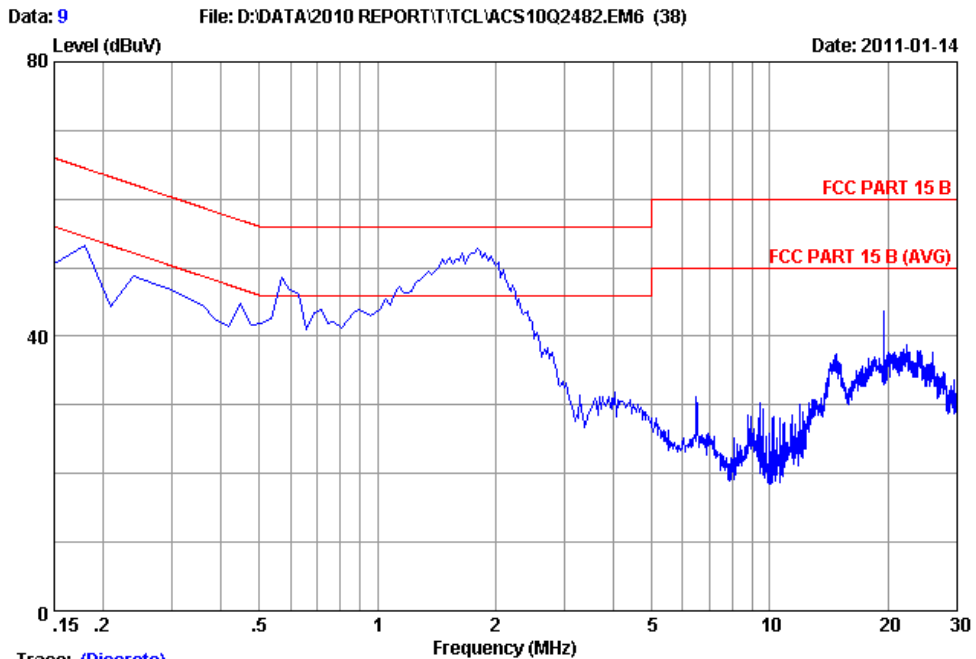

Trace: (Discrete)

Site no	:1#conduction	Data No	:9
Dis./Ant.	:** 2011 ESH2-25 NEUTRAL		
Limit	:FCC PART 15 B		
Env./Ins.	:29.5°C/55%	Engineer	:Restar
EUT	:LED TV M/N:LE32HDD20		
Power Rating	:AC 120V/60Hz		
Test Mode	:Running "H" Pattern And 1kHz Playing		
	HDMI 2:1080P		

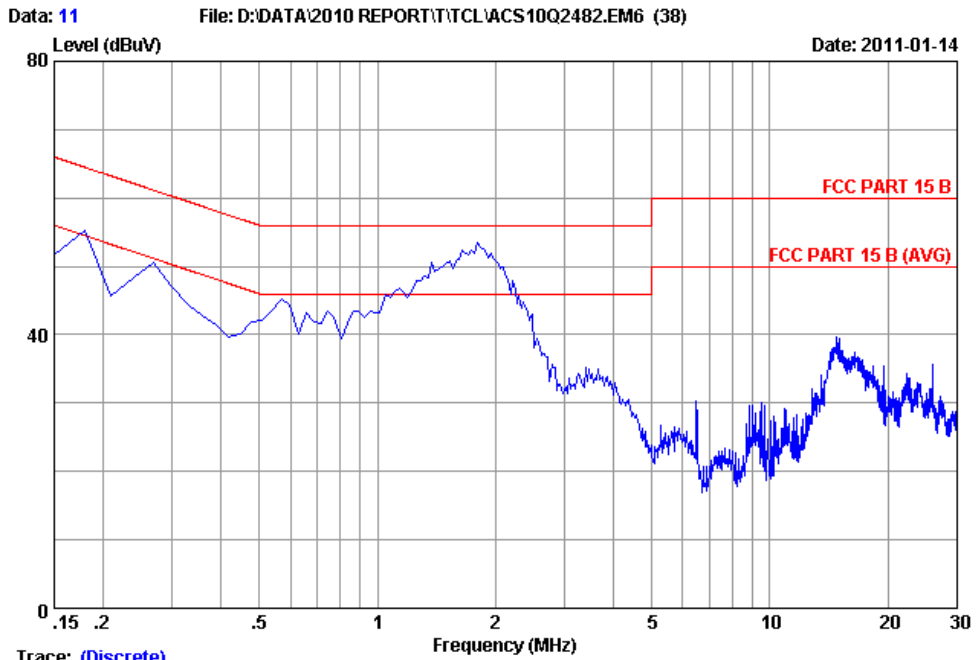

Trace: (Discrete)

Site no :1#conduction Data No :11
 Dis./Ant. **: 2011 ESH2-25 LINE
 Limit :FCC PART 15 B
 Env./Ins. :29.5°C/55% Engineer :Restar
 EUT :LED TV M/N:LE32HDD20
 Power Rating :AC 120V/60Hz
 Test Mode :Running "H" Pattern And 1kHz Playing
 HDMI 3:1080P

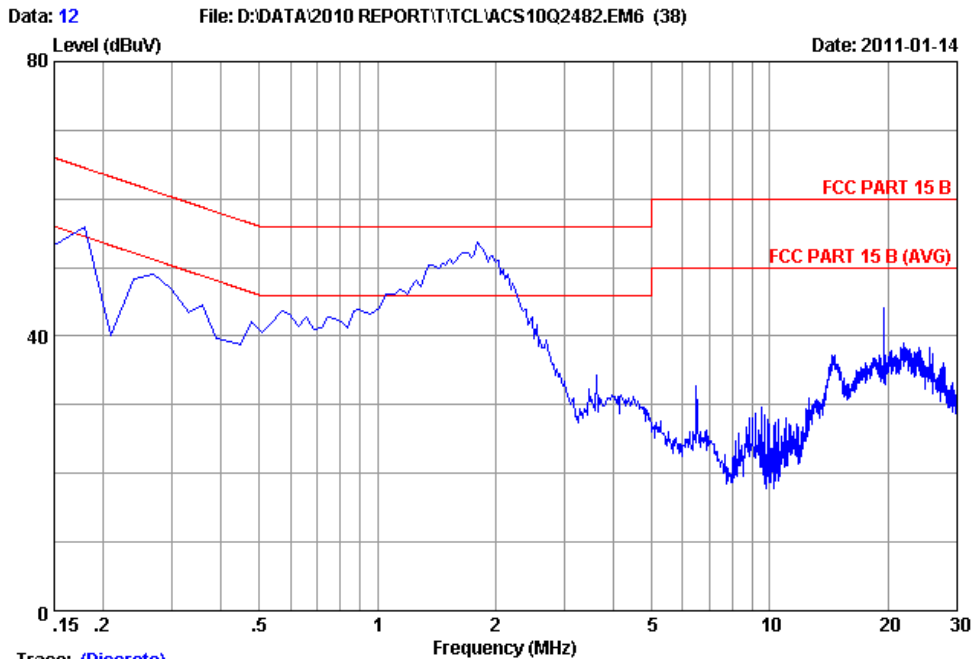

Trace: (Discrete)

Site no :1#conduction Data No :12
 Dis./Ant. **: 2011 ESH2-25 NEUTRAL
 Limit :FCC PART 15 B
 Env./Ins. :29.5°C/55% Engineer :Restar
 EUT :LED TV M/N:LE32HDD20
 Power Rating :AC 120V/60Hz
 Test Mode :Running "H" Pattern And 1kHz Playing
 HDMI 3:1080P

4. RADIATED EMISSION TEST

4.1. Test Equipment

4.1.1. For frequency range 30MHz~1000MHz

Item	Equipment	Manufacturer	Model No.	Serial No.	Last Cal.	Cal. Interval
1	3#Chamber	AUDIX	N/A	N/A	Dec.05,10	1 Year
2	EMI Spectrum	Agilent	E4407B	MY41440292	May.08, 10	1 Year
3	Test Receiver	Rohde & Schwarz	ESVS10	834468/011	May.08, 10	1 Year
4	Amplifier	HP	8447D	2648A04738	May.08, 10	1 Year
5	Bilog Antenna	Schaffner	CBL6111C	2598	Mar.27, 10	1 Year
6	RF Cable	MIYAZAKI	8D-FB	3# Chamber No.1	May.08, 10	1 Year
7	Coaxial Switch	Anritsu	MP59B	M73989	May.08, 10	1 Year

4.1.2. For frequency range 1GHz~6GHz

Item	Equipment	Manufacturer	Model No.	Serial No.	Last Cal.	Cal. Interval
1	Spectrum Analyzer	Agilent	E7405A	MY45116588	May.08, 10	1 Year
2	Horn Antenna	EMCO	3115	9607-4877	Nov.25, 09	1.5 Year
3	Amplifier	Agilent	8449B	3008A00863	May.08, 10	1 Year
4	RF Cable	Hubersuhner	SUCOFLEX102	28620/2	May.08, 10	1 Year
5	RF Cable	Hubersuhner	SUCOFLEX102	29091/2	May.08, 10	1 Year

4.2. Block Diagram of Test Setup

For frequency range 30MHz-1000MHz

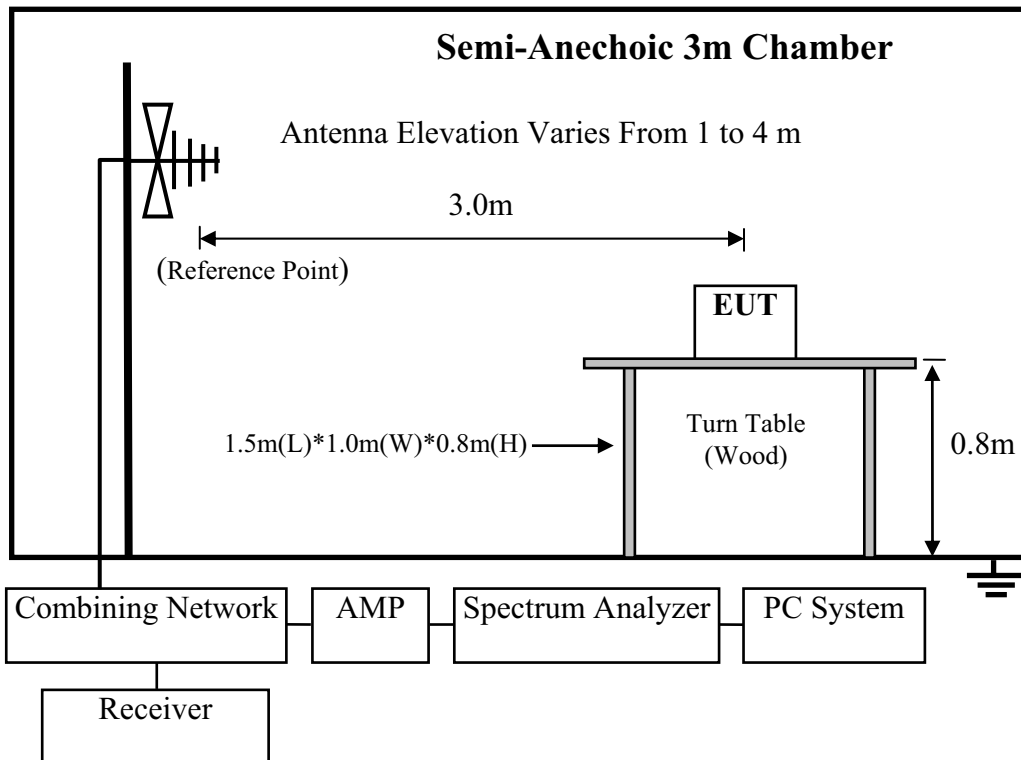

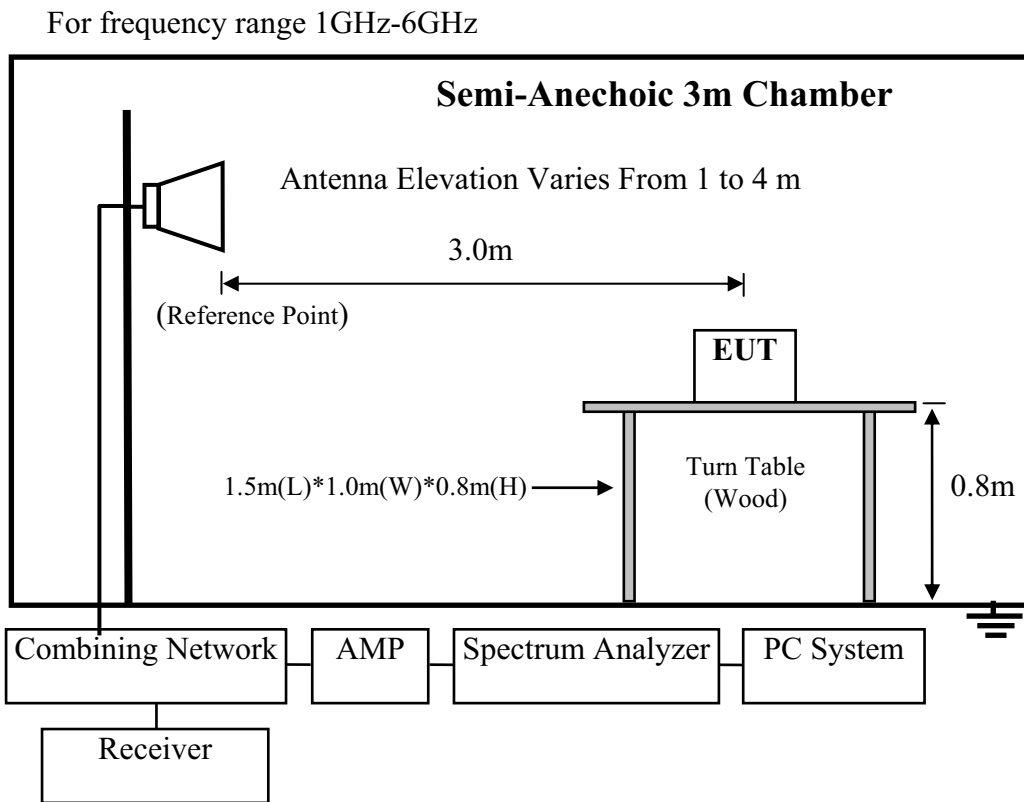

4.3. Radiated Emission Limit

Frequency MHz	Distance (Meters)	Field Strengths Limits dB(μV)/m
30 ~ 88	3	40.0
88 ~ 216	3	43.5
216 ~ 960	3	46.0
960 ~ 1000	3	54.0
Above 6000	3	74(Peak)54(Average)

- Remark: (1) Emission level = Antenna Factor + Cable Loss + Reading
 Emission level = Antenna Factor - Amp Factor + Cable Loss + Reading (above 1000MHz)
- (2) The smaller limit shall apply at the cross point between two frequency bands.
- (3) Distance is the distance in meters between the measuring instrument, antenna and the closest point of any part of the device or system.

4.4. EUT Configuration on Test

The configurations of EUT are listed in Section 3.4

4.5. Operating Condition of EUT

Same as Conducted Emission test that is listed in Section 3.5. except the test set up replaced by Section 4.2.

For frequency range 1GHz~6GHz

The EUT with below test modes ere measured within Anechoic Chamber and the test results listed in next pages

Test Date: Jan.20, 2011

Temperature: 24℃

Humidity: 56%

NO.	Test Mode	Resolution & Frequency	Reference Test Data No.	
			Horizontal	Vertical
1.	VGA	1024*768 @60Hz	#41 #42	#39 #40
2.	HDMI1	1080P	#47 #48	#49 #50
3.	HDMI2	1080P	#53 #54	#51 #52
4.	HDMI3	1080P	#43 #44	#45 #46

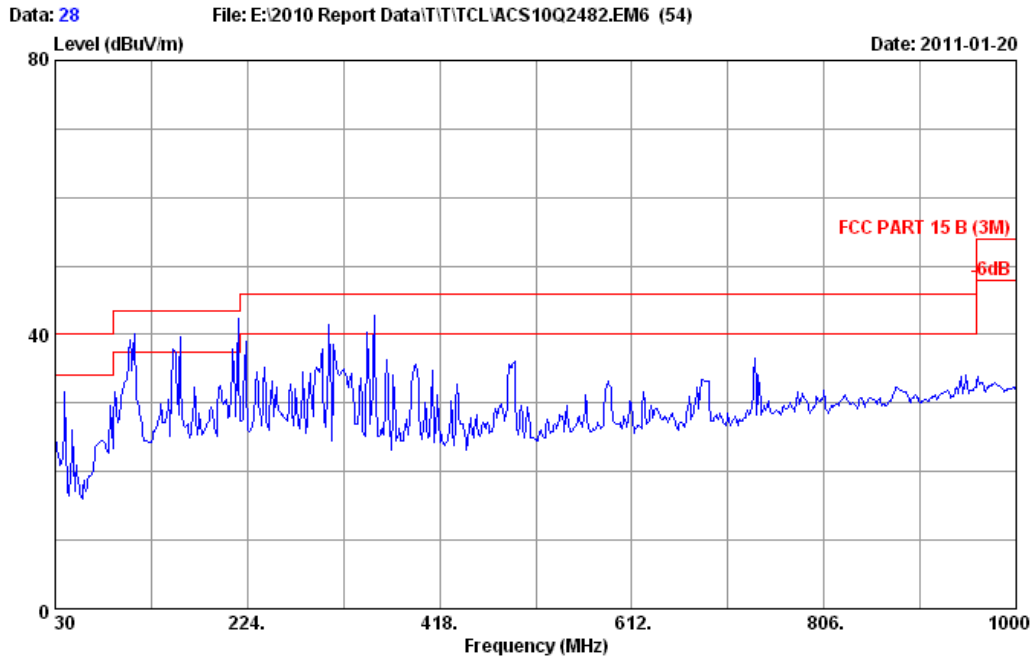

Site no.	: 3m Chamber	Data no.	: 28
Dis. / Ant.	: 3m 2010 CBL6111C	Ant. pol.	: HORIZONTAL
Limit	: FCC PART 15 B (3M)	Engineer	: Victory
Env. / Ins.	: 24°C/56%		
EUT	: LED TV M/N:LE32HDD20		
Power rating	: AC 120V/60Hz		
Test Mode	: PC MODE		
	Running "H" Pattern And 1KHz Playing		
	VGA:640*480@60Hz		

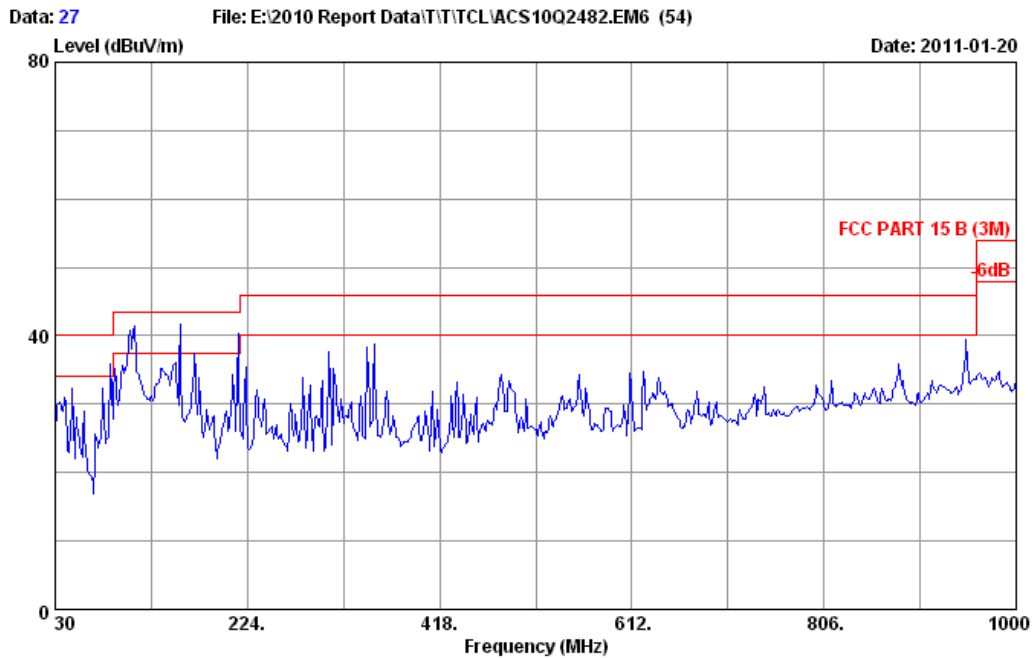

Site no.	: 3m Chamber	Data no.	: 27
Dis. / Ant.	: 3m 2010 CBL6111C	Ant. pol.	: VERTICAL
Limit	: FCC PART 15 B (3M)	Engineer	: Victory
Env. / Ins.	: 24°C/56%		
EUT	: LED TV M/N:LE32HDD20		
Power rating	: AC 120V/60Hz		
Test Mode	: PC MODE		
	Running "H" Pattern And 1KHz Playing		
	VGA:640*480@60Hz		

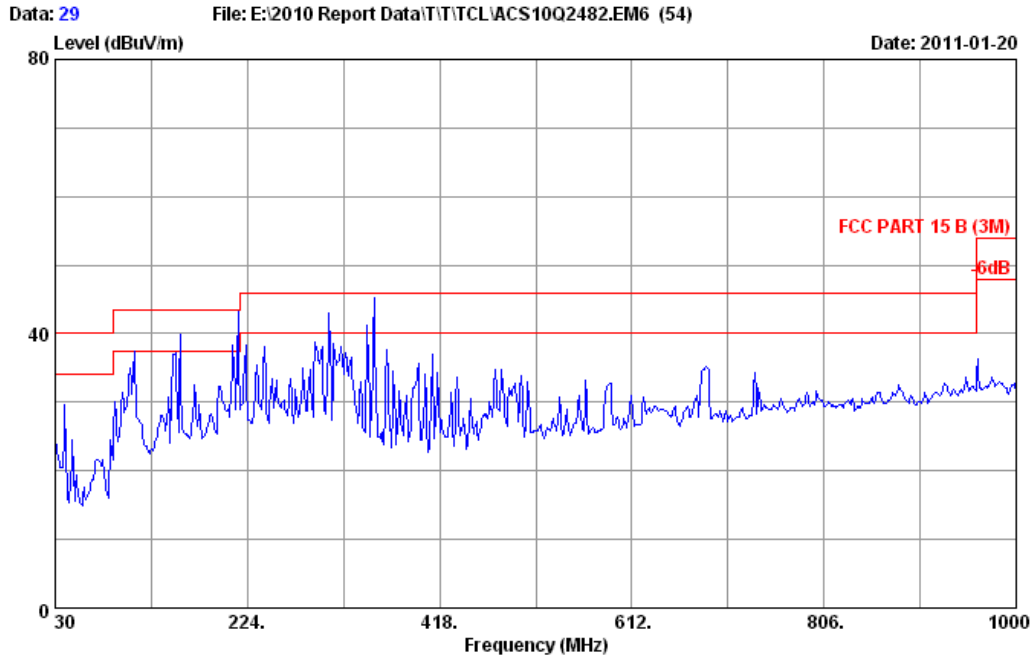

Site no. : 3m Chamber	Data no. : 29
Dis. / Ant. : 3m 2010 CBL6111C	Ant. pol. : HORIZONTAL
Limit : FCC PART 15 B (3M)	
Env. / Ins. : 24°C/56%	Engineer : Victory
EUT : LED TV M/N:LE32HDD20	
Power rating : AC 120V/60Hz	
Test Mode : PC MODE	
Runnning "H" Pattern And 1KHz Playing	
VGA:800*600@60Hz	

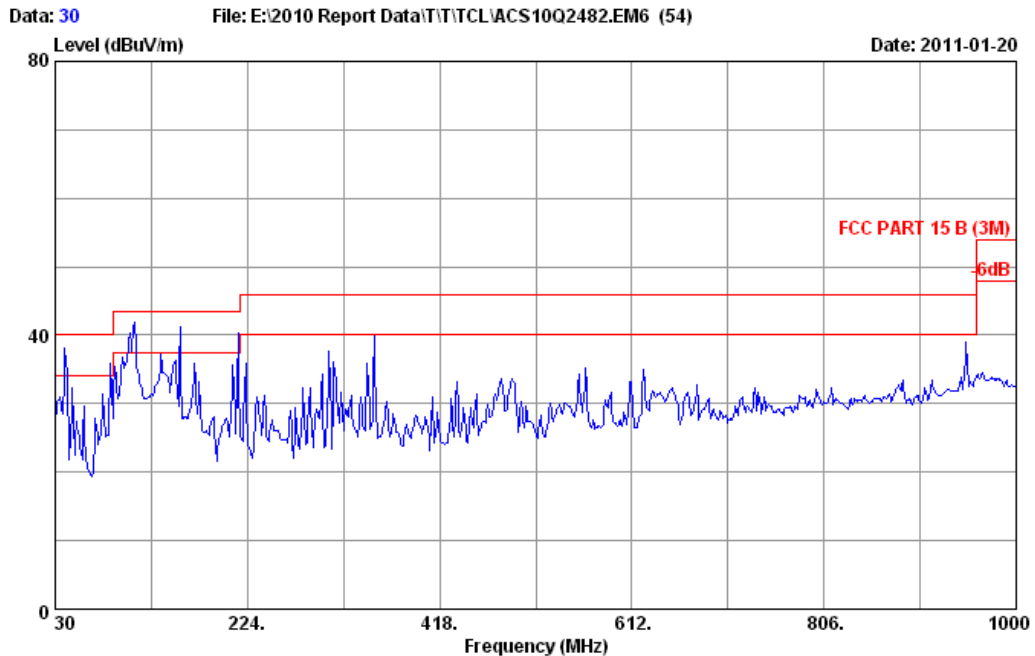

Site no. : 3m Chamber	Data no. : 30
Dis. / Ant. : 3m 2010 CBL6111C	Ant. pol. : VERTICAL
Limit : FCC PART 15 B (3M)	
Env. / Ins. : 24°C/56%	Engineer : Victory
EUT : LED TV M/N:LE32HDD20	
Power rating : AC 120V/60Hz	
Test Mode : PC MODE	
Runnning "H" Pattern And 1KHz Playing	
VGA:800*600@60Hz	

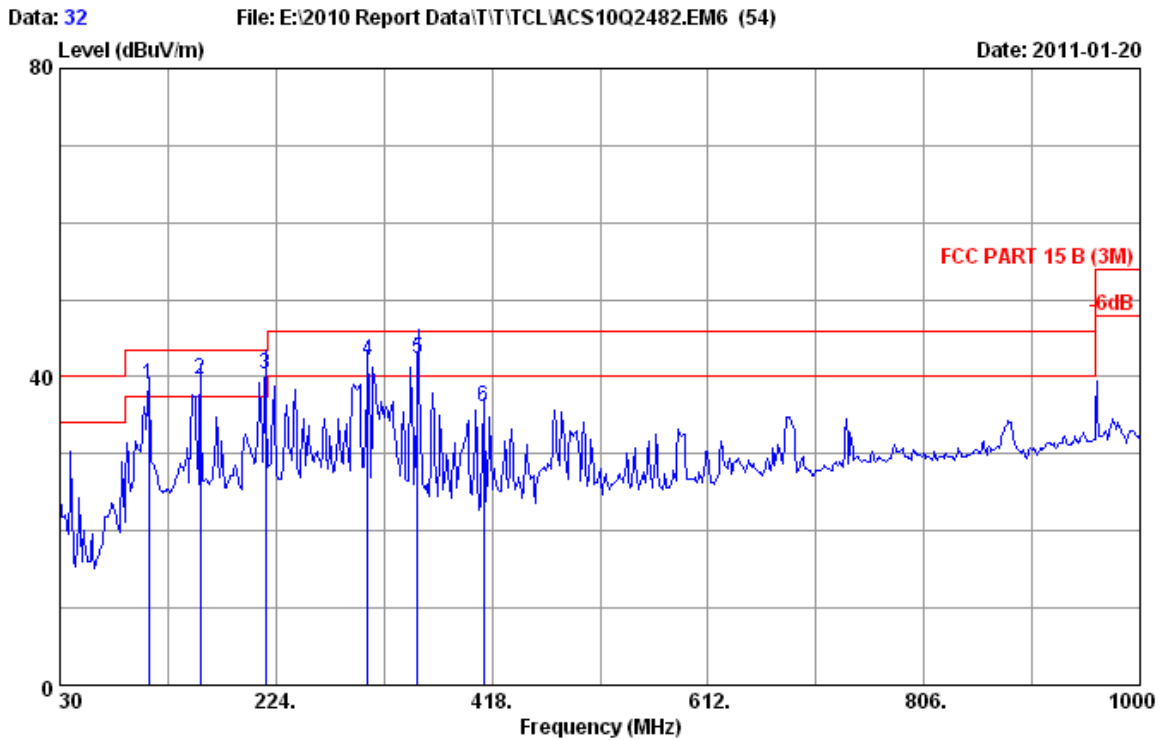

Site no. : 3m Chamber Data no. : 32
 Dis. / Ant. : 3m 2010 CBL6111C Ant. pol. : HORIZONTAL
 Limit : FCC PART 15 B (3M)
 Env. / Ins. : 24°C/56% Engineer : Victory
 EUT : LED TV M/N:LE32HDD20
 Power rating : AC 120V/60Hz
 Test Mode : PC MODE
 Running "H" Pattern And 1KHz Playing
 VGA:1024*768@60Hz

No.	Freq. (MHz)	Ant. Factor (dB/m)	Cable Loss (dB)	Reading (dBuV)	Emission Level (dBuV/m)	Limits (dBuV/m)	Margin (dB)	Remark
1	109.540	11.40	1.12	26.43	38.95	43.50	4.55	QP
2	156.100	11.26	1.21	27.26	39.73	43.50	3.77	QP
3	214.300	10.02	1.85	28.40	40.27	43.50	3.23	QP
4	306.450	13.89	2.51	25.82	42.22	46.00	3.78	QP
5	350.830	15.15	2.70	24.50	42.35	46.00	3.65	QP
6	410.240	16.50	2.98	16.62	36.10	46.00	9.90	QP

Remarks: 1. Emission Level= Antenna Factor + Cable Loss + Reading.
 2. The emission levels that are 20dB below the official limit are not reported.

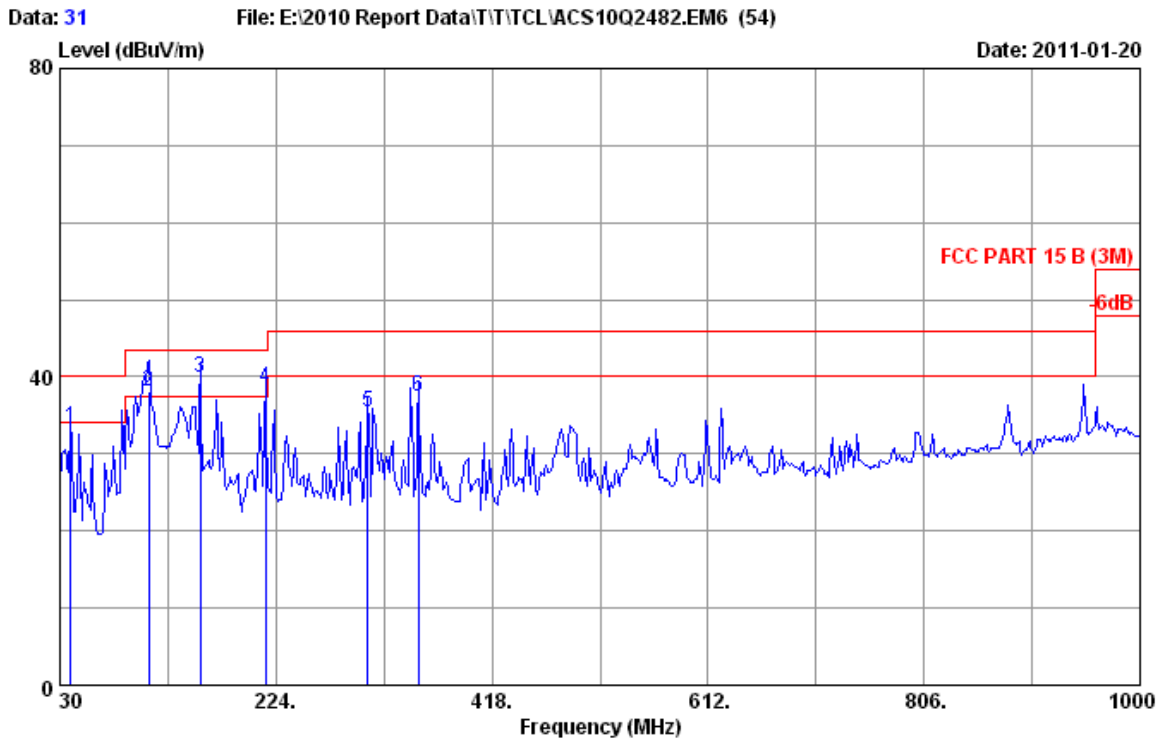

Site no. : 3m Chamber Data no. : 31
 Dis. / Ant. : 3m 2010 CBL6111C Ant. pol. : VERTICAL
 Limit : FCC PART 15 B (3M)
 Env. / Ins. : 24°C/56% Engineer : Victory
 EUT : LED TV M/N:LE32HDD20
 Power rating : AC 120V/60Hz
 Test Mode : PC MODE
 Running "H" Pattern And 1KHz Playing
 VGA:1024*768@60Hz

No.	Freq. (MHz)	Ant. Factor (dB/m)	Cable Loss (dB)	Reading (dBuV)	Emission Level (dBuV/m)	Limits (dBuV/m)	Margin (dB)	Remark
1	39.700	14.50	0.69	18.28	33.47	40.00	6.53	QP
2	109.540	11.40	1.12	25.69	38.21	43.50	5.29	QP
3	156.100	11.26	1.21	27.49	39.96	43.50	3.54	QP
4	214.300	10.02	1.85	26.58	38.45	43.50	5.05	QP
5	306.450	13.89	2.51	19.01	35.41	46.00	10.59	QP
6	352.040	15.20	2.71	19.54	37.45	46.00	8.55	QP

Remarks: 1. Emission Level= Antenna Factor + Cable Loss + Reading.
 2. The emission levels that are 20dB below the official limit are not reported.

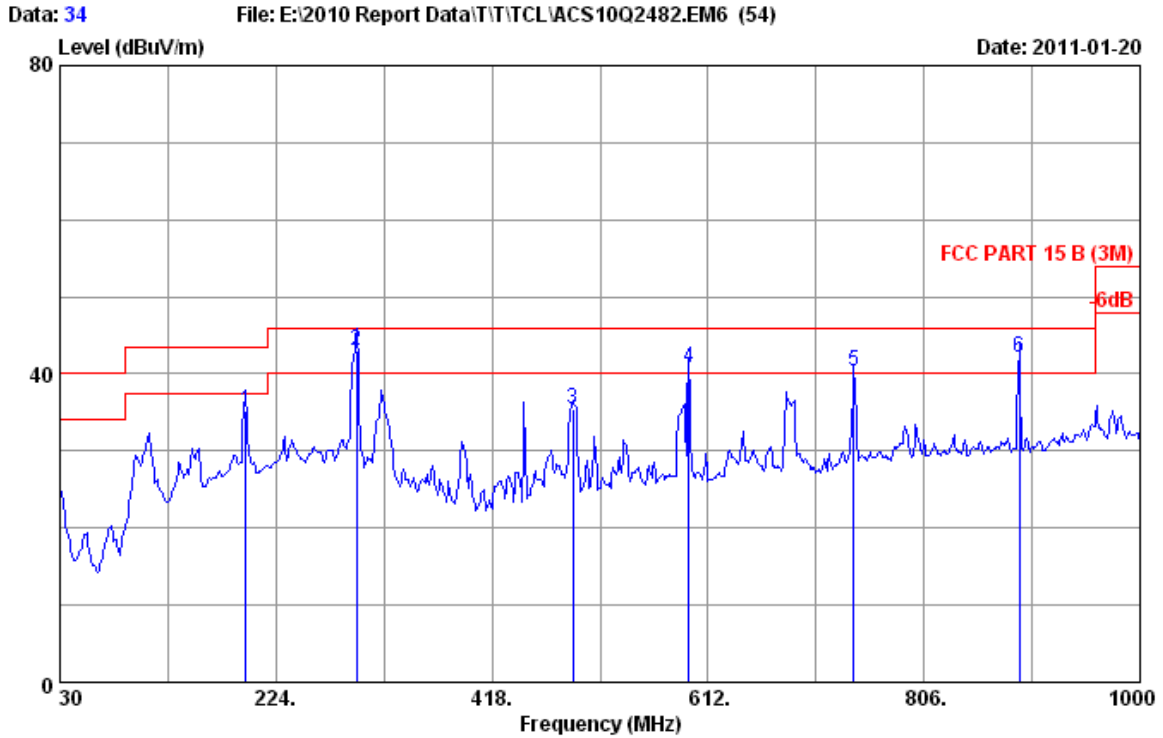

Site no. : 3m Chamber Data no. : 34
 Dis. / Ant. : 3m 2010 CBL6111C Ant. pol. : HORIZONTAL
 Limit : FCC PART 15 B (3M)
 Env. / Ins. : 24°C/56% Engineer : Victory
 EUT : LED TV M/N:LE32HDD20
 Power rating : AC 120V/60Hz
 Test Mode : PC MODE
 Running "H" Pattern And 1KHz Playing
 HDMI1:1080P

No.	Freq. (MHz)	Ant. Factor (dB/m)	Cable Loss (dB)	Reading (dBUV)	Emission Level (dBUV/m)	Limits (dBUV/m)	Margin (dB)	Remark
1	196.840	9.82	1.69	23.60	35.11	43.50	8.39	QP
2	296.750	13.70	2.46	26.77	42.93	46.00	3.07	QP
3	490.750	18.21	3.49	13.80	35.50	46.00	10.50	QP
4	594.540	19.85	4.09	16.87	40.81	46.00	5.19	QP
5	742.950	21.86	4.67	13.78	40.31	46.00	5.69	QP
6	891.360	22.89	5.17	14.01	42.07	46.00	3.93	QP

Remarks: 1. Emission Level= Antenna Factor + Cable Loss + Reading.
 2. The emission levels that are 20dB below the official limit are not reported.

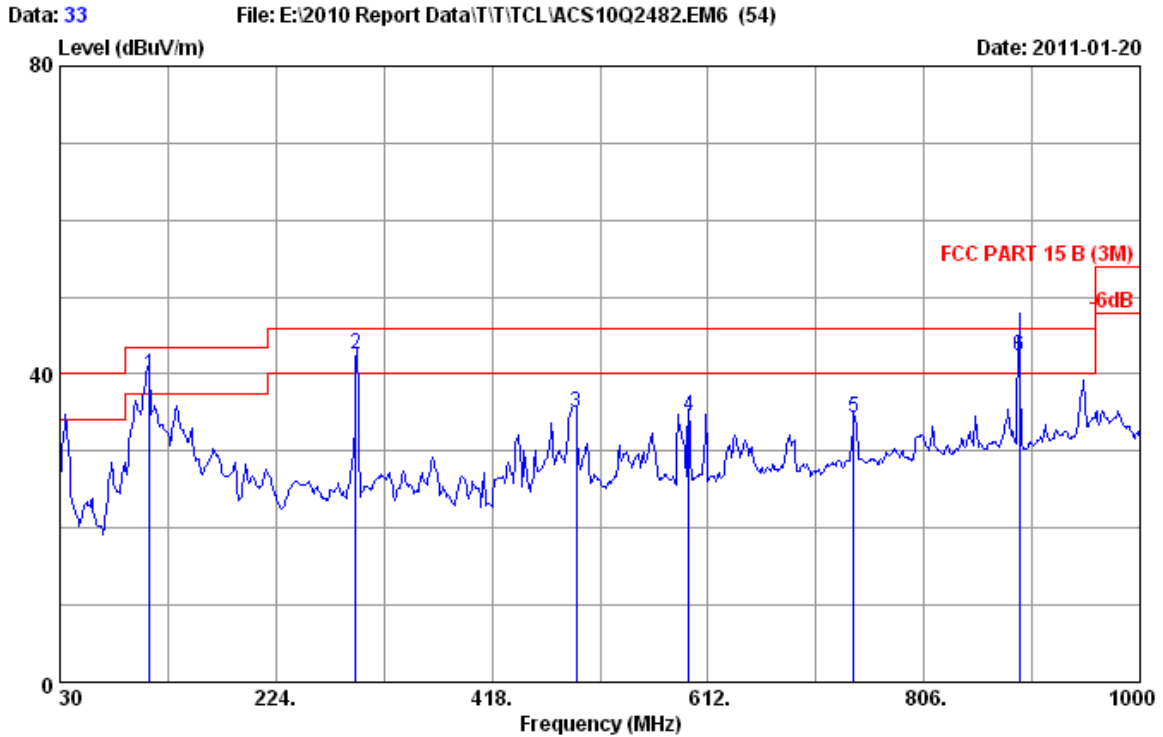

Site no. : 3m Chamber Data no. : 33
 Dis. / Ant. : 3m 2010 CBL6111C Ant. pol. : VERTICAL
 Limit : FCC PART 15 B (3M)
 Env. / Ins. : 24°C/56% Engineer : Victory
 EUT : LED TV M/N:LE32HDD20
 Power rating : AC 120V/60Hz
 Test Mode : PC MODE
 Running "H" Pattern And 1KHz Playing
 HDMI1:1080P

No.	Freq. (MHz)	Ant. Factor (dB/m)	Cable Loss (dB)	Reading (dBuV)	Emission Level (dBuV/m)	Limits (dBuV/m)	Margin (dB)	Remark
1	110.350	11.45	1.12	27.30	39.87	43.50	3.63	QP
2	295.410	13.70	2.46	26.30	42.46	46.00	3.54	QP
3	493.660	18.24	3.51	13.17	34.92	46.00	11.08	QP
4	594.540	19.85	4.09	10.57	34.51	46.00	11.49	QP
5	742.950	21.86	4.67	7.75	34.28	46.00	11.72	QP
6	891.540	22.89	5.17	14.20	42.26	46.00	3.74	QP

Remarks: 1. Emission Level= Antenna Factor + Cable Loss + Reading.
 2. The emission levels that are 20dB below the official limit are not reported.

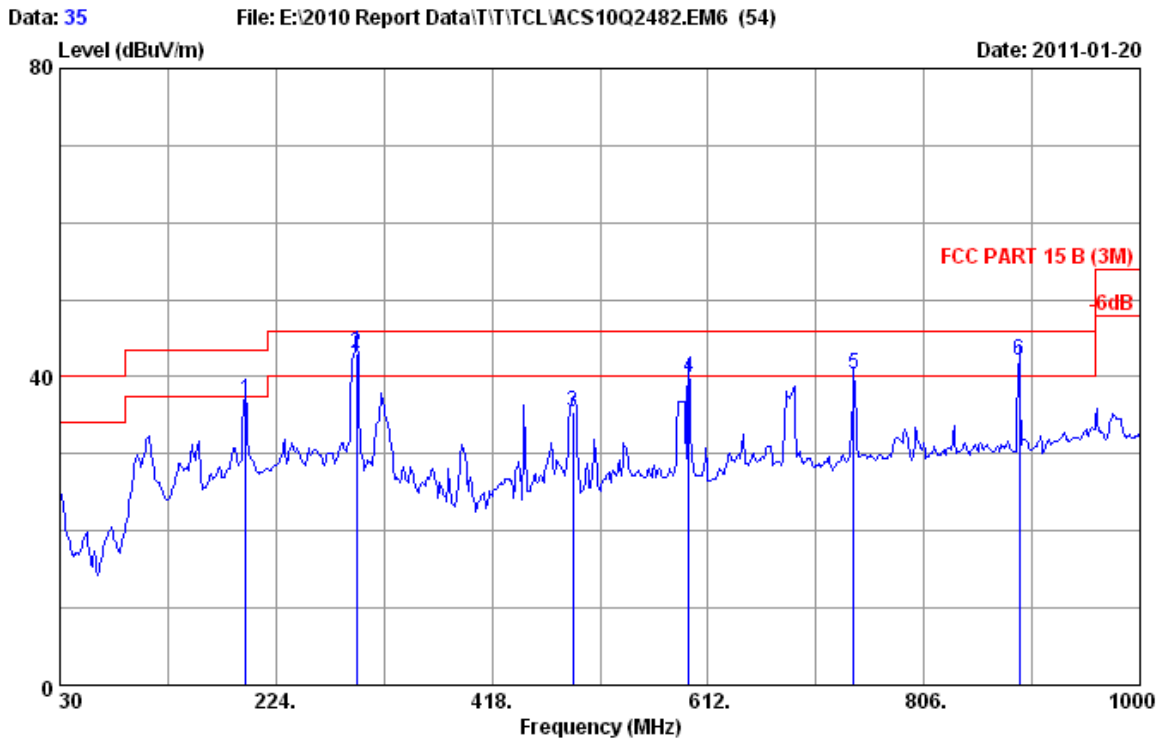

Site no. : 3m Chamber Data no. : 35
 Dis. / Ant. : 3m 2010 CBL6111C Ant. pol. : HORIZONTAL
 Limit : FCC PART 15 B (3M)
 Env. / Ins. : 24°C/56% Engineer : Victory
 EUT : LED TV M/N:LE32HDD20
 Power rating : AC 120V/60Hz
 Test Mode : PC MODE
 Running "H" Pattern And 1KHz Playing
 HDMI2:1080P

No.	Freq. (MHz)	Ant. Factor (dB/m)	Cable Loss (dB)	Reading (dBuV)	Emission Level (dBuV/m)	Limits (dBuV/m)	Margin (dB)	Remark
1	196.840	9.82	1.69	25.52	37.03	43.50	6.47	QP
2	296.750	13.70	2.46	26.77	42.93	46.00	3.07	QP
3	490.750	18.21	3.49	13.77	35.47	46.00	10.53	QP
4	594.540	19.85	4.09	15.87	39.81	46.00	6.19	QP
5	742.950	21.86	4.67	13.78	40.31	46.00	5.69	QP
6	891.360	22.89	5.17	14.01	42.07	46.00	3.93	QP

Remarks: 1. Emission Level= Antenna Factor + Cable Loss + Reading.
 2. The emission levels that are 20dB below the official limit are not reported.

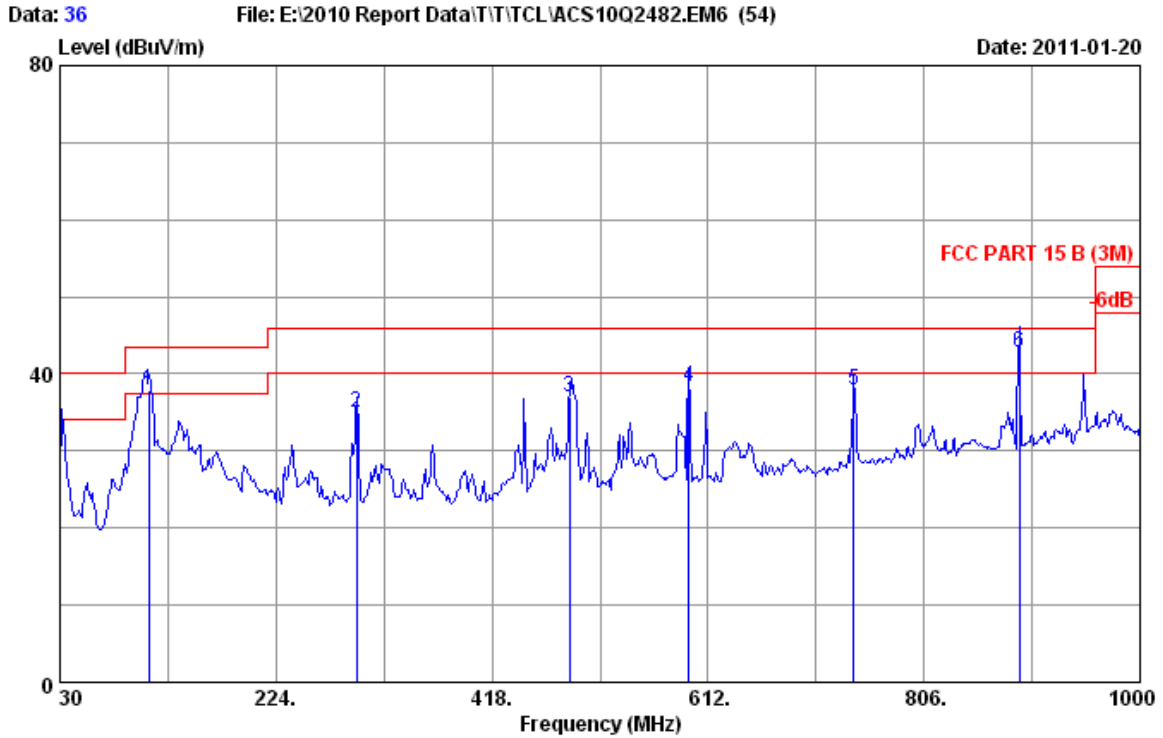

Site no. : 3m Chamber Data no. : 36
 Dis. / Ant. : 3m 2010 CBL6111C Ant. pol. : VERTICAL
 Limit : FCC PART 15 B (3M)
 Env. / Ins. : 24°C/56% Engineer : Victory
 EUT : LED TV M/N:LE32HDD20
 Power rating : AC 120V/60Hz
 Test Mode : PC MODE
 Running "H" Pattern And 1KHz Playing
 HDMI2:1080P

No.	Freq. (MHz)	Ant. Factor (dB/m)	Cable Loss (dB)	Reading (dBUV)	Emission Level (dBUV/m)	Limits (dBUV/m)	Margin (dB)	Remark
1	109.540	11.40	1.12	25.42	37.94	43.50	5.56	QP
2	296.750	13.70	2.46	18.73	34.89	46.00	11.11	QP
3	487.840	18.18	3.47	15.42	37.07	46.00	8.93	QP
4	594.540	19.85	4.09	14.48	38.42	46.00	7.58	QP
5	742.950	21.86	4.67	11.31	37.84	46.00	8.16	QP
6	891.360	22.89	5.17	14.70	42.76	46.00	3.24	QP

Remarks: 1. Emission Level= Antenna Factor + Cable Loss + Reading.
 2. The emission levels that are 20dB below the official limit are not reported.

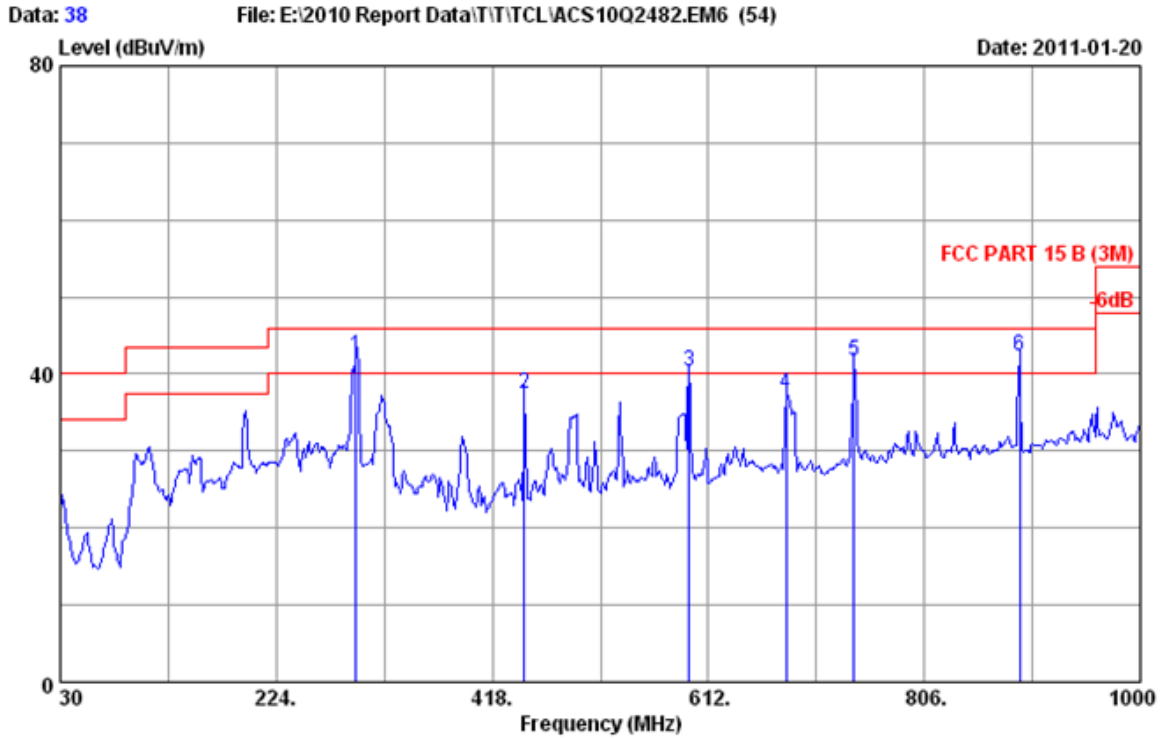

Site no.	: 3m Chamber	Data no.	: 38
Dis. / Ant.	: 3m 2010 CBL6111C	Ant. pol.	: HORIZONTAL
Limit	: FCC PART 15 B (3M)	Engineer	: Victory
Env. / Ins.	: 24°C/56%		
EUT	: LED TV M/N:LE32HDD20		
Power rating	: AC 120V/60Hz		
Test Mode	: PC MODE		
	Running "H" Pattern And 1KHz Playing		
	HDMI3:1080P		

No.	Freq. (MHz)	Ant. Factor (dB/m)	Cable Loss (dB)	Reading (dBUV)	Emission Level (dBUV/m)	Limits (dBUV/m)	Margin (dB)	Remark
1	295.780	13.70	2.46	26.15	42.31	46.00	3.69	QP
2	447.100	17.06	3.21	17.27	37.54	46.00	8.46	QP
3	594.540	19.85	4.09	16.32	40.26	46.00	5.74	QP
4	681.840	20.72	4.43	12.21	37.36	46.00	8.64	QP
5	742.950	21.86	4.67	15.20	41.73	46.00	4.27	QP
6	891.360	22.89	5.17	14.19	42.25	46.00	3.75	QP

Remarks: 1. Emission Level= Antenna Factor + Cable Loss + Reading.
 2. The emission levels that are 20dB below the official limit are not reported.

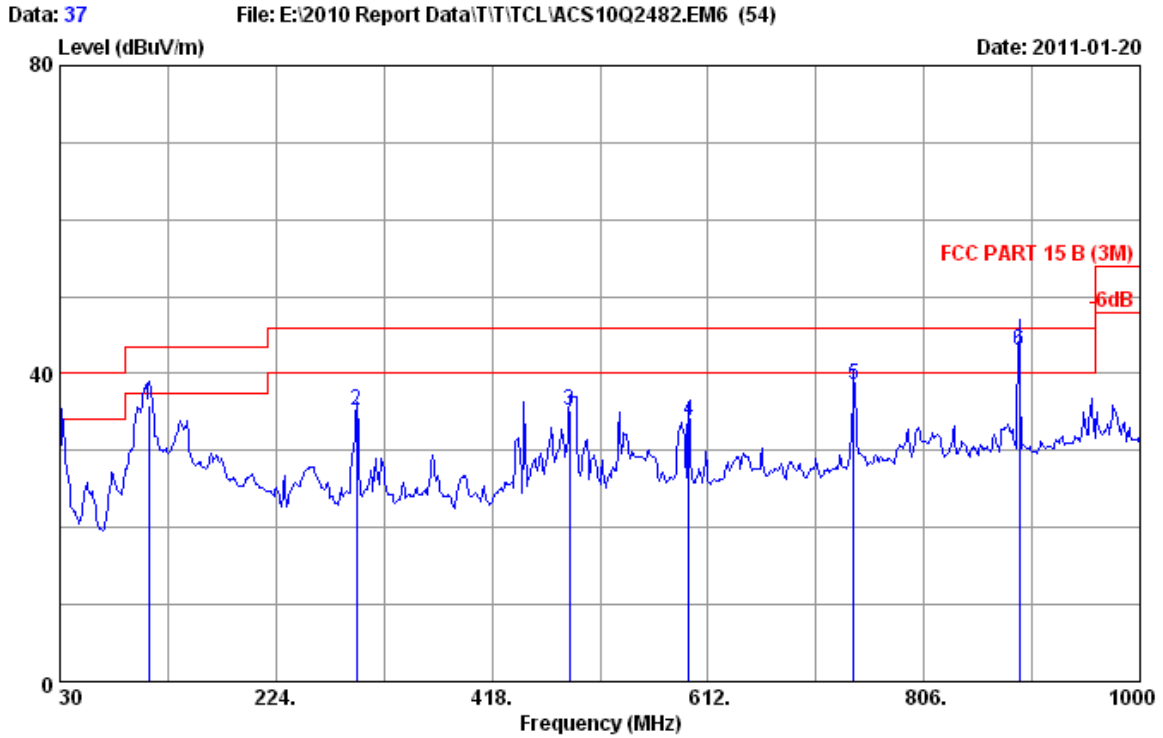

Site no. : 3m Chamber Data no. : 37
 Dis. / Ant. : 3m 2010 CBL6111C Ant. pol. : VERTICAL
 Limit : FCC PART 15 B (3M)
 Env. / Ins. : 24°C/56% Engineer : Victory
 EUT : LED TV M/N:LE32HDD20
 Power rating : AC 120V/60Hz
 Test Mode : PC MODE
 Running "H" Pattern And 1KHz Playing
 HDMI3:1080P

No.	Freq. (MHz)	Ant. Factor (dB/m)	Cable Loss (dB)	Reading (dBuV)	Emission Level (dBuV/m)	Limits (dBuV/m)	Margin (dB)	Remark
1	109.540	11.40	1.12	23.39	35.91	43.50	7.59	QP
2	296.750	13.70	2.46	19.06	35.22	46.00	10.78	QP
3	487.840	18.18	3.47	13.53	35.18	46.00	10.82	QP
4	594.540	19.85	4.09	9.91	33.85	46.00	12.15	QP
5	742.950	21.86	4.67	12.00	38.53	46.00	7.47	QP
6	891.360	22.89	5.17	14.94	43.00	46.00	3.00	QP

Remarks: 1. Emission Level= Antenna Factor + Cable Loss + Reading.
 2. The emission levels that are 20dB below the official limit are not reported.

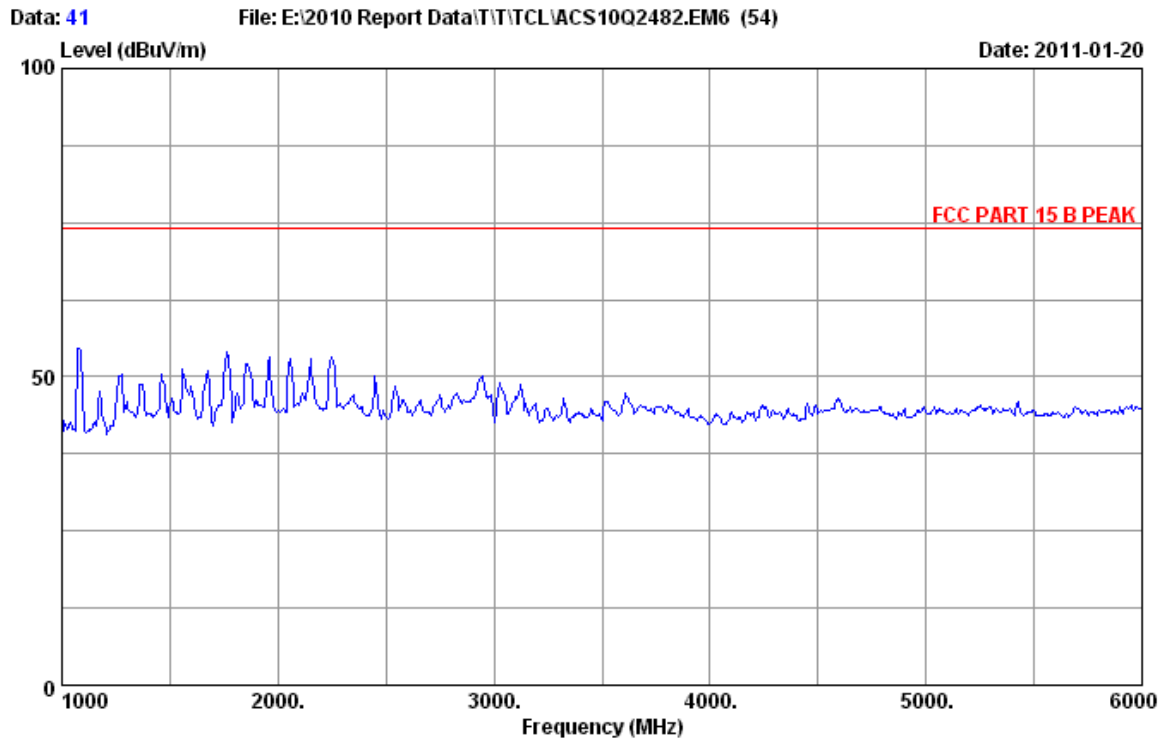

Site no.	: 3m Chamber	Data no.	: 41
Dis. / Ant.	: 3m 2009 3115	Ant. pol.	: HORIZONTAL
Limit	: FCC PART 15 B PEAK		
Env. / Ins.	: 24°C/56%	Engineer	: Victory
EUT	: LED TV M/N:LE32HDD20		
Power Rating	: AC 120V/60Hz		
Test Mode	: PC MODE		
	Running "H" Pattern And 1KHz Playing		
	VGA:1024*768@60Hz		

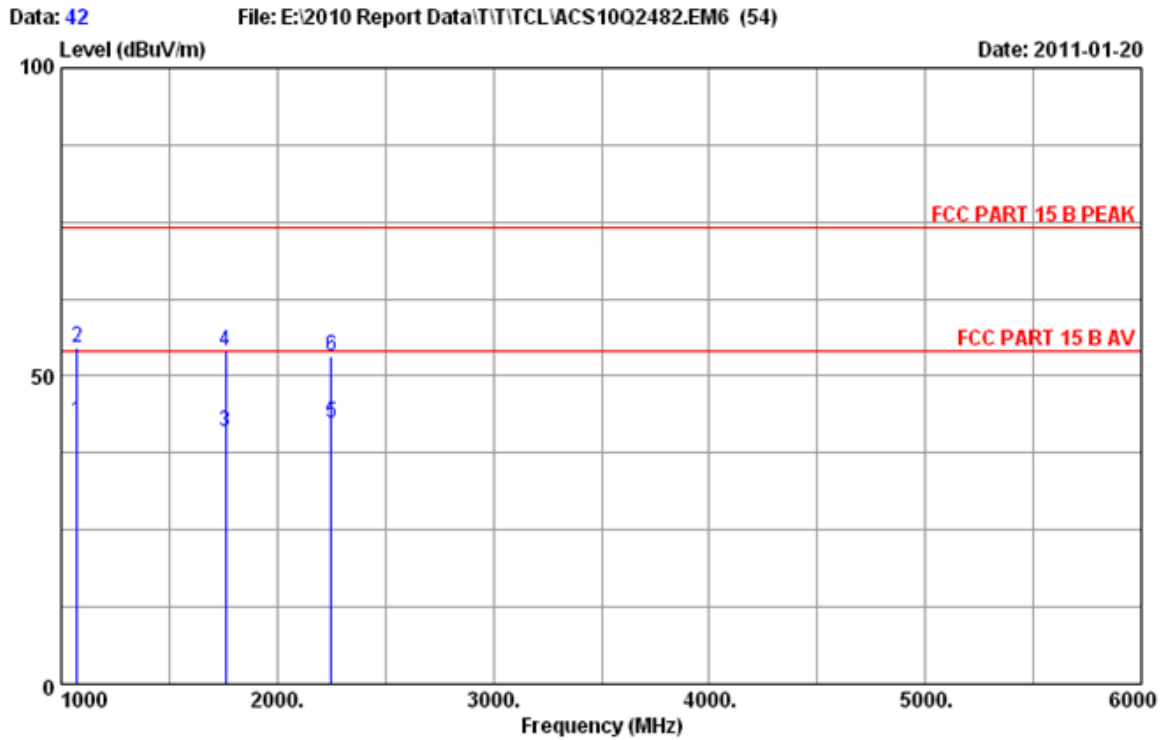

Site no. : 3m Chamber Data no. : 42
 Dis. / Ant. : 3m 2009 3115 Ant. pol. : HORIZONTAL
 Limit : FCC PART 15 B PEAK
 Env. / Ins. : 24°C/56% Engineer : Victory
 EUT : LED TV M/N:LE32HDD20
 Power Rating : AC 120V/60Hz
 Test Mode : PC MODE
 Running "H" Pattern And 1KHz Playing
 VGA:1024*768@60Hz

No.	Freq. (MHz)	Ant. Factor (dB/m)	Cable Loss (dB)	AMP factor (dBuV)	Reading (dBuV/m)	Emission Level (dBuV/m)	Limits (dB)	Margin (dB)	Remark
1	1075.000	25.37	4.05	36.51	49.80	42.71	54.00	11.29	Average
2	1075.000	25.37	4.05	36.51	61.80	54.71	74.00	19.29	Peak
3	1760.000	25.79	5.00	34.75	45.03	41.07	54.00	12.93	Average
4	1760.000	25.79	5.00	34.75	58.03	54.07	74.00	19.93	Peak
5	2250.000	27.85	5.67	33.97	42.75	42.30	54.00	11.70	Average
6	2250.000	27.85	5.67	33.97	53.75	53.30	74.00	20.70	Peak

Remarks: 1. Emission Level= Antenna Factor + Cable Loss + Reading - Amp Factor
 2. The emission levels that are 20dB below the official limit are not reported.

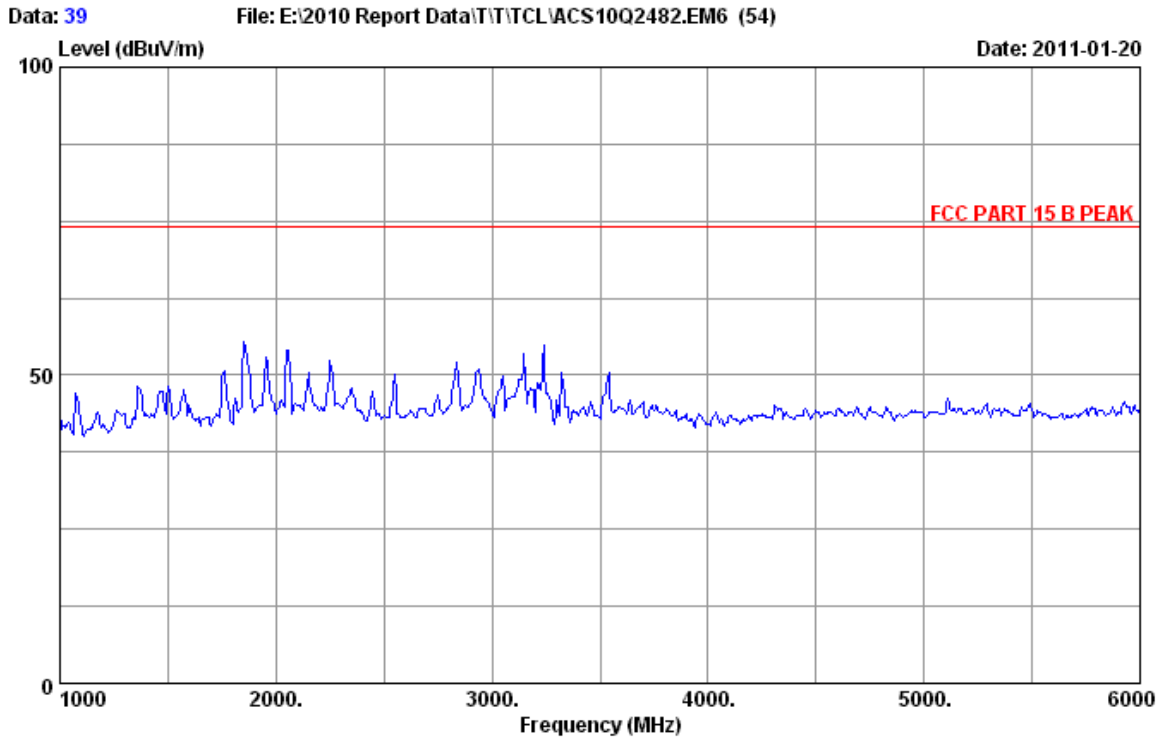

Site no. : 3m Chamber Data no. : 39
Dis. / Ant. : 3m 2009 3115 Ant. pol. : VERTICAL
Limit : FCC PART 15 B PEAK
Env. / Ins. : 24°C/56% Engineer : Victory
EUT : LED TV M/N:LE32HDD20
Power Rating : AC 120V/60Hz
Test Mode : PC MODE
Running "H" Pattern And 1KHz Playing
VGA:1024*768@60Hz

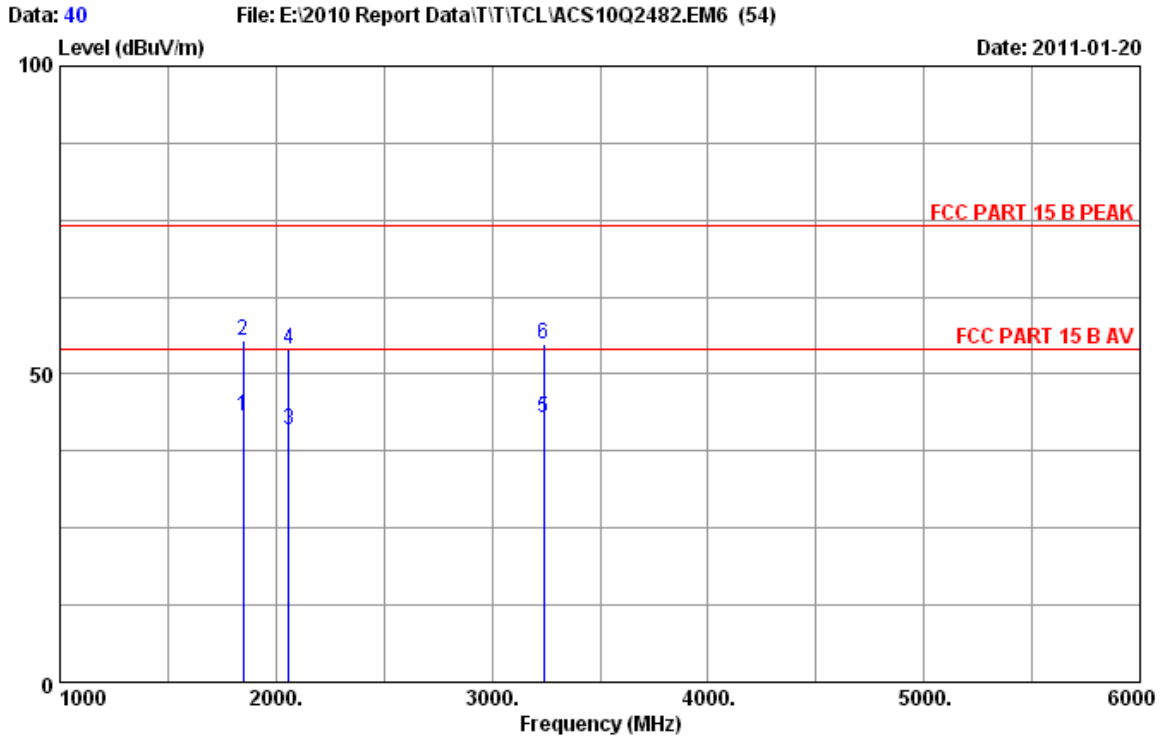

Site no. : 3m Chamber Data no. : 40
 Dis. / Ant. : 3m 2009 3115 Ant. pol. : VERTICAL
 Limit : FCC PART 15 B PEAK
 Env. / Ins. : 24°C/56% Engineer : Victory
 EUT : LED TV M/N:LE32HDD20
 Power Rating : AC 120V/60Hz
 Test Mode : PC MODE
 Running "H" Pattern And 1KHz Playing
 VGA:1024*768@60Hz

No.	Freq. (MHz)	Ant. Factor (dB/m)	Cable Loss (dB)	AMP factor (dBuV)	Reading (dBuV/m)	Emission Level (dBuV/m)	Limits (dB)	Margin (dB)	Remark
1	1850.000	25.97	5.12	34.49	46.70	43.30	54.00	10.70	Average
2	1850.000	25.97	5.12	34.49	58.70	55.30	74.00	18.70	Peak
3	2060.000	26.61	5.39	34.07	43.15	41.08	54.00	12.92	Average
4	2060.000	26.61	5.39	34.07	56.15	54.08	74.00	19.92	Peak
5	3240.000	31.09	6.88	33.47	38.34	42.84	54.00	11.16	Average
6	3240.000	31.09	6.88	33.47	50.34	54.84	74.00	19.16	Peak

Remarks: 1. Emission Level= Antenna Factor + Cable Loss + Reading - Amp Factor
 2. The emission levels that are 20dB below the official limit are not reported.

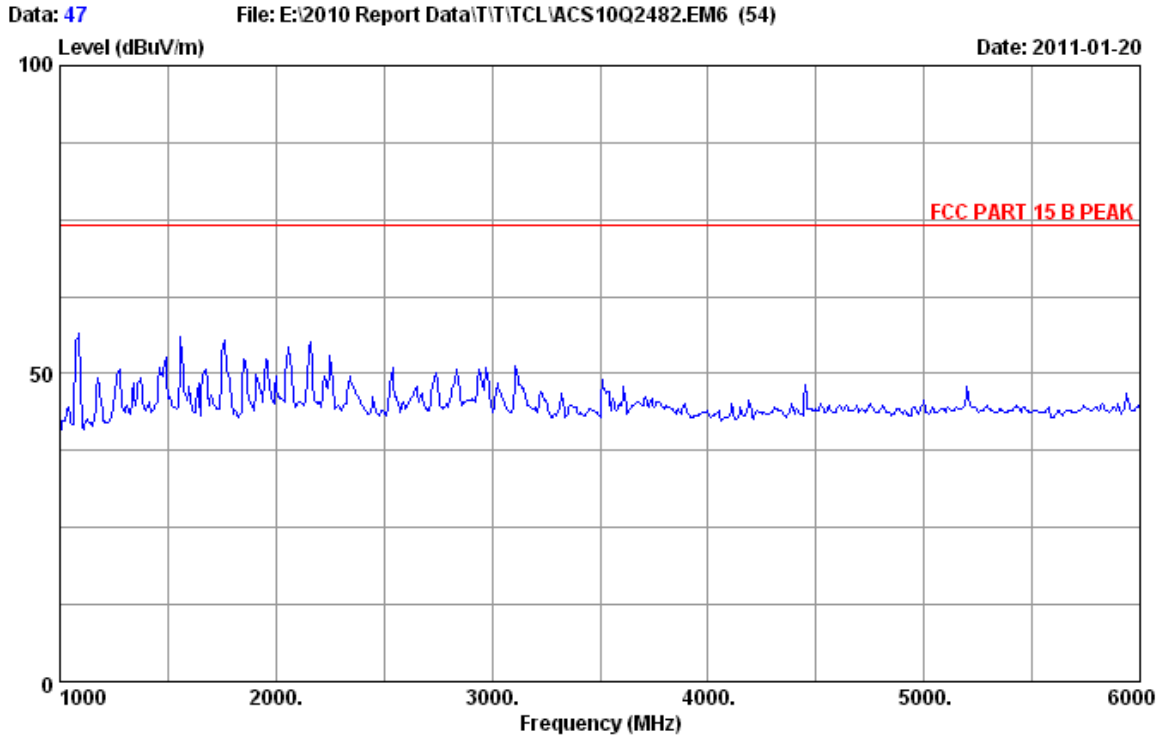

Site no. : 3m Chamber Data no. : 47
Dis. / Ant. : 3m 2009 3115 Ant. pol. : HORIZONTAL
Limit : FCC PART 15 B PEAK
Env. / Ins. : 24°C/56% Engineer : Victory
EUT : LED TV M/N:LE32HDD20
Power Rating : AC 120V/60Hz
Test Mode : PC MODE
Running "H" Pattern And 1KHz Playing
HDMI1:1080P

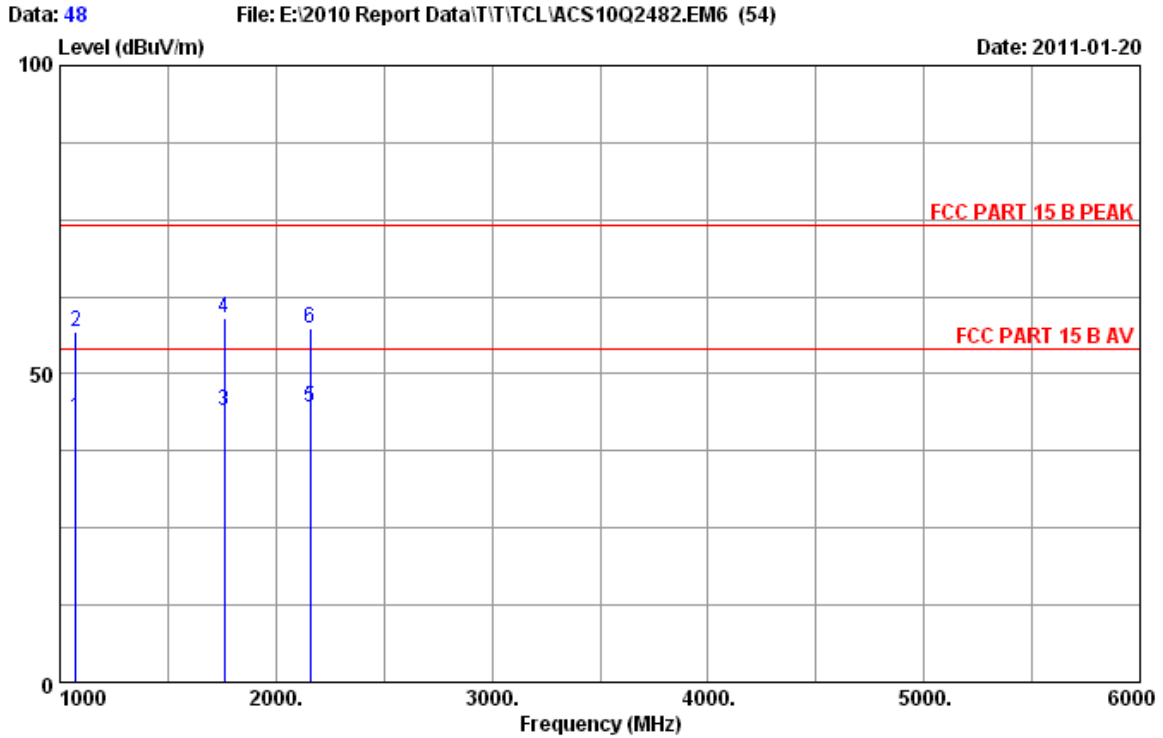

Site no. : 3m Chamber Data no. : 48
 Dis. / Ant. : 3m 2009 3115 Ant. pol. : HORIZONTAL
 Limit : FCC PART 15 B PEAK
 Env. / Ins. : 24°C/56% Engineer : Victory
 EUT : LED TV M/N:LE32HDD20
 Power Rating : AC 120V/60Hz
 Test Mode : PC MODE
 Running "H" Pattern And 1KHz Playing
 HDMI1:1080P

No.	Freq. (MHz)	Ant. Factor (dB/m)	Cable Loss (dB)	AMP factor (dBuV)	Reading (dBuV/m)	Emission Level (dBuV/m)	Limits (dB)	Margin (dB)	Remark
1	1075.000	25.37	4.05	36.51	50.05	42.96	54.00	11.04	Average
2	1075.000	25.37	4.05	36.51	64.05	56.96	74.00	17.04	Peak
3	1760.000	25.79	5.00	34.75	48.09	44.13	54.00	9.87	Average
4	1760.000	25.79	5.00	34.75	63.09	59.13	74.00	14.87	Peak
5	2160.000	27.23	5.53	34.02	45.70	44.44	54.00	9.56	Average
6	2160.000	27.23	5.53	34.02	58.70	57.44	74.00	16.56	Peak

Remarks: 1. Emission Level= Antenna Factor + Cable Loss + Reading - Amp Factor
 2. The emission levels that are 20dB below the official limit are not reported.

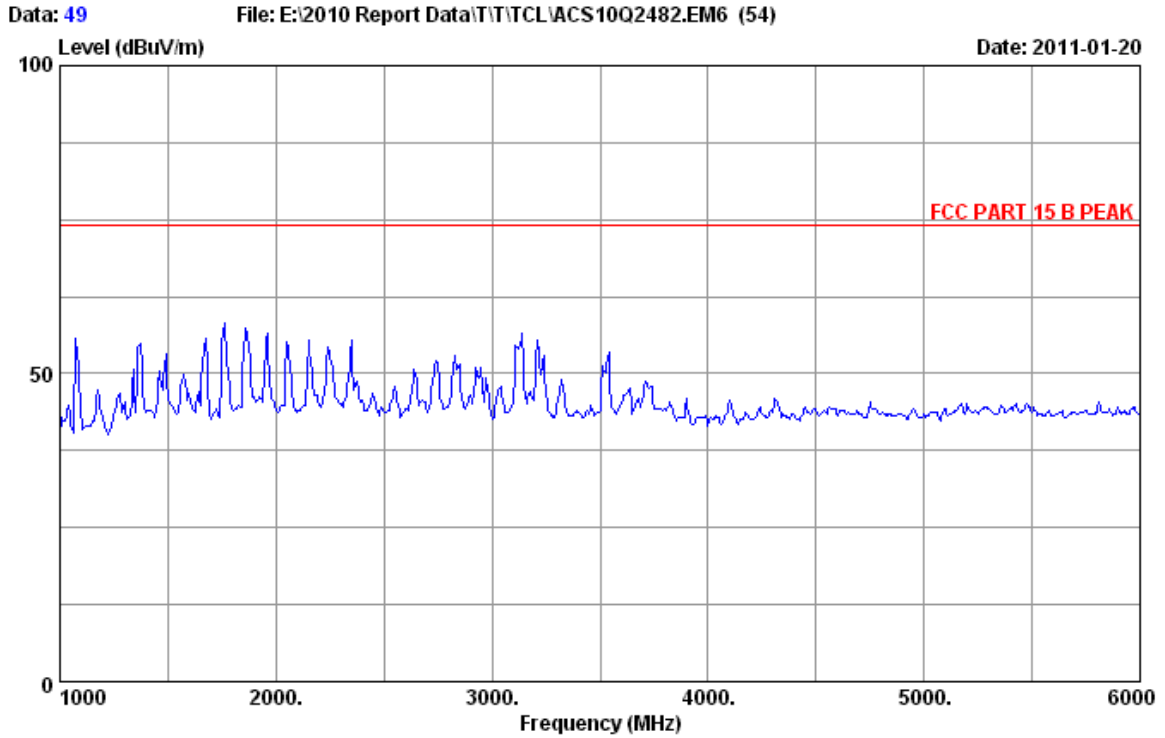

Site no. : 3m Chamber Data no. : 49
Dis. / Ant. : 3m 2009 3115 Ant. pol. : VERTICAL
Limit : FCC PART 15 B PEAK
Env. / Ins. : 24°C/56% Engineer : Victory
EUT : LED TV M/N:LE32HDD20
Power Rating : AC 120V/60Hz
Test Mode : PC MODE
Running "H" Pattern And 1KHz Playing
HDMI1:1080P



Site no. : 3m Chamber Data no. : 50
 Dis. / Ant. : 3m 2009 3115 Ant. pol. : VERTICAL
 Limit : FCC PART 15 B PEAK
 Env. / Ins. : 24°C/56% Engineer : Victory
 EUT : LED TV M/N:LE32HDD20
 Power Rating : AC 120V/60Hz
 Test Mode : PC MODE
 Running "H" Pattern And 1KHz Playing
 HDMI1:1080P

No.	Freq. (MHz)	Ant. Factor (dB/m)	Cable Loss (dB)	AMP factor (dBUV)	Reading (dBUV/m)	Emission Level (dBUV/m)	Limits (dB)	Margin (dB)	Remark
1	1075.000	25.37	4.05	36.51	50.86	43.77	54.00	10.23	Average
2	1075.000	25.37	4.05	36.51	62.86	55.77	74.00	18.23	Peak
3	1760.000	25.79	5.00	34.75	48.31	44.35	54.00	9.65	Average
4	1760.000	25.79	5.00	34.75	62.31	58.35	74.00	15.65	Peak
5	3140.000	31.01	6.80	33.52	38.33	42.62	54.00	11.38	Average
6	3140.000	31.01	6.80	33.52	52.33	56.62	74.00	17.38	Peak

Remarks: 1. Emission Level= Antenna Factor + Cable Loss + Reading - Amp Factor
 2. The emission levels that are 20dB below the official limit are not reported.

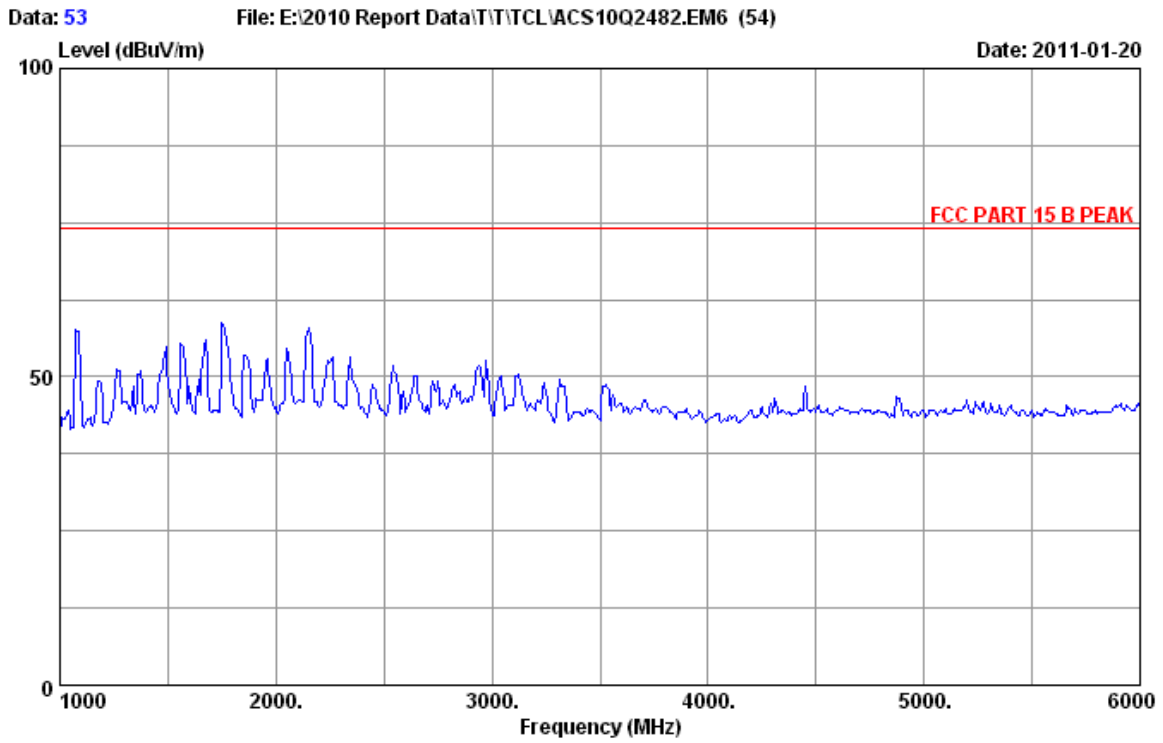

Site no.	: 3m Chamber	Data no.	: 53
Dis. / Ant.	: 3m 2009 3115	Ant. pol.	: HORIZONTAL
Limit	: FCC PART 15 B PEAK		
Env. / Ins.	: 24°C/56%	Engineer	: Victory
EUT	: LED TV M/N:LE32HDD20		
Power Rating	: AC 120V/60Hz		
Test Mode	: PC MODE		
	Running "H" Pattern And 1KHz Playing		
	HDMI2:1080P		

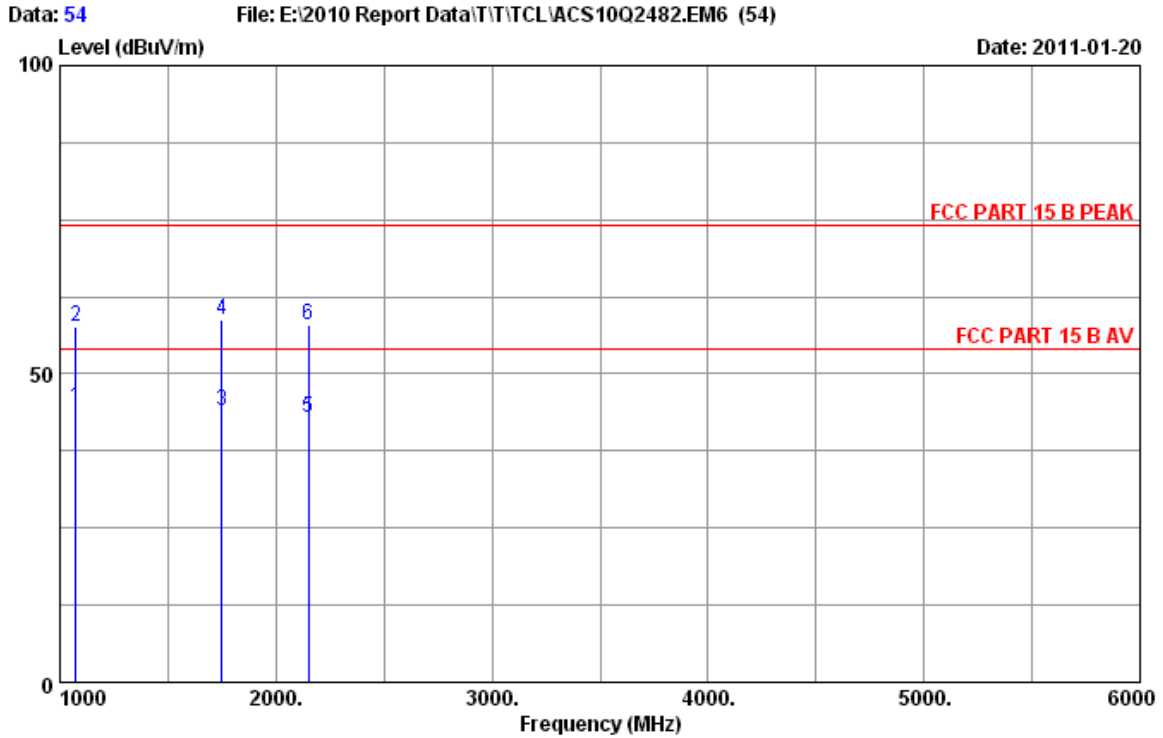

Site no. : 3m Chamber Data no. : 54
 Dis. / Ant. : 3m 2009 3115 Ant. pol. : HORIZONTAL
 Limit : FCC PART 15 B PEAK
 Env. / Ins. : 24°C/56% Engineer : Victory
 EUT : LED TV M/N:LE32HDD20
 Power Rating : AC 120V/60Hz
 Test Mode : PC MODE
 Running "H" Pattern And 1KHz Playing
 HDMI2:1080P

No.	Freq. (MHz)	Ant. Factor (dB/m)	Cable Loss (dB)	AMP factor (dBuV)	Reading (dBuV/m)	Emission Level (dBuV/m)	Limits (dB)	Margin (dB)	Remark
1	1075.000	25.37	4.05	36.51	51.61	44.52	54.00	9.48	Average
2	1075.000	25.37	4.05	36.51	64.61	57.52	74.00	16.48	Peak
3	1750.000	25.75	4.98	34.75	47.90	43.88	54.00	10.12	Average
4	1750.000	25.75	4.98	34.75	62.90	58.88	74.00	15.12	Peak
5	2150.000	27.23	5.53	34.02	44.11	42.85	54.00	11.15	Average
6	2150.000	27.23	5.53	34.02	59.11	57.85	74.00	16.15	Peak

Remarks: 1. Emission Level= Antenna Factor + Cable Loss + Reading - Amp Factor
 2. The emission levels that are 20dB below the official limit are not reported.

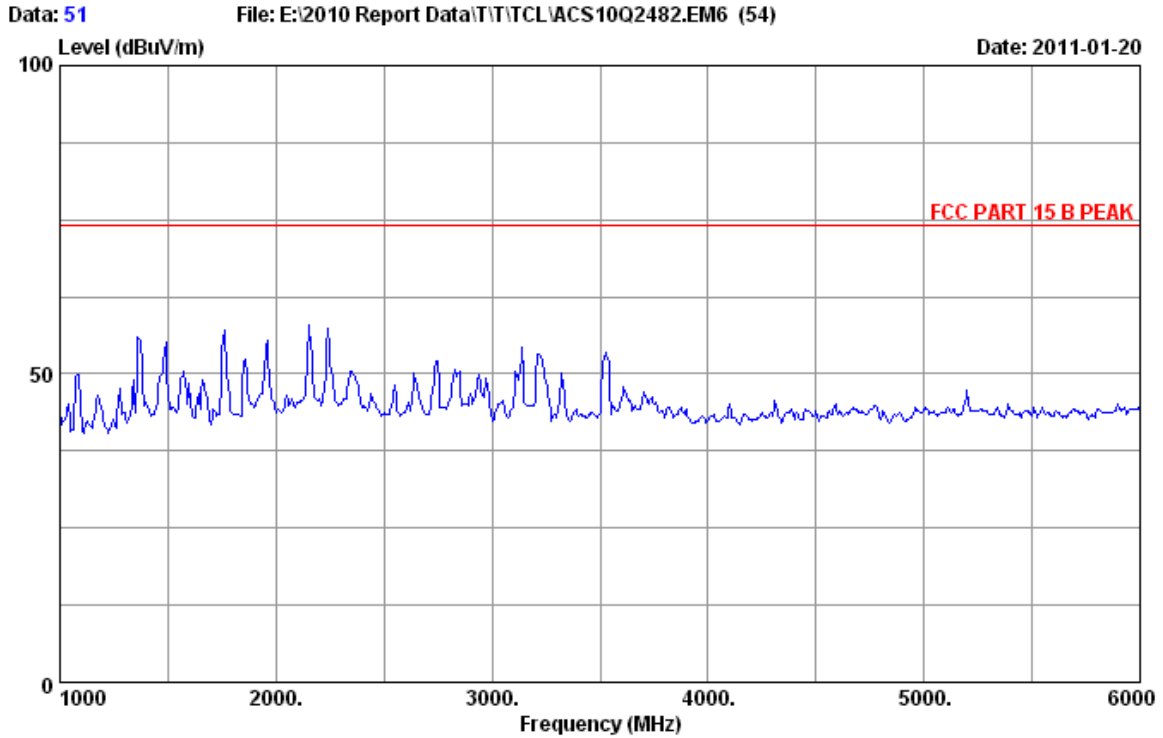

Site no.	: 3m Chamber	Data no.	: 51
Dis. / Ant.	: 3m 2009 3115	Ant. pol.	: VERTICAL
Limit	: FCC PART 15 B PEAK	Engineer	: Victory
Env. / Ins.	: 24°C/56%		
EUT	: LED TV M/N:LE32HDD20		
Power Rating	: AC 120V/60Hz		
Test Mode	: PC MODE		
	Running "H" Pattern And 1KHz Playing		
	HDMI2:1080P		

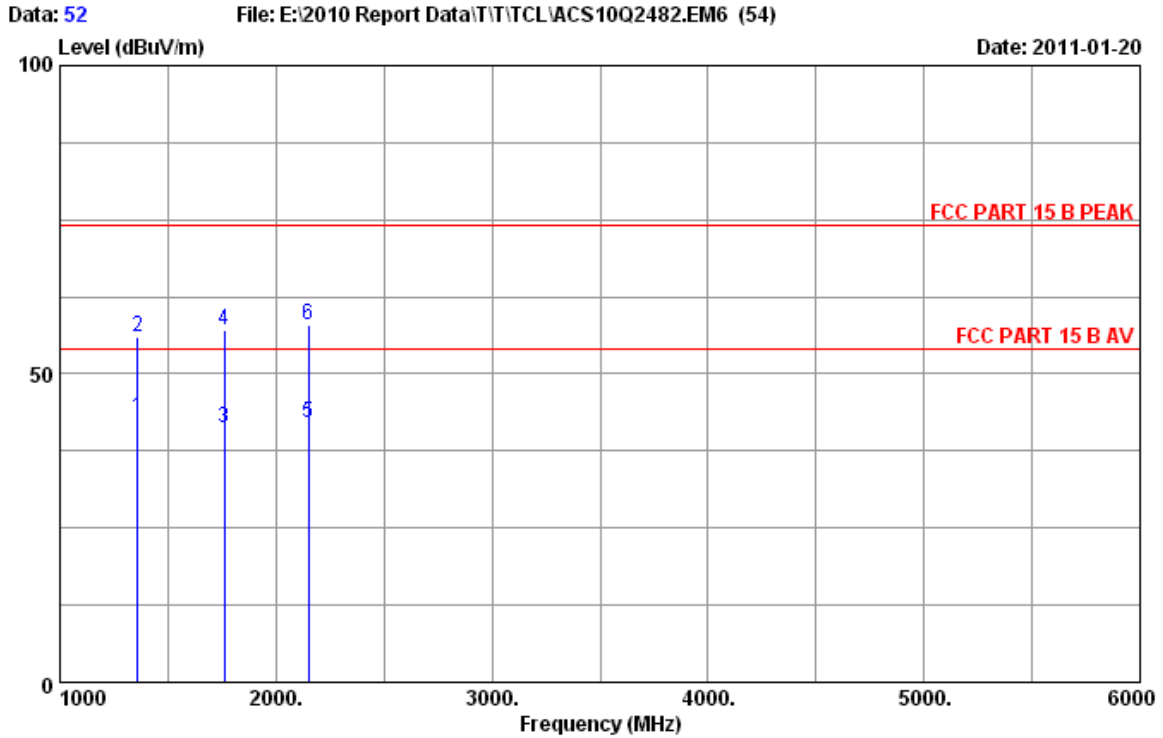

Site no. : 3m Chamber Data no. : 52
 Dis. / Ant. : 3m 2009 3115 Ant. pol. : VERTICAL
 Limit : FCC PART 15 B PEAK
 Env. / Ins. : 24°C/56% Engineer : Victory
 EUT : LED TV M/N:LE32HDD20
 Power Rating : AC 120V/60Hz
 Test Mode : PC MODE
 Running "H" Pattern And 1KHz Playing
 HDMI2:1080P

No.	Freq. (MHz)	Ant. Factor (dB/m)	Cable Loss (dB)	AMP factor (dBuV)	Reading (dBuV/m)	Emission Level (dBuV/m)	Limits (dB)	Margin (dB)	Remark
1	1360.000	25.26	4.45	35.79	48.98	42.90	54.00	11.10	Average
2	1360.000	25.26	4.45	35.79	61.98	55.90	74.00	18.10	Peak
3	1760.000	25.79	5.00	34.75	45.10	41.14	54.00	12.86	Average
4	1760.000	25.79	5.00	34.75	61.10	57.14	74.00	16.86	Peak
5	2150.000	27.23	5.53	34.02	43.29	42.03	54.00	11.97	Average
6	2150.000	27.23	5.53	34.02	59.29	58.03	74.00	15.97	Peak

Remarks: 1. Emission Level= Antenna Factor + Cable Loss + Reading - Amp Factor
 2. The emission levels that are 20dB below the official limit are not reported.

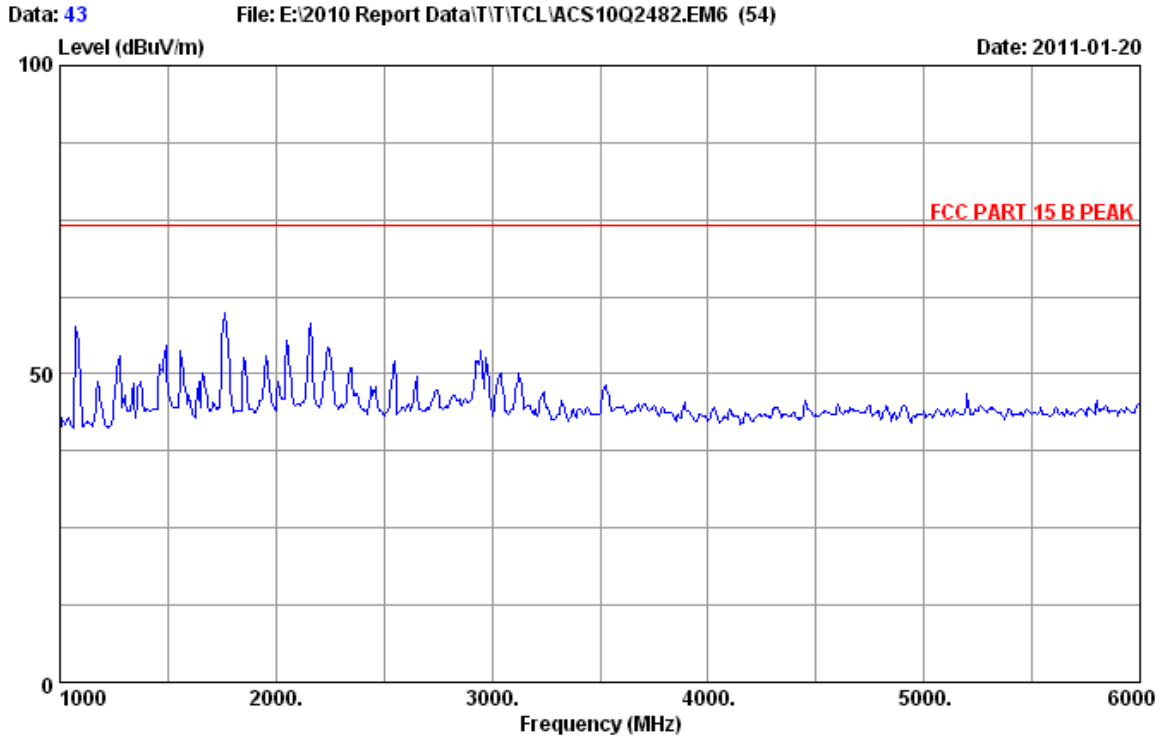

Site no. : 3m Chamber Data no. : 43
Dis. / Ant. : 3m 2009 3115 Ant. pol. : HORIZONTAL
Limit : FCC PART 15 B PEAK
Env. / Ins. : 24°C/56% Engineer : Victory
EUT : LED TV M/N:LE32HDD20
Power Rating : AC 120V/60Hz
Test Mode : PC MODE
Runnning "H" Pattern And 1KHz Playing
HDMI3:1080P

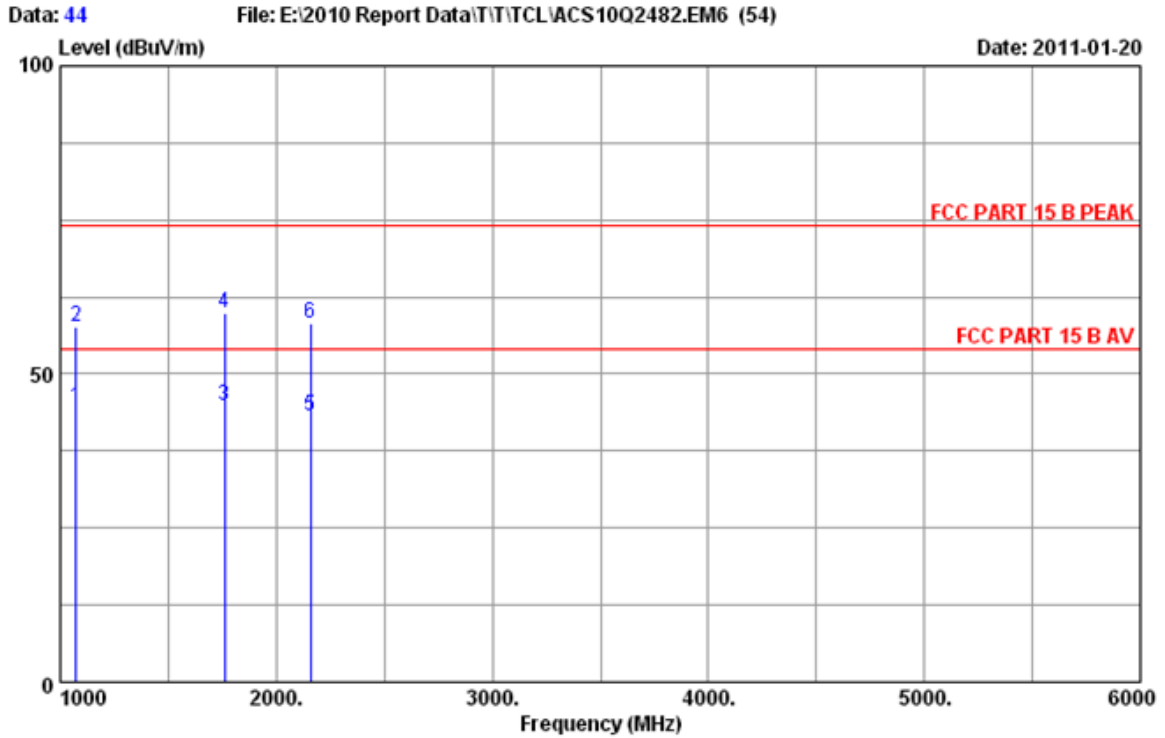

Site no. : 3m Chamber Data no. : 44
 Dis. / Ant. : 3m 2009 3115 Ant. pol. : HORIZONTAL
 Limit : FCC PART 15 B PEAK
 Env. / Ins. : 24°C/56% Engineer : Victory
 EUT : LED TV M/N:LE32HDD20
 Power Rating : AC 120V/60Hz
 Test Mode : PC MODE
 Running "H" Pattern And 1KHz Playing
 HDMI3:1080P

No.	Freq. (MHz)	Ant. Factor (dB/m)	Cable Loss (dB)	AMP factor (dBuV)	Reading (dBuV/m)	Emission Level (dBuV/m)	Limits (dB)	Margin (dB)	Remark
1	1075.000	25.37	4.05	36.51	51.69	44.60	54.00	9.40	Average
2	1075.000	25.37	4.05	36.51	64.69	57.60	74.00	16.40	Peak
3	1760.000	25.79	5.00	34.75	48.72	44.76	54.00	9.24	Average
4	1760.000	25.79	5.00	34.75	63.72	59.76	74.00	14.24	Peak
5	2160.000	27.23	5.53	34.02	44.35	43.09	54.00	10.91	Average
6	2160.000	27.23	5.53	34.02	59.35	58.09	74.00	15.91	Peak

Remarks: 1. Emission Level= Antenna Factor + Cable Loss + Reading - Amp Factor
 2. The emission levels that are 20dB below the official limit are not reported.

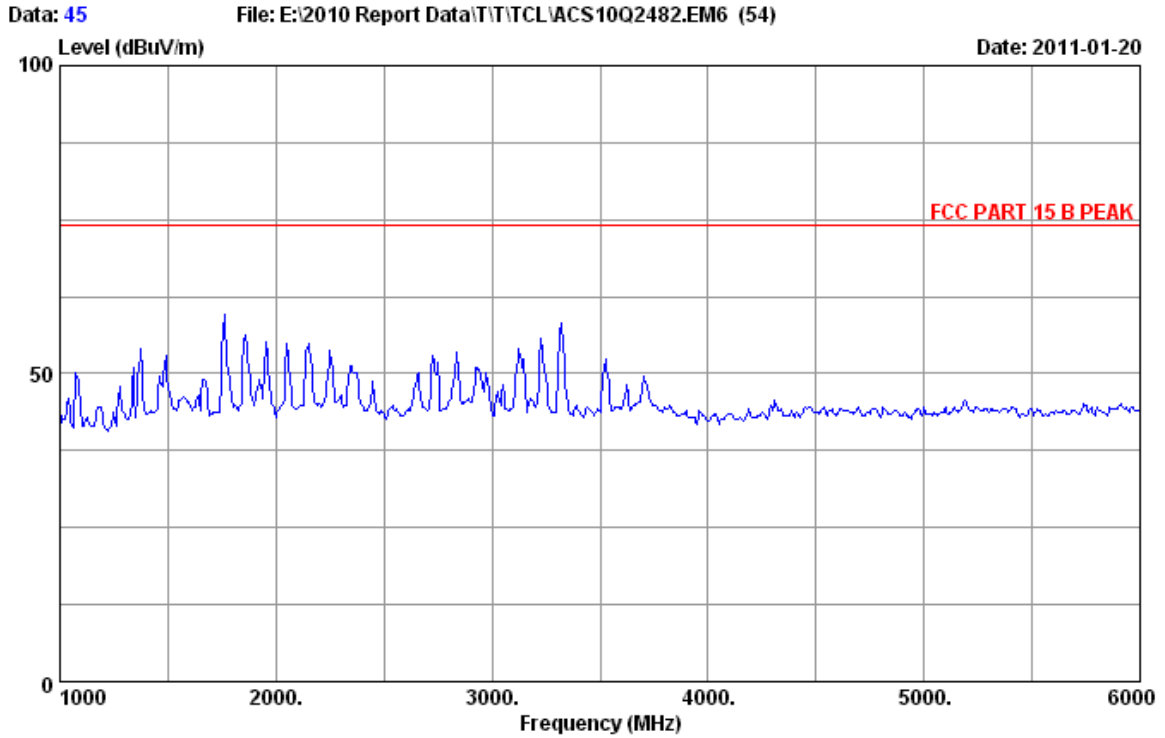

Site no. : 3m Chamber Data no. : 45
Dis. / Ant. : 3m 2009 3115 Ant. pol. : VERTICAL
Limit : FCC PART 15 B PEAK
Env. / Ins. : 24°C/56% Engineer : Victory
EUT : LED TV M/N:LE32HDD20
Power Rating : AC 120V/60Hz
Test Mode : PC MODE
Running "H" Pattern And 1KHz Playing
HDMI3:1080P

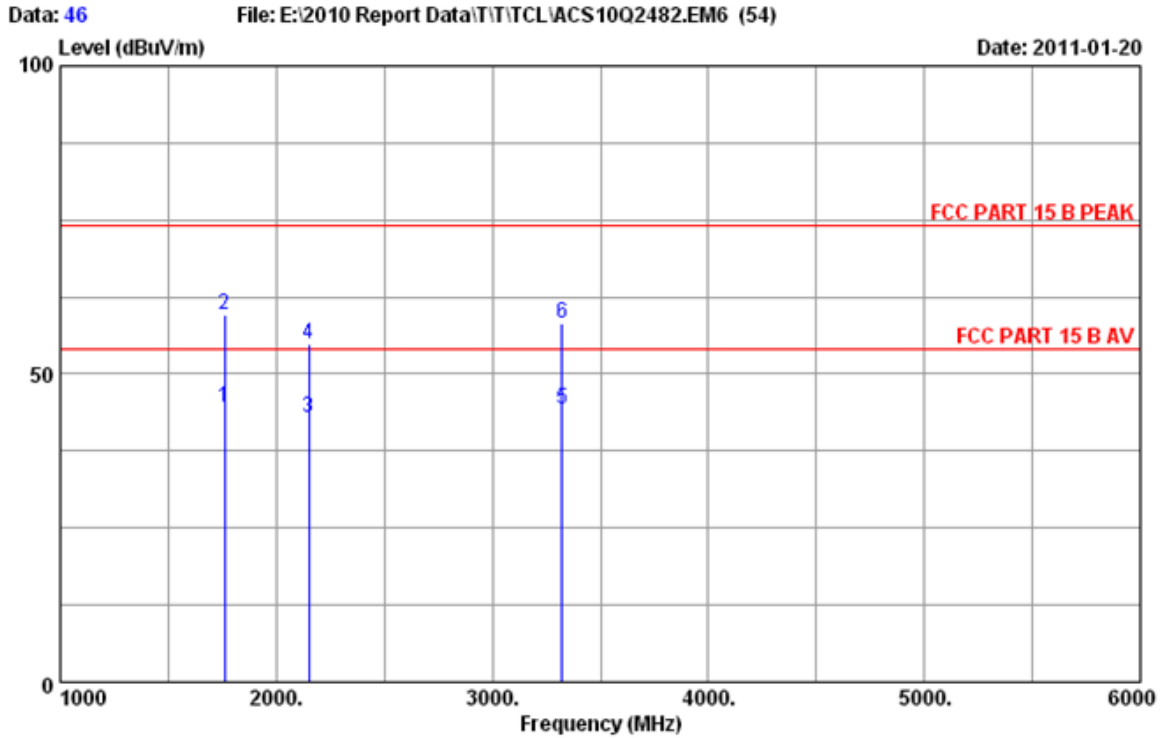

Site no. : 3m Chamber Data no. : 46
 Dis. / Ant. : 3m 2009 3115 Ant. pol. : VERTICAL
 Limit : FCC PART 15 B PEAK
 Env. / Ins. : 24°C/56% Engineer : Victory
 EUT : LED TV M/N:LE32HDD20
 Power Rating : AC 120V/60Hz
 Test Mode : PC MODE
 Running "H" Pattern And 1KHz Playing
 HDMI3:1080P

No.	Freq. (MHz)	Ant. Factor (dB/m)	Cable Loss (dB)	AMP factor (dBuV)	Reading (dBuV/m)	Emission Level (dBuV/m)	Limits (dB)	Margin (dB)	Remark
1	1760.000	25.79	5.00	34.75	48.61	44.65	54.00	9.35	Average
2	1760.000	25.79	5.00	34.75	63.61	59.65	74.00	14.35	Peak
3	2150.000	27.23	5.53	34.02	44.02	42.76	54.00	11.24	Average
4	2150.000	27.23	5.53	34.02	56.02	54.76	74.00	19.24	Peak
5	3325.000	31.16	6.94	33.44	39.49	44.15	54.00	9.85	Average
6	3325.000	31.16	6.94	33.44	53.49	58.15	74.00	15.85	Peak

Remarks: 1. Emission Level= Antenna Factor + Cable Loss + Reading - Amp Factor
 2. The emission levels that are 20dB below the official limit are not reported.