



APPLICATION OF CERTIFICATION
For

TTE Technology Inc.

LCD TV

Model Number: L40FHDF11TA

FCC ID: W8UL40FHDF11TA

Prepared for : TTE Technology Inc.
5541 W. 74th St, Indianapolis, IN 46268, U.S.A.

Prepared By: Audix Technology (Shenzhen) Co., Ltd.
No. 6, Ke Feng Rd., 52 Block,
Shenzhen Science & Industrial Park,
Nantou, Shenzhen, Guangdong, China

Tel: (0755) 26639496
Fax: (0755) 26632877

Report Number : ACS- F10115-1
Date of Test of Rev.1 : Sep.29, 2010
Date of Report of Rev.1 : Oct.19, 2010

TABLE OF CONTENTS

Description	Page
Test Report Declaration	
1. DESCRIPTION OF VERSION.....	1-1
2. SUMMARY OF STANDARDS AND RESULTS	2-1
2.1. Description of Standards and Results	2-1
3. GENERAL INFORMATION.....	3-1
3.1. Description of Device (EUT).....	3-1
3.2. Tested Supporting System Details	3-2
3.3. Block diagram of connection between the EUT and simulators.....	3-3
3.4. Test Facility	3-4
3.5. Measurement Uncertainty (95% confidence levels, k=2).....	3-4
4. POWER LINE CONDUCTED EMISSION TEST	4-1
4.1. Test Equipment	4-1
4.2. Block Diagram of Test Setup.....	4-1
4.3. Power Line Conducted Emission Test Limits	4-1
4.4. Configuration of EUT on Test.....	4-2
4.5. Operating Condition of EUT	4-2
4.6. Test Procedure	4-2
4.7. Conducted Disturbance at Mains Terminals Test Results	4-3
5. RADIATED EMISSION TEST	5-1
5.1. Test Equipment	5-1
5.2. Block Diagram of Test Setup.....	5-1
5.3. Radiated Emission Limit	5-2
5.4. EUT Configuration on Test	5-2
5.5. Operating Condition of EUT	5-2
5.6. Test Procedure	5-3
5.7. Radiated Disturbance Test Results	5-3
6. PHOTOGRAPH	6-1
6.1. Photos of Power Line Conducted Emission Test.....	6-1
6.2. Photos of Radiated Emission Test (In Anechoic Chamber)	6-2
7. PHOTOS OF THE EUT	7-1

TEST REPORT CERTIFICATION

Applicant : TTE Technology Inc.
Manufacturer : TCL King Electrical Appliances (Huizhou) Co., Ltd.
EUT Description : LCD TV
FCC ID : W8UL40FHDF11TA
(A) MODEL NO. : L40FHDF11TA
(B) SERIAL NO. : N/A
(C) TEST VOLTAGE : AC 120V/60Hz

Measurement Standard Used:
FCC Rules and Regulations Part 15 Subpart B Class B 2008, ANSI C63.4-2003
ICES-003 Issue 4 February 2004.

The device described above is tested by AUDIX TECHNOLOGY (SHENZHEN) CO., LTD. to determine the maximum emission levels emanating from the device. The maximum emission levels are compared to the FCC Part 15 Subpart B Class B limits both conducted and radiated emissions. The test results are contained in this test report and AUDIX TECHNOLOGY (SHENZHEN) CO., LTD. is assumed of full responsibility for the accuracy and completeness of these tests.

After the test, our opinion is that EUT compliance with the requirement of the above standards.

This report applies to above tested sample only. This report shall not be reproduced in parts without written approval of AUDIX TECHNOLOGY (SHENZHEN) CO., LTD.

Date of Test : Sep.29,2010 Report of date: Oct.19,2010

Prepared by : Sarah Liu Reviewer by : Richzhy Zhong
Sarah Liu/ Assistant Richzhy Zhong / Assistant Manager



Approved & Authorized Signer : Ken Lu / Manager

1. DESCRIPTION OF VERSION

Edition No.	Date of Rev.	Summary	Report No.
0	May.31, 2010	Original Report	ACS-F10115
REV.1	Oct.19, 2010	1.add New Power : LS182CO 2. add New LCD Panel: SAMSUNG, LTA400HM05 3. Supplementary test data are recorded in this report.	ACS- F10115-1

Remark for Rev.1:

1. This report is an additional version with original report number ACS- F10115.
2. Through evaluation of the above difference, all the items were needed to be re-performed.
3. The EUT was retested and all the test data were recorded in this report.
4. This report is based on report of ACS- F10115

2. SUMMARY OF STANDARDS AND RESULTS

2.1. Description of Standards and Results

The EUT have been tested according to the applicable standards as referenced below.

EMISSION			
Description of Test Item	Standard	Limits	Results
Power Line Conducted Emission Test	FCC Part 15: 2008 ANSI C63.4: 2003	Class B	PASS
Radiated Emission Test	FCC Part 15: 2008 ANSI C63.4: 2003	Class B	PASS

3. GENERAL INFORMATION

3.1. Description of Device (EUT)

Description : LCD TV

Model Number : L40FHDF11TA

FCC ID : W8UL40FHDF11TA

Applicant : TTE Technology Inc.
5541 W. 74th St, Indianapolis, IN 46268, U.S.A.

Manufacturer : TCL King Electrical Appliances (Huizhou) Co., Ltd.
Section 19, Zhongkai Development Zone for New & High-Level
Tech Industries, Huizhou, Guangdong Province, China, 516006.

Frequencies used : and generated within device	X54M1	45-OSC54M-0Y1CR	54000000Hz
	LVDS CLOCK	80MHz	
	IF	45.75MHz	
	DC-DC	U302->385KHz	U303->1MHz
	DDR	440MHz	
	AMP IIS	384KHz	

Power Cord : Unshielded, Undetachable, 1.5m

Date of Test : Sep.29, 2010

Date of Receipt : Sep.29, 2010

Sample Type : Prototype production

3.2. Tested Supporting System Details

No.	Description	ACS No.	Manufacturer	Model	Serial Number	Approved type
1.	Personal Computer	Test PC O	DELL	Studio 540	H14XK2X	<input checked="" type="checkbox"/> FCC DoC <input checked="" type="checkbox"/> BSMI ID:R33002
		Power Cord: Unshielded, Detachable, 1.8m Display Card: HD3650 (DVI+Display+HDMI)				
2.	USB Keyboard	ACS-EMC- K04R	DELL	SK-8115	CN-ODJ313-71 616-6BB-049J	<input checked="" type="checkbox"/> FCC DoC <input checked="" type="checkbox"/> BSMI ID: T3A002
		Power Cord: shielded, Undetachable, 2.0m				
3.	USB Mouse	ACS-EMC-M05R	Lenovo	M028UOL	44N1421	<input checked="" type="checkbox"/> FCC DoC <input checked="" type="checkbox"/> BSMI ID: R41108
		Power Cord: shielded, Undetachable, 1.8m				
4.	Printer	ACS-EMC-PT04	HP	C9079A	N/A	<input checked="" type="checkbox"/> FCC DoC <input checked="" type="checkbox"/> BSMI ID: R33001
		USB Cable: Shielded, Detachable, 1.8m Power Cord: Unshielded, Detachable, 1.8m Power Adapter: HP, M/N: 0957-2119, BSMI ID: R33030, DC Cable: Unshielded, Detachable, 1.5m				
5.	HDD	ACS-EMC-HDD04	Terasys	F12-UF	A0100215-5390 002	<input checked="" type="checkbox"/> FCC DoC <input checked="" type="checkbox"/> BSMI ID: 4912A022
		USB Cable: Shielded, Detachable, 1.8m				
6.	Headphone	ACS-EMC-EP03	OVANN	OV880V	N/A	<input type="checkbox"/> FCC ID <input type="checkbox"/> BSMI ID
		Cable: Shielded, Undetachable, 4.0m				
7.	iPod	ACS-EMC-IP03	APPLE	A1199	YM711H3LVQ 5	<input checked="" type="checkbox"/> FCC DoC <input checked="" type="checkbox"/> BSMI ID: R33057
		Data Cable: Shielded, Detachable, 1.0m				
	Dummy Load (75Ω)	Y/Pb/Pr: Unshielded, Detachable, 1.5m				
8.	Dummy Load (10KΩ & 75Ω)	L+R+V: Unshielded, Detachable, 1.5m				

3.3. Block diagram of connection between the EUT and simulators

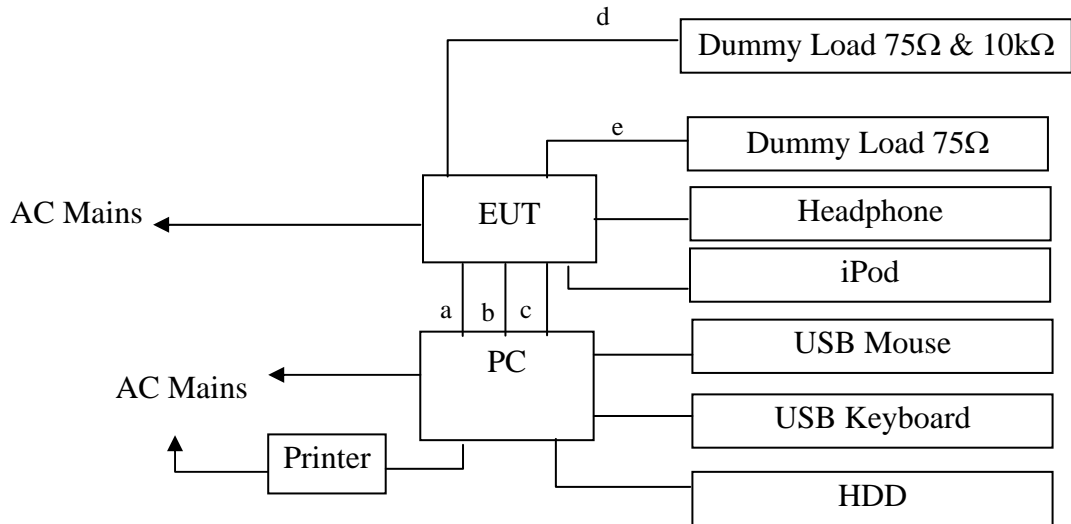

(EUT: LCD TV)

- a: VGA Cable
- b: HDMI Cable
- c: Audio Cable
- d: Y/Pb/Pr
- e: L+R+V

3.4. Test Facility

Site Description

Name of Firm : Audix Technology (Shenzhen) Co., Ltd.
 No. 6, Ke Feng Rd., 52 Block, Shenzhen
 Science & Industrial Park, Nantou,
 Shenzhen, Guangdong, China

3m Anechoic Chamber : Mar. 31, 2009 File on Federal
 Communication Commission
 Registration Number: 90454

3m & 10m Anechoic Chamber : Dec.30, 2009 File on Federal
 Communication Commission
 Registration Number: 794232

EMC Lab. : Accredited by DATech, German
 Registration Number: DAT-P-091/99-01
 Feb,02, 2009

Accredited by NVLAP, USA
 NVLAP Code: 200372-0
 Apr. 01, 2010

3.5. Measurement Uncertainty (95% confidence levels, k=2)

Test Item	Uncertainty
Uncertainty for Conduction emission test in No. 2 Conduction	3.48 dB
Uncertainty for Radiation Emission test in 3m chamber	4.20 dB (Polarize: V)
	4.66 dB (Polarize: H)
Uncertainty for test site temperature and humidity	0.3°C
	2%

4. POWER LINE CONDUCTED EMISSION TEST

4.1. Test Equipment

Item	Equipment	Manufacturer	Model No.	Serial No.	Last Cal.	Cal. Interval
1.	Test Receiver	Rohde & Schwarz	ESHS10	838693/001	Dec.18, 09	1 Year
2.	L.I.S.N.#1	Rohde & Schwarz	ESH2-Z5	834066/011	Mar.30, 10	1 Year
3.	L.I.S.N.#3	Kyoritsu	KNW-242C	8-1920-1	May.08, 10	1 Year
4.	Terminator	Hubersuhner	50Ω	No. 1	May.08, 10	1 Year
5.	RF Cable	Fujikura	3D-2W	LISN Cable 1#	May.08, 10	1Year
6.	Coaxial Switch	Anritsu	MP59B	M55367	May.08, 10	1 Year
7.	Passive Probe	Rohde & Schwarz	ESH2-Z3	299.7810.52	May.08, 10	1 Year
8.	Pulse Limiter	Rohde & Schwarz	ESH3-Z2	100341	May.08, 10	1 Year

4.2. Block Diagram of Test Setup

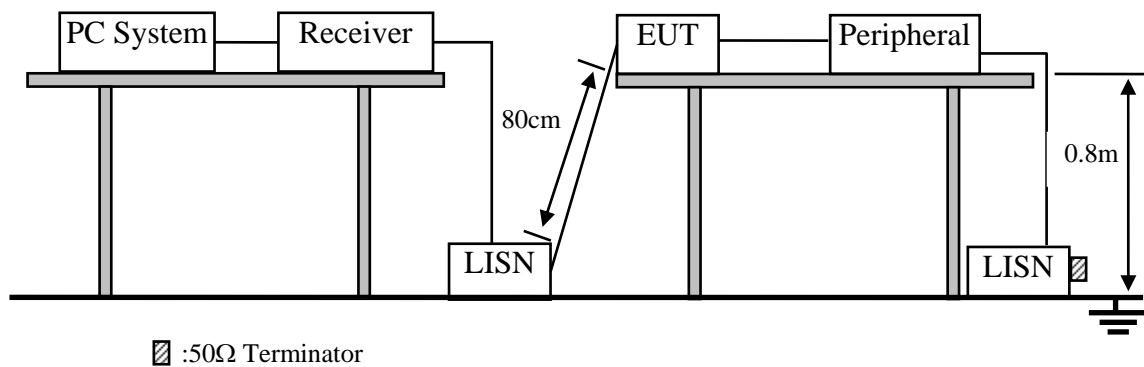

4.3. Power Line Conducted Emission Test Limits

Frequency	Maximum RF Line Voltage	
	Quasi-Peak Level dB(μV)	Average Level dB(μV)
150kHz ~ 500kHz	66 ~ 56*	56 ~ 46*
500kHz ~ 5MHz	56	46
5MHz ~ 30MHz	60	50

Notes: 1. * Decreasing linearly with logarithm of frequency.

2. The lower limit shall apply at the transition frequencies.

4.4. Configuration of EUT on Test

The following equipment are installed on Power Line Conducted Emission Test to meet the commission requirement and operating regulations in a manner which tends to maximize its emission characteristics in a normal application.

4.4.1. LCD TV (EUT)

Model Number : L40FHDF11TA

Serial Number : N/A

4.4.2. Support Equipment : As Tested Supporting System Detail, in Section 3.2.

4.5. Operating Condition of EUT

4.5.1. Setup the EUT and simulator as shown as Section 4.2.

4.5.2. Turn on the power of all equipment.

4.5.3. PC system ran the Self-test program “EMC Test. exe” by windows XP and sent “H” Character to LCD TV (EUT) , the Screen of EUT displayed and filled with “H” pattern, use white letters on a black background, set the contrast control to maximum, set the brightness control to maximum and measure it.

4.5.4. The PC system was running the program “1kHz signal Playing” and sending sound to EUT.

4.5.5. The other peripheral devices were driven and operated in turn during all testing.

4.6. Test Procedure

The EUT was placed on a non-metallic table, 80cm above the ground plane. The EUT Power connected to the power mains through a line impedance stabilization network (L.I.S.N. 1#). This provided a 50-ohm coupling impedance for the EUT (Please refer to the block diagram of the test setup and photographs). The other peripheral devices power cord connected to the power mains through a line impedance stabilization network (L.I.S.N.#3). Both sides of power line were checked for maximum conducted interference. In order to find the maximum emission, the relative positions of equipments and all of the interface cables were changed according to ANSI C63.4-2003 on conducted Emission test.

The bandwidth of test receiver (R&S TEST RECEIVER ESHS10) is set at 10kHz.

The frequency range from 150kHz to 30MHz is checked. The test result are reported on Section 4.7.

4.7. Conducted Disturbance at Mains Terminals Test Results

PASS. (All emissions not reported below are too low against the prescribed limits.)

The EUT with the following test modes were tested and selected to read Q.P values and Average values, all the test results are listed in next pages.

EUT: LCD TV Model No. : L40FHDF11TA

Test Date: Sep.29, 2010 Temperature: 23°C Humidity: 54%

The details of test modes are as follows :

NO.	Resolution & Frequency	Reference Test Data No.	
		LINE	NEUTRAL
1.	VGA 640*480/60Hz	#2	#1
2.	VGA 800*600/60Hz	#3	#4
3.	VGA 1024*768/60Hz	#6	#5
4.	HDMI1 1080P	#7	#8
5.	HDMI2 1080P	#10	#9
6.	HDMI3 1080P	#11	#12

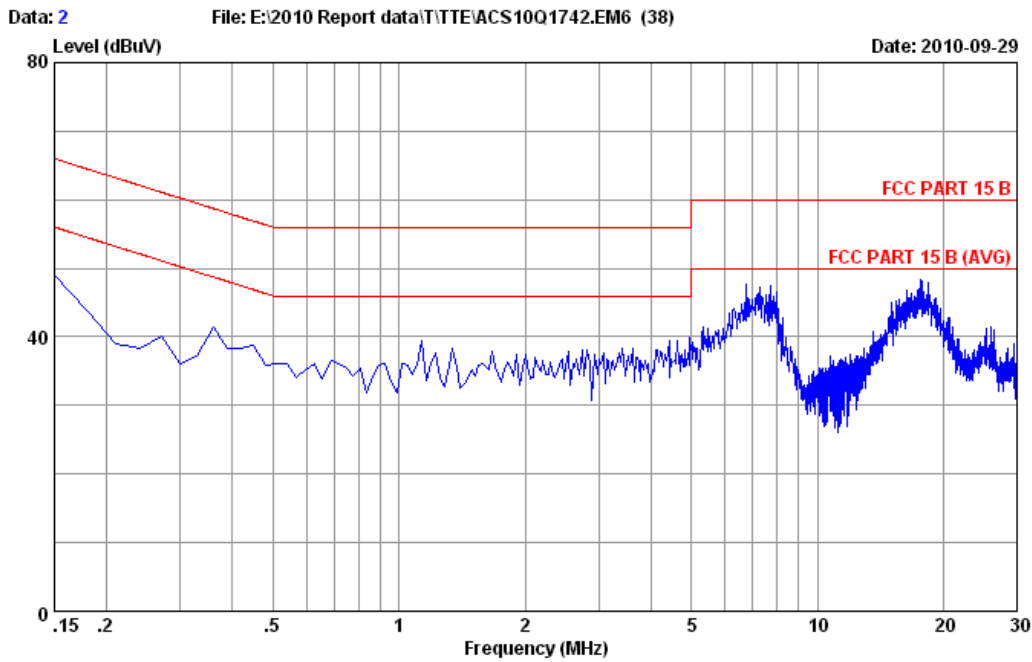

Site no :Audix No.2 Conduction Data No :2
 Dis./Ant. **: 2010 ENV4200 LISN phase:LINE
 Limit :FCC PART 15 B
 Env./Ins. :29.5°C/55% Engineer :Restar
 EUT :LCD TV M/N:L40FHDF11TA
 Power Rating :AC 120V/60Hz
 Test Mode :Running "H" Pattern And 1KHz Playing
 VGA:640*480@60Hz

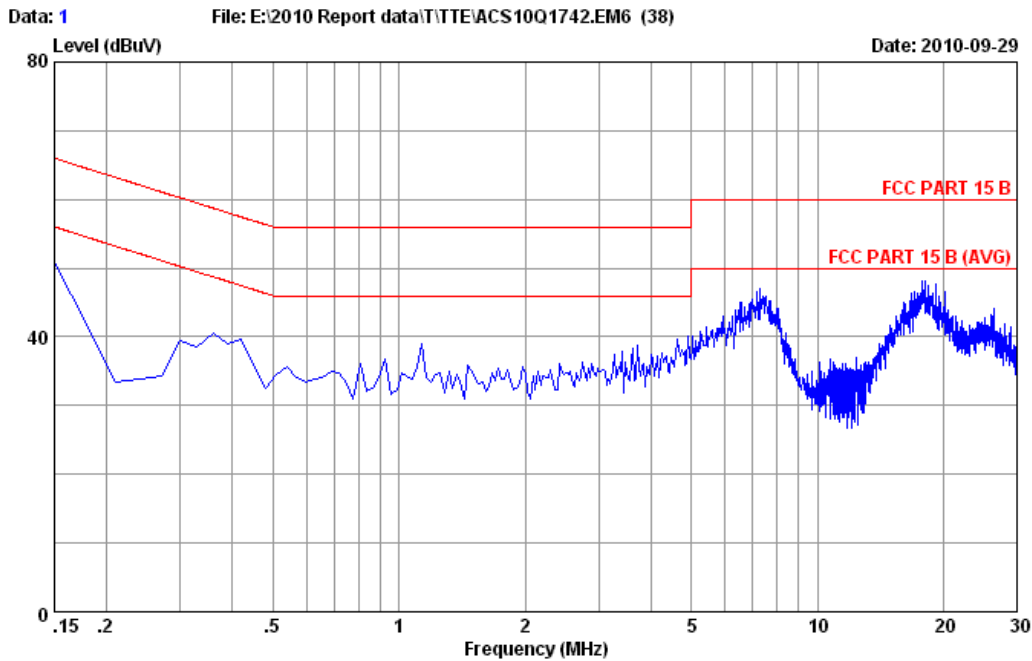

Site no :Audix No.2 Conduction Data No :1
 Dis./Ant. **: 2010 ENV4200 LISN phase:NEUTRAL
 Limit :FCC PART 15 B
 Env./Ins. :29.5°C/55% Engineer :Restar
 EUT :LCD TV M/N:L40FHDF11TA
 Power Rating :AC 120V/60Hz
 Test Mode :Running "H" Pattern And 1KHz Playing
 VGA:640*480@60Hz

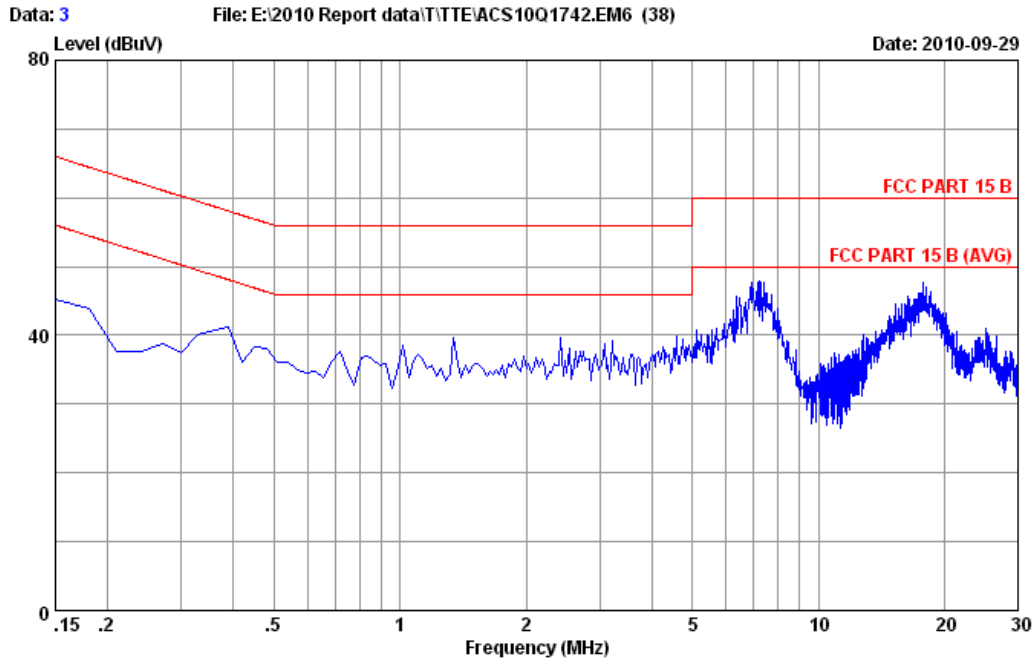

Site no :Audix No.2 Conduction Data No :3
 Dis./Ant. **: 2010 ENV4200 LISN phase:LINE
 Limit :FCC PART 15 B
 Env./Ins. :29.5°C/55% Engineer :Restar
 EUT :LCD TV M/N:L40FHDF11TA
 Power Rating :AC 120V/60Hz
 Test Mode :Running "H" Pattern And 1KHz Playing
 VGA:800*600@60Hz

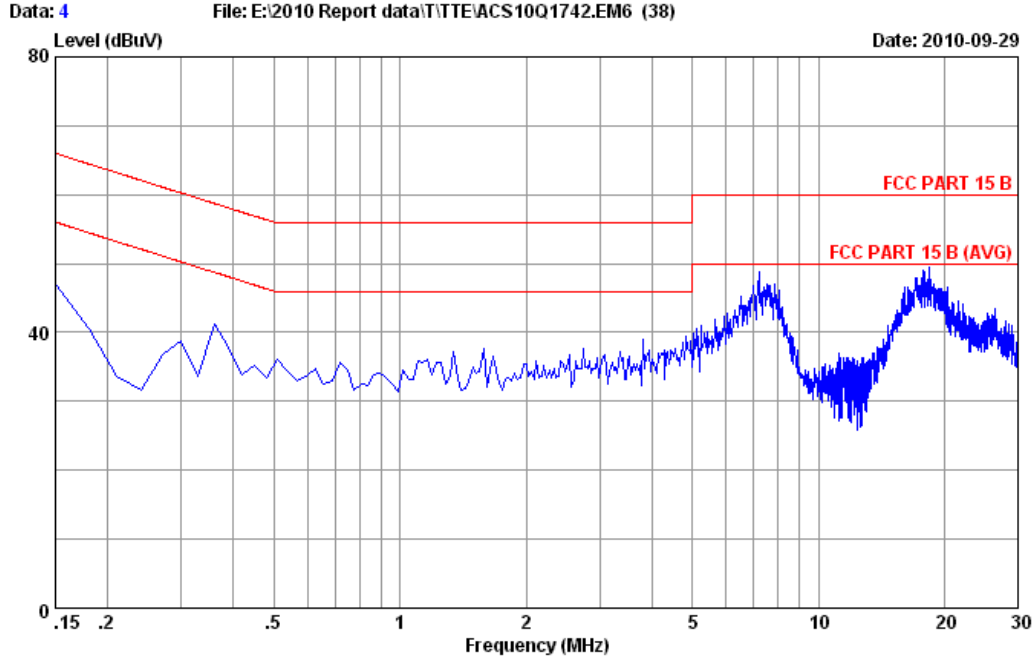

Site no :Audix No.2 Conduction Data No :4
 Dis./Ant. **: 2010 ENV4200 LISN phase:NEUTRAL
 Limit :FCC PART 15 B
 Env./Ins. :29.5°C/55% Engineer :Restar
 EUT :LCD TV M/N:L40FHDF11TA
 Power Rating :AC 120V/60Hz
 Test Mode :Running "H" Pattern And 1KHz Playing
 VGA:800*600@60Hz

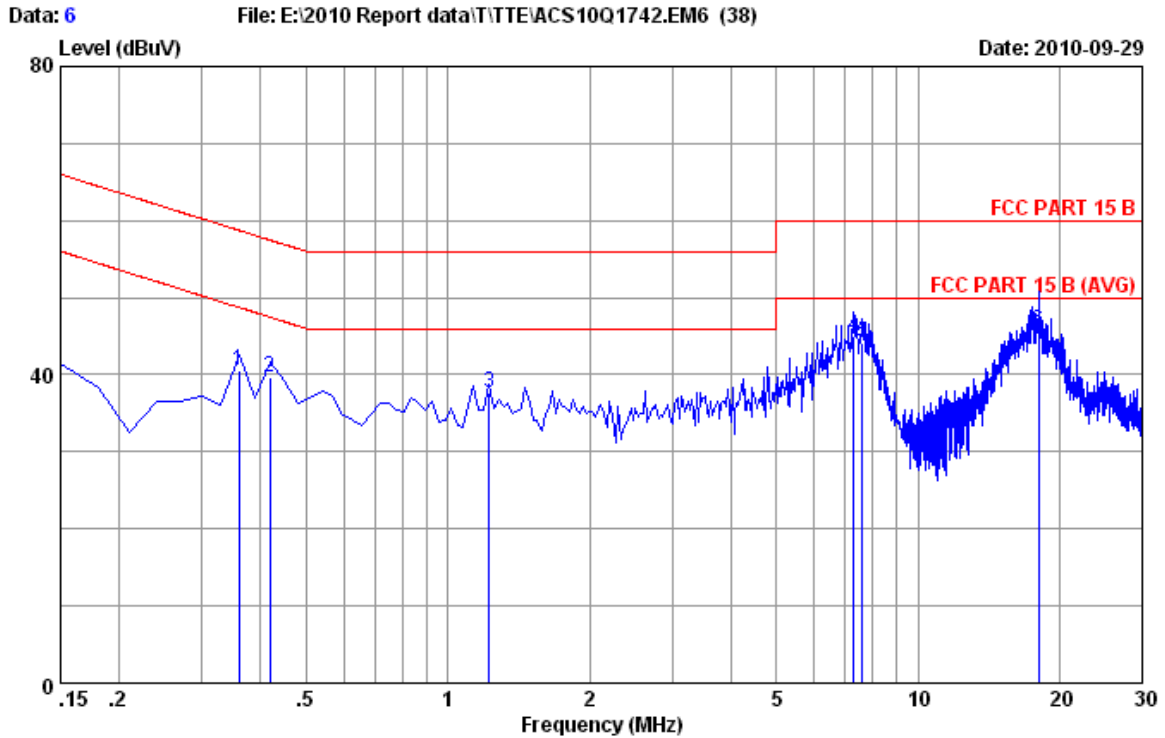

Site no :Audix No.2 Conduction Data No :6
 Dis./Ant. **: 2010 ENV4200 LISN phase:LINE
 Limit :FCC PART 15 B
 Env./Ins. :29.5°C/55% Engineer :Restar
 EUT :LCD TV M/N:L40FHDF11TA
 Power Rating :AC 120V/60Hz
 Test Mode :Running "H" Pattern And 1KHz Playing
 VGA:1024*768@60Hz

No	Freq (MHz)	LISN Factor (dB)	Cable Loss (dB)	Reading (dBUV)	Emission Level (dBUV)	Limits (dBUV)	Margin (dB)	Remark
1	0.35895	10.17	9.88	20.46	40.51	58.75	18.24	QP
2	0.41865	10.17	9.88	19.55	39.60	57.47	17.87	QP
3	1.225	10.19	9.90	17.68	37.77	56.00	18.23	QP
4	7.314	10.31	10.10	24.67	45.08	60.00	14.92	QP
5	7.613	10.32	10.11	23.75	44.18	60.00	15.82	QP
6	18.090	10.38	10.57	24.80	45.75	60.00	14.25	QP

Remarks: 1.Emission Level=LISN Factor+Cable Loss(Include 10dB pulse limit)+Reading.
 2.If the average limit is met when using a quasi-peak detector, the EUT shall be deemed to meet both limits and measurement with average detector is unnecessary.

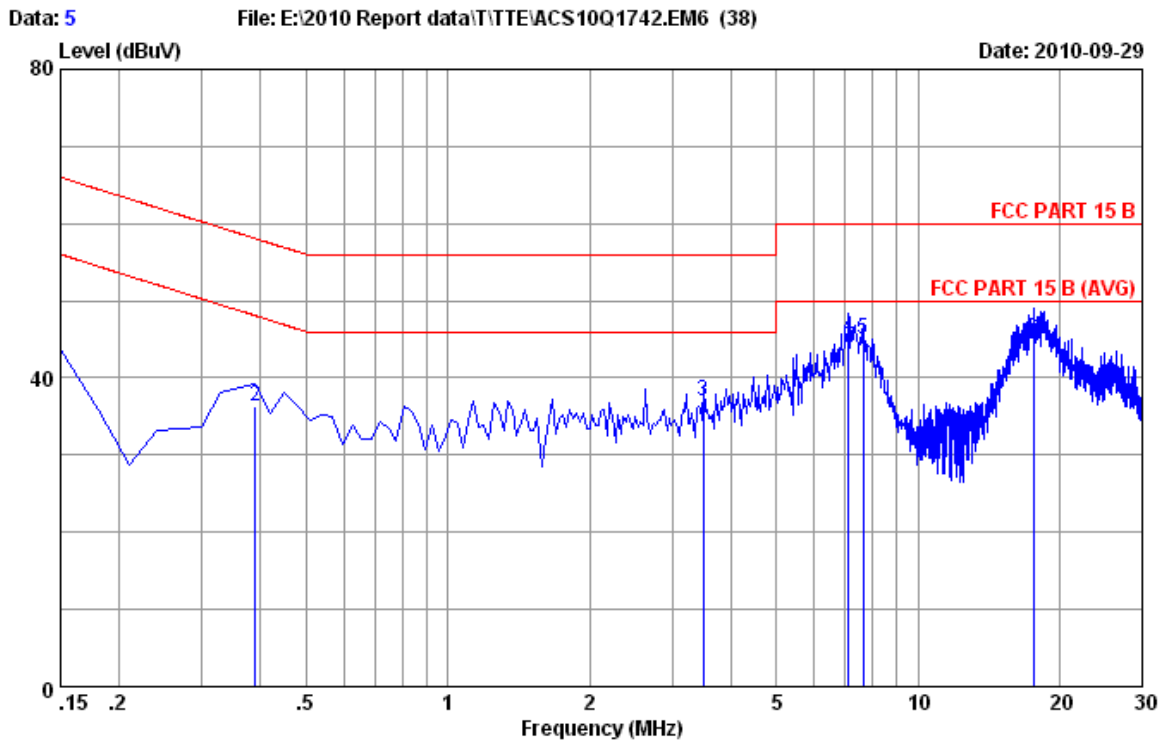

Site no :Audix No.2 Conduction Data No :5
 Dis./Ant. **: 2010 ENV4200 LISN phase:NEUTRAL
 Limit :FCC PART 15 B
 Env./Ins. :29.5°C/55% Engineer :Restar
 EUT :LCD TV M/N:L40FHDF11TA
 Power Rating :AC 120V/60Hz
 Test Mode :Running "H" Pattern And 1KHz Playing
 VGA:1024*768@60Hz

No	Freq (MHz)	LISN Factor (dB)	Cable Loss (dB)	Reading (dBUV)	Emission Level (dBUV)	Limits (dBUV)	Margin (dB)	Remark
1	0.15000	10.22	9.87	21.55	41.64	66.00	24.36	QP
2	0.38880	10.19	9.88	16.19	36.26	58.09	21.83	QP
3	3.493	10.28	9.97	16.64	36.89	56.00	19.11	QP
4	7.105	10.31	10.09	24.86	45.26	60.00	14.74	QP
5	7.642	10.32	10.11	24.65	45.08	60.00	14.92	QP
6	17.612	10.54	10.55	23.87	44.96	60.00	15.04	QP

Remarks: 1.Emission Level=LISN Factor+Cable Loss(Include 10dB pulse limit)+Reading.
 2.If the average limit is met when using a quasi-peak detector, the EUT shall be deemed to meet both limits and measurement with average detector is unnecessary.

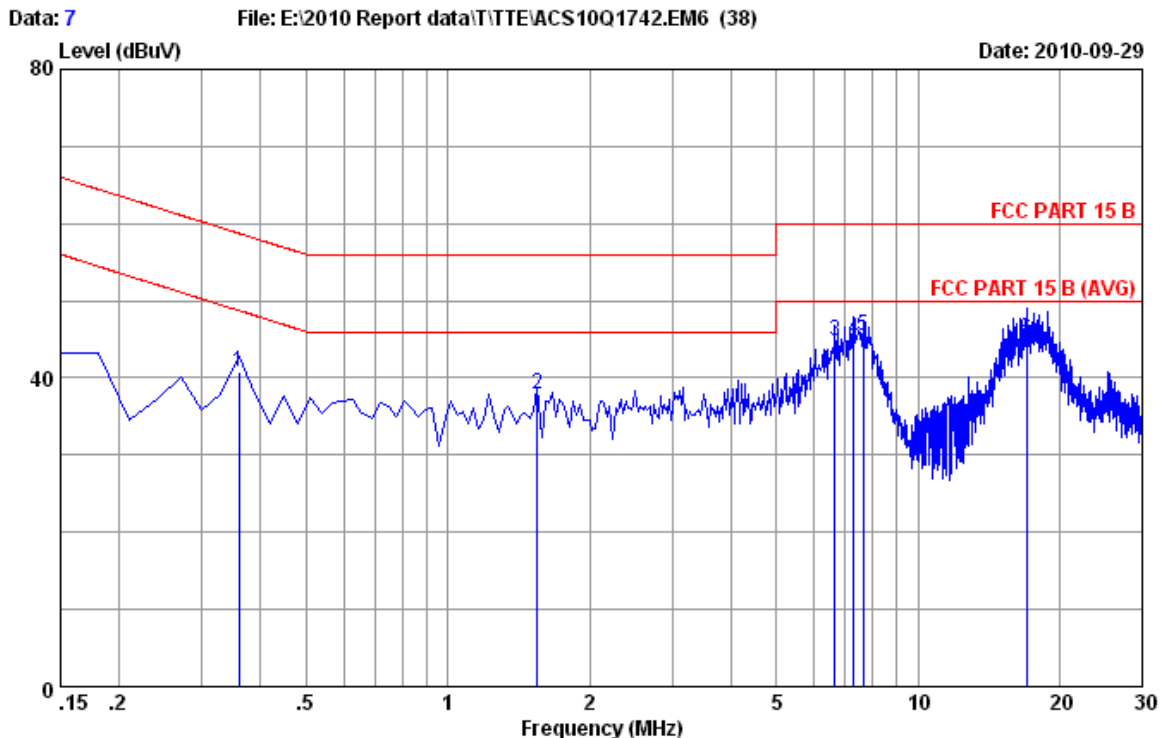

Site no :Audix No.2 Conduction Data No :7
 Dis./Ant. **: 2010 ENV4200 LISN phase:LINE
 Limit :FCC PART 15 B
 Env./Ins. :29.5*C/55% Engineer :Restar
 EUT :LCD TV M/N:L40FHDF11TA
 Power Rating :AC 120V/60Hz
 Test Mode :Running "H" Pattern And 1KHz Playing
 HDMI 1:1080P

No	Freq (MHz)	LISN Factor (dB)	Cable Loss (dB)	Reading (dBUV)	Emission Level (dBUV)	Limits (dBUV)	Margin (dB)	Remark
1	0.35895	10.17	9.88	20.63	40.68	58.75	18.07	QP
2	1.553	10.20	9.92	17.66	37.78	56.00	18.22	QP
3	6.657	10.29	10.07	24.49	44.85	60.00	15.15	QP
4	7.314	10.31	10.10	24.55	44.96	60.00	15.04	QP
5	7.642	10.32	10.11	24.96	45.39	60.00	14.61	QP
6	17.015	10.39	10.52	24.19	45.10	60.00	14.90	QP

Remarks: 1.Emission Level=LISN Factor+Cable Loss(Include 10dB pulse limit)+Reading.
 2.If the average limit is met when using a quasi-peak detector.
 the EUT shall be deemed to meet both limits and measurement
 with average detector is unnecessary.

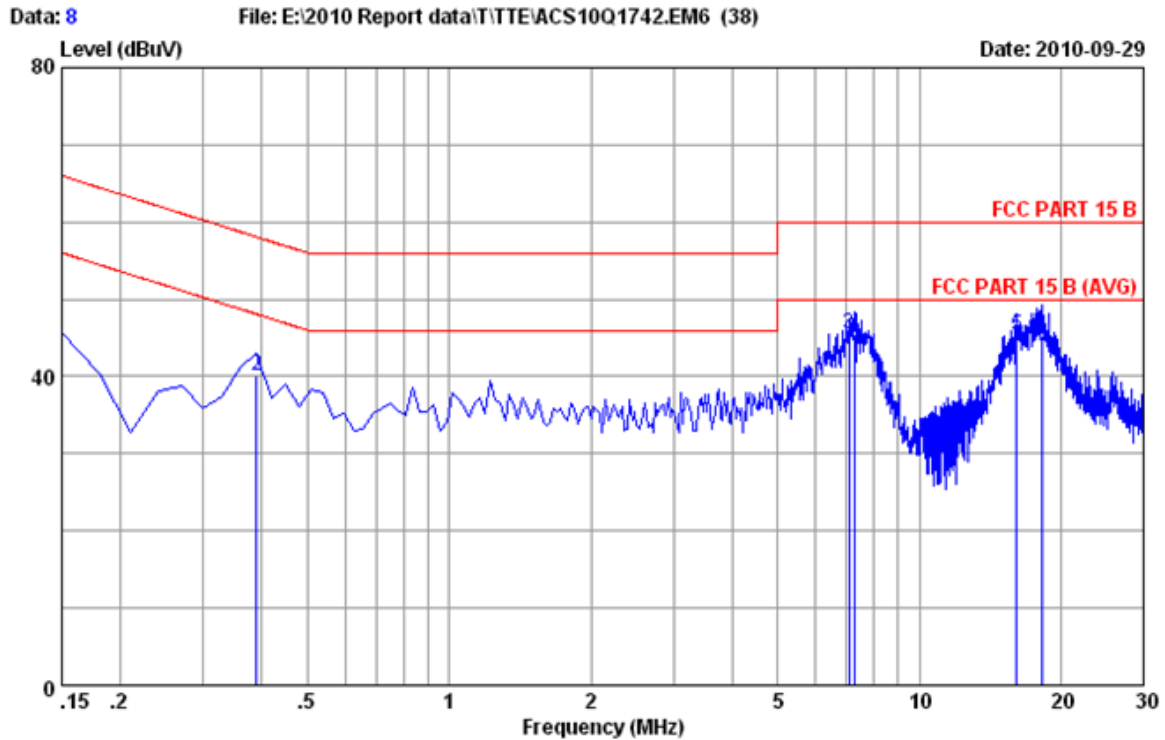

Site no :Audix No.2 Conduction Data No :8
 Dis./Ant. **: 2010 ENV4200 LISN phase:NEUTRAL
 Limit :FCC PART 15 B
 Env./Ins. :29.5°C/55% Engineer :Restar
 EUT :LCD TV M/N:L40FHDF11TA
 Power Rating :AC 120V/60Hz
 Test Mode :Running "H" Pattern And 1KHz Playing
 HDMI 1:1080P

No	Freq (MHz)	LISN Factor (dB)	Cable Loss (dB)	Reading (dBuV)	Emission Level (dBuV)	Limits (dBuV)	Margin (dB)	Remark
1	0.15000	10.22	9.87	22.59	42.68	66.00	23.32	QP
2	0.38880	10.19	9.88	20.02	40.09	58.09	18.00	QP
3	7.075	10.31	10.09	25.09	45.49	60.00	14.51	QP
4	7.314	10.31	10.10	24.96	45.37	60.00	14.63	QP
5	16.090	10.56	10.48	24.11	45.15	60.00	14.85	QP
6	18.179	10.53	10.57	24.17	45.27	60.00	14.73	QP

Remarks: 1.Emission Level=LISN Factor+Cable Loss(Include 10dB pulse limit)+Reading.
 2.If the average limit is met when using a quasi-peak detector.
 the EUT shall be deemed to meet both limits and measurement
 with average detector is unnecessary.

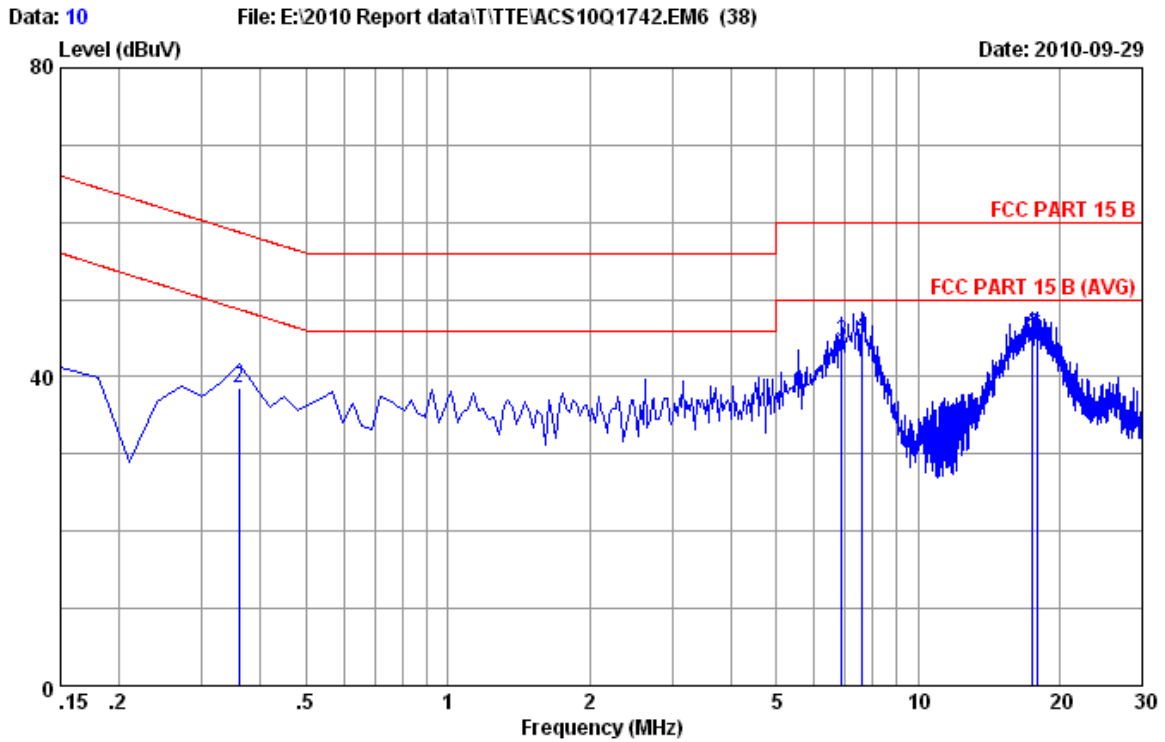

Site no :Audix No.2 Conduction Data No :10
 Dis./Ant. **: 2010 ENV4200 LISN phase:LINE
 Limit :FCC PART 15 B
 Env./Ins. :29.5°C/55% Engineer :Restar
 EUT :LCD TV M/N:L40FHDF11TA
 Power Rating :AC 120V/60Hz
 Test Mode :Running "H" Pattern And 1KHz Playing
 HDMI 2:1080P

No	Freq (MHz)	LISN Factor (dB)	Cable Loss (dB)	Reading (dBUV)	Emission Level (dBUV)	Limits (dBUV)	Margin (dB)	Remark
1	0.15000	10.11	9.87	20.32	40.30	66.00	25.70	QP
2	0.35895	10.17	9.88	18.57	38.62	58.75	20.13	QP
3	6.896	10.30	10.08	24.23	44.61	60.00	15.39	QP
4	7.613	10.32	10.11	24.95	45.38	60.00	14.62	QP
5	17.553	10.38	10.55	24.48	45.41	60.00	14.59	QP
6	17.911	10.38	10.56	24.43	45.37	60.00	14.63	QP

Remarks: 1.Emission Level=LISN Factor+Cable Loss(Include 10dB pulse limit)+Reading.
 2.If the average limit is met when using a quasi-peak detector, the EUT shall be deemed to meet both limits and measurement with average detector is unnecessary.

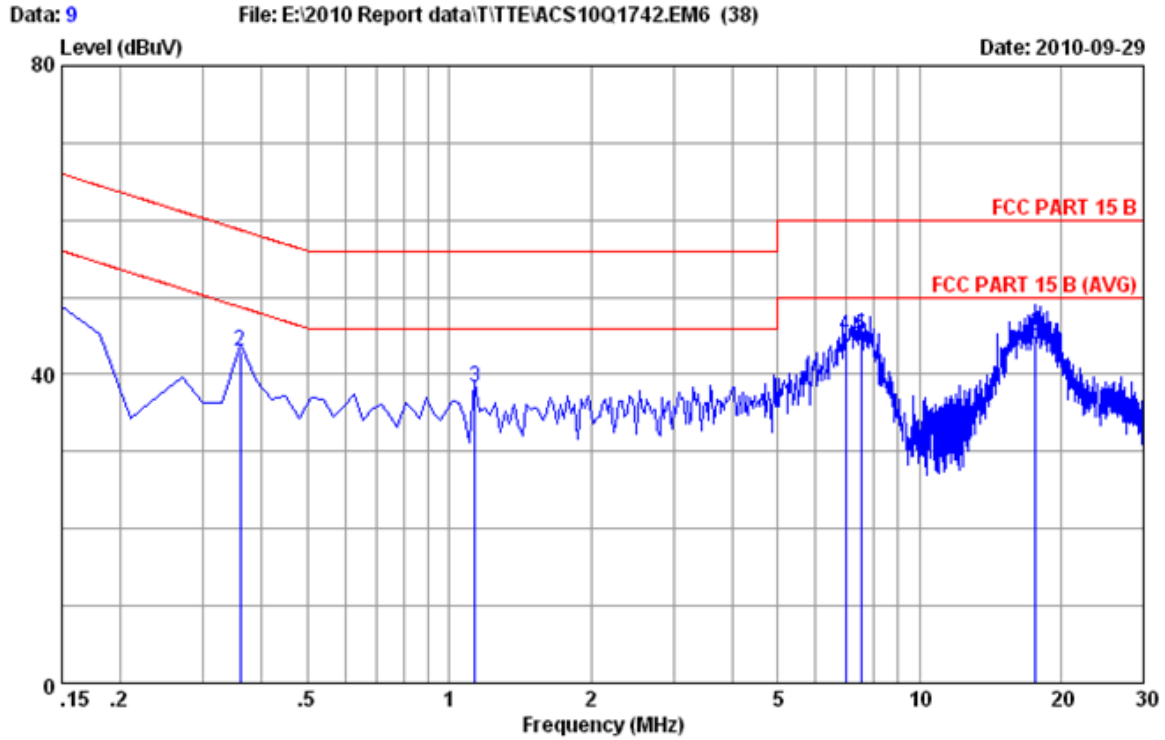

Site no :Audix No.2 Conduction Data No :9
 Dis./Ant. **: 2010 ENV4200 LISN phase:NEUTRAL
 Limit :FCC PART 15 B
 Env./Ins. :29.5°C/55% Engineer :Restar
 EUT :LCD TV M/N:L40FHDF11TA
 Power Rating :AC 120V/60Hz
 Test Mode :Running "H" Pattern And 1KHz Playing
 HDMI 2:1080P

No	Freq (MHz)	LISN Factor (dB)	Cable Loss (dB)	Reading (dBuV)	Emission Level (dBuV)	Limits (dBuV)	Margin (dB)	Remark
1	0.15000	10.22	9.87	26.62	46.71	66.00	19.29	QP
2	0.35895	10.19	9.88	22.88	42.95	58.75	15.80	QP
3	1.135	10.24	9.90	18.08	38.22	56.00	17.78	QP
4	6.986	10.31	10.09	24.59	44.99	60.00	15.01	QP
5	7.523	10.32	10.11	24.55	44.98	60.00	15.02	QP
6	17.582	10.54	10.55	23.99	45.08	60.00	14.92	QP

Remarks: 1.Emission Level=LISN Factor+Cable Loss(Include 10dB pulse limit)+Reading.
 2.If the average limit is met when using a quasi-peak detector.
 the EUT shall be deemed to meet both limits and measurement
 with average detector is unnecessary.

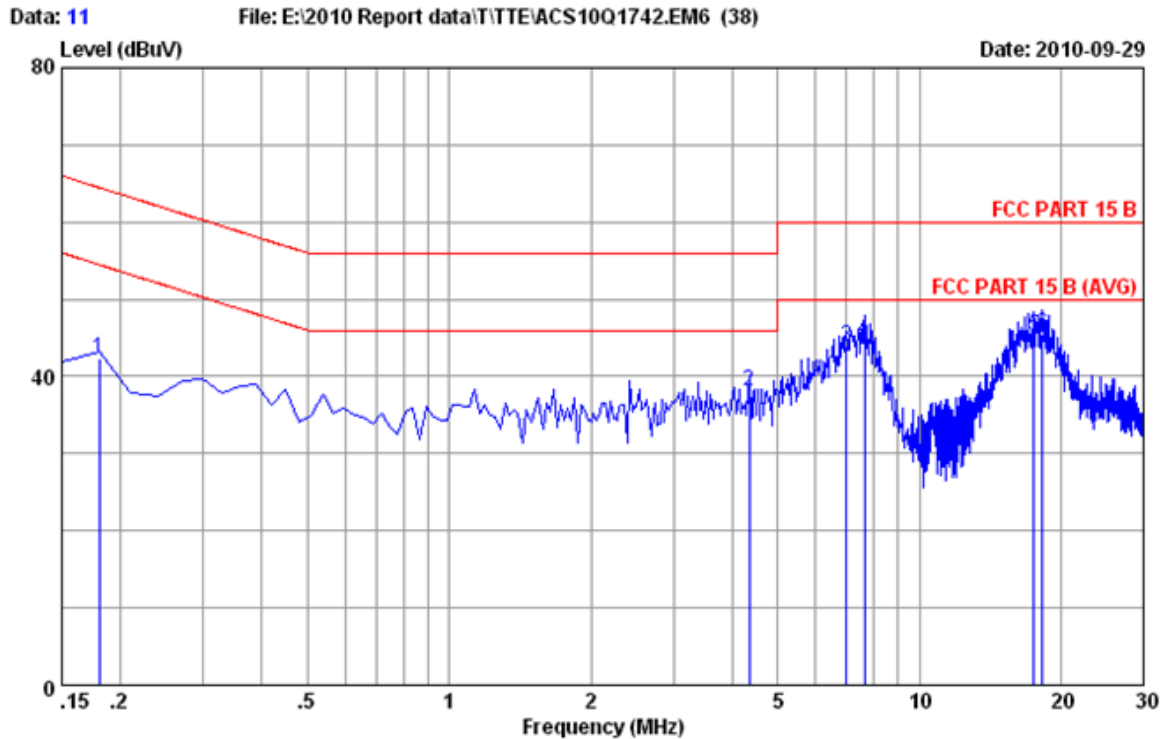

Site no :Audix No.2 Conduction Data No :11
 Dis./Ant. **: 2010 ENV4200 LISN phase:LINE
 Limit :FCC PART 15 B
 Env./Ins. :29.5°C/55% Engineer :Restar
 EUT :LCD TV M/N:L40FHDF11TA
 Power Rating :AC 120V/60Hz
 Test Mode :Running "H" Pattern And 1KHz Playing
 HDMI 3:1080P

No	Freq (MHz)	LISN Factor (dB)	Cable Loss (dB)	Reading (dBuV)	Emission Level (dBuV)	Limits (dBuV)	Margin (dB)	Remark
1	0.17985	10.13	9.87	22.24	42.24	64.49	22.25	QP
2	4.359	10.23	9.98	17.95	38.16	56.00	17.84	QP
3	7.016	10.30	10.09	23.56	43.95	60.00	16.05	QP
4	7.642	10.32	10.11	24.45	44.88	60.00	15.12	QP
5	17.523	10.38	10.55	24.33	45.26	60.00	14.74	QP
6	18.299	10.37	10.58	24.52	45.47	60.00	14.53	QP

Remarks: 1.Emission Level=LISN Factor+Cable Loss(Include 10dB pulse limit)+Reading.
 2.If the average limit is met when using a quasi-peak detector.
 the EUT shall be deemed to meet both limits and measurement
 with average detector is unnecessary.

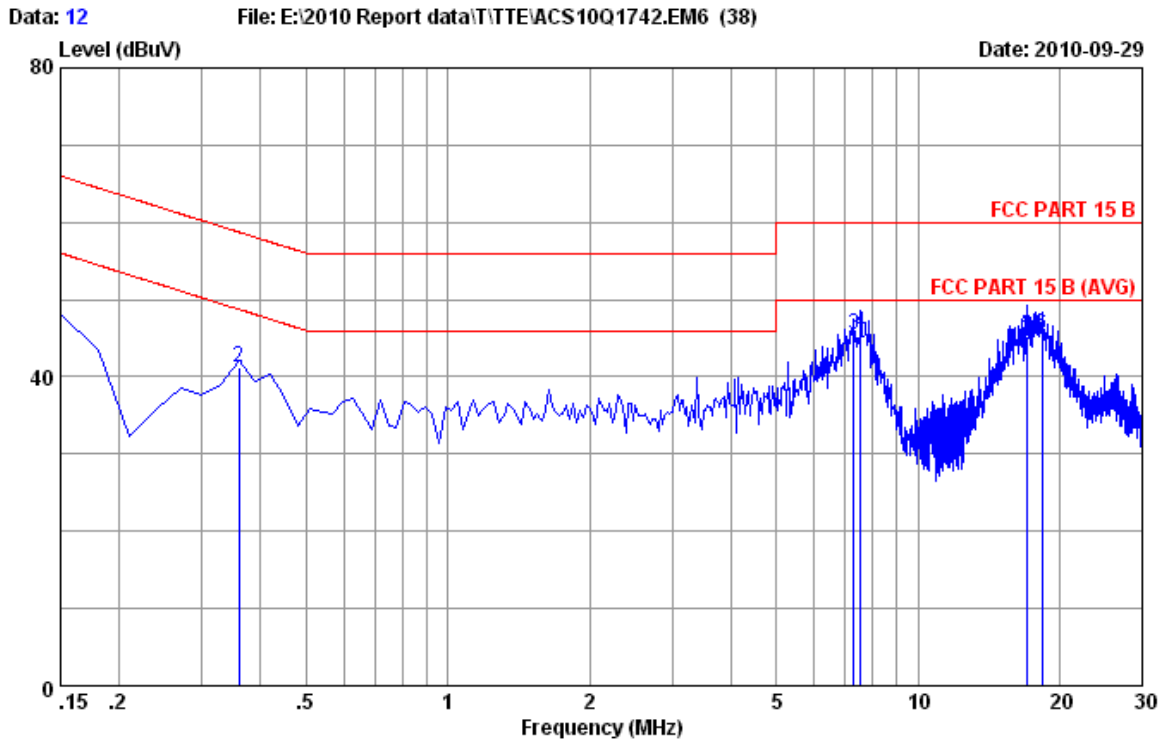

Site no :Audix No.2 Conduction Data No :12
 Dis./Ant. **: 2010 ENV4200 LISN phase:NEUTRAL
 Limit :FCC PART 15 B
 Env./Ins. :29.5°C/55% Engineer :Restar
 EUT :LCD TV M/N:L40FHDF11TA
 Power Rating :AC 120V/60Hz
 Test Mode :Running "H" Pattern And 1KHz Playing
 HDMI 3:1080P

No	Freq (MHz)	LISN Factor (dB)	Cable Loss (dB)	Reading (dBUV)	Emission Level (dBUV)	Limits (dBUV)	Margin (dB)	Remark
1	0.15000	10.22	9.87	26.10	46.19	66.00	19.81	QP
2	0.35895	10.19	9.88	21.15	41.22	58.75	17.53	QP
3	7.314	10.31	10.10	24.98	45.39	60.00	14.61	QP
4	7.553	10.32	10.11	25.17	45.60	60.00	14.40	QP
5	17.015	10.54	10.52	24.15	45.21	60.00	14.79	QP
6	18.388	10.53	10.59	24.26	45.38	60.00	14.62	QP

Remarks: 1.Emission Level=LISN Factor+Cable Loss(Include 10dB pulse limit)+Reading.
 2.If the average limit is met when using a quasi-peak detector, the EUT shall be deemed to meet both limits and measurement with average detector is unnecessary.

5. RADIATED EMISSION TEST

5.1. Test Equipment

5.1.1. For frequency range 30MHz~1000MHz

Item	Equipment	Manufacturer	Model No.	Serial No.	Last Cal.	Cal. Interval
1	3#Chamber	AUDIX	N/A	N/A	Dec.05,09	1 Year
2	EMI Spectrum	Agilent	E4407B	MY41440292	May.08, 10	1 Year
3	Test Receiver	Rohde & Schwarz	ESVS10	834468/011	May.08, 10	1 Year
4	Amplifier	HP	8447D	2648A04738	May.08, 10	1 Year
5	Bilog Antenna	Schaffner	CBL6111C	2598	Dec.14, 09	1 Year
6	RF Cable	MIYAZAKI	8D-FB	3# Chamber No.1	May.08, 10	1 Year
7	Coaxial Switch	Anritsu	MP59B	M73989	May.08, 10	1 Year

5.1.2. For frequency range 1GHz~6GHz

Item	Equipment	Manufacturer	Model No.	Serial No.	Last Cal.	Cal. Interval
1	Spectrum Analyzer	Agilent	E7405A	MY45116588	May.08, 10	1 Year
2	Horn Antenna	EMCO	3115	9607-4877	Nov.25, 09	1.5 Year
3	Amplifier	Agilent	8449B	3008A00863	May.08, 10	1 Year
4	RF Cable	Hubersuhner	SUCOFLEX102	28620/2	May.08, 10	1 Year
5	RF Cable	Hubersuhner	SUCOFLEX102	29091/2	May.08, 10	1 Year

5.2. Block Diagram of Test Setup

For frequency range 30MHz-1000MHz

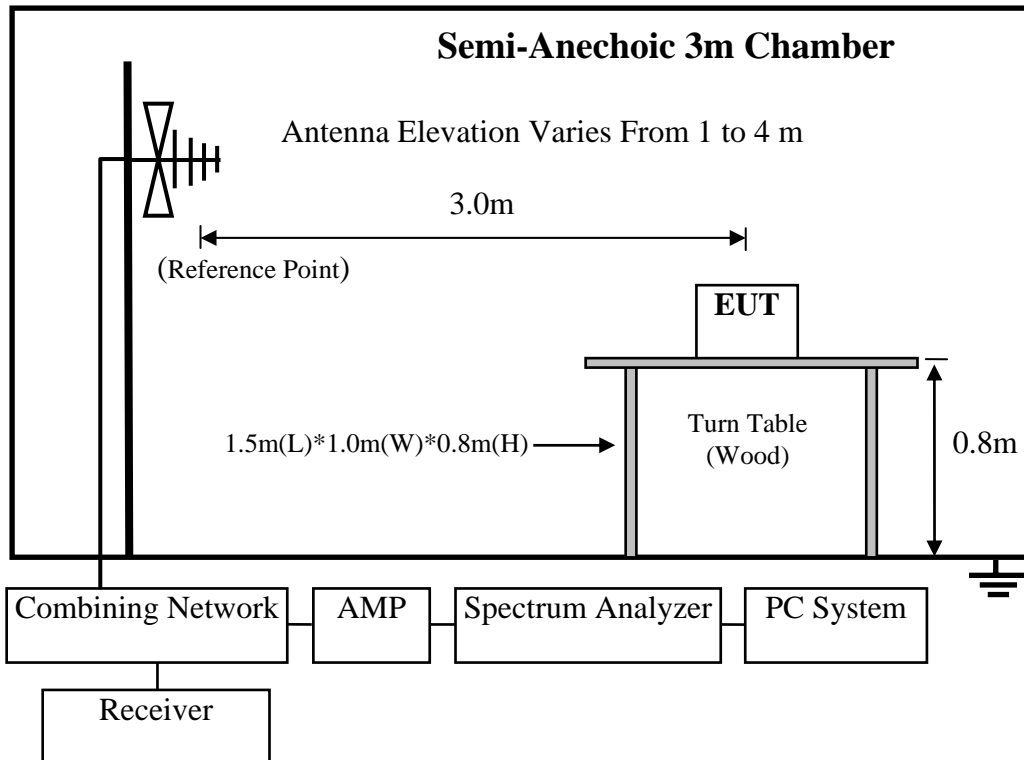

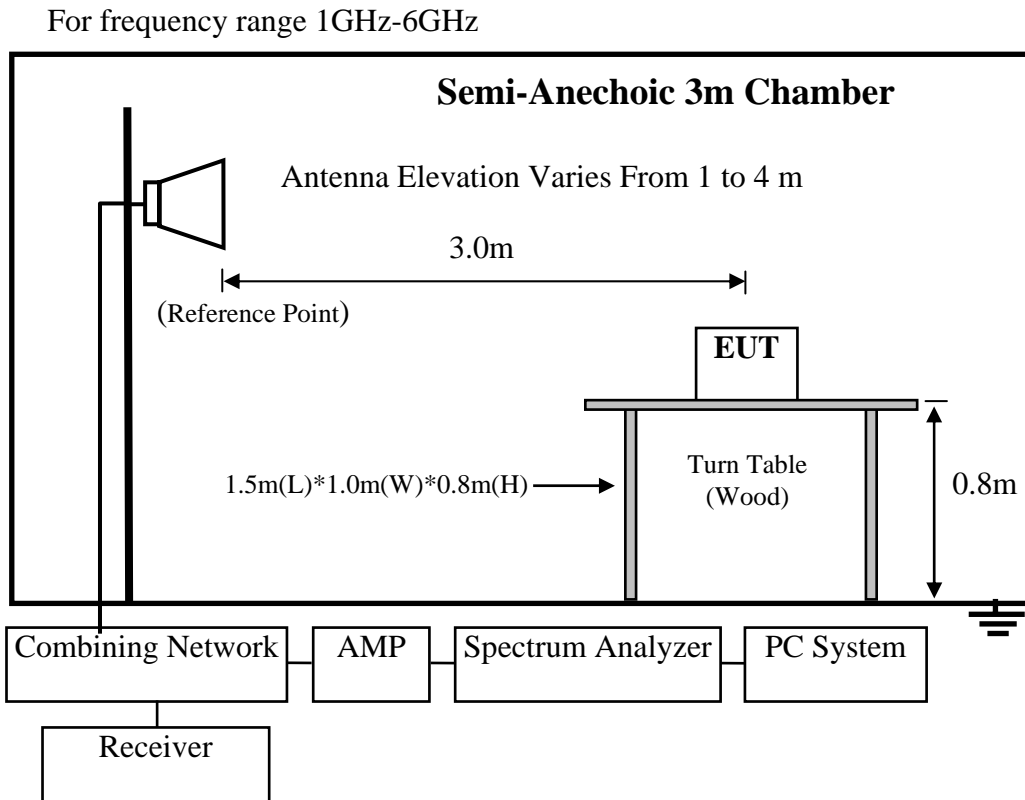

5.3. Radiated Emission Limit

Frequency MHz	Distance (Meters)	Field Strengths Limits dB(μV)/m
30 ~ 88	3	40.0
88 ~ 216	3	43.5
216 ~ 960	3	46.0
960 ~ 1000	3	54.0
Above 1000	3	74(Peak)54(Average)

- Remark: (1) Emission level = Antenna Factor + Cable Loss + Reading
Emission level = Antenna Factor - Amp Factor + Cable Loss + Reading (above 1000MHz)
- (2) The smaller limit shall apply at the cross point between two frequency bands.
- (3) Distance is the distance in meters between the measuring instrument, antenna and the closest point of any part of the device or system.

5.4. EUT Configuration on Test

The configurations of EUT are listed in Section 4.4

5.5. Operating Condition of EUT

Same as Conducted Emission test that is listed in Section 4.5. except the test set up replaced by Section 5.2.

5.6. Test Procedure

The EUT was placed on a non-metallic table, 80 cm above the ground plane inside a semi-anechoic chamber. An antenna was located 3m from the EUT on an adjustable mast. A pre-scan was first performed in order to find prominent radiated emissions. For final emissions measurements at each frequency of interest, the EUT were rotated and the antenna height was varied between 1m and 4m in order to maximize the emission. Measurements in both horizontal and vertical polarities were made and the data was recorded. In order to find the maximum emission, the relative positions of equipments and all of the interface cables were changed according to ANSI C63.4-2003 on Radiated Emission test.

The bandwidth of the EMI test receiver (R&S ESVS10) is set at 120kHz for frequency range from 30MHz to 1000 MHz.

The bandwidth of the Spectrum's RBW is set at 1MHz and VBW is set at 3MHz for peak emissions measurement above 1GHz and 1MHz RBW, 10Hz VBW for average emissions measure above 1GHz.

The frequency range from 30MHz to 6000MHz is checked. The test result are reported on Section 5.7.

5.7. Radiated Disturbance Test Results

PASS. (All emissions not reported below are too low against the prescribed limits.)

The EUT with the following test modes were tested and selected to read Q.P values, all the test results are listed in next pages.

EUT: LCD TV Model No. : L40FHDF11TA

Test Date: Sep.29, 2010 Temperature: 24°C Humidity: 56%

The details of test modes are as follows :

NO.	Resolution & Frequency	Reference Test Data No.	
		Horizontal	Vertical
1.	VGA 640*480 60Hz	#22	#21
2.	VGA 800*600 60Hz	#20	#19
3. ※	VGA 1024*768 60Hz	#18	#17
4.	HDMI1 1080P	#24	#23
5.	HDMI2 1080P	#26	#25
6.	HDMI3 1080P	#27	#28

(※ Worst test mode)

For frequency range 1GHz~6GHz

The EUT with below test modes ere measured within Anechoic Chamber and the test results listed in next pages

Test Date: Sep.29, 2010 Temperature: 24°C Humidity: 56%

NO.	Resolution & Frequency	Reference Test Data No.	
		Horizontal	Vertical
1.	VGA 1024*768 60Hz	#1, #2	#3, #4
2.	HDMI1 1080P	#5, #6	#7, #8
3.	HDMI2 1080P	#9, #10	#11, #12
4.	HDMI3 1080P	#13, #14	#15, #16

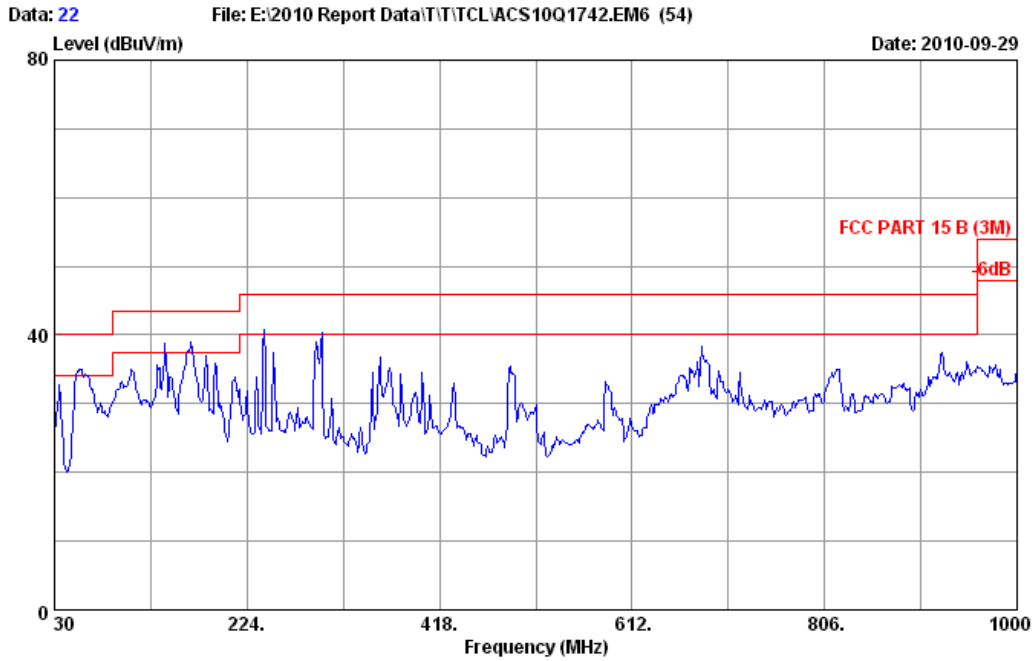

Site no. : 3m Chamber Data no. : 22
 Dis. / Ant. : 3m 2010 CBL6111C Ant. pol. : HORIZONTAL
 Limit : FCC PART 15 B (3M)
 Env. / Ins. : 24°C/56% Engineer : Victory
 EUT : LCD TV M/N:L40FHDF11TA
 Power rating : AC 120V/60Hz
 Test Mode : Running "H" Pattern And 1KHz Playing
 : VGA:640*480@60Hz

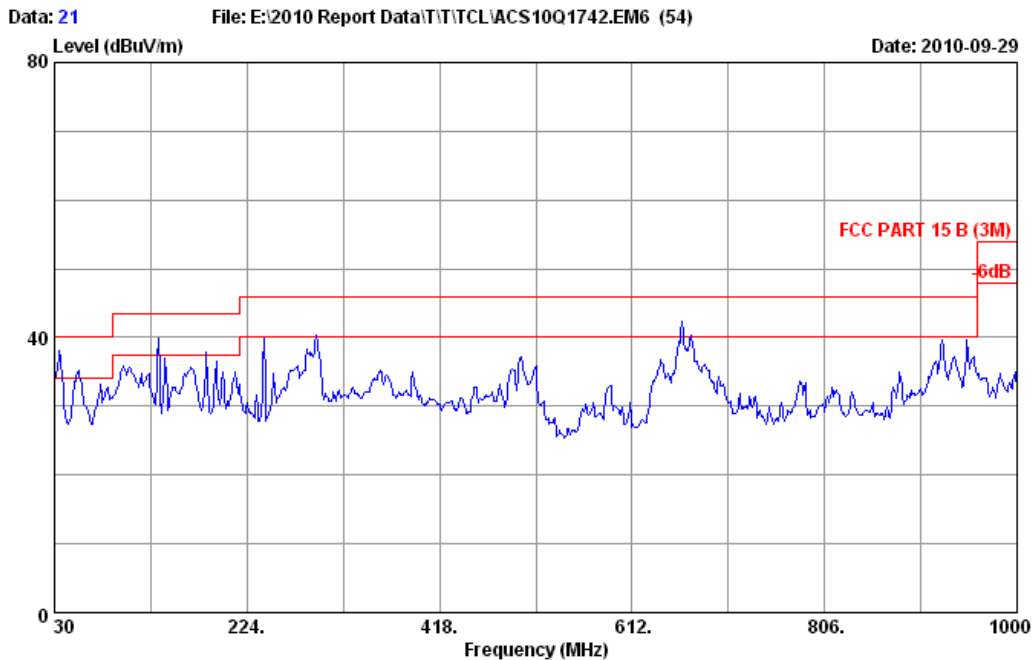

Site no. : 3m Chamber Data no. : 21
 Dis. / Ant. : 3m 2010 CBL6111C Ant. pol. : VERTICAL
 Limit : FCC PART 15 B (3M)
 Env. / Ins. : 24°C/56% Engineer : Victory
 EUT : LCD TV M/N:L40FHDF11TA
 Power rating : AC 120V/60Hz
 Test Mode : Running "H" Pattern And 1KHz Playing
 : VGA:640*480@60Hz

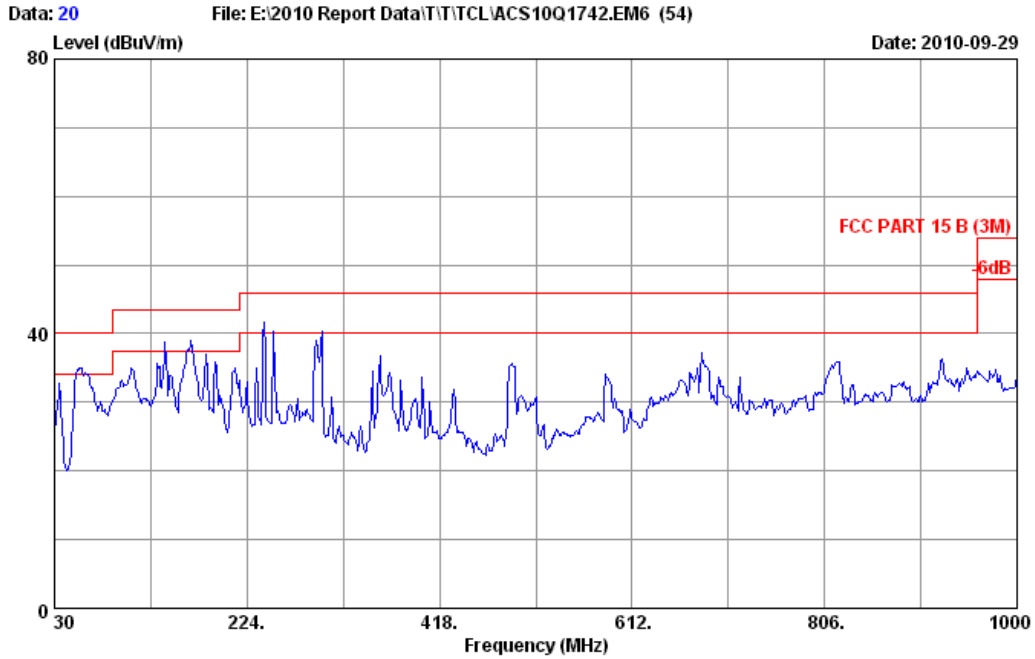

Site no. : 3m Chamber Data no. : 20
 Dis. / Ant. : 3m 2010 CBL6111C Ant. pol. : HORIZONTAL
 Limit : FCC PART 15 B (3M)
 Env. / Ins. : 24°C/56% Engineer : Victory
 EUT : LCD TV M/N:L40FHDF11TA
 Power rating : AC 120V/60Hz
 Test Mode : Running "H" Pattern And 1KHz Playing
 : VGA:800*600@60Hz

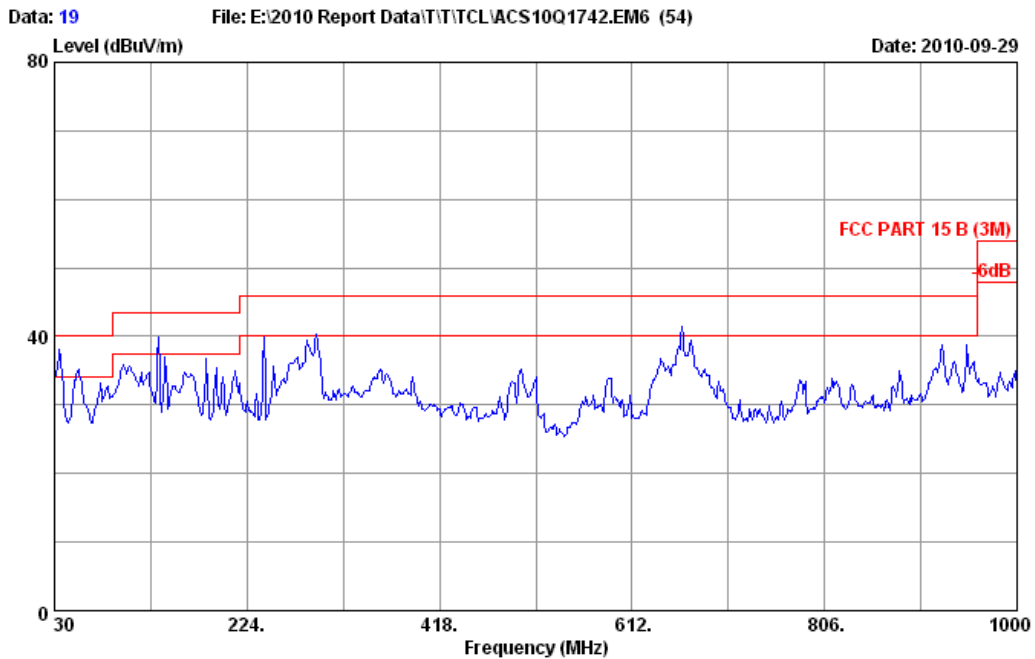

Site no. : 3m Chamber Data no. : 19
 Dis. / Ant. : 3m 2010 CBL6111C Ant. pol. : VERTICAL
 Limit : FCC PART 15 B (3M)
 Env. / Ins. : 24°C/56% Engineer : Victory
 EUT : LCD TV M/N:L40FHDF11TA
 Power rating : AC 120V/60Hz
 Test Mode : Running "H" Pattern And 1KHz Playing
 : VGA:800*600@60Hz

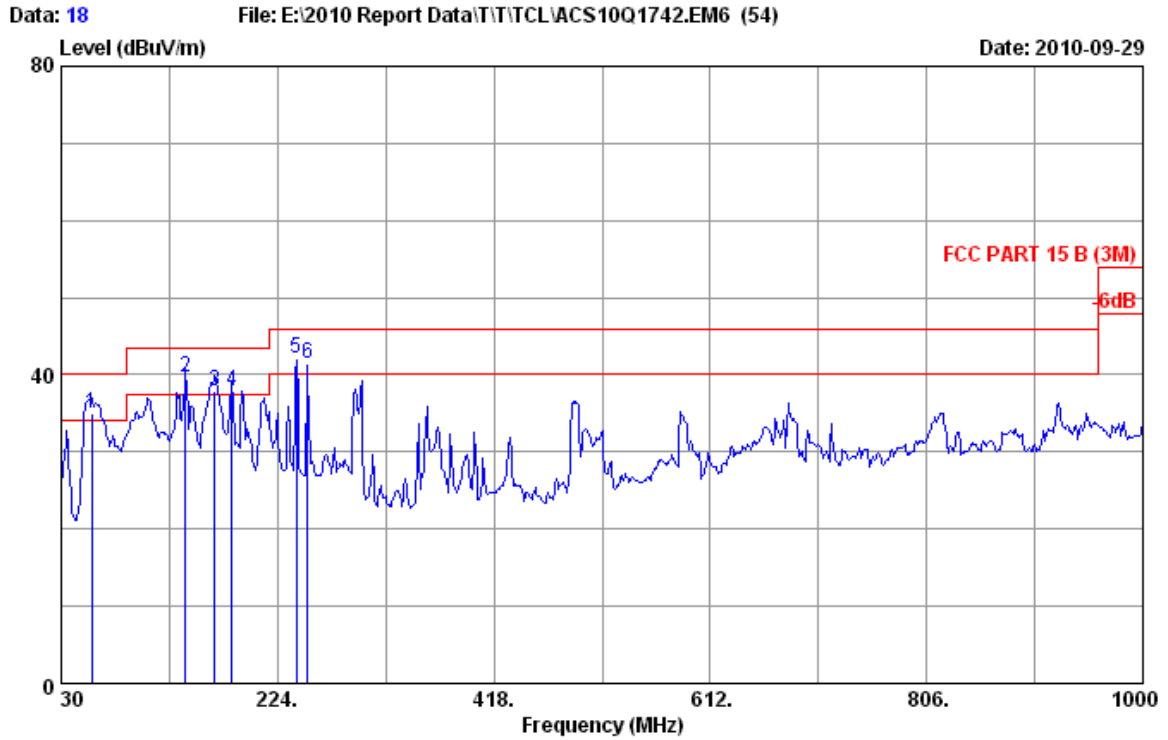

Site no. : 3m Chamber Data no. : 18
 Dis. / Ant. : 3m 2010 CBL6111C Ant. pol. : HORIZONTAL
 Limit : FCC PART 15 B (3M)
 Env. / Ins. : 24°C/56% Engineer : Victory
 EUT : LCD TV M/N:L40FHDF11TA
 Power rating : AC 120V/60Hz
 Test Mode : Running "H" Pattern And 1KHz Playing
 : VGA:1024*768@60Hz

No.	Freq. (MHz)	Ant. Factor (dB/m)	Cable Loss (dB)	Reading (dBUV)	Emission Level (dBUV/m)	Limits (dBUV/m)	Margin (dB)	Remark
1	57.160	6.66	0.83	27.54	35.03	40.00	4.97	QP
2	141.550	11.97	1.14	26.61	39.72	43.50	3.78	QP
3	167.740	10.40	1.34	26.18	37.92	43.50	5.58	QP
4	183.260	9.34	1.53	27.07	37.94	43.50	5.56	QP
5	240.930	11.87	2.08	28.20	42.15	46.00	3.85	QP
6	251.160	12.90	2.18	26.33	41.41	46.00	4.59	QP

Remarks: 1. Emission Level= Antenna Factor + Cable Loss + Reading.
 2. The emission levels that are 20dB below the official limit are not reported.

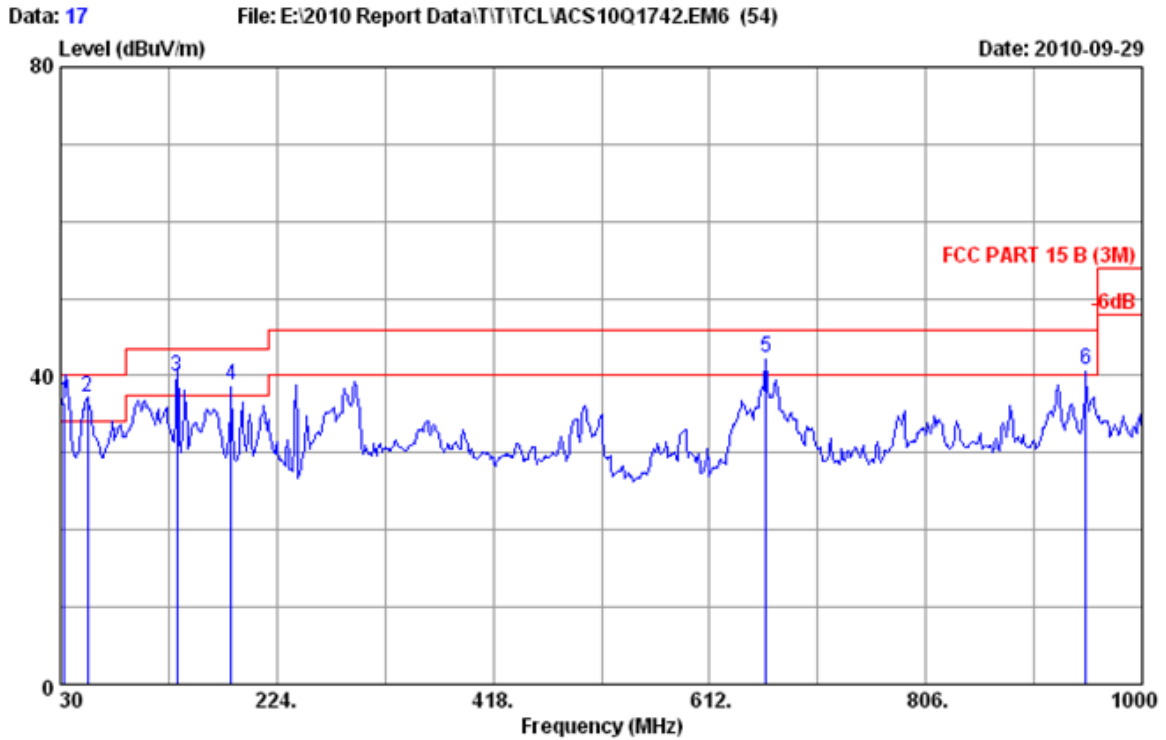

Site no. : 3m Chamber
 Dis. / Ant. : 3m 2010 CBL6111C
 Limit : FCC PART 15 B (3M)
 Env. / Ins. : 24°C/56%
 EUT : LCD TV M/N:L40FHDF11TA
 Power rating : AC 120V/60Hz
 Test Mode : Running "H" Pattern And 1KHz Playing
 : VGA:1024*768@60Hz
 Data no. : 17
 Ant. pol. : VERTICAL
 Engineer : Victory

No.	Freq. (MHz)	Ant. Factor (dB/m)	Cable Loss (dB)	Reading (dBuV)	Emission Level (dBuV/m)	Limits (dBuV/m)	Margin (dB)	Remark
1	33.220	18.32	0.63	17.50	36.45	40.00	3.55	QP
2	54.250	7.54	0.81	28.85	37.20	40.00	2.80	QP
3	134.760	12.10	1.13	26.73	39.96	43.50	3.54	QP
4	183.260	9.34	1.53	27.96	38.83	43.50	4.67	QP
5	662.440	20.65	4.36	17.39	42.40	46.00	3.60	QP
6	949.560	24.10	5.39	11.22	40.71	46.00	5.29	QP

Remarks: 1. Emission Level= Antenna Factor + Cable Loss + Reading.
 2. The emission levels that are 20dB below the official limit are not reported.

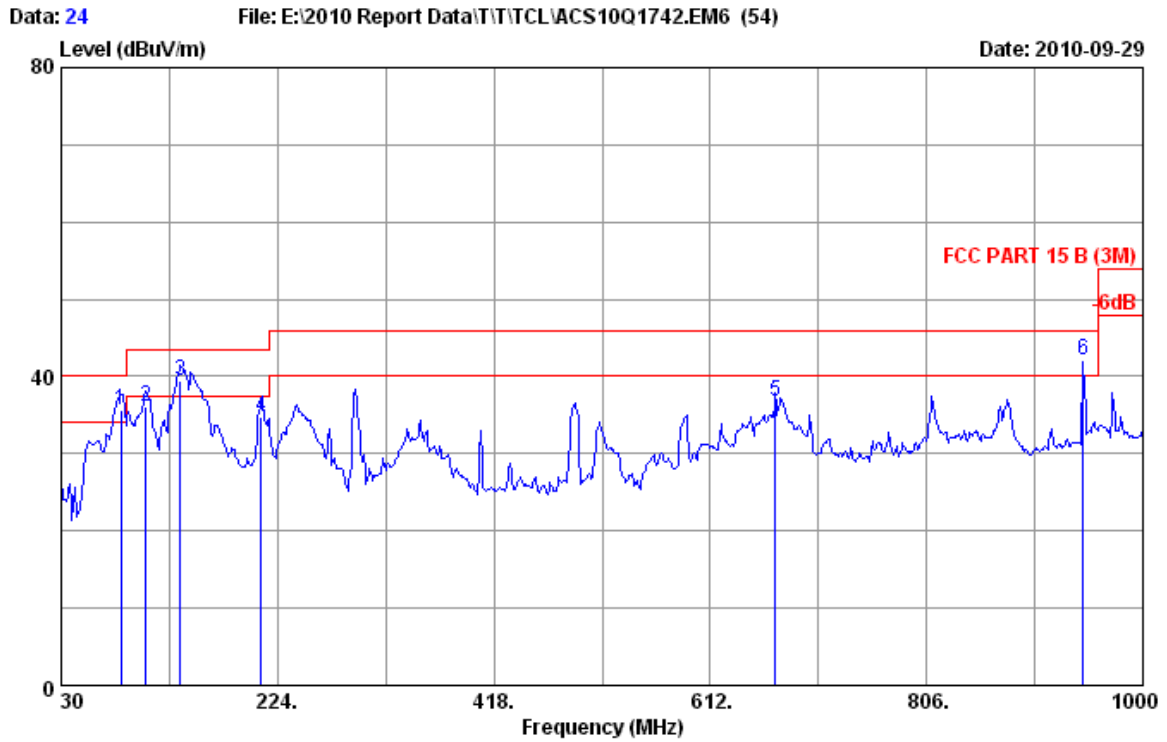

Site no. : 3m Chamber Data no. : 24
 Dis. / Ant. : 3m 2010 CBL6111C Ant. pol. : HORIZONTAL
 Limit : FCC PART 15 B (3M)
 Env. / Ins. : 24°C/56% Engineer : Victory
 EUT : LCD TV M/N:L40FHDF11TA
 Power rating : AC 120V/60Hz
 Test Mode : Running "H" Pattern And 1KHz Playing
 : HDMI1:1080P

No.	Freq. (MHz)	Ant. Factor (dB/m)	Cable Loss (dB)	Reading (dBUV)	Emission Level (dBUV/m)	Limits (dBUV/m)	Margin (dB)	Remark
1	83.350	8.16	1.01	26.54	35.71	40.00	4.29	QP
2	105.660	11.00	1.12	23.88	36.00	43.50	7.50	QP
3	136.700	12.06	1.13	26.27	39.46	43.50	4.04	QP
4	209.450	10.10	1.81	22.80	34.71	43.50	8.79	QP
5	670.200	20.80	4.39	11.63	36.82	46.00	9.18	QP
6	946.650	24.01	5.38	12.80	42.19	46.00	3.81	QP

Remarks: 1. Emission Level= Antenna Factor + Cable Loss + Reading.
 2. The emission levels that are 20dB below the official limit are not reported.

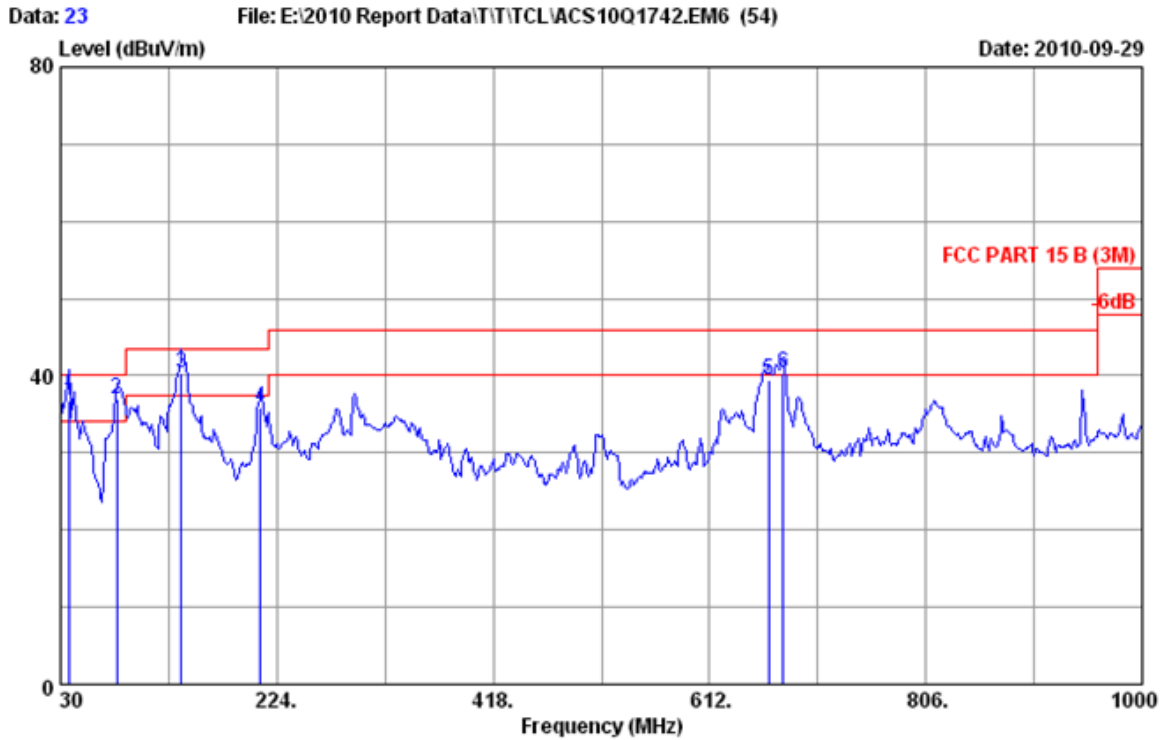

Site no. : 3m Chamber Data no. : 23
 Dis. / Ant. : 3m 2010 CBL6111C Ant. pol. : VERTICAL
 Limit : FCC PART 15 B (3M)
 Env. / Ins. : 24°C/56% Engineer : Victory
 EUT : LCD TV M/N:L40FHDF11TA
 Power rating : AC 120V/60Hz
 Test Mode : Running "H" Pattern And 1KHz Playing
 : HDMI1:1080P

No.	Freq. (MHz)	Ant. Factor (dB/m)	Cable Loss (dB)	Reading (dBuV)	Emission Level (dBuV/m)	Limits (dBuV/m)	Margin (dB)	Remark
1	37.760	15.58	0.67	20.50	36.75	40.00	3.25	QP
2	80.440	7.80	0.99	28.13	36.92	40.00	3.08	QP
3	138.640	12.02	1.14	27.19	40.35	43.50	3.15	QP
4	209.450	10.10	1.81	23.94	35.85	43.50	7.65	QP
5	665.350	20.71	4.37	14.26	39.34	46.00	6.66	QP
6	677.960	20.72	4.42	15.23	40.37	46.00	5.63	QP

Remarks: 1. Emission Level= Antenna Factor + Cable Loss + Reading.
 2. The emission levels that are 20dB below the official limit are not reported.

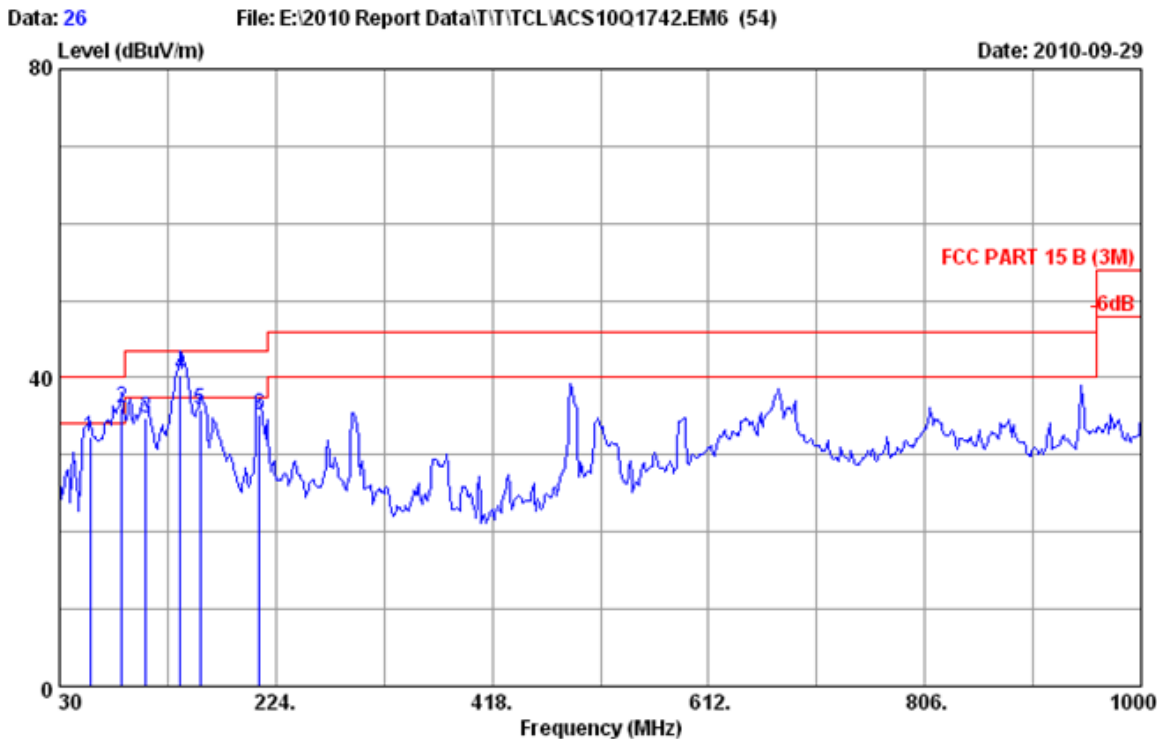

Site no. : 3m Chamber Data no. : 26
 Dis. / Ant. : 3m 2010 CBL6111C Ant. pol. : HORIZONTAL
 Limit : FCC PART 15 B (3M)
 Env. / Ins. : 24°C/56% Engineer : Victory
 EUT : LCD TV M/N:L40FHDF11TA
 Power rating : AC 120V/60Hz
 Test Mode : Running "H" Pattern And 1KHz Playing
 : HDMI2:1080P

No.	Freq. (MHz)	Ant. Factor (dB/m)	Cable Loss (dB)	Reading (dBuV)	Emission Level (dBuV/m)	Limits (dBuV/m)	Margin (dB)	Remark
1	57.160	6.66	0.83	24.79	32.28	40.00	7.72	QP
2	86.260	8.54	1.03	26.49	36.06	40.00	3.94	QP
3	107.600	11.20	1.12	22.40	34.72	43.50	8.78	QP
4	138.640	12.02	1.14	27.10	40.26	43.50	3.24	QP
5	156.100	11.26	1.21	23.32	35.79	43.50	7.71	QP
6	209.450	10.10	1.81	23.28	35.19	43.50	8.31	QP

Remarks: 1. Emission Level= Antenna Factor + Cable Loss + Reading.
 2. The emission levels that are 20dB below the official limit are not reported.

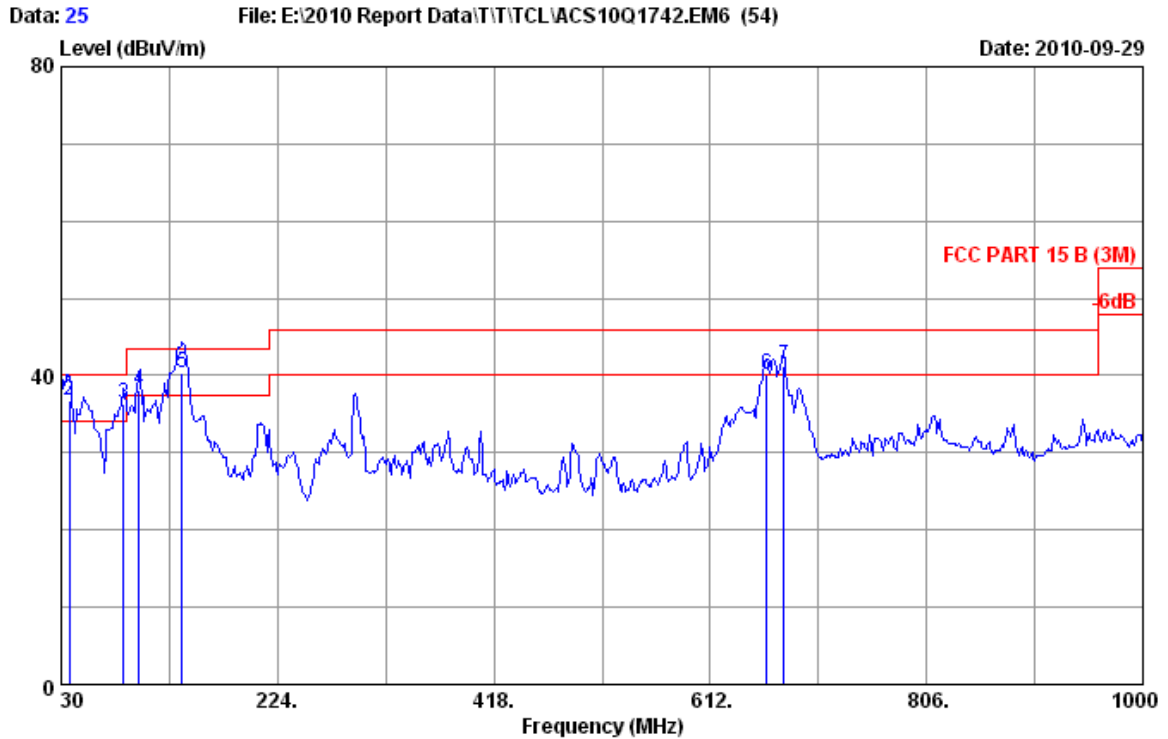

Site no. : 3m Chamber Data no. : 25
 Dis. / Ant. : 3m 2010 CBL6111C Ant. pol. : VERTICAL
 Limit : FCC PART 15 B (3M)
 Env. / Ins. : 24°C/56% Engineer : Victory
 EUT : LCD TV M/N:L40FHDF11TA
 Power rating : AC 120V/60Hz
 Test Mode : Running "H" Pattern And 1KHz Playing
 : HDMI2:1080P

No.	Freq. (MHz)	Ant. Factor (dB/m)	Cable Loss (dB)	Reading (dBUV)	Emission Level (dBUV/m)	Limits (dBUV/m)	Margin (dB)	Remark
1	30.000	20.00	0.61	15.70	36.31	40.00	3.69	QP
2	37.480	15.58	0.67	20.50	36.75	40.00	3.25	QP
3	86.260	8.54	1.03	26.84	36.41	40.00	3.59	QP
4	99.840	10.40	1.12	26.69	38.21	43.50	5.29	QP
5	138.640	12.02	1.14	27.18	40.34	43.50	3.16	QP
6	662.440	20.65	4.36	15.06	40.07	46.00	5.93	QP
7	677.960	20.72	4.42	16.01	41.15	46.00	4.85	QP

Remarks: 1. Emission Level= Antenna Factor + Cable Loss + Reading.
 2. The emission levels that are 20dB below the official limit are not reported.

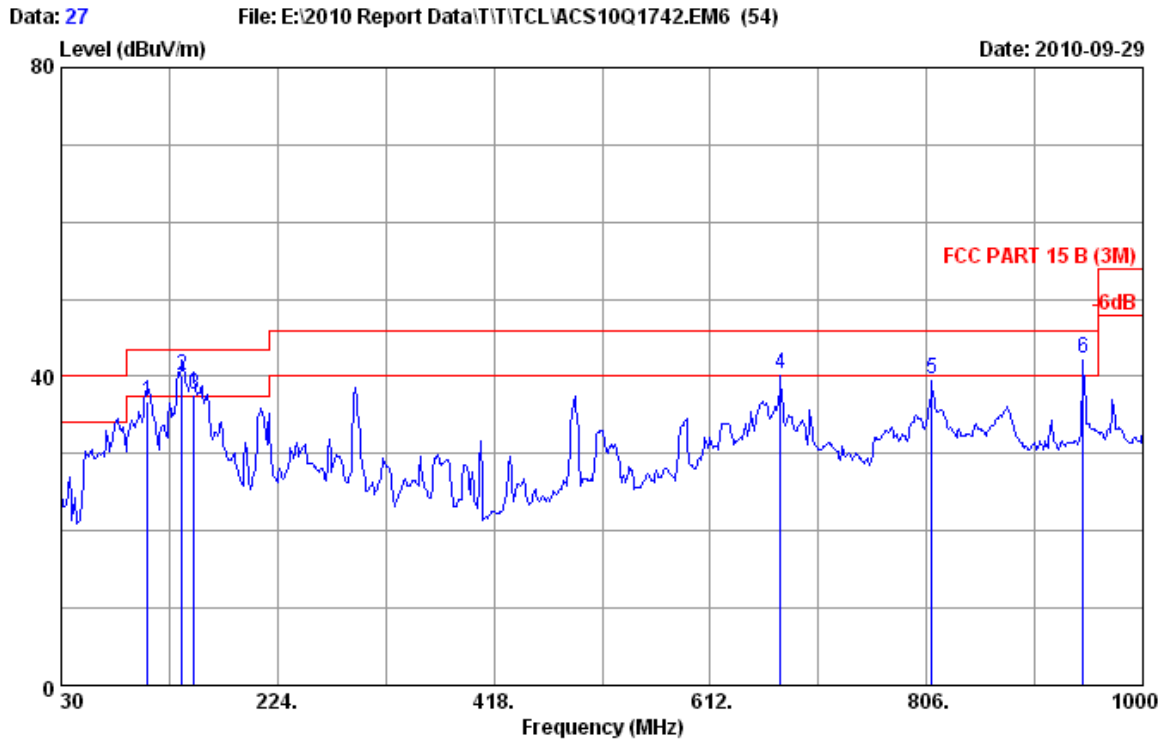

Site no. : 3m Chamber Data no. : 27
 Dis. / Ant. : 3m 2010 CBL6111C Ant. pol. : HORIZONTAL
 Limit : FCC PART 15 B (3M)
 Env. / Ins. : 24°C/56% Engineer : Victory
 EUT : LCD TV M/N:L40FHDF11TA
 Power rating : AC 120V/60Hz
 Test Mode : Running "H" Pattern And 1KHz Playing
 : HDMI3:1080P

No.	Freq. (MHz)	Ant. Factor (dB/m)	Cable Loss (dB)	Reading (dBUV)	Emission Level (dBUV/m)	Limits (dBUV/m)	Margin (dB)	Remark
1	107.600	11.20	1.12	24.53	36.85	43.50	6.65	QP
2	138.640	12.02	1.14	27.05	40.21	43.50	3.29	QP
3	149.310	11.66	1.14	24.77	37.57	43.50	5.93	QP
4	675.050	20.75	4.40	15.13	40.28	46.00	5.72	QP
5	810.850	22.02	4.93	12.80	39.75	46.00	6.25	QP
6	946.650	24.01	5.38	13.02	42.41	46.00	3.59	QP

Remarks: 1. Emission Level= Antenna Factor + Cable Loss + Reading.
 2. The emission levels that are 20dB below the official limit are not reported.

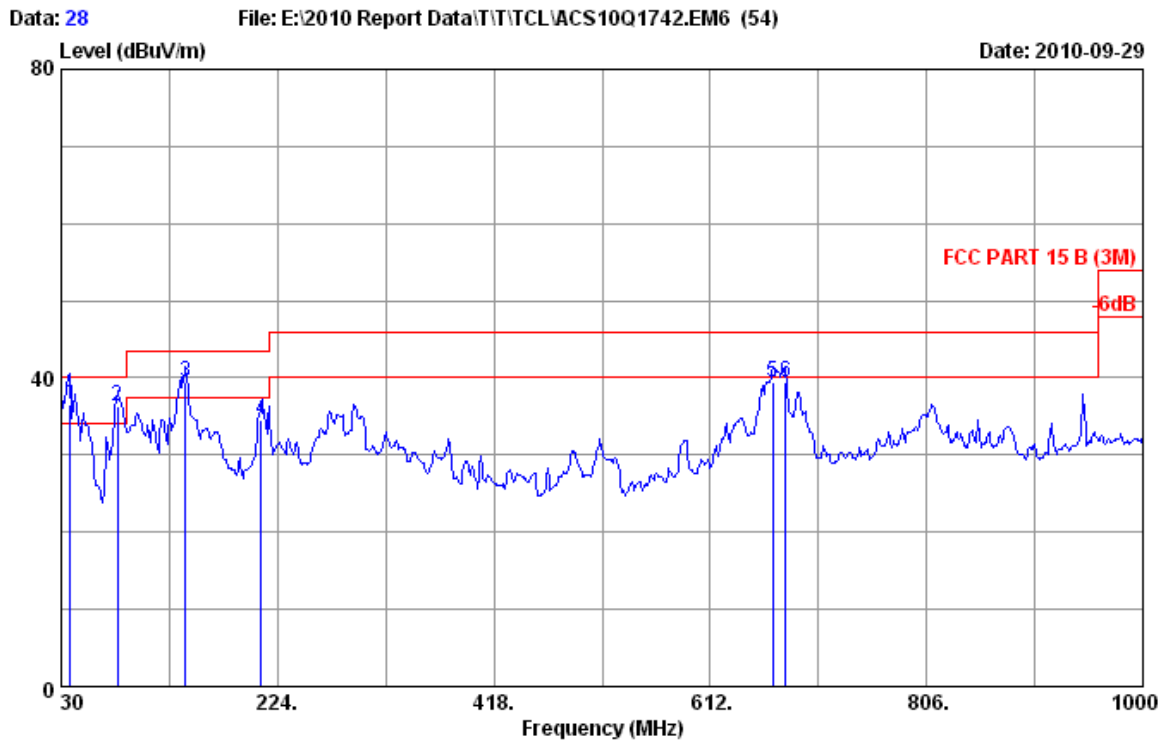

Site no. : 3m Chamber Data no. : 28
 Dis. / Ant. : 3m 2010 CBL6111C Ant. pol. : VERTICAL
 Limit : FCC PART 15 B (3M)
 Env. / Ins. : 24°C/56% Engineer : Victory
 EUT : LCD TV M/N:L40FHDF11TA
 Power rating : AC 120V/60Hz
 Test Mode : Running "H" Pattern And 1KHz Playing
 : HDMI3:1080P

No.	Freq. (MHz)	Ant. Factor (dB/m)	Cable Loss (dB)	Reading (dBUV)	Emission Level (dBUV/m)	Limits (dBUV/m)	Margin (dB)	Remark
1	37.760	15.58	0.67	20.30	36.55	40.00	3.45	QP
2	80.440	7.80	0.99	27.51	36.30	40.00	3.70	QP
3	141.550	11.97	1.14	26.39	39.50	43.50	4.00	QP
4	209.450	10.10	1.81	22.55	34.46	43.50	9.04	QP
5	668.260	20.76	4.38	14.33	39.47	46.00	6.53	QP
6	679.900	20.70	4.42	14.33	39.45	46.00	6.55	QP

Remarks: 1. Emission Level= Antenna Factor + Cable Loss + Reading.
 2. The emission levels that are 20dB below the official limit are not reported.

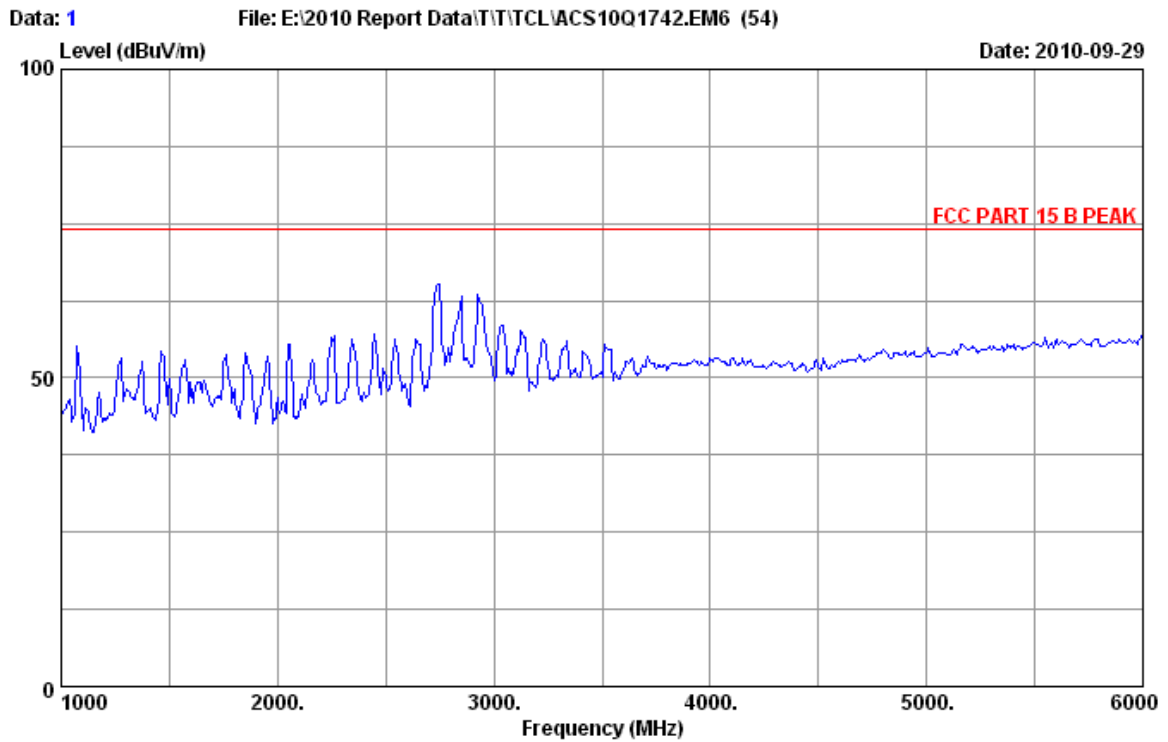

Site no.	: 3m Chamber	Data no.	: 1
Dis. / Ant.	: 3m 2009 3115	Ant. pol.	: HORIZONTAL
Limit	: FCC PART 15 B PEAK		
Env. / Ins.	: 24°C/56%	Engineer	: Victory
EUT	: LCD TV M/N:L40FHDF11TA		
Power Rating	: AC 120V/60Hz		
Test Mode	: Running "H" Pattern And 1KHz Playing		
	VGA:1024*768@60Hz		

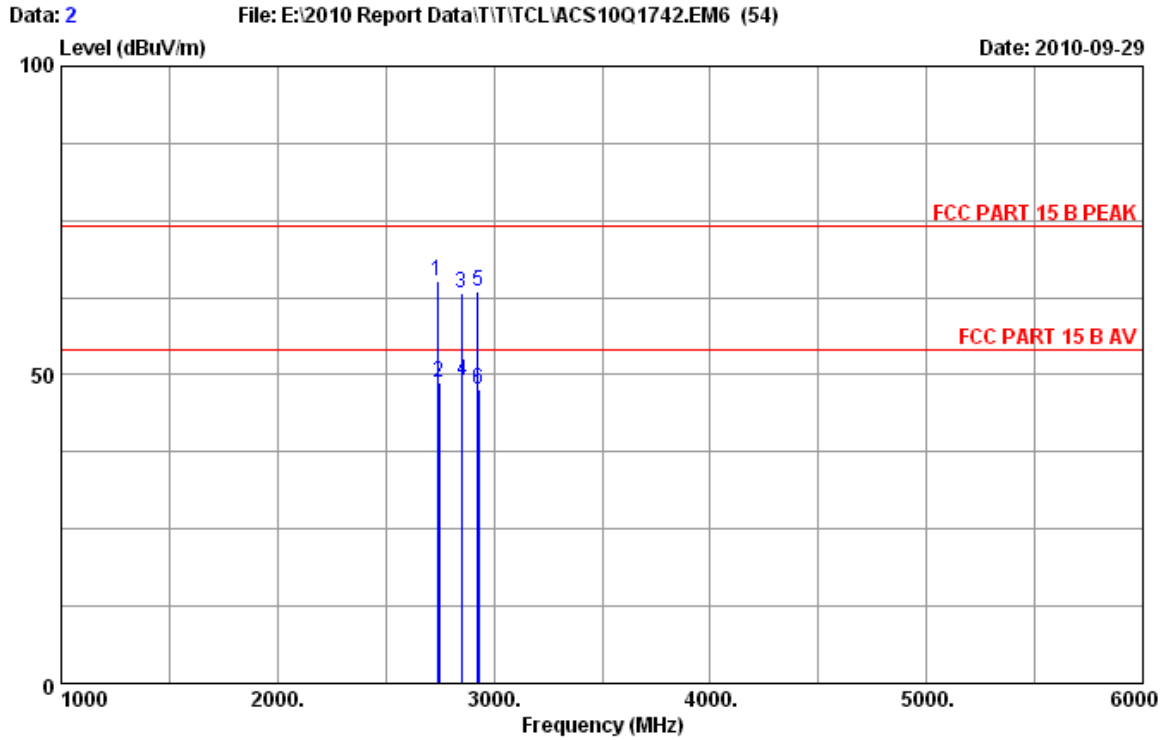

Site no. : 3m Chamber Data no. : 2
 Dis. / Ant. : 3m 2009 3115 Ant. pol. : HORIZONTAL
 Limit : FCC PART 15 B PEAK
 Env. / Ins. : 24°C/56% Engineer : Victory
 EUT : LCD TV M/N:L40FHDF11TA
 Power Rating : AC 120V/60Hz
 Test Mode : Running "H" Pattern And 1KHz Playing
 VGA:1024*768@60Hz

No.	Freq. (MHz)	Ant. Factor (dB/m)	Cable Loss (dB)	AMP factor (dBUV)	Reading (dBUV/m)	Emission Level (dBUV/m)	Limits (dB)	Margin (dB)	Remark
1	2740.000	30.05	6.32	33.72	62.65	65.30	74.00	8.70	Peak
2	2745.320	30.10	6.34	33.72	45.92	48.64	54.00	5.36	Average
3	2850.000	30.42	6.48	33.67	59.98	63.21	74.00	10.79	Peak
4	2852.570	30.42	6.48	33.67	45.84	49.07	54.00	4.93	Average
5	2925.000	30.63	6.57	33.64	59.94	63.50	74.00	10.50	Peak
6	2928.170	30.63	6.57	33.64	44.03	47.59	54.00	6.41	Average

Remarks: 1. Emission Level= Antenna Factor + Cable Loss + Reading - Amp Factor
 2. The emission levels that are 20dB below the official limit are not reported.

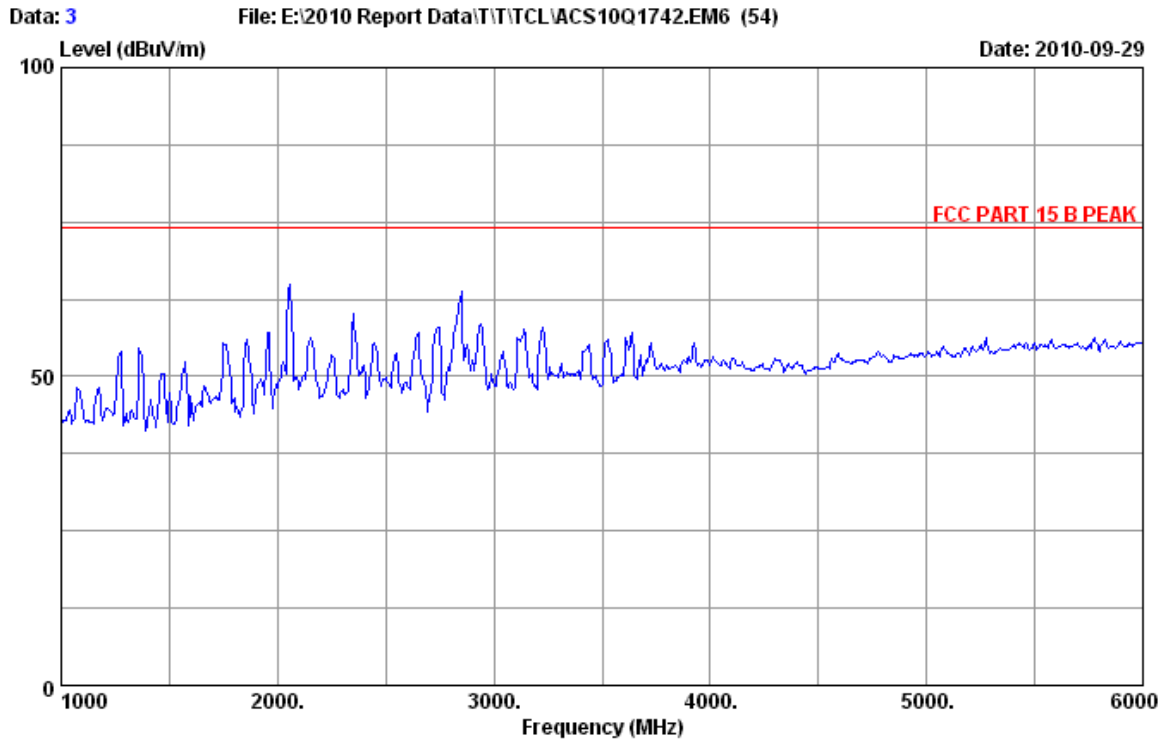

Site no. : 3m Chamber Data no. : 3
Dis. / Ant. : 3m 2009 3115 Ant. pol. : VERTICAL
Limit : FCC PART 15 B PEAK
Env. / Ins. : 24°C/56% Engineer : Victory
EUT : LCD TV M/N:L40FHDF11TA
Power Rating : AC 120V/60Hz
Test Mode : Running "H" Pattern And 1KHz Playing
VGA:1024*768@60Hz

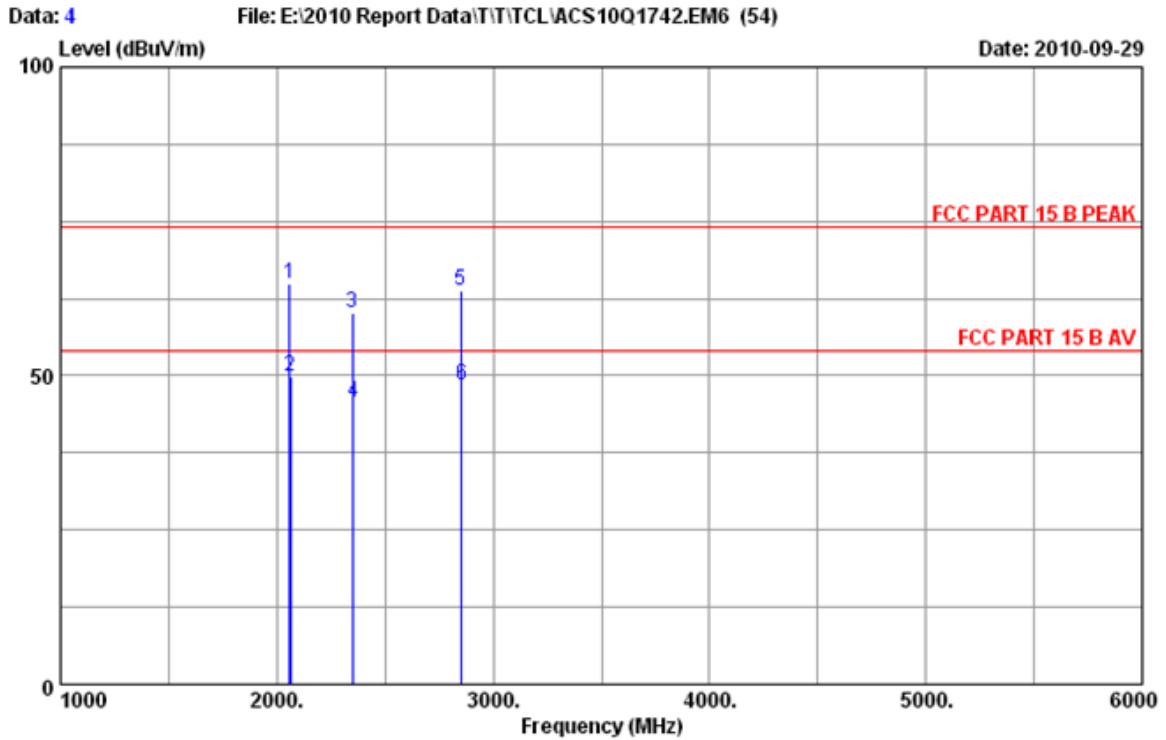

Site no. : 3m Chamber Data no. : 4
 Dis. / Ant. : 3m 2009 3115 Ant. pol. : VERTICAL
 Limit : FCC PART 15 B PEAK
 Env. / Ins. : 24°C/56% Engineer : Victory
 EUT : LCD TV M/N:L40FHDF11TA
 Power Rating : AC 120V/60Hz
 Test Mode : Running "H" Pattern And 1KHz Playing
 VGA:1024*768@60Hz

No.	Freq. (MHz)	Ant. Factor (dB/m)	Cable Loss (dB)	AMP factor (dBuV)	Reading (dBuV/m)	Emission Level (dBuV/m)	Limits (dB)	Margin (dB)	Remark
1	2060.000	26.61	5.39	34.07	67.06	64.99	74.00	9.01	Peak
2	2064.290	26.71	5.42	34.06	51.67	49.74	54.00	4.26	Average
3	2350.000	28.37	5.79	33.92	60.02	60.26	74.00	13.74	Peak
4	2354.740	28.47	5.81	33.92	45.23	45.59	54.00	8.41	Average
5	2850.000	30.42	6.48	33.67	60.54	63.77	74.00	10.23	Peak
6	2853.540	30.42	6.48	33.67	45.24	48.47	54.00	5.53	Average

Remarks: 1. Emission Level= Antenna Factor + Cable Loss + Reading - Amp Factor
 2. The emission levels that are 20dB below the official limit are not reported.

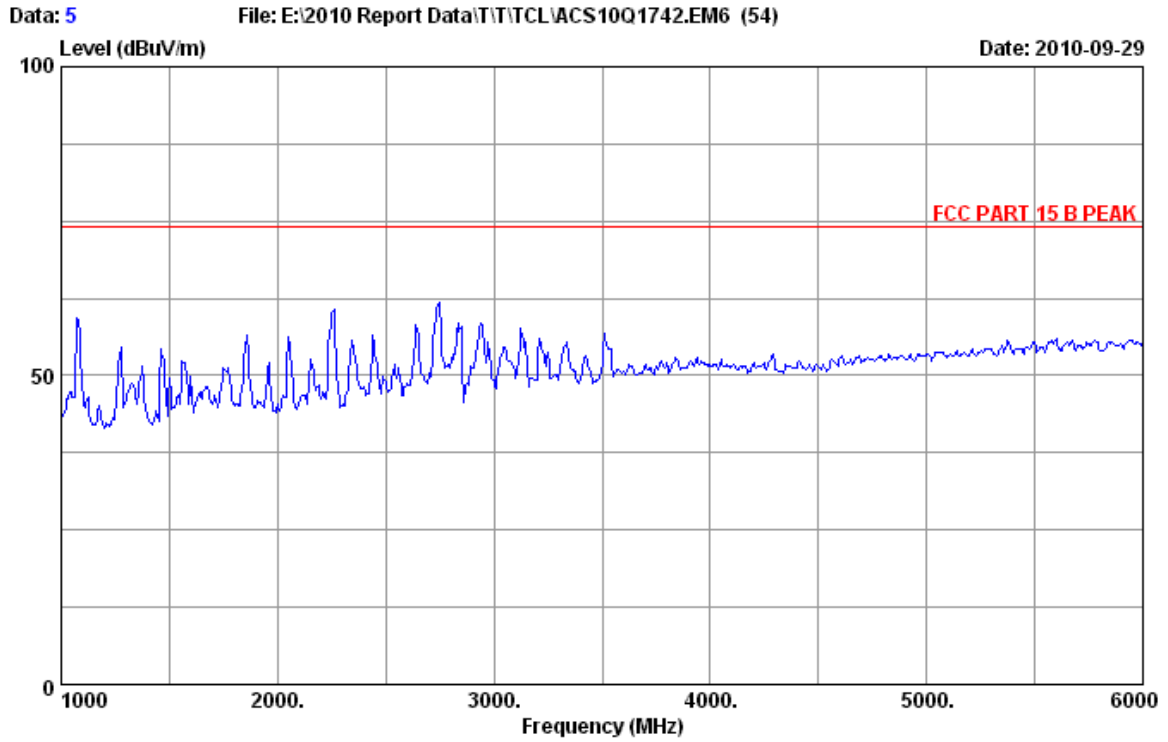

Site no. : 3m Chamber Data no. : 5
Dis. / Ant. : 3m 2009 3115 Ant. pol. : HORIZONTAL
Limit : FCC PART 15 B PEAK
Env. / Ins. : 24°C/56% Engineer : Victory
EUT : LCD TV M/N:L40FHDF11TA
Power Rating : AC 120V/60Hz
Test Mode : Running "H" Pattern And 1KHz Playing
HDMI1:1080P

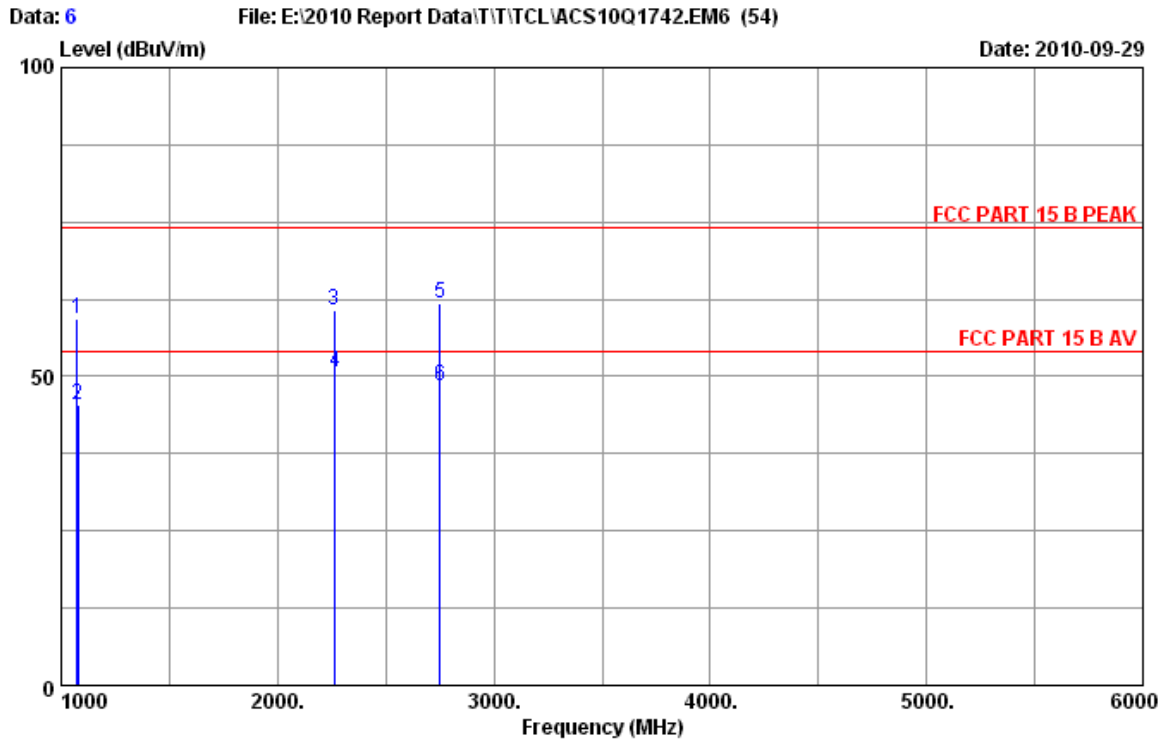

Site no. : 3m Chamber Data no. : 6
 Dis. / Ant. : 3m 2009 3115 Ant. pol. : HORIZONTAL
 Limit : FCC PART 15 B PEAK
 Env. / Ins. : 24°C/56% Engineer : Victory
 EUT : LCD TV M/N:L40FHDF11TA
 Power Rating : AC 120V/60Hz
 Test Mode : Running "H" Pattern And 1KHz Playing
 HDMI1:1080P

No.	Freq. (MHz)	Ant. Factor (dB/m)	Cable Loss (dB)	AMP factor (dBuV)	Reading (dBuV/m)	Emission Level (dBuV/m)	Limits (dB)	Margin (dB)	Remark
1	1075.000	25.37	4.05	36.51	66.56	59.47	74.00	14.53	Peak
2	1077.630	25.37	4.08	36.51	52.35	45.29	54.00	8.71	Average
3	2260.000	27.85	5.67	33.97	61.30	60.85	74.00	13.15	Peak
4	2264.520	27.85	5.67	33.96	51.03	50.59	54.00	3.41	Average
5	2750.000	30.10	6.34	33.72	59.00	61.72	74.00	12.28	Peak
6	2752.170	30.10	6.34	33.72	45.63	48.35	54.00	5.65	Average

Remarks: 1. Emission Level= Antenna Factor + Cable Loss + Reading - Amp Factor
 2. The emission levels that are 20dB below the official limit are not reported.

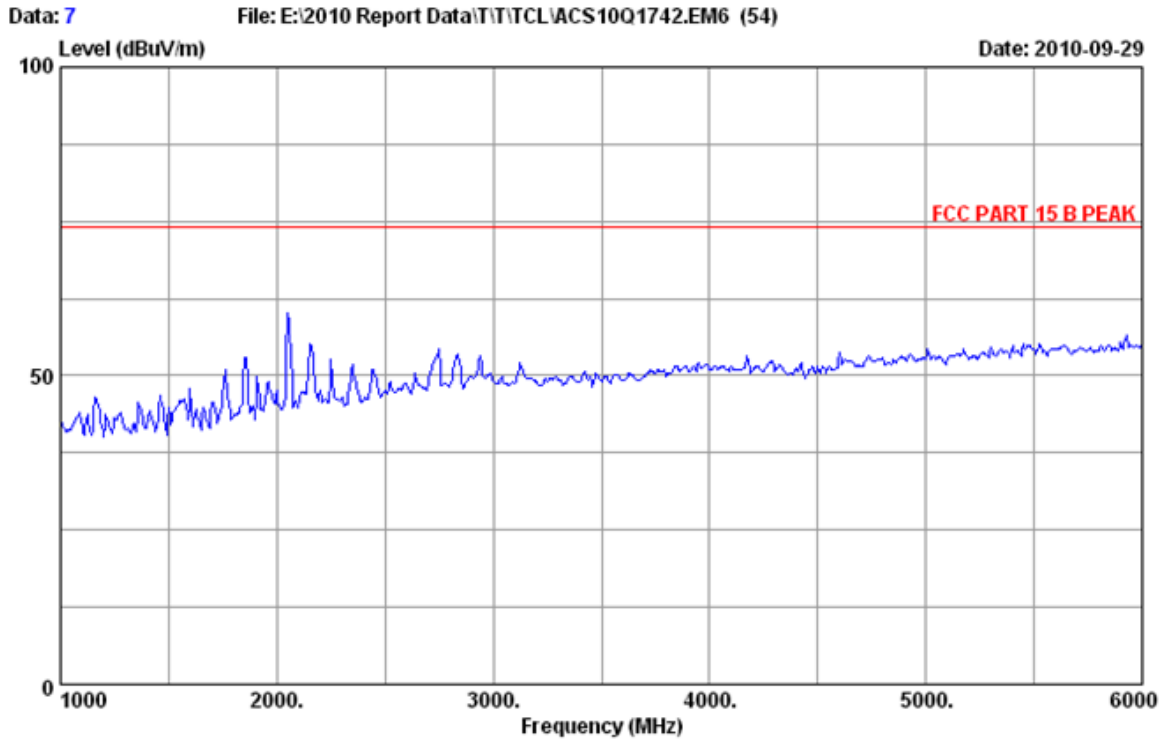

Site no.	: 3m Chamber	Data no.	: 7
Dis. / Ant.	: 3m 2009 3115	Ant. pol.	: VERTICAL
Limit	: FCC PART 15 B PEAK		
Env. / Ins.	: 24°C/56%	Engineer	: Victory
EUT	: LCD TV M/N:L40FHDF11TA		
Power Rating	: AC 120V/60Hz		
Test Mode	: Running "H" Pattern And 1KHz Playing		
	: HDMI1:1080P		

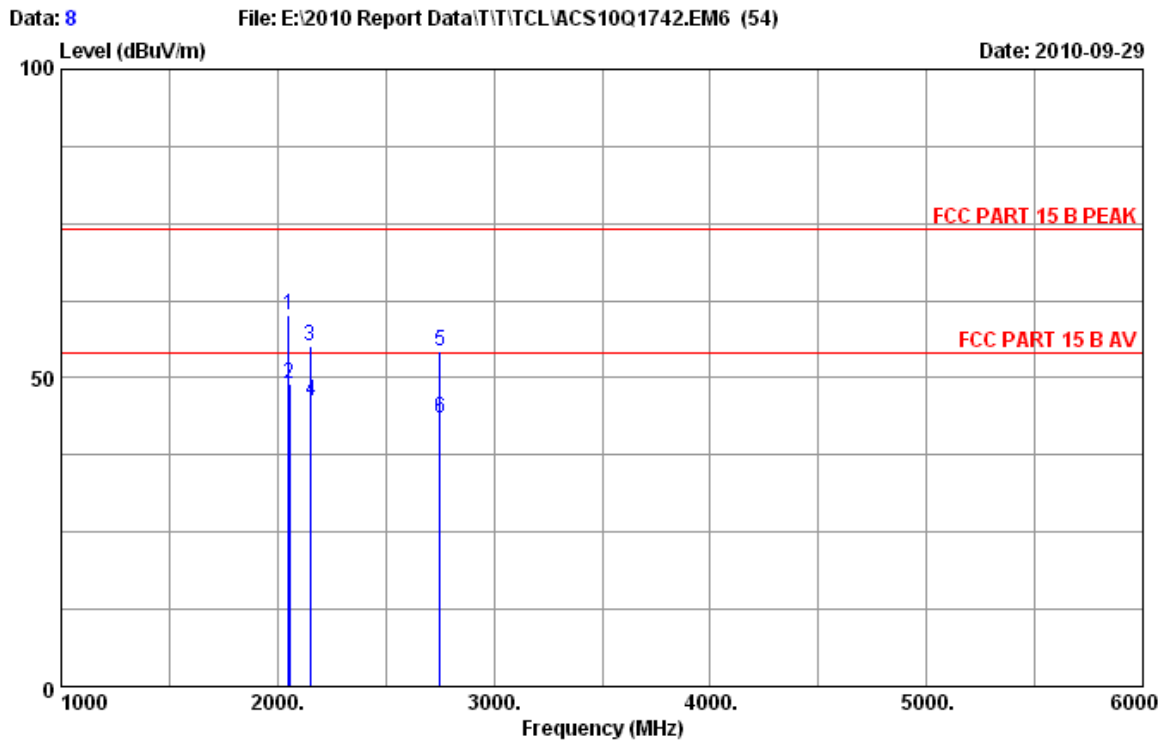

Site no. : 3m Chamber Data no. : 8
 Dis. / Ant. : 3m 2009 3115 Ant. pol. : VERTICAL
 Limit : FCC PART 15 B PEAK
 Env. / Ins. : 24°C/56% Engineer : Victory
 EUT : LCD TV M/N:L40FHDF11TA
 Power Rating : AC 120V/60Hz
 Test Mode : Running "H" Pattern And 1KHz Playing
 HDMI1:1080P

No.	Freq. (MHz)	Ant. Factor (dB/m)	Cable Loss (dB)	AMP factor (dBUV)	Reading (dBUV/m)	Emission Level (dBUV/m)	Limits (dB)	Margin (dB)	Remark
1	2050.000	26.61	5.39	34.07	62.22	60.15	74.00	13.85	Peak
2	2054.620	26.61	5.39	34.07	51.21	49.14	54.00	4.86	Average
3	2150.000	27.23	5.53	34.02	56.28	55.02	74.00	18.98	Peak
4	2153.420	27.23	5.53	34.02	47.62	46.36	54.00	7.64	Average
5	2750.000	30.10	6.34	33.72	51.65	54.37	74.00	19.63	Peak
6	2752.420	30.10	6.34	33.72	40.65	43.37	54.00	10.63	Average

Remarks: 1. Emission Level= Antenna Factor + Cable Loss + Reading - Amp Factor
 2. The emission levels that are 20dB below the official limit are not reported.

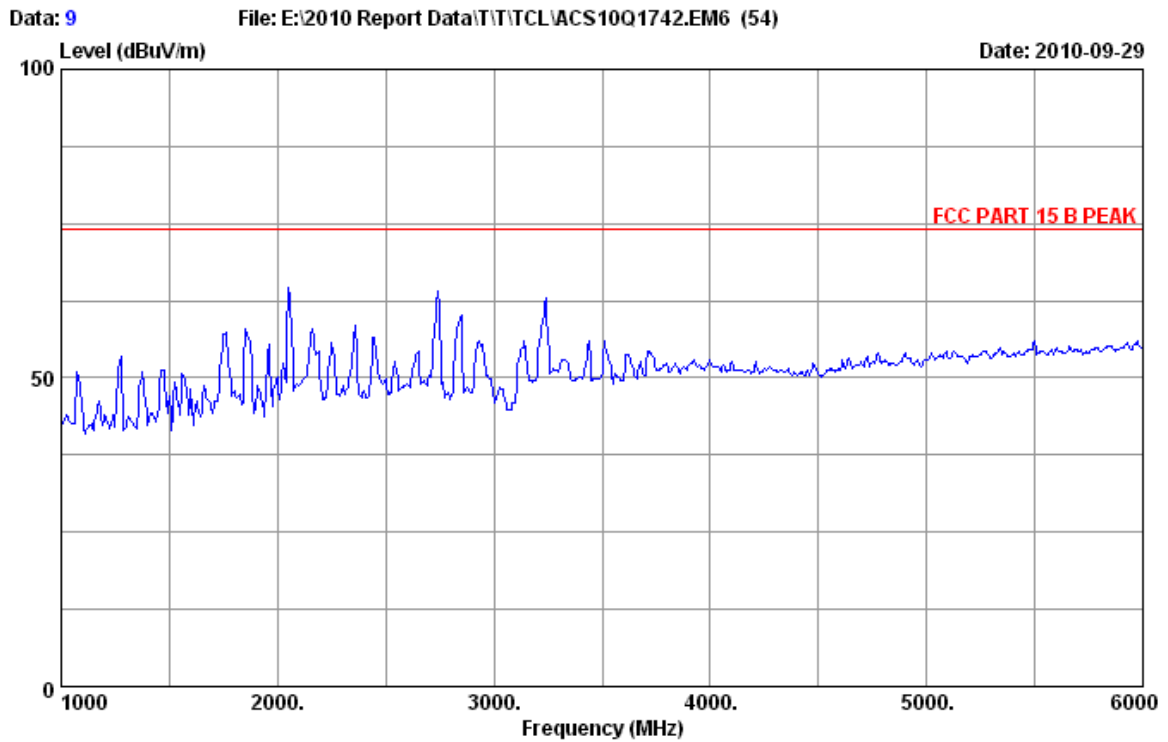

Site no.	: 3m Chamber	Data no.	: 9
Dis. / Ant.	: 3m 2009 3115	Ant. pol.	: VERTICAL
Limit	: FCC PART 15 B PEAK		
Env. / Ins.	: 24°C/56%	Engineer	: Victory
EUT	: LCD TV M/N:L40FHDF11TA		
Power Rating	: AC 120V/60Hz		
Test Mode	: Running "H" Pattern And 1KHz Playing		
	: HDMI2:1080P		

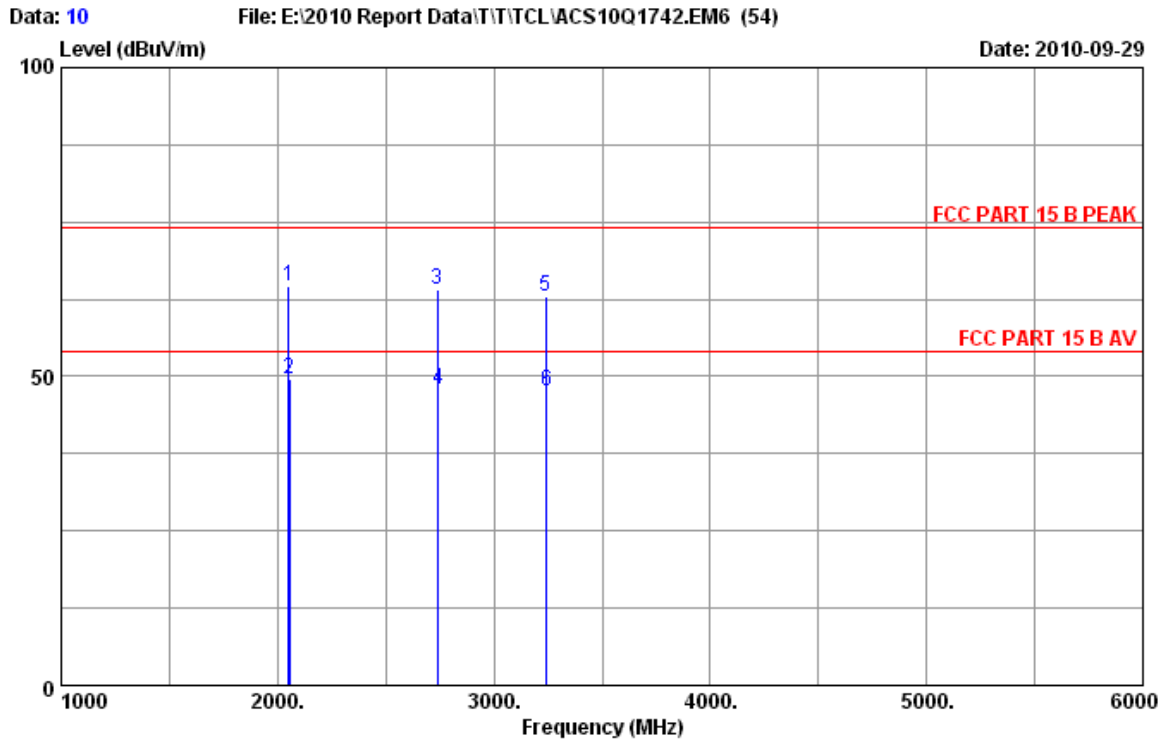

Site no. : 3m Chamber Data no. : 10
 Dis. / Ant. : 3m 2009 3115 Ant. pol. : VERTICAL
 Limit : FCC PART 15 B PEAK
 Env. / Ins. : 24°C/56% Engineer : Victory
 EUT : LCD TV M/N:L40FHDF11TA
 Power Rating : AC 120V/60Hz
 Test Mode : Running "H" Pattern And 1KHz Playing
 HDMI2:1080P

No.	Freq. (MHz)	Ant. Factor (dB/m)	Cable Loss (dB)	AMP factor (dBuV)	Reading (dBuV/m)	Emission Level (dBuV/m)	Limits (dB)	Margin (dB)	Remark
1	2050.000	26.61	5.39	34.07	66.60	64.53	74.00	9.47	Peak
2	2053.290	26.61	5.39	34.07	51.63	49.56	54.00	4.44	Average
3	2740.000	30.05	6.32	33.72	61.55	64.20	74.00	9.80	Peak
4	2744.520	30.10	6.34	33.72	45.21	47.93	54.00	6.07	Average
5	3240.000	31.09	6.88	33.47	58.49	62.99	74.00	11.01	Peak
6	3243.240	31.09	6.88	33.47	43.25	47.75	54.00	6.25	Average

Remarks: 1. Emission Level= Antenna Factor + Cable Loss + Reading - Amp Factor
 2. The emission levels that are 20dB below the official limit are not reported.

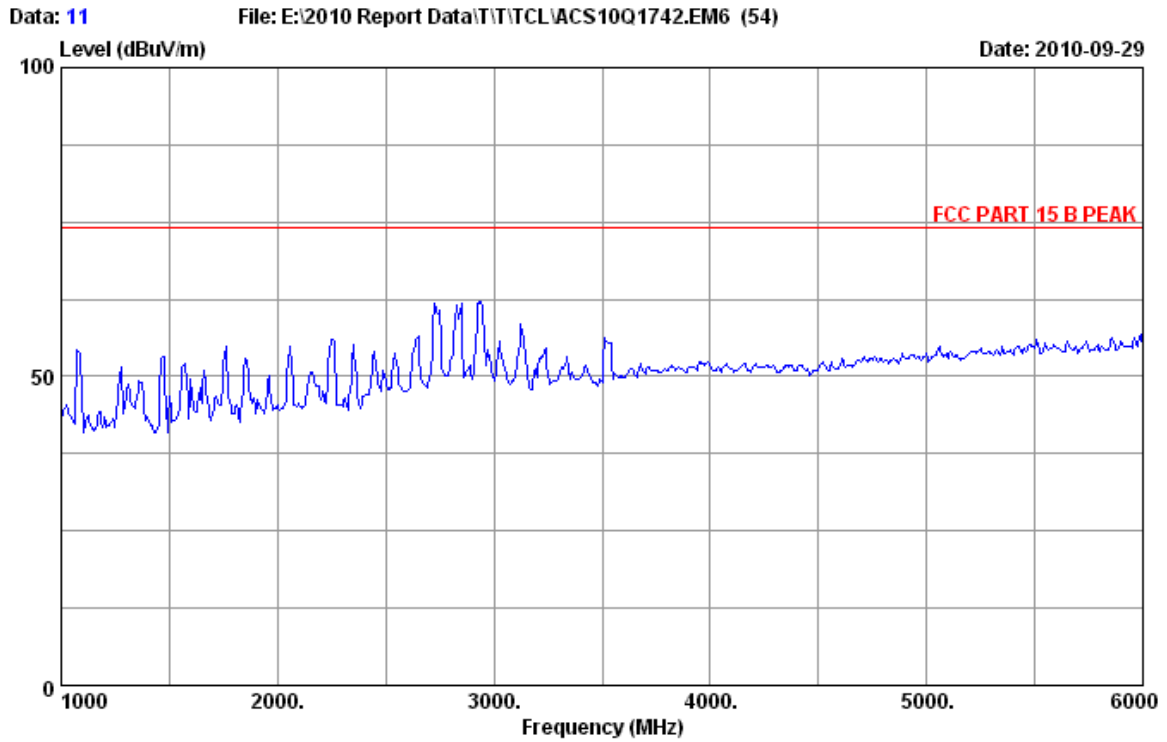

Site no.	: 3m Chamber	Data no.	: 11
Dis. / Ant.	: 3m 2009 3115	Ant. pol.	: HORIZONTAL
Limit	: FCC PART 15 B PEAK	Engineer	: Victory
Env. / Ins.	: 24°C/56%		
EUT	: LCD TV M/N:L40FHDF11TA		
Power Rating	: AC 120V/60Hz		
Test Mode	: Running "H" Pattern And 1KHz Playing		
	: HDMI2:1080P		

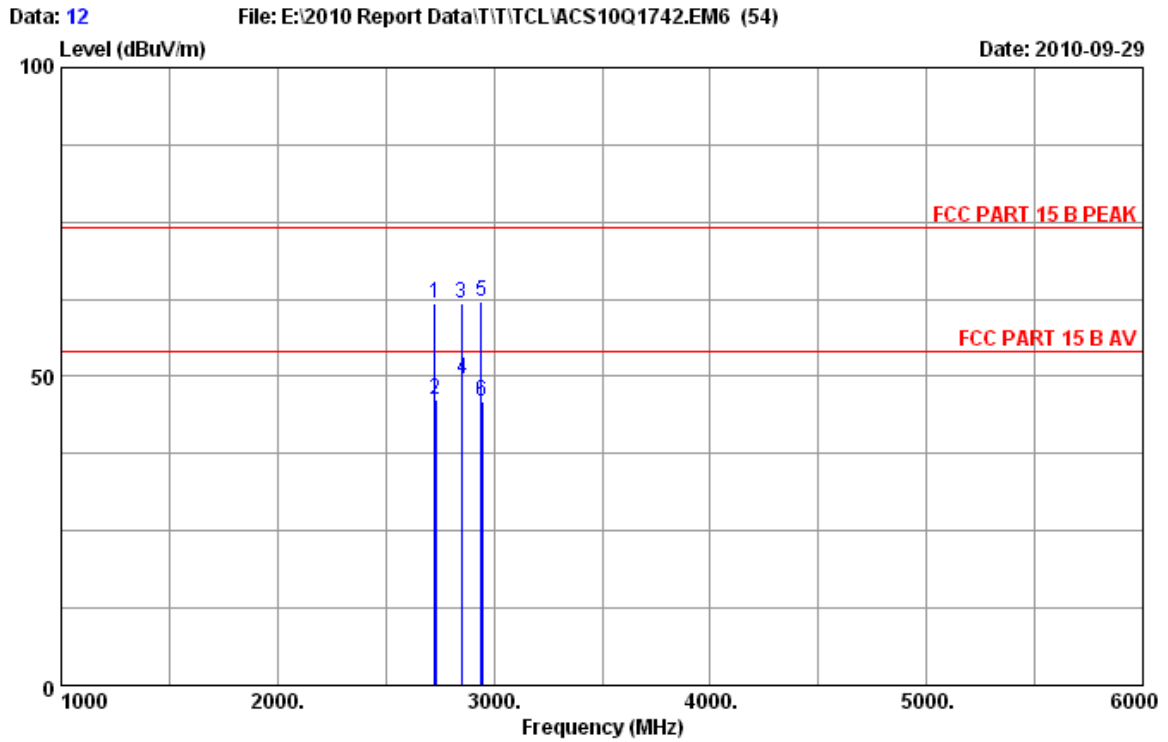

Site no. : 3m Chamber Data no. : 12
 Dis. / Ant. : 3m 2009 3115 Ant. pol. : HORIZONTAL
 Limit : FCC PART 15 B PEAK
 Env. / Ins. : 24°C/56% Engineer : Victory
 EUT : LCD TV M/N:L40FHDF11TA
 Power Rating : AC 120V/60Hz
 Test Mode : Running "H" Pattern And 1KHz Playing
 HDMI2:1080P

No.	Freq. (MHz)	Ant. Factor (dB/m)	Cable Loss (dB)	AMP factor (dBUV)	Reading (dBUV/m)	Emission Level (dBUV/m)	Limits (dB)	Margin (dB)	Remark
1	2725.000	29.99	6.30	33.74	59.21	61.76	74.00	12.24	Peak
2	2729.560	30.05	6.32	33.74	43.62	46.25	54.00	7.75	Average
3	2850.000	30.42	6.48	33.67	58.48	61.71	74.00	12.29	Peak
4	2853.190	30.42	6.48	33.67	46.22	49.45	54.00	4.55	Average
5	2940.000	30.69	6.60	33.62	58.42	62.09	74.00	11.91	Peak
6	2943.820	30.69	6.60	33.62	42.17	45.84	54.00	8.16	Average

Remarks: 1. Emission Level= Antenna Factor + Cable Loss + Reading - Amp Factor
 2. The emission levels that are 20dB below the official limit are not reported.

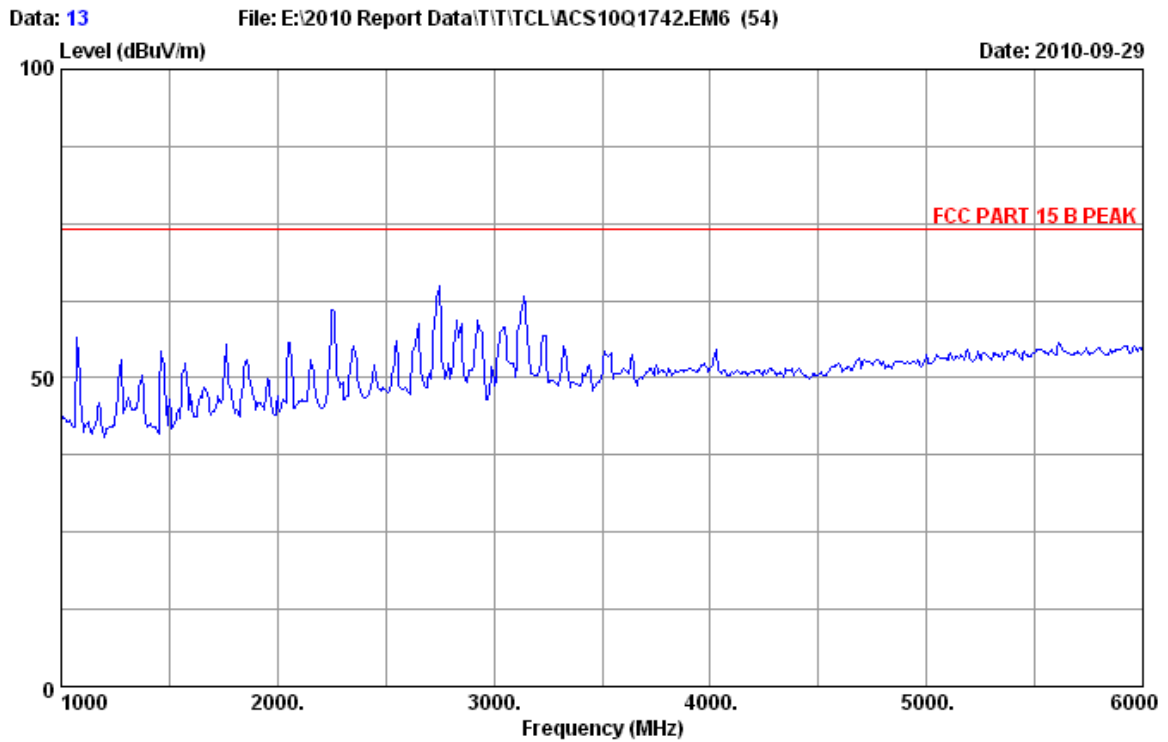

Site no.	: 3m Chamber	Data no.	: 13
Dis. / Ant.	: 3m 2009 3115	Ant. pol.	: HORIZONTAL
Limit	: FCC PART 15 B PEAK		
Env. / Ins.	: 24°C/56%	Engineer	: Victory
EUT	: LCD TV M/N:L40FHDF11TA		
Power Rating	: AC 120V/60Hz		
Test Mode	: Running "H" Pattern And 1KHz Playing		
	: HDMI3:1080P		

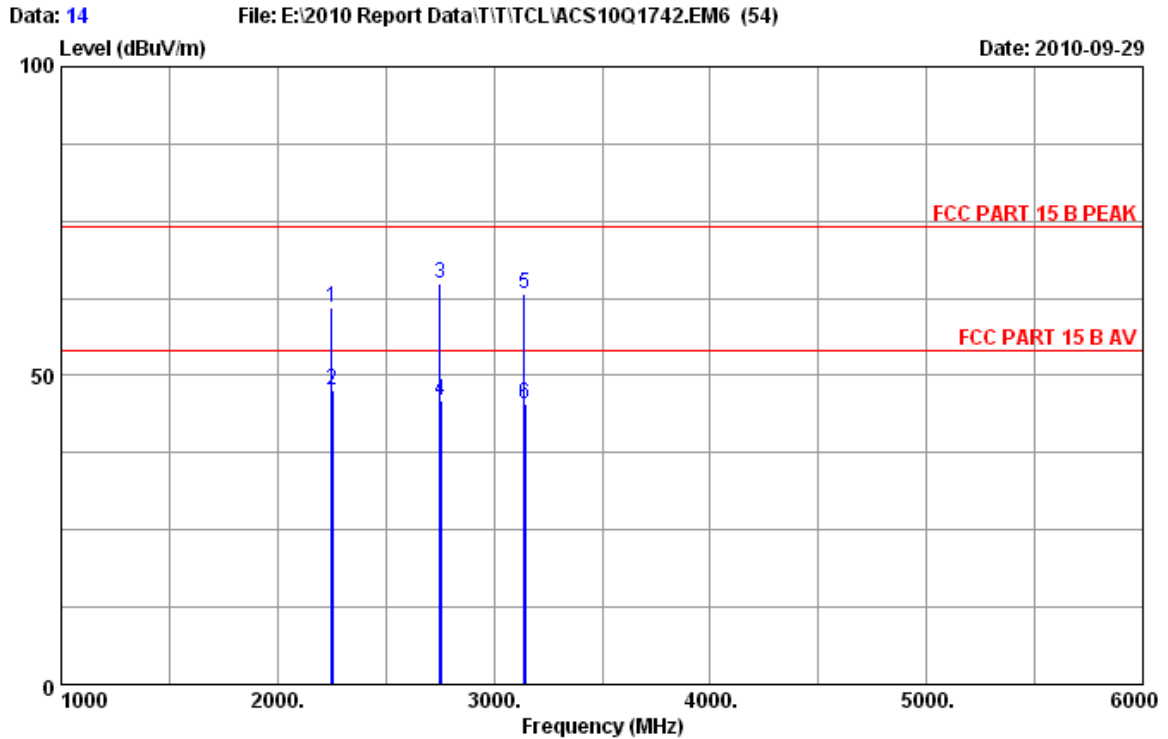

Site no. : 3m Chamber Data no. : 14
 Dis. / Ant. : 3m 2009 3115 Ant. pol. : HORIZONTAL
 Limit : FCC PART 15 B PEAK
 Env. / Ins. : 24°C/56% Engineer : Victory
 EUT : LCD TV M/N:L40FHDF11TA
 Power Rating : AC 120V/60Hz
 Test Mode : Running "H" Pattern And 1KHz Playing
 HDMI3:1080P

No.	Freq. (MHz)	Ant. Factor (dB/m)	Cable Loss (dB)	AMP factor (dBuV)	Reading (dBuV/m)	Emission Level (dBuV/m)	Limits (dB)	Margin (dB)	Remark
1	2250.000	27.85	5.67	33.97	61.53	61.08	74.00	12.92	Peak
2	2253.210	27.85	5.67	33.97	48.22	47.77	54.00	6.23	Average
3	2750.000	30.10	6.34	33.72	62.06	64.78	74.00	9.22	Peak
4	2754.120	30.10	6.34	33.72	43.28	46.00	54.00	8.00	Average
5	3140.000	31.01	6.80	33.52	59.04	63.33	74.00	10.67	Peak
6	3142.540	31.01	6.80	33.52	41.23	45.52	54.00	8.48	Average

Remarks: 1. Emission Level= Antenna Factor + Cable Loss + Reading - Amp Factor
 2. The emission levels that are 20dB below the official limit are not reported.

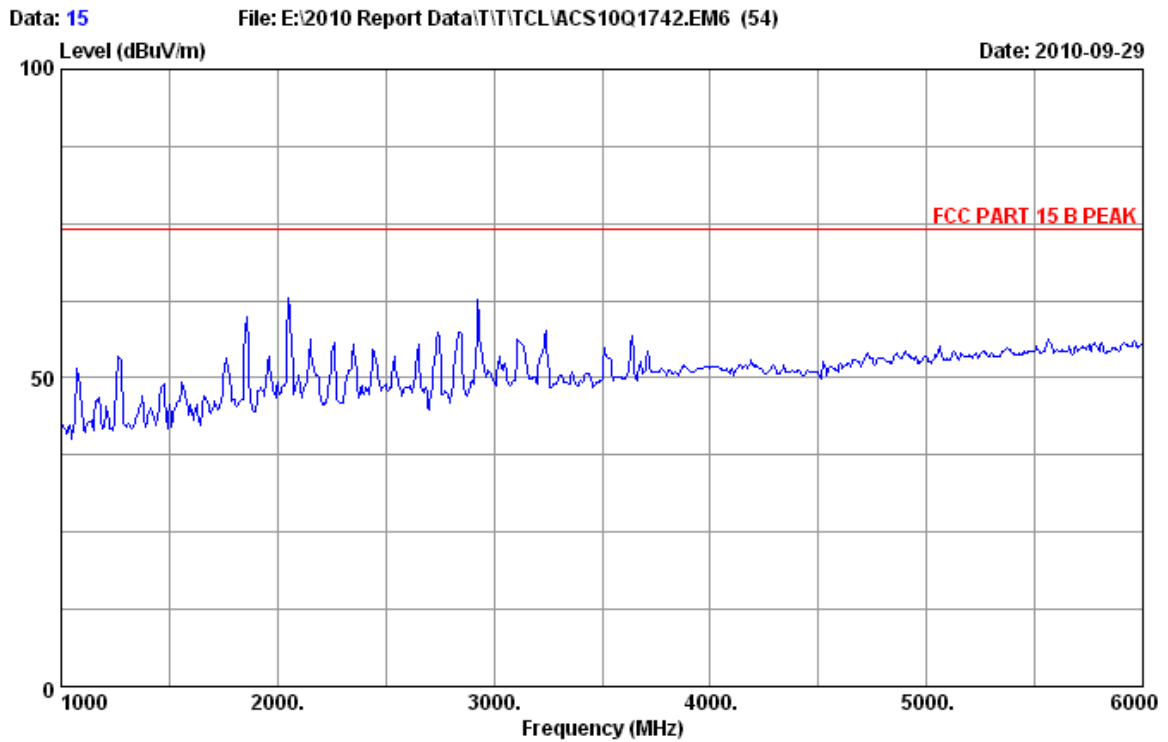

Site no.	: 3m Chamber	Data no.	: 15
Dis. / Ant.	: 3m 2009 3115	Ant. pol.	: VERTICAL
Limit	: FCC PART 15 B PEAK		
Env. / Ins.	: 24°C/56%	Engineer	: Victory
EUT	: LCD TV M/N:L40FHDF11TA		
Power Rating	: AC 120V/60Hz		
Test Mode	: Running "H" Pattern And 1KHz Playing		
	: HDMI3:1080P		

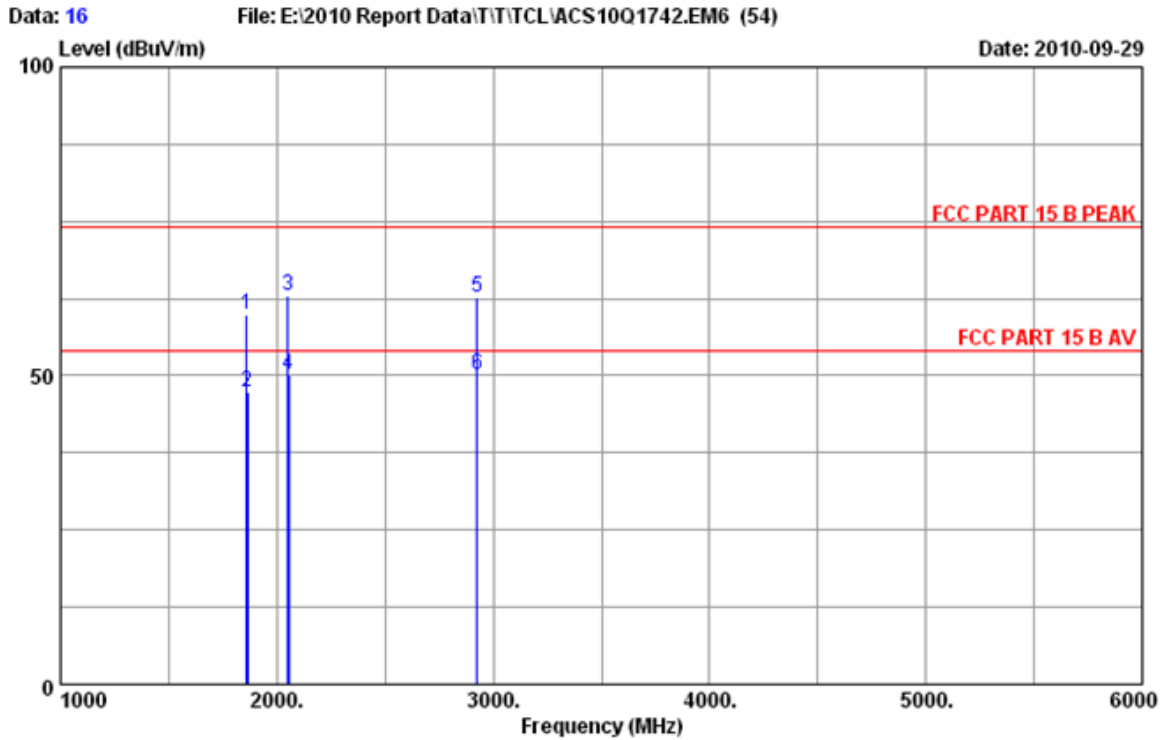

Site no. : 3m Chamber Data no. : 16
 Dis. / Ant. : 3m 2009 3115 Ant. pol. : VERTICAL
 Limit : FCC PART 15 B PEAK
 Env. / Ins. : 24°C/56% Engineer : Victory
 EUT : LCD TV M/N:L40FHDF11TA
 Power Rating : AC 120V/60Hz
 Test Mode : Running "H" Pattern And 1KHz Playing
 HDMI3:1080P

No.	Freq. (MHz)	Ant. Factor (dB/m)	Cable Loss (dB)	AMP factor (dBuV)	Reading (dBuV/m)	Emission Level (dBuV/m)	Limits (dB)	Margin (dB)	Remark
1	1860.000	26.01	5.14	34.49	63.18	59.84	74.00	14.16	Peak
2	1863.850	26.01	5.14	34.42	50.61	47.34	54.00	6.66	Average
3	2050.000	26.61	5.39	34.07	64.95	62.88	74.00	11.12	Peak
4	2055.140	26.61	5.39	34.07	52.27	50.20	54.00	3.80	Average
5	2925.000	30.63	6.57	33.64	59.07	62.63	74.00	11.37	Peak
6	2927.250	30.63	6.57	33.64	46.62	50.18	54.00	3.82	Average

Remarks: 1. Emission Level= Antenna Factor + Cable Loss + Reading - Amp Factor
 2. The emission levels that are 20dB below the official limit are not reported.