

APPLICATION OF CERTIFICATION  
For

TTE Technology Inc.

LCD TV

Brand Name	Model Number
RCA	L26HD41 L26HD31R

FCC ID: W8UL26HD31R

Prepared for : TTE Technology Inc.  
101 West 103rd Street, Indianapolis, IN 46290, United States

Prepared By: Audix Technology (Shenzhen) Co., Ltd.  
No. 6, Ke Feng Rd., 52 Block,  
Shenzhen Science & Industrial Park,  
Nantou, Shenzhen, Guangdong, China

Tel: (0755) 26639496  
Fax: (0755) 26632877

Report Number : ACS-F09052  
Date of Test : Feb.12~18, 2009  
Date of Report : Mar.19, 2009

## TABLE OF CONTENTS

<b>Description</b>	<b>Page</b>
<b>1. SUMMARY OF STANDARDS AND RESULTS .....</b>	<b>1-1</b>
1.1. Description of Standards and Results .....	1-1
<b>2. GENERAL INFORMATION.....</b>	<b>2-1</b>
2.1. Description of Device (EUT).....	2-1
2.2. Tested Supporting System Details .....	2-2
2.3. Test Facility .....	2-4
2.4. Measurement Uncertainty ( 95% confidence levels, k=2 ) .....	2-4
<b>3. POWER LINE CONDUCTED EMISSION TEST .....</b>	<b>3-1</b>
3.1. Test Equipment.....	3-1
3.2. Block Diagram of Test Setup.....	3-1
3.3. Power Line Conducted Emission Test Limits .....	3-1
3.4. Configuration of EUT on Test.....	3-2
3.5. Operating Condition of EUT .....	3-2
3.6. Test Procedure .....	3-2
3.7. Conducted Disturbance at Mains Terminals Test Results .....	3-3
<b>4. RADIATED EMISSION TEST.....</b>	<b>4-1</b>
4.1. Test Equipment.....	4-1
4.2. Block Diagram of Test Setup.....	4-1
4.3. Radiated Emission Limit .....	4-3
4.4. EUT Configuration on Test .....	4-3
4.5. Operating Condition of EUT .....	4-3
4.6. Test Procedure .....	4-3
4.7. Radiated Disturbance Test Results .....	4-4
<b>5. DEVIATION TO TEST SPECIFICATIONS .....</b>	<b>5-1</b>
<b>6. PHOTOGRAPH .....</b>	<b>6-1</b>
6.1. Photos of Power Line Conducted Emission Test.....	6-1
6.2. Photos of Radiated Emission Test (In Anechoic Chamber) .....	6-2
<b>7. PHOTOS OF THE EUT .....</b>	<b>7-3</b>

### TEST REPORT CERTIFICATION

Applicant : TTE Technology Inc.  
 Manufacturer #1 : TCL King Electrical Appliances (Huizhou) Co., Ltd.  
 Manufacturer #2 : Manufacturas Avanzadas S A  
 EUT Description : LCD TV  
 FCC ID : W8UL26HD31R

(A) MODEL NO.&  
 Brand Name :

Brand Name	Model Number
RCA	L26HD41 L26HD31R

(B) SERIAL NO. : N/A

(C) TEST VOLTAGE : AC 120V/60Hz

Measurement Standard Used:

FCC Rules and Regulations Part 15 Subpart B Class B 2008, ANSI C63.4-2003

The device described above is tested by Audix Technology (Shenzhen) Co., Ltd. to determine the maximum emission levels emanating from the device. The maximum emission levels are compared to the FCC Part 15 Subpart B Class B limits for radiated and conducted emissions. The test results are contained in this test report and Audix Technology (Shenzhen) Co., Ltd. is assumed full responsibility for the accuracy and completeness of tests. Also, this report shows that EUT is technically compliant with FCC requirements.

This report applies to above tested sample only. This report shall not be reproduced in parts without written approval of AUDIX TECHNOLOGY (SHENZHEN) CO., LTD.

Date of Test: Feb.12 18, 2009

Prepared by: Daisy Ye  
 Daisy Ye/ Assistant

Reviewer: Richzy

**AUDIX** 富華科技(深圳)有限公司  
 Audix Technology (Shenzhen) Co., Ltd.  
 EMC 部門報告專用章  
 Stamp only for EMC Dept. Report  
 Signature: Ken Lu 3/23/09

Approved & Authorized Signer: Ken Lu  
 Ken Lu / Manager

# 1. SUMMARY OF STANDARDS AND RESULTS

## 1.1. Description of Standards and Results

The EUT have been tested according to the applicable standards as referenced below.

<b>EMISSION</b>			
<b>Description of Test Item</b>	<b>Standard</b>	<b>Limits</b>	<b>Results</b>
Power Line Conducted Emission Test	FCC Part 15: 2008 ANSI C63.4: 2003	Class B	PASS
Radiated Emission Test	FCC Part 15: 2008 ANSI C63.4: 2003	Class B	PASS

## 2. GENERAL INFORMATION

### 2.1. Description of Device (EUT)

Description : LCD TV

Model Number :	Brand Name	Model Number
	RCA	L26HD41 L26HD31R

Test model: L26HD41

Only the appearance is different

Chassis : RS95

Power : PWL37C-03B

FCC ID : W8UL26HD31R

Applicant : TTE Technology Inc.  
101 West 103rd Street, Indianapolis, IN 46290, United States

Manufacturer #1 : TCL King Electrical Appliances (Huizhou) Co., Ltd.  
Section 19, Zhongkai Development Zone for New and High Level  
TECH Industries, Huizhou, Guangdong 516006, China

Manufacturer #2 : Manufacturas Avanzadas S A  
Parque Industrial Salvarcar, Blvd Independencia 2151,  
CD Juarez, Chih, Mexico

Power Cord : Unshielded, Detachable, 1.5m

Date of Test : Feb.12~18, 2009

Date of Receipt : Feb.12, 2009

Sample Type : Prototype production

## 2.2. Tested Supporting System Details

### 2.2.1. PC

EMC CODE : Test PC L  
M/N : CR6  
S/N : L38N404  
Manufacturer : Lenovo  
Power cord : Unshielded, detachable, 1.8m  
FCC ID : By DoC  
BSMI ID : R33B65

### 2.2.2. USB Keyboard

EMC CODE : ACS-EMC-K07R  
M/N : KU-0225  
SN : 0019402  
Manufacturer : Lenovo  
Data Cable : Shielded, Undetachable, 1.5m  
FCC ID : By DoC  
BSMI ID : R31310

### 2.2.3. PRINTER

EMC CODE : ACS-EMC-PT03  
M/N : EN8060A  
S/N : 908A1001201  
Manufacturer : OKIPAGE  
Data Cable : Shielded, Detachable, 1.5m  
Power Cord : Unshielded, Detachable, 1.8m  
FCC ID : By DoC  
BSMI ID : 3882A463

### 2.2.4. USB MOUSE

EMC CODE : ACS-EMC-M01R  
M/N : M056UO  
S/N : 512022645  
Manufacturer : Dell  
Data Cable : Shielded, Undetachable, 1.8m  
FCC ID : By DoC  
BSMI ID : R41108

## 2.2.5.HDD

EMC CODE : ACS-EMC-HDD01  
M/N : F12-UF  
S/N : A0100215-5390031  
Manufacturer : Terasys  
Data Cable : Shielded, Detachabled, 1.8m  
FCC ID : By DoC  
BSMI ID : 4912A022

## 2.2.6. HEADPHONE

EMC CODE : ACS-EMC-EP01  
M/N : OV880V  
Manufacturer : OVANN  
Data Cable : Shielded, Undetachabled, 4.0m

## 2.2.7. Cables

Audio Cable : Shielded, Detachabled, 1.8m  
VGA Cable : Shielded, Detachabled, 1.8m  
(With two cores)

### 2.3. Test Facility

#### Site Description

Name of Firm : Audix Technology (Shenzhen) Co., Ltd.  
No. 6, Ke Feng Rd., 52 Block, Shenzhen  
Science & Industrial Park, Nantou,  
Shenzhen, Guangdong, China

3m Anechoic Chamber : Jun. 13, 2006 File on Federal  
Communication Commission  
Registration Number: 90454

3m & 10m Anechoic Chamber : Jan. 31, 2007 File on Federal  
Communication Commission  
Registration Number: 794232

EMC Lab. : Accredited by DATech, German  
Registration Number: DAT-P-091/99-01  
Feb. 02, 2009

Accredited by NVLAP, USA  
NVLAP Code: 200372-0  
Apr. 01, 2008

### 2.4. Measurement Uncertainty ( 95% confidence levels, k=2 )

Test Item	Uncertainty	Memo
Uncertainty for Conduction emission test in No. 1 Conduction	2.88dB	
Uncertainty for Radiation Emission test in 3m chamber	3.86 dB	Polarize: V
	4.3 dB	Polarize: H
Uncertainty for Radiation Emission test in 10m chamber	3.82 dB	Distance: 3m Polarize: V
	3.80 dB	Distance: 3m Polarize: H
Uncertainty for test site temperature and humidity	0.1°C	
	1%	



### 3. POWER LINE CONDUCTED EMISSION TEST

#### 3.1. Test Equipment

Item	Equipment	Manufacturer	Model No.	Serial No.	Last Cal.	Cal. Interval
1.	Test Receiver	Rohde & Schwarz	ESCI	100843	Oct.24, 08	1 Year
2.	L.I.S.N.#2	Kyoritsu	KNW-407	8-1636-1	May 10,08	1 Year
3.	L.I.S.N.#3	Kyoritsu	KNW-242C	8-1920-1	May 10,08	1 Year
4.	Terminator	Hubersuhner	50Ω	No. 1	May 10,08	1 Year
5.	RF Cable	Fujikura	3D-2W	LISN Cable 1#	Nov.10, 08	1/2 Year
6.	Coaxial Switch	Anritsu	MP59B	M55367	Nov.10, 08	1/2 Year
7.	Pulse Limiter	Rohde & Schwarz	ESH3-Z2	100341	Nov.10, 08	1/2 Year

#### 3.2. Block Diagram of Test Setup

##### 3.2.1. Block diagram of connection between the EUT and simulators

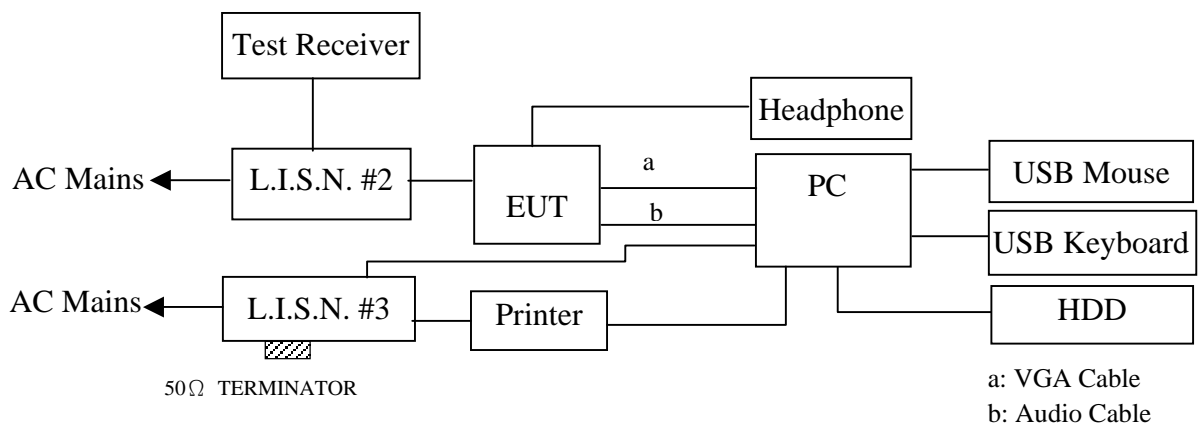

**(EUT: LCD TV)**

#### 3.3. Power Line Conducted Emission Test Limits

Frequency	Maximum RF Line Voltage	
	Quasi-Peak Level dB(μV)	Average Level dB(μV)
150kHz ~ 500kHz	66 ~ 56*	56 ~ 46*
500kHz ~ 5MHz	56	46
5MHz ~ 30MHz	60	50

Notes: 1. \* Decreasing linearly with logarithm of frequency.  
2. The lower limit shall apply at the transition frequencies.

### 3.4. Configuration of EUT on Test

The following equipment are installed on Power Line Conducted Emission Test to meet the commission requirement and operating regulations in a manner which tends to maximize its emission characteristics in a normal application.

#### 3.4.1. LCD TV (EUT)

Model Number : L26HD41  
Serial Number : N/A

3.4.2. Support Equipment : As Tested Supporting System Detail, in Section 2.2.

### 3.5. Operating Condition of EUT

3.5.1. Setup the EUT and simulator as shown as Section 3.2.

3.5.2. Turn on the power of all equipment.

3.5.3. Let the EUT work in test mode (Running “H” Pattern and Playing Music 640\*480 60Hz/ Running “H” Pattern and Playing Music 800\*600 60Hz/ Running “H” Pattern and Playing Music 1024\*768 60Hz) and measure it.

### 3.6. Test Procedure

The EUT was placed on a non-metallic table, 80cm above the ground plane. The EUT Power connected to the power mains through a line impedance stabilization network (L.I.S.N. 2#). This provided a 50-ohm coupling impedance for the EUT (Please refer to the block diagram of the test setup and photographs). The other peripheral devices power cord connected to the power mains through a line impedance stabilization network (L.I.S.N.#3). Both sides of power line were checked for maximum conducted interference. In order to find the maximum emission, the relative positions of equipments and all of the interface cables were changed according to ANSI C63.4-2003 on conducted Emission test.

The bandwidth of test receiver (R&S TEST RECEIVER ESCI) is set at 10kHz.

The frequency range from 150kHz to 30MHz is checked. The test result are reported on Section 3.7.

### 3.7. Conducted Disturbance at Mains Terminals Test Results

**PASS.** (All emissions not reported below are too low against the prescribed limits.)

The EUT with the following test modes was tested and selected (mode 1) to read Q.P values and Average values, all the test results are listed in next pages.

EUT: LCD TV

Model No. : L26HD41

Test Date: Feb.18, 2009

Temperature: 23°C

Humidity: 54%

The details of test modes are as follows :

NO.	Test Mode	Resolution & Frequency	Reference Test Data No.	
			VA	VB
1. ※	Running "H" Pattern and Playing Music	640*480 60Hz	#60	#59
2.		800*600 60Hz	#58	#57
3.		1024*768 60Hz	#55	#56

(※ Worst test mode)



NO.6 Ke Feng Road,Block 52,  
Shenzhen Science&Industry Park  
Nantou, Shenzhen,Guang dong, China.  
Tel:+86-755-26639495  
Fax:+86-755-26632877  
Postcode:518057

Data: 60

File: D:\DATA\2009 Report\T\TCL\ACS8Q2012.EMLEM6 (60)

Date: 2009-02-18

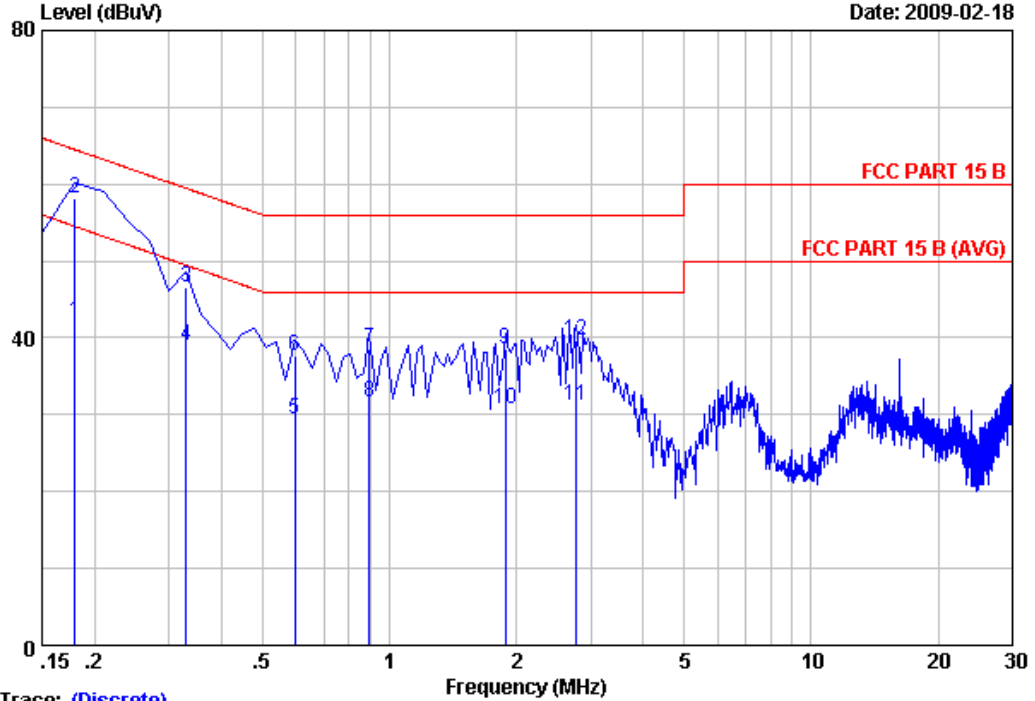

Trace: (Discrete)

Site no :Audix No.1 Conduction Data no :60  
Dis./Ant. \*\*: KNW407 1# VA  
Limit :FCC PART 15 B  
Env./Ins. :Temp:23'C Humi:54% Engineer :Leo  
EUT :LCD TV M/N:L26HD41  
Power Rating :AC 120V/60Hz  
Test Mode :Running "H" Pattern and playing Music  
:640\*480@60Hz  
:  
:

No	Freq (MHz)	LISN Factor (dB)	Cable Loss (dB)	Reading (dBuV)	Emission Level (dBuV)	Limits (dBuV)	Margin (dB)	Remark
1	0.17985	0.29	9.82	32.09	42.20	64.49	22.29	Average
2	0.17985	0.29	9.82	48.02	58.13	64.49	6.36	QP
3	0.32910	0.25	9.88	36.51	46.64	59.47	12.83	QP
4	0.32910	0.25	9.88	28.90	39.03	59.47	20.44	Average
5	0.59775	0.20	9.87	19.40	29.47	56.00	26.53	Average
6	0.59775	0.20	9.87	27.68	37.75	56.00	18.25	QP
7	0.89625	0.13	9.88	28.65	38.66	56.00	17.34	QP
8	0.89625	0.13	9.88	21.61	31.62	56.00	24.38	Average
9	1.881	0.10	9.90	28.59	38.59	56.00	17.41	QP
10	1.881	0.10	9.90	20.70	30.70	56.00	25.30	Average
11	2.777	0.10	9.91	21.30	31.31	56.00	24.69	Average
12	2.777	0.10	9.91	29.68	39.69	56.00	16.31	QP

Remarks: 1.Emission Level=LISN Factor+Cable Loss(Include 10dB pulse limit)+Reading  
2.If the average limit is met when using a quasi-peak detector, the EUT shall be deemed to meet both limits and measurement with average detector is unnecessary.



NO.6 Ke Feng Road,Block 52,  
Shenzhen Science&Industry Park  
Nantou, Shenzhen,Guang dong, China.  
Tel:+86-755-26639495  
Fax:+86-755-26632877  
Postcode:518057

Data: 59

File: D:\DATA\2009 Report\T\TCL\ACS8Q2012.EMLEM6 (60)

Date: 2009-02-18

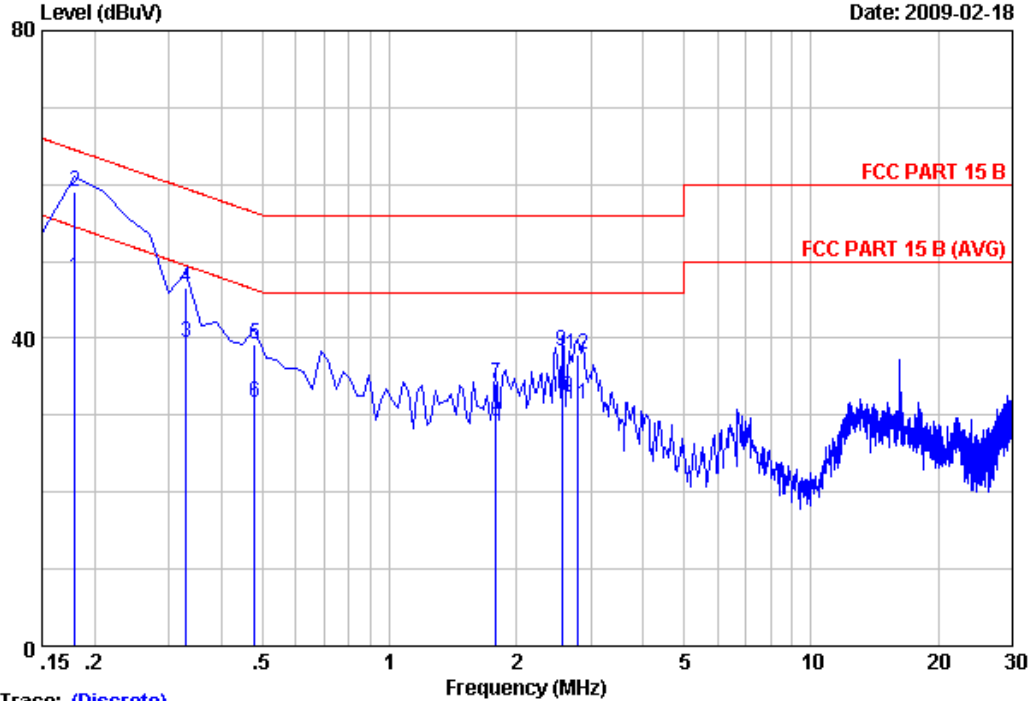

Trace: (Discrete)

Site no :Audix No.1 Conduction Data no :59  
Dis./Ant. \*\*: KNW407 1# VB  
Limit :FCC PART 15 B  
Env./Ins. :Temp:23'C Humi:54% Engineer :Leo  
EUT :LCD TV M/N:L26HD41  
Power Rating :AC 120V/60Hz  
Test Mode :Running "H" Pattern and playing Music  
:640\*480@60Hz  
:  
:

No	Freq (MHz)	LISN Factor (dB)	Cable Loss (dB)	Reading (dBuV)	Emission Level (dBuV)	Limits (dBuV)	Margin (dB)	Remark
1	0.17985	0.15	9.82	37.90	47.87	64.49	16.62	Average
2	0.17985	0.15	9.82	49.08	59.05	64.49	5.44	QP
3	0.32910	0.15	9.88	29.41	39.44	59.47	20.03	Average
4	0.32910	0.15	9.88	36.65	46.68	59.47	12.79	QP
5	0.47835	0.20	9.87	29.12	39.19	56.37	17.18	QP
6	0.47835	0.20	9.87	21.49	31.56	56.37	24.81	Average
7	1.792	0.04	9.90	24.06	34.00	56.00	22.00	QP
8	1.792	0.04	9.90	19.30	29.24	56.00	26.76	Average
9	2.568	0.03	9.91	28.36	38.30	56.00	17.70	QP
10	2.568	0.03	9.91	22.40	32.34	56.00	23.66	Average
11	2.807	0.03	9.91	21.50	31.44	56.00	24.56	Average
12	2.807	0.03	9.91	27.86	37.80	56.00	18.20	QP

Remarks: 1.Emission Level=LISN Factor+Cable Loss(Include 10dB pulse limit)+Reading  
2.If the average limit is met when using a quasi-peak detector.  
the EUT shall be deemed to meet both limits and measurement  
with average detector is unnecessary.



NO.6 Ke Feng Road,Block 52,  
Shenzhen Science&Industry Park  
Nantou, Shenzhen,Guang dong, China.  
Tel:+86-755-26639495  
Fax:+86-755-26632877  
Postcode:518057

Data: 58 File: D:\DATA\2009 Report\TTC\ACS8Q2012.EMLEM6 (60)

Date: 2009-02-18

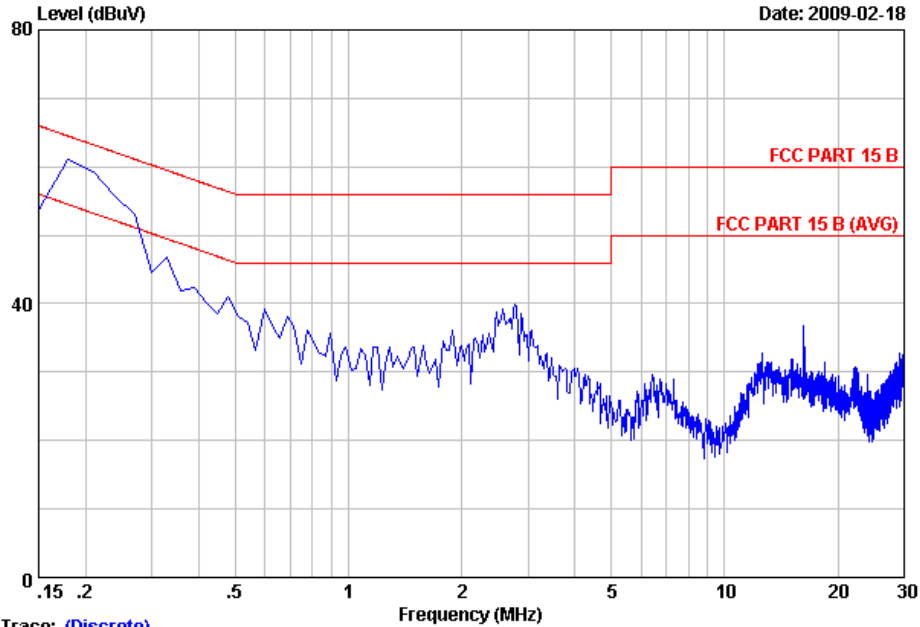

Trace: (Discrete)

Site no :Audix No.1 Conduction Data no :58  
Dis./Ant. \*\*: KNW407 1# VA  
Limit :FCC PART 15 B  
Env./Ins. :Temp:23'C Humi:54% Engineer :Leo  
EUT :LCD TV M/N:L26HD41  
Power Rating :AC 120V/60Hz  
Test Mode :Running "H" Pattern and playing Music  
:800\*600@60Hz

Data: 57 File: D:\DATA\2009 Report\TTC\ACS8Q2012.EMLEM6 (60)

Date: 2009-02-18

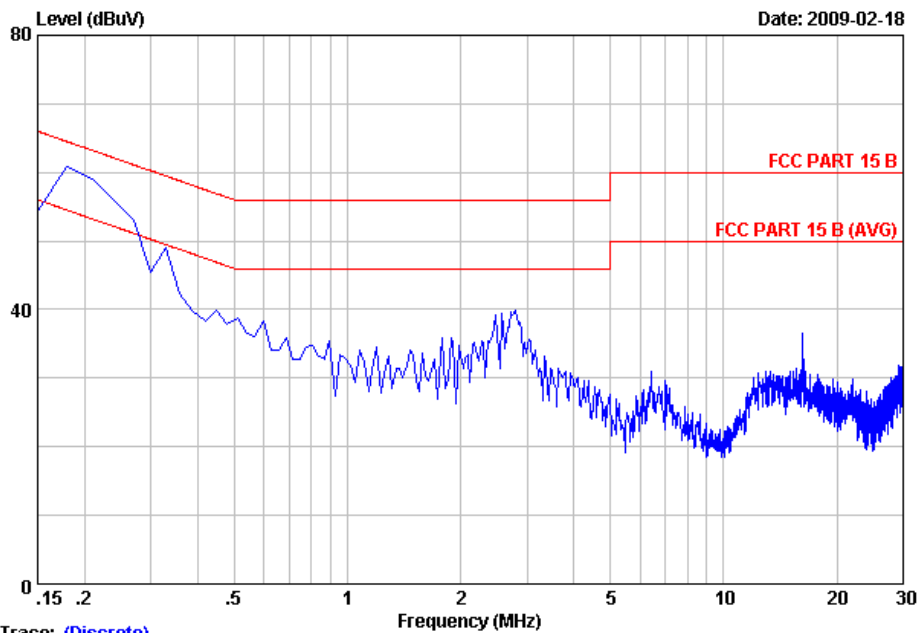

Trace: (Discrete)

Site no :Audix No.1 Conduction Data no :57  
Dis./Ant. \*\*: KNW407 1# VB  
Limit :FCC PART 15 B  
Env./Ins. :Temp:23'C Humi:54% Engineer :Leo  
EUT :LCD TV M/N:L26HD41  
Power Rating :AC 120V/60Hz  
Test Mode :Running "H" Pattern and playing Music  
:800\*600@60Hz



NO.6 Ke Feng Road,Block 52,  
Shenzhen Science&Industry Park  
Nantou, Shenzhen,Guang dong, China.  
Tel:+86-755-26639495  
Fax:+86-755-26632877  
Postcode:518057

Data: 55 File: D:\DATA\2009 Report\T\TCL\ACS8Q2012.EMLEM6 (60) Date: 2009-02-18

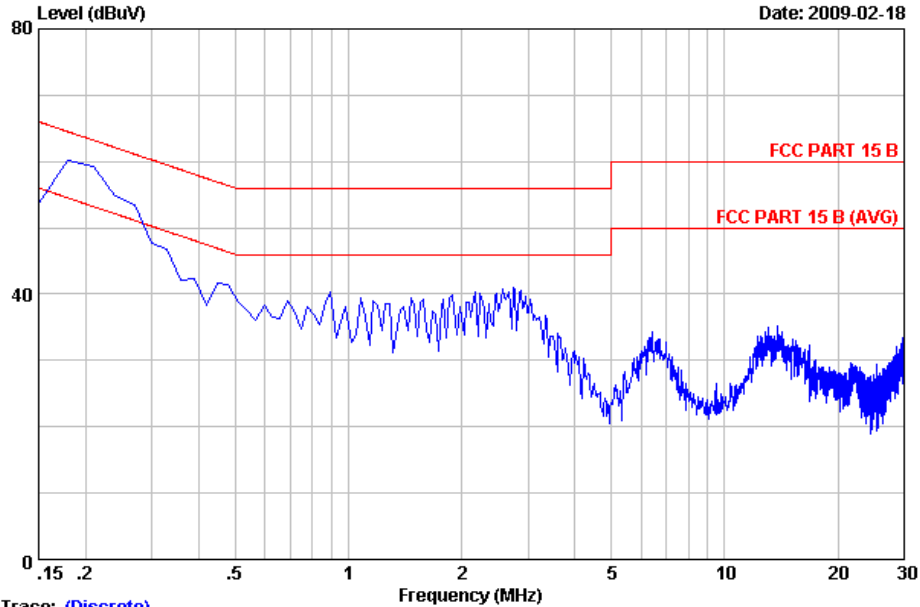

Trace: (Discrete)

Site no :Audix No.1 Conduction Data no :55  
Dis./Ant. \*\*: KNW407 1# VA  
Limit :FCC PART 15 B  
Env./Ins. :Temp:23'C Humi:54% Engineer :Leo  
EUT :LCD TV M/N:L26HD41  
Power Rating :AC 120V/60Hz  
Test Mode :Running "H" Pattern and playing Music  
:1024\*768@60Hz

Data: 56 File: D:\DATA\2009 Report\T\TCL\ACS8Q2012.EMLEM6 (60) Date: 2009-02-18

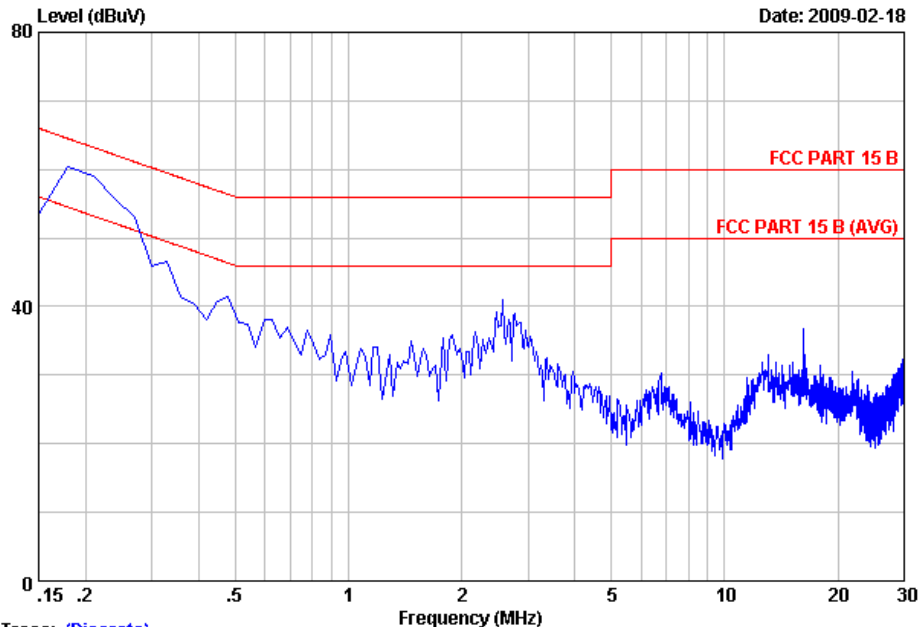

Trace: (Discrete)

Site no :Audix No.1 Conduction Data no :56  
Dis./Ant. \*\*: KNW407 1# VB  
Limit :FCC PART 15 B  
Env./Ins. :Temp:23'C Humi:54% Engineer :Leo  
EUT :LCD TV M/N:L26HD41  
Power Rating :AC 120V/60Hz  
Test Mode :Running "H" Pattern and playing Music  
:1024\*768@60Hz

## 4. RADIATED EMISSION TEST

### 4.1. Test Equipment

For frequency range 30MHz~1000MHz (At Anechoic Chamber)

Item	Equipment	Manufacturer	Model No.	Serial No.	Last Cal.	Cal. Interval
1	3#Chamber	AUDIX	N/A	N/A	Dec.05,08	1/2 Year
2	EMI Spectrum	Agilent	E4407B	MY41440292	May 10, 08	1 Year
3	Test Receiver	Rohde & Schwarz	ESVS10	834468/011	May 10, 08	1 Year
4	Amplifier	HP	8447D	2648A04738	Nov.04, 08	1/2 Year
5	Bilog Antenna	Schaffner	CBL6111C	2598	Nov.10, 08	1 Year
6	RF Cable	JINGCHENG	JBY400	3# Chamber No.1	Nov.01, 08	1/2 Year
7	RF Cable	JINGCHENG	JBY400	3# Chamber No.2	Nov.01, 08	1/2 Year
8	RF Cable	JINGCHENG	JBY400	3# Chamber No.3	Nov.01, 08	1/2 Year
9	RF Cable	JINGCHENG	JBY400	3# Chamber No.4	Nov.01, 08	1/2 Year
10	Coaxial Switch	Anritsu	MP59B	M73989	Nov.01, 08	1/2 Year

For frequency range Above 1000MHz (At Anechoic Chamber)

Item	Equipment	Manufacturer	Model No.	Serial No.	Last Cal.	Cal. Interval
1	Spectrum Analyzer	Agilent	E4446A	US44300459	May.10, 08	1 Year
2	Horn Antenna	EMCO	3115	9607-4877	May.27, 08	1.5 Year
3	Amplifier	Agilent	8449B	3008A02495	Nov.24,08	1 Year
4	RF Cable	Hubersuhner	SUCOFLEX102	28620/2	May.28, 08	1 Year
5	RF Cable	Hubersuhner	SUCOFLEX102	271471/4	May.28, 08	1 Year
6	RF Cable	Hubersuhner	SUCOFLEX102	29086/2	May.28, 08	1 Year

### 4.2. Block Diagram of Test Setup

#### 4.2.1. Block diagram of connection between the EUT and simulators

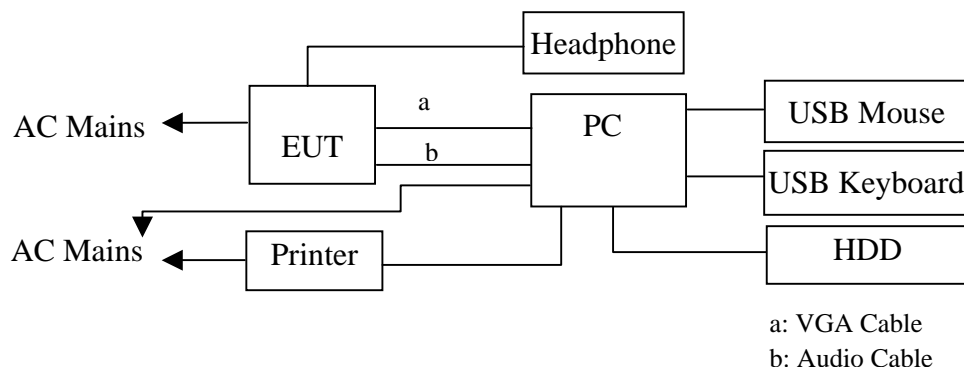

**(EUT: LCD TV)**



4.2.2. In Anechoic (3m) Chamber Test Setup Diagram for 30MHz~1000MHz

ANTENNA TOWER

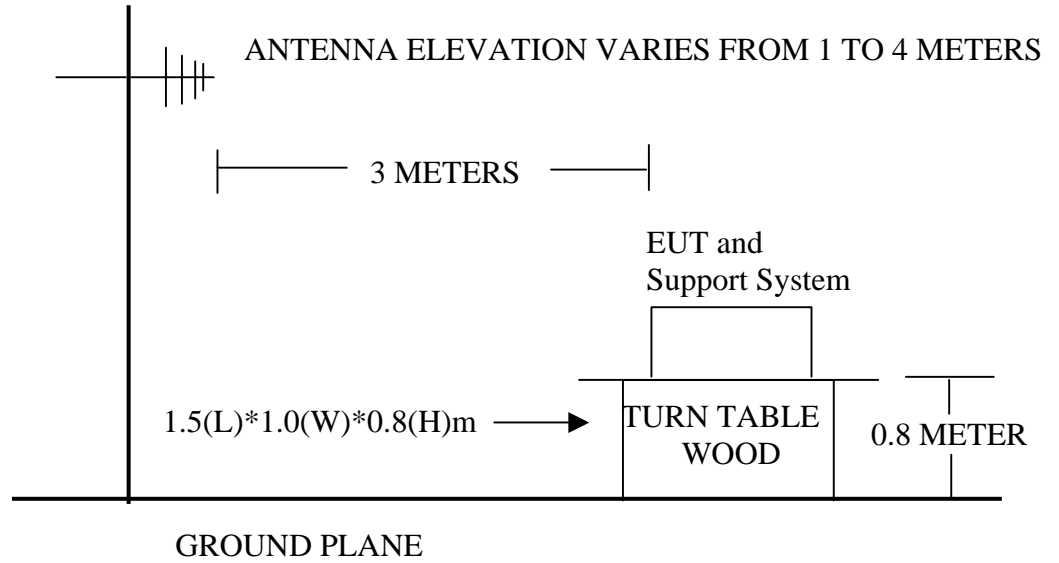

4.2.3. In Anechoic (10m) Chamber Test Setup Diagram for 1-2GHz

ANTENNA TOWER

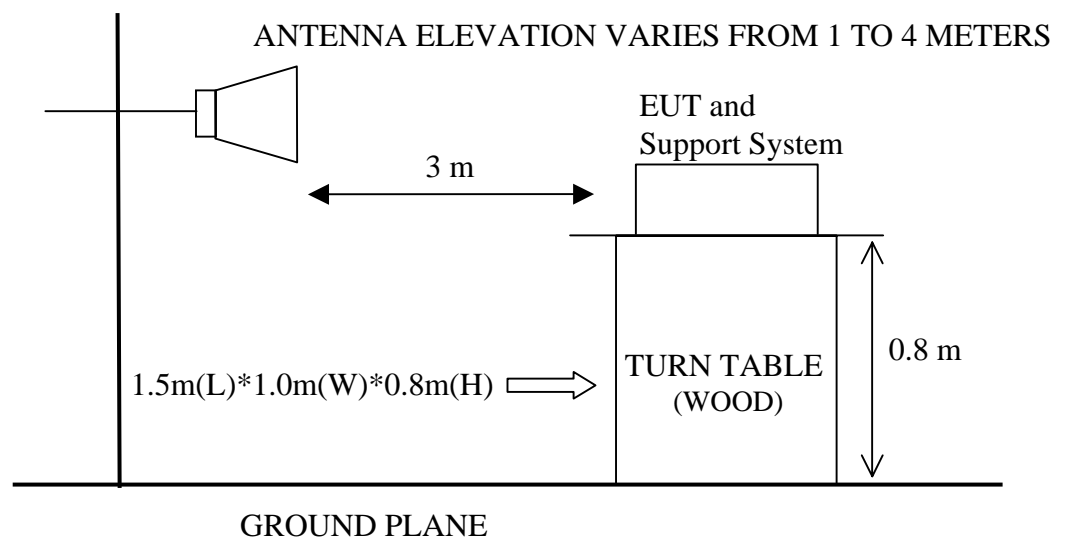

### 4.3. Radiated Emission Limit

Frequency MHz	Distance (Meters)	Field Strengths Limits dB( $\mu$ V)/m
30 ~ 88	3	40.0
88 ~ 216	3	43.5
216 ~ 960	3	46.0
960 ~ 1000	3	54.0
Above 1000	3	74.0 dB( $\mu$ V)/m (Peak) 54.0 dB( $\mu$ V)/m (Average)

- Remark :
- (1) Emission level  $\text{dB}\mu\text{V} = 20 \log \text{Emission level } \mu\text{V}/\text{m}$
  - (2) The smaller limit shall apply at the cross point between two frequency bands.
  - (3) The emissions above 1GHz should comply with average limit and peak limit.

### 4.4. EUT Configuration on Test

The following equipment are installed on Radiated Emission Test to meet the commission requirements and operating regulations in a manner that tends to maximize its emission characteristics in normal application.

#### 4.4.1. LCD TV (EUT)

Model Number : L26HD41  
Serial Number : N/A

### 4.5. Operating Condition of EUT

4.5.1. Setup the EUT as shown in Section 4.2.

4.5.2. Turn on the power of all equipment.

4.5.3. Let the EUT work in test mode (Running "H" Pattern and Playing Music 640\*480 60Hz/ Running "H" Pattern and Playing Music 800\*600 60Hz / Running "H" Pattern and Playing Music 1024\*768 60Hz) and test it.

### 4.6. Test Procedure

The EUT was placed on a non-metallic table, 80 cm above the ground plane inside a semi-anechoic chamber. An antenna was located 3m from the EUT on an adjustable mast. A pre-scan was first performed in order to find prominent radiated emissions. For final emissions measurements at each frequency of interest, the EUT were rotated and the antenna height was varied between 1m and 4m in order to maximize the emission. Measurements in both horizontal and vertical polarities were made and the data was recorded. In order to find the maximum emission, the relative positions of equipments and all of the interface cables were changed according to ANSI C63.4-2003 on Radiated Emission test.

The bandwidth setting on the test receiver (R&S TEST RECEIVER ESVS10) is 120 kHz.

The resolution bandwidth of the Agilent Spectrum Analyzer E4446A was set at 1MHz. (For above 1GHz)

The frequency range from 30MHz to 1000MHz was pre-scanned with a peak detector and all final readings of measurement from Test Receiver are Quasi-Peak values.

The frequency range from 1GHz to 2GHz was checked with peak and average detector, measurement distance is 3m in 10m chamber.

Finally, selected operating situations at Anechoic Chamber measurement, all the test results are listed in section 4.7.

#### 4.7. Radiated Disturbance Test Results

**PASS.** (All emissions not reported below are too low against the prescribed limits.)

##### **For frequency range 30MHz~1000MHz**

The EUT with the following test modes was tested and selected (mode 3) to read Q.P values, all the test results are listed in next pages.

EUT: LCD TV

Model No. : L26HD41

Test Date: Feb.12, 2009

Temperature: 24°C

Humidity: 47%

The details of test modes are as follows :

NO.	Test Mode	Resolution & Frequency	Reference Test Data No.	
			Horizontal	Vertical
1.	Running "H" Pattern and Playing Music	640*480 60Hz	#6	#5
2.		800*600 60Hz	#4	#3
3. ※		<b>1024*768 60Hz</b>	<b>#2</b>	<b>#1</b>

(※ Worst test mode)

##### **For frequency range 1GHz~2GHz**

The EUT with below test mode 1~3 was measured within Anechoic Chamber and the test results listed in next pages.

All the PK emissions were comply with average limit, So the average level were deemed to comply with average limit

Test Date: Feb.12, 2009

Temperature: 23°C

Humidity: 54%

NO.	Test Mode	Resolution & Frequency	Reference Test Data No.	
			Horizontal	Vertical
1.	Running "H" Pattern and Playing Music	640*480 60Hz	#8	#7
2.		800*600 60Hz	#9	#10
3.		1024*768 60Hz	#12	#11



No.6, Ke Feng Road, Block 52,  
 Shenzhen Science & Industry Park  
 Nantou Shenzhen, Guangdong, China  
 Tel: +86-755-26639495  
 Fax: +86-755-26632877  
 Postcode: 518057

Data: 6 File: D:\2009 Report Data\TCL\ACS8Q2012.EM6 (30)

Date: 2009-02-12

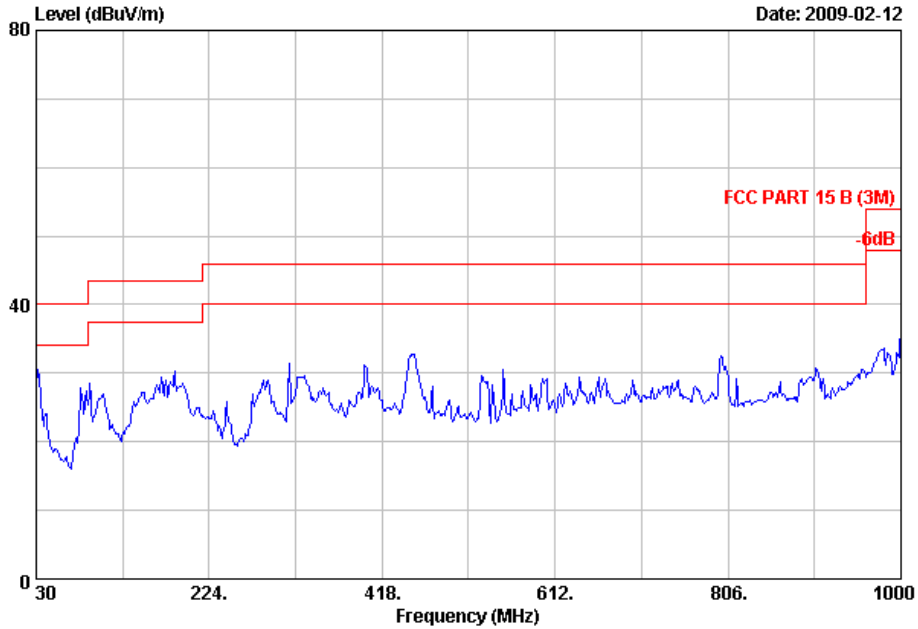

Site no. : 3m Chamber Data no. : 6  
 Dis. / Ant. : 3m CBL6111C Ant. pol. : HORIZONTAL  
 Limit : FCC PART 15 B (3M)  
 Env. / Ins. : 24°C/47% Engineer : Victory  
 EUT : LCD TV M/N:L26HD41  
 Power Rating : AC 120V/60Hz  
 Test Mode : Running 'H' Pattern And Playing Music  
 640\*480@60Hz

Data: 5 File: D:\2009 Report Data\TCL\ACS8Q2012.EM6 (30)

Date: 2009-02-12

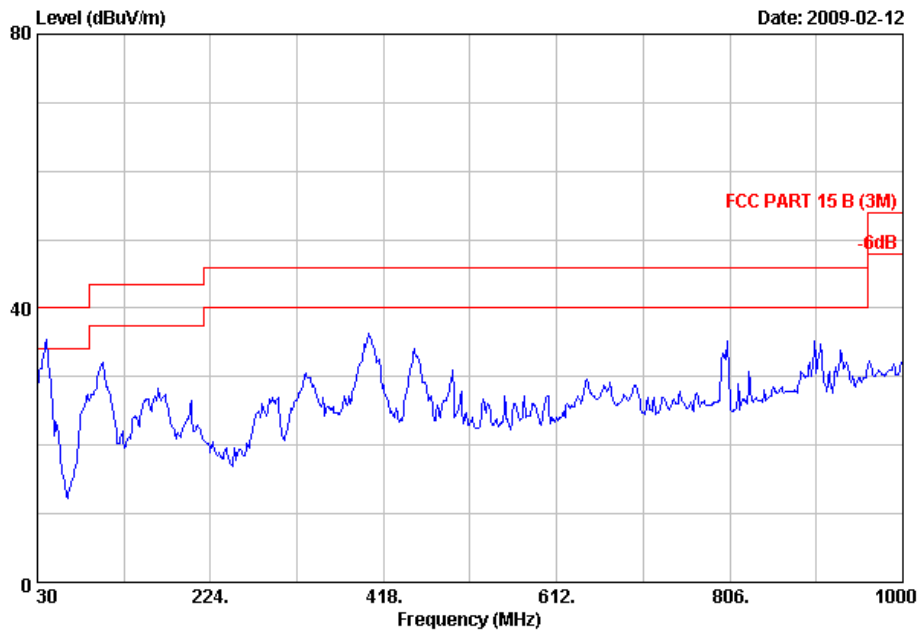

Site no. : 3m Chamber Data no. : 5  
 Dis. / Ant. : 3m CBL6111C Ant. pol. : VERTICAL  
 Limit : FCC PART 15 B (3M)  
 Env. / Ins. : 24°C/47% Engineer : Victory  
 EUT : LCD TV M/N:L26HD41  
 Power Rating : AC 120V/60Hz  
 Test Mode : Running 'H' Pattern And Playing Music  
 640\*480@60Hz



No.6,Ke Feng Road,Block 52,  
Shenzhen Science&Industry Park  
Nantou Shenzhen,Guangdong, China  
Tel:+86-755-26639495  
Fax:+86-755-26632877  
Postcode:518057

Data: 4 File: D:\2009 Report Data\TCL\ACS8Q2012.EM6 (30)

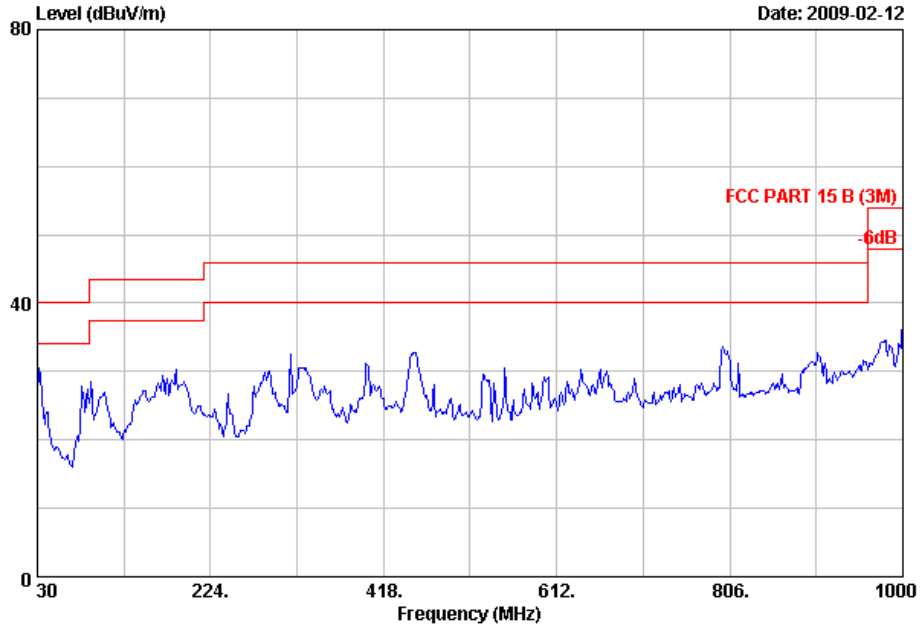

Site no. : 3m Chamber Data no. : 4  
Dis. / Ant. : 3m CBL6111C Ant. pol. : HORIZONTAL  
Limit : FCC PART 15 B (3M)  
Env. / Ins. : 24\*C/47% Engineer : Victory  
EUT : LCD TV M/N:L26HD41  
Power Rating : AC 120V/60Hz  
Test Mode : Running 'H' Pattern And Playing Music  
800\*600@60Hz

Data: 3 File: D:\2009 Report Data\TCL\ACS8Q2012.EM6 (30)

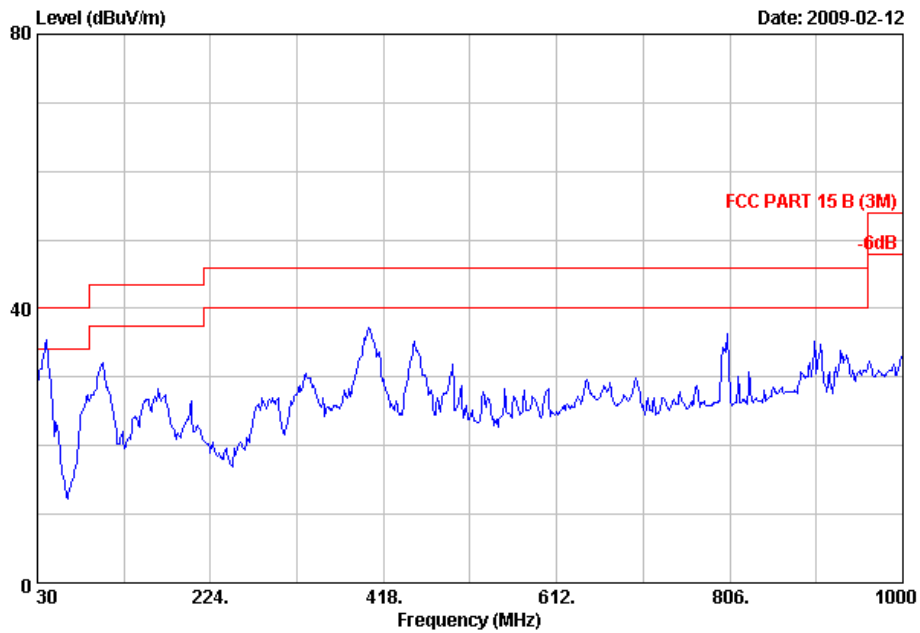

Site no. : 3m Chamber Data no. : 3  
Dis. / Ant. : 3m CBL6111C Ant. pol. : VERTICAL  
Limit : FCC PART 15 B (3M)  
Env. / Ins. : 24\*C/47% Engineer : Victory  
EUT : LCD TV M/N:L26HD41  
Power Rating : AC 120V/60Hz  
Test Mode : Running 'H' Pattern And Playing Music  
800\*600@60Hz



No.6,Ke Feng Road,Block 52,  
Shenzhen Science&Industry Park  
Nantou Shenzhen,Guangdong,China  
Tel:+86-755-26639495  
Fax:+86-755-26632877  
Postcode:518057

Data: 2 File: D:\2009 Report Data\TCL\ACS8Q2012.EM6 (30)

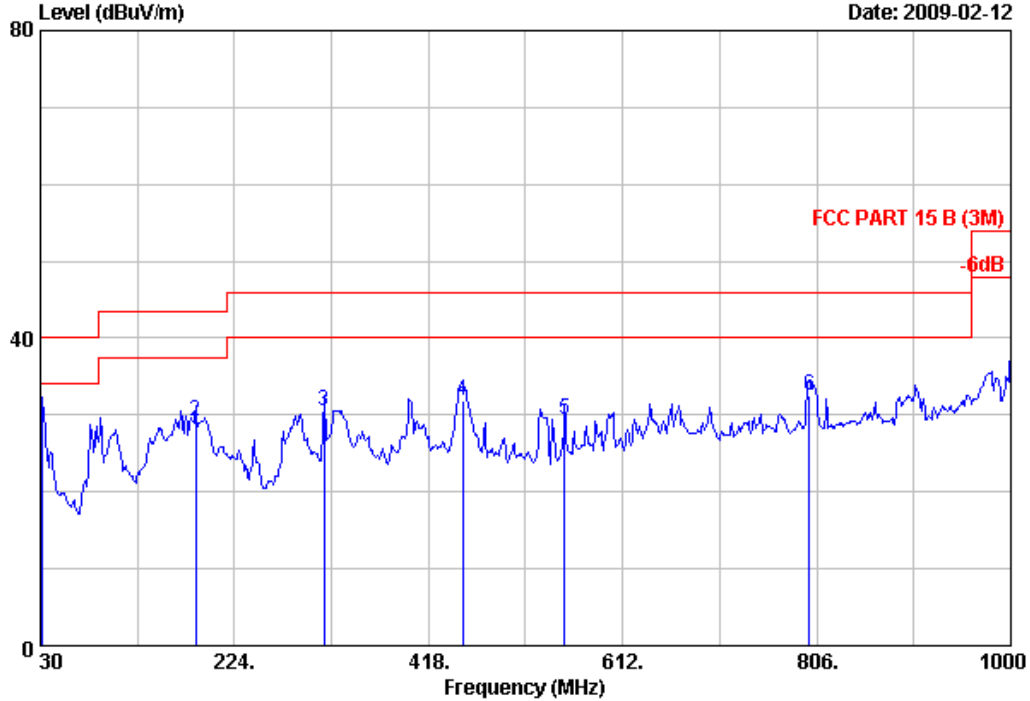

Site no. : 3m Chamber Data no. : 2  
 Dis. / Ant. : 3m CBL6111C Ant. pol. : HORIZONTAL  
 Limit : FCC PART 15 B (3M)  
 Env. / Ins. : 24°C/47% Engineer : Victory  
 EUT : LCD TV M/N:L26HD41  
 Power Rating : AC 120V/60Hz  
 Test Mode : Running 'H' Pattern And Playing Music  
 1024\*768@60Hz

	Freq. (MHz)	Ant. Factor (dB/m)	Cable Loss (dB)	Reading (dBuV)	Emission Level (dBuV/m)	Limits (dBuV/m)	Margin (dB)	Remark
1	31.940	18.73	0.49	10.41	29.63	40.00	10.37	QP
2	185.200	9.34	1.32	18.58	29.24	43.50	14.26	QP
3	313.240	13.80	1.88	14.77	30.45	46.00	15.55	QP
4	451.950	17.11	2.36	12.33	31.80	46.00	14.20	QP
5	553.800	18.92	2.72	7.81	29.45	46.00	16.55	QP
6	798.240	21.72	3.52	7.36	32.60	46.00	13.40	QP

- Remarks: 1. Emission Level= Antenna Factor + Cable Loss + Reading.  
 2. The emission levels that are 20dB below the official limit are not reported.  
 3. The worst emission was detected at 31.94MHz with corrected signal level of 29.63dBμV/m (Limit is 40.00dBμV/m) when the antenna was at horizontal polarization and at 2.0m high and the turn table was at 145°.  
 4. 0° was the table front facing the antenna. Degree is calculated from 0° clockwise facing the antenna.



No.6,Ke Feng Road,Block 52,  
Shenzhen Science&Industry Park  
Nantou Shenzhen,Guangdong,China  
Tel:+86-755-26639495  
Fax:+86-755-26632877  
Postcode:518057

Data: 1 File: D:\2009 Report Data\T\TCL\ACS8Q2012.EM6 (30)

Date: 2009-02-12

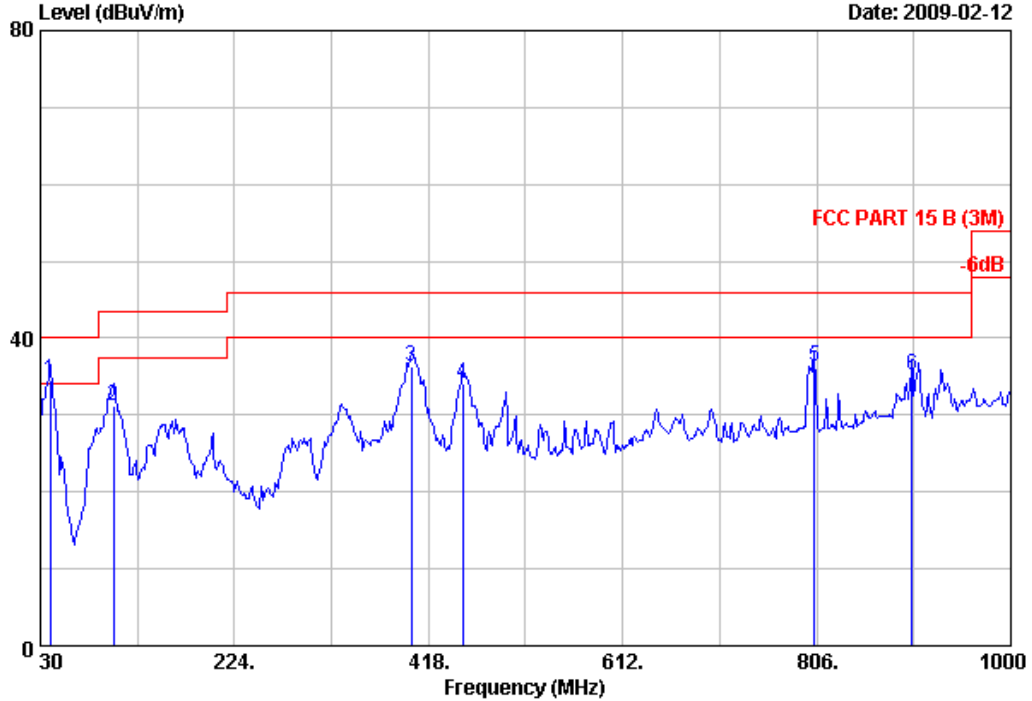

Site no. : 3m Chamber Data no. : 1  
 Dis. / Ant. : 3m CBL6111C Ant. pol. : VERTICAL  
 Limit : FCC PART 15 B (3M)  
 Env. / Ins. : 24°C/47% Engineer : Victory  
 EUT : LCD TV M/N:L26HD41  
 Power Rating : AC 120V/60Hz  
 Test Mode : Running 'H' Pattern And Playing Music  
 1024\*768@60Hz

	Freq. (MHz)	Ant. Factor (dB/m)	Cable Loss (dB)	Reading (dBuV)	Emission Level (dBuV/m)	Limits (dBuV/m)	Margin (dB)	Remark
1	39.700	14.41	0.54	19.50	34.45	40.00	5.55	QP
2	102.750	10.55	0.94	19.68	31.17	43.50	12.33	QP
3	400.540	16.23	2.20	17.81	36.24	46.00	9.76	QP
4	451.950	17.11	2.36	14.65	34.12	46.00	11.88	QP
5	804.060	21.78	3.54	10.97	36.29	46.00	9.71	QP
6	901.060	22.65	3.84	8.81	35.30	46.00	10.70	QP

- Remarks:
1. Emission Level= Antenna Factor + Cable Loss + Reading.
  2. The emission levels that are 20dB below the official limit are not reported.
  3. The worst emission was detected at 39.70MHz with corrected signal level of 34.45dBuV/m (Limit is 40.00dBuV/m) when the antenna was at vertical polarization and at 1.0m high and the turn table was at 310°.
  4. 0° was the table front facing the antenna. Degree is calculated from 0° clockwise facing the antenna.



No.6 Ke Feng Road,Block 52,  
ShenZhen Science & Industry Park  
Noutou,ShenZhen,GuangDong,China  
Tel:+86-755-26639495-7  
Fax:+86-755-26632877  
Postcode:518057

Data: 8 File: E:\2009 report data\T\TCL\ACS8Q2012.EM6 (18)

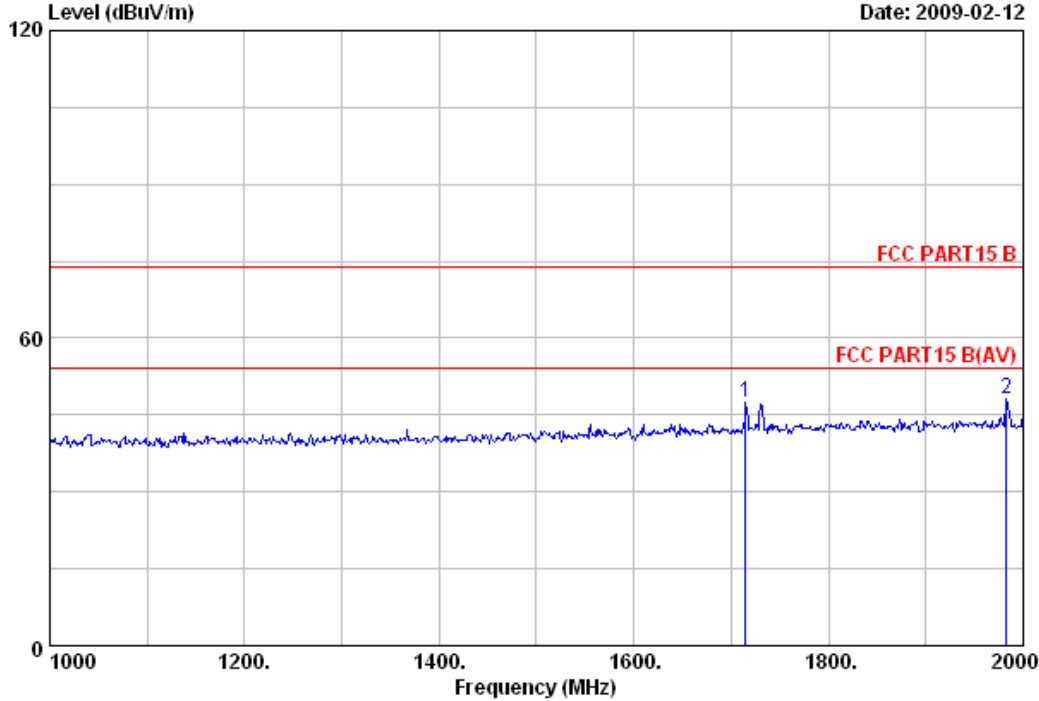

Site no. : 10# Chamber Data no. : 8  
 Dis. / Ant. : 3m 3115 Ant. pol. : HORIZONTAL  
 Limit : FCC PART15 B  
 Env. / Ins. : 23\*C/54% Engineer : Victory  
 EUT : LCD TV M/N: L26HD41  
 Power Rating : AC 120V/60Hz  
 Test mode : 1024\*768@60Hz  
 Running"H"Pattern And Playing Music

	Freq. (MHz)	Ant. Factor (dB/m)	Cable Loss (dB)	Amp Factor (dB)	Reading (dBuV)	Emission Level (dBuV/m)	Limits (dBuV/m)	Margin (dB)	Remark
1	1715.000	26.77	5.67	35.51	50.54	47.47	74.00	26.53	Peak
2	1983.000	27.83	6.16	35.20	49.33	48.12	74.00	25.88	Peak

Remarks:

1. Emission Level= Antenna Factor + Cable Loss -Amp Factor + Reading.
2. The emission levels that are 20dB below the official limit are not reported.





No.6 Ke Feng Road,Block 52,  
ShenZhen Science & Industry Park  
Noutou,ShenZhen,GuangDong,China  
Tel:+86-755-26639495-7  
Fax:+86-755-26632877  
Postcode:518057

Data: 7 File: E:\2009 report data\T\TCL\ACS8Q2012.EM6 (18)

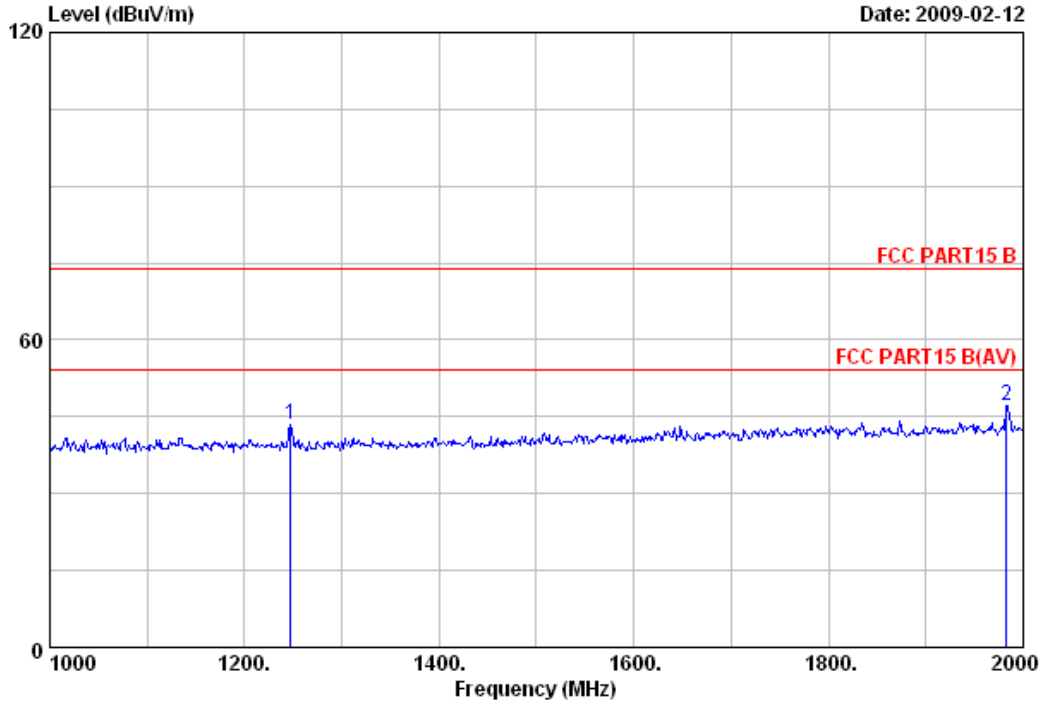

Site no. : 10# Chamber Data no. : 7  
 Dis. / Ant. : 3m 3115 Ant. pol. : VERTICAL  
 Limit : FCC PART15 B  
 Env. / Ins. : 23\*C/54% Engineer : Victory  
 EUT : LCD TV M/N:L26HD41  
 Power Rating : AC 120V/60Hz  
 Test mode : 1024\*768@60Hz  
 Running"H"Pattern And Playing Music

	Freq. (MHz)	Ant. Factor (dB/m)	Cable Loss (dB)	Amp Factor (dB)	Reading (dBuV)	Emission Level (dBuV/m)	Limits (dBuV/m)	Margin (dB)	Remark
1	1247.000	25.56	4.85	36.02	48.90	43.29	74.00	30.71	Peak
2	1983.000	27.83	6.16	35.20	48.38	47.17	74.00	26.83	Peak

Remarks:

1. Emission Level= Antenna Factor + Cable Loss -Amp Factor + Reading.
2. The emission levels that are 20dB below the official limit are not reported.



No.6 Ke Feng Road,Block 52,  
ShenZhen Science & Industry Park  
Noutou,ShenZhen,GuangDong,China  
Tel:+86-755-26639495-7  
Fax:+86-755-26632877  
Postcode:518057

Data: 9 File: E:\2009 report data\T\TCL\ACS8Q2012.EM6 (18)

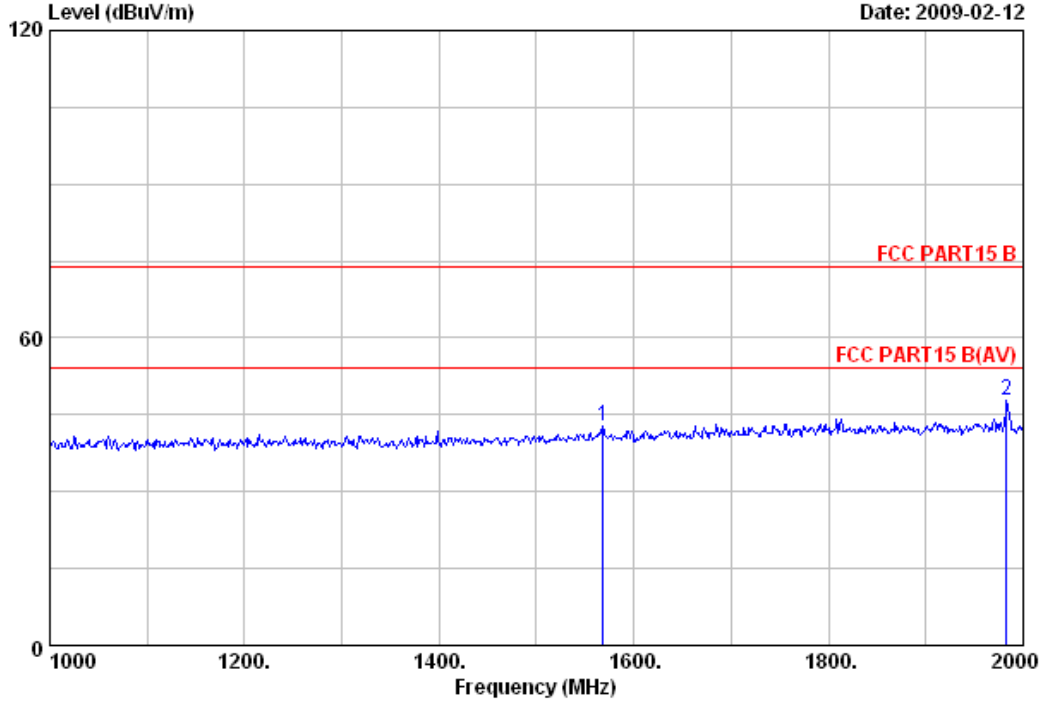

Site no. : 10# Chamber Data no. : 9  
 Dis. / Ant. : 3m 3115 Ant. pol. : HORIZONTAL  
 Limit : FCC PART15 B  
 Env. / Ins. : 23\*C/54% Engineer : Victory  
 EUT : LCD TV M/N:L26HD41  
 Power Rating : AC 120V/60Hz  
 Test mode : 800\*600@60Hz  
 Running"H"Pattern And Playing Music

	Freq. (MHz)	Ant. Factor (dB/m)	Cable Loss (dB)	Amp Factor (dB)	Reading (dBuV)	Emission Level (dBuV/m)	Limits (dBuV/m)	Margin (dB)	Remark
1	1568.000	26.17	5.40	35.68	46.97	42.86	74.00	31.14	Peak
2	1983.000	27.83	6.16	35.20	48.92	47.71	74.00	26.29	Peak

Remarks:

1. Emission Level= Antenna Factor + Cable Loss -Amp Factor + Reading.
2. The emission levels that are 20dB below the official limit are not reported.



No.6 Ke Feng Road,Block 52,  
ShenZhen Science & Industry Park  
Noutou,ShenZhen,GuangDong,China  
Tel:+86-755-26639495-7  
Fax:+86-755-26632877  
Postcode:518057

Data: 10 File: E:\2009 report data\T\TCL\ACS8Q2012.EM6 (18)

Date: 2009-02-12

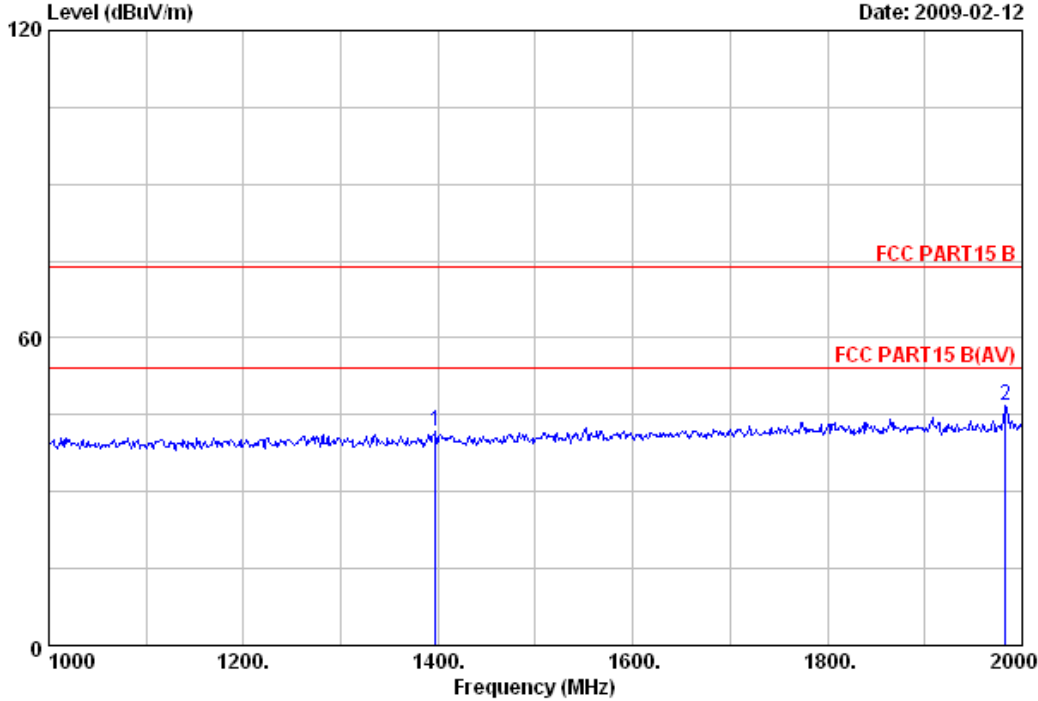

Site no. : 10# Chamber Data no. : 10  
 Dis. / Ant. : 3m 3115 Ant. pol. : VERTICAL  
 Limit : FCC PART15 B  
 Env. / Ins. : 23\*C/54% Engineer : Victory  
 EUT : LCD TV M/N:L26HD41  
 Power Rating : AC 120V/60Hz  
 Test mode : 800\*600@60Hz  
 Running"H"Pattern And Playing Music

	Freq. (MHz)	Ant. Factor (dB/m)	Cable Loss (dB)	Amp Factor (dB)	Reading (dBuV)	Emission Level (dBuV/m)	Limits (dBuV/m)	Margin (dB)	Remark
1	1397.000	25.76	5.08	35.85	46.92	41.91	74.00	32.09	Peak
2	1983.000	27.83	6.16	35.20	47.95	46.74	74.00	27.26	Peak

Remarks:

1. Emission Level= Antenna Factor + Cable Loss -Amp Factor + Reading.
2. The emission levels that are 20dB below the official limit are not reported.



No.6 Ke Feng Road,Block 52,  
ShenZhen Science & Industry Park  
Noutou,ShenZhen,GuangDong,China  
Tel:+86-755-26639495-7  
Fax:+86-755-26632877  
Postcode:518057

Data: 12 File: E:\2009 report data\T\TCL\ACS8Q2012.EM6 (18)

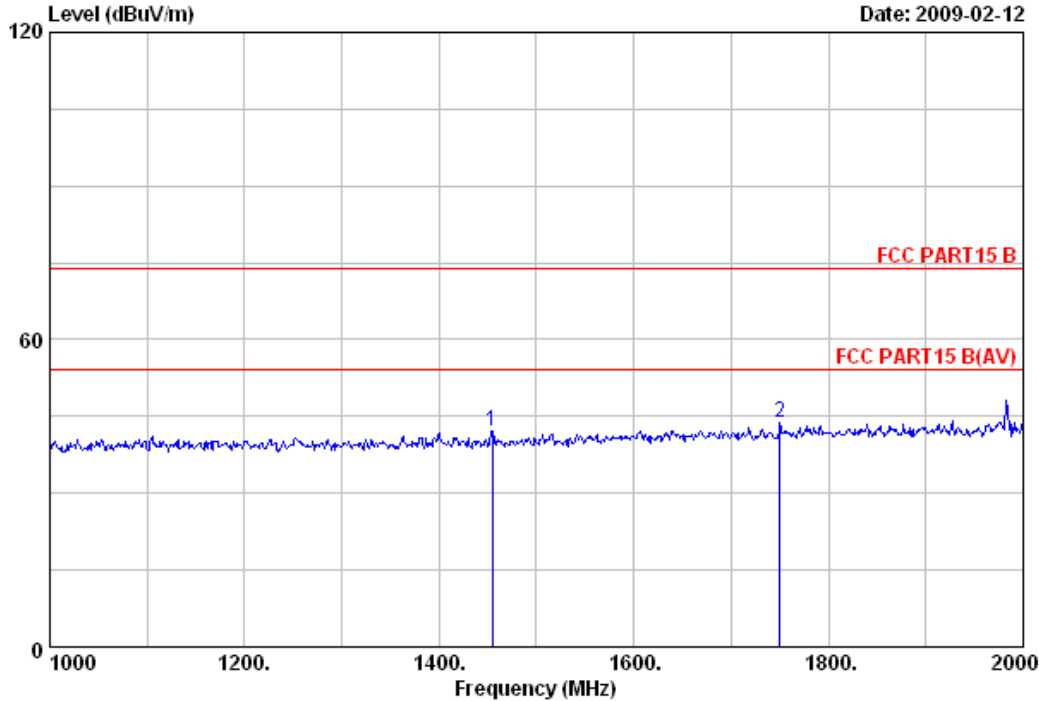

Site no. : 10# Chamber Data no. : 12  
 Dis. / Ant. : 3m 3115 Ant. pol. : HORIZONTAL  
 Limit : FCC PART15 B  
 Env. / Ins. : 23\*C/54% Engineer : Victory  
 EUT : LCD TV M/N:L26HD41  
 Power Rating : AC 120V/60Hz  
 Test mode : 640\*480@60Hz  
 Running"H"Pattern And Playing Music

	Freq. (MHz)	Ant. Factor (dB/m)	Cable Loss (dB)	Amp Factor (dB)	Reading (dBuV)	Emission Level (dBuV/m)	Limits (dBuV/m)	Margin (dB)	Remark
1	1455.000	25.85	5.21	35.79	46.81	42.08	74.00	31.92	Peak
2	1750.000	26.90	5.74	35.48	46.74	43.90	74.00	30.10	Peak

Remarks:

1. Emission Level= Antenna Factor + Cable Loss -Amp Factor + Reading.
2. The emission levels that are 20dB below the official limit are not reported.



No.6 Ke Feng Road,Block 52,  
ShenZhen Science & Industry Park  
Noutou,ShenZhen,GuangDong,China  
Tel:+86-755-26639495-7  
Fax:+86-755-26632877  
Postcode:518057

Data: 11 File: E:\2009 report data\T\TCL\ACS8Q2012.EM6 (18)

Date: 2009-02-12

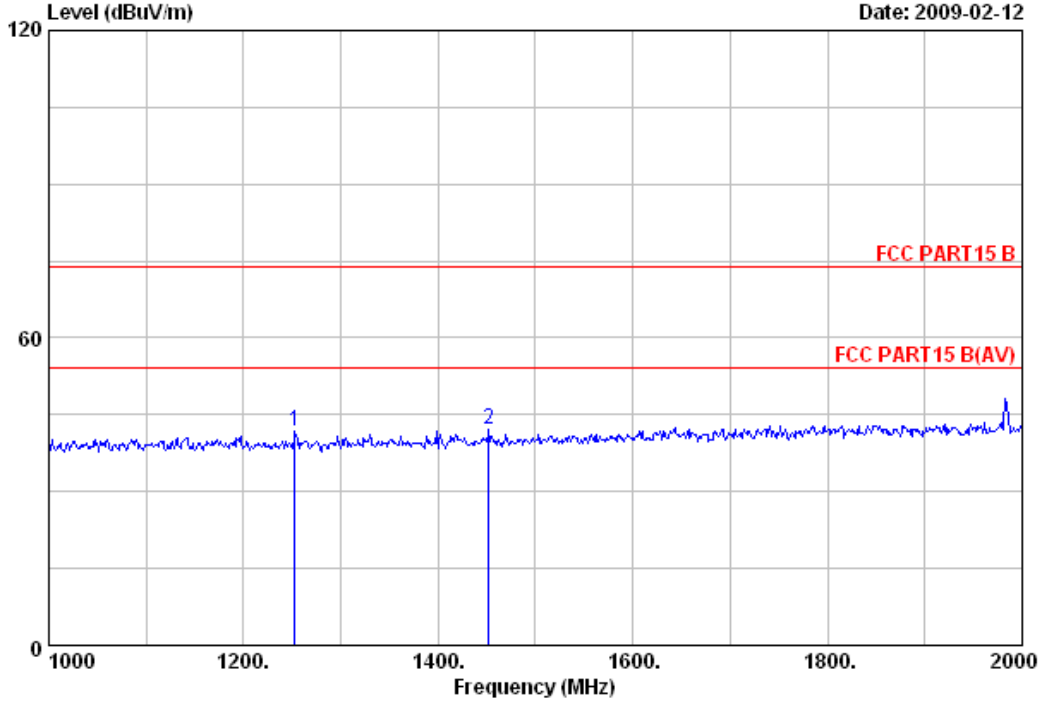

Site no. : 10# Chamber Data no. : 11  
 Dis. / Ant. : 3m 3115 Ant. pol. : VERTICAL  
 Limit : FCC PART15 B  
 Env. / Ins. : 23\*C/54% Engineer : Victory  
 EUT : LCD TV M/N:L26HD41  
 Power Rating : AC 120V/60Hz  
 Test mode : 640\*480@60Hz  
 Running"H"Pattern And Playing Music

	Freq. (MHz)	Ant. Factor (dB/m)	Cable Loss (dB)	Amp Factor (dB)	Reading (dBUV)	Emission Level (dBUV/m)	Limits (dBUV/m)	Margin (dB)	Remark
1	1253.000	25.56	4.85	36.02	47.34	41.73	74.00	32.27	Peak
2	1452.000	25.85	5.21	35.79	46.95	42.22	74.00	31.78	Peak

Remarks:

1. Emission Level= Antenna Factor + Cable Loss -Amp Factor + Reading.
2. The emission levels that are 20dB below the official limit are not reported.

## **5. DEVIATION TO TEST SPECIFICATIONS**

[ NONE ]

## 6. PHOTOGRAPH

### 6.1.Photos of Power Line Conducted Emission Test





## 6.2.Photos of Radiated Emission Test (In Anechoic Chamber)





## 7. PHOTOS OF THE EUT

**Figure 1**  
General Appearance of the EUT



**Figure 2**  
General Appearance of the EUT



**Figure 3**  
General Appearance of the EUT



**Figure 4**  
General Appearance of the EUT



**Figure 5**  
General Appearance of the EUT



**Figure 6**  
General Appearance of the EUT



**Figure 7**  
Inside of the EUT



**Figure 8**  
Inside of the EUT





**Figure 9**  
Speaker of the EUT



**Figure 10**  
Inside of the EUT



**Figure 11**  
Inside of the EUT



**Figure 12**  
Label of the EUT

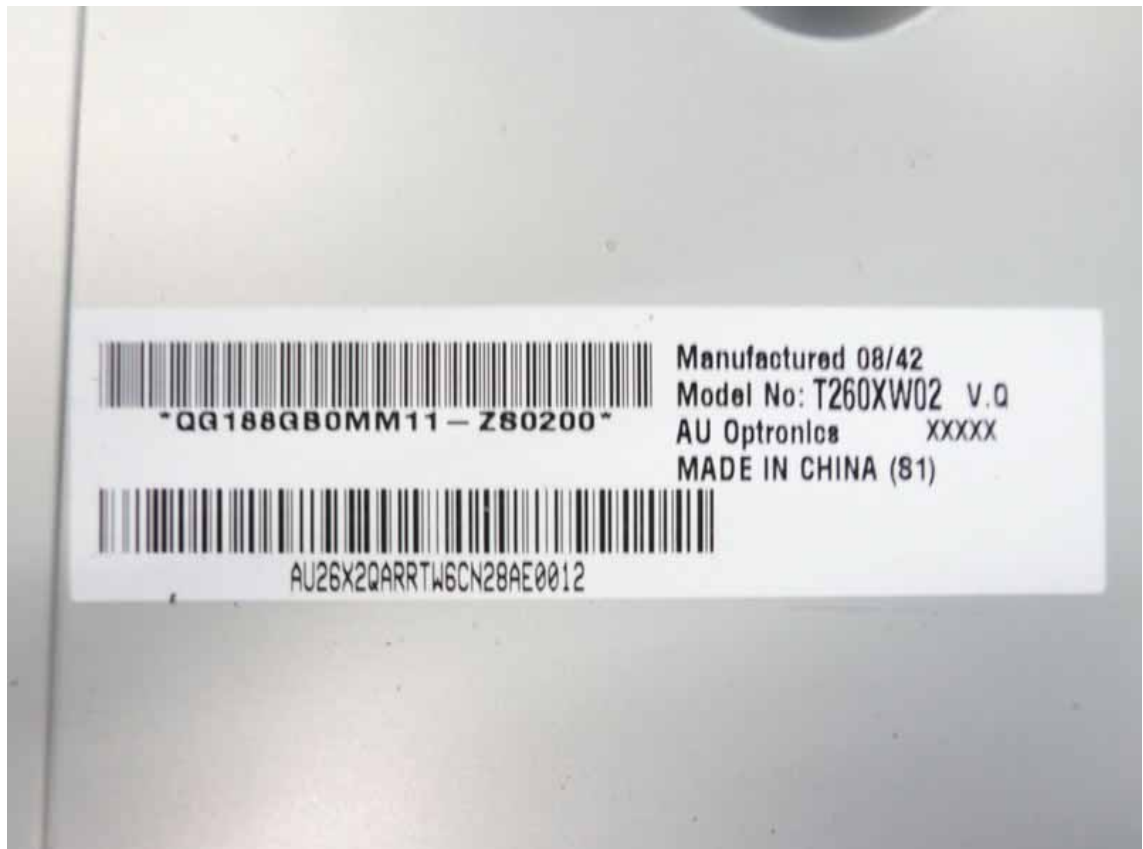

**Figure 13**  
Component Side of the PCB



**Figure 14**  
Component Side of the PCB

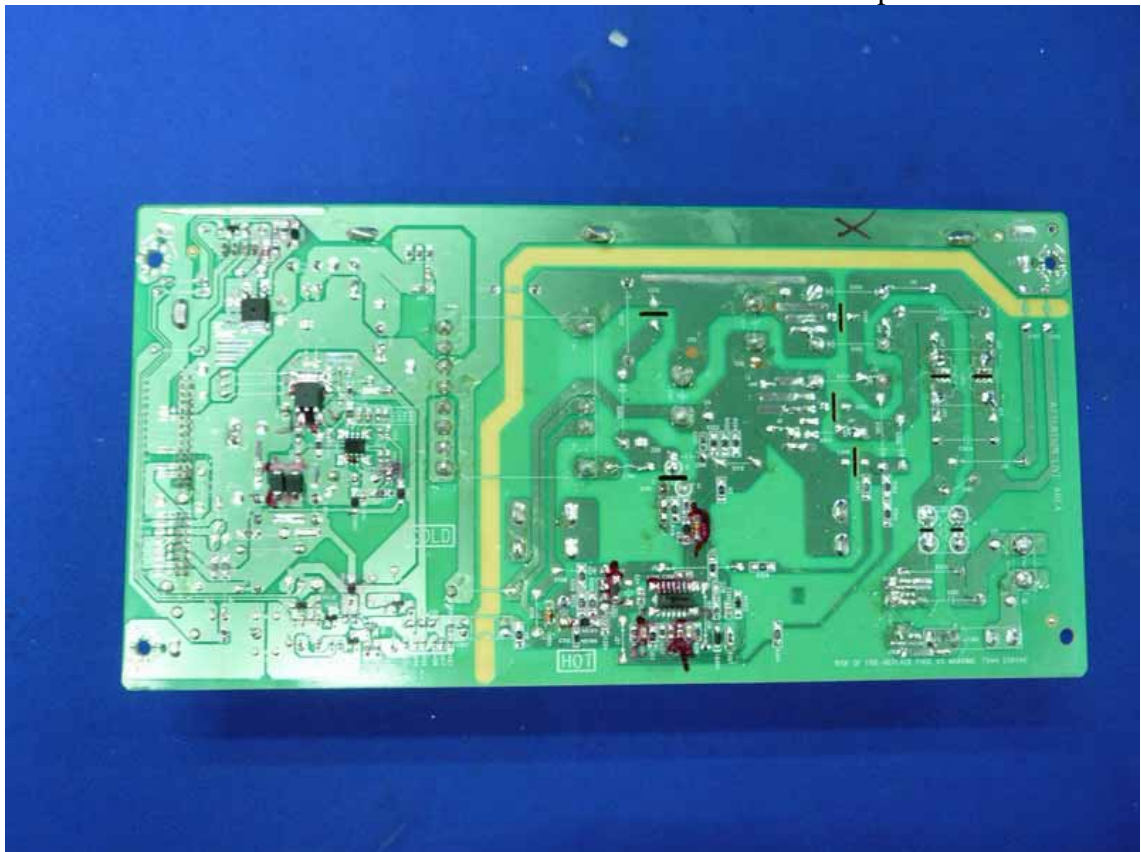



**Figure 15**  
Component Side of the PCB

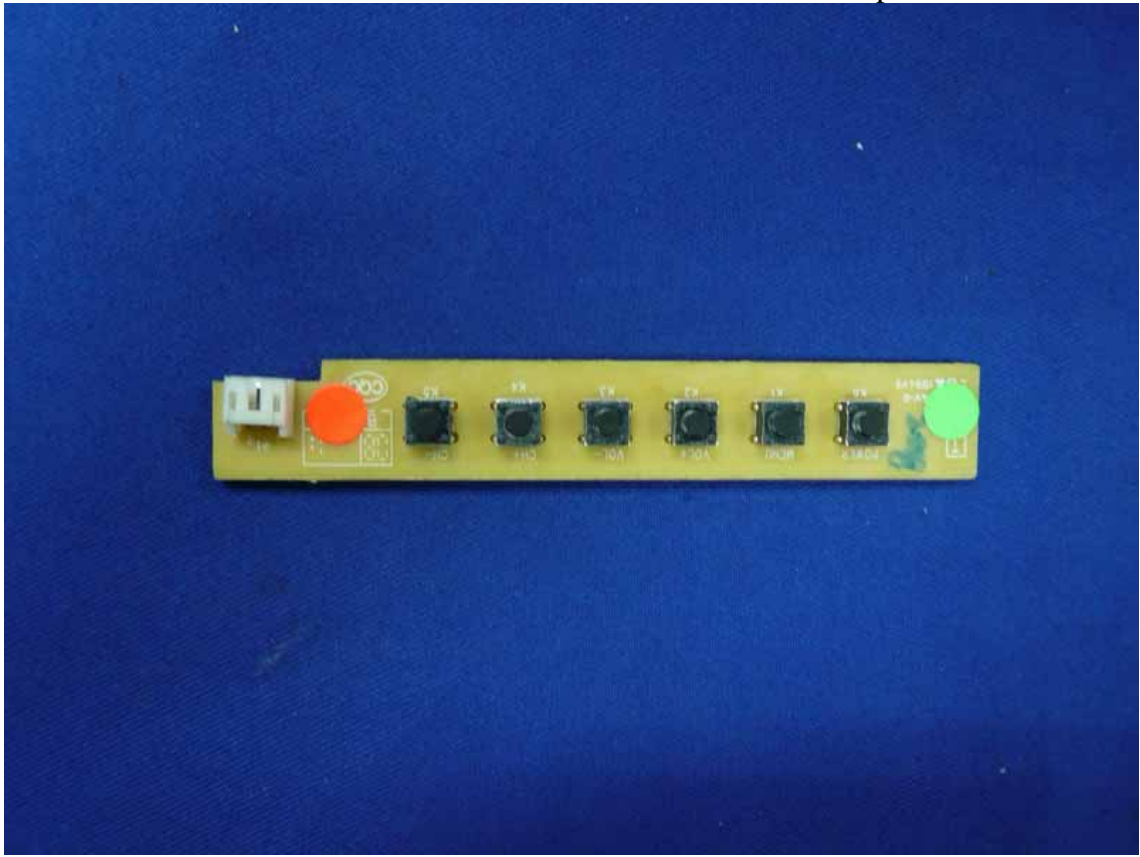

**Figure 16**  
Component Side of the PCB

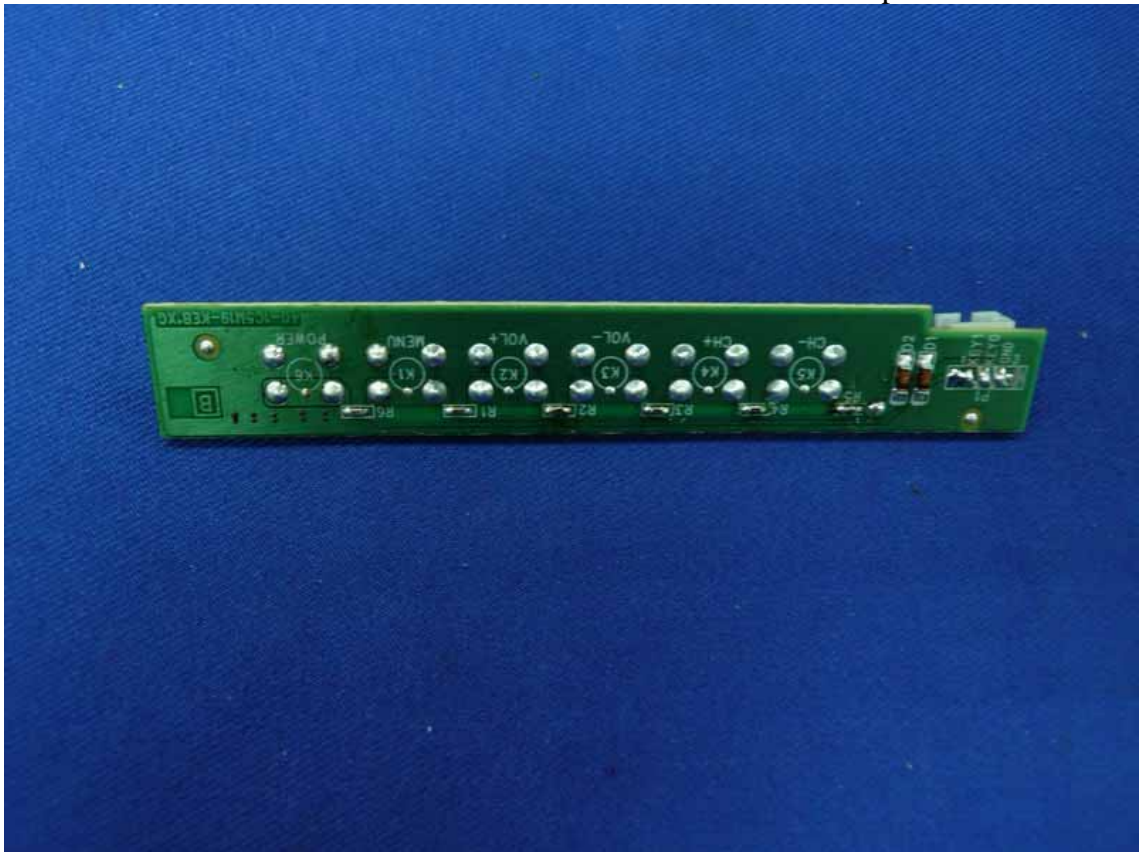



**Figure 17**  
Component Side of the PCB



**Figure 18**  
Component side of the PCB



**Figure 19**  
Component side of the PCB

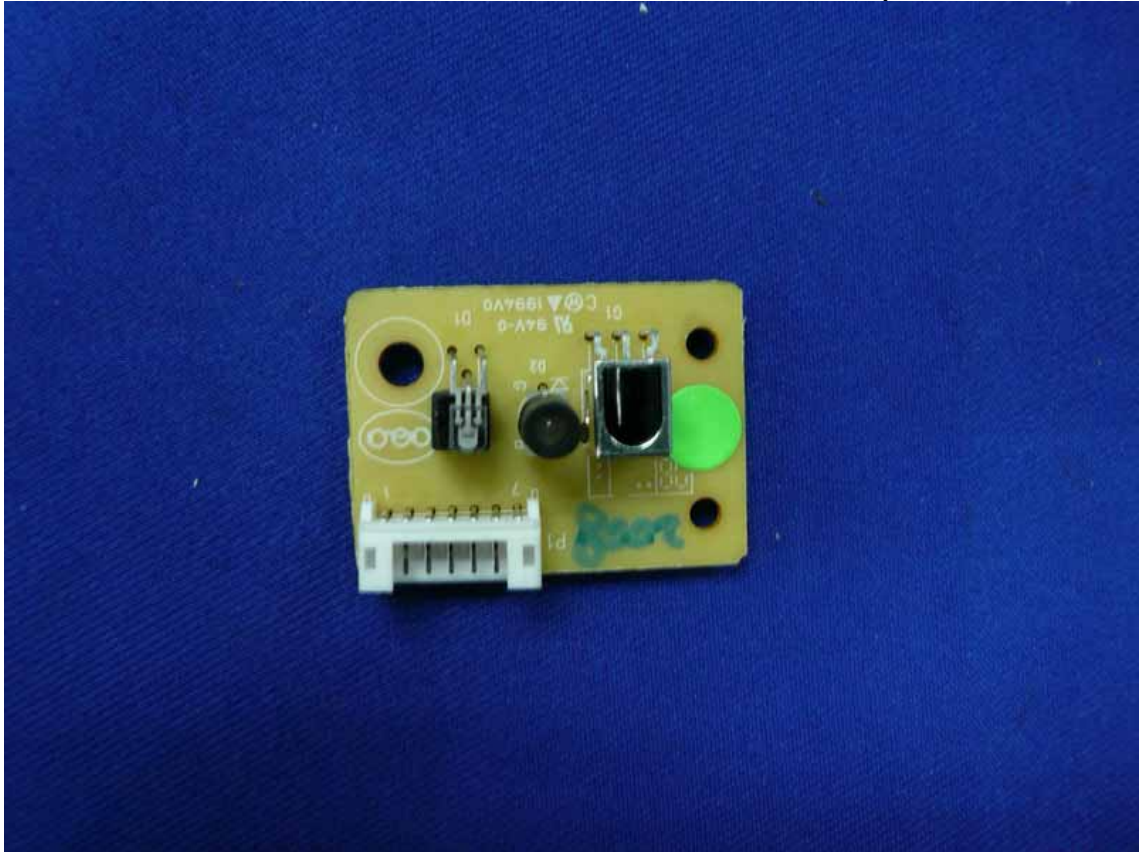

**Figure 20**  
Component side of the PCB

