



FCC ID:W8U50FS5600

APPLICATION OF CERTIFICATION

For

TTE Technology Inc.

LCD TV

Brand Name	Model Number
TCL	50FS5600

FCC ID: W8U50FS5600

Prepared for : TTE Technology Inc.
555 S. Promenade Ave., Suite 103, Corona, CA 92879,
U.S.A.

Prepared By: Audix Technology (Shenzhen) Co., Ltd.
No. 6, Ke Feng Rd., 52 Block,
Shenzhen Science & Industrial Park,
Nantou, Shenzhen, Guangdong, China

Tel: (0755) 26639496
Fax: (0755) 26632877

Report Number : ACS- F13360
Date of Test : Dec.12~14, 2013
Date of Report : Dec.26, 2013

TABLE OF CONTENTS

Description	Page
Test Report Certification	
1. SUMMARY OF STANDARDS AND RESULTS	1-1
1.1. Description of Standards and Results	1-1
2. GENERAL INFORMATION.....	2-1
2.1. Description of Device (EUT).....	2-1
2.2. Tested Supporting System Details	2-2
2.3. Block diagram of connection between the EUT and simulators.....	2-3
2.4. Test Facility	2-4
2.5. Measurement Uncertainty (95% confidence levels, k=2).....	2-4
3. POWER LINE CONDUCTED EMISSION MEASUREMENT.....	3-1
3.1. Test Equipment.....	3-1
3.2. Block Diagram of Test Setup.....	3-1
3.3. Power Line Conducted Emission Test Limits	3-1
3.4. Configuration of EUT on Test.....	3-1
3.5. Operating Condition of EUT	3-2
3.6. Test Procedure	3-2
3.7. Conducted Emission at Mains Terminals Test Results.....	3-2
4. RADIATED EMISSION MEASUREMENT.....	4-1
4.1. Test Equipment.....	4-1
4.2. Block Diagram of Test Setup.....	4-2
4.3. Radiated Emission Limit	4-3
4.4. EUT Configuration on Test	4-3
4.5. Operating Condition of EUT	4-3
4.6. Test Procedure	4-3
4.7. Radiated Emission Test Results.....	4-4
5. DEVIATION TO TEST SPECIFICATIONS	5-1
6. PHOTOGRAPH	6-1
6.1. Photos of Power Line Conducted Emission Test.....	6-1
6.2. Photos of Radiated Emission Test (In Anechoic Chamber)	6-2
7. PHOTOS OF THE EUT	7-1

TEST REPORT CERTIFICATION

Applicant : TTE Technology Inc.
 Manufacturer : TCL King Electrical Appliances (Huizhou) Co., Ltd.
 EUT Description : LCD TV
 FCC ID : W8U50FS5600

(A) Model No. & Brand Name	Brand Name	Model Number
	TCL	50FS5600

(B) Power Supply : AC 120V/60Hz
 (C) Test Voltage : AC 120V/60Hz

Measurement Standard Used:

FCC Rules and Regulations Part 15 Subpart B Class B 2012

The device described above is tested by AUDIX TECHNOLOGY (SHENZHEN) CO., LTD. to determine the maximum emission levels emanating from the device. The maximum emission levels are compared to the FCC Part 15 Subpart B Class B limits both conducted and radiated emissions. The test results are contained in this test report, and AUDIX TECHNOLOGY (SHENZHEN) CO., LTD. is assumed of full responsibility for the accuracy and completeness of these tests. This report contains data that are not covered by the NVLAP accreditation.

After the test, our opinion is that EUT compliance with the requirement of the above standards.

This Report is made under FCC Part 2.1075. No modifications were required during testing to bring this product into compliance.

This report applies to above tested sample only. This report shall not be reproduced in parts without written approval of AUDIX TECHNOLOGY (SHENZHEN) CO., LTD.

The report must not be used by the client to claim product certification, approval, or endorsement by NVLAP, NIST, or any agency of the federal government.

Date of Test : Dec.12~ 14, 2013 Report of date: Dec.26, 2013

Prepared by : Julia Zhu Reviewed by : Sun Zeng
 Julia Zhu / Assistant Sun Zeng / Assistant Manager

信華科技 (深圳) 有限公司
 Audix Technology (Shenzhen) Co., Ltd.
 EMC 部門報告專用章

Stamp only for EMC Dept. Report

Signature: David Jin 12-26

Approved & Authorized Signer : _____
 David Jin / Manager

1. SUMMARY OF STANDARDS AND RESULTS

1.1. Description of Standards and Results

The EUT have been tested according to the applicable standards as referenced below.

EMISSION			
Description of Test Item	Standard	Results	Remarks
Power Line Conducted Emission Test	FCC Part 15: 2012 ANSI C63.4: 2009	PASS	Meets Class B Limit Minimum passing margin is 11.17dB at 0.17215MHz
Radiated Emission Test (30-1000MHz)	FCC Part 15: 2012 ANSI C63.4: 2009	PASS	Meets Class B Limit Minimum passing margin is 3.61dB at 43.600MHz
Radiated Emission Test (1-5GHz)	FCC Part 15: 2012 ANSI C63.4: 2009	PASS	Meets Class B Limit Minimum passing margin is 14.37dB at 1183.450MHz

2. GENERAL INFORMATION

2.1. Description of Device (EUT)

Description : LCD TV

Model Number & Brand Name :	Brand Name	Model Number
	TCL	50FS5600

FCC ID : W8U50FS5600

Applicant : TTE Technology Inc.
555 S. Promenade Ave., Suite 103, Corona, CA 92879,
U.S.A.

Manufacturer : TCL King Electrical Appliances (Huizhou) Co., Ltd.
Section 19, Zhongkai Development Zone for New and High Level
TECH Industries, Huizhou, Guangdong 516006, P.R. China.

FREQUENCIES USED AND GENERATED WITHIN DEVICE	
LVDS (HD)	78MHZ
LVDS (FHD)	75MHZ
IF	6MHz
DC-DC	U302->385KHz
DDR	390 MHz

Internal photos of the EUT shows AC sockets line, FCC WIRE line, debug with the countermeasure scheme, these countermeasures and EUT production together.

Date of Test : Dec.12~14, 2013

Date of Receipt : Dec.11, 2013

Sample Type : Prototype production

2.2. Tested Supporting System Details

	Description	ACS No.	Manufacturer	Model	Serial Number	Approved type
1.	Personal Computer	Test PC S	DELL	Vostro 470	2SP05W1	<input checked="" type="checkbox"/> FCC DoC <input checked="" type="checkbox"/> BSMI ID:R33002 Power Cord: Unshielded, Detachable, 1.8m Display Card: HD3450 (DVI+VGA+HDMI)
2.	USB Keyboard	ACS-EMC- K04R	DELL	SK-8115	CN-ODJ313-71616-6 BB-049J	<input checked="" type="checkbox"/> FCC DoC <input checked="" type="checkbox"/> BSMI ID: T3A002 Data Cable: shielded, Undetachable, 2.0m
3.	Headphone	ACS-EMC-EP03	OVANN	OV880V	N/A	<input type="checkbox"/> FCC ID <input type="checkbox"/> BSMI ID Cable: Shielded, Undetachabled, 4.0m
4.	Printer	ACS-EMC-PT04	HP	C9079A	N/A	<input checked="" type="checkbox"/> FCC DoC <input checked="" type="checkbox"/> BSMI ID: R33001 USB Cable: Shielded, Detachabled, 1.8m Power Cord: Unshielded, Detachabled, 1.8m Power Adapter: HP, M/N: 0957-2119, BSMI ID: R33030, DC Cable: Unshielded, Detachabled, 1.5m
5.	USB Mouse	ACS-EMC-M04R	DELL	M056UO	512024282	<input checked="" type="checkbox"/> FCC DoC <input checked="" type="checkbox"/> BSMI ID: R41108 Data Cable: shielded, Undetachable, 1.8m
6.	3.0 HDD	ACS-EMC-HDD13	Buffalo	HD-HX1.0T U3-AP	45564800401175	<input checked="" type="checkbox"/> FCC DoC <input checked="" type="checkbox"/> BSMI ID: D33093 USB Cable: Unshielded, Detachable, 1.0m
7.	HDD	ACS-EMC-HDD02	Terasys	F12-UF	A0100215-5390018	<input checked="" type="checkbox"/> FCC DoC <input checked="" type="checkbox"/> BSMI ID: 4912A022 USB Cable: Shielded, Detachable, 1.8m
8.	Power Cable: Unshielded, Detachable, 1.8m HDMI Cable: Shielded, Detachable, 1.8m Component In Cable: Unshielded, Detachable, 1.8m SPDIF Cable: Unshielded, Detachable, 1.5m					

2.3. Block diagram of connection between the EUT and simulators

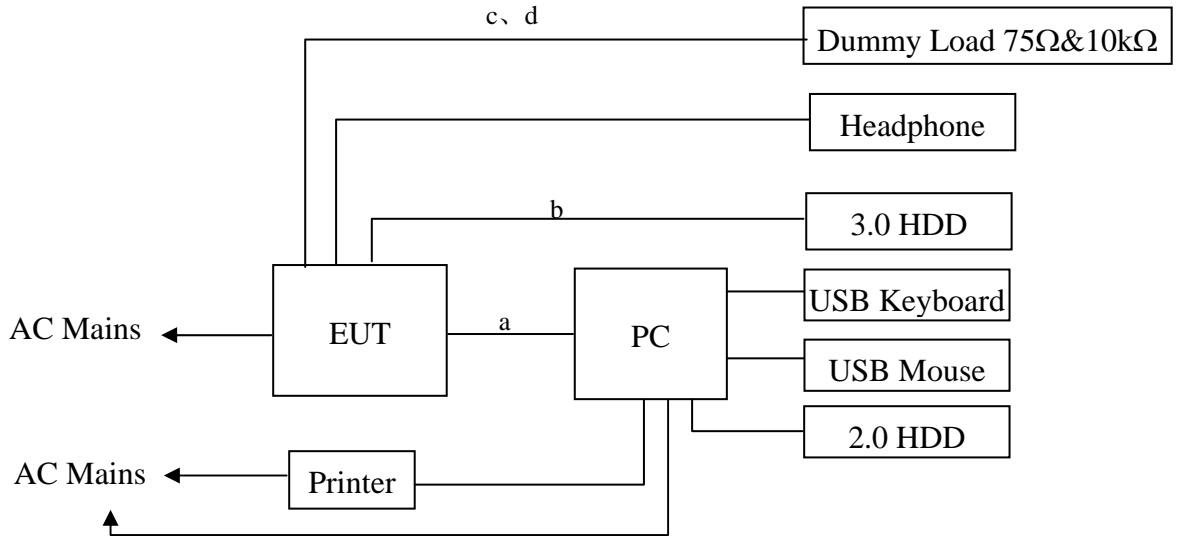

- a: HDMI*3 Cable
- b: USB Cable
- c: Component In Cable
- d: SPDIF Cable

(EUT: LCD TV)

2.4. Test Facility

Site Description

Name of Firm : Audix Technology (Shenzhen) Co., Ltd.
No. 6, Ke Feng Rd., 52 Block, Shenzhen
Science & Industrial Park, Nantou,
Shenzhen, Guangdong, China

3m Anechoic Chamber : Certificated by FCC, USA
Registration Number: 90454
Valid Date: Feb.22, 2015

3m & 10m Anechoic Chamber : Certificated by FCC, USA
Registration Number: 794232
Valid Date: Oct.31, 2015

EMC Lab. : Accredited by DAkkS, Germany
Registration No: D-PL-12151-01-01
Valid Date: Feb.01, 2014

: Accredited by NVLAP, USA
NVLAP Code: 200372-0
Valid Date: Mar.31, 2014

2.5. Measurement Uncertainty (95% confidence levels, k=2)

Test Item	Uncertainty
Uncertainty for Conduction emission test in No. 1 Conduction	3.1 dB(150KHz to 30MHz)
Uncertainty for Radiation Emission test in 3m chamber	3.22 dB(30~200MHz, Polarize: H)
	3.23 dB(30~200MHz, Polarize: V)
	3.49 dB(200M~1GHz, Polarize: H)
	3.39 dB(200M~1GHz, Polarize: V)
Uncertainty for Radiation Emission test in 3m chamber (1GHz-18GHz)	4.97 dB(1~6GHz, Distance: 3m)
	4.99 dB(6~18GHz, Distance: 3m)
Uncertainty for test site temperature and humidity	3%
	0.6°C

3. POWER LINE CONDUCTED EMISSION MEASUREMENT

3.1. Test Equipment

Item	Equipment	Manufacturer	Model No.	Serial No.	Last Cal.	Cal. Interval
1.	Test Receiver	Rohde & Schwarz	ESHS10	838693/001	Oct.31, 13	1 Year
2.	L.I.S.N.#1	Rohde & Schwarz	ESH2-Z5	834066/011	Oct.31, 13	1 Year
3.	L.I.S.N.#3	Kyoritsu	KNW-242C	8-1920-1	May.08, 13	1 Year
4.	Terminator	Hubersuhner	50Ω	No. 1	May.08, 13	1 Year
5.	Terminator	Hubersuhner	50Ω	No. 2	May.08, 13	1 Year
6.	RF Cable	Fujikura	3D-2W	No.1	May.08, 13	1 Year
7.	Coaxial Switch	Anritsu	MP59B	M50564	May.08, 13	1 Year
8.	Pulse Limiter	Rohde & Schwarz	ESH3-Z2	100341	May.08, 13	1 Year

3.2. Block Diagram of Test Setup

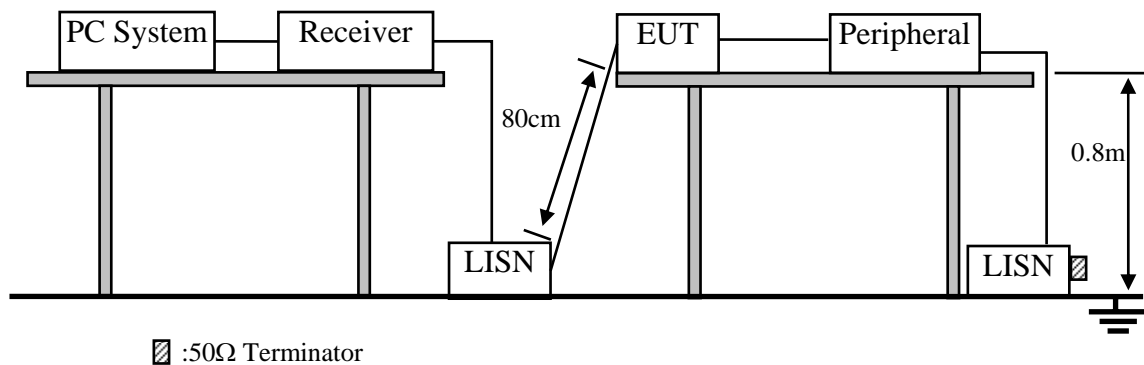

3.3. Power Line Conducted Emission Test Limits

Frequency	Maximum RF Line Voltage	
	Quasi-Peak Level dB(μV)	Average Level dB(μV)
150kHz ~ 500kHz	66 ~ 56*	56 ~ 46*
500kHz ~ 5MHz	56	46
5MHz ~ 30MHz	60	50

- Notes: 1. * Decreasing linearly with logarithm of frequency.
 2. The lower limit shall apply at the transition frequencies.

3.4. Configuration of EUT on Test

The following equipment are installed on Power Line Conducted Emission Test to meet the commission requirement and operating regulations in a manner which tends to maximize its emission characteristics in a normal application.

3.4.1. LCD TV (EUT)

Model Number : 50FS5600
 Serial Number : N/A

3.4.2. Support Equipment : As Tested Supporting System Detail, in Section 2.2.

3.5. Operating Condition of EUT

- 3.5.1. Setup the EUT and simulator as shown as Section 3.2.
- 3.5.2. Turn on the power of all equipment.
- 3.5.3. PC system ran the Self-test program “EMC Test. exe” by windows XP and sent “H” Character to LCD TV (EUT) , the Screen of EUT displayed and filled with “H” pattern, use white letters on a black ground, set the contrast control to maximum, set the brightness control to maximum and measure it.
- 3.5.4. The other peripheral devices were driven and operated in turn during all testing.

3.6. Test Procedure

The EUT was placed on a non-metallic table, 80cm above the ground plane. The EUT Power connected to the power mains through a line impedance stabilization network (L.I.S.N. 1#). This provided a 50-ohm coupling impedance for the EUT (Please refer to the block diagram of the test setup and photographs). The other peripheral devices power cord connected to the power mains through a line impedance stabilization network (L.I.S.N.# 3). Both sides of power line were checked for maximum conducted interference. In order to find the maximum emission, the relative positions of equipments and all of the interface cables were changed according to ANSI C63.4: 2009 on conducted Emission test.

The bandwidth of test receiver (R&S TEST RECEIVER ESHS10) is set at 9kHz.

The frequency range from 150kHz to 30MHz is checked. The test result are reported on Section 3.7.

3.7. Conducted Emission at Mains Terminals Test Results

PASS. (All emissions not reported below are too low against the prescribed limits.)

The EUT with the following test modes were tested and selected to read Q.P values and average values, all the test results are listed in next pages.

EUT: LCD TV Model No. : 50FS5600

Test Date: Dec.12, 2013 Temperature: 24.9°C Humidity: 44%

The details of test modes are as follows :

No.	Test Mode	Input Port	Resolution & Frequency	Reference Test Data No.	
				Line	Neutral
The Worst for Video Resolution of original report:					
1.✘	PC Mode	HDMI 1	1920*1080/60Hz	#30	#29
2.		HDMI 2	1920*1080/60Hz	#31	#32
3.		HDMI 3	1920*1080/60Hz	#33	#34

(✘ Worst test mode)

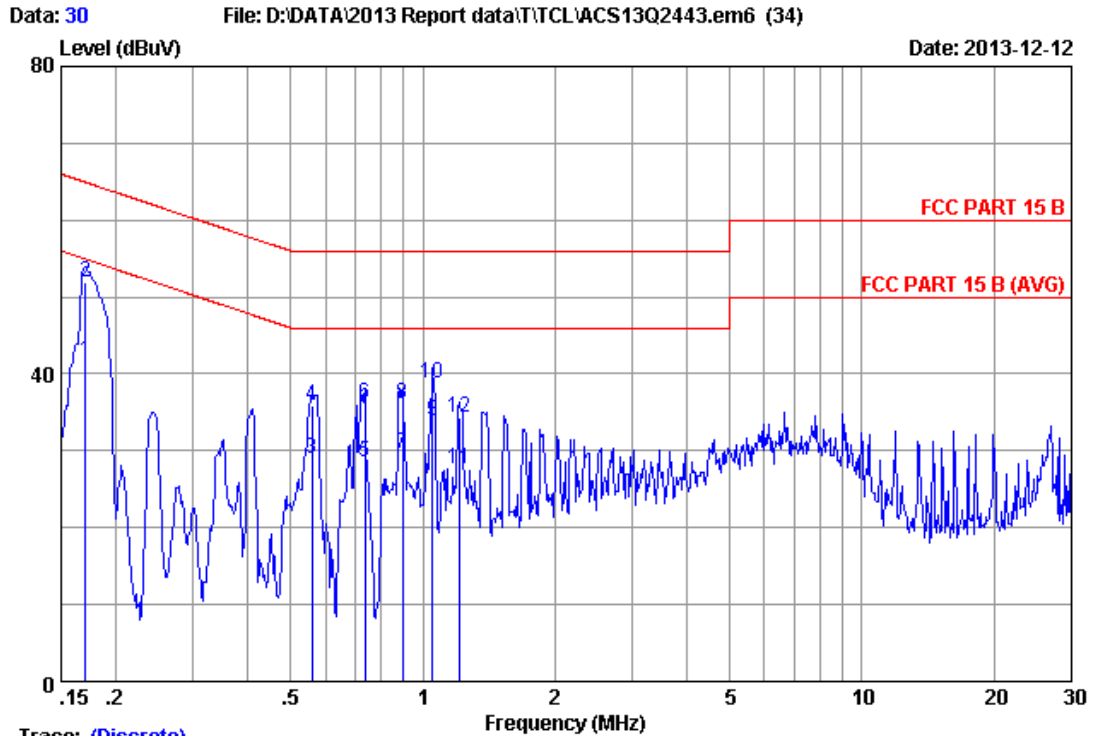

Trace: (Discrete)

Site no :1#conduction Data No :30

Dis./Ant. :2013 ESH2-25 LINE

Limit :FCC PART 15 B

Env./Ins. :24.9°C/44%

Engineer :Dota-YAO

EUT :LCD TV M/N:50FS5600

Power Rating :AC 120V/60Hz

Test Mode :Running "H" Pattern And 1KHz Playing

HDMI 1:1920*1080@60Hz

No	Freq (MHz)	LISN Factor (dB)	Cable Loss (dB)	Reading (dBuV)	Emission Level (dBuV)	Limits (dBuV)	Margin (dB)	Remark
1	0.17034	0.14	0.01	41.50	41.65	54.94	13.29	Average
2	0.17034	0.14	0.01	51.77	51.92	64.94	13.02	QP
3	0.55814	0.16	0.02	28.80	28.98	46.00	17.02	Average
4	0.55814	0.16	0.02	35.65	35.83	56.00	20.17	QP
5	0.73910	0.17	0.03	28.40	28.60	46.00	17.40	Average
6	0.73910	0.17	0.03	35.79	35.99	56.00	20.01	QP
7	0.89917	0.18	0.03	29.40	29.61	46.00	16.39	Average
8	0.89917	0.18	0.03	35.83	36.04	56.00	19.96	QP
9	1.054	0.18	0.03	33.60	33.81	46.00	12.19	Average
10	1.054	0.18	0.03	38.49	38.70	56.00	17.30	QP
11	1.210	0.19	0.03	27.40	27.62	46.00	18.38	Average
12	1.210	0.19	0.03	34.04	34.26	56.00	21.74	QP

Remarks: 1.Emission Level=LISN Factor+Cable Loss+Reading.
 2.If the average limit is met when using a quasi-peak detector, the EUT shall be deemed to meet both limits and measurement with average detector is unnecessary.

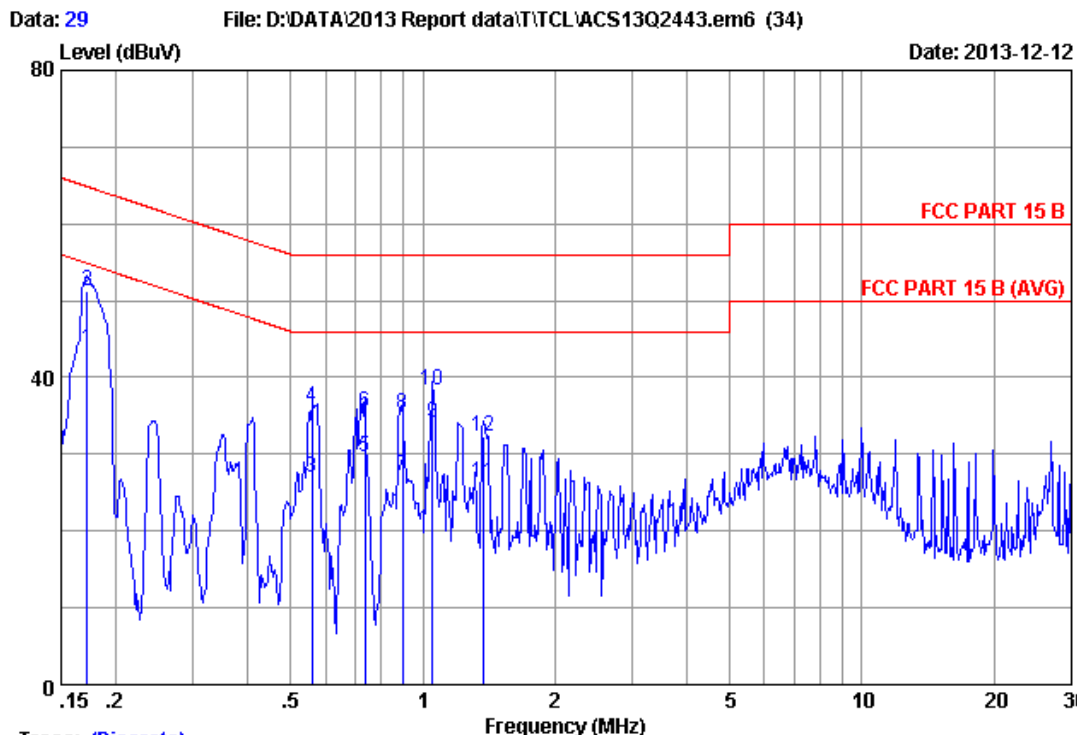

Trace: (Discrete)

Site no :1#conduction Data No :29
 Dis./Ant. :2013 ESH2-Z5 NEUTRAL
 Limit :FCC PART 15 B
 Env./Ins. :24.9°C/44% Engineer :Dota-YAO
 EUT :LCD TV M/N:50FS5600
 Power Rating :AC 120V/60Hz
 Test Mode :Running "H" Pattern And 1KHz Playing
 HDMI 1:1920*1080@60Hz

No	Freq (MHz)	LISN Factor (dB)	Cable Loss (dB)	Reading (dBUV)	Emission Level (dBUV)	Limits (dBUV)	Margin (dB)	Remark
1	0.17215	0.18	0.01	43.50	43.69	54.86	11.17	Average
2	0.17215	0.18	0.01	51.07	51.26	64.86	13.60	QP
3	0.55814	0.24	0.02	26.80	27.06	46.00	18.94	Average
4	0.55814	0.24	0.02	35.83	36.09	56.00	19.91	QP
5	0.73910	0.27	0.03	29.40	29.70	46.00	16.30	Average
6	0.73910	0.27	0.03	35.03	35.33	56.00	20.67	QP
7	0.89917	0.26	0.03	26.80	27.09	46.00	18.91	Average
8	0.89917	0.26	0.03	34.89	35.18	56.00	20.82	QP
9	1.054	0.26	0.03	33.70	33.99	46.00	12.01	Average
10	1.054	0.26	0.03	38.05	38.34	56.00	17.66	QP
11	1.374	0.26	0.03	26.10	26.39	46.00	19.61	Average
12	1.374	0.26	0.03	32.05	32.34	56.00	23.66	QP

Remarks: 1.Emission Level=LISN Factor+Cable Loss+Reading.
 2.If the average limit is met when using a quasi-peak detector, the EUT shall be deemed to meet both limits and measurement with average detector is unnecessary.

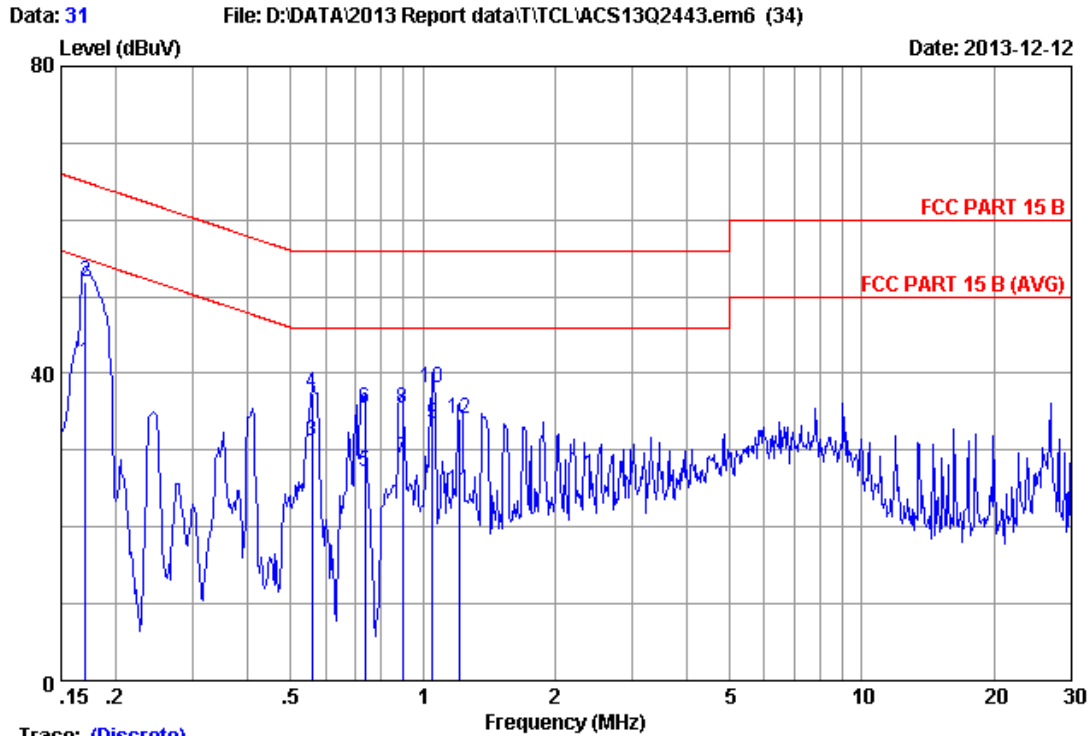

Trace: (Discrete)

Site no :1#conduction Data No :31
 Dis./Ant. :2013 ESH2-25 LINE
 Limit :FCC PART 15 B
 Env./Ins. :24.9°C/44% Engineer :Dota-YAO
 EUT :LCD TV M/N:50FS5600
 Power Rating :AC 120V/60Hz
 Test Mode :Running "H" Pattern And 1KHz Playing
 HDMI 2:1920*1080@60Hz

No	Freq (MHz)	LISN Factor (dB)	Cable Loss (dB)	Reading (dBuV)	Emission Level (dBuV)	Limits (dBuV)	Margin (dB)	Remark
1	0.17034	0.14	0.01	41.30	41.45	54.94	13.49	Average
2	0.17034	0.14	0.01	51.75	51.90	64.94	13.04	QP
3	0.55814	0.16	0.02	31.10	31.28	46.00	14.72	Average
4	0.55814	0.16	0.02	37.23	37.41	56.00	18.59	QP
5	0.73910	0.17	0.03	26.90	27.10	46.00	18.90	Average
6	0.73910	0.17	0.03	35.31	35.51	56.00	20.49	QP
7	0.89917	0.18	0.03	28.80	29.01	46.00	16.99	Average
8	0.89917	0.18	0.03	35.17	35.38	56.00	20.62	QP
9	1.054	0.18	0.03	33.20	33.41	46.00	12.59	Average
10	1.054	0.18	0.03	37.99	38.20	56.00	17.80	QP
11	1.210	0.19	0.03	24.60	24.82	46.00	21.18	Average
12	1.210	0.19	0.03	33.84	34.06	56.00	21.94	QP

Remarks: 1.Emission Level=LISN Factor+Cable Loss+Reading.
 2.If the average limit is met when using a quasi-peak detector, the EUT shall be deemed to meet both limits and measurement with average detector is unnecessary.

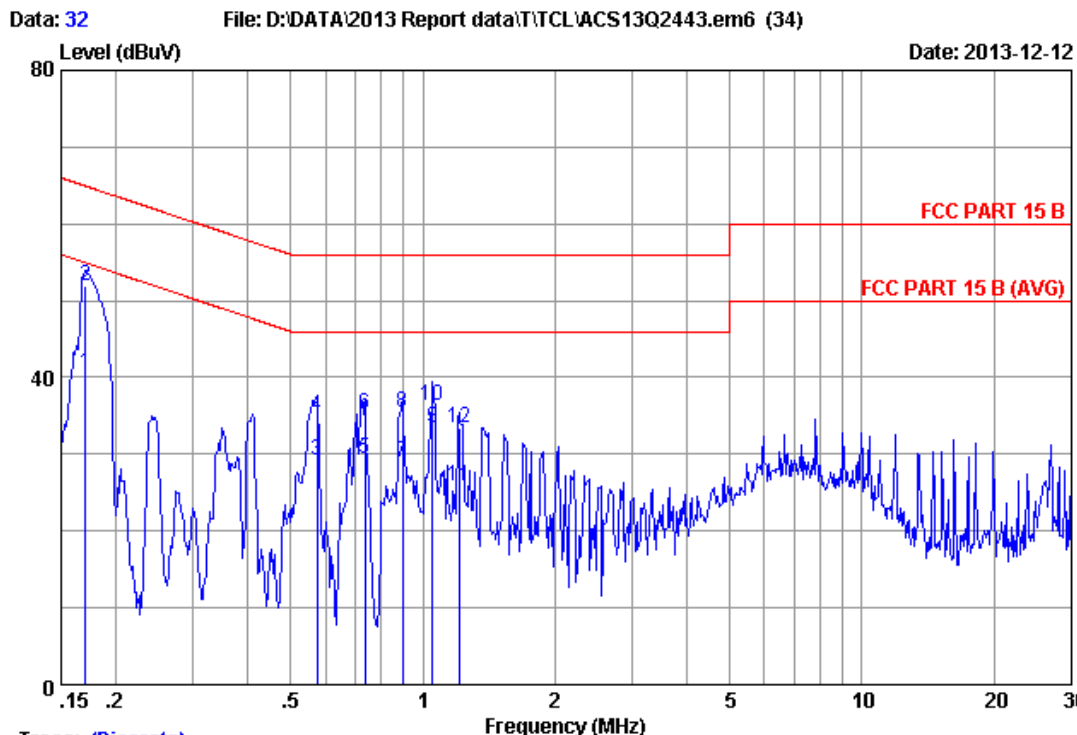

Trace: (Discrete)

Site no :1#conduction Data No :32
 Dis./Ant. :2013 ESH2-Z5 NEUTRAL
 Limit :FCC PART 15 B
 Env./Ins. :24.9°C/44% Engineer :Dota-YAO
 EUT :LCD TV M/N:50FS5600
 Power Rating :AC 120V/60Hz
 Test Mode :Running "H" Pattern And 1KHz Playing
 HDMI 2:1920*1080@60Hz

No	Freq (MHz)	LISN Factor (dB)	Cable Loss (dB)	Reading (dBuV)	Emission Level (dBuV)	Limits (dBuV)	Margin (dB)	Remark
1	0.17034	0.18	0.01	40.30	40.49	54.94	14.45	Average
2	0.17034	0.18	0.01	51.71	51.90	64.94	13.04	QP
3	0.57313	0.24	0.02	28.91	29.17	46.00	16.83	Average
4	0.57313	0.24	0.02	34.72	34.98	56.00	21.02	QP
5	0.73910	0.27	0.03	29.10	29.40	46.00	16.60	Average
6	0.73910	0.27	0.03	34.93	35.23	56.00	20.77	QP
7	0.89917	0.26	0.03	28.60	28.89	46.00	17.11	Average
8	0.89917	0.26	0.03	35.11	35.40	56.00	20.60	QP
9	1.054	0.26	0.03	33.10	33.39	46.00	12.61	Average
10	1.054	0.26	0.03	36.13	36.42	56.00	19.58	QP
11	1.210	0.26	0.03	25.50	25.79	46.00	20.21	Average
12	1.210	0.26	0.03	33.20	33.49	56.00	22.51	QP

Remarks: 1.Emission Level=LISN Factor+Cable Loss+Reading.
 2.If the average limit is met when using a quasi-peak detector, the EUT shall be deemed to meet both limits and measurement with average detector is unnecessary.

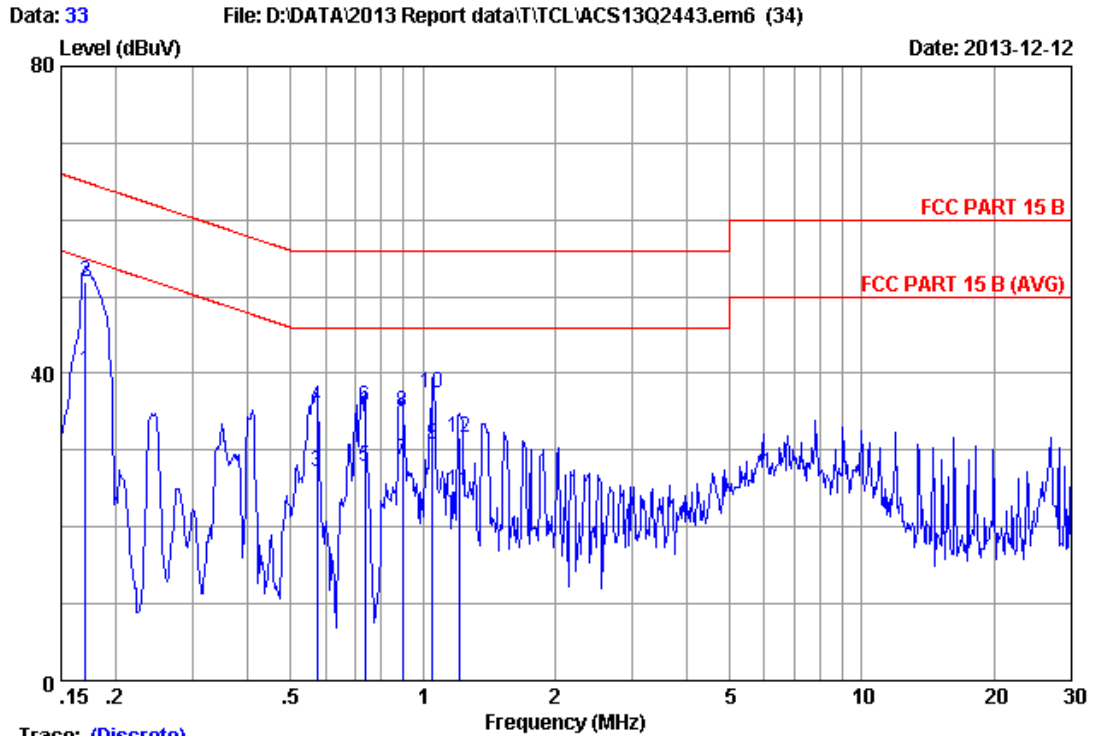

Site no :1#conduction Data No :33
 Dis./Ant. :2013 ESH2-Z5 LINE
 Limit :FCC PART 15 B
 Env./Ins. :24.9°C/44% Engineer :Dota-YAO
 EUT :LCD TV M/N:50FS5600
 Power Rating :AC 120V/60Hz
 Test Mode :Running "H" Pattern And 1KHz Playing
 HDMI 3:1920*1080@60Hz

No	Freq (MHz)	LISN Factor (dB)	Cable Loss (dB)	Reading (dBuV)	Emission Level (dBuV)	Limits (dBuV)	Margin (dB)	Remark
1	0.17034	0.18	0.01	40.20	40.39	54.94	14.55	Average
2	0.17034	0.18	0.01	51.73	51.92	64.94	13.02	QP
3	0.57313	0.16	0.02	27.11	27.29	46.00	18.71	Average
4	0.57313	0.24	0.02	35.42	35.68	56.00	20.32	QP
5	0.73910	0.17	0.03	27.60	27.80	46.00	18.20	Average
6	0.73910	0.27	0.03	35.31	35.61	56.00	20.39	QP
7	0.89917	0.18	0.03	28.50	28.71	46.00	17.29	Average
8	0.89917	0.26	0.03	34.71	35.00	56.00	21.00	QP
9	1.054	0.18	0.03	30.50	30.71	46.00	15.29	Average
10	1.054	0.26	0.03	37.05	37.34	56.00	18.66	QP
11	1.216	0.19	0.03	24.50	24.72	46.00	21.28	Average
12	1.216	0.26	0.03	31.36	31.65	56.00	24.35	QP

Remarks: 1.Emission Level=LISN Factor+Cable Loss+Reading.
 2.If the average limit is met when using a quasi-peak detector, the EUT shall be deemed to meet both limits and measurement with average detector is unnecessary.

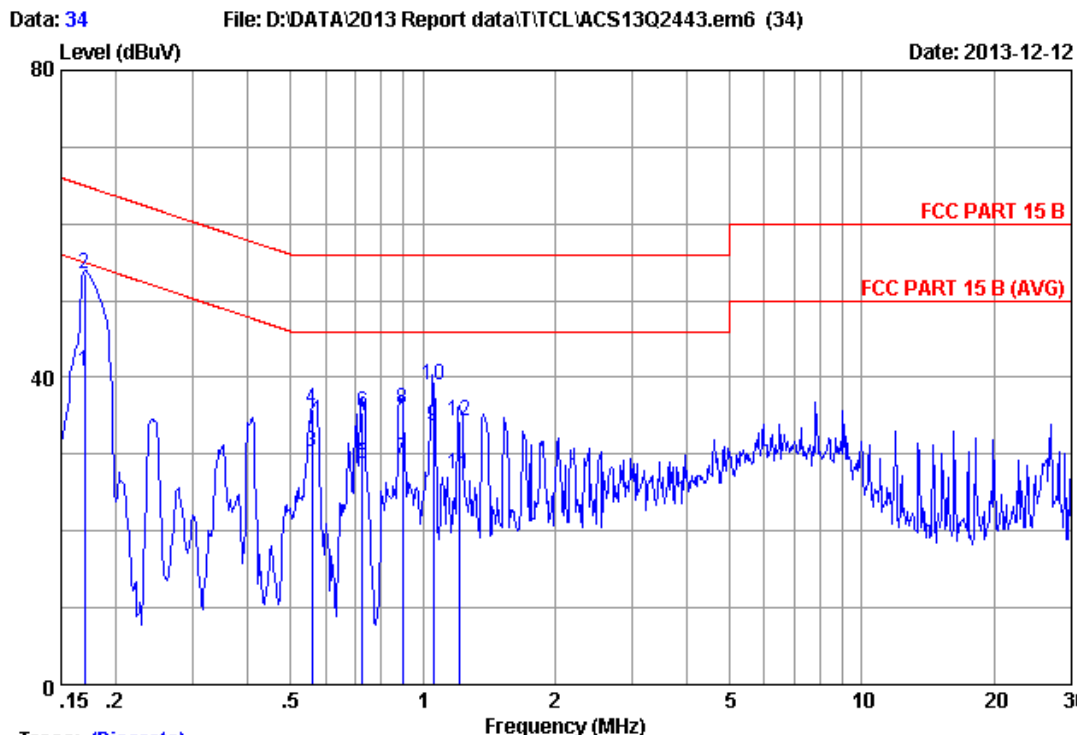

Trace: (Discrete)

Site no :1#conduction Data No :34
 Dis./Ant. :2013 ESH2-Z5 NEUTRAL
 Limit :FCC PART 15 B
 Env./Ins. :24.9*C/44% Engineer :Dota-YAO
 EUT :LCD TV M/N:50FS5600
 Power Rating :AC 120V/60Hz
 Test Mode :Running "H" Pattern And 1KHz Playing
 HDMI 3:1920*1080@60Hz

No	Freq (MHz)	LISN Factor (dB)	Cable Loss (dB)	Reading (dBUV)	Emission Level (dBUV)	Limits (dBUV)	Margin (dB)	Remark
1	0.17000	0.18	0.01	40.60	40.79	54.96	14.17	Average
2	0.17000	0.18	0.01	53.30	53.49	64.96	11.47	QP
3	0.55814	0.24	0.02	30.10	30.36	46.00	15.64	Average
4	0.55814	0.24	0.02	35.51	35.77	56.00	20.23	QP
5	0.72744	0.27	0.03	28.40	28.70	46.00	17.30	Average
6	0.72744	0.27	0.03	35.11	35.41	56.00	20.59	QP
7	0.89917	0.26	0.03	29.10	29.39	46.00	16.61	Average
8	0.89917	0.26	0.03	35.51	35.80	56.00	20.20	QP
9	1.055	0.26	0.03	33.40	33.69	46.00	12.31	Average
10	1.055	0.26	0.03	38.70	38.99	56.00	17.01	QP
11	1.210	0.26	0.03	27.20	27.49	46.00	18.51	Average
12	1.210	0.26	0.03	34.12	34.41	56.00	21.59	QP

Remarks: 1. Emission Level=LISN Factor+Cable Loss+Reading.
 2. If the average limit is met when using a quasi-peak detector, the EUT shall be deemed to meet both limits and measurement with average detector is unnecessary.

4. RADIATED EMISSION MEASUREMENT

4.1. Test Equipment

4.1.1. For frequency range 30MHz~1000MHz

Item	Equipment	Manufacturer	Model No.	Serial No.	Last Cal.	Cal. Interval
1	3#Chamber	AUDIX	N/A	N/A	Nov.24, 13	1 Year
2	EMI Spectrum	Agilent	E4407B	MY41440292	May.08, 13	1 Year
3	Test Receiver	Rohde & Schwarz	ESVS10	834468/011	May.08, 13	1 Year
4	Amplifier	HP	8447D	2648A04738	May.08, 13	1 Year
5	Bilog Antenna	TESEQ	CBL6112D	35375	May.30, 13	1 Year
6	RF Cable	MIYAZAKI	CFD400-NL	3# Chamber No.1	May.08, 13	1 Year
7	Coaxial Switch	Anritsu	MP59B	M74389	May.08, 13	1 Year

4.1.2. For frequency range 1GHz~2GHz

Item	Equipment	Manufacturer	Model No.	Serial No.	Last Cal.	Cal. Interval
1	Spectrum Analyzer	Agilent	E4407B	MY41440292	May.08, 13	1 Year
2	Horn Antenna	EMCO	3115	9607-4877	Aug.27, 13	1 Year
3	Amplifier	Agilent	8449B	3008A00863	May.08, 13	1 Year
4	RF Cable	Hubersuhner	SUCOFLEX106	77977/6	May.08, 13	1 Year
5	RF Cable	Hubersuhner	SUCOFLEX106	28616/2	May.08, 13	1 Year

4.2. Block Diagram of Test Setup

4.2.1. For frequency range 30MHz-1000MHz

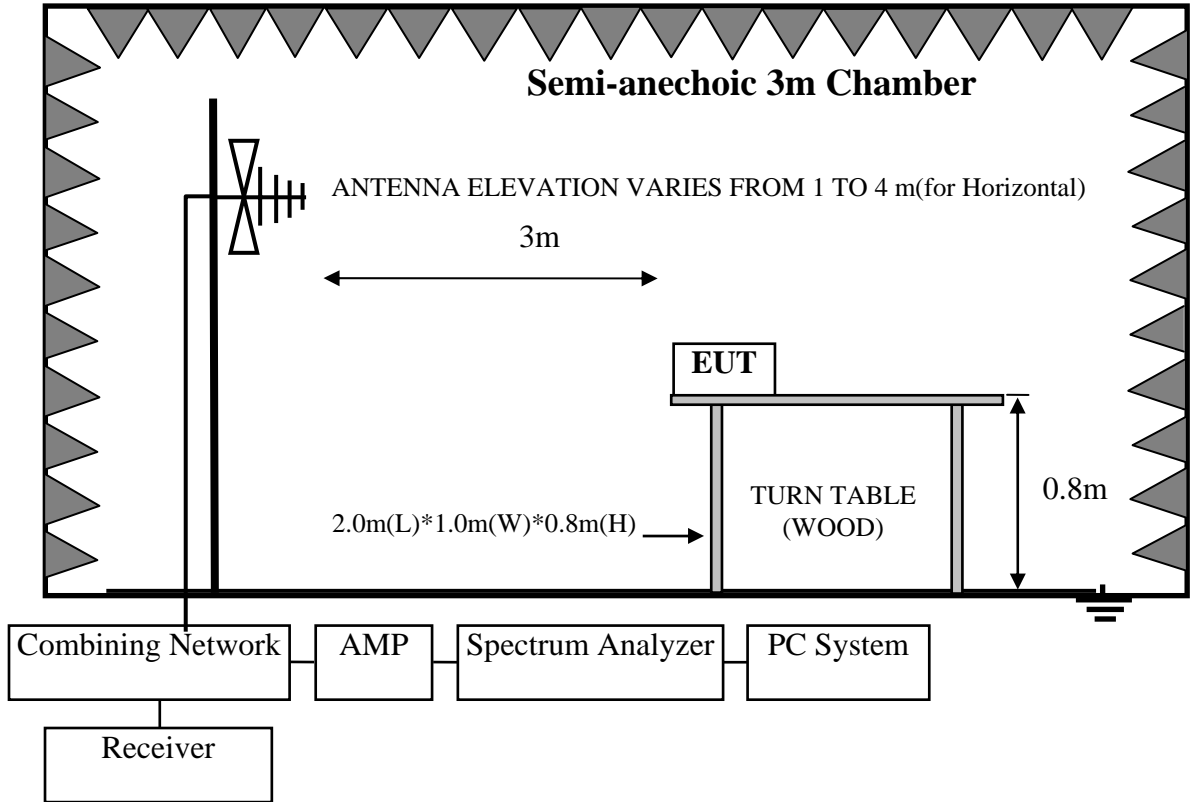

4.2.2. For frequency range 1GHz-2GHz

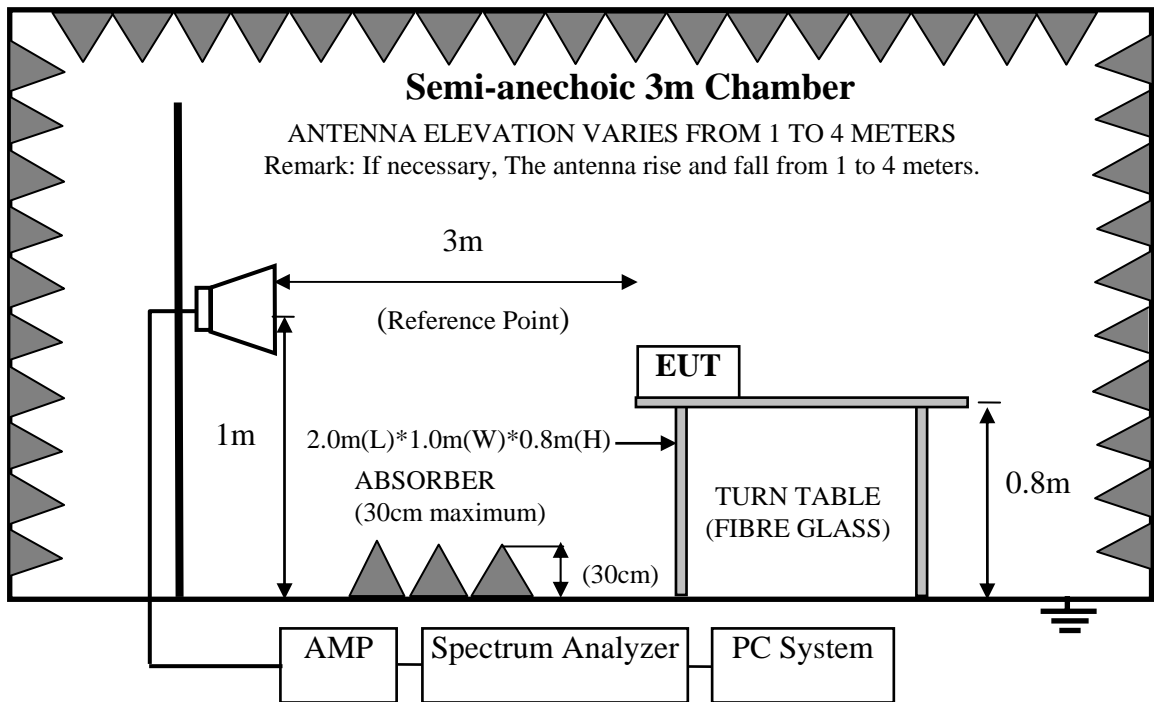

4.3. Radiated Emission Limit

Frequency MHz	Distance (Meters)	Field Strengths Limits dB(μV)/m
30 ~ 88	3	40.0
88 ~ 216	3	43.5
216 ~ 960	3	46.0
960 ~ 1000	3	54.0
Above 1000	3	74(Peak)54(Average)

- Remark: (1) Emission level = Antenna Factor + Cable Loss + Reading
Emission level = Antenna Factor - Amp Factor + Cable Loss + Reading
(above 1000MHz)
- (2) The smaller limit shall apply at the cross point between two frequency bands.
- (3) Distance is the distance in meters between the measuring instrument, antenna and the closest point of any part of the device or system.

4.4. EUT Configuration on Test

The configurations of EUT are listed in Section 3.4

4.5. Operating Condition of EUT

Same as Conducted Emission test that is listed in Section 3.5. except the test set up replaced by Section 4.2.

4.6. Test Procedure

The EUT was placed on a non-metallic table, 80 cm above the ground plane inside a semi-anechoic chamber. An antenna was located 3m from the EUT on an adjustable mast. A pre-scan was first performed in order to find prominent radiated emissions. For final emissions measurements at each frequency of interest, the EUT were rotated and the antenna height was varied between 1m and 4m in order to maximize the emission. Measurements in both horizontal and vertical polarities were made and the data was recorded. In order to find the maximum emission, the relative positions of equipments and all of the interface cables were changed according to ANSI C63.4: 2009 on Radiated Emission test.

The bandwidth of the EMI test receiver (R&S ESVS10) is set at 120kHz for frequency range from 30MHz to 1000 MHz.

The bandwidth of the Spectrum's RBW is set at 1MHz and VBW is set at 3MHz for peak emissions measurement above 1GHz and 1MHz RBW, 10Hz VBW for average emissions measure above 1GHz.

4.7. Radiated Emission Test Results

PASS. (All emissions not reported below are too low against the prescribed limits.)

EUT: LCD TV Model No. : 50FS5600

For frequency range 30MHz~1000MHz

The EUT with the following test modes were tested and selected to read Q.P values, all the test results are listed in next pages.

Test Date: Dec.14, 2013 Temperature: 24°C Humidity: 65%

The details of test modes are as follows :

No.	Test Mode	Input Port	Resolution & Frequency	Reference Test Data No.	
				Horizontal	Vertical
The Worst for Video Resolution of original report:					
1.	PC Mode	HDMI 1	1920*1080/60Hz	#33	#34
2.		HDMI 2	1920*1080/60Hz	#32	#31
3. ※		HDMI 3	1920*1080/60Hz	#30	#29

(※ Worst test mode)

For frequency range 1GHz~2GHz

The EUT with below test mode were measured within Anechoic Chamber and the test results listed in next pages

Note: For all the emissions above 1GHz, the peak measured level comply with peak limit, so the average level were deemed to comply with average limit.

Test Date: Dec.14, 2013 Temperature: 24°C Humidity: 56%

No.	Test Mode	Input Port	Resolution & Frequency	Reference Test Data No.	
				Horizontal	Vertical
The Worst for Video Resolution of original report:					
1.	PC Mode	HDMI 1	1920*1080/60Hz	#41	#42
2.		HDMI 2	1920*1080/60Hz	#44	#43
3. ※		HDMI 3	1920*1080/60Hz	#45	#46

(※ Worst test mode)

30MHz~1000MHz

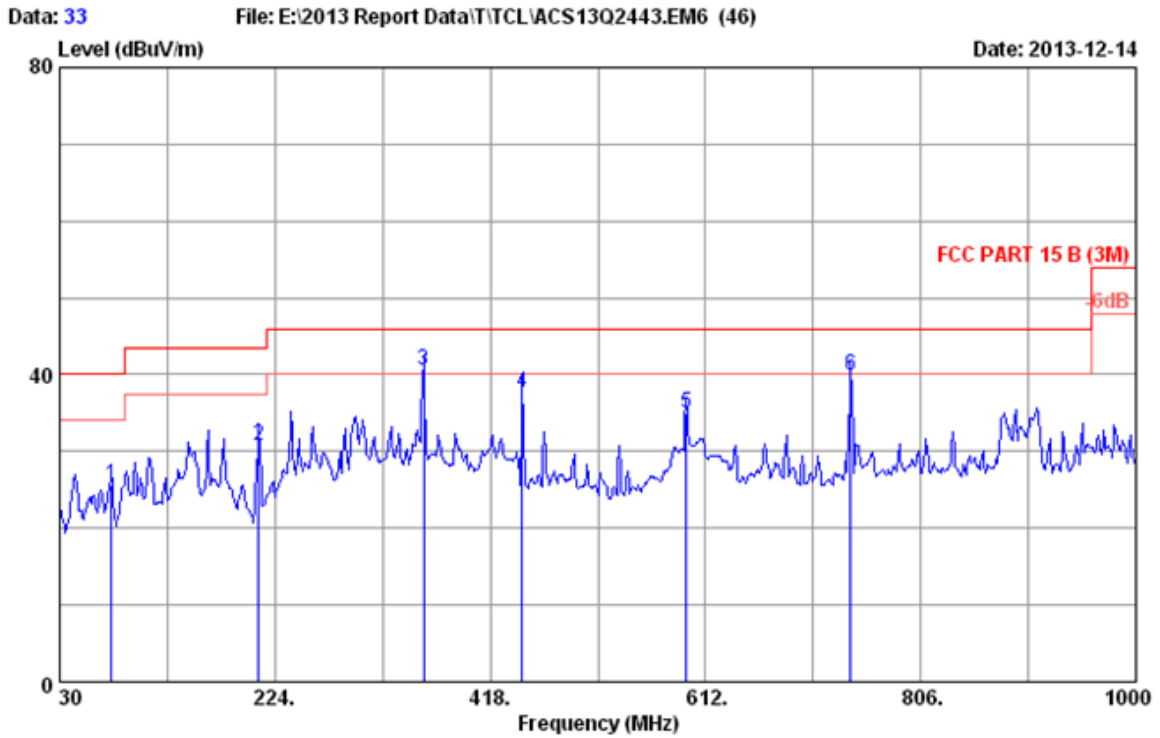

Site no. : 3m Chamber Data no. : 33
 Dis. / Ant. : 3m 2013 CBL6112D 35375 Ant. pol. : HORIZONTAL
 Limit : FCC PART 15 B (3M)
 Env. / Ins. : 24°C/65% Engineer : Even_Deng
 EUT : LCD TV M/N:50FS5600
 Power rating : AC 120V/60Hz
 Test Mode : Running"H"Pattern And 1KHz Playing
 HDMI1:1920*1080@60Hz

No.	Freq. (MHz)	Ant. Factor (dB/m)	Cable Loss (dB)	Reading (dBUV)	Emission Level (dBUV/m)	Limits (dBUV/m)	Margin (dB)	Remark
1	76.560	7.26	1.31	17.08	25.65	40.00	14.35	QP
2	209.450	10.63	1.83	18.26	30.72	43.50	12.78	QP
3	357.860	15.66	2.34	22.54	40.54	46.00	5.46	QP
4	447.100	17.14	2.60	17.91	37.65	46.00	8.35	QP
5	594.540	19.09	3.02	12.95	35.06	46.00	10.94	QP
6	742.950	20.30	3.45	16.19	39.94	46.00	6.06	QP

Remarks: 1. Emission Level= Antenna Factor + Cable Loss + Reading.
 2. The emission levels that are 20dB below the official limit are not reported.

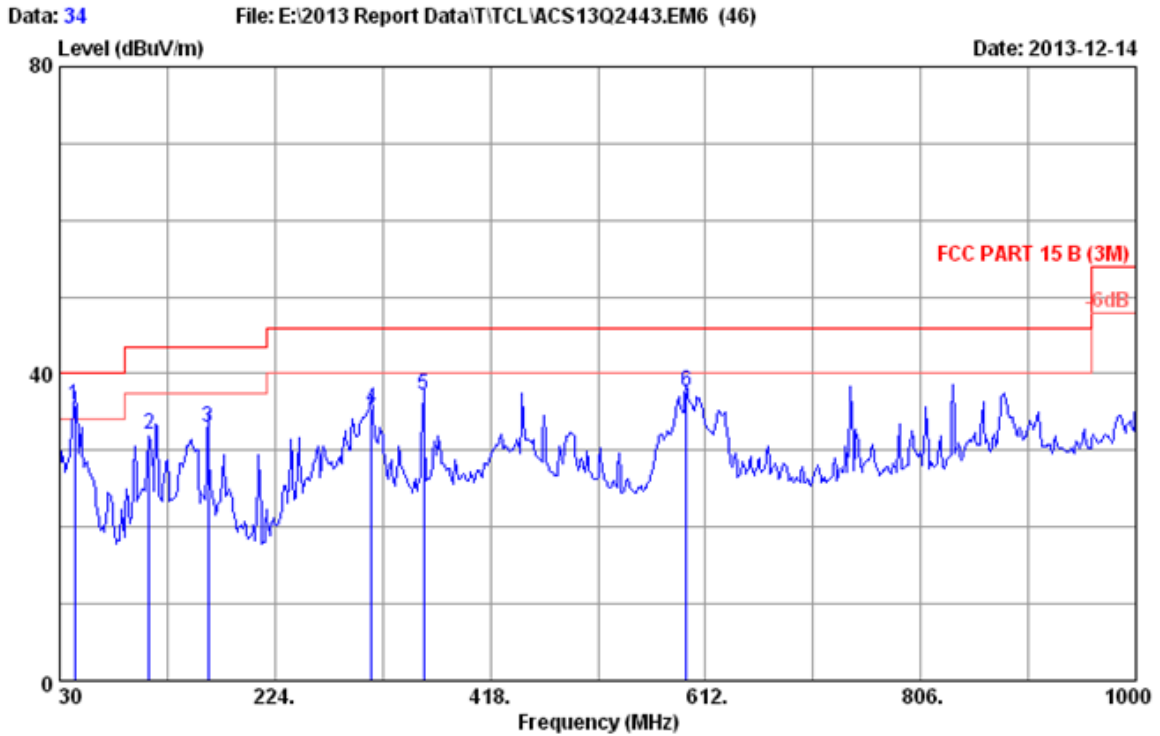

Site no. : 3m Chamber Data no. : 34
 Dis. / Ant. : 3m 2013 CBL6112D 35375 Ant. pol. : VERTICAL
 Limit : FCC PART 15 B (3M)
 Env. / Ins. : 24°C/65% Engineer : Even_Deng
 EUT : LCD TV M/N:50FS5600
 Power rating : AC 120V/60Hz
 Test Mode : Running"H"Pattern And 1KHz Playing
 HDMI1:1920*1080@60Hz

No.	Freq. (MHz)	Ant. Factor (dB/m)	Cable Loss (dB)	Reading (dBuV)	Emission Level (dBuV/m)	Limits (dBuV/m)	Margin (dB)	Remark
1	43.620	12.01	1.08	22.89	35.98	40.00	4.02	QP
2	110.630	12.33	1.45	18.40	32.18	43.50	11.32	QP
3	163.860	10.61	1.65	20.79	33.05	43.50	10.45	QP
4	311.300	14.23	2.20	18.90	35.33	46.00	10.67	QP
5	357.860	15.66	2.34	19.10	37.10	46.00	8.90	QP
6	594.540	19.09	3.02	15.46	37.57	46.00	8.43	QP

Remarks: 1. Emission Level= Antenna Factor + Cable Loss + Reading.
 2. The emission levels that are 20dB below the official limit are not reported.

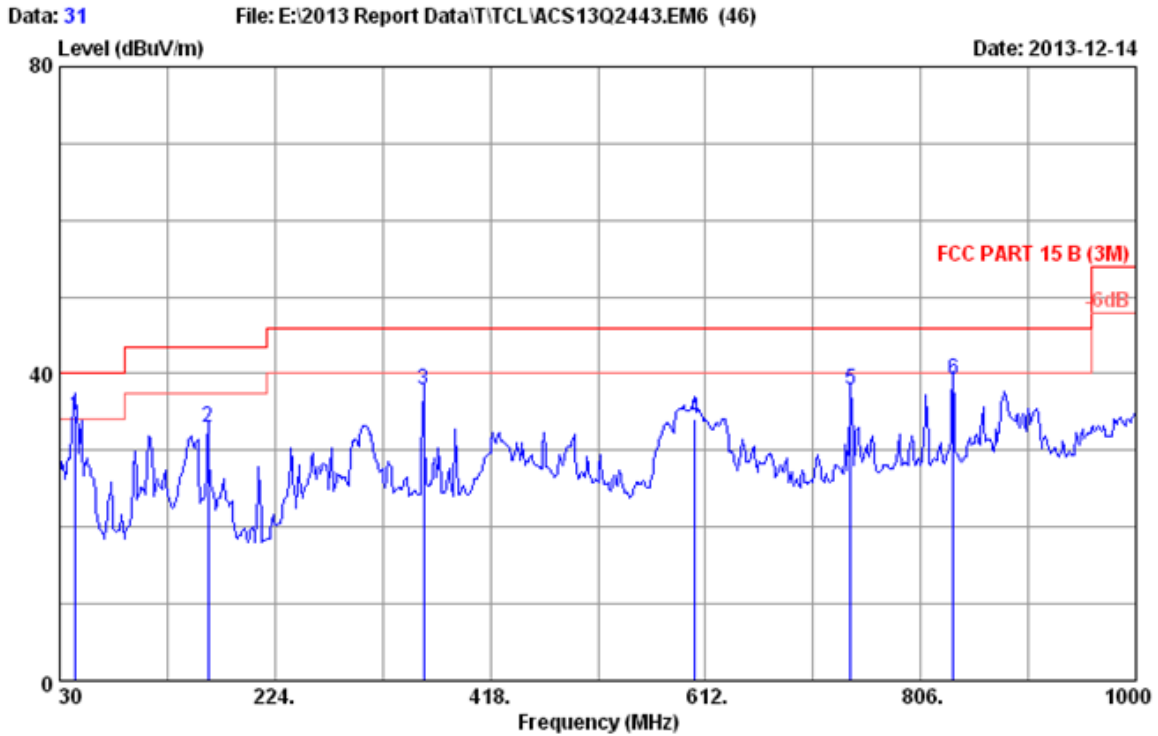

Site no. : 3m Chamber Data no. : 31
 Dis. / Ant. : 3m 2013 CBL6112D 35375 Ant. pol. : VERTICAL
 Limit : FCC PART 15 B (3M)
 Env. / Ins. : 24°C/65% Engineer : Even_Deng
 EUT : LCD TV M/N:50FS5600
 Power rating : AC 120V/60Hz
 Test Mode : Running"H"Pattern And 1KHz Playing
 HDMI2:1920*1080@60Hz

No.	Freq. (MHz)	Ant. Factor (dB/m)	Cable Loss (dB)	Reading (dBuV)	Emission Level (dBuV/m)	Limits (dBuV/m)	Margin (dB)	Remark
1	44.550	11.53	1.09	21.81	34.43	40.00	5.57	QP
2	163.860	10.61	1.65	20.64	32.90	43.50	10.60	QP
3	357.860	15.66	2.34	19.87	37.87	46.00	8.13	QP
4	602.300	19.20	3.04	11.76	34.00	46.00	12.00	QP
5	742.950	20.30	3.45	14.08	37.83	46.00	8.17	QP
6	835.100	21.10	3.72	14.43	39.25	46.00	6.75	QP

Remarks: 1. Emission Level= Antenna Factor + Cable Loss + Reading.
 2. The emission levels that are 20dB below the official limit are not reported.

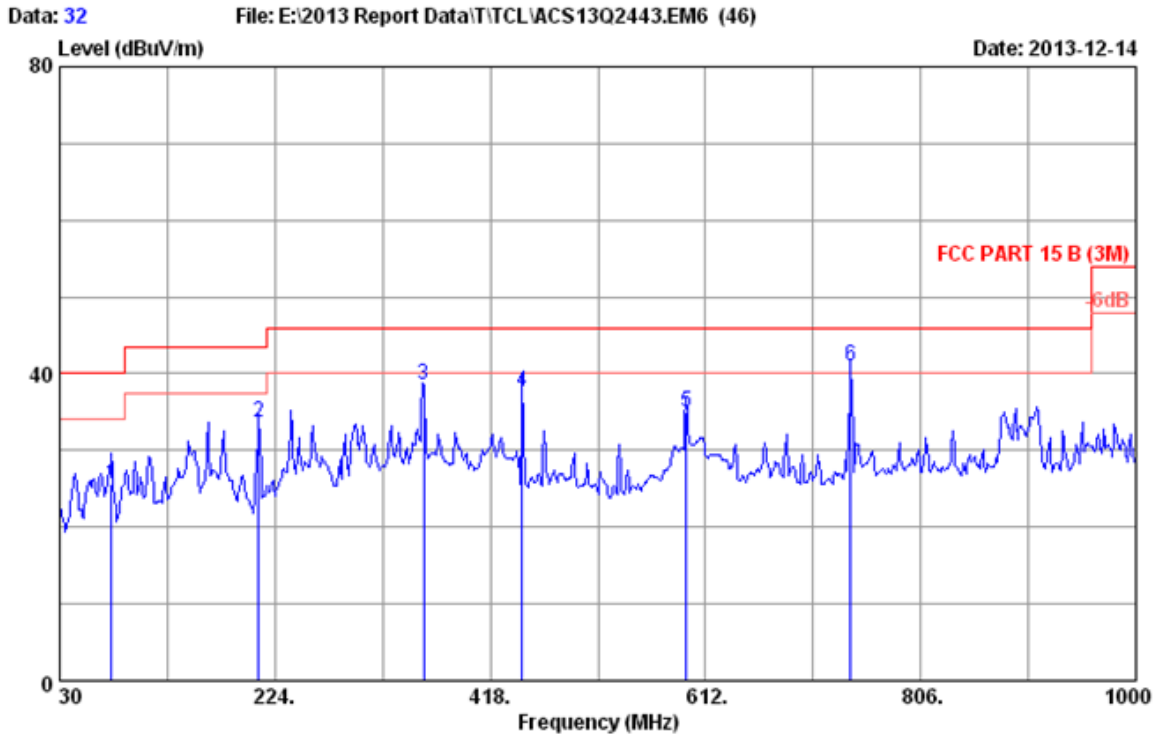

Site no. : 3m Chamber Data no. : 32
 Dis. / Ant. : 3m 2013 CBL6112D 35375 Ant. pol. : HORIZONTAL
 Limit : FCC PART 15 B (3M)
 Env. / Ins. : 24°C/65% Engineer : Even_Deng
 EUT : LCD TV M/N:50FS5600
 Power rating : AC 120V/60Hz
 Test Mode : Running"H"Pattern And 1KHz Playing
 HDMI2:1920*1080@60Hz

No.	Freq. (MHz)	Ant. Factor (dB/m)	Cable Loss (dB)	Reading (dBuV)	Emission Level (dBuV/m)	Limits (dBuV/m)	Margin (dB)	Remark
1	76.560	7.26	1.31	17.08	25.65	40.00	14.35	QP
2	209.450	10.63	1.83	21.26	33.72	43.50	9.78	QP
3	357.860	15.66	2.34	20.54	38.54	46.00	7.46	QP
4	447.100	17.14	2.60	17.91	37.65	46.00	8.35	QP
5	594.540	19.09	3.02	12.95	35.06	46.00	10.94	QP
6	742.950	20.30	3.45	17.19	40.94	46.00	5.06	QP

Remarks: 1. Emission Level= Antenna Factor + Cable Loss + Reading.
 2. The emission levels that are 20dB below the official limit are not reported.

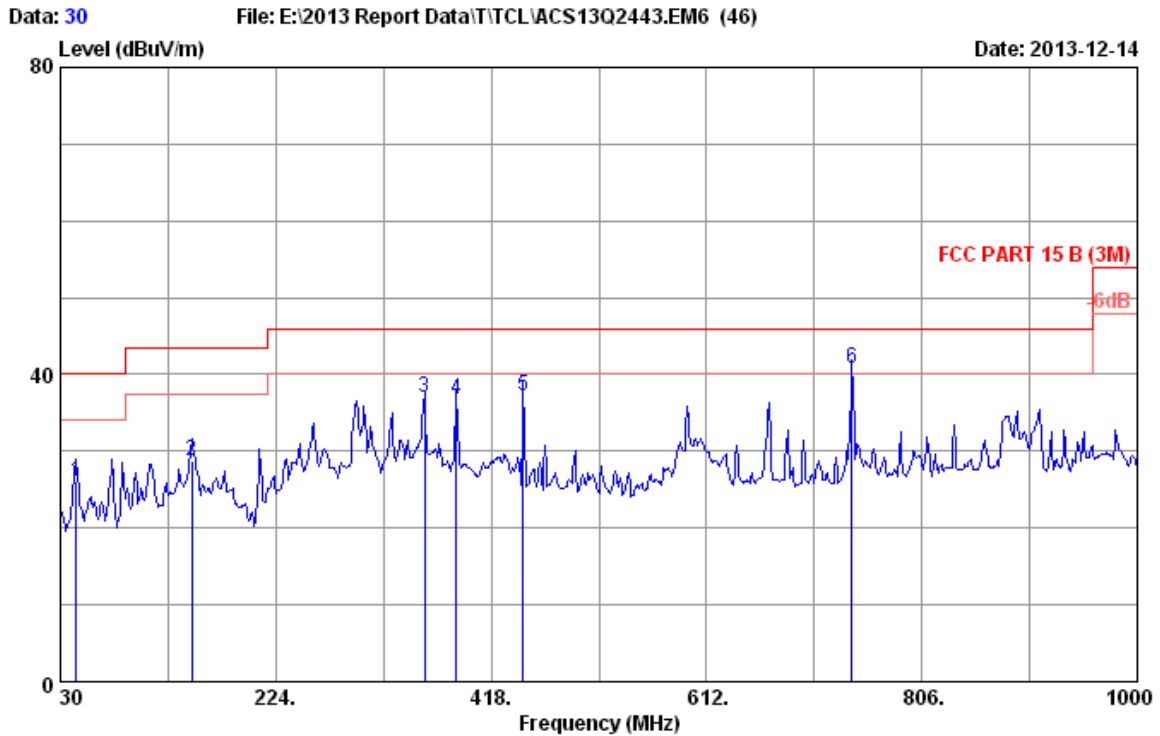

Site no. : 3m Chamber Data no. : 30
 Dis. / Ant. : 3m 2013 CBL6112D 35375 Ant. pol. : HORIZONTAL
 Limit : FCC PART 15 B (3M)
 Env. / Ins. : 24°C/65% Engineer : Even_Deng
 EUT : LCD TV M/N:50FS5600
 Power rating : AC 120V/60Hz
 Test Mode : Running"H"Pattern And 1KHz Playing
 HDMI3:1920*1080@60Hz

No.	Freq. (MHz)	Ant. Factor (dB/m)	Cable Loss (dB)	Reading (dBUV)	Emission Level (dBUV/m)	Limits (dBUV/m)	Margin (dB)	Remark
1	44.550	11.53	1.09	13.45	26.07	40.00	13.93	QP
2	148.340	11.38	1.59	15.72	28.69	43.50	14.81	QP
3	357.860	15.66	2.34	18.94	36.94	46.00	9.06	QP
4	386.960	16.08	2.42	18.28	36.78	46.00	9.22	QP
5	447.100	17.14	2.60	17.57	37.31	46.00	8.69	QP
6	742.950	20.30	3.45	17.09	40.84	46.00	5.16	QP

Remarks: 1. Emission Level= Antenna Factor + Cable Loss + Reading.
 2. The emission levels that are 20dB below the official limit are not reported.
 3. The worst emission was detected at 742.950 MHz with corrected signal level of 40.84 dBUV/m (Limit is 46.00 dBUV/m) when the antenna was at horizontal polarization and at 1.0m high and the turn table was at 75°.
 4. 0° was the table front facing the antenna. Degree is calculated from 0° clockwise facing the antenna.

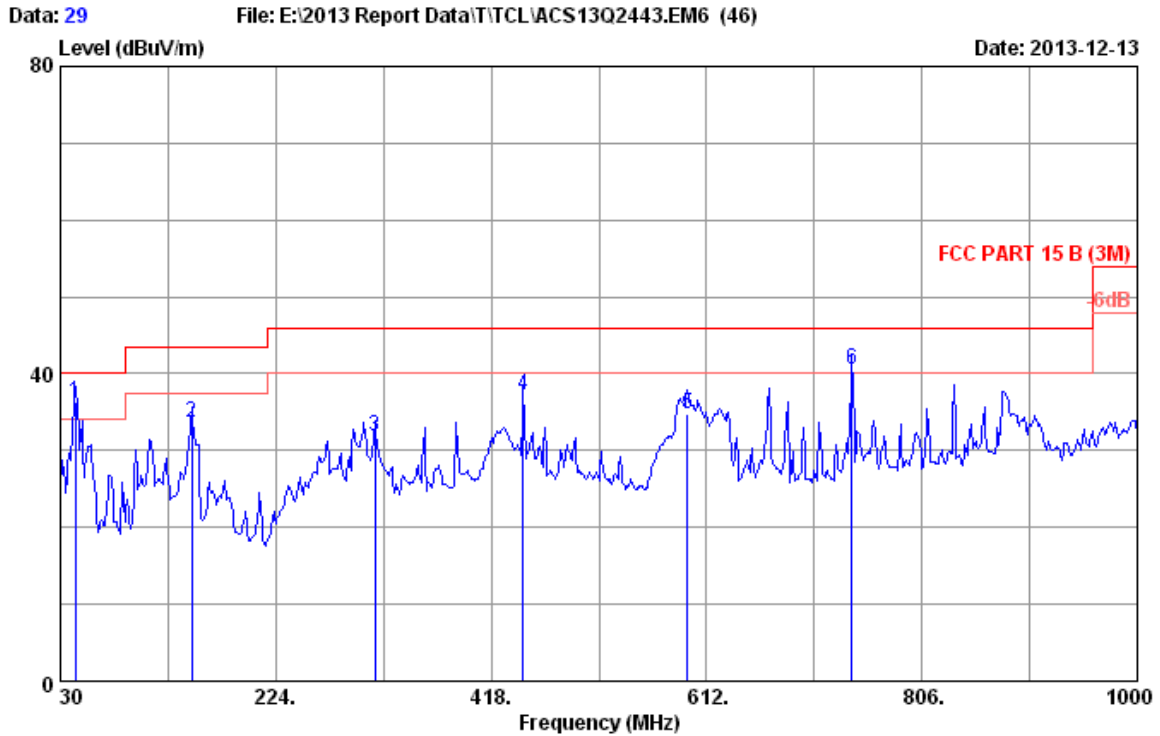

Site no. : 3m Chamber Data no. : 29
 Dis. / Ant. : 3m 2013 CBL6112D 35375 Ant. pol. : VERTICAL
 Limit : FCC PART 15 B (3M)
 Env. / Ins. : 24°C/65% Engineer : Even_Deng
 EUT : LCD TV M/N:50FS5600
 Power rating : AC 120V/60Hz
 Test Mode : Running"H"Pattern And 1KHz Playing
 HDMI3:1920*1080@60Hz

No.	Freq. (MHz)	Ant. Factor (dB/m)	Cable Loss (dB)	Reading (dBUV)	Emission Level (dBUV/m)	Limits (dBUV/m)	Margin (dB)	Remark
1	43.600	12.02	1.07	23.30	36.39	40.00	3.61	QP
2	148.340	11.38	1.59	20.62	33.59	43.50	9.91	QP
3	313.240	14.26	2.21	15.33	31.80	46.00	14.20	QP
4	447.100	17.14	2.60	17.53	37.27	46.00	8.73	QP
5	594.540	19.09	3.02	12.75	34.86	46.00	11.14	QP
6	742.950	20.30	3.45	16.79	40.54	46.00	5.46	QP

- Remarks:
- Emission Level= Antenna Factor + Cable Loss + Reading.
 - The emission levels that are 20dB below the official limit are not reported.
 - The worst emission was detected at 43.600 MHz with corrected signal level of 36.39 dBμV/m (Limit is 40.00 dBμV/m) when the antenna was at vertical polarization and at 1.0m high and the turn table was at 235°.
 - 0° was the table front facing the antenna. Degree is calculated from 0° clockwise facing the antenna.

1~2GHz

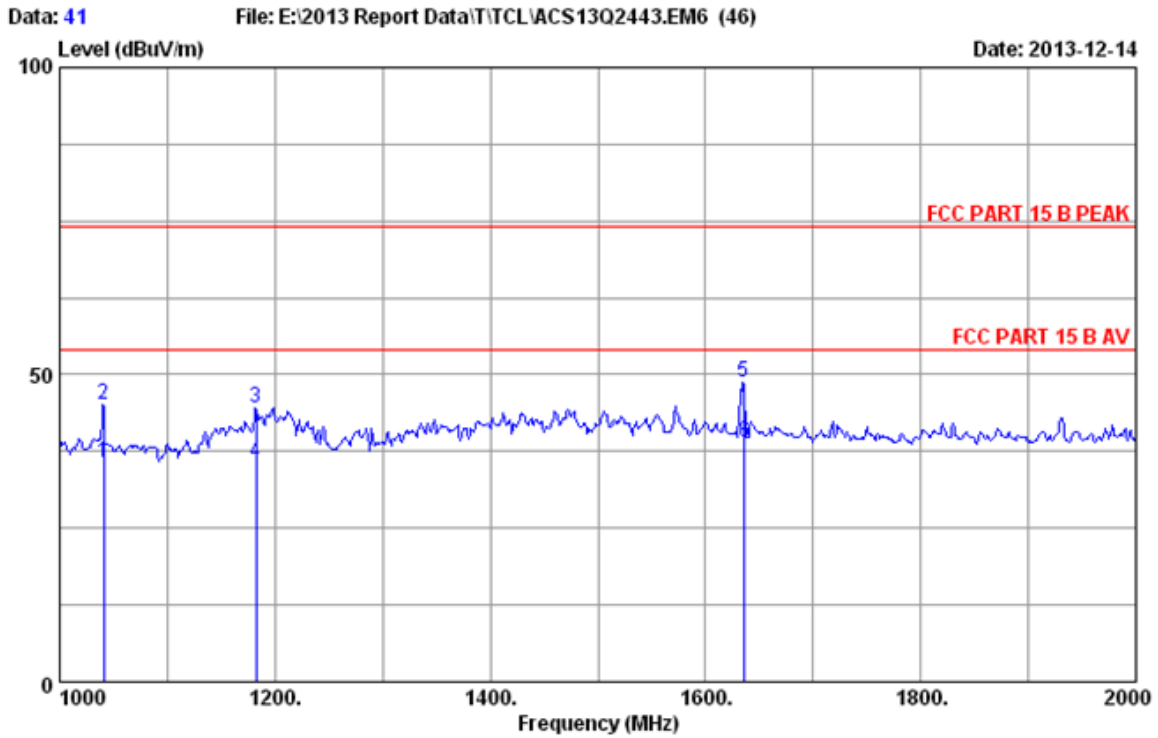

Site no. : 3m chamber (RF) Data no. : 41
 Dis. / Ant. : 3m 2013 3115 (4877) Ant. pol. : HORIZONTAL
 Limit : FCC PART 15 B PEAK
 Env. / Ins. : 24°C/56% Engineer : Even_Deng
 EUT : LCD TV M/N:50FS5600
 Power Rating : AC 120V/60Hz
 Test Mode : Running "H" Pattern And 1KHz Playing
 HDMI1:1920*1080@60Hz

No.	Freq. (MHz)	Ant. Factor (dB/m)	Cable Loss (dB)	AMP factor (dB)	Reading (dBuV)	Emission Level (dBuV/m)	Limits (dBuV/m)	Margin (dB)	Remark
1	1040.566	23.58	1.48	36.24	46.85	35.67	54.00	18.33	Average
2	1040.895	23.58	1.48	36.24	56.32	45.14	74.00	28.86	Peak
3	1182.050	24.20	1.60	36.03	54.84	44.61	74.00	29.39	Peak
4	1182.726	24.20	1.60	36.03	45.92	35.69	54.00	18.31	Average
5	1635.465	25.74	2.01	35.35	56.28	48.68	74.00	25.32	Peak
6	1636.150	25.74	2.02	35.35	46.52	38.93	54.00	15.07	Average

Remarks: 1. Emission Level= Antenna Factor + Cable Loss + Reading - Amp Factor
 2. The emission levels that are 20dB below the official limit are not reported.

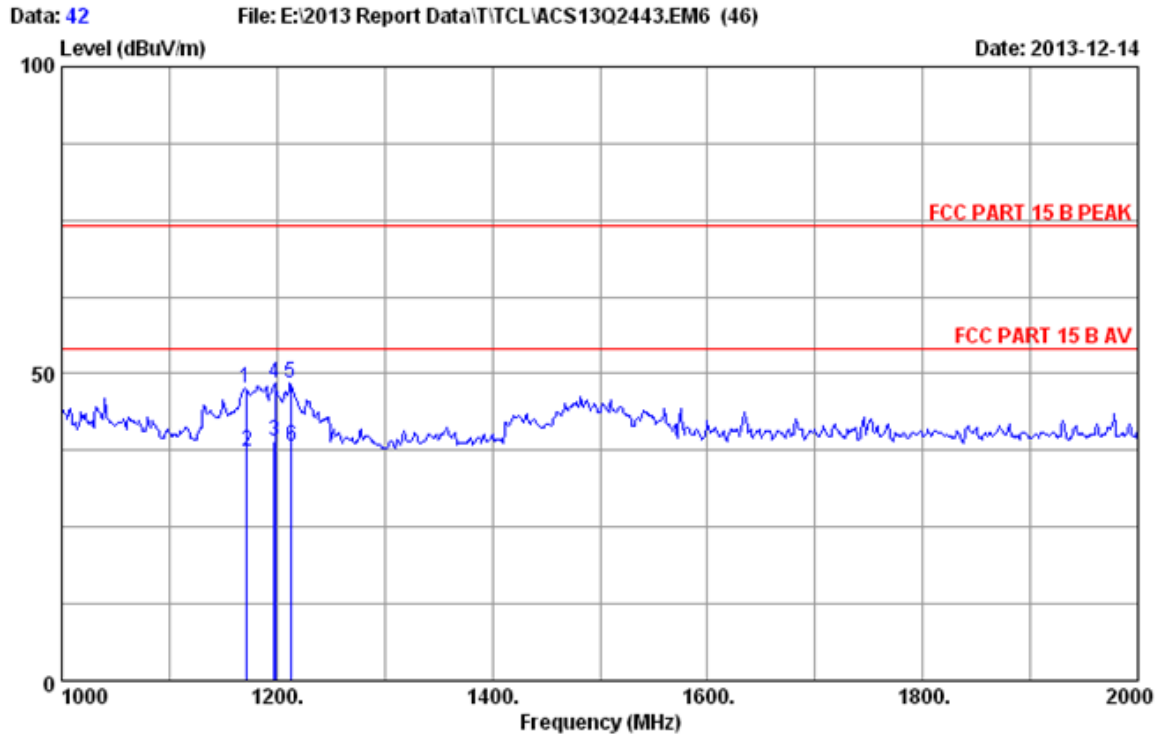

Site no. : 3m chamber (RF) Data no. : 42
 Dis. / Ant. : 3m 2013 3115 (4877) Ant. pol. : VERTICAL
 Limit : FCC PART 15 B PEAK
 Env. / Ins. : 24°C/56% Engineer : Even_Deng
 EUT : LCD TV M/N:50FS5600
 Power Rating : AC 120V/60Hz
 Test Mode : Running "H" Pattern And 1KHz Playing
 HDMI1:1920*1080@60Hz

No.	Freq. (MHz)	Ant. Factor (dB/m)	Cable Loss (dB)	AMP factor (dB)	Reading (dBUV)	Emission Level (dBUV/m)	Limits (dBUV/m)	Margin (dB)	Remark
1	1170.960	24.15	1.59	36.04	57.88	47.58	74.00	26.42	Peak
2	1171.856	24.16	1.59	36.04	47.58	37.29	54.00	16.71	Average
3	1197.594	24.27	1.61	36.00	49.20	39.08	54.00	14.92	Average
4	1198.285	24.27	1.61	36.00	58.51	48.39	74.00	25.61	Peak
5	1212.650	24.34	1.62	35.98	58.45	48.43	74.00	25.57	Peak
6	1213.526	24.34	1.63	35.98	48.05	38.04	54.00	15.96	Average

Remarks: 1. Emission Level= Antenna Factor + Cable Loss + Reading - Amp Factor
 2. The emission levels that are 20dB below the official limit are not reported.

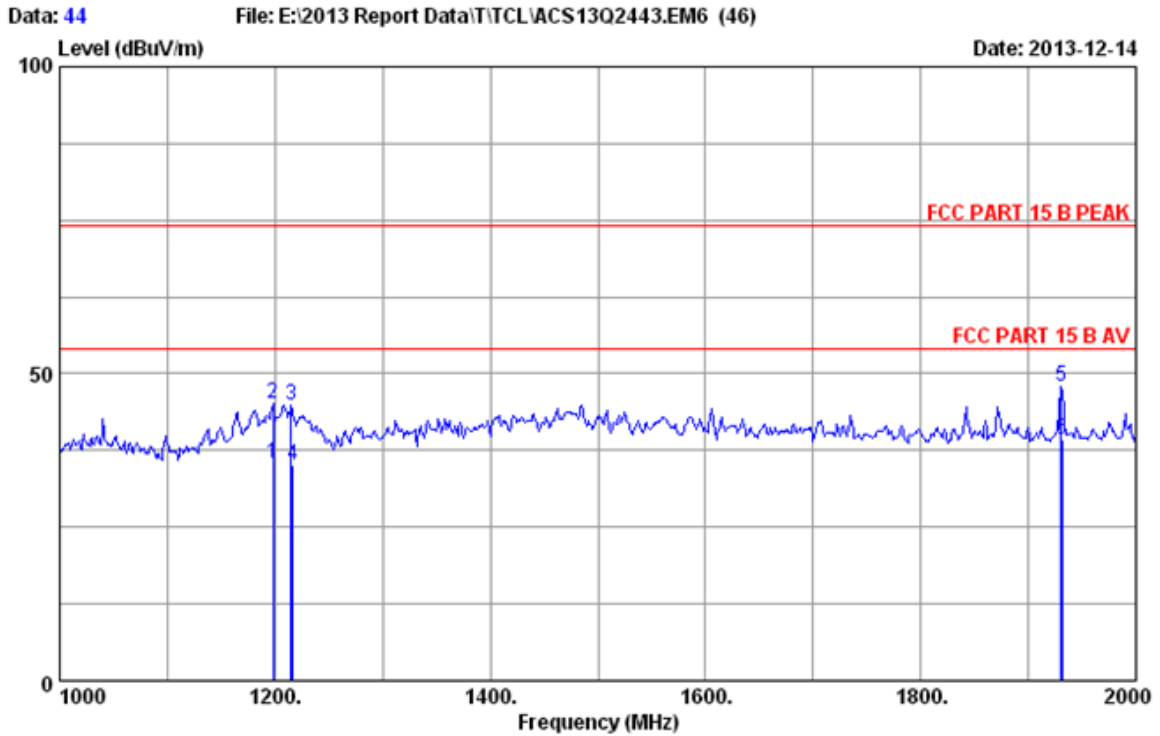

Site no. : 3m chamber (RF) Data no. : 44
 Dis. / Ant. : 3m 2013 3115 (4877) Ant. pol. : HORIZONTAL
 Limit : FCC PART 15 B PEAK
 Env. / Ins. : 24°C/56% Engineer : Even_Deng
 EUT : LCD TV M/N:50FS5600
 Power Rating : AC 120V/60Hz
 Test Mode : Running "H" Pattern And 1KHz Playing
 HDMI2:1920*1080@60Hz

No.	Freq. (MHz)	Ant. Factor (dB/m)	Cable Loss (dB)	AMP factor (dB)	Reading (dBUV)	Emission Level (dBUV/m)	Limits (dBUV/m)	Margin (dB)	Remark
1	1198.052	24.27	1.61	36.00	45.62	35.50	54.00	18.50	Average
2	1198.160	24.27	1.61	36.00	55.23	45.11	74.00	28.89	Peak
3	1215.065	24.35	1.63	35.98	54.97	44.97	74.00	29.03	Peak
4	1216.585	24.35	1.63	35.98	45.06	35.06	54.00	18.94	Average
5	1930.063	26.03	2.35	34.90	54.30	47.78	74.00	26.22	Peak
6	1931.579	26.03	2.35	34.90	45.81	39.29	54.00	14.71	Average

Remarks: 1. Emission Level= Antenna Factor + Cable Loss + Reading - Amp Factor
 2. The emission levels that are 20dB below the official limit are not reported.

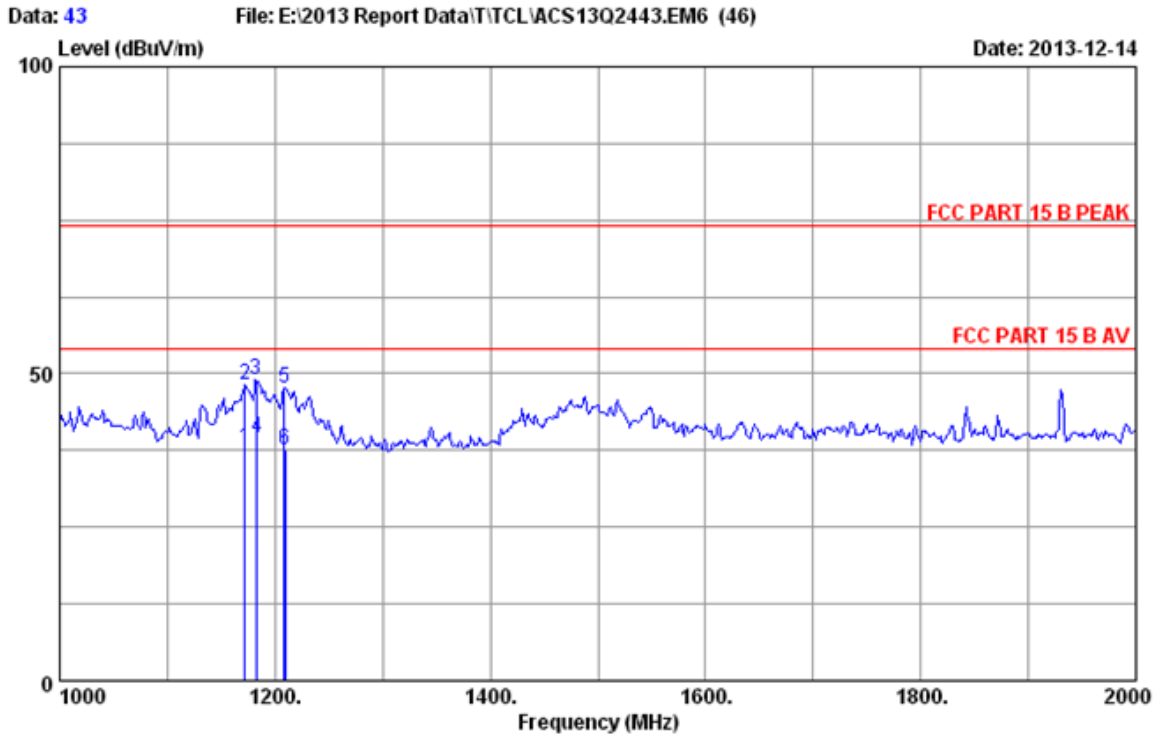

Site no. : 3m chamber (RF) Data no. : 43
 Dis. / Ant. : 3m 2013 3115 (4877) Ant. pol. : VERTICAL
 Limit : FCC PART 15 B PEAK
 Env. / Ins. : 24°C/56% Engineer : Even_Deng
 EUT : LCD TV M/N:50FS5600
 Power Rating : AC 120V/60Hz
 Test Mode : Running "H" Pattern And 1KHz Playing
 HDMI2:1920*1080@60Hz

No.	Freq. (MHz)	Ant. Factor (dB/m)	Cable Loss (dB)	AMP factor (dB)	Reading (dBuV)	Emission Level (dBuV/m)	Limits (dBuV/m)	Margin (dB)	Remark
1	1171.860	24.16	1.59	36.04	48.25	37.96	54.00	16.04	Average
2	1172.460	24.16	1.59	36.04	58.56	48.27	74.00	25.73	Peak
3	1182.557	24.20	1.60	36.03	59.18	48.95	74.00	25.05	Peak
4	1183.548	24.21	1.60	36.02	49.75	39.54	54.00	14.46	Average
5	1208.679	24.32	1.62	35.99	57.73	47.68	74.00	26.32	Peak
6	1209.725	24.32	1.62	35.99	47.70	37.65	54.00	16.35	Average

Remarks: 1. Emission Level= Antenna Factor + Cable Loss + Reading - Amp Factor
 2. The emission levels that are 20dB below the official limit are not reported.

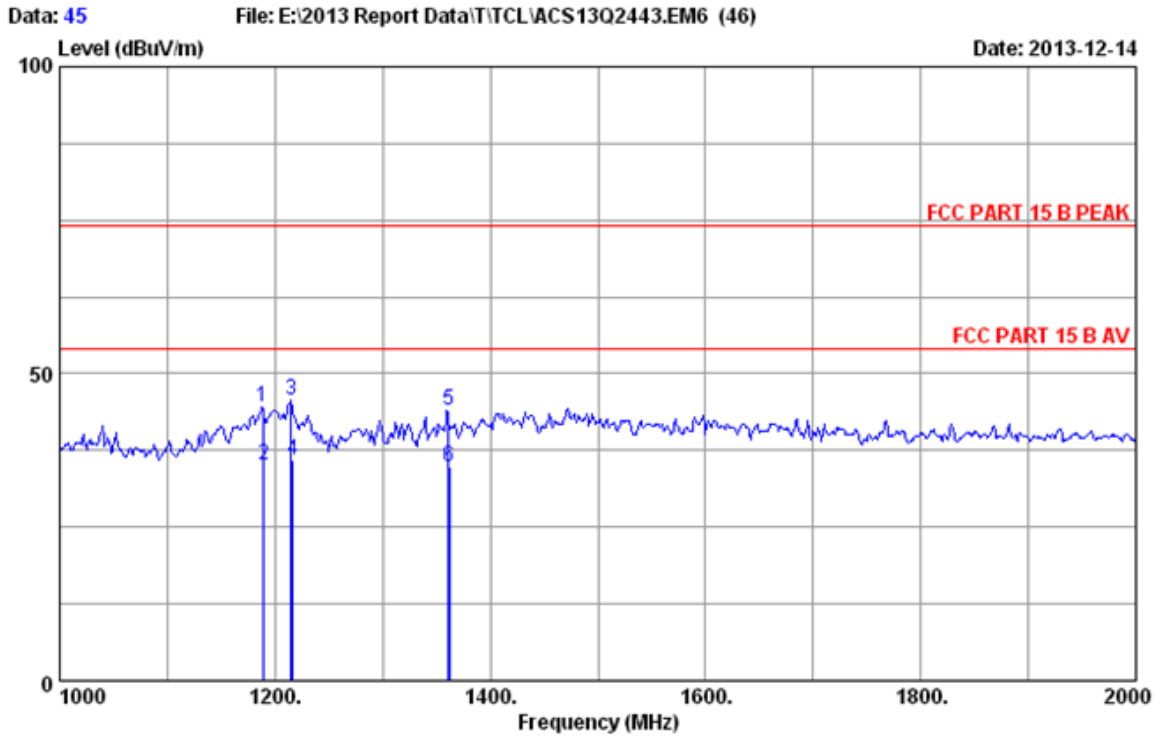

Site no. : 3m chamber (RF) Data no. : 45
 Dis. / Ant. : 3m 2013 3115 (4877) Ant. pol. : HORIZONTAL
 Limit : FCC PART 15 B PEAK
 Env. / Ins. : 24°C/56% Engineer : Even_Deng
 EUT : LCD TV M/N:50FS5600
 Power Rating : AC 120V/60Hz
 Test Mode : Running "H" Pattern And 1KHz Playing
 HDMI3:1920*1080@60Hz

No.	Freq. (MHz)	Ant. Factor (dB/m)	Cable Loss (dB)	AMP factor (dB)	Reading (dBuV)	Emission Level (dBuV/m)	Limits (dBuV/m)	Margin (dB)	Remark
1	1188.650	24.23	1.60	36.02	54.68	44.49	74.00	29.51	Peak
2	1189.453	24.23	1.61	36.02	45.16	34.98	54.00	19.02	Average
3	1215.065	24.35	1.63	35.98	55.55	45.55	74.00	28.45	Peak
4	1216.286	24.35	1.63	35.98	45.90	35.90	54.00	18.10	Average
5	1360.965	24.99	1.75	35.76	52.91	43.89	74.00	30.11	Peak
6	1361.788	24.99	1.75	35.76	43.80	34.78	54.00	19.22	Average

Remarks: 1. Emission Level= Antenna Factor + Cable Loss + Reading - Amp Factor
 2. The emission levels that are 20dB below the official limit are not reported.

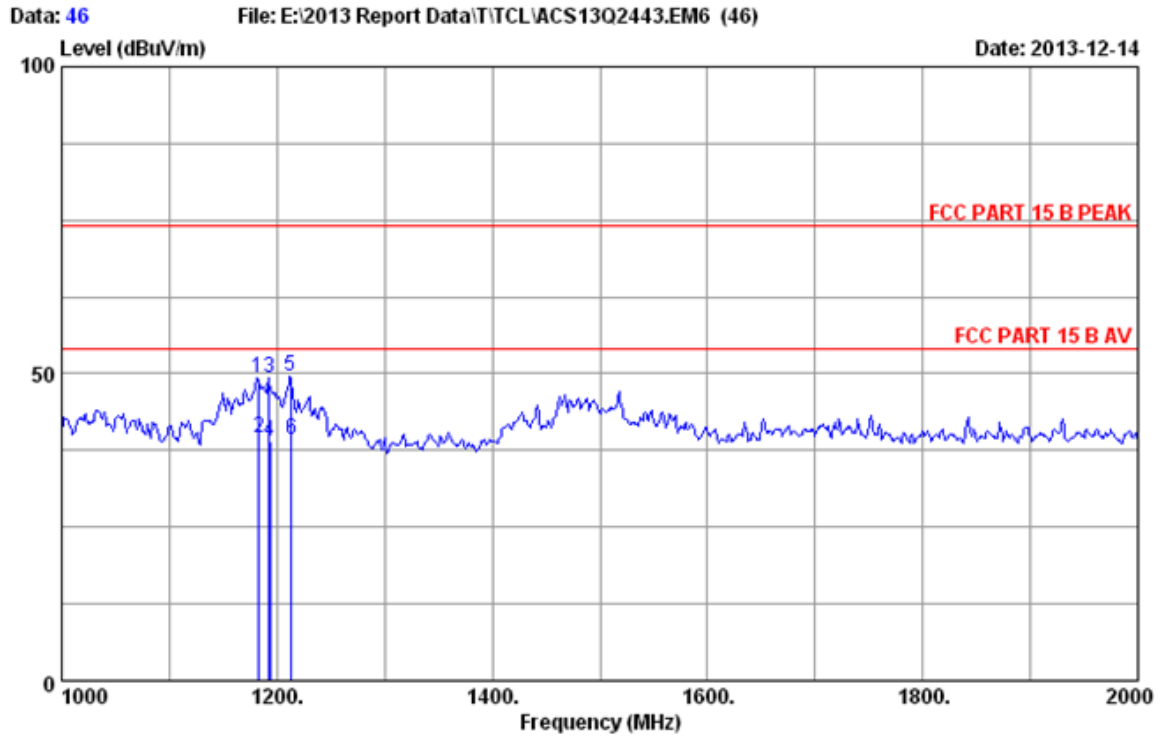

Site no. : 3m chamber (RF) Data no. : 46
 Dis. / Ant. : 3m 2013 3115 (4877) Ant. pol. : VERTICAL
 Limit : FCC PART 15 B PEAK
 Env. / Ins. : 24°C/56% Engineer : Even_Deng
 EUT : LCD TV M/N:50FS5600
 Power Rating : AC 120V/60Hz
 Test Mode : Running "H" Pattern And 1KHz Playing
 HDMI3:1920*1080@60Hz

No.	Freq. (MHz)	Ant. Factor (dB/m)	Cable Loss (dB)	AMP factor (dB)	Reading (dBuV)	Emission Level (dBuV/m)	Limits (dBuV/m)	Margin (dB)	Remark
1	1182.303	24.20	1.60	36.03	59.54	49.31	74.00	24.69	Peak
2	1183.450	24.21	1.60	36.02	49.84	39.63	54.00	14.37	Average
3	1192.640	24.25	1.61	36.01	59.54	49.39	74.00	24.61	Peak
4	1193.495	24.25	1.61	36.01	49.27	39.12	54.00	14.88	Average
5	1212.755	24.34	1.62	35.98	59.62	49.60	74.00	24.40	Peak
6	1213.542	24.34	1.63	35.98	49.37	39.36	54.00	14.64	Average

Remarks: 1. Emission Level= Antenna Factor + Cable Loss + Reading - Amp Factor
 2. The emission levels that are 20dB below the official limit are not reported.

5. DEVIATION TO TEST SPECIFICATIONS

[NONE]

6. PHOTOGRAPH

6.1. Photos of Power Line Conducted Emission Test



6.2.Photos of Radiated Emission Test (In Anechoic Chamber)





Frequency range above 1GHz



7. PHOTOS OF THE EUT

Figure 1
General Appearance of the EUT



Figure 2
General Appearance of the EUT



Figure 3
General Appearance of the EUT



Figure 4
General Appearance of the EUT



Figure 5
Signal Port of the EUT



Figure 6
Signal Port of the EUT



Figure 7
Signal Port of the EUT



Figure 8
Inside Configuration of the EUT



Figure 9
Inside Configuration of the EUT



Figure 10
Inside Configuration of the EUT



Figure 11
Inside Configuration of the EUT

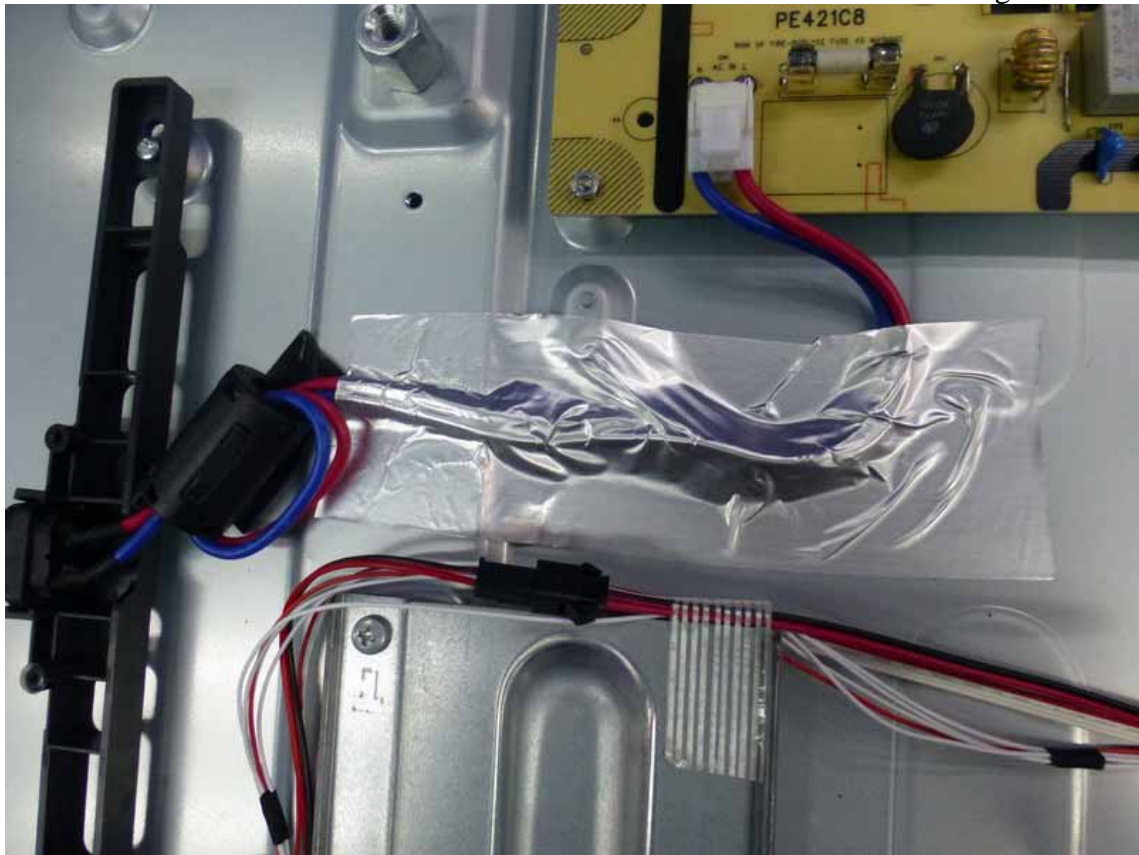

Figure 12
Inside Configuration of the EUT



Figure 13
Frontside of the LCD Panel



Figure 14
Backside of the LCD Panel



Figure 15
Label of the LCD Panel



Figure 16
Frontside of the Main Board

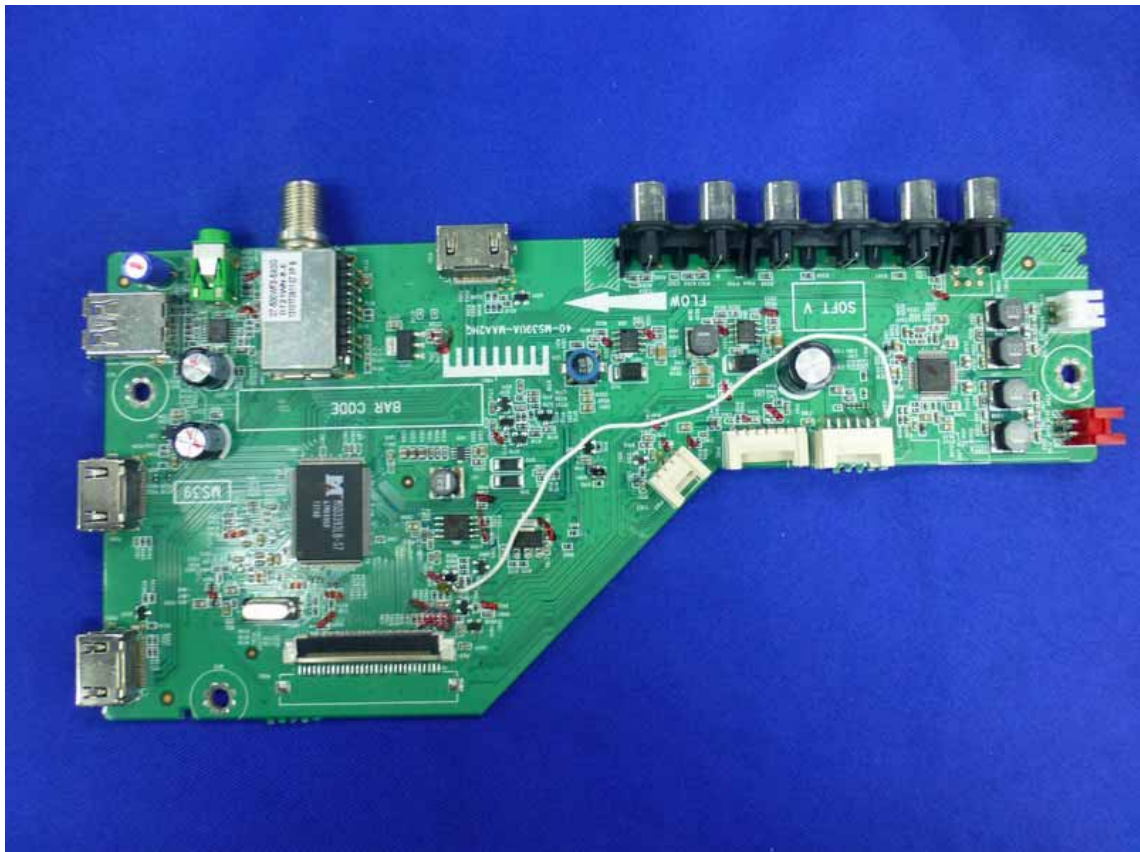

Figure 17
Backside of the Main Board

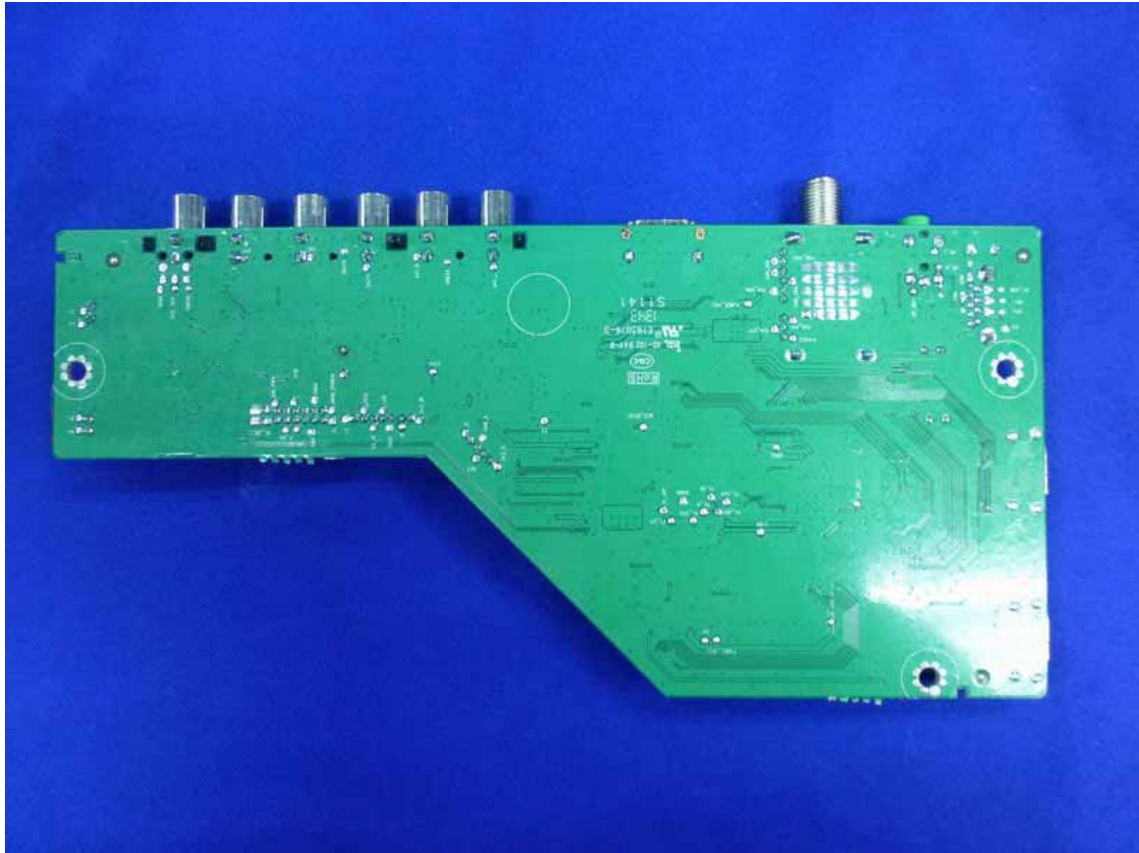

Figure 18
Frontside of the Main Board

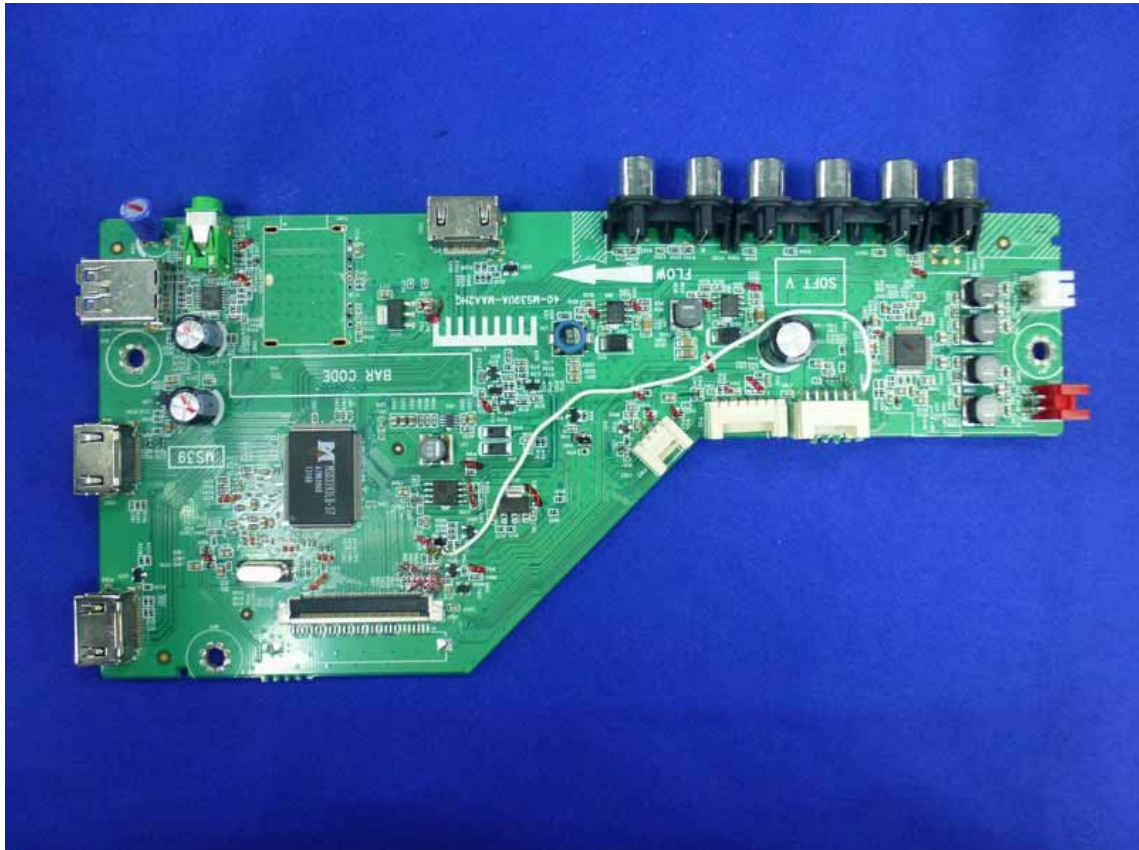

Figure 19
Backside of the Main Board

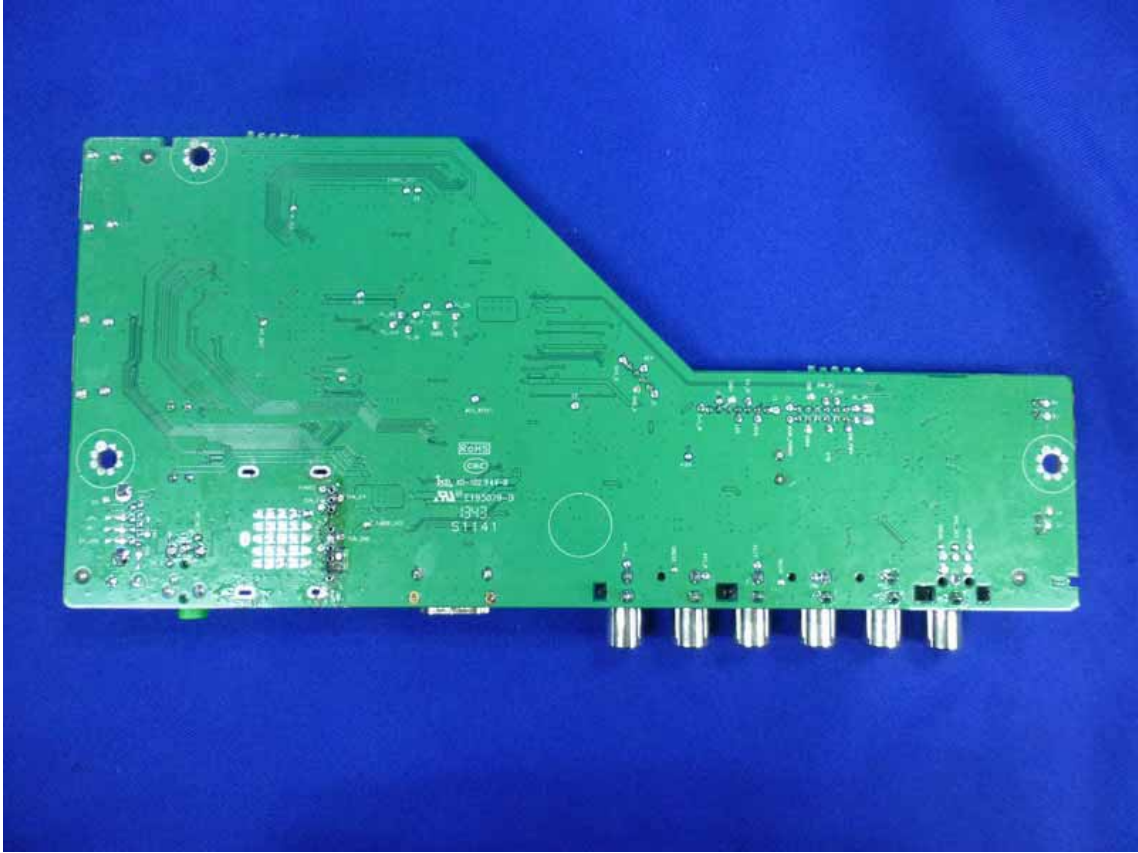

Figure 20
Frontside of the Main Board

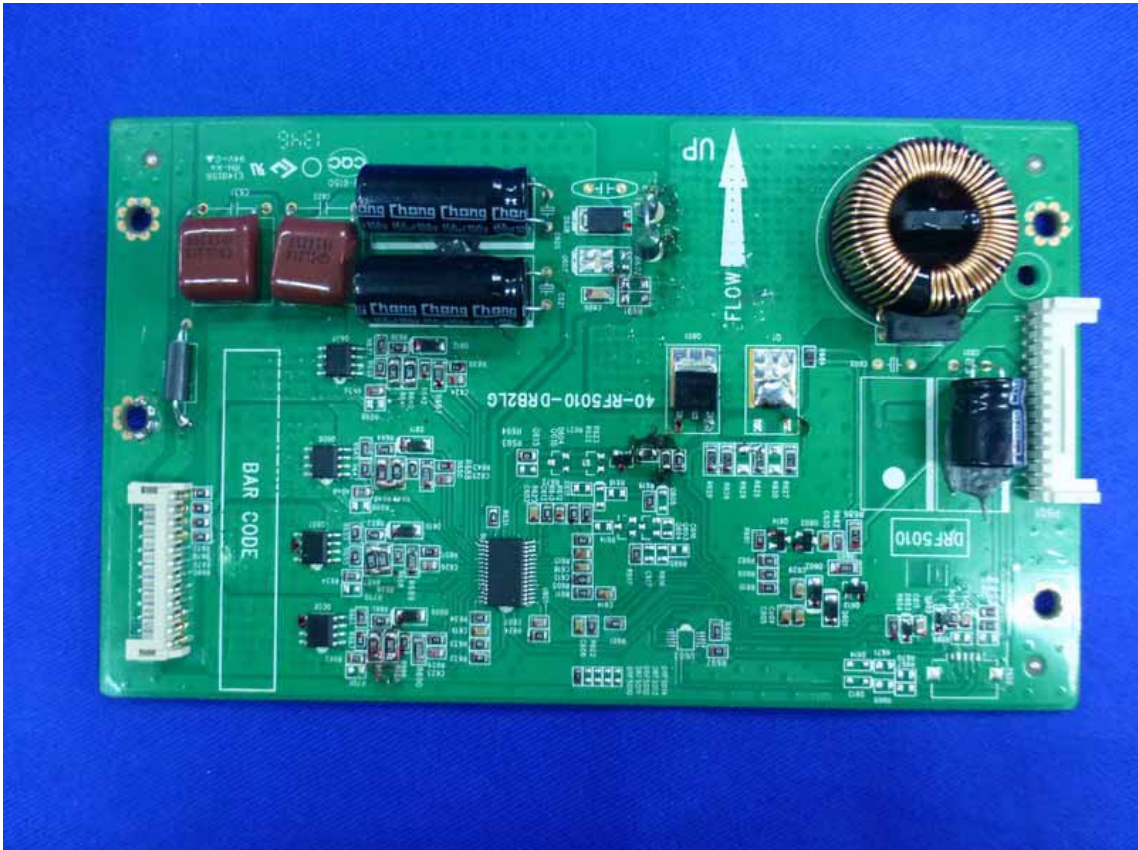

Figure 21
Backside of the Main Board

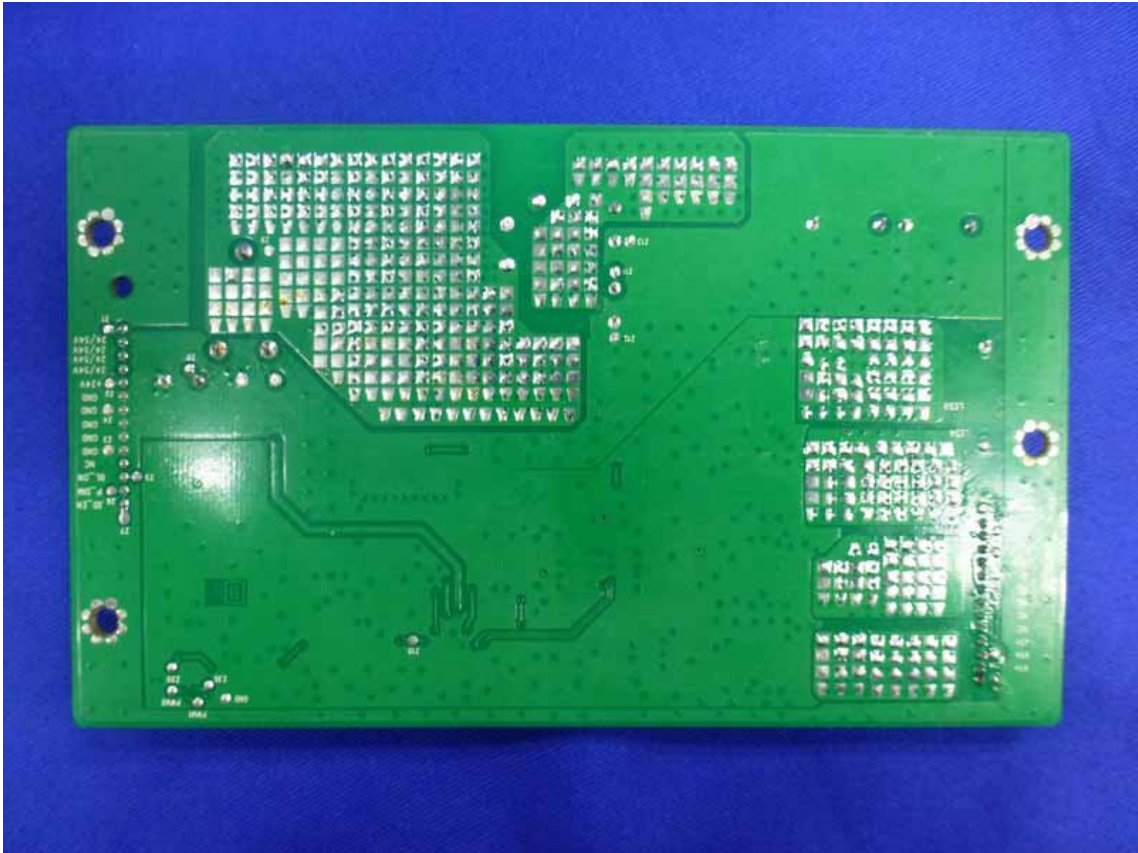

Figure 22
Frontside of the Power Board



Figure 23
Backside of the Power Board

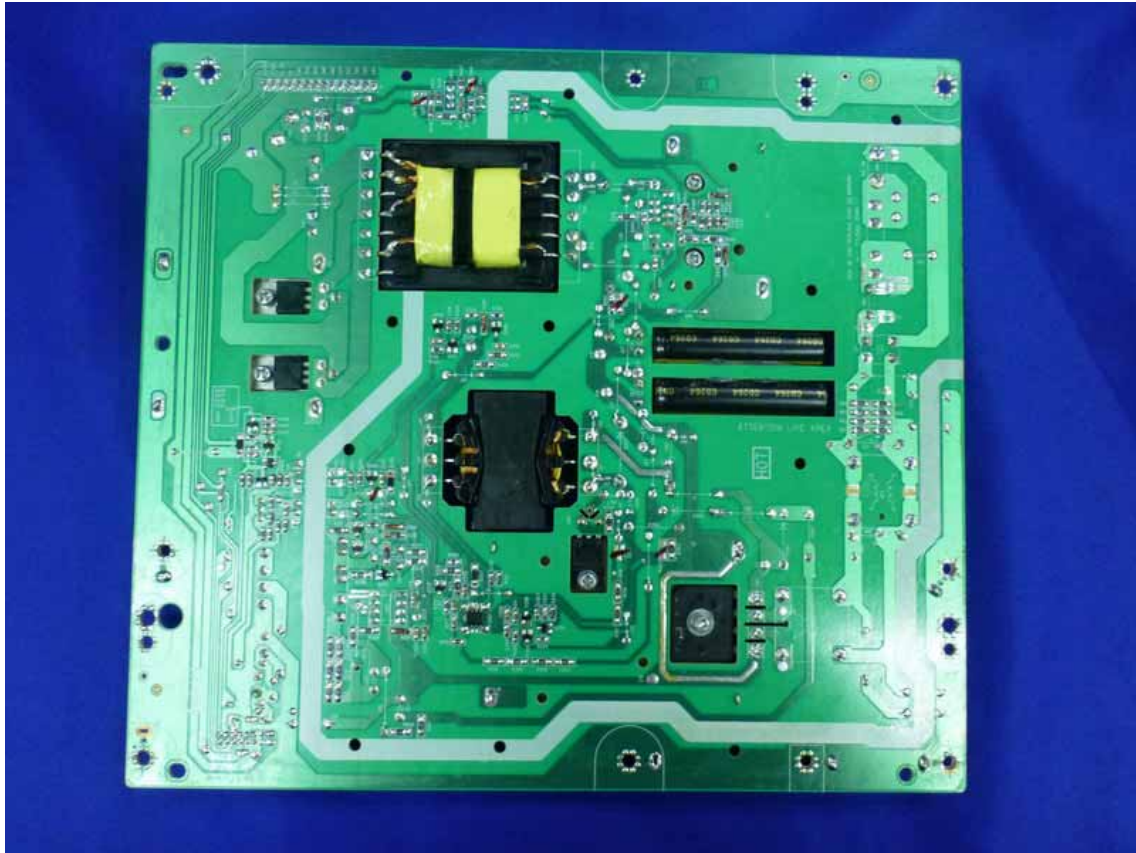

Figure 24
Frontside of the Power Board

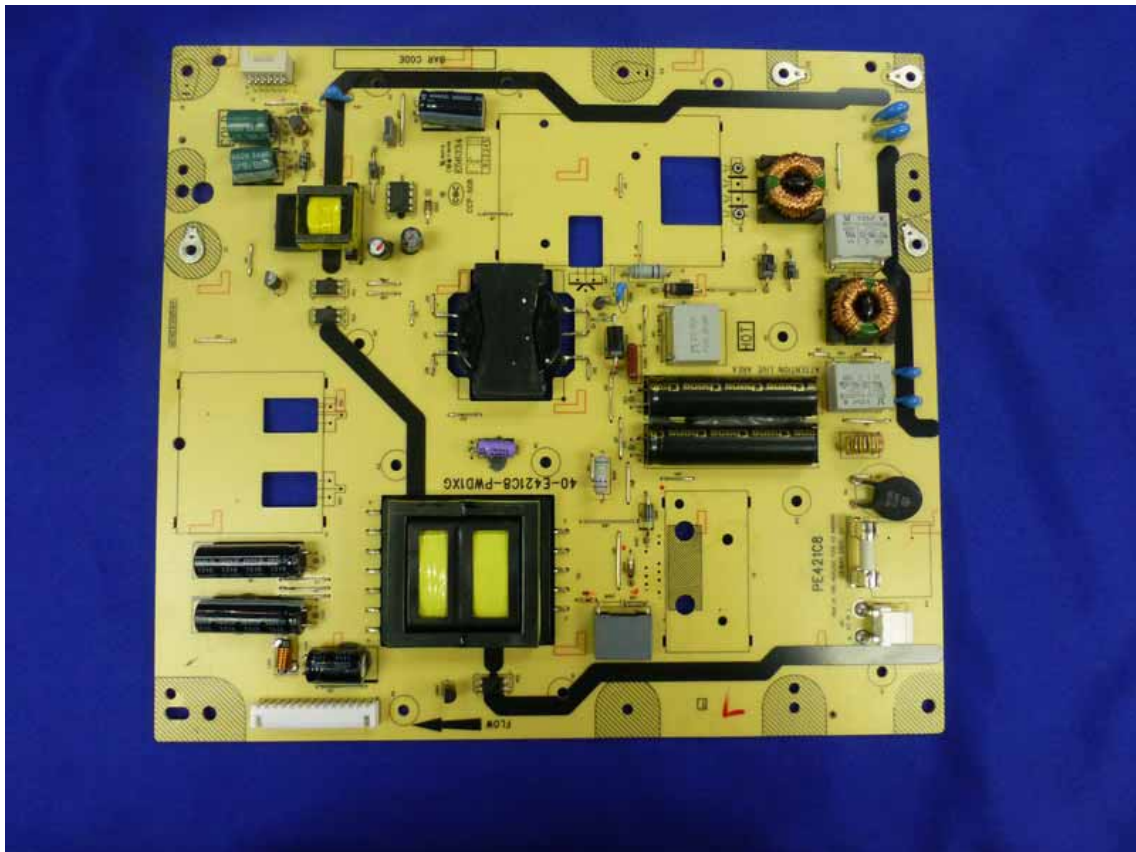

Figure 25
Frontside of the Power Board



Figure 26
Frontside of the PCB Board

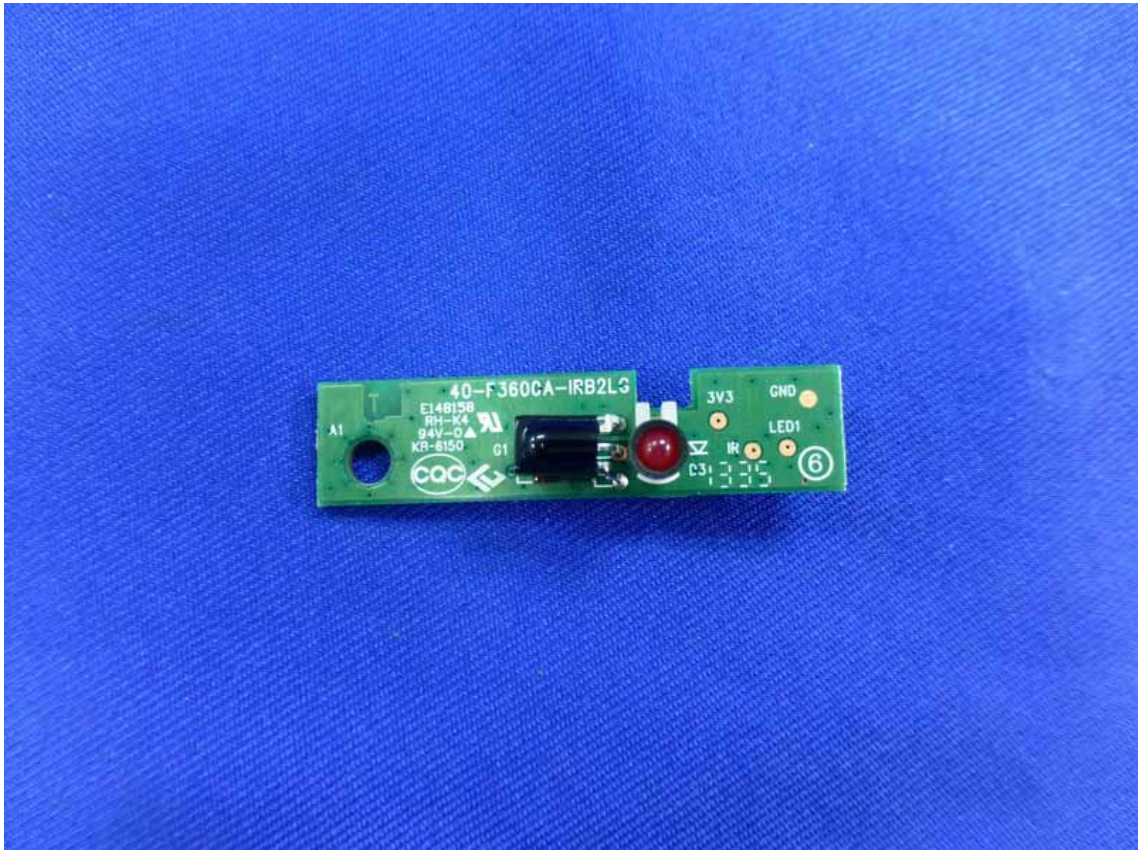

Figure 27
Backside of the PCB Board

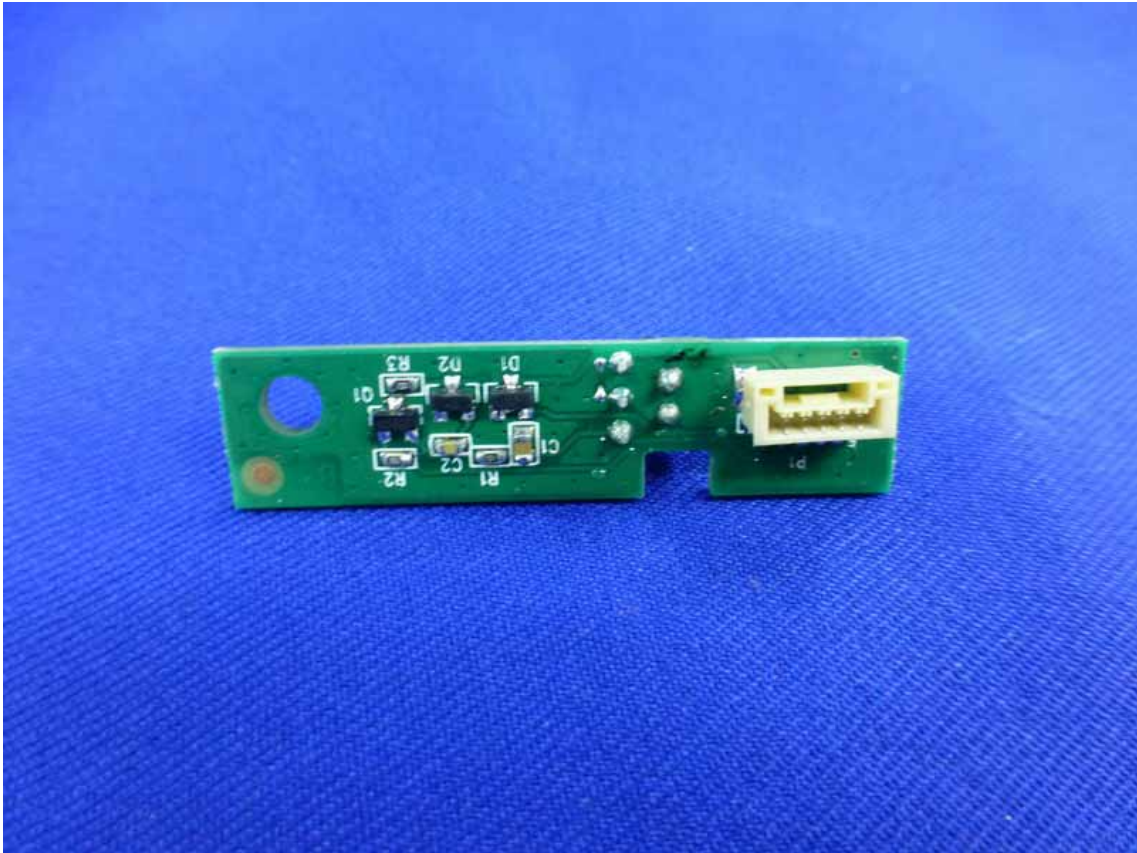

Figure 28
Frontside of the PCB Board



Figure 29
Backside of the PCB Board



Figure 30
TV Tuner



Figure 31
Speaker



Figure 32
Speaker

