



FCC ID:W8U48FS3750

APPLICATION OF CERTIFICATION

For

TTE Technology Inc.

LCD TV

Brand Name	Model Number
TCL	48FS3750; 48FS3700; 48FS3710; 48FS3790

FCC ID: W8U48FS3750

Prepared for : TTE Technology Inc.  
2455 Anselmo Drive, Suite 101, Corona, CA 92879

Prepared By: Audix Technology (Shenzhen) Co., Ltd.  
No. 6, Ke Feng Rd., 52 Block,  
Shenzhen Science & Industrial Park,  
Nantou, Shenzhen, Guangdong, China

Tel: (0755) 26639496  
Fax: (0755) 26632877

Report Number : ACS- F15176  
Date of Test : Jun.02~24, 2015  
Date of Report : Jul.02, 2015

**TABLE OF CONTENTS**

<b>Description</b>	<b>Page</b>
<b>Test Report Certification</b>	
<b>1. SUMMARY OF STANDARDS AND RESULTS .....</b>	<b>1-1</b>
1.1. Description of Standards and Results .....	1-1
<b>2. GENERAL INFORMATION.....</b>	<b>2-1</b>
2.1. Description of Device (EUT).....	2-1
2.2. Tested Supporting System Details .....	2-2
2.3. Block diagram of connection between the EUT and simulators.....	2-3
2.4. Test Facility .....	2-4
2.5. Measurement Uncertainty (95% confidence levels, k=2).....	2-4
<b>3. POWER LINE CONDUCTED EMISSION MEASUREMENT.....</b>	<b>3-1</b>
3.1. Test Equipment.....	3-1
3.2. Block Diagram of Test Setup.....	3-1
3.3. Power Line Conducted Emission Test Limits .....	3-1
3.4. Configuration of EUT on Test.....	3-2
3.5. Operating Condition of EUT .....	3-2
3.6. Test Procedure .....	3-2
3.7. Conducted Emission at Mains Terminals Test Results.....	3-3
<b>4. RADIATED EMISSION MEASUREMENT.....</b>	<b>4-1</b>
4.1. Test Equipment.....	4-1
4.2. Block Diagram of Test Setup.....	4-2
4.3. Radiated Emission Limit .....	4-3
4.4. EUT Configuration on Test .....	4-3
4.5. Operating Condition of EUT .....	4-3
4.6. Test Procedure .....	4-3
4.7. Radiated Emission Test Results.....	4-4
<b>5. DEVIATION TO TEST SPECIFICATIONS .....</b>	<b>5-1</b>
<b>6. PHOTOGRAPH .....</b>	<b>6-1</b>
6.1. Photos of Power Line Conducted Emission Test.....	6-1
6.2. Photos of Radiated Emission Test (In Anechoic Chamber) .....	6-2
<b>7. PHOTOS OF THE EUT .....</b>	<b>7-1</b>

FCC ID: W8U48FS3750

**TEST REPORT CERTIFICATION**

Applicant : TTE Technology Inc.  
 Manufacturer : TCL King Electrical Appliances (Huizhou) Co., Ltd.  
 EUT Description : LCD TV  
 FCC ID : W8U48FS3750  
 1. Model No. & : 

Brand Name	Model Number
TCL	48FS3750; 48FS3700; 48FS3710; 48FS3790

  
 Brand Name  
 (B) Power Supply : AC 120V/60Hz  
 (C) Test Voltage : AC 120V/60Hz

Measurement Standard Used:

FCC Rules and Regulations Part 15 Subpart B Class B 2014

The device described above is tested by AUDIX TECHNOLOGY (SHENZHEN) CO., LTD. to determine the maximum emission levels emanating from the device. The maximum emission levels are compared to the FCC Part 15 Subpart B Class B limits both conducted and radiated emissions. The test results are contained in this test report and AUDIX TECHNOLOGY (SHENZHEN) CO., LTD. is assumed of full responsibility for the accuracy and completeness of these tests. This report contains data that are not covered by the NVLAP accreditation.

After the test, our opinion is that EUT compliance with the requirement of the above standards.

This Report is made under FCC Part 2.1075. No modifications were required during testing to bring this product into compliance.

This report applies to above tested sample only. This report shall not be reproduced in parts without written approval of AUDIX TECHNOLOGY (SHENZHEN) CO., LTD.

The report must not be used by the client to claim product certification, approval, or endorsement by NVLAP, NIST, or any agency of the federal government.

Date of Test : Jun.02~24, 2015 Report of date: Jul.02, 2015Prepared by : Eva Yin / Assistant Reviewed by : Sun Zeng / Assistant ManagerApproved & Authorized Signer : David Jin / Manager

## 1. SUMMARY OF STANDARDS AND RESULTS

### 1.1. Description of Standards and Results

The EUT have been tested according to the applicable standards as referenced below.

EMISSION			
Description of Test Item	Standard	Results	Remarks
Power Line Conducted Emission Test	FCC Part 15: 2014 ANSI C63.4: 2009	PASS	Meets Class B Limit Minimum passing margin is 9.44 dB at 0.150 MHz
Radiated Emission Test (30-1000MHz)	FCC Part 15: 2014 ANSI C63.4: 2009	PASS	Meets Class B Limit Minimum passing margin is 3.78 dB at 742.68 MHz
Radiated Emission Test (1-18GHz)	FCC Part 15: 2014 ANSI C63.4: 2009	PASS	Meets Class B Limit Minimum passing margin is 8.30 dB at 2393.81MHz

## 2. GENERAL INFORMATION

### 2.1. Description of Device (EUT)

Description : LCD TV

Model Number& : Brand Name	Brand Name	Model Number
	TCL	48FS3750; 48FS3700; 48FS3710; 48FS3790

(All 48 " models are identical except for different appearance ( only for color, silk-screen and decorative parts) and model number for trading purpose.)

FCC ID : W8U48FS3750

Test Mode : 48FS3750

Applicant : TTE Technology Inc.  
2455 Anselmo Drive, Suite 101, Corona, CA 92879

Manufacturer : TCL King Electrical Appliances (Huizhou) Co., Ltd.  
Section 19, Zhongkai Development Zone for New and High Level  
TECH Industries, Huizhou, Guangdong 516006, P.R. China.

FREQUENCIES USED AND GENERATED WITHIN DEVICE	
LVDS (HD)	78MHZ
LVDS (FHD)	75MHZ
IF	6MHz
IC	800MHz

Internal photos of the EUT shows AC sockets line, FCC WIRE line, debug with the countermeasure scheme, these countermeasures and EUT production together.

Date of Test : Jun.02~24, 2015

Date of Receipt : May.30, 2015

Sample Type : Prototype production

2.2. Tested Supporting System Details

	Description	ACS No.	Manufacturer	Model	Serial Number	Approved type
1.	Personal Computer	Test PC S	DELL	Vostro 470	2SP05W1	<input checked="" type="checkbox"/> FCC DoC <input checked="" type="checkbox"/> BSMI ID:R33002
		Power Cord: Unshielded, Detachable, 1.8m Display Card: HD3450 (DVI+VGA+HDMI)				
2.	USB Keyboard	ACS-EMC- K04R	DELL	SK-8115	CN-ODJ313-71616 -6BB-049J	<input checked="" type="checkbox"/> FCC DoC <input checked="" type="checkbox"/> BSMI ID: T3A002
		Data Cable: shielded, Undetachable, 2.0m				
3.	Printer	ACS-EMC-PT04	HP	C9079A	N/A	<input checked="" type="checkbox"/> FCC DoC <input checked="" type="checkbox"/> BSMI ID: R33001
		USB Cable: Shielded, Detachable, 1.8m Power Cord: Unshielded, Detachable, 1.8m Power Adapter: HP, M/N: 0957-2119, BSMI ID: R33030, DC Cable: Unshielded, Detachable, 1.5m				
4.	USB Mouse	ACS-EMC-M04R	DELL	M056UO	512024282	<input checked="" type="checkbox"/> FCC DoC <input checked="" type="checkbox"/> BSMI ID: R41108
		Data Cable: shielded, Undetachable, 1.8m				
5.	iPod	ACS-EMC-IP01	APPLE	A1199	YM711H3LVQ5	<input checked="" type="checkbox"/> FCC DoC <input checked="" type="checkbox"/> BSMI ID: R33057
		Data Cable: Shielded, Detachable, 1.0m				
6.	HDD	ACS-EMC-HDD01	Terasys	F12-UF	A0100215-539001 8	<input checked="" type="checkbox"/> FCC DoC <input checked="" type="checkbox"/> BSMI ID: 4912A022
		USB Cable: Shielded, Detachable, 1.8m				
7.	Headphone	ACS-EMC-EP02	OVANN	OV880V	N/A	N/A
		USB Cable: Shielded, Detachable, 4.0m				
8.	Power Cable: Unshielded, Detachable, 1.8m HDMI Cable: Shielded, Detachable, 1.8m AV In: Unshielded, Detachable, 1.8m USB Cable: Unshielded, Detachable, 1.5m TV Cable: Unshielded, Detachable, 1.8m					

### 2.3. Block diagram of connection between the EUT and simulators

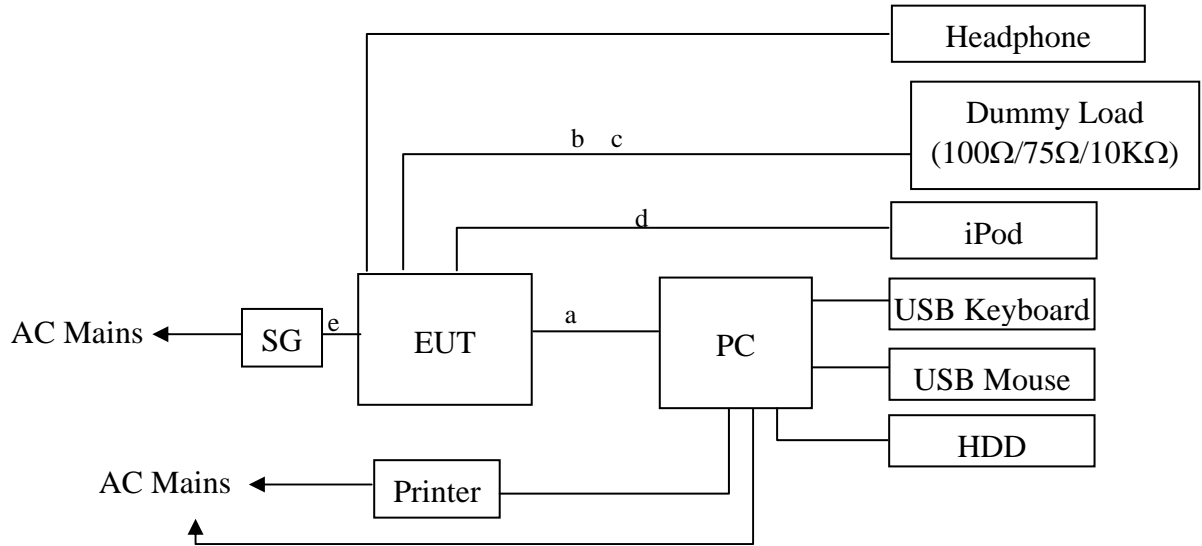

- a: HDMI Cable
- b: HDMI\*2 Cable
- c: AV In Cable
- d: USB Cable
- e: TV Cable

(EUT: LCD TV)

### 2.4. Test Facility

Site Description	
Name of Firm	: Audix Technology (Shenzhen) Co., Ltd. No. 6, Ke Feng Rd., 52 Block, Shenzhen Science & Industrial Park, Nantou, Shenzhen, Guangdong, China
3m Anechoic Chamber	: Certificated by FCC, USA Registration Number: 90454 Valid Date: Dec.30, 2017
3m & 10m Anechoic Chamber	: Certificated by FCC, USA Registration Number: 794232 Valid Date: Oct.31, 2015
EMC Lab.	: Accredited by DAkkS, Germany Registration No: D-PL-12151-01-00 Valid Date: Dec.15, 2016
	: Accredited by NVLAP, USA NVLAP Code: 200372-0 Valid Date: Mar.31, 2016

### 2.5. Measurement Uncertainty (95% confidence levels, k=2)

Test Item	Uncertainty
Uncertainty for Conduction emission test in No. 1 Conduction	3.1 dB(150kHz to 30MHz)
Uncertainty for Radiation Emission test in 3m chamber	3.3dB(30~200MHz, Polarize: H)
	3.3dB(30~200MHz, Polarize: V)
	3.5dB(200M~1GHz, Polarize: H)
	3.4dB(200M~1GHz, Polarize: V)
Uncertainty for Radiation Emission test in 3m chamber (1GHz-18GHz)	5.1dB(Distance: 3m, Polarize: V)
	5.3dB(Distance: 3m, Polarize: H)
Uncertainty for test site temperature and humidity	3%
	0.6°C



### 3. POWER LINE CONDUCTED EMISSION MEASUREMENT

#### 3.1. Test Equipment

Item	Equipment	Manufacturer	Model No.	Serial No.	Last Cal.	Cal. Interval
1.	1# Shielding Room	AUDIX	N/A	N/A	Apr.17,15	1 Year
2.	Test Receiver	Rohde & Schwarz	ESCI	100842	Apr.28,15	1 Year
3.	L.I.S.N.#1	Rohde & Schwarz	ESH2-Z5	100429	Oct.29,14	1 Year
4.	L.I.S.N.#3	Kyoritsu	KNW-242C	8-1920-1	Apr.28,15	1 Year
5.	Terminator	Hubersuhner	50Ω	No.1	Apr.28,15	1 Year
6.	Terminator	Hubersuhner	50Ω	No.2	Apr.28,15	1 Year
7.	RF Cable	MIYAZAKI	3D-2W	No.1	Apr.28,15	1 Year
8.	Coaxial Switch	Anritsu	MP59B	6200766906	Apr.28,15	1 Year
9.	Pulse Limiter	Rohde & Schwarz	ESH3-Z2	101838	Oct.29,14	1 Year
10.	MPEG2 Measurement Generator	ROHDE&SCHWARZ	DVG	100319	Oct.29,14	1 Year
11.	TV Transmitter	ROHDE&SCHWARZ	SFQ	100521	Apr.28,15	1 Year
12.	Signal Generator	HP	8648A	3625U00573	Apr.28,15	1 Year
13.	Pattern Generator	Philips	PM5418	LO625020	Apr.28,15	1 Year
14.	Test Software	AUDIX	E3	6.100913a	N/A	N/A

#### 3.2. Block Diagram of Test Setup

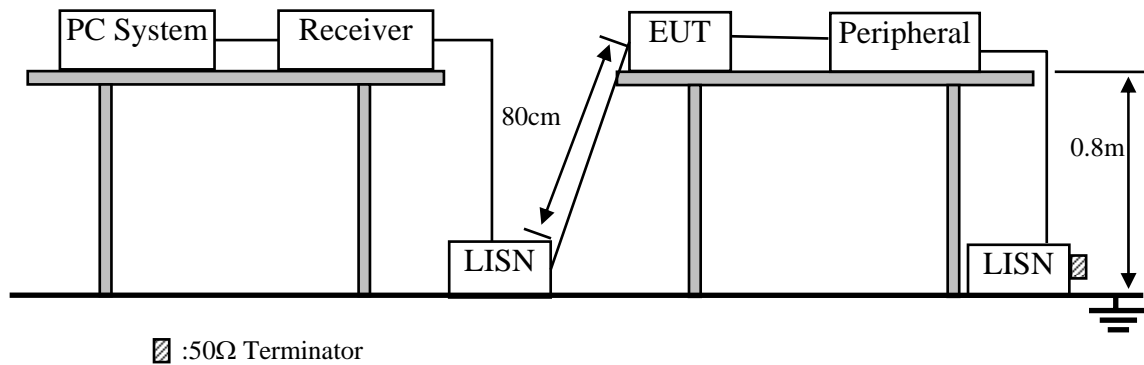

#### 3.3. Power Line Conducted Emission Test Limits

Frequency	Maximum RF Line Voltage	
	Quasi-Peak Level dB(μV)	Average Level dB(μV)
150kHz ~ 500kHz	66 ~ 56*	56 ~ 46*
500kHz ~ 5MHz	56	46
5MHz ~ 30MHz	60	50

Notes: 1. \* Decreasing linearly with logarithm of frequency.

2. The lower limit shall apply at the transition frequencies.

### 3.4. Configuration of EUT on Test

The following equipment are installed on Power Line Conducted Emission Test to meet the commission requirement and operating regulations in a manner which tends to maximize its emission characteristics in a normal application.

#### 3.4.1. LCD TV (EUT)

Model Number : 48FS3750  
Serial Number : N/A

3.4.2. Support Equipment : As Tested Supporting System Detail, in Section 2.2.

### 3.5. Operating Condition of EUT

3.5.1. Setup the EUT and simulator as shown as Section 3.2.

3.5.2. Turn on the power of all equipment.

3.5.3. PC system ran the Self-test program “EMC Test. exe” by windows XP and sent “H” Character to LCD TV (EUT) , the Screen of EUT displayed and filled with “H” pattern, use white letters on a black ground, set the contrast control to maximum, set the brightness control to maximum and measure it.

3.5.4. The other peripheral devices were driven and operated in turn during all testing.

### 3.6. Test Procedure

The EUT was placed on a non-metallic table, 80cm above the ground plane. The EUT Power connected to the power mains through a line impedance stabilization network (L.I.S.N. 1# ). This provided a 50-ohm coupling impedance for the EUT (Please refer to the block diagram of the test setup and photographs). The other peripheral devices power cord connected to the power mains through a line impedance stabilization network (L.I.S.N.# 3). Both sides of power line were checked for maximum conducted interference. In order to find the maximum emission, the relative positions of equipments and all of the interface cables were changed according to ANSI C63.4: 2009 on conducted Emission test.

The bandwidth of test receiver (R&S TEST RECEIVER ESCI) is set at 9kHz.

The frequency range from 150kHz to 30MHz is checked. The test result are reported on Section 3.7.

3.7. Conducted Emission at Mains Terminals Test Results

**PASS.** (All emissions not reported below are too low against the prescribed limits.)

The EUT with the following test modes were tested and selected to read Q.P values and average values, all the test results are listed in next pages.

EUT: LCD TV    Model No. : 48FS3750

Test Date: Jun.02, 2015    Temperature: 24.2°C    Humidity: 47%

The details of test modes are as follows :

The worst for video test mode					
No.	Test Mode	Input Port	Resolution & Frequency	Reference Test Data No.	
				Line	Neutral
<b>The Worst for Video Resolution of original report</b>					
1.	PC Mode	HDMI 1	1920*1080/60Hz	# 33	# 34
2. ※		HDMI 2	1920*1080/60Hz	# 31	# 32
3.		HDMI 3	1920*1080/60Hz	# 29	# 30
4.	TX Mode(WIFI)	---		# 35	# 36

(※ Worst test mode)

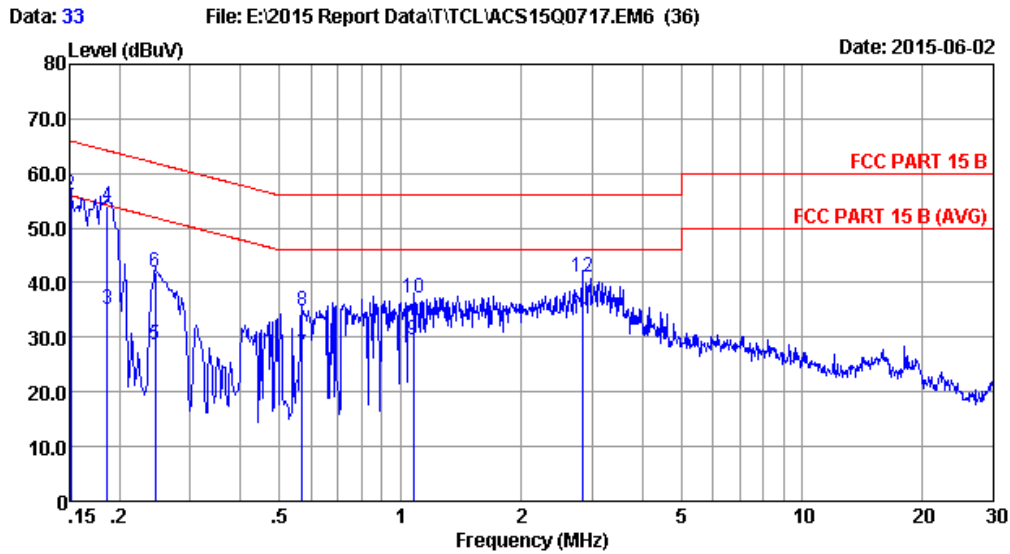

Site no :1# Conduction Data No :33  
 Dis./Lisn :2014 ESH2-25 LINE  
 Limit :FCC PART 15 B  
 Env./Ins. :24.2\*C/47% Engineer :Kevin\_He  
 EUT :LCD TV M/N:48FS3750  
 Power Rating :AC 120V/60Hz  
 Test Mode :Running "H" Pattern And 1kHz Playing  
 HDMI 1:1920\*1080@60Hz

No	Freq (MHz)	LISN Factor (dB)	Cable Loss (dB)	Reading (dBuV)	Emission Level (dBuV)	Limits (dBuV)	Margin (dB)	Remark
1	0.151	0.14	9.92	26.70	36.76	55.96	19.20	Average
2	0.151	0.14	9.92	46.12	56.18	65.96	9.78	QP
3	0.186	0.13	9.93	25.20	35.26	54.20	18.94	Average
4	0.186	0.13	9.93	44.06	54.12	64.20	10.08	QP
5	0.246	0.13	9.93	18.70	28.76	51.91	23.15	Average
6	0.246	0.13	9.93	31.76	41.82	61.91	20.09	QP
7	0.570	0.15	9.94	16.80	26.89	46.00	19.11	Average
8	0.570	0.15	9.94	24.81	34.90	56.00	21.10	QP
9	1.077	0.16	9.96	19.40	29.52	46.00	16.48	Average
10	1.077	0.16	9.96	27.08	37.20	56.00	18.80	QP
11	2.839	0.20	10.00	23.20	33.40	46.00	12.60	Average
12	2.839	0.20	10.00	30.97	41.17	56.00	14.83	QP

Remarks: 1.Emission Level=LISN Factor+Cable Loss(Include 10dB pulse limit)+Reading.  
 2.If the average limit is met when using a quasi-peak detector.  
 the EUT shall be deemed to meet both limits and measurement  
 with average detector is unnecessary.

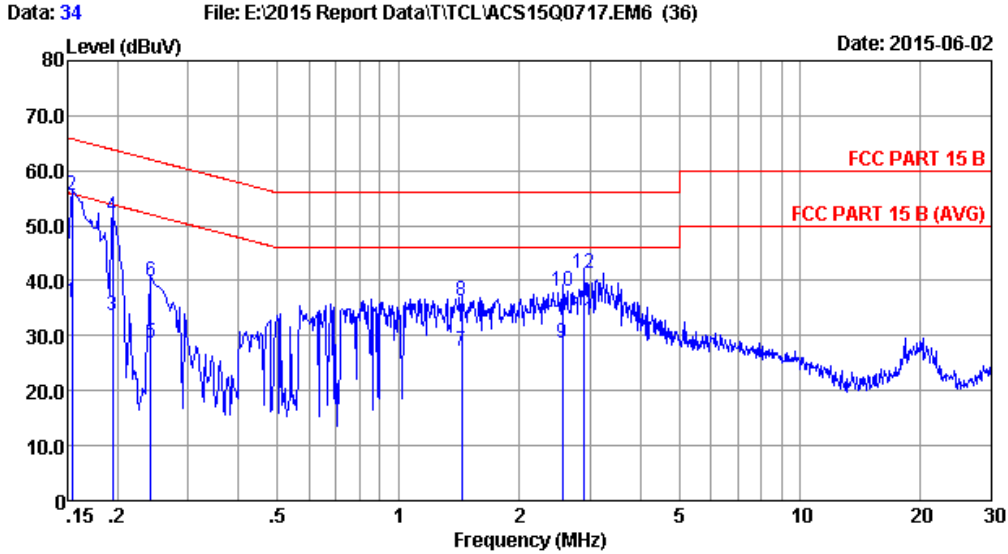

Site no :1# Conduction Data No :34  
 Dis./Lisn :2014 ESH2-25 NEUTRAL  
 Limit :FCC PART 15 B  
 Env./Ins. :24.2\*C/47% Engineer :Kevin\_He  
 EUT :LCD TV M/N:48FS3750  
 Power Rating :AC 120V/60Hz  
 Test Mode :Running "H" Pattern And 1kHz Playing  
 HDMI 1:1920\*1080@60Hz

No	Freq (MHz)	LISN Factor (dB)	Cable Loss (dB)	Reading (dBuV)	Emission Level (dBuV)	Limits (dBuV)	Margin (dB)	Remark
1	0.154	0.13	9.92	25.90	35.95	55.78	19.83	Average
2	0.154	0.13	9.92	45.33	55.38	65.78	10.40	QP
3	0.194	0.13	9.93	23.70	33.76	53.84	20.08	Average
4	0.194	0.13	9.93	41.46	51.52	63.84	12.32	QP
5	0.242	0.13	9.93	18.70	28.76	52.04	23.28	Average
6	0.242	0.13	9.93	29.65	39.71	62.04	22.33	QP
7	1.441	0.18	9.97	16.90	27.05	46.00	18.95	Average
8	1.441	0.18	9.97	26.03	36.18	56.00	19.82	QP
9	2.567	0.22	10.00	18.50	28.72	46.00	17.28	Average
10	2.567	0.22	10.00	27.91	38.13	56.00	17.87	QP
11	2.900	0.22	10.00	22.60	32.82	46.00	13.18	Average
12	2.900	0.22	10.00	31.09	41.31	56.00	14.69	QP

Remarks: 1.Emission Level=LISN Factor+Cable Loss(Include 10dB pulse limit)+Reading.  
 2.If the average limit is met when using a quasi-peak detector.  
 the EUT shall be deemed to meet both limits and measurement  
 with average detector is unnecessary.

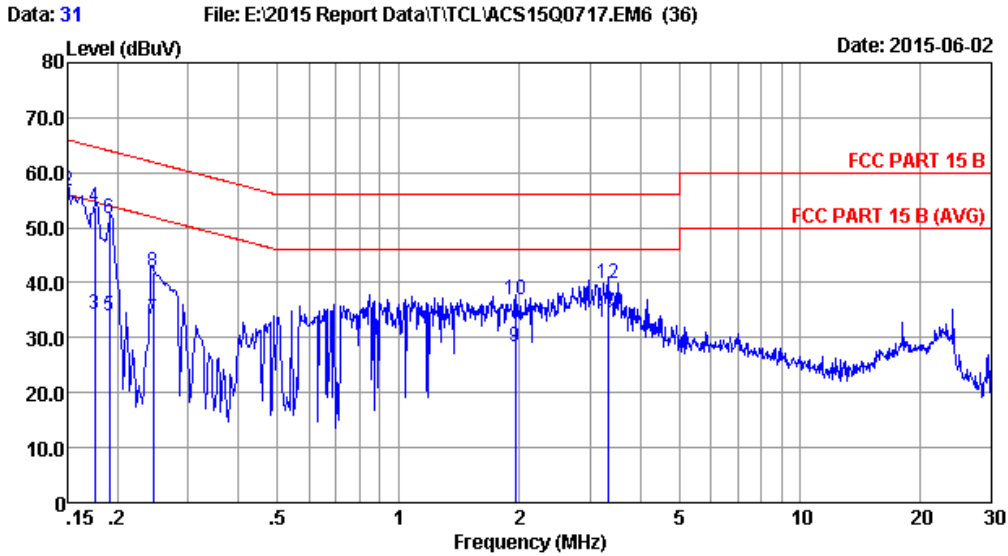

Site no :1# Conduction Data No :31  
 Dis./Lisn :2014 ESH2-25 LINE  
 Limit :FCC PART 15 B  
 Env./Ins. :24.2\*C/47% Engineer :Kevin\_He  
 EUT :LCD TV M/N:48FS3750  
 Power Rating :AC 120V/60Hz  
 Test Mode :Running "H" Pattern And 1kHz Playing  
 HDMI 2:1920\*1080@60Hz

No	Freq (MHz)	LISN Factor (dB)	Cable Loss (dB)	Reading (dBuV)	Emission Level (dBuV)	Limits (dBuV)	Margin (dB)	Remark
1	0.150	0.14	9.92	26.80	36.86	56.00	19.14	Average
2	0.150	0.14	9.92	46.50	56.56	66.00	9.44	QP
3	0.175	0.14	9.93	24.29	34.36	54.72	20.36	Average
4	0.175	0.14	9.93	43.66	53.73	64.72	10.99	QP
5	0.190	0.13	9.93	23.80	33.86	54.02	20.16	Average
6	0.190	0.13	9.93	41.49	51.55	64.02	12.47	QP
7	0.246	0.13	9.93	23.40	33.46	51.91	18.45	Average
8	0.246	0.13	9.93	31.95	42.01	61.91	19.90	QP
9	1.959	0.18	9.98	18.10	28.26	46.00	17.74	Average
10	1.959	0.18	9.98	26.77	36.93	56.00	19.07	QP
11	3.346	0.21	10.01	22.50	32.72	46.00	13.28	Average
12	3.346	0.21	10.01	29.70	39.92	56.00	16.08	QP

Remarks: 1.Emission Level=LISN Factor+Cable Loss(Include 10dB pulse limit)+Reading.  
 2.If the average limit is met when using a quasi-peak detector.  
 the EUT shall be deemed to meet both limits and measurement  
 with average detector is unnecessary.

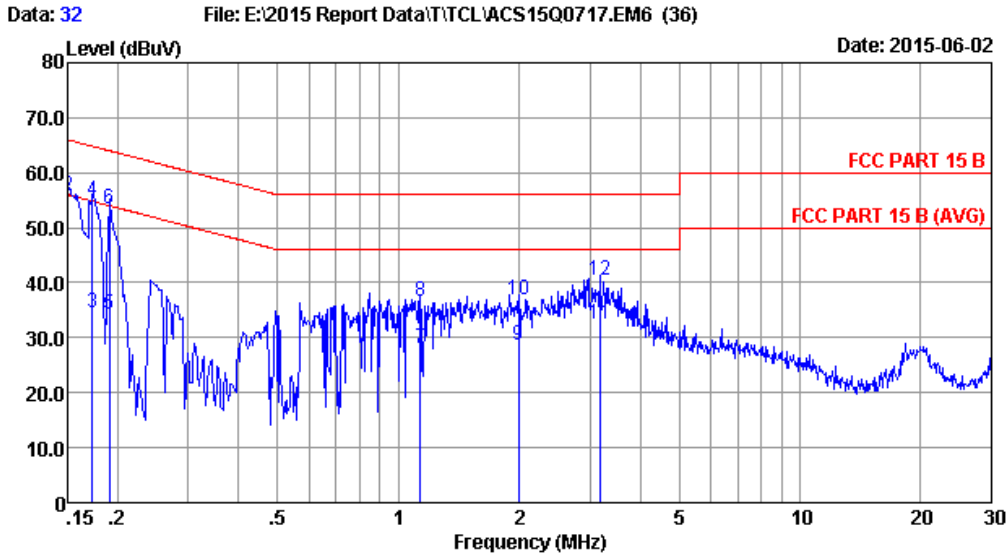

Site no :1# Conduction Data No :32  
 Dis./Lisn :2014 ESH2-25 NEUTRAL  
 Limit :FCC PART 15 B  
 Env./Ins. :24.2\*C/47% Engineer :Kevin\_He  
 EUT :LCD TV M/N:48FS3750  
 Power Rating :AC 120V/60Hz  
 Test Mode :Running "H" Pattern And 1kHz Playing  
 HDMI 2:1920\*1080@60Hz

No	Freq (MHz)	LISN Factor (dB)	Cable Loss (dB)	Reading (dBuV)	Emission Level (dBuV)	Limits (dBuV)	Margin (dB)	Remark
1	0.150	0.13	9.92	26.70	36.75	56.00	19.25	Average
2	0.150	0.13	9.92	45.60	55.65	66.00	10.35	QP
3	0.173	0.13	9.92	24.50	34.55	54.81	20.26	Average
4	0.173	0.13	9.92	45.00	55.05	64.81	9.76	QP
5	0.190	0.13	9.93	24.20	34.26	54.02	19.76	Average
6	0.190	0.13	9.93	43.27	53.33	64.02	10.69	QP
7	1.135	0.18	9.96	17.80	27.94	46.00	18.06	Average
8	1.135	0.18	9.96	26.55	36.69	56.00	19.31	QP
9	1.991	0.20	9.98	18.40	28.58	46.00	17.42	Average
10	1.991	0.20	9.98	26.75	36.93	56.00	19.07	QP
11	3.173	0.23	10.01	22.29	32.53	46.00	13.47	Average
12	3.173	0.23	10.01	30.19	40.43	56.00	15.57	QP

Remarks: 1.Emission Level=LISN Factor+Cable Loss(Include 10dB pulse limit)+Reading.  
 2.If the average limit is met when using a quasi-peak detector.  
 the EUT shall be deemed to meet both limits and measurement  
 with average detector is unnecessary.

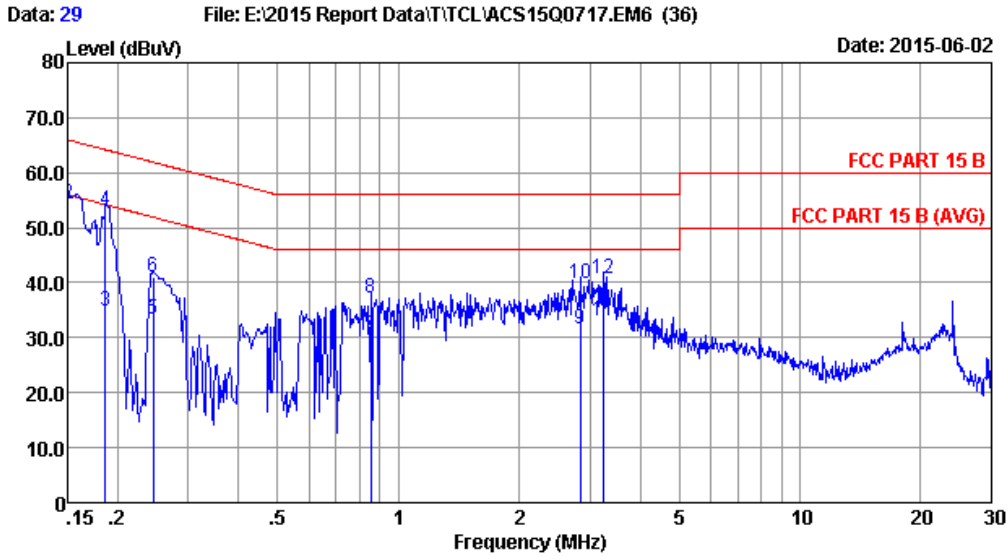

Site no :1# Conduction Data No :29  
 Dis./Lisn :2014 ESH2-25 LINE  
 Limit :FCC PART 15 B  
 Env./Ins. :24.2\*C/47% Engineer :Kevin\_He  
 EUT :LCD TV M/N:48FS3750  
 Power Rating :AC 120V/60Hz  
 Test Mode :Running "H" Pattern And 1kHz Playing  
 HDMI 3:1920\*1080@60Hz

No	Freq (MHz)	LISN Factor (dB)	Cable Loss (dB)	Reading (dBuV)	Emission Level (dBuV)	Limits (dBuV)	Margin (dB)	Remark
1	0.150	0.14	9.92	23.60	33.66	56.00	22.34	Average
2	0.150	0.14	9.92	44.25	54.31	66.00	11.69	QP
3	0.186	0.13	9.93	24.70	34.76	54.20	19.44	Average
4	0.186	0.13	9.93	43.19	53.25	64.20	10.95	QP
5	0.246	0.13	9.93	23.20	33.26	51.91	18.65	Average
6	0.246	0.13	9.93	31.01	41.07	61.91	20.84	QP
7	0.853	0.16	9.95	20.40	30.51	46.00	15.49	Average
8	0.853	0.16	9.95	27.22	37.33	56.00	18.67	QP
9	2.839	0.20	10.00	21.30	31.50	46.00	14.50	Average
10	2.839	0.20	10.00	29.69	39.89	56.00	16.11	QP
11	3.241	0.21	10.01	22.70	32.92	46.00	13.08	Average
12	3.241	0.21	10.01	30.63	40.85	56.00	15.15	QP

Remarks: 1.Emission Level=LISN Factor+Cable Loss(Include 10dB pulse limit)+Reading.  
 2.If the average limit is met when using a quasi-peak detector.  
 the EUT shall be deemed to meet both limits and measurement  
 with average detector is unnecessary.



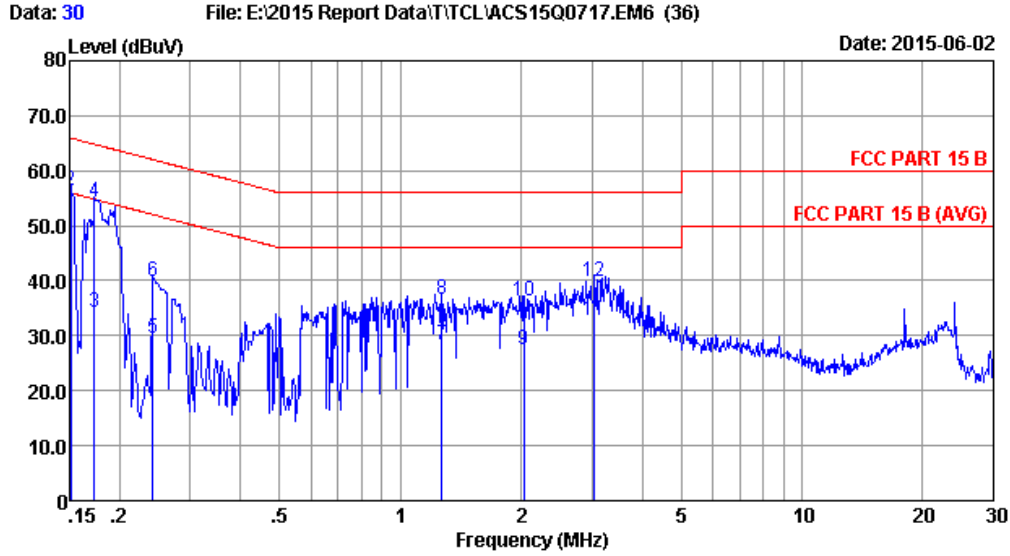

Site no :1# Conduction Data No :30  
 Dis./Lisn :2014 ESH2-25 NEUTRAL  
 Limit :FCC PART 15 B  
 Env./Ins. :24.2\*C/47% Engineer :Kevin\_He  
 EUT :LCD TV M/N:48FS3750  
 Power Rating :AC 120V/60Hz  
 Test Mode :Running "H" Pattern And 1kHz Playing  
 HDMI 3:1920\*1080@60Hz

No	Freq (MHz)	LISN Factor (dB)	Cable Loss (dB)	Reading (dBuV)	Emission Level (dBuV)	Limits (dBuV)	Margin (dB)	Remark
1	0.151	0.13	9.92	25.80	35.85	55.96	20.11	Average
2	0.151	0.13	9.92	46.30	56.35	65.96	9.61	QP
3	0.173	0.13	9.92	24.10	34.15	54.81	20.66	Average
4	0.173	0.13	9.92	44.20	54.25	64.81	10.56	QP
5	0.242	0.13	9.93	19.40	29.46	52.04	22.58	Average
6	0.242	0.13	9.93	29.73	39.79	62.04	22.25	QP
7	1.269	0.18	9.96	18.20	28.34	46.00	17.66	Average
8	1.269	0.18	9.96	26.60	36.74	56.00	19.26	QP
9	2.033	0.20	9.99	17.30	27.49	46.00	18.51	Average
10	2.033	0.20	9.99	26.12	36.31	56.00	19.69	QP
11	3.041	0.22	10.00	22.61	32.83	46.00	13.17	Average
12	3.041	0.22	10.00	29.71	39.93	56.00	16.07	QP

Remarks: 1.Emission Level=LISN Factor+Cable Loss(Include 10dB pulse limit)+Reading.  
 2.If the average limit is met when using a quasi-peak detector.  
 the EUT shall be deemed to meet both limits and measurement  
 with average detector is unnecessary.

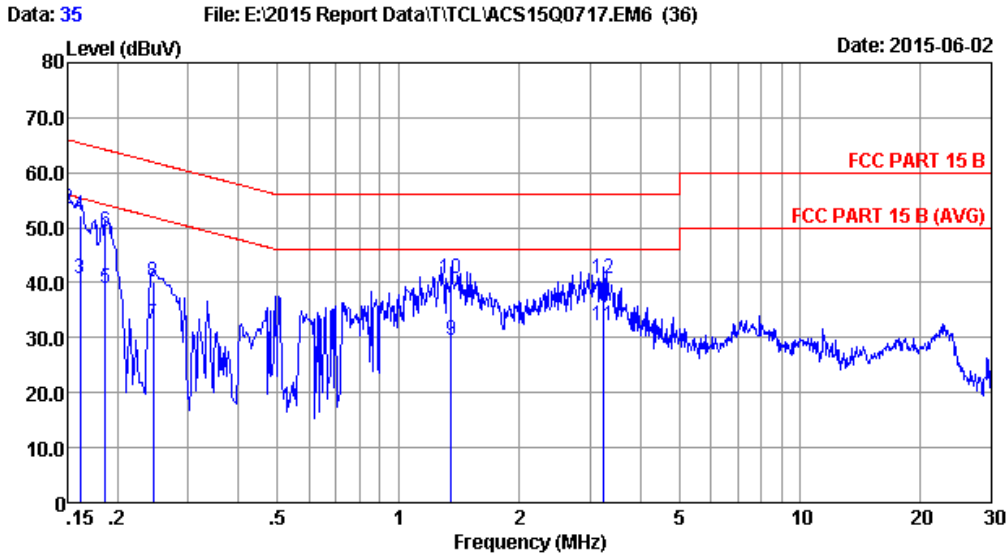

Site no :1# Conduction Data No :35  
 Dis./Lisn :2014 ESH2-25 LINE  
 Limit :FCC PART 15 B  
 Env./Ins. :24.2\*C/47% Engineer :Kevin\_He  
 EUT :LCD TV M/N:48FS3750  
 Power Rating :AC 120V/60Hz  
 Test Mode :TX Mode(WIFI)

No	Freq (MHz)	LISN Factor (dB)	Cable Loss (dB)	Reading (dBuV)	Emission Level (dBuV)	Limits (dBuV)	Margin (dB)	Remark
1	0.150	0.14	9.92	31.80	41.86	56.00	14.14	Average
2	0.150	0.14	9.92	43.25	53.31	66.00	12.69	QP
3	0.162	0.14	9.92	30.60	40.66	55.38	14.72	Average
4	0.162	0.14	9.92	42.22	52.28	65.38	13.10	QP
5	0.186	0.13	9.93	28.80	38.86	54.20	15.34	Average
6	0.186	0.13	9.93	39.19	49.25	64.20	14.95	QP
7	0.246	0.13	9.93	22.50	32.56	51.91	19.35	Average
8	0.246	0.13	9.93	30.01	40.07	61.91	21.84	QP
9	1.352	0.17	9.96	19.50	29.63	46.00	16.37	Average
10	1.352	0.17	9.96	30.67	40.80	56.00	15.20	QP
11	3.241	0.21	10.01	21.90	32.12	46.00	13.88	Average
12	3.241	0.21	10.01	30.63	40.85	56.00	15.15	QP

Remarks: 1.Emission Level=LISN Factor+Cable Loss(Include 10dB pulse limit)+Reading.  
 2.If the average limit is met when using a quasi-peak detector.  
 the EUT shall be deemed to meet both limits and measurement  
 with average detector is unnecessary.

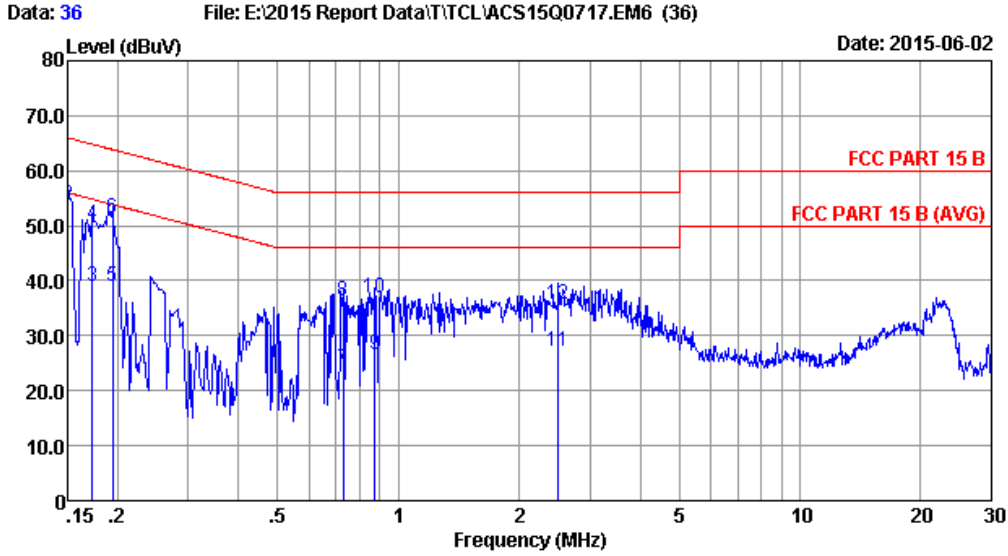

Site no :1# Conduction Data No :36  
 Dis./Lisn :2014 ESH2-25 NEUTRAL  
 Limit :FCC PART 15 B  
 Env./Ins. :24.2\*C/47% Engineer :Kevin\_He  
 EUT :LCD TV M/N:48FS3750  
 Power Rating :AC 120V/60Hz  
 Test Mode :TX Mode(WIFI)

No	Freq (MHz)	LISN Factor (dB)	Cable Loss (dB)	Reading (dBuV)	Emission Level (dBuV)	Limits (dBuV)	Margin (dB)	Remark
1	0.150	0.13	9.92	30.90	40.95	56.00	15.05	Average
2	0.150	0.13	9.92	43.56	53.61	66.00	12.39	QP
3	0.173	0.13	9.92	28.80	38.85	54.81	15.96	Average
4	0.173	0.13	9.92	40.20	50.25	64.81	14.56	QP
5	0.194	0.13	9.93	28.79	38.85	53.84	14.99	Average
6	0.194	0.13	9.93	41.25	51.31	63.84	12.53	QP
7	0.727	0.16	9.95	13.90	24.01	46.00	21.99	Average
8	0.727	0.16	9.95	26.27	36.38	56.00	19.62	QP
9	0.876	0.18	9.95	16.40	26.53	46.00	19.47	Average
10	0.876	0.18	9.95	26.68	36.81	56.00	19.19	QP
11	2.500	0.22	10.00	16.80	27.02	46.00	18.98	Average
12	2.500	0.22	10.00	25.45	35.67	56.00	20.33	QP

Remarks: 1.Emission Level=LISN Factor+Cable Loss(Include 10dB pulse limit)+Reading.  
 2.If the average limit is met when using a quasi-peak detector.  
 the EUT shall be deemed to meet both limits and measurement  
 with average detector is unnecessary.

## 4. RADIATED EMISSION MEASUREMENT

### 4.1. Test Equipment

#### 4.1.1. For frequency range 30MHz~1000MHz

Item	Equipment	Manufacturer	Model No.	Serial No.	Last Cal.	Cal. Interval
1.	3#Chamber	AUDIX	N/A	N/A	Nov.23,14	1 Year
2.	EMI Spectrum	Agilent	E4407B	MY41440292	Apr.28,15	1 Year
3.	Test Receiver	Rohde & Schwarz	ESVS10	834468/011	Apr.28,15	1 Year
4.	Amplifier	HP	8447D	2648A04738	Apr.28,15	1 Year
5.	Trilog-Broadband Antenna	SCHWARZBECK	VULB 9168	9168-493	May.06,15	1 Year
6.	RF Cable	MIYAZAKI	CFD400-N W(3.5M)	3# Chamber No.3	Apr.28,15	1 Year
7.	RF Cable	MIYAZAKI	CFD400-L W(22M)	3# Chamber No.7	Apr.28,15	1 Year
8.	Coaxial Switch	Anritsu	MP59B	6201397222	Apr.28,15	1 Year
9.	MPEG2 Measurement Generator	ROHDE&SCHWARZ	DVG	100319	Oct.29,14	1 Year
10.	TV Transmitter	ROHDE&SCHWARZ	SFQ	100521	Apr.28,15	1 Year
11.	Signal Generator	HP	8648A	3625U00573	Apr.28,15	1 Year
12.	Pattern Generator	Philips	PM5418	LO625020	Apr.28,15	1 Year
13.	Test Software	AUDIX	E3	6.2009-5-21a(n)	N/A	N/A

#### 4.1.2. For frequency range 1GHz~18GHz

Item	Equipment	Manufacturer	Model No.	Serial No.	Last Cal.	Cal. Interval
1.	3#Chamber	AUDIX	N/A	N/A	Nov.02,14	1 Year
2.	Spectrum Analyzer	Agilent	E4407B	MY41440292	Apr.28,15	1 Year
3.	Horn Antenna	ETC	MCTD 1209	DRH15F03006	Feb.03,15	1 Year
4.	Horn Antenna	ETS	3115	9510-4877	Sep.20,14	1 Year
5.	Amplifier	Agilent	83017A	MY53270084	May.25,15	1 Year
6.	RF Cable	Hubersuhner	SUCOFLEX106	505238/6+2861 6/2	Apr.28,15	1 Year
7.	MPEG2 Measurement Generator	ROHDE&SCHWARZ	DVG	100319	Oct.29,14	1 Year
8.	TV Transmitter	ROHDE&SCHWARZ	SFQ	100521	Apr.28,15	1 Year
9.	Pattern Generator	Philips	PM5418	LO625020	Apr.28,15	1 Year
10.	Test Software	AUDIX	E3	6.2009-5-21a(n)	N/A	N/A

### 4.2. Block Diagram of Test Setup

#### 4.2.1. For frequency range 30MHz-1000MHz

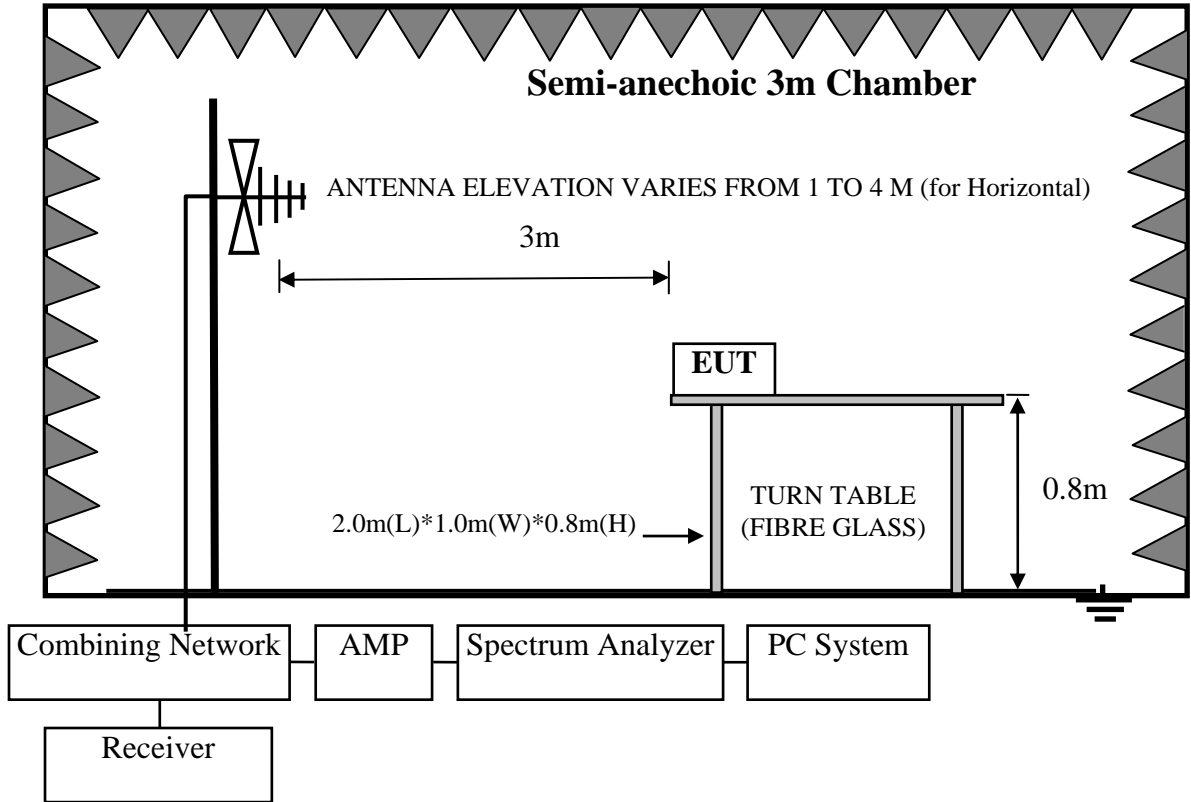

#### 4.2.2. For frequency range 1GHz-18GHz

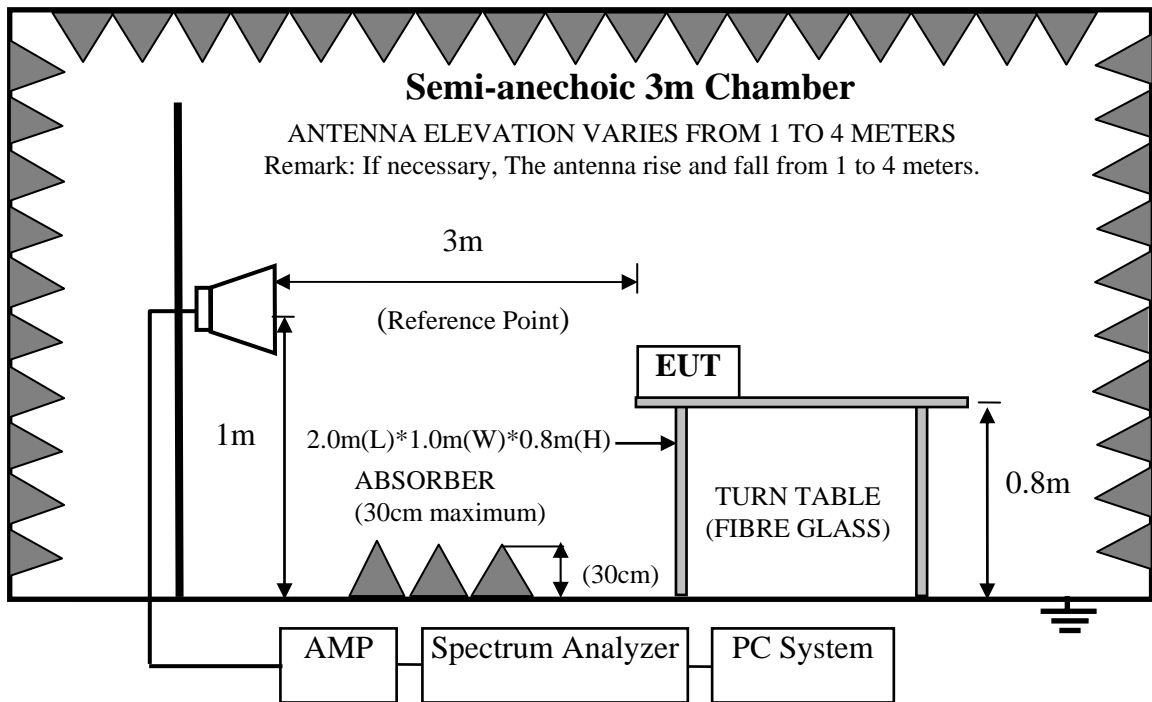

#### 4.3. Radiated Emission Limit

Frequency MHz	Distance (Meters)	Field Strengths Limits dB( $\mu$ V)/m
30 ~ 88	3	40.0
88 ~ 216	3	43.5
216 ~ 960	3	46.0
960 ~ 1000	3	54.0
Above 1000	3	74(Peak)54(Average)

- Remark: (1) Emission level = Antenna Factor + Cable Loss + Reading  
Emission level = Antenna Factor - Amp Factor + Cable Loss + Reading  
(above 1000MHz)
- (2) The smaller limit shall apply at the cross point between two frequency bands.
- (3) Distance is the distance in meters between the measuring instrument, antenna and the closest point of any part of the device or system.

#### 4.4. EUT Configuration on Test

The configurations of EUT are listed in Section 3.4

#### 4.5. Operating Condition of EUT

Same as Conducted Emission test that is listed in Section 3.5. except the test set up replaced by Section 4.2.

#### 4.6. Test Procedure

The EUT was placed on a non-metallic table, 80 cm above the ground plane inside a semi-anechoic chamber. An antenna was located 3m from the EUT on an adjustable mast. A pre-scan was first performed in order to find prominent radiated emissions. For final emissions measurements at each frequency of interest, the EUT were rotated and the antenna height was varied between 1m and 4m in order to maximize the emission. Measurements in both horizontal and vertical polarities were made and the data was recorded. In order to find the maximum emission, the relative positions of equipments and all of the interface cables were changed according to ANSI C63.4: 2009 on Radiated Emission test.

The bandwidth of the EMI test receiver (R&S ESVS10) is set at 120kHz for frequency range from 30MHz to 1000 MHz.

The bandwidth of the Spectrum's RBW is set at 1MHz and VBW is set at 3MHz for peak emissions measurement above 1GHz and 1MHz RBW, 10Hz VBW for average emissions measure above 1GHz.

4.7. Radiated Emission Test Results

**PASS.** (All emissions not reported below are too low against the prescribed limits.)

EUT: LCD TV

Model No. : 48FS3750

**For frequency range 30MHz~1000MHz**

The EUT with the following test modes were tested and selected to read Q.P values, all the test results are listed in next pages.

Test Date: Jun.24, 2015

Temperature: 24°C

Humidity: 56%

The details of test modes are as follows :

The worst for video test mode					
No.	Test Mode	Input Port	Resolution & Frequency	Reference Test Data No.	
				Horizontal	Vertical
<b>The Worst for Video Resolution of original report</b>					
1.	PC Mode	HDMI 1	1920*1080/60Hz	# 43	# 44
2.		HDMI 2	1920*1080/60Hz	# 46	# 45
3. ※		HDMI 3	1920*1080/60Hz	# 47	# 48
4.	TX Mode(WIFI)	---		# 50	# 49

(※ Worst test mode)

**For frequency range 1GHz~18GHz**

The EUT with below test mode were measured within Anechoic Chamber and the test results listed in next pages

Note: For all the emissions above 1GHz, the peak measured level comply with peak limit, so the average level were deemed to comply with average limit.

Test Date: Jun.24, 2015

Temperature: 24°C

Humidity: 56%

The worst for video test mode					
No.	Test Mode	Input Port	Resolution & Frequency	Reference Test Data No.	
				Horizontal	Vertical
<b>The Worst for Video Resolution of original report</b>					
1.	PC Mode	HDMI 1	1920*1080/60Hz	# 36	# 35
2.		HDMI 2	1920*1080/60Hz	# 37	# 38
3. ※		HDMI 3	1920*1080/60Hz	# 40	# 39
4.	TX Mode(WIFI)	---		# 41	# 42

(※ Worst test mode)

30MHz~1000MHz

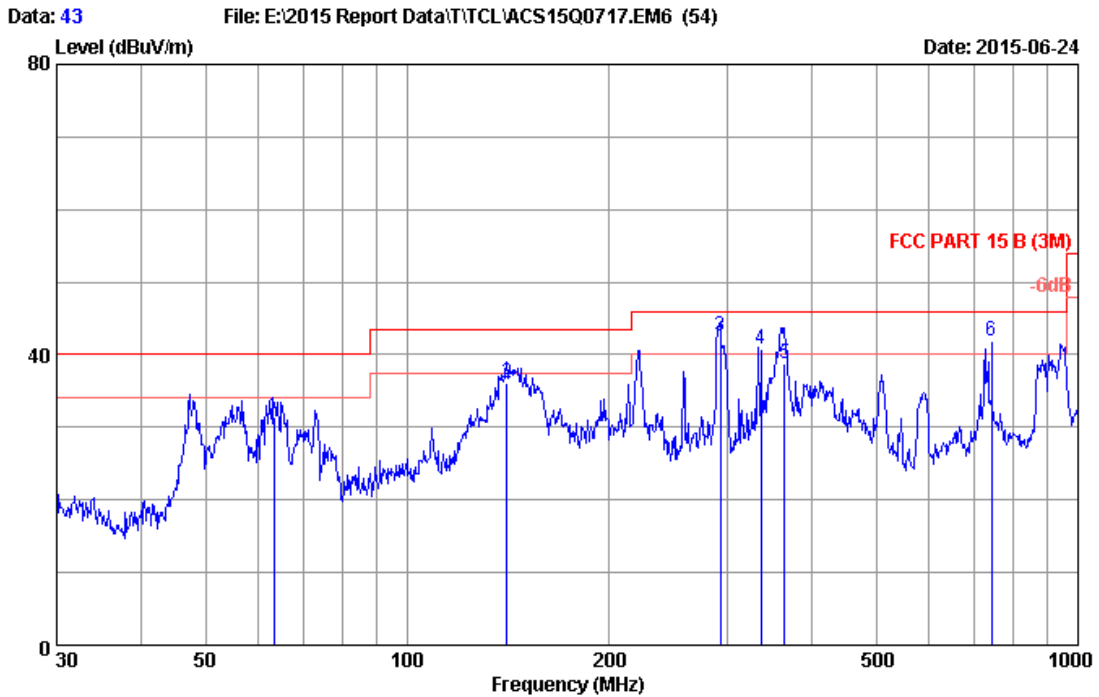

Site no. : 3m Chamber Data no. : 43  
 Dis. / Ant. : 3m 2015 VULB 9168-493 Ant. pol. : HORIZONTAL  
 Limit : FCC PART 15 B (3M)  
 Env. / Ins. : 24°C/56% Engineer : Even\_Deng  
 EUT : LCD TV M/N:48FS3750  
 Power rating : AC 120V/60Hz  
 Test Mode : Running "H" Pattern And 1KHz Playing  
 HDMI 1:1920\*1080@60Hz

No.	Freq. (MHz)	Ant. Factor (dB/m)	Cable Loss (dB)	Reading (dBuV)	Emission Level (dBuV/m)	Limits (dBuV/m)	Margin (dB)	Remark
1	63.31	12.86	0.89	17.68	31.43	40.00	8.57	QP
2	140.84	14.03	1.27	20.72	36.02	43.50	7.48	QP
3	293.08	13.93	1.87	26.78	42.58	46.00	3.42	QP
4	336.28	14.83	2.01	23.99	40.83	46.00	5.17	QP
5	365.50	15.54	2.10	21.07	38.71	46.00	7.29	QP
6	742.81	21.83	3.12	16.91	41.86	46.00	4.14	QP

Remarks: 1. Emission Level= Antenna Factor + Cable Loss + Reading.  
 2. The emission levels that are 20dB below the official limit are not reported.



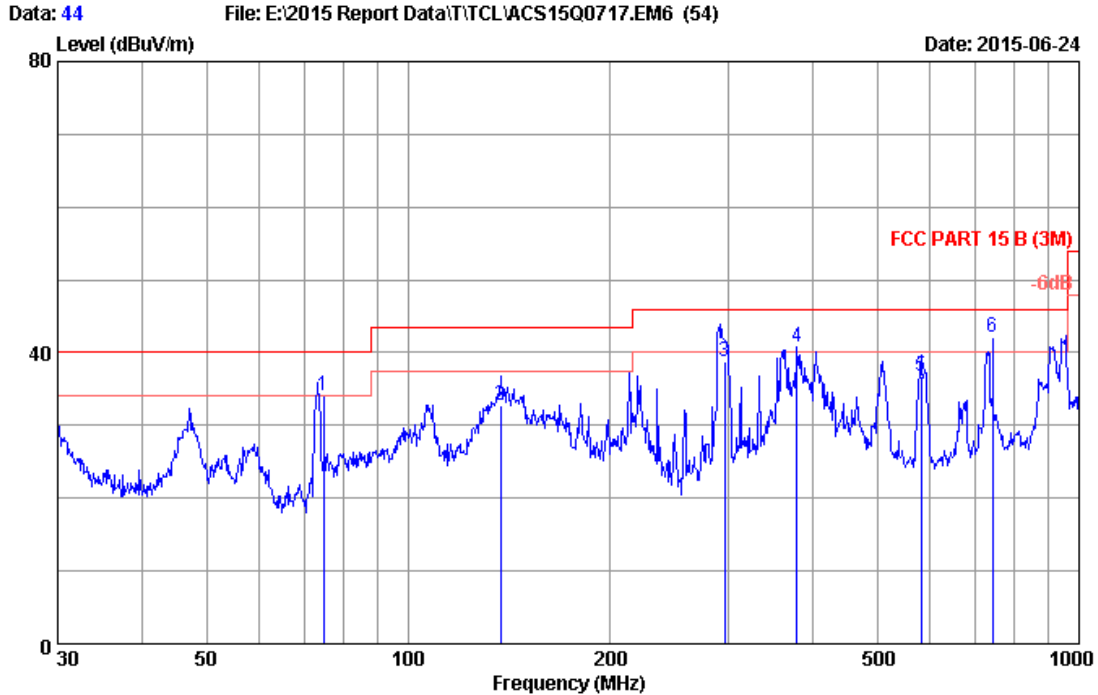

Site no. : 3m Chamber Data no. : 44  
 Dis. / Ant. : 3m 2015 VULB 9168-493 Ant. pol. : VERTICAL  
 Limit : FCC PART 15 B (3M)  
 Env. / Ins. : 24°C/56% Engineer : Even\_Deng  
 EUT : LCD TV M/N:48FS3750  
 Power rating : AC 120V/60Hz  
 Test Mode : Running"H"Pattern And 1KHz Playing  
 HDMI 1:1920\*1080@60Hz

No.	Freq. (MHz)	Ant. Factor (dB/m)	Cable Loss (dB)	Reading (dBuV)	Emission Level (dBuV/m)	Limits (dBuV/m)	Margin (dB)	Remark
1	74.75	10.69	0.98	22.32	33.99	40.00	6.01	QP
2	137.42	13.86	1.27	17.63	32.76	43.50	10.74	QP
3	296.20	14.00	1.87	22.90	38.77	46.00	7.23	QP
4	379.91	15.95	2.14	22.76	40.85	46.00	5.15	QP
5	580.70	19.65	2.72	14.37	36.74	46.00	9.26	QP
6	742.92	21.83	3.12	17.11	42.06	46.00	3.94	QP

Remarks: 1. Emission Level= Antenna Factor + Cable Loss + Reading.  
 2. The emission levels that are 20dB below the official limit are not reported.

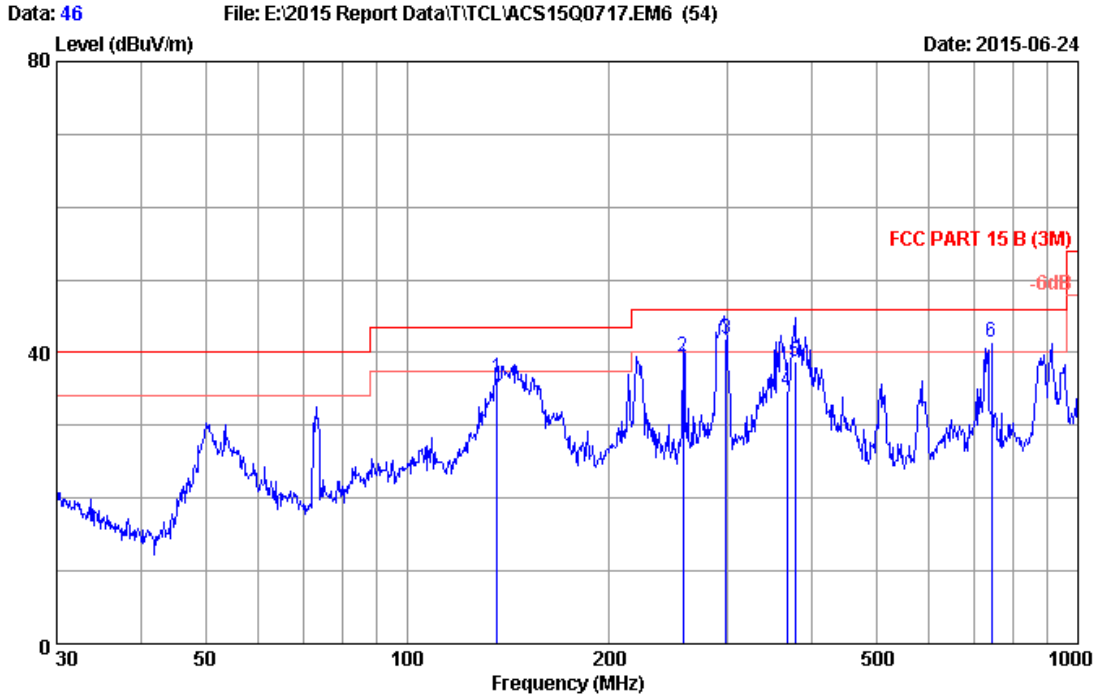

Site no. : 3m Chamber Data no. : 46  
 Dis. / Ant. : 3m 2015 VULB 9168-493 Ant. pol. : HORIZONTAL  
 Limit : FCC PART 15 B (3M)  
 Env. / Ins. : 24°C/56% Engineer : Even\_Deng  
 EUT : LCD TV M/N:48FS3750  
 Power rating : AC 120V/60Hz  
 Test Mode : Running"H"Pattern And 1KHz Playing  
 HDMI 2:1920\*1080@60Hz

No.	Freq. (MHz)	Ant. Factor (dB/m)	Cable Loss (dB)	Reading (dBuV)	Emission Level (dBuV/m)	Limits (dBuV/m)	Margin (dB)	Remark
1	135.98	13.72	1.24	21.61	36.57	43.50	6.93	QP
2	257.42	12.37	1.73	25.44	39.54	46.00	6.46	QP
3	298.88	14.08	1.90	25.86	41.84	46.00	4.16	QP
4	367.68	15.59	2.12	17.06	34.77	46.00	11.23	QP
5	378.58	15.90	2.14	20.77	38.81	46.00	7.19	QP
6	742.81	21.83	3.12	16.54	41.49	46.00	4.51	QP

Remarks: 1. Emission Level= Antenna Factor + Cable Loss + Reading.  
 2. The emission levels that are 20dB below the official limit are not reported.

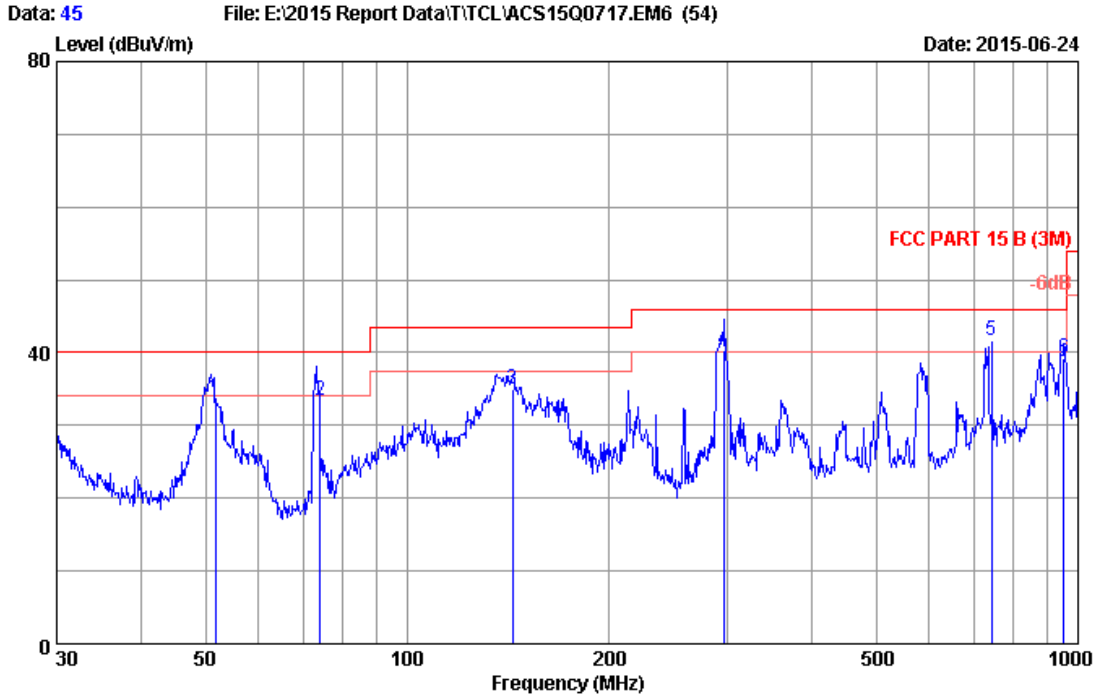

Site no. : 3m Chamber Data no. : 45  
 Dis. / Ant. : 3m 2015 VULB 9168-493 Ant. pol. : VERTICAL  
 Limit : FCC PART 15 B (3M)  
 Env. / Ins. : 24°C/56% Engineer : Even\_Deng  
 EUT : LCD TV M/N:48FS3750  
 Power rating : AC 120V/60Hz  
 Test Mode : Running"H"Pattern And 1KHz Playing  
 HDMI 2:1920\*1080@60Hz

No.	Freq. (MHz)	Ant. Factor (dB/m)	Cable Loss (dB)	Reading (dBuV)	Emission Level (dBuV/m)	Limits (dBuV/m)	Margin (dB)	Remark
1	51.80	14.30	0.81	18.84	33.95	40.00	6.05	QP
2	74.13	10.87	0.98	21.55	33.40	40.00	6.60	QP
3	143.33	14.11	1.27	19.65	35.03	43.50	8.47	QP
4	295.81	14.00	1.87	24.39	40.26	46.00	5.74	QP
5	742.49	21.83	3.12	16.74	41.69	46.00	4.31	QP
6	952.09	24.23	3.61	11.43	39.27	46.00	6.73	QP

Remarks: 1. Emission Level= Antenna Factor + Cable Loss + Reading.  
 2. The emission levels that are 20dB below the official limit are not reported.

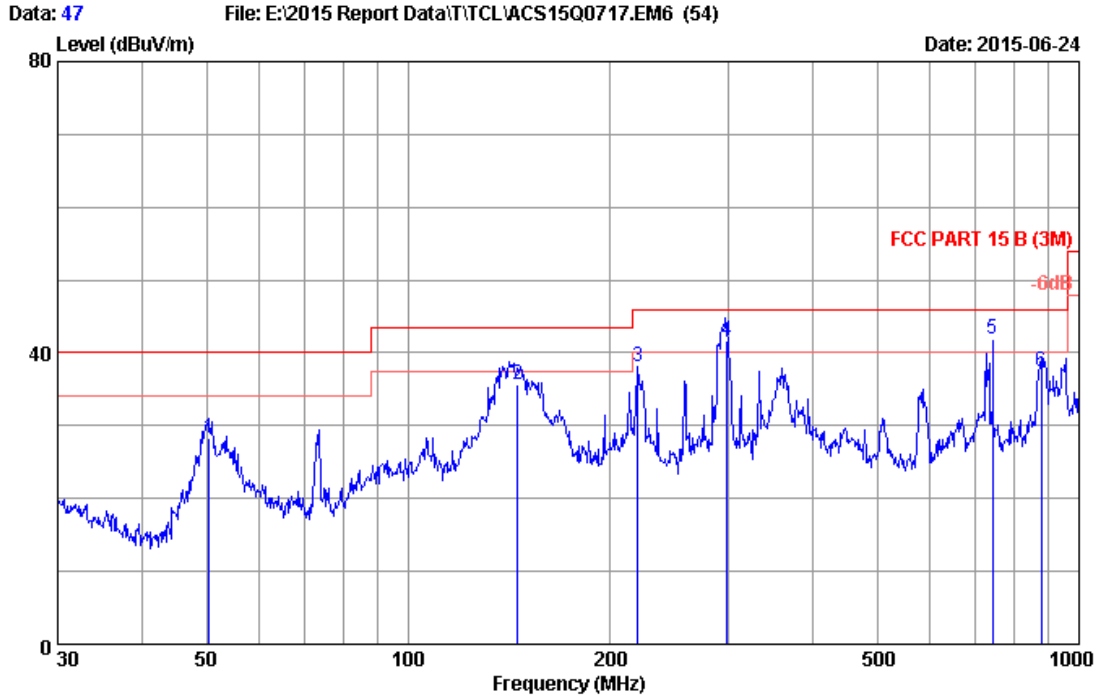

Site no. : 3m Chamber Data no. : 47  
 Dis. / Ant. : 3m 2015 VULB 9168-493 Ant. pol. : HORIZONTAL  
 Limit : FCC PART 15 B (3M)  
 Env. / Ins. : 24°C/56% Engineer : Even\_Deng  
 EUT : LCD TV M/N:48FS3750  
 Power rating : AC 120V/60Hz  
 Test Mode : Running"H"Pattern And 1KHz Playing  
 HDMI 3:1920\*1080@60Hz

No.	Freq. (MHz)	Ant. Factor (dB/m)	Cable Loss (dB)	Reading (dBuV)	Emission Level (dBuV/m)	Limits (dBuV/m)	Margin (dB)	Remark
1	50.41	14.40	0.81	13.04	28.25	40.00	11.75	QP
2	145.51	14.16	1.29	20.17	35.62	43.50	7.88	QP
3	219.84	10.90	1.57	25.72	38.19	46.00	7.81	QP
4	299.04	14.08	1.90	25.67	41.65	46.00	4.35	QP
5	742.81	21.83	3.12	16.92	41.87	46.00	4.13	QP
6	878.32	23.40	3.43	10.56	37.39	46.00	8.61	QP

Remarks: 1. Emission Level= Antenna Factor + Cable Loss + Reading.  
 2. The emission levels that are 20dB below the official limit are not reported.

3. The worst emission was detected at 742.81 MHz with corrected signal level of 41.87 dBμV/m (Limit is 46.00 dBμV/m) when the antenna was at horizontal polarization and at 1.0m high and the turn table was at 75°.
4. 0° was the table front facing the antenna. Degree is calculated from 0° clockwise facing the antenna.

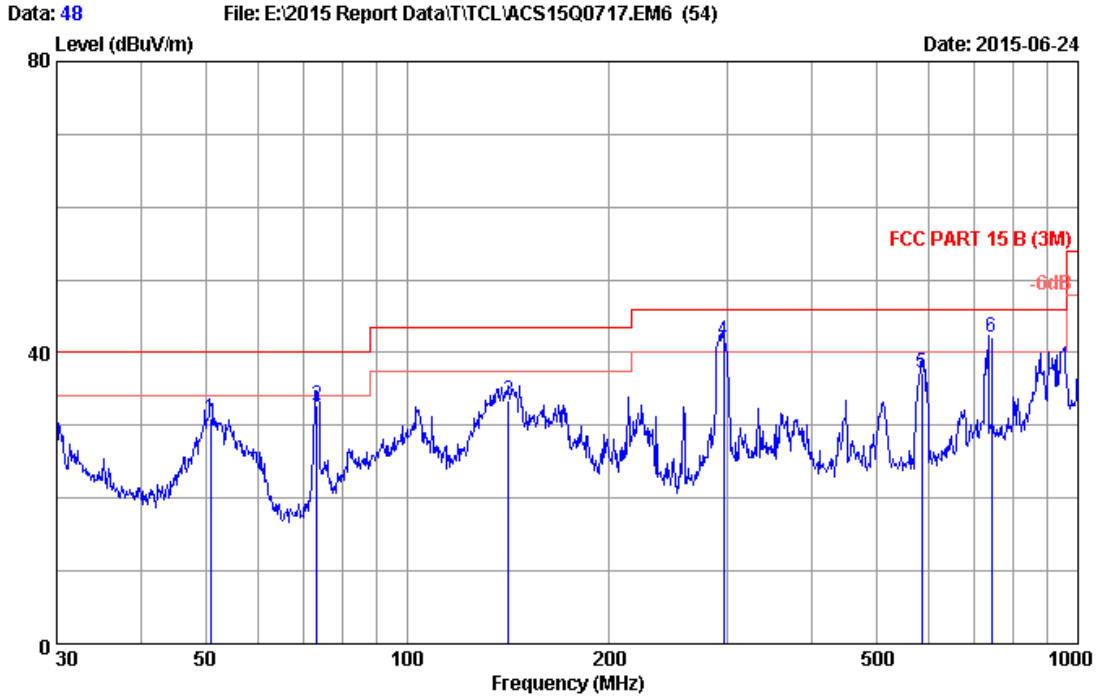

Site no. : 3m Chamber Data no. : 48  
 Dis. / Ant. : 3m 2015 VULB 9168-493 Ant. pol. : VERTICAL  
 Limit : FCC PART 15 B (3M)  
 Env. / Ins. : 24°C/56% Engineer : Even\_Deng  
 EUT : LCD TV M/N:48FS3750  
 Power rating : AC 120V/60Hz  
 Test Mode : Running "H" Pattern And 1KHz Playing  
 HDMI 3:1920\*1080@60Hz

No.	Freq. (MHz)	Ant. Factor (dB/m)	Cable Loss (dB)	Reading (dBuV)	Emission Level (dBuV/m)	Limits (dBuV/m)	Margin (dB)	Remark
1	50.94	14.30	0.81	15.92	31.03	40.00	8.97	QP
2	73.36	10.87	0.93	21.06	32.86	40.00	7.14	QP
3	141.33	14.05	1.27	18.13	33.45	43.50	10.05	QP
4	296.18	14.00	1.87	25.77	41.64	46.00	4.36	QP
5	584.79	19.72	2.74	14.68	37.14	46.00	8.86	QP
6	742.68	21.83	3.12	17.27	42.22	46.00	3.78	QP

- Remarks:
1. Emission Level= Antenna Factor + Cable Loss + Reading.
  2. The emission levels that are 20dB below the official limit are not reported.
  3. The worst emission was detected at 742.68 MHz with corrected signal level of 42.22 dBμV/m (Limit is 46.00 dBμV/m) when the antenna was at horizontal polarization and at 1.0m high and the turn table was at 75°.
  4. 0° was the table front facing the antenna. Degree is calculated from 0° clockwise facing the antenna.

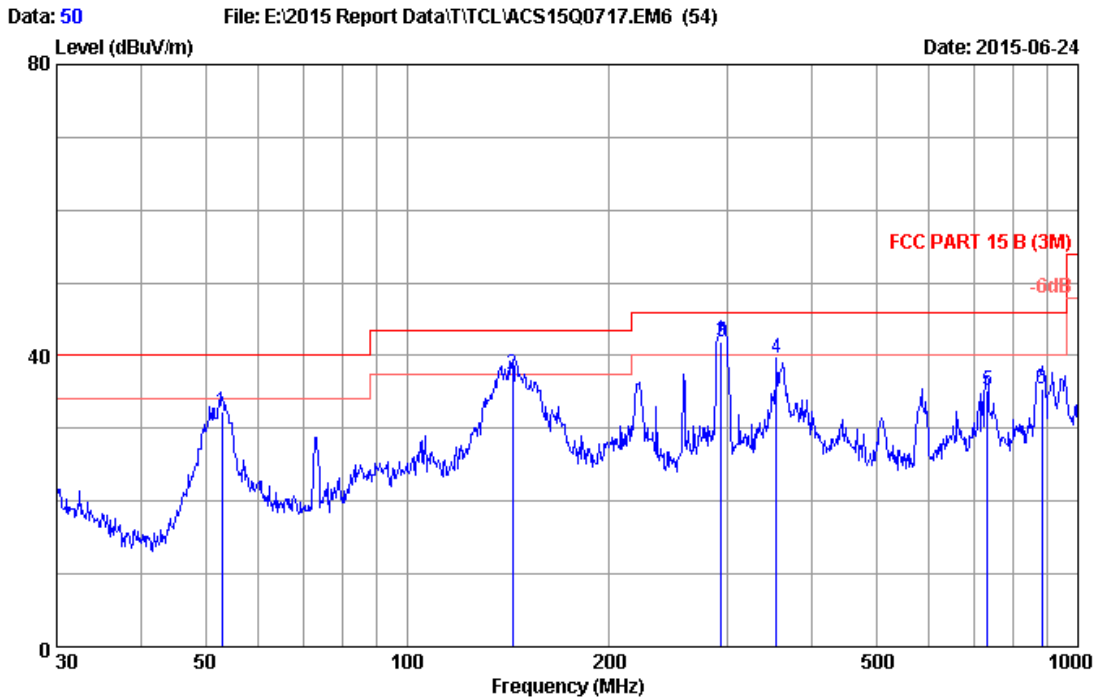

Site no. : 3m Chamber Data no. : 50  
 Dis. / Ant. : 3m 2015 VULB 9168-493 Ant. pol. : HORIZONTAL  
 Limit : FCC PART 15 B (3M)  
 Env. / Ins. : 24°C/56% Engineer : Even\_Deng  
 EUT : LCD TV M/N:48FS3750  
 Power rating : AC 120V/60Hz  
 Test Mode : TX Mode (WIFI)

No.	Freq. (MHz)	Ant. Factor (dB/m)	Cable Loss (dB)	Reading (dBuV)	Emission Level (dBuV/m)	Limits (dBuV/m)	Margin (dB)	Remark
1	52.95	14.10	0.85	17.30	32.25	40.00	7.75	QP
2	143.33	14.11	1.27	22.14	37.52	43.50	5.98	QP
3	294.11	13.95	1.87	25.98	41.80	46.00	4.20	QP
4	355.43	15.24	2.07	22.35	39.66	46.00	6.34	QP
5	731.92	21.72	3.10	10.44	35.26	46.00	10.74	QP
6	884.50	23.48	3.45	8.60	35.53	46.00	10.47	QP

Remarks: 1. Emission Level= Antenna Factor + Cable Loss + Reading.  
 2. The emission levels that are 20dB below the official limit are not reported.

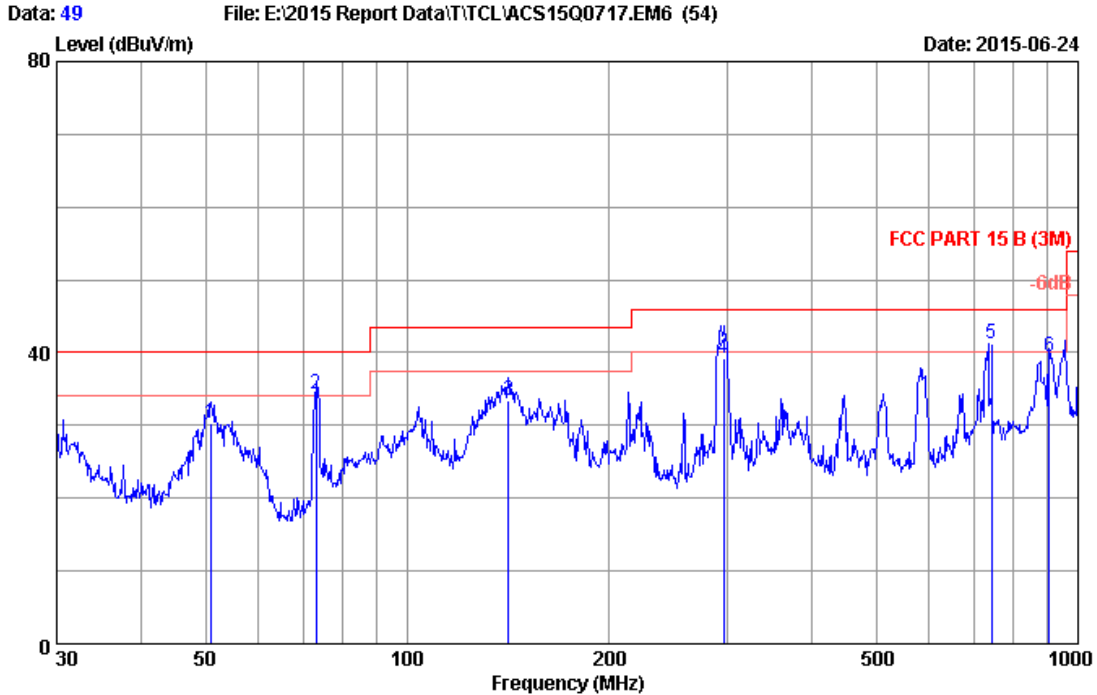

Site no. : 3m Chamber Data no. : 49  
 Dis. / Ant. : 3m 2015 VULB 9168-493 Ant. pol. : VERTICAL  
 Limit : FCC PART 15 B (3M)  
 Env. / Ins. : 24°C/56% Engineer : Even\_Deng  
 EUT : LCD TV M/N:48FS3750  
 Power rating : AC 120V/60Hz  
 Test Mode : TX Mode (WIFI)

No.	Freq. (MHz)	Ant. Factor (dB/m)	Cable Loss (dB)	Reading (dBUV)	Emission Level (dBUV/m)	Limits (dBUV/m)	Margin (dB)	Remark
1	50.94	14.30	0.81	15.13	30.24	40.00	9.76	QP
2	73.10	11.05	0.93	22.23	34.21	40.00	5.79	QP
3	141.33	14.05	1.27	18.19	33.51	43.50	9.99	QP
4	296.04	14.00	1.87	23.40	39.27	46.00	6.73	QP
5	742.49	21.83	3.12	16.24	41.19	46.00	4.81	QP
6	906.48	23.77	3.50	12.26	39.53	46.00	6.47	QP

Remarks: 1. Emission Level= Antenna Factor + Cable Loss + Reading.  
 2. The emission levels that are 20dB below the official limit are not reported.

1GHz~18GHz

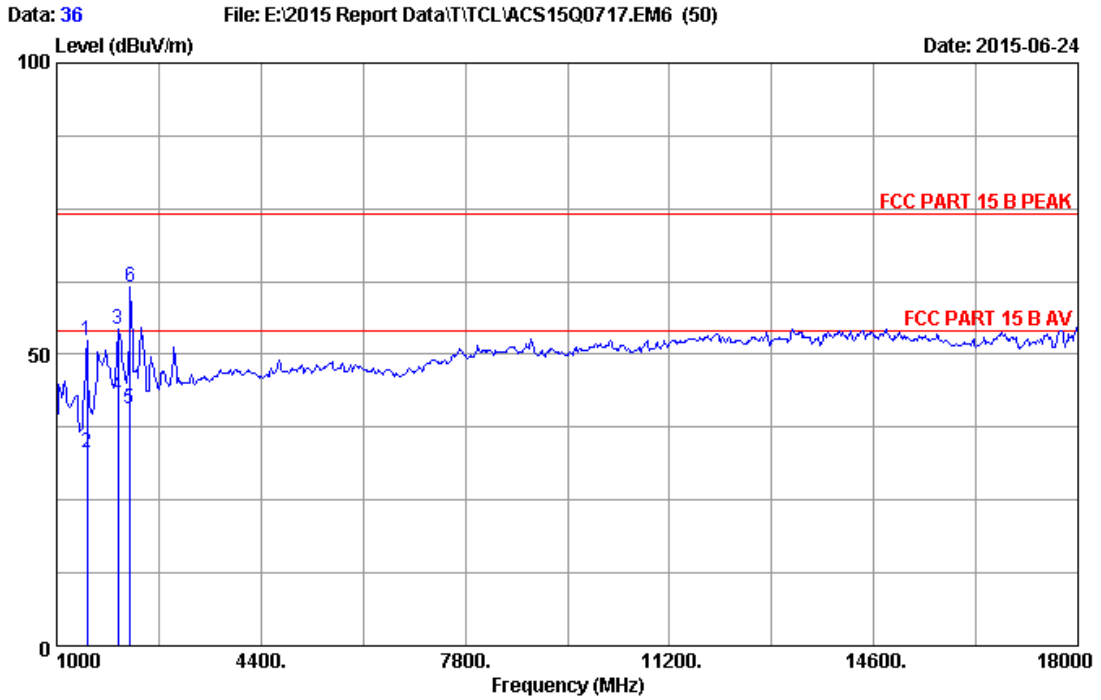

Site no. : 3m Chamber Data no. : 36  
 Dis. / Ant. : 3m 2014 3115 9607-4877 Ant. pol. : HORIZONTAL  
 Limit : FCC PART 15 B PEAK  
 Env. / Ins. : 24°C/56% Engineer : Donjon  
 EUT : LCD TV M/N:48FS3750  
 Power rating : AC 120V/60Hz  
 Test Mode : PC Mode  
 : Running"H"Pattern And 1KHz Playing  
 HDMI 1:1920\*1080@60Hz

No.	Freq. (MHz)	Ant. Factor (dB/m)	Cable Loss (dB)	Amp factor (dB)	Reading (dBuV)	Emission Level (dBuV/m)	Limits (dBuV/m)	Margin (dB)	Remark
1	1510.00	26.04	2.43	35.66	59.57	52.38	74.00	21.62	Peak
2	1511.78	26.04	2.43	35.66	40.29	33.10	54.00	20.90	Average
3	2020.00	27.64	2.74	33.92	57.84	54.30	74.00	19.70	Peak
4	2021.59	27.64	2.74	33.92	46.52	42.98	54.00	11.02	Average
5	2212.53	27.96	2.74	33.44	43.30	40.56	54.00	13.44	Average
6	2224.00	27.98	2.74	33.44	64.35	61.63	74.00	12.37	Peak

Remarks: 1. Emission Level= Antenna Factor + Cable Loss + Reading -Amp factor.  
 2. The emission levels that are 20dB below the official limit are not reported.



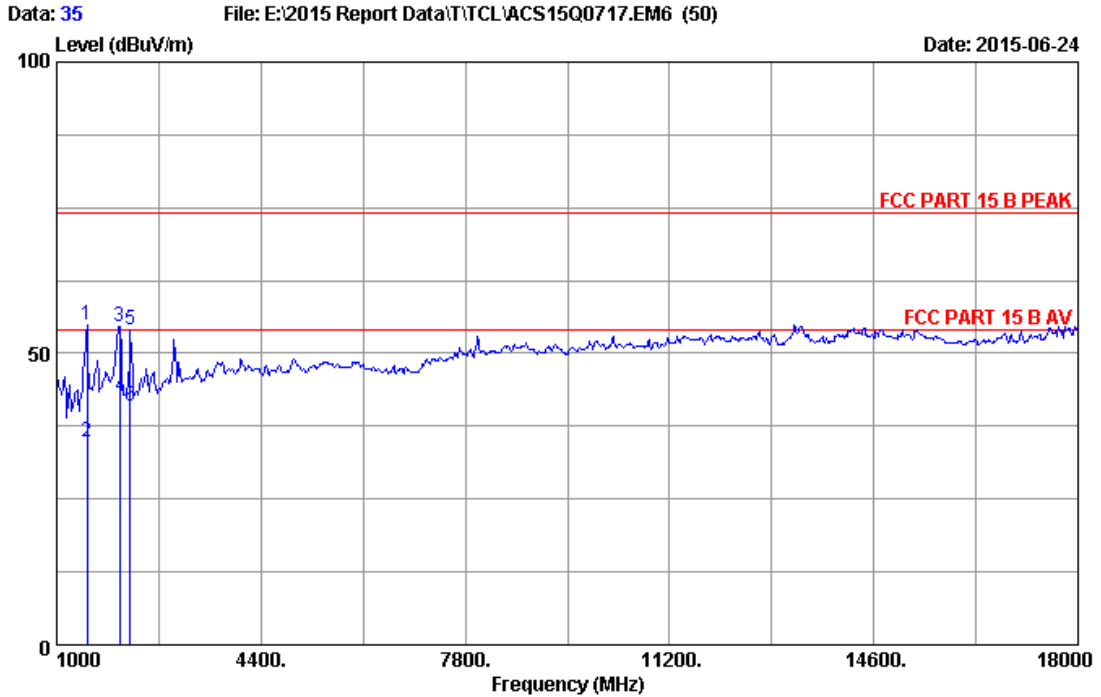

Site no. : 3m Chamber Data no. : 35  
 Dis. / Ant. : 3m 2014 3115 9607-4877 Ant. pol. : VERTICAL  
 Limit : FCC PART 15 B PEAK  
 Env. / Ins. : 24°C/56% Engineer : Donjon  
 EUT : LCD TV M/N:48FS3750  
 Power rating : AC 120V/60Hz  
 Test Mode : PC Mode  
 : Running"H"Pattern And 1KHz Playing  
 HDMI 1:1920\*1080@60Hz

No.	Freq. (MHz)	Ant. Factor (dB/m)	Cable Loss (dB)	Amp factor (dB)	Reading (dBuV)	Emission Level (dBuV/m)	Limits (dBuV/m)	Margin (dB)	Remark
1	1510.00	26.04	2.43	35.66	62.10	54.91	74.00	19.09	Peak
2	1511.59	26.04	2.43	35.66	41.98	34.79	54.00	19.21	Average
3	2054.00	27.70	2.74	33.86	58.06	54.64	74.00	19.36	Peak
4	2054.36	27.70	2.74	33.86	45.96	42.54	54.00	11.46	Average
5	2224.00	27.98	2.74	33.44	56.78	54.06	74.00	19.94	Peak
6	2224.15	27.98	2.74	33.44	43.80	41.08	54.00	12.92	Average

Remarks: 1. Emission Level= Antenna Factor + Cable Loss + Reading -Amp factor.  
 2. The emission levels that are 20dB below the official limit are not reported.

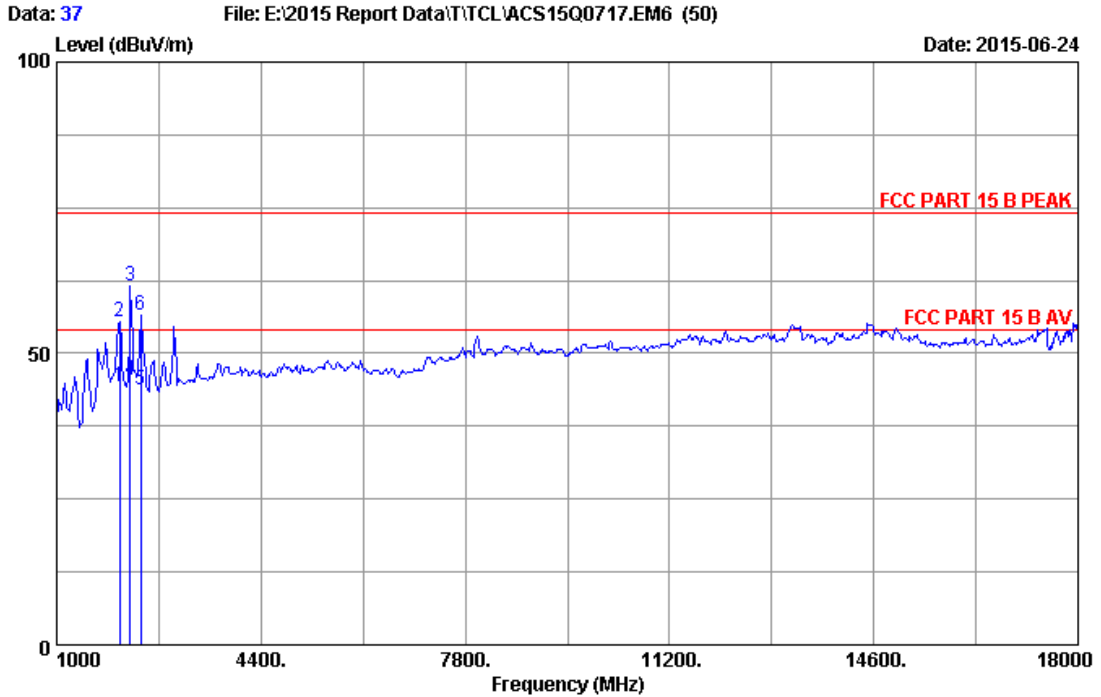

Site no. : 3m Chamber Data no. : 37  
 Dis. / Ant. : 3m 2014 3115 9607-4877 Ant. pol. : HORIZONTAL  
 Limit : FCC PART 15 B PEAK  
 Env. / Ins. : 24°C/56% Engineer : Donjon  
 EUT : LCD TV M/N:48FS3750  
 Power rating : AC 120V/60Hz  
 Test Mode : PC Mode  
 : Running"H"Pattern And 1KHz Playing  
 HDMI 2:1920\*1080@60Hz

No.	Freq. (MHz)	Ant. Factor (dB/m)	Cable Loss (dB)	Amp factor (dB)	Reading (dBuV)	Emission Level (dBuV/m)	Limits (dBuV/m)	Margin (dB)	Remark
1	2053.96	27.70	2.74	33.86	47.70	44.28	54.00	9.72	Average
2	2054.00	27.70	2.74	33.86	58.74	55.32	74.00	18.68	Peak
3	2224.00	27.98	2.74	33.44	64.25	61.53	74.00	12.47	Peak
4	2224.36	27.98	2.74	33.44	48.06	45.34	54.00	8.66	Average
5	2393.51	28.24	2.75	33.02	45.80	43.77	54.00	10.23	Average
6	2394.00	28.24	2.75	33.02	58.57	56.54	74.00	17.46	Peak

Remarks: 1. Emission Level= Antenna Factor + Cable Loss + Reading -Amp factor.  
 2. The emission levels that are 20dB below the official limit are not reported.

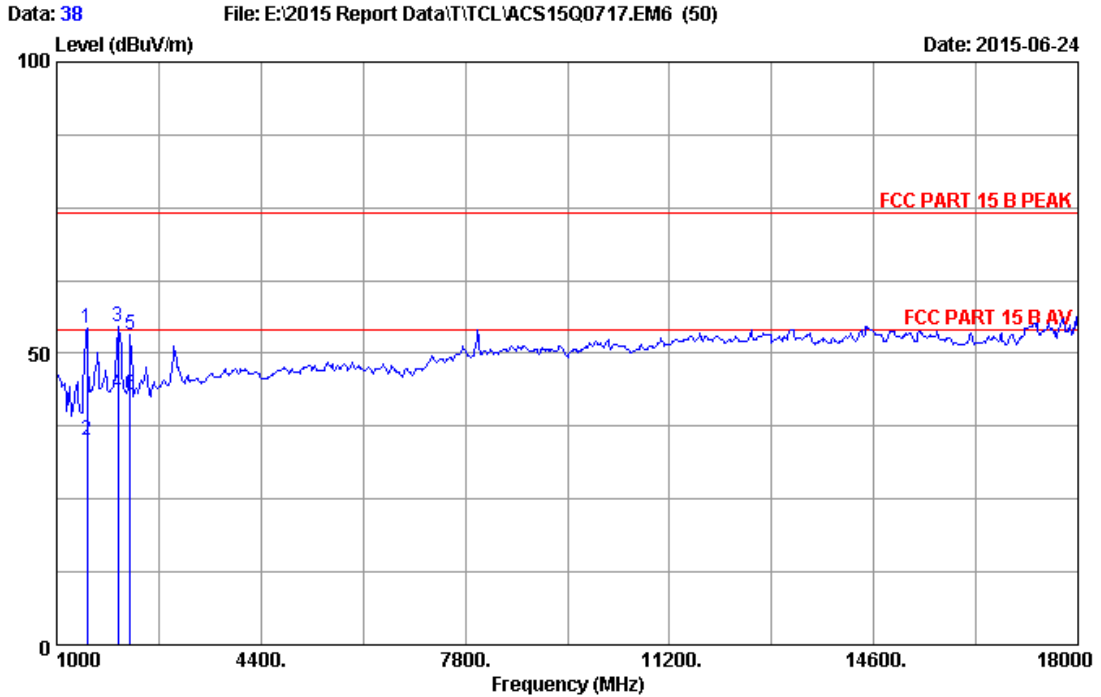

Site no. : 3m Chamber Data no. : 38  
 Dis. / Ant. : 3m 2014 3115 9607-4877 Ant. pol. : VERTICAL  
 Limit : FCC PART 15 B PEAK  
 Env. / Ins. : 24°C/56% Engineer : Donjon  
 EUT : LCD TV M/N:48FS3750  
 Power rating : AC 120V/60Hz  
 Test Mode : PC Mode  
 : Running"H"Pattern And 1KHz Playing  
 HDMI 2:1920\*1080@60Hz

No.	Freq. (MHz)	Ant. Factor (dB/m)	Cable Loss (dB)	Amp factor (dB)	Reading (dBuV)	Emission Level (dBuV/m)	Limits (dBuV/m)	Margin (dB)	Remark
1	1510.00	26.04	2.43	35.66	61.53	54.34	74.00	19.66	Peak
2	1511.60	26.04	2.43	35.66	42.29	35.10	54.00	18.90	Average
3	2020.00	27.64	2.74	33.92	58.05	54.51	74.00	19.49	Peak
4	2021.59	27.64	2.74	33.92	46.76	43.22	54.00	10.78	Average
5	2224.00	27.98	2.74	33.44	55.97	53.25	74.00	20.75	Peak
6	2224.33	27.98	2.74	33.44	45.55	42.83	54.00	11.17	Average

Remarks: 1. Emission Level= Antenna Factor + Cable Loss + Reading -Amp factor.  
 2. The emission levels that are 20dB below the official limit are not reported.

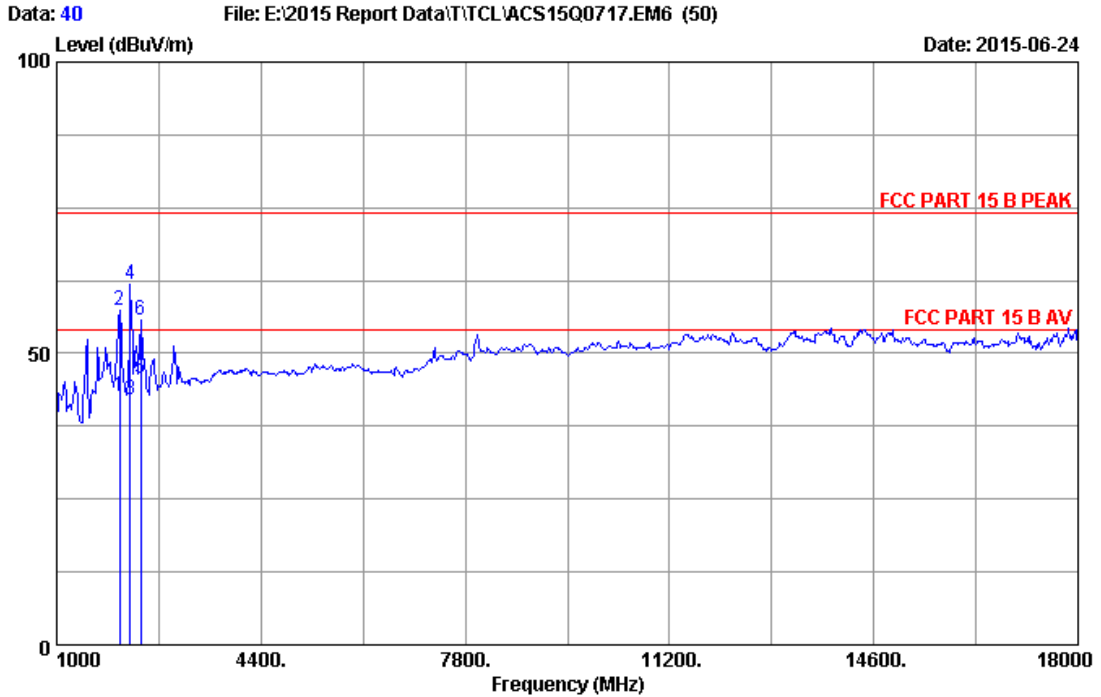

Site no. : 3m Chamber Data no. : 40  
 Dis. / Ant. : 3m 2014 3115 9607-4877 Ant. pol. : HORIZONTAL  
 Limit : FCC PART 15 B PEAK  
 Env. / Ins. : 24°C/56% Engineer : Donjon  
 EUT : LCD TV M/N:48FS3750  
 Power rating : AC 120V/60Hz  
 Test Mode : PC Mode  
 : Running"H"Pattern And 1KHz Playing  
 HDMI 3:1920\*1080@60Hz

No.	Freq. (MHz)	Ant. Factor (dB/m)	Cable Loss (dB)	Amp factor (dB)	Reading (dBuV)	Emission Level (dBuV/m)	Limits (dBuV/m)	Margin (dB)	Remark
1	2053.80	27.70	2.74	33.86	46.06	42.64	54.00	11.36	Average
2	2054.00	27.70	2.74	33.86	60.78	57.36	74.00	16.64	Peak
3	2223.16	27.98	2.74	33.44	44.84	42.12	54.00	11.88	Average
4	2224.00	27.98	2.74	33.44	64.51	61.79	74.00	12.21	Peak
5	2393.81	28.24	2.75	33.02	47.73	45.70	54.00	8.30	Average
6	2394.00	28.24	2.75	33.02	57.72	55.69	74.00	18.31	Peak

Remarks: 1. Emission Level= Antenna Factor + Cable Loss + Reading -Amp factor.  
 2. The emission levels that are 20dB below the official limit are not reported.

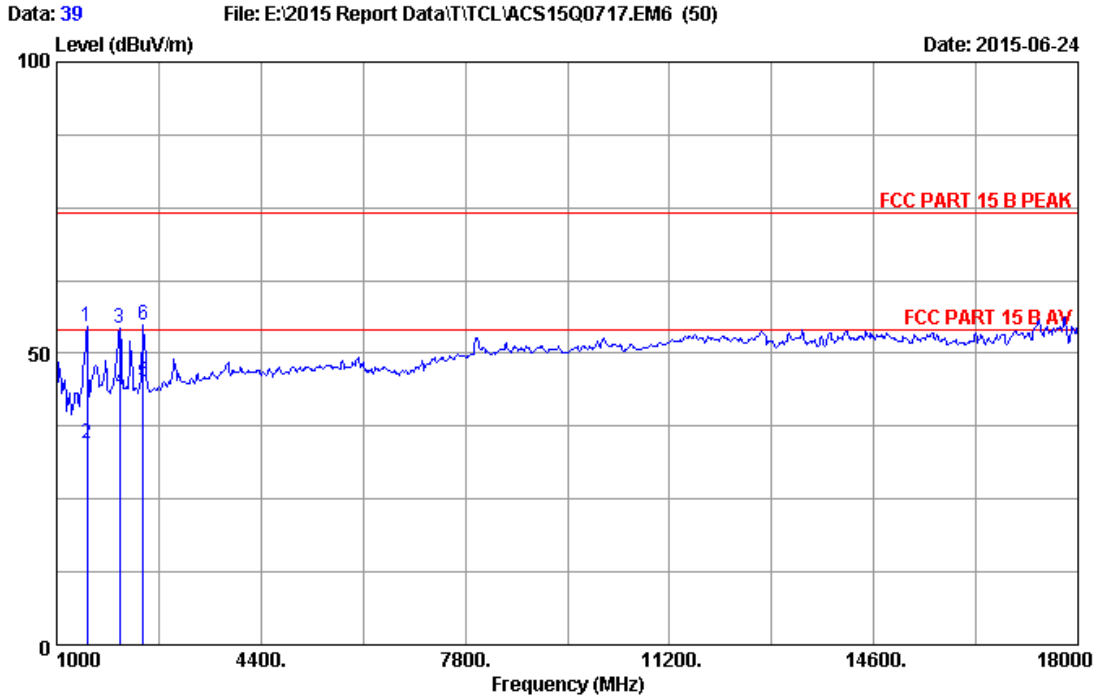

Site no. : 3m Chamber Data no. : 39  
 Dis. / Ant. : 3m 2014 3115 9607-4877 Ant. pol. : VERTICAL  
 Limit : FCC PART 15 B PEAK  
 Env. / Ins. : 24°C/56% Engineer : Donjon  
 EUT : LCD TV M/N:48FS3750  
 Power rating : AC 120V/60Hz  
 Test Mode : PC Mode  
 : Running"H"Pattern And 1KHz Playing  
 HDMI 3:1920\*1080@60Hz

No.	Freq. (MHz)	Ant. Factor (dB/m)	Cable Loss (dB)	Amp factor (dB)	Reading (dBuV)	Emission Level (dBuV/m)	Limits (dBuV/m)	Margin (dB)	Remark
1	1510.00	26.04	2.43	35.66	61.79	54.60	74.00	19.40	Peak
2	1511.20	26.04	2.43	35.66	41.74	34.55	54.00	19.45	Average
3	2054.00	27.70	2.74	33.86	57.75	54.33	74.00	19.67	Peak
4	2054.33	27.70	2.74	33.86	47.08	43.66	54.00	10.34	Average
5	2443.65	28.32	2.75	32.90	47.05	45.22	54.00	8.78	Average
6	2445.00	28.32	2.75	32.90	56.84	55.01	74.00	18.99	Peak

Remarks: 1. Emission Level= Antenna Factor + Cable Loss + Reading -Amp factor.  
 2. The emission levels that are 20dB below the official limit are not reported.

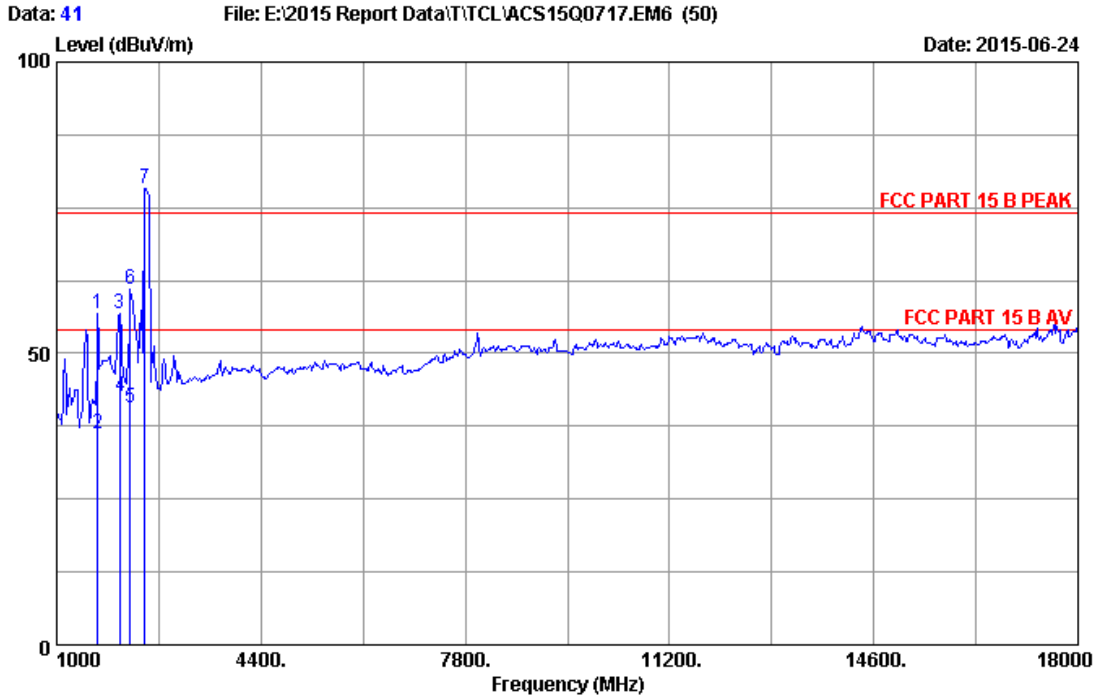

Site no. : 3m Chamber Data no. : 41  
 Dis. / Ant. : 3m 2014 3115 9607-4877 Ant. pol. : HORIZONTAL  
 Limit : FCC PART 15 B PEAK  
 Env. / Ins. : 24°C/56% Engineer : Donjon  
 EUT : LCD TV M/N:48FS3750  
 Power rating : AC 120V/60Hz  
 Test Mode : TX Mode (WIFI)  
 :

No.	Freq. (MHz)	Ant. Factor (dB/m)	Cable Loss (dB)	Amp factor (dB)	Reading (dBuV)	Emission Level (dBuV/m)	Limits (dBuV/m)	Margin (dB)	Remark
1	1680.00	26.63	2.54	35.04	62.77	56.90	74.00	17.10	Peak
2	1681.50	26.64	2.54	35.04	42.14	36.28	54.00	17.72	Average
3	2054.00	27.70	2.74	33.86	60.34	56.92	74.00	17.08	Peak
4	2054.11	27.70	2.74	33.86	46.09	42.67	54.00	11.33	Average
5	2223.95	27.98	2.74	33.44	43.39	40.67	54.00	13.33	Average
6	2224.00	27.98	2.74	33.44	63.76	61.04	74.00	12.96	Peak
7	2460.00	28.34	2.75	32.90	79.98	78.17			

Remarks: 1. Emission Level= Antenna Factor + Cable Loss + Reading - Amp factor.  
 2. The emission levels that are 20dB below the official limit are not reported.

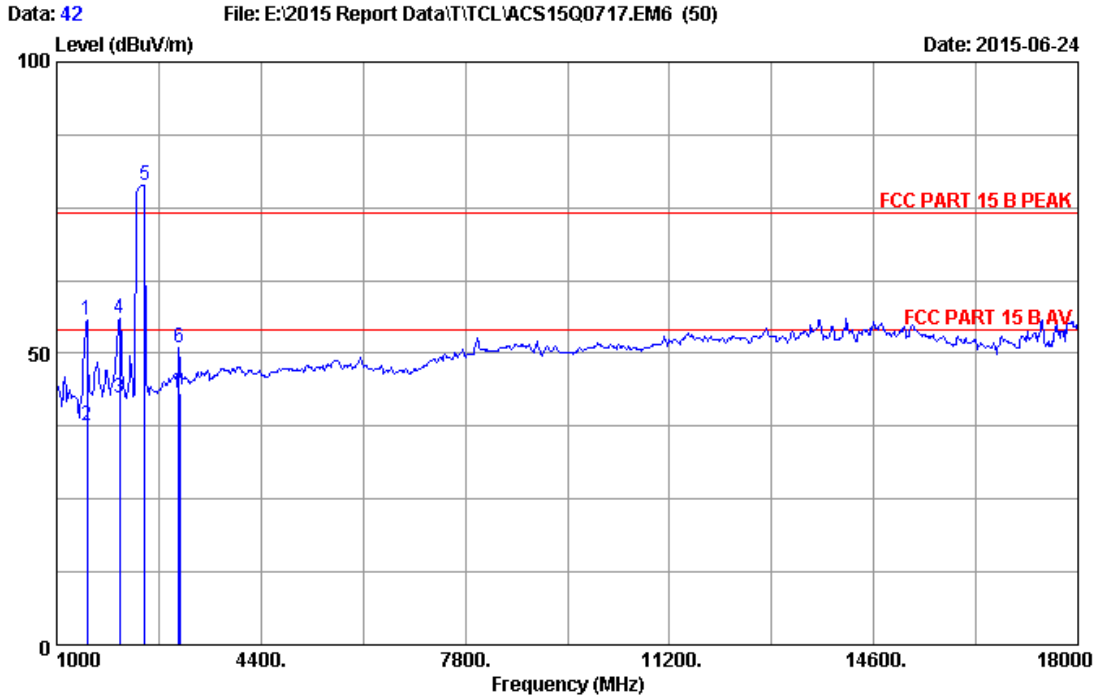

Site no. : 3m Chamber Data no. : 42  
 Dis. / Ant. : 3m 2014 3115 9607-4877 Ant. pol. : VERTICAL  
 Limit : FCC PART 15 B PEAK  
 Env. / Ins. : 24°C/56% Engineer : Donjon  
 EUT : LCD TV M/N:48FS3750  
 Power rating : AC 120V/60Hz  
 Test Mode : TX Mode (WIFI)  
 :

No.	Freq. (MHz)	Ant. Factor (dB/m)	Cable Loss (dB)	Amp factor (dB)	Reading (dBuV)	Emission Level (dBuV/m)	Limits (dBuV/m)	Margin (dB)	Remark
1	1510.00	26.04	2.43	35.66	62.86	55.67	74.00	18.33	Peak
2	1511.98	26.04	2.43	35.66	44.72	37.53	54.00	16.47	Average
3	2051.46	27.69	2.74	33.86	45.79	42.36	54.00	11.64	Average
4	2054.00	27.70	2.74	33.86	59.46	56.04	74.00	17.96	Peak
5	2460.00	28.34	2.75	32.90	80.69	78.88			
6	3040.00	30.11	3.16	31.60	49.20	50.87	74.00	23.13	Peak
7	3041.26	30.12	3.16	31.60	41.47	43.15	54.00	10.85	Average

Remarks: 1. Emission Level= Antenna Factor + Cable Loss + Reading - Amp factor.  
 2. The emission levels that are 20dB below the official limit are not reported.

## 5. DEVIATION TO TEST SPECIFICATIONS

[NONE]