



FCC ID: W8U48FD2700

APPLICATION OF CERTIFICATION

For

TTE Technology Inc.

LCD TV

| Brand Name | Model Number |
|------------|--|
| TCL | 48FD2700; 48FD2710; 48FD2730; 48FD2740 |

FCC ID: W8U48FD2700

Prepared for : TTE Technology Inc.
2455 Anselmo Drive, Suite 101, Corona, CA 92879

Prepared By: Audix Technology (Shenzhen) Co., Ltd.
No. 6, Ke Feng Rd., 52 Block,
Shenzhen Science & Industrial Park,
Nantou, Shenzhen, Guangdong, China

Tel: (0755) 26639496
Fax: (0755) 26632877

Report Number : ACS- F15176
Date of Test : Jun.10~11, 2015
Date of Report : Jul.02, 2015

TABLE OF CONTENTS

| Description | Page |
|--|-------------|
| Test Report Certification | |
| 1. SUMMARY OF STANDARDS AND RESULTS | 1-1 |
| 1.1. Description of Standards and Results | 1-1 |
| 2. GENERAL INFORMATION..... | 2-1 |
| 2.1. Description of Device (EUT)..... | 2-1 |
| 2.2. Tested Supporting System Details | 2-2 |
| 2.3. Block diagram of connection between the EUT and simulators..... | 2-3 |
| 2.4. Test Facility | 2-4 |
| 2.5. Measurement Uncertainty (95% confidence levels, k=2)..... | 2-4 |
| 3. POWER LINE CONDUCTED EMISSION MEASUREMENT..... | 3-1 |
| 3.1. Test Equipment..... | 3-1 |
| 3.2. Block Diagram of Test Setup..... | 3-1 |
| 3.3. Power Line Conducted Emission Test Limits | 3-1 |
| 3.4. Configuration of EUT on Test..... | 3-2 |
| 3.5. Operating Condition of EUT | 3-2 |
| 3.6. Test Procedure | 3-2 |
| 3.7. Conducted Emission at Mains Terminals Test Results..... | 3-3 |
| 4. RADIATED EMISSION MEASUREMENT..... | 4-1 |
| 4.1. Test Equipment..... | 4-1 |
| 4.2. Block Diagram of Test Setup..... | 4-2 |
| 4.3. Radiated Emission Limit | 4-3 |
| 4.4. EUT Configuration on Test | 4-3 |
| 4.5. Operating Condition of EUT | 4-3 |
| 4.6. Test Procedure | 4-3 |
| 4.7. Radiated Emission Test Results..... | 4-4 |
| 5. DEVIATION TO TEST SPECIFICATIONS | 5-1 |
| 6. PHOTOGRAPH | 6-1 |
| 6.1. Photos of Power Line Conducted Emission Test..... | 6-1 |
| 6.2. Photos of Radiated Emission Test (In Anechoic Chamber) | 6-2 |
| 7. PHOTOS OF THE EUT | 7-1 |

TEST REPORT CERTIFICATION

Applicant : TTE Technology Inc.
 Manufacturer : TCL Optoelectronics Technology (Huizhou) CO., Ltd.
 EUT Description : LCD TV
 FCC ID : W8U48FD2700
 (A) Model No. & :

| | |
|------------|--|
| Brand Name | Model Number |
| TCL | 48FD2700; 48FD2710; 48FD2730; 48FD2740 |

 Brand Name
 (B) Power Supply : AC 120V/60Hz
 (C) Test Voltage : AC 120V/60Hz

Measurement Standard Used:

FCC Rules and Regulations Part 15 Subpart B Class B 2014

The device described above is tested by AUDIX TECHNOLOGY (SHENZHEN) CO., LTD. to determine the maximum emission levels emanating from the device. The maximum emission levels are compared to the FCC Part 15 Subpart B Class B limits both conducted and radiated emissions. The test results are contained in this test report and AUDIX TECHNOLOGY (SHENZHEN) CO., LTD. is assumed of full responsibility for the accuracy and completeness of these tests. This report contains data that are not covered by the NVLAP accreditation.

After the test, our opinion is that EUT compliance with the requirement of the above standards.

This Report is made under FCC Part 2.1075. No modifications were required during testing to bring this product into compliance.

This report applies to above tested sample only. This report shall not be reproduced in parts without written approval of AUDIX TECHNOLOGY (SHENZHEN) CO., LTD.

The report must not be used by the client to claim product certification, approval, or endorsement by NVLAP, NIST, or any agency of the federal government.

Date of Test : Jun.10~11, 2015 Report of date: Jul.02, 2015

Prepared by : Eva Yin / Assistant Reviewed by : Sun Zeng / Assistant Manager

 信華科技(深圳)有限公司
 Audix Technology (Shenzhen) Co., Ltd.
 EMC 部門報告專用章
 Stamp only for EMC Dept. Report
 Signature: David Jin
 David Jin / Manager

Approved & Authorized Signer :

1. SUMMARY OF STANDARDS AND RESULTS

1.1. Description of Standards and Results

The EUT have been tested according to the applicable standards as referenced below.

| EMISSION | | | |
|-------------------------------------|---------------------------------------|---------|---|
| Description of Test Item | Standard | Results | Remarks |
| Power Line Conducted Emission Test | FCC Part 15: 2014 ANSI C63.4: 2009 | PASS | Meets Class B Limit Minimum passing margin is 8.94 dB at 2.834 MHz |
| Radiated Emission Test (30-1000MHz) | FCC Part 15: 2014 ANSI C63.4: 2009 | PASS | Meets Class B Limit Minimum passing margin is 3.46 dB at 891.05 MHz |
| Radiated Emission Test (1-5GHz) | FCC Part 15: 2014 ANSI C63.4: 2009 | PASS | Meets Class B Limit Minimum passing margin is 8.47 dB at 1632.58MHz |

2. GENERAL INFORMATION

2.1. Description of Device (EUT)

Description : LCD TV

| Model Number& : Brand Name | Brand Name | Model Number |
|-------------------------------|------------|--|
| | TCL | 48FD2700; 48FD2710; 48FD2730; 48FD2740 |

(All 48 " models are identical except for different appearance (only for color, silk-screen and decorative parts) and model number for trading purpose.)

FCC ID : W8U48FD2700

Test Mode : 48FD2700

Applicant : TTE Technology Inc.
2455 Anselmo Drive, Suite 101, Corona, CA 92879

Manufacturer : TCL Optoelectronics Technology (Huizhou) CO., Ltd.
78#, Huifeng 4th Road, Zhongkai New and High-tech Industries
Development Zone, Huizhou, Guangdong, China

| FREQUENCIES USED AND GENERATED WITHIN DEVICE | |
|--|--------|
| LVDS (HD) | 78MHZ |
| LVDS (FHD) | 75MHZ |
| IF | 6MHz |
| IC | 800MHz |

Internal photos of the EUT shows AC sockets line, FCC WIRE line, debug with the countermeasure scheme, these countermeasures and EUT production together.

Date of Test : Jun.10~11, 2015

Date of Receipt : Jun.08, 2015

Sample Type : Prototype production

2.2. Tested Supporting System Details

| | Description | ACS No. | Manufacturer | Model | Serial Number | Approved type |
|----|---|--|--------------|------------|------------------------------|---|
| 1. | Personal Computer | Test PC S | DELL | Vostro 470 | 2SP05W1 | <input checked="" type="checkbox"/> FCC DoC <input checked="" type="checkbox"/> BSMI ID:R33002 |
| | | Power Cord: Unshielded, Detachable, 1.8m Display Card: HD3450 (DVI+VGA+HDMI) | | | | |
| 2. | USB Keyboard | ACS-EMC- K04R | DELL | SK-8115 | CN-ODJ313-71616 -6BB-049J | <input checked="" type="checkbox"/> FCC DoC <input checked="" type="checkbox"/> BSMI ID: T3A002 |
| | | Data Cable: shielded, Undetachable, 2.0m | | | | |
| 3. | Printer | ACS-EMC-PT04 | HP | C9079A | N/A | <input checked="" type="checkbox"/> FCC DoC <input checked="" type="checkbox"/> BSMI ID: R33001 |
| | | USB Cable: Shielded, Detachable, 1.8m Power Cord: Unshielded, Detachable, 1.8m Power Adapter: HP, M/N: 0957-2119, BSMI ID: R33030, DC Cable: Unshielded, Detachable, 1.5m | | | | |
| 4. | USB Mouse | ACS-EMC-M04R | DELL | M056UO | 512024282 | <input checked="" type="checkbox"/> FCC DoC <input checked="" type="checkbox"/> BSMI ID: R41108 |
| | | Data Cable: shielded, Undetachable, 1.8m | | | | |
| 5. | iPod | ACS-EMC-IP01 | APPLE | A1199 | YM711H3LVQ5 | <input checked="" type="checkbox"/> FCC DoC <input checked="" type="checkbox"/> BSMI ID: R33057 |
| | | Data Cable: Shielded, Detachable, 1.0m | | | | |
| 6. | HDD | ACS-EMC-HDD01 | Terasys | F12-UF | A0100215-539001 8 | <input checked="" type="checkbox"/> FCC DoC <input checked="" type="checkbox"/> BSMI ID: 4912A022 |
| | | USB Cable: Shielded, Detachable, 1.8m | | | | |
| 7. | Power Cable: Unshielded, Detachable, 1.8m HDMI Cable: Shielded, Detachable, 1.8m AV In: Unshielded, Detachable, 1.8m USB Cable: Unshielded, Detachable, 1.8m TV Cable: Unshielded, Detachable, 1.8m Component Cable: Unshielded, Detachable, 1.8m SPDIF: Unshielded, Detachable, 1.8m | | | | | |

2.3. Block diagram of connection between the EUT and simulators

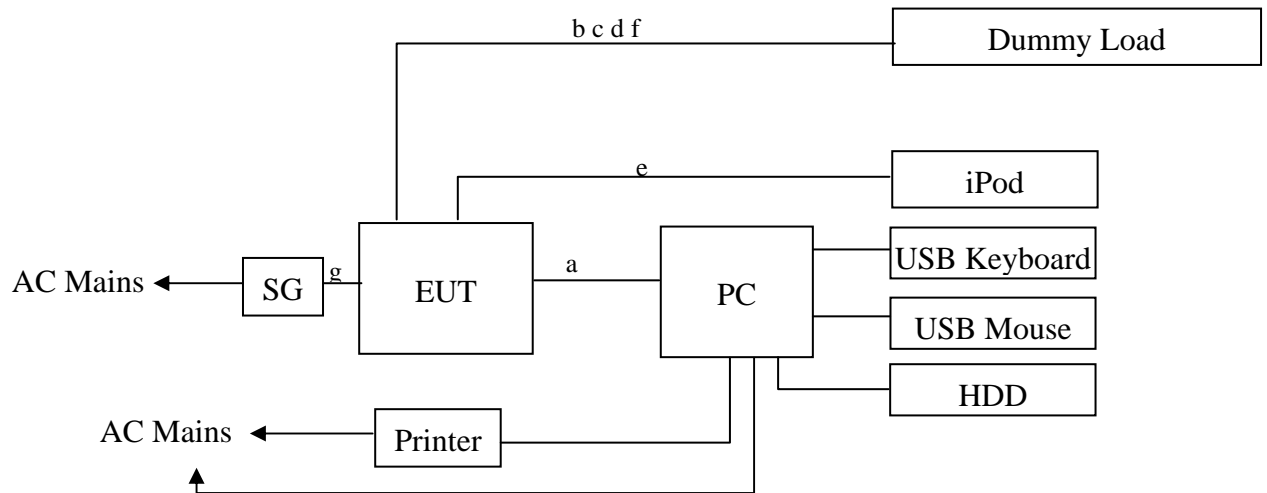

- a: HDMI Cable
- b: HDMI*2 Cable
- c: Component In Cable
- d: (R+L) Audio In Cable
- e: USB Cable
- f: SPDIF Cable
- g: TV Cable

(EUT: LCD TV)

2.4. Test Facility

Site Description

Name of Firm : Audix Technology (Shenzhen) Co., Ltd.
No. 6, Ke Feng Rd., 52 Block, Shenzhen
Science & Industrial Park, Nantou,
Shenzhen, Guangdong, China

3m Anechoic Chamber : Certificated by FCC, USA
Registration Number: 90454
Valid Date: Dec.30, 2017

3m & 10m Anechoic Chamber : Certificated by FCC, USA
Registration Number: 794232
Valid Date: Oct.31, 2015

EMC Lab. : Accredited by DAkkS, Germany
Registration No: D-PL-12151-01-00
Valid Date: Dec.15, 2016

: Accredited by NVLAP, USA
NVLAP Code: 200372-0
Valid Date: Mar.31, 2016

2.5. Measurement Uncertainty (95% confidence levels, k=2)

| Test Item | Uncertainty |
|--|----------------------------------|
| Uncertainty for Conduction emission test in No. 1 Conduction | 3.1 dB(150kHz to 30MHz) |
| Uncertainty for Radiation Emission test in 3m chamber | 3.3dB(30~200MHz, Polarize: H) |
| | 3.3dB(30~200MHz, Polarize: V) |
| | 3.5dB(200M~1GHz, Polarize: H) |
| | 3.4dB(200M~1GHz, Polarize: V) |
| Uncertainty for Radiation Emission test in 3m chamber (1GHz-18GHz) | 5.1dB(Distance: 3m, Polarize: V) |
| | 5.3dB(Distance: 3m, Polarize: H) |
| Uncertainty for test site temperature and humidity | 3% |
| | 0.6°C |

3. POWER LINE CONDUCTED EMISSION MEASUREMENT

3.1. Test Equipment

| Item | Equipment | Manufacturer | Model No. | Serial No. | Last Cal. | Cal. Interval |
|------|-----------------------------|-----------------|-----------|------------|-----------|---------------|
| 1. | 1# Shielding Room | AUDIX | N/A | N/A | Apr.17,15 | 1 Year |
| 2. | Test Receiver | Rohde & Schwarz | ESCI | 100842 | Apr.28,15 | 1 Year |
| 3. | L.I.S.N.#1 | Rohde & Schwarz | ESH2-Z5 | 100429 | Oct.29,14 | 1 Year |
| 4. | L.I.S.N.#3 | Kyoritsu | KNW-242C | 8-1920-1 | Apr.28,15 | 1 Year |
| 5. | Terminator | Hubersuhner | 50Ω | No.1 | Apr.28,15 | 1 Year |
| 6. | Terminator | Hubersuhner | 50Ω | No.2 | Apr.28,15 | 1 Year |
| 7. | RF Cable | MIYAZAKI | 3D-2W | No.1 | Apr.28,15 | 1 Year |
| 8. | Coaxial Switch | Anritsu | MP59B | 6200766906 | Apr.28,15 | 1 Year |
| 9. | Pulse Limiter | Rohde & Schwarz | ESH3-Z2 | 101838 | Oct.29,14 | 1 Year |
| 10. | MPEG2 Measurement Generator | ROHDE&SCHWARZ | DVG | 100319 | Oct.29,14 | 1 Year |
| 11. | TV Transmitter | ROHDE&SCHWARZ | SFQ | 100521 | Apr.28,15 | 1 Year |
| 12. | Signal Generator | HP | 8648A | 3625U00573 | Apr.28,15 | 1 Year |
| 13. | Pattern Generator | Philips | PM5418 | LO625020 | Apr.28,15 | 1 Year |
| 14. | Test Software | AUDIX | E3 | 6.100913a | N/A | N/A |

3.2. Block Diagram of Test Setup

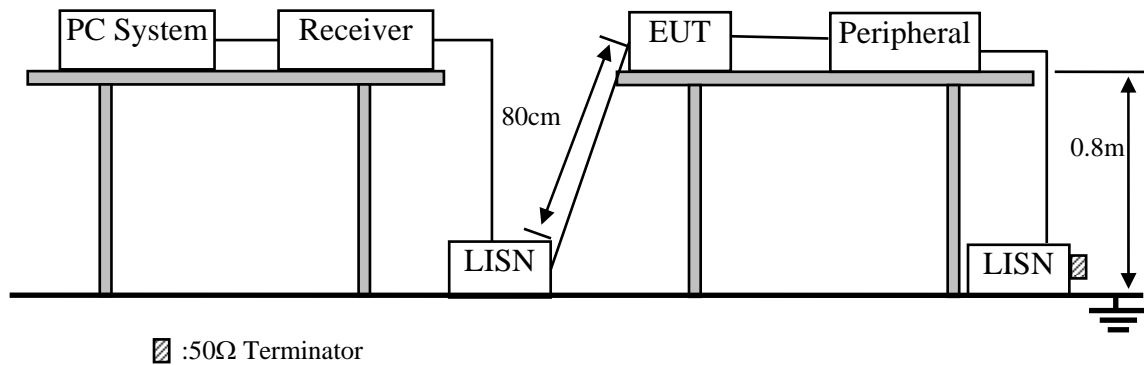

3.3. Power Line Conducted Emission Test Limits

| Frequency | Maximum RF Line Voltage | |
|-----------------|----------------------------|-------------------------|
| | Quasi-Peak Level dB(μV) | Average Level dB(μV) |
| 150kHz ~ 500kHz | 66 ~ 56* | 56 ~ 46* |
| 500kHz ~ 5MHz | 56 | 46 |
| 5MHz ~ 30MHz | 60 | 50 |

Notes: 1. * Decreasing linearly with logarithm of frequency.

2. The lower limit shall apply at the transition frequencies.

3.4. Configuration of EUT on Test

The following equipment are installed on Power Line Conducted Emission Test to meet the commission requirement and operating regulations in a manner which tends to maximize its emission characteristics in a normal application.

3.4.1. LCD TV (EUT)

Model Number : 48FD2700
Serial Number : N/A

3.4.2. Support Equipment : As Tested Supporting System Detail, in Section 2.2.

3.5. Operating Condition of EUT

3.5.1. Setup the EUT and simulator as shown as Section 3.2.

3.5.2. Turn on the power of all equipment.

3.5.3. PC system ran the Self-test program “EMC Test. exe” by windows XP and sent “H” Character to LCD TV (EUT) , the Screen of EUT displayed and filled with “H” pattern, use white letters on a black ground, set the contrast control to maximum, set the brightness control to maximum and measure it.

3.5.4. The other peripheral devices were driven and operated in turn during all testing.

3.6. Test Procedure

The EUT was placed on a non-metallic table, 80cm above the ground plane. The EUT Power connected to the power mains through a line impedance stabilization network (L.I.S.N. 1#). This provided a 50-ohm coupling impedance for the EUT (Please refer to the block diagram of the test setup and photographs). The other peripheral devices power cord connected to the power mains through a line impedance stabilization network (L.I.S.N.# 3). Both sides of power line were checked for maximum conducted interference. In order to find the maximum emission, the relative positions of equipments and all of the interface cables were changed according to ANSI C63.4: 2009 on conducted Emission test.

The bandwidth of test receiver (R&S TEST RECEIVER ESCI) is set at 9kHz.

The frequency range from 150kHz to 30MHz is checked. The test result are reported on Section 3.7.

3.7. Conducted Emission at Mains Terminals Test Results

PASS. (All emissions not reported below are too low against the prescribed limits.)

The EUT with the following test modes were tested and selected to read Q.P values and average values, all the test results are listed in next pages.

EUT: LCD TV

Model No. : 48FD2700

Test Date: Jun.10, 2015

Temperature: 23°C

Humidity: 52%

The details of test modes are as follows :

| The worst for video test mode | | | | | |
|--|-----------|------------|------------------------|-------------------------|---------|
| No. | Test Mode | Input Port | Resolution & Frequency | Reference Test Data No. | |
| | | | | Line | Neutral |
| The Worst for Video Resolution of original report | | | | | |
| 1. | PC Mode | HDMI 1 | 1920*1080/60Hz | # 26 | # 25 |
| 2. | | HDMI 2 | 1920*1080/60Hz | # 27 | # 28 |
| 3. ※ | | HDMI 3 | 1920*1080/60Hz | # 30 | # 29 |

(※ Worst test mode)

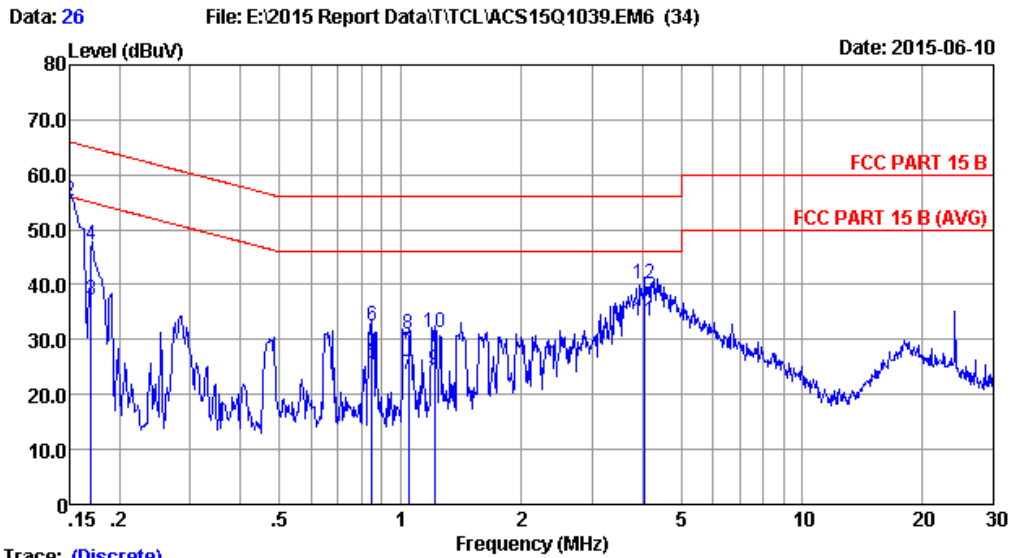

Trace: (Discrete)

Site no :1# Conduction Data No :26
 Dis./Lisn :2014 ESH2-Z5 LINE
 Limit :FCC PART 15 B
 Env./Ins. :23.0*C/52% Engineer :Dendi
 EUT :LCD TV M/N:48FD2700
 Power Rating :AC 120V/60Hz
 Test Mode :Running "H" Pattern And 1kHz Playing
 HDMI 1:1920*1080@60Hz

| No | Freq (MHz) | LISN Factor (dB) | Cable Loss (dB) | Reading (dBuV) | Emission Level (dBuV) | Limits (dBuV) | Margin (dB) | Remark |
|----|------------|------------------|-----------------|----------------|-----------------------|---------------|-------------|---------|
| 1 | 0.150 | 0.14 | 9.92 | 29.50 | 39.56 | 56.00 | 16.44 | Average |
| 2 | 0.150 | 0.14 | 9.92 | 45.10 | 55.16 | 66.00 | 10.84 | QP |
| 3 | 0.170 | 0.14 | 9.92 | 27.20 | 37.26 | 54.96 | 17.70 | Average |
| 4 | 0.170 | 0.14 | 9.92 | 37.30 | 47.36 | 64.96 | 17.60 | QP |
| 5 | 0.848 | 0.15 | 9.95 | 15.71 | 25.81 | 46.00 | 20.19 | Average |
| 6 | 0.848 | 0.15 | 9.95 | 22.36 | 32.46 | 56.00 | 23.54 | QP |
| 7 | 1.049 | 0.16 | 9.96 | 13.40 | 23.52 | 46.00 | 22.48 | Average |
| 8 | 1.049 | 0.16 | 9.96 | 20.82 | 30.94 | 56.00 | 25.06 | QP |
| 9 | 1.216 | 0.16 | 9.96 | 14.30 | 24.42 | 46.00 | 21.58 | Average |
| 10 | 1.216 | 0.16 | 9.96 | 21.24 | 31.36 | 56.00 | 24.64 | QP |
| 11 | 4.070 | 0.23 | 10.05 | 23.20 | 33.48 | 46.00 | 12.52 | Average |
| 12 | 4.070 | 0.23 | 10.05 | 30.00 | 40.28 | 56.00 | 15.72 | QP |

Remarks: 1.Emission Level=LISN Factor+Cable Loss(Include 10dB pulse limit)+Reading.
 2.If the average limit is met when using a quasi-peak detector, the EUT shall be deemed to meet both limits and measurement with average detector is unnecessary.

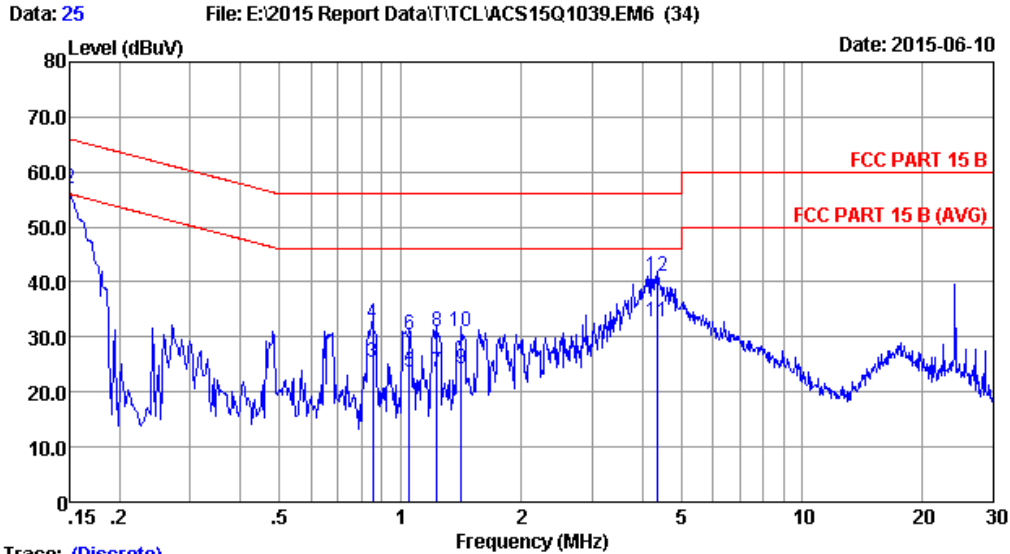

Trace: (Discrete)

Site no :1# Conduction Data No :25
 Dis./Lisn :2014 ESH2-25 NEUTRAL
 Limit :FCC PART 15 B
 Env./Ins. :23.0*C/52% Engineer :Dendi
 EUT :LCD TV M/N:48FD2700
 Power Rating :AC 120V/60Hz
 Test Mode :Running "H" Pattern And 1kHz Playing
 HDMI 1:1920*1080@60Hz

| No | Freq (MHz) | LISN Factor (dB) | Cable Loss (dB) | Reading (dBuV) | Emission Level (dBuV) | Limits (dBuV) | Margin (dB) | Remark |
|----|------------|------------------|-----------------|----------------|-----------------------|---------------|-------------|---------|
| 1 | 0.150 | 0.13 | 9.92 | 28.80 | 38.85 | 56.00 | 17.15 | Average |
| 2 | 0.150 | 0.13 | 9.92 | 47.00 | 57.05 | 66.00 | 8.95 | QP |
| 3 | 0.853 | 0.17 | 9.95 | 15.30 | 25.42 | 46.00 | 20.58 | Average |
| 4 | 0.853 | 0.17 | 9.95 | 22.50 | 32.62 | 56.00 | 23.38 | QP |
| 5 | 1.054 | 0.18 | 9.96 | 13.60 | 23.74 | 46.00 | 22.26 | Average |
| 6 | 1.054 | 0.18 | 9.96 | 20.35 | 30.49 | 56.00 | 25.51 | QP |
| 7 | 1.236 | 0.18 | 9.96 | 13.50 | 23.64 | 46.00 | 22.36 | Average |
| 8 | 1.236 | 0.18 | 9.96 | 20.79 | 30.93 | 56.00 | 25.07 | QP |
| 9 | 1.418 | 0.18 | 9.96 | 14.10 | 24.24 | 46.00 | 21.76 | Average |
| 10 | 1.418 | 0.18 | 9.96 | 20.85 | 30.99 | 56.00 | 25.01 | QP |
| 11 | 4.384 | 0.26 | 10.05 | 22.41 | 32.72 | 46.00 | 13.28 | Average |
| 12 | 4.384 | 0.26 | 10.05 | 30.74 | 41.05 | 56.00 | 14.95 | QP |

Remarks: 1.Emission Level=LISN Factor+Cable Loss(Include 10dB pulse limit)+Reading.
 2.If the average limit is met when using a quasi-peak detector, the EUT shall be deemed to meet both limits and measurement with average detector is unnecessary.

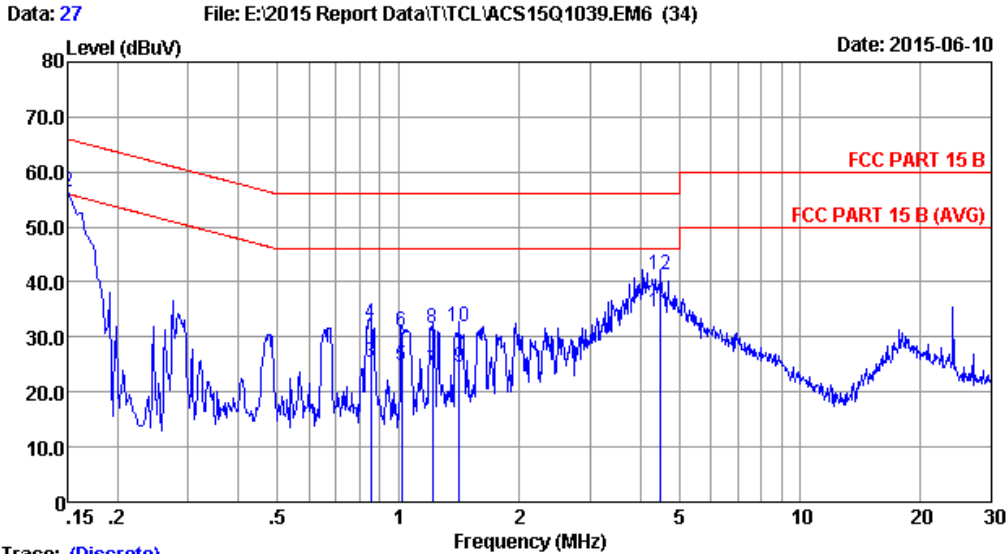

Trace: (Discrete)

Site no :1# Conduction Data No :27
 Dis./Lisn :2014 ESH2-25 LINE
 Limit :FCC PART 15 B
 Env./Ins. :23.0*C/52% Engineer :Dendi
 EUT :LCD TV M/N:48FD2700
 Power Rating :AC 120V/60Hz
 Test Mode :Running "H" Pattern And 1kHz Playing
 HDMI 2:1920*1080@60Hz

| No | Freq (MHz) | LISN Factor (dB) | Cable Loss (dB) | Reading (dBuV) | Emission Level (dBuV) | Limits (dBuV) | Margin (dB) | Remark |
|----|------------|------------------|-----------------|----------------|-----------------------|---------------|-------------|---------|
| 1 | 0.150 | 0.14 | 9.92 | 27.70 | 37.76 | 56.00 | 18.24 | Average |
| 2 | 0.150 | 0.14 | 9.92 | 46.40 | 56.46 | 66.00 | 9.54 | QP |
| 3 | 0.853 | 0.16 | 9.95 | 15.20 | 25.31 | 46.00 | 20.69 | Average |
| 4 | 0.853 | 0.16 | 9.95 | 22.50 | 32.61 | 56.00 | 23.39 | QP |
| 5 | 1.021 | 0.16 | 9.96 | 14.70 | 24.82 | 46.00 | 21.18 | Average |
| 6 | 1.021 | 0.16 | 9.96 | 21.02 | 31.14 | 56.00 | 24.86 | QP |
| 7 | 1.216 | 0.16 | 9.96 | 13.80 | 23.92 | 46.00 | 22.08 | Average |
| 8 | 1.216 | 0.16 | 9.96 | 21.38 | 31.50 | 56.00 | 24.50 | QP |
| 9 | 1.418 | 0.17 | 9.96 | 14.31 | 24.44 | 46.00 | 21.56 | Average |
| 10 | 1.418 | 0.17 | 9.96 | 21.64 | 31.77 | 56.00 | 24.23 | QP |
| 11 | 4.501 | 0.24 | 10.06 | 24.19 | 34.49 | 46.00 | 11.51 | Average |
| 12 | 4.501 | 0.24 | 10.06 | 31.03 | 41.33 | 56.00 | 14.67 | QP |

Remarks: 1.Emission Level=LISN Factor+Cable Loss(Include 10dB pulse limit)+Reading.
 2.If the average limit is met when using a quasi-peak detector, the EUT shall be deemed to meet both limits and measurement with average detector is unnecessary.

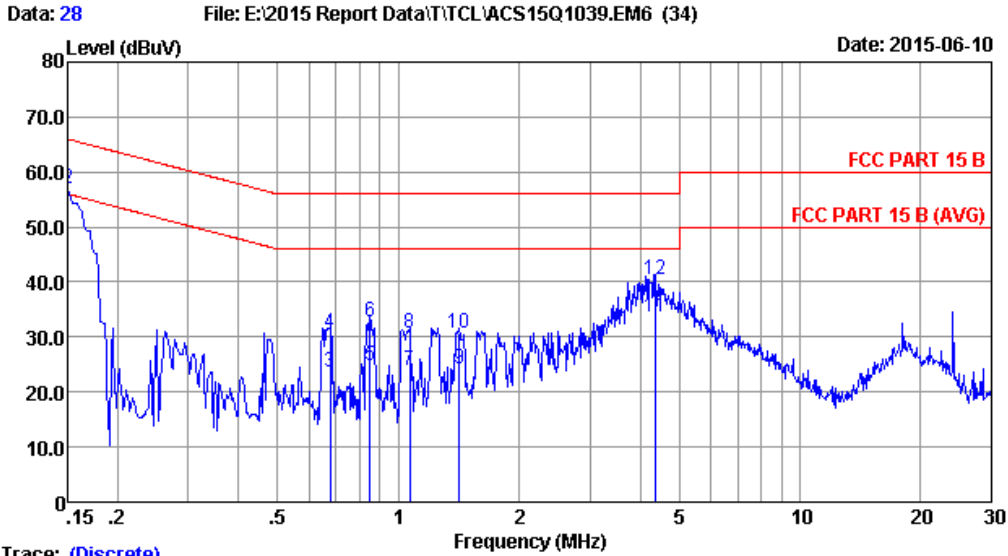

Trace: (Discrete)

Site no :1# Conduction Data No :28
 Dis./Lisn :2014 ESH2-25 NEUTRAL
 Limit :FCC PART 15 B
 Env./Ins. :23.0*C/52% Engineer :Dendi
 EUT :LCD TV M/N:48FD2700
 Power Rating :AC 120V/60Hz
 Test Mode :Running "H" Pattern And 1kHz Playing
 HDMI 2:1920*1080@60Hz

| No | Freq (MHz) | LISN Factor (dB) | Cable Loss (dB) | Reading (dBuV) | Emission Level (dBuV) | Limits (dBuV) | Margin (dB) | Remark |
|----|------------|------------------|-----------------|----------------|-----------------------|---------------|-------------|---------|
| 1 | 0.150 | 0.13 | 9.92 | 27.40 | 37.45 | 56.00 | 18.55 | Average |
| 2 | 0.150 | 0.13 | 9.92 | 46.90 | 56.95 | 66.00 | 9.05 | QP |
| 3 | 0.675 | 0.16 | 9.95 | 13.50 | 23.61 | 46.00 | 22.39 | Average |
| 4 | 0.675 | 0.16 | 9.95 | 20.55 | 30.66 | 56.00 | 25.34 | QP |
| 5 | 0.848 | 0.17 | 9.95 | 14.70 | 24.82 | 46.00 | 21.18 | Average |
| 6 | 0.848 | 0.17 | 9.95 | 22.63 | 32.75 | 56.00 | 23.25 | QP |
| 7 | 1.065 | 0.18 | 9.96 | 13.90 | 24.04 | 46.00 | 21.96 | Average |
| 8 | 1.065 | 0.18 | 9.96 | 20.69 | 30.83 | 56.00 | 25.17 | QP |
| 9 | 1.418 | 0.18 | 9.96 | 14.20 | 24.34 | 46.00 | 21.66 | Average |
| 10 | 1.418 | 0.18 | 9.96 | 20.49 | 30.63 | 56.00 | 25.37 | QP |
| 11 | 4.384 | 0.26 | 10.05 | 23.31 | 33.62 | 46.00 | 12.38 | Average |
| 12 | 4.384 | 0.26 | 10.05 | 30.08 | 40.39 | 56.00 | 15.61 | QP |

Remarks: 1.Emission Level=LISN Factor+Cable Loss(Include 10dB pulse limit)+Reading.
 2.If the average limit is met when using a quasi-peak detector, the EUT shall be deemed to meet both limits and measurement with average detector is unnecessary.

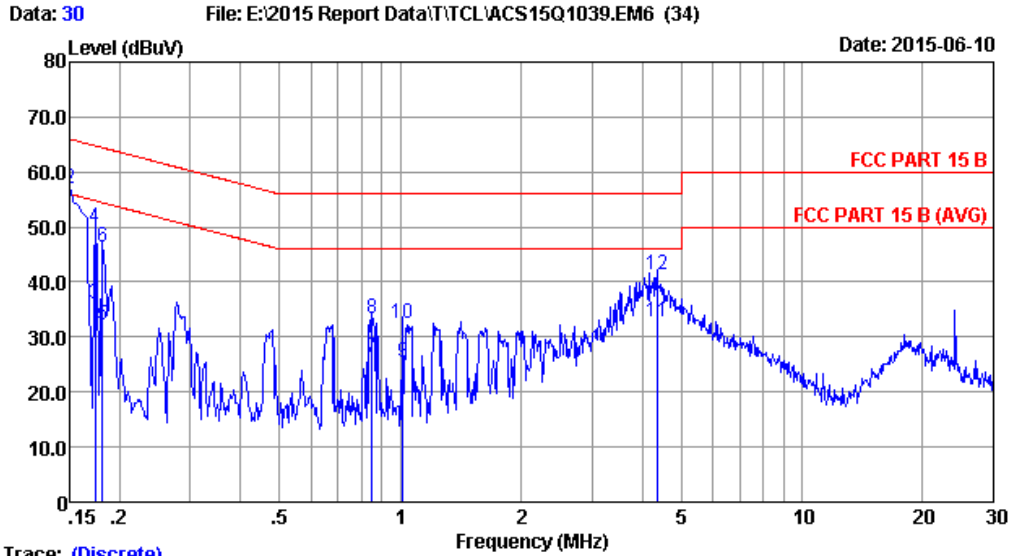

Trace: (Discrete)

Site no :1# Conduction Data No :30
 Dis./Lisn :2014 ESH2-25 LINE
 Limit :FCC PART 15 B
 Env./Ins. :23.0*C/52% Engineer :Dendi
 EUT :LCD TV M/N:48FD2700
 Power Rating :AC 120V/60Hz
 Test Mode :Running "H" Pattern And 1kHz Playing
 HDMI 3:1920*1080@60Hz

| No | Freq (MHz) | LISN Factor (dB) | Cable Loss (dB) | Reading (dBUV) | Emission Level (dBUV) | Limits (dBUV) | Margin (dB) | Remark |
|----|------------|------------------|-----------------|----------------|-----------------------|---------------|-------------|---------|
| 1 | 0.150 | 0.14 | 9.92 | 27.20 | 37.26 | 56.00 | 18.74 | Average |
| 2 | 0.150 | 0.14 | 9.92 | 47.00 | 57.06 | 66.00 | 8.94 | QP |
| 3 | 0.174 | 0.14 | 9.93 | 25.89 | 35.96 | 54.77 | 18.81 | Average |
| 4 | 0.174 | 0.14 | 9.93 | 39.96 | 50.03 | 64.77 | 14.74 | QP |
| 5 | 0.182 | 0.14 | 9.93 | 22.09 | 32.16 | 54.42 | 22.26 | Average |
| 6 | 0.182 | 0.14 | 9.93 | 36.30 | 46.37 | 64.42 | 18.05 | QP |
| 7 | 0.848 | 0.15 | 9.95 | 16.31 | 26.41 | 46.00 | 19.59 | Average |
| 8 | 0.848 | 0.15 | 9.95 | 23.30 | 33.40 | 56.00 | 22.60 | QP |
| 9 | 1.016 | 0.16 | 9.96 | 15.40 | 25.52 | 46.00 | 20.48 | Average |
| 10 | 1.016 | 0.16 | 9.96 | 22.47 | 32.59 | 56.00 | 23.41 | QP |
| 11 | 4.361 | 0.23 | 10.05 | 22.41 | 32.69 | 46.00 | 13.31 | Average |
| 12 | 4.361 | 0.23 | 10.05 | 30.93 | 41.21 | 56.00 | 14.79 | QP |

Remarks: 1.Emission Level=LISN Factor+Cable Loss(Include 10dB pulse limit)+Reading.
 2.If the average limit is met when using a quasi-peak detector, the EUT shall be deemed to meet both limits and measurement with average detector is unnecessary.

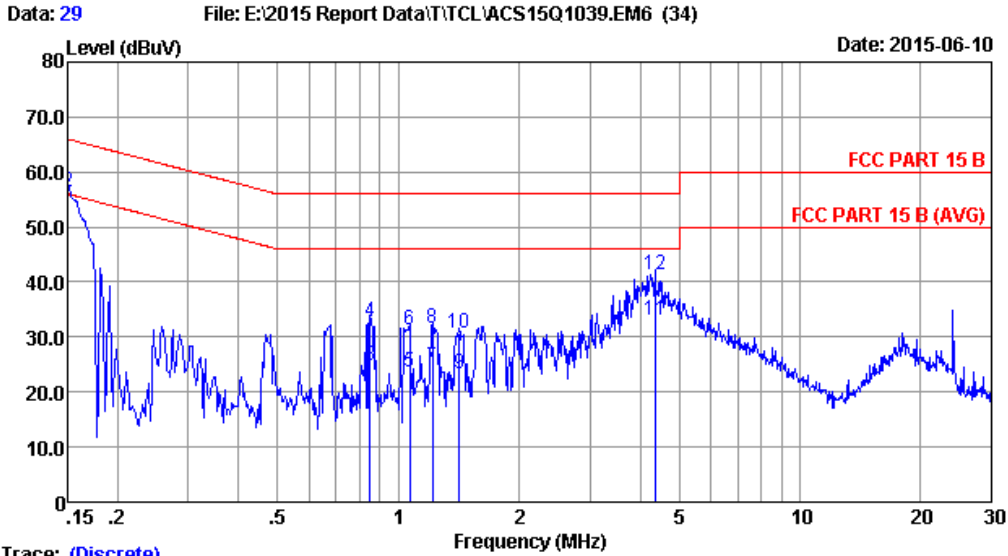

Trace: (Discrete)
 Site no :1# Conduction Data No :29
 Dis./Lisn :2014 ESH2-25 NEUTRAL
 Limit :FCC PART 15 B
 Env./Ins. :23.0*C/52% Engineer :Dendi
 EUT :LCD TV M/N:48FD2700
 Power Rating :AC 120V/60Hz
 Test Mode :Running "H" Pattern And 1kHz Playing
 HDMI 3:1920*1080@60Hz

| No | Freq (MHz) | LISN Factor (dB) | Cable Loss (dB) | Reading (dBuV) | Emission Level (dBuV) | Limits (dBuV) | Margin (dB) | Remark |
|----|------------|------------------|-----------------|----------------|-----------------------|---------------|-------------|---------|
| 1 | 0.150 | 0.13 | 9.92 | 27.60 | 37.65 | 56.00 | 18.35 | Average |
| 2 | 0.150 | 0.13 | 9.92 | 46.20 | 56.25 | 66.00 | 9.75 | QP |
| 3 | 0.848 | 0.17 | 9.95 | 14.70 | 24.82 | 46.00 | 21.18 | Average |
| 4 | 0.848 | 0.17 | 9.95 | 22.70 | 32.82 | 56.00 | 23.18 | QP |
| 5 | 1.065 | 0.18 | 9.96 | 13.40 | 23.54 | 46.00 | 22.46 | Average |
| 6 | 1.065 | 0.18 | 9.96 | 21.29 | 31.43 | 56.00 | 24.57 | QP |
| 7 | 1.216 | 0.18 | 9.96 | 14.30 | 24.44 | 46.00 | 21.56 | Average |
| 8 | 1.216 | 0.18 | 9.96 | 21.47 | 31.61 | 56.00 | 24.39 | QP |
| 9 | 1.418 | 0.18 | 9.96 | 13.20 | 23.34 | 46.00 | 22.66 | Average |
| 10 | 1.418 | 0.18 | 9.96 | 20.47 | 30.61 | 56.00 | 25.39 | QP |
| 11 | 4.361 | 0.26 | 10.05 | 22.71 | 33.02 | 46.00 | 12.98 | Average |
| 12 | 4.361 | 0.26 | 10.05 | 30.98 | 41.29 | 56.00 | 14.71 | QP |

Remarks: 1.Emission Level=LISN Factor+Cable Loss(Include 10dB pulse limit)+Reading.
 2.If the average limit is met when using a quasi-peak detector, the EUT shall be deemed to meet both limits and measurement with average detector is unnecessary.

4. RADIATED EMISSION MEASUREMENT

4.1. Test Equipment

4.1.1. For frequency range 30MHz~1000MHz

| Item | Equipment | Manufacturer | Model No. | Serial No. | Last Cal. | Cal. Interval |
|------|--------------------------------|-------------------|---------------------|---------------------|-----------|---------------|
| 1. | 3#Chamber | AUDIX | N/A | N/A | Nov.23,14 | 1 Year |
| 2. | EMI Spectrum | Agilent | E4407B | MY41440292 | Apr.28,15 | 1 Year |
| 3. | Test Receiver | Rohde & Schwarz | ESVS10 | 834468/011 | Apr.28,15 | 1 Year |
| 4. | Amplifier | HP | 8447D | 2648A04738 | Apr.28,15 | 1 Year |
| 5. | Bilog Antenna | TESEQ | CBL6112D | 35375 | Jun.18,14 | 1 Year |
| 6. | RF Cable | MIYAZAKI | CFD400-N W(3.5M) | 3# Chamber No.3 | Apr.28,15 | 1 Year |
| 7. | RF Cable | MIYAZAKI | CFD400-L W(22M) | 3# Chamber No.7 | Apr.28,15 | 1 Year |
| 8. | Coaxial Switch | Anritsu | MP59B | 6201397222 | Apr.28,15 | 1 Year |
| 9. | MPEG2 Measurement Generator | ROHDE&SCHWA RZ | DVG | 100319 | Oct.29,14 | 1 Year |
| 10. | TV Transmitter | ROHDE&SCHWA RZ | SFQ | 100521 | Apr.28,15 | 1 Year |
| 11. | Signal Generator | HP | 8648A | 3625U00573 | Apr.28,15 | 1 Year |
| 12. | Pattern Generator | Philips | PM5418 | LO625020 | Apr.28,15 | 1 Year |
| 13. | Test Software | AUDIX | E3 | 6.2009-5-21a(n) | N/A | N/A |

4.1.2. For frequency range 1GHz~18GHz

| Item | Equipment | Manufacturer | Model No. | Serial No. | Last Cal. | Cal. Interval |
|------|--------------------------------|-------------------|-------------|----------------------|-----------|---------------|
| 1. | 3#Chamber | AUDIX | N/A | N/A | Nov.02,14 | 1 Year |
| 2. | Spectrum Analyzer | Agilent | E4407B | MY41440292 | Apr.28,15 | 1 Year |
| 3. | Horn Antenna | ETC | MCTD 1209 | DRH15F03006 | Feb.03,15 | 1 Year |
| 4. | Horn Antenna | ETS | 3115 | 9510-4877 | Sep.20,14 | 1 Year |
| 5. | Amplifier | Agilent | 83017A | MY53270084 | May.25,15 | 1 Year |
| 6. | RF Cable | Hubersuhner | SUCOFLEX106 | 505238/6+2861 6/2 | Apr.28,15 | 1 Year |
| 7. | MPEG2 Measurement Generator | ROHDE&SC HWARZ | DVG | 100319 | Oct.29,14 | 1 Year |
| 8. | TV Transmitter | ROHDE&SC HWARZ | SFQ | 100521 | Apr.28,15 | 1 Year |
| 9. | Pattern Generator | Philips | PM5418 | LO625020 | Apr.28,15 | 1 Year |
| 10. | Test Software | AUDIX | E3 | 6.2009-5-21a(n) | N/A | N/A |

4.2. Block Diagram of Test Setup

4.2.1. For frequency range 30MHz-1000MHz

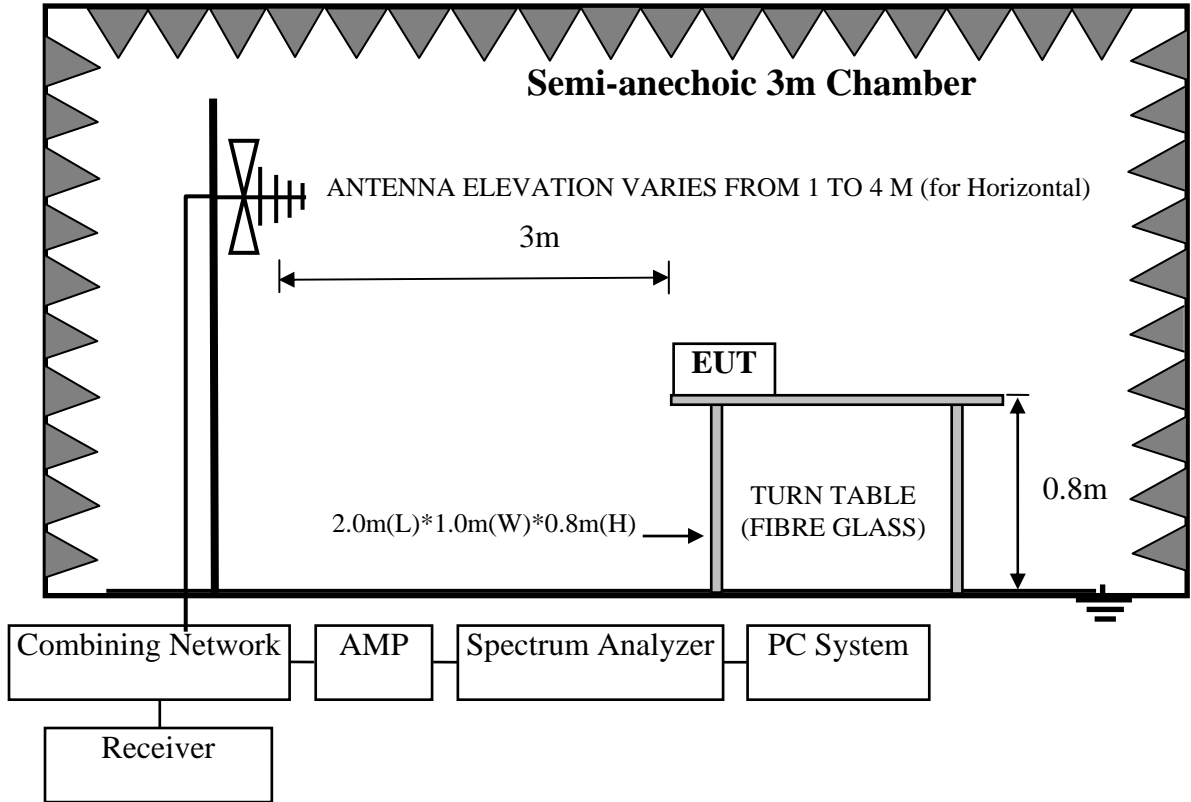

4.2.2. For frequency range 1GHz-18GHz

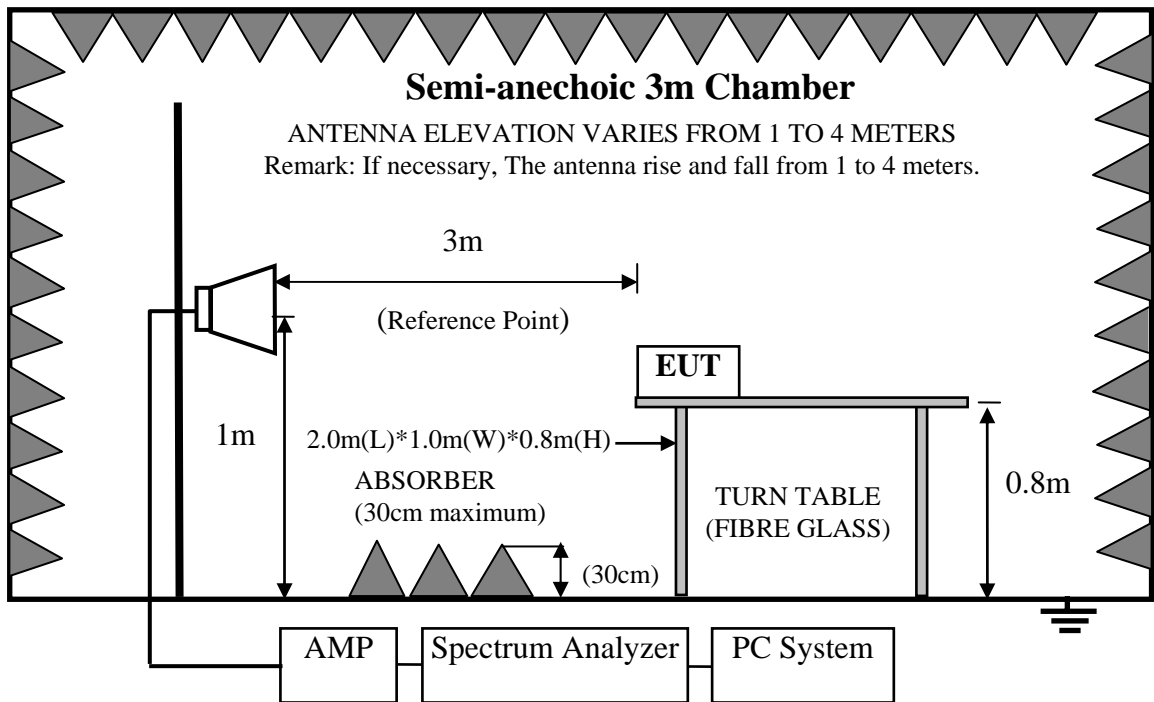

4.3. Radiated Emission Limit

| Frequency MHz | Distance (Meters) | Field Strengths Limits dB(μV)/m |
|------------------|----------------------|------------------------------------|
| 30 ~ 88 | 3 | 40.0 |
| 88 ~ 216 | 3 | 43.5 |
| 216 ~ 960 | 3 | 46.0 |
| 960 ~ 1000 | 3 | 54.0 |
| Above 1000 | 3 | 74(Peak)54(Average) |

- Remark: (1) Emission level = Antenna Factor + Cable Loss + Reading
Emission level = Antenna Factor - Amp Factor + Cable Loss + Reading
(above 1000MHz)
- (2) The smaller limit shall apply at the cross point between two frequency bands.
- (3) Distance is the distance in meters between the measuring instrument, antenna and the closest point of any part of the device or system.

4.4. EUT Configuration on Test

The configurations of EUT are listed in Section 3.4

4.5. Operating Condition of EUT

Same as Conducted Emission test that is listed in Section 3.5. except the test set up replaced by Section 4.2.

4.6. Test Procedure

The EUT was placed on a non-metallic table, 80 cm above the ground plane inside a semi-anechoic chamber. An antenna was located 3m from the EUT on an adjustable mast. A pre-scan was first performed in order to find prominent radiated emissions. For final emissions measurements at each frequency of interest, the EUT were rotated and the antenna height was varied between 1m and 4m in order to maximize the emission. Measurements in both horizontal and vertical polarities were made and the data was recorded. In order to find the maximum emission, the relative positions of equipments and all of the interface cables were changed according to ANSI C63.4: 2009 on Radiated Emission test.

The bandwidth of the EMI test receiver (R&S ESVS10) is set at 120kHz for frequency range from 30MHz to 1000 MHz.

The bandwidth of the Spectrum's RBW is set at 1MHz and VBW is set at 3MHz for peak emissions measurement above 1GHz and 1MHz RBW, 10Hz VBW for average emissions measure above 1GHz.

4.7. Radiated Emission Test Results

PASS. (All emissions not reported below are too low against the prescribed limits.)

EUT: LCD TV

Model No. : 48FD2700

For frequency range 30MHz~1000MHz

The EUT with the following test modes were tested and selected to read Q.P values, all the test results are listed in next pages.

Test Date: Jun.11, 2015

Temperature: 24°C

Humidity: 56%

The details of test modes are as follows :

| The worst for video test mode | | | | | |
|--|-----------|------------|------------------------|-------------------------|----------|
| No. | Test Mode | Input Port | Resolution & Frequency | Reference Test Data No. | |
| | | | | Horizontal | Vertical |
| The Worst for Video Resolution of original report | | | | | |
| 1. | PC Mode | HDMI 1 | 1920*1080/60Hz | # 25 | # 26 |
| 2. ※ | | HDMI 2 | 1920*1080/60Hz | # 28 | # 27 |
| 3. | | HDMI 3 | 1920*1080/60Hz | # 29 | # 30 |

(※ Worst test mode)

For frequency range 1GHz~5GHz

The EUT with below test mode were measured within Anechoic Chamber and the test results listed in next pages

Note: For all the emissions above 1GHz, the peak measured level comply with peak limit, so the average level were deemed to comply with average limit.

Test Date: Jun.11, 2015

Temperature: 24°C

Humidity: 56%

| The worst for video test mode | | | | | |
|--|-----------|------------|------------------------|-------------------------|----------|
| No. | Test Mode | Input Port | Resolution & Frequency | Reference Test Data No. | |
| | | | | Horizontal | Vertical |
| The Worst for Video Resolution of original report | | | | | |
| 1. | PC Mode | HDMI 1 | 1920*1080/60Hz | # 41 | # 42 |
| 2. | | HDMI 2 | 1920*1080/60Hz | # 44 | # 43 |
| 3. ※ | | HDMI 3 | 1920*1080/60Hz | # 45 | # 46 |

(※ Worst test mode)

30MHz~1000MHz

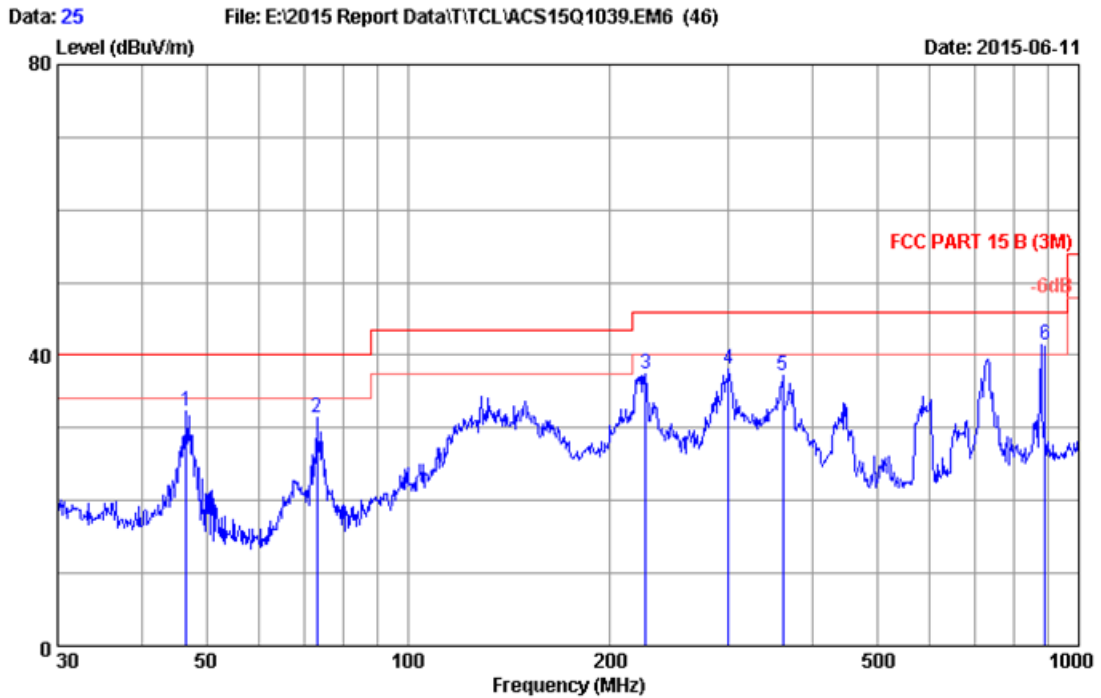

Site no. : 3m Chamber Data no. : 25
 Dis. / Ant. : 3m 2014 CBL6112D 35375 Ant. pol. : HORIZONTAL
 Limit : FCC PART 15 B (3M)
 Env. / Ins. : 24°C/56% Engineer : Donjon
 EUT : LCD TV M/N:48FD2700
 Power rating : AC 120V/60Hz
 Test Mode : PC Mode
 Running "H" Pattern And 1KHz Playing
 HDMI 1:1920*1080@60Hz

| No. | Freq. (MHz) | Ant. Factor (dB/m) | Cable Loss (dB) | Reading (dBuV) | Emission Level (dBuV/m) | Limits (dBuV/m) | Margin (dB) | Remark |
|-----|-------------|--------------------|-----------------|----------------|-------------------------|-----------------|-------------|--------|
| 1 | 46.67 | 9.97 | 0.81 | 21.59 | 32.37 | 40.00 | 7.63 | QP |
| 2 | 73.10 | 6.90 | 0.93 | 23.52 | 31.35 | 40.00 | 8.65 | QP |
| 3 | 226.10 | 11.00 | 1.60 | 24.93 | 37.53 | 46.00 | 8.47 | QP |
| 4 | 300.37 | 14.01 | 1.90 | 22.26 | 38.17 | 46.00 | 7.83 | QP |
| 5 | 361.71 | 15.73 | 2.10 | 19.28 | 37.11 | 46.00 | 8.89 | QP |
| 6 | 891.05 | 21.72 | 3.47 | 16.30 | 41.49 | 46.00 | 4.51 | QP |

Remarks: 1. Emission Level= Antenna Factor + Cable Loss + Reading.
 2. The emission levels that are 20dB below the official limit are not reported.

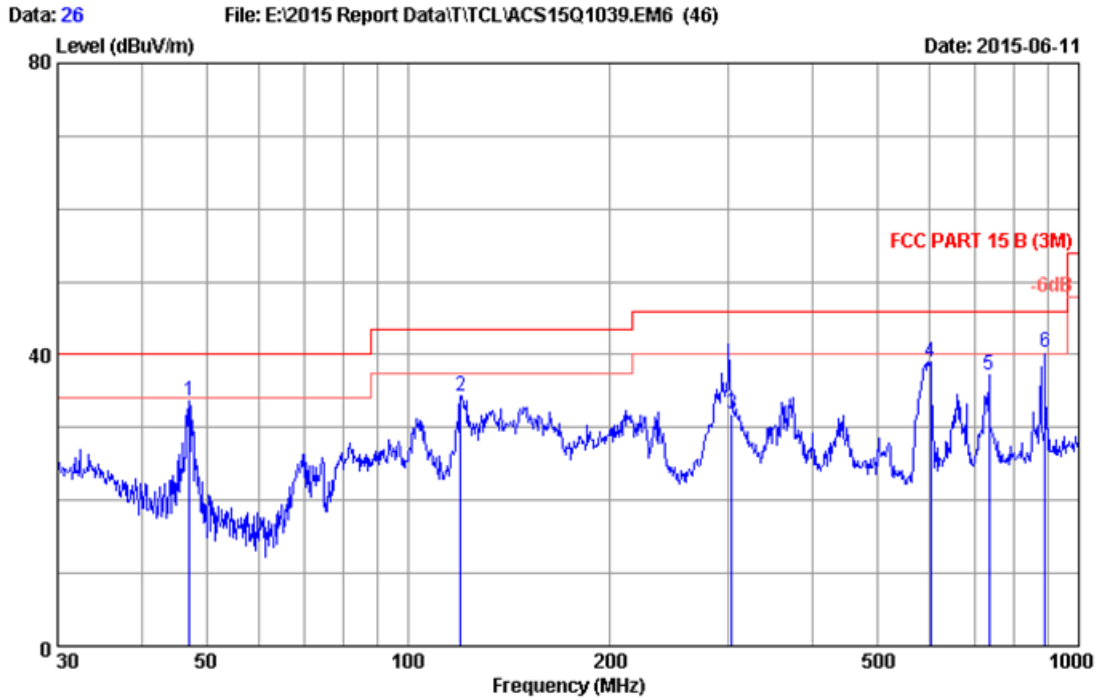

Site no. : 3m Chamber Data no. : 26
 Dis. / Ant. : 3m 2014 CBL6112D 35375 Ant. pol. : VERTICAL
 Limit : FCC PART 15 B (3M)
 Env. / Ins. : 24°C/56% Engineer : Donjon
 EUT : LCD TV M/N:48FD2700
 Power rating : AC 120V/60Hz
 Test Mode : PC Mode
 Running "H" Pattern And 1KHz Playing
 HDMI 1:1920*1080@60Hz

| No. | Freq. (MHz) | Ant. Factor (dB/m) | Cable Loss (dB) | Reading (dBuV) | Emission Level (dBuV/m) | Limits (dBuV/m) | Margin (dB) | Remark |
|-----|-------------|--------------------|-----------------|----------------|-------------------------|-----------------|-------------|--------|
| 1 | 47.16 | 9.79 | 0.81 | 22.95 | 33.55 | 40.00 | 6.45 | QP |
| 2 | 119.86 | 12.70 | 1.18 | 20.40 | 34.28 | 43.50 | 9.22 | QP |
| 3 | 303.83 | 14.08 | 1.90 | 15.80 | 31.78 | 46.00 | 14.22 | QP |
| 4 | 601.43 | 19.23 | 2.77 | 16.99 | 38.99 | 46.00 | 7.01 | QP |
| 5 | 734.49 | 20.49 | 3.10 | 13.55 | 37.14 | 46.00 | 8.86 | QP |
| 6 | 891.32 | 21.73 | 3.47 | 15.03 | 40.23 | 46.00 | 5.77 | QP |

Remarks: 1. Emission Level= Antenna Factor + Cable Loss + Reading.
 2. The emission levels that are 20dB below the official limit are not reported.

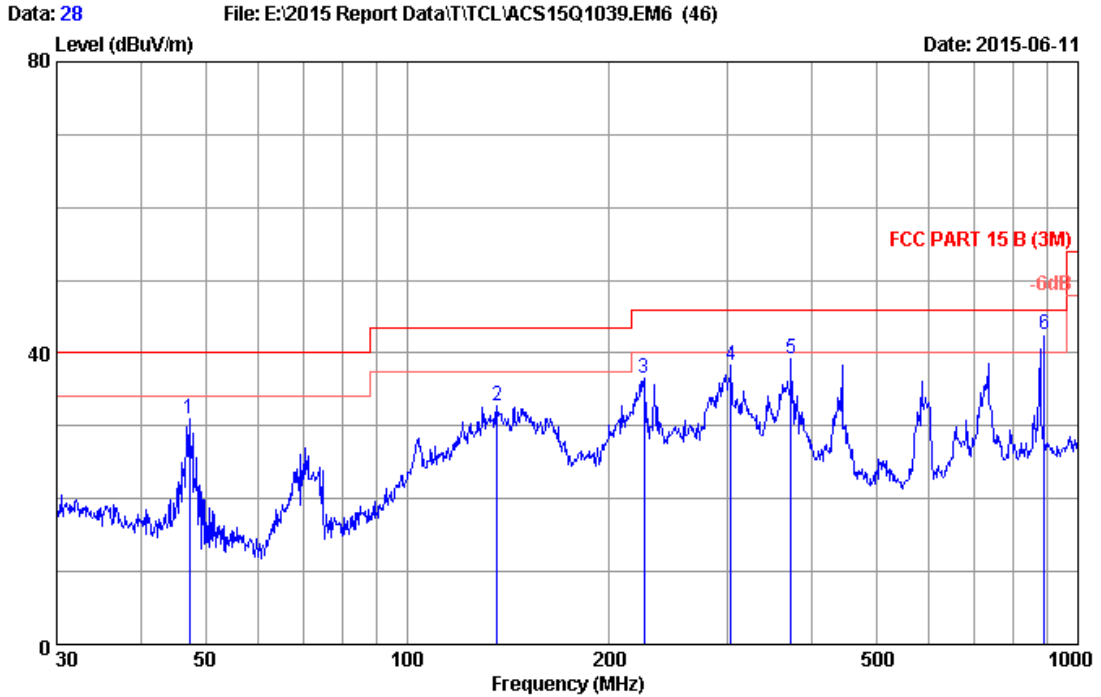

Site no. : 3m Chamber Data no. : 28
 Dis. / Ant. : 3m 2014 CBL6112D 35375 Ant. pol. : HORIZONTAL
 Limit : FCC PART 15 B (3M)
 Env. / Ins. : 24°C/56% Engineer : Donjon
 EUT : LCD TV M/N:48FD2700
 Power rating : AC 120V/60Hz
 Test Mode : PC Mode
 Running "H" Pattern And 1KHz Playing
 HDMI 2:1920*1080@60Hz

| No. | Freq. (MHz) | Ant. Factor (dB/m) | Cable Loss (dB) | Reading (dBuV) | Emission Level (dBuV/m) | Limits (dBuV/m) | Margin (dB) | Remark |
|-----|-------------|--------------------|-----------------|----------------|-------------------------|-----------------|-------------|--------|
| 1 | 47.33 | 9.74 | 0.81 | 20.53 | 31.08 | 40.00 | 8.92 | QP |
| 2 | 135.98 | 12.30 | 1.24 | 19.22 | 32.76 | 43.50 | 10.74 | QP |
| 3 | 225.31 | 10.97 | 1.60 | 23.99 | 36.56 | 46.00 | 9.44 | QP |
| 4 | 303.54 | 14.07 | 1.90 | 22.38 | 38.35 | 46.00 | 7.65 | QP |
| 5 | 373.31 | 15.77 | 2.12 | 21.30 | 39.19 | 46.00 | 6.81 | QP |
| 6 | 891.05 | 21.72 | 3.47 | 44.56 | 42.54 | 46.00 | 3.46 | QP |

Remarks: 1. Emission Level= Antenna Factor + Cable Loss + Reading.
 2. The emission levels that are 20dB below the official limit are not reported.
 3. The worst emission was detected at 891.05 MHz with corrected signal level of 42.54 dB μ V/m (Limit is 46.00 dB μ V/m) when the antenna was at horizontal polarization and at 1.0m high and the turn table was at 75°.
 4. 0° was the table front facing the antenna. Degree is calculated from 0° clockwise facing the antenna.

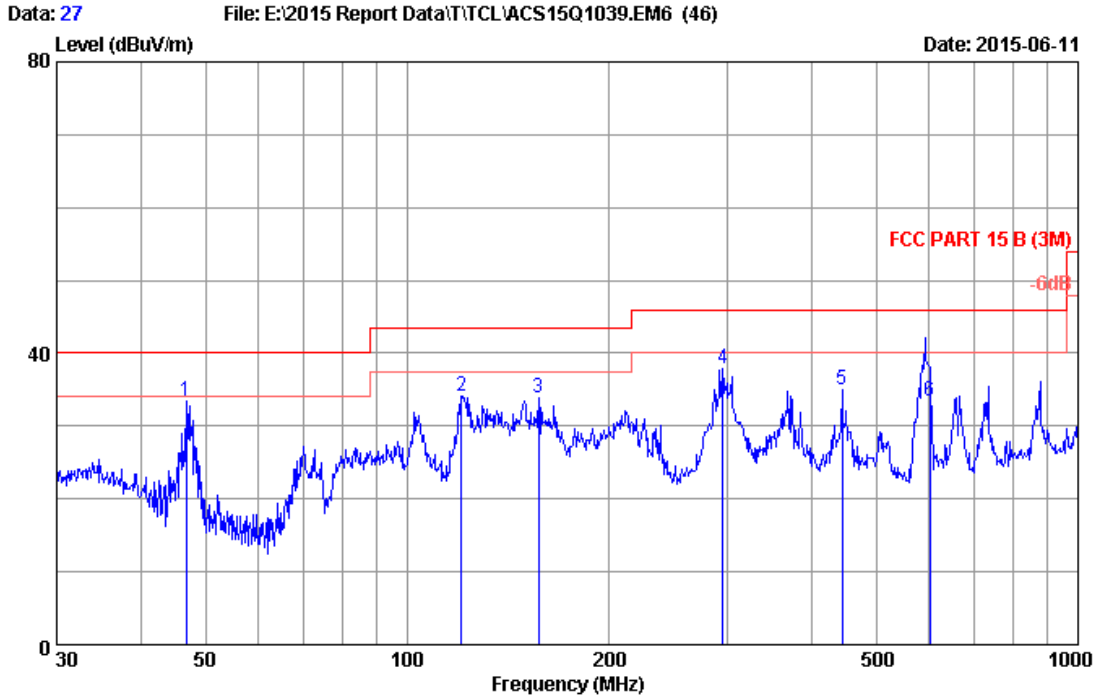

Site no. : 3m Chamber Data no. : 27
 Dis. / Ant. : 3m 2014 CBL6112D 35375 Ant. pol. : VERTICAL
 Limit : FCC PART 15 B (3M)
 Env. / Ins. : 24°C/56% Engineer : Donjon
 EUT : LCD TV M/N:48FD2700
 Power rating : AC 120V/60Hz
 Test Mode : PC Mode
 Running "H" Pattern And 1KHz Playing
 HDMI 2:1920*1080@60Hz

| No. | Freq. (MHz) | Ant. Factor (dB/m) | Cable Loss (dB) | Reading (dBuV) | Emission Level (dBuV/m) | Limits (dBuV/m) | Margin (dB) | Remark |
|-----|-------------|--------------------|-----------------|----------------|-------------------------|-----------------|-------------|--------|
| 1 | 46.83 | 9.91 | 0.81 | 22.75 | 33.47 | 40.00 | 6.53 | QP |
| 2 | 120.28 | 12.71 | 1.18 | 20.20 | 34.09 | 43.50 | 9.41 | QP |
| 3 | 157.01 | 11.00 | 1.32 | 21.64 | 33.96 | 43.50 | 9.54 | QP |
| 4 | 295.15 | 13.86 | 1.87 | 22.19 | 37.92 | 46.00 | 8.08 | QP |
| 5 | 444.85 | 17.20 | 2.36 | 15.40 | 34.96 | 46.00 | 11.04 | QP |
| 6 | 601.85 | 19.24 | 2.77 | 11.50 | 33.51 | 46.00 | 12.49 | QP |

Remarks: 1. Emission Level= Antenna Factor + Cable Loss + Reading.
 2. The emission levels that are 20dB below the official limit are not reported.
 3. The worst emission was detected at 46.83 MHz with corrected signal level of 33.47 dB μ V/m (Limit is 40.00 dB μ V/m) when the antenna was at horizontal polarization and at 1.0m high and the turn table was at 75°.
 4. 0° was the table front facing the antenna. Degree is calculated from 0° clockwise facing the antenna.

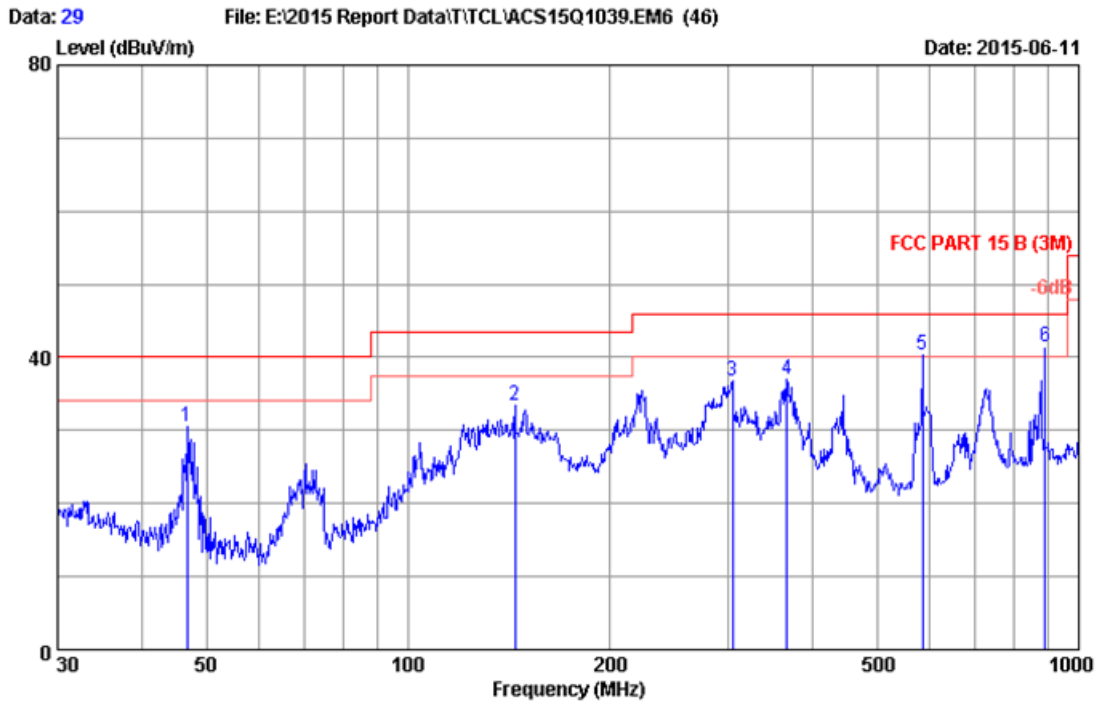

Site no. : 3m Chamber Data no. : 29
 Dis. / Ant. : 3m 2014 CBL6112D 35375 Ant. pol. : HORIZONTAL
 Limit : FCC PART 15 B (3M)
 Env. / Ins. : 24°C/56% Engineer : Donjon
 EUT : LCD TV M/N:48FD2700
 Power rating : AC 120V/60Hz
 Test Mode : PC Mode
 Running "H" Pattern And 1KHz Playing
 HDMI 3:1920*1080@60Hz

| No. | Freq. (MHz) | Ant. Factor (dB/m) | Cable Loss (dB) | Reading (dBuV) | Emission Level (dBuV/m) | Limits (dBuV/m) | Margin (dB) | Remark |
|-----|-------------|--------------------|-----------------|----------------|-------------------------|-----------------|-------------|--------|
| 1 | 46.83 | 9.91 | 0.81 | 19.82 | 30.54 | 40.00 | 9.46 | QP |
| 2 | 144.33 | 11.58 | 1.29 | 20.65 | 33.52 | 43.50 | 9.98 | QP |
| 3 | 304.61 | 14.09 | 1.92 | 20.78 | 36.79 | 46.00 | 9.21 | QP |
| 4 | 366.82 | 15.64 | 2.10 | 19.22 | 36.96 | 46.00 | 9.04 | QP |
| 5 | 584.79 | 19.20 | 2.74 | 18.48 | 40.42 | 46.00 | 5.58 | QP |
| 6 | 891.05 | 21.72 | 3.47 | 16.19 | 41.38 | 46.00 | 4.62 | QP |

Remarks: 1. Emission Level= Antenna Factor + Cable Loss + Reading.
 2. The emission levels that are 20dB below the official limit are not reported.

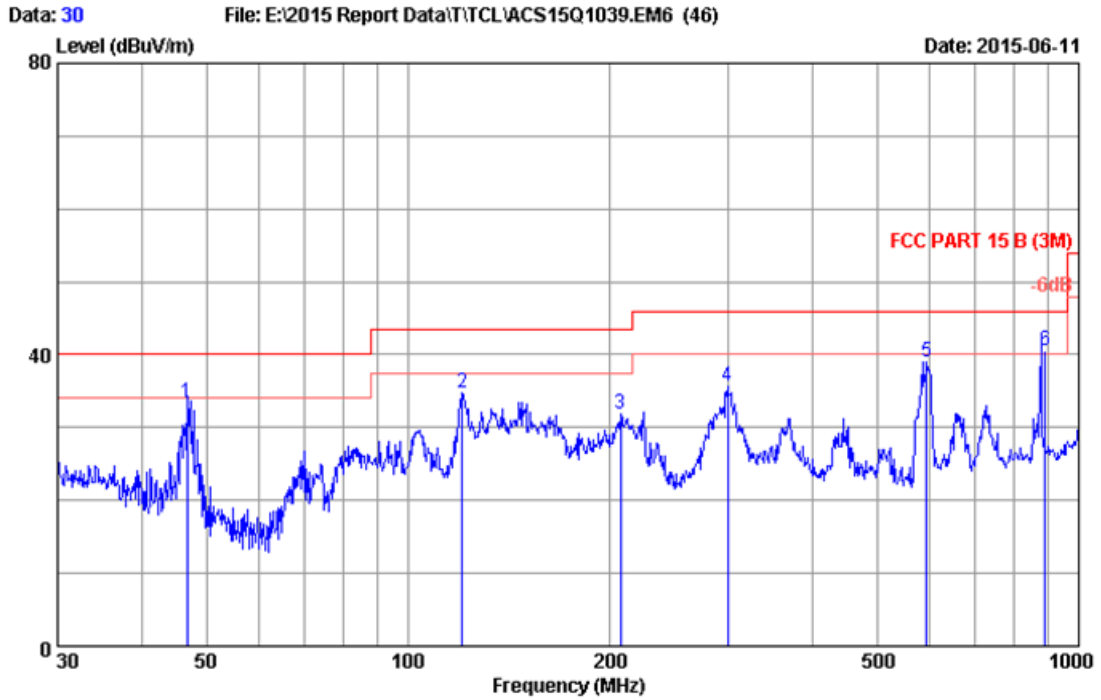

Site no. : 3m Chamber Data no. : 30
 Dis. / Ant. : 3m 2014 CBL6112D 35375 Ant. pol. : VERTICAL
 Limit : FCC PART 15 B (3M)
 Env. / Ins. : 24°C/56% Engineer : Donjon
 EUT : LCD TV M/N:48FD2700
 Power rating : AC 120V/60Hz
 Test Mode : PC Mode
 Running "H" Pattern And 1KHz Playing
 HDMI 3:1920*1080@60Hz

| No. | Freq. (MHz) | Ant. Factor (dB/m) | Cable Loss (dB) | Reading (dBuV) | Emission Level (dBuV/m) | Limits (dBuV/m) | Margin (dB) | Remark |
|-----|-------------|--------------------|-----------------|----------------|-------------------------|-----------------|-------------|--------|
| 1 | 46.83 | 9.91 | 0.81 | 22.70 | 33.42 | 40.00 | 6.58 | QP |
| 2 | 120.28 | 12.71 | 1.18 | 20.76 | 34.65 | 43.50 | 8.85 | QP |
| 3 | 207.12 | 10.60 | 1.54 | 19.75 | 31.89 | 43.50 | 11.61 | QP |
| 4 | 299.32 | 13.97 | 1.90 | 19.81 | 35.68 | 46.00 | 10.32 | QP |
| 5 | 593.05 | 19.20 | 2.75 | 17.08 | 39.03 | 46.00 | 6.97 | QP |
| 6 | 891.32 | 21.73 | 3.47 | 15.38 | 40.58 | 46.00 | 5.42 | QP |

Remarks: 1. Emission Level= Antenna Factor + Cable Loss + Reading.
 2. The emission levels that are 20dB below the official limit are not reported.

1GHz~5GHz

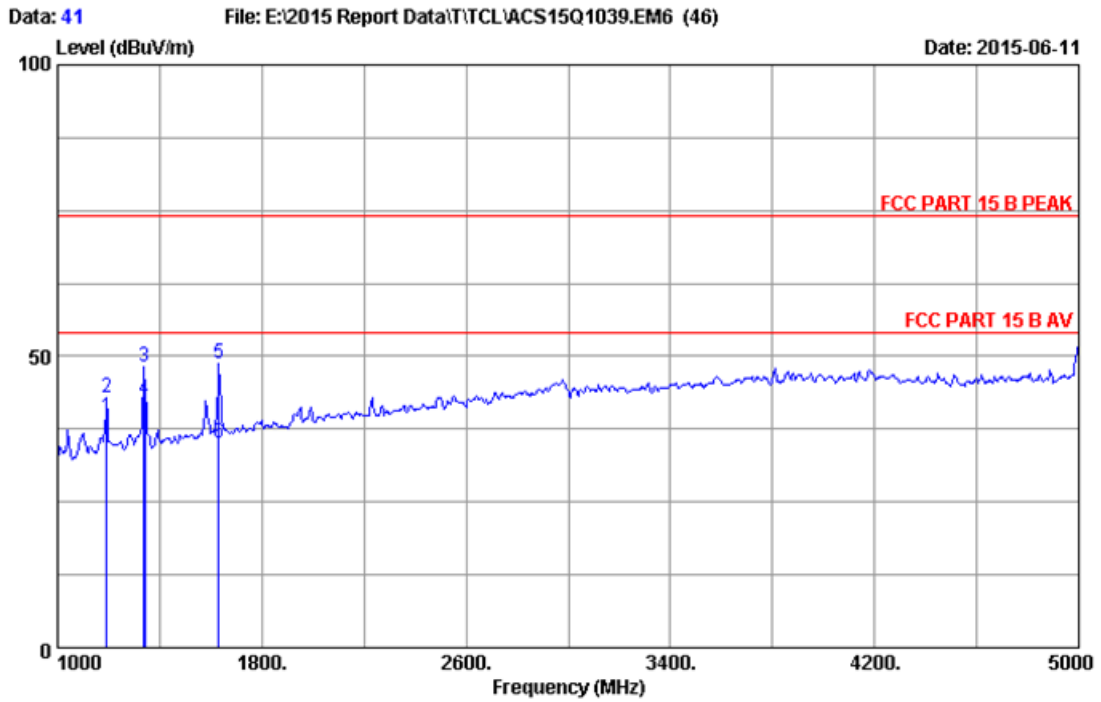

Site no. : 3m Chamber Data no. : 41
 Dis. / Ant. : 3m 2014 3115 9607-4877 Ant. pol. : HORIZONTAL
 Limit : FCC PART 15 B PEAK
 Env. / Ins. : 24°C/56% Engineer : Donjon
 EUT : LCD TV M/N:48FD2700
 Power rating : AC 120V/60Hz
 Test Mode : PC Mode
 : Running"H"Pattern And 1KHz Playing
 HDMI 1:1920*1080@60Hz

| No. | Freq. (MHz) | Ant. Factor (dB/m) | Cable Loss (dB) | Amp factor (dB) | Reading (dBuV) | Emission Level (dBuV/m) | Limits (dBuV/m) | Margin (dB) | Remark |
|-----|-------------|--------------------|-----------------|-----------------|----------------|-------------------------|-----------------|-------------|---------|
| 1 | 1191.56 | 24.58 | 1.94 | 36.72 | 49.87 | 39.67 | 54.00 | 14.33 | Average |
| 2 | 1192.00 | 24.58 | 1.94 | 36.72 | 53.17 | 42.97 | 74.00 | 31.03 | Peak |
| 3 | 1340.00 | 25.30 | 2.18 | 36.28 | 57.00 | 48.20 | 74.00 | 25.80 | Peak |
| 4 | 1341.25 | 25.31 | 2.18 | 36.28 | 51.37 | 42.58 | 54.00 | 11.42 | Average |
| 5 | 1632.00 | 26.47 | 2.51 | 35.22 | 55.02 | 48.78 | 74.00 | 25.22 | Peak |
| 6 | 1632.54 | 26.47 | 2.51 | 35.22 | 41.22 | 34.98 | 54.00 | 19.02 | Average |

Remarks: 1. Emission Level= Antenna Factor + Cable Loss + Reading -Amp factor.
 2. The emission levels that are 20dB below the official limit are not reported.

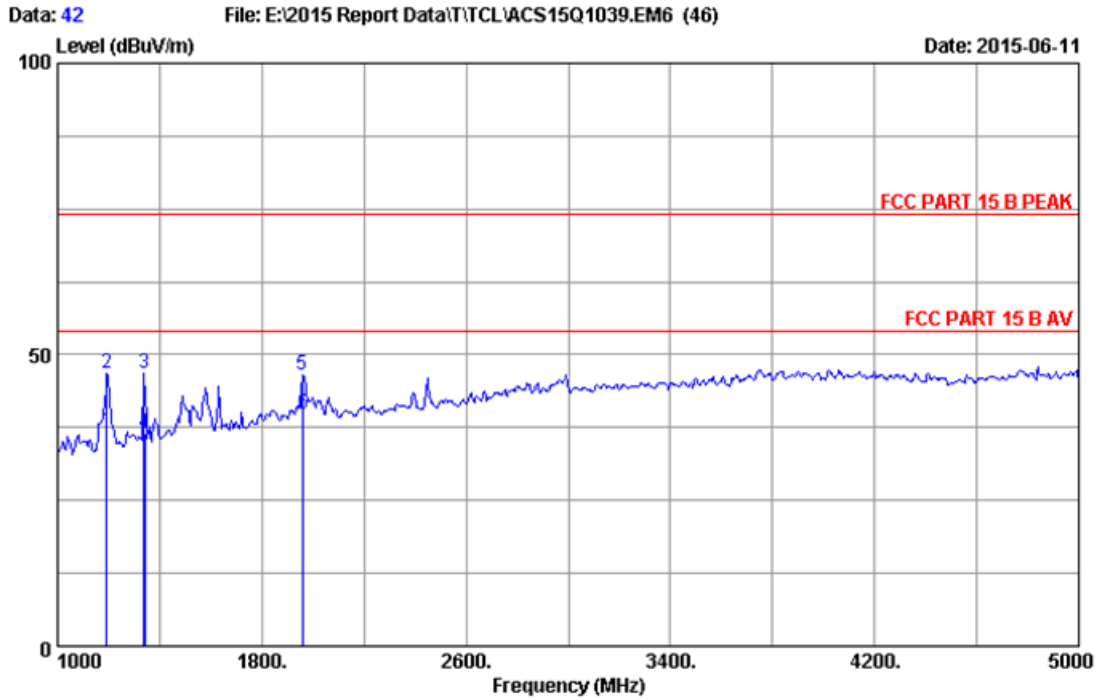

Site no. : 3m Chamber Data no. : 42
 Dis. / Ant. : 3m 2014 3115 9607-4877 Ant. pol. : VERTICAL
 Limit : FCC PART 15 B PEAK
 Env. / Ins. : 24°C/56% Engineer : Donjon
 EUT : LCD TV M/N:48FD2700
 Power rating : AC 120V/60Hz
 Test Mode : PC Mode
 : Running"H"Pattern And 1KHz Playing
 HDMI 1:1920*1080@60Hz

| No. | Freq. (MHz) | Ant. Factor (dB/m) | Cable Loss (dB) | Amp factor (dB) | Reading (dBuV) | Emission Level (dBuV/m) | Limits (dBuV/m) | Margin (dB) | Remark |
|-----|-------------|--------------------|-----------------|-----------------|----------------|-------------------------|-----------------|-------------|---------|
| 1 | 1191.56 | 24.58 | 1.94 | 36.72 | 46.87 | 36.67 | 54.00 | 17.33 | Average |
| 2 | 1192.00 | 24.58 | 1.94 | 36.72 | 56.92 | 46.72 | 74.00 | 27.28 | Peak |
| 3 | 1340.00 | 25.30 | 2.18 | 36.28 | 55.46 | 46.66 | 74.00 | 27.34 | Peak |
| 4 | 1341.59 | 25.31 | 2.18 | 36.28 | 45.36 | 36.57 | 54.00 | 17.43 | Average |
| 5 | 1960.00 | 27.49 | 2.71 | 34.07 | 50.49 | 46.62 | 74.00 | 27.38 | Peak |
| 6 | 1961.54 | 27.49 | 2.72 | 34.07 | 43.66 | 39.80 | 54.00 | 14.20 | Average |

Remarks: 1. Emission Level= Antenna Factor + Cable Loss + Reading - Amp factor.
 2. The emission levels that are 20dB below the official limit are not reported.

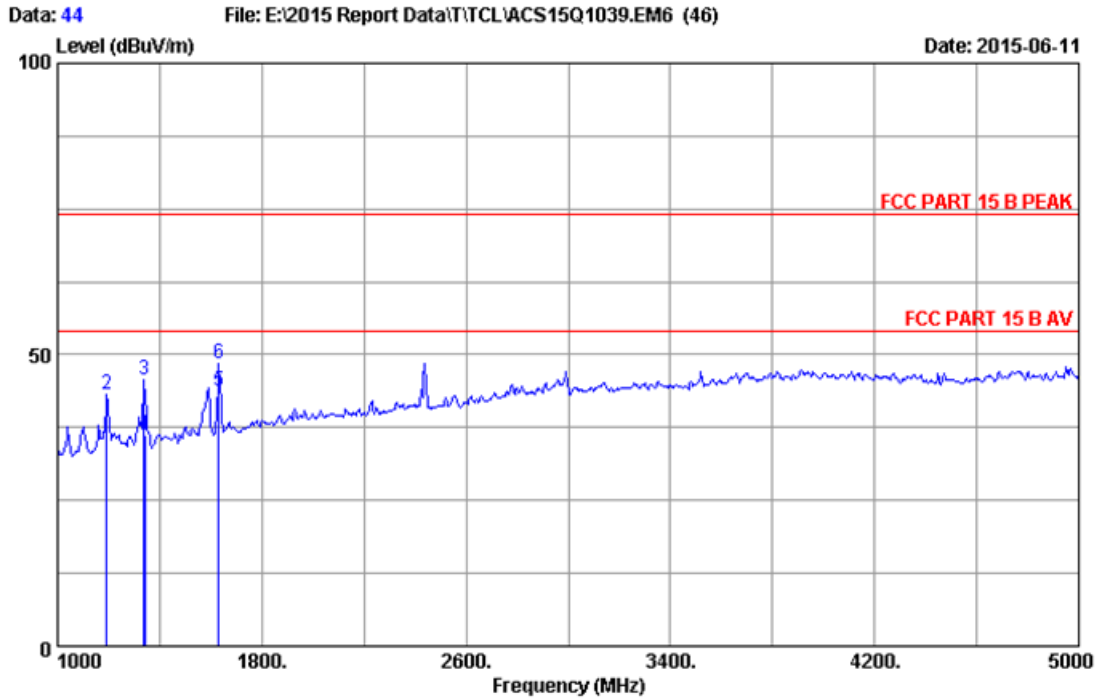

Site no. : 3m Chamber Data no. : 44
 Dis. / Ant. : 3m 2014 3115 9607-4877 Ant. pol. : HORIZONTAL
 Limit : FCC PART 15 B PEAK
 Env. / Ins. : 24°C/56% Engineer : Donjon
 EUT : LCD TV M/N:48FD2700
 Power rating : AC 120V/60Hz
 Test Mode : PC Mode
 : Running"H"Pattern And 1KHz Playing
 HDMI 2:1920*1080@60Hz

| No. | Freq. (MHz) | Ant. Factor (dB/m) | Cable Loss (dB) | Amp factor (dB) | Reading (dBuV) | Emission Level (dBuV/m) | Limits (dBuV/m) | Margin (dB) | Remark |
|-----|-------------|--------------------|-----------------|-----------------|----------------|-------------------------|-----------------|-------------|---------|
| 1 | 1191.52 | 24.58 | 1.94 | 36.72 | 43.89 | 33.69 | 54.00 | 20.31 | Average |
| 2 | 1192.00 | 24.58 | 1.94 | 36.72 | 53.30 | 43.10 | 74.00 | 30.90 | Peak |
| 3 | 1340.00 | 25.30 | 2.18 | 36.28 | 54.42 | 45.62 | 74.00 | 28.38 | Peak |
| 4 | 1341.50 | 25.31 | 2.18 | 36.28 | 44.87 | 36.08 | 54.00 | 17.92 | Average |
| 5 | 1631.58 | 26.47 | 2.51 | 35.22 | 49.87 | 43.63 | 54.00 | 10.37 | Average |
| 6 | 1632.00 | 26.47 | 2.51 | 35.22 | 54.76 | 48.52 | 74.00 | 25.48 | Peak |

Remarks: 1. Emission Level= Antenna Factor + Cable Loss + Reading - Amp factor.
 2. The emission levels that are 20dB below the official limit are not reported.

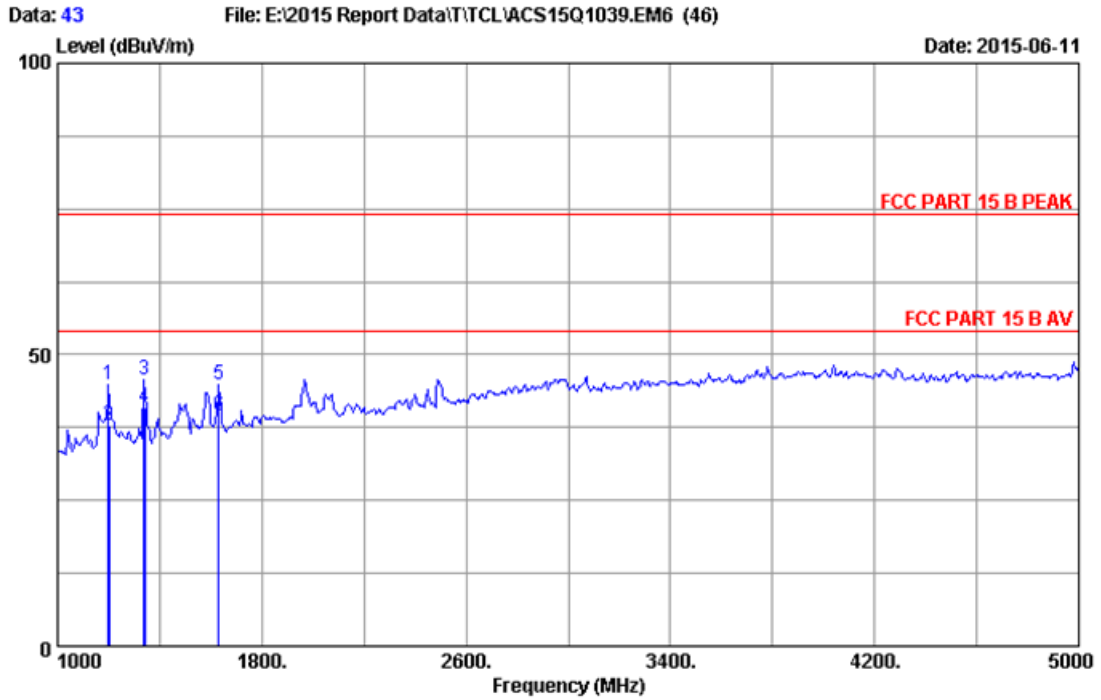

Site no. : 3m Chamber Data no. : 43
 Dis. / Ant. : 3m 2014 3115 9607-4877 Ant. pol. : VERTICAL
 Limit : FCC PART 15 B PEAK
 Env. / Ins. : 24°C/56% Engineer : Donjon
 EUT : LCD TV M/N:48FD2700
 Power rating : AC 120V/60Hz
 Test Mode : PC Mode
 : Running"H"Pattern And 1KHz Playing
 HDMI 2:1920*1080@60Hz

| No. | Freq. (MHz) | Ant. Factor (dB/m) | Cable Loss (dB) | Amp factor (dB) | Reading (dBuV) | Emission Level (dBuV/m) | Limits (dBuV/m) | Margin (dB) | Remark |
|-----|-------------|--------------------|-----------------|-----------------|----------------|-------------------------|-----------------|-------------|---------|
| 1 | 1200.00 | 24.62 | 1.97 | 36.72 | 54.92 | 44.79 | 74.00 | 29.21 | Peak |
| 2 | 1201.59 | 24.63 | 1.97 | 36.72 | 47.88 | 37.76 | 54.00 | 16.24 | Average |
| 3 | 1340.00 | 25.30 | 2.18 | 36.28 | 54.35 | 45.55 | 74.00 | 28.45 | Peak |
| 4 | 1341.58 | 25.31 | 2.18 | 36.28 | 49.87 | 41.08 | 54.00 | 12.92 | Average |
| 5 | 1632.00 | 26.47 | 2.51 | 35.22 | 51.00 | 44.76 | 74.00 | 29.24 | Peak |
| 6 | 1632.54 | 26.47 | 2.51 | 35.22 | 45.66 | 39.42 | 54.00 | 14.58 | Average |

Remarks: 1. Emission Level= Antenna Factor + Cable Loss + Reading - Amp factor.
 2. The emission levels that are 20dB below the official limit are not reported.

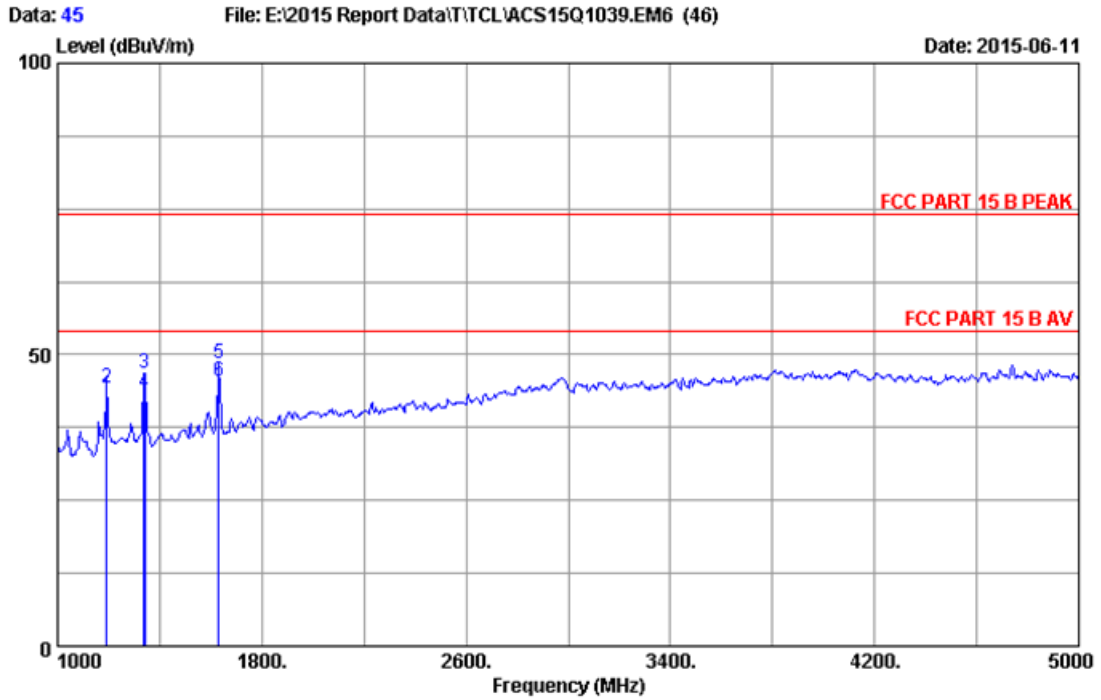

Site no. : 3m Chamber Data no. : 45
 Dis. / Ant. : 3m 2014 3115 9607-4877 Ant. pol. : HORIZONTAL
 Limit : FCC PART 15 B PEAK
 Env. / Ins. : 24°C/56% Engineer : Donjon
 EUT : LCD TV M/N:48FD2700
 Power rating : AC 120V/60Hz
 Test Mode : PC Mode
 : Running"H"Pattern And 1KHz Playing
 HDMI 3:1920*1080@60Hz

| No. | Freq. (MHz) | Ant. Factor (dB/m) | Cable Loss (dB) | Amp factor (dB) | Reading (dBuV) | Emission Level (dBuV/m) | Limits (dBuV/m) | Margin (dB) | Remark |
|-----|-------------|--------------------|-----------------|-----------------|----------------|-------------------------|-----------------|-------------|---------|
| 1 | 1191.58 | 24.58 | 1.94 | 36.72 | 53.21 | 43.01 | 54.00 | 10.99 | Average |
| 2 | 1192.00 | 24.58 | 1.94 | 36.72 | 54.43 | 44.23 | 74.00 | 29.77 | Peak |
| 3 | 1340.00 | 25.30 | 2.18 | 36.28 | 55.57 | 46.77 | 74.00 | 27.23 | Peak |
| 4 | 1341.50 | 25.31 | 2.18 | 36.28 | 52.33 | 43.54 | 54.00 | 10.46 | Average |
| 5 | 1632.00 | 26.47 | 2.51 | 35.22 | 54.77 | 48.53 | 74.00 | 25.47 | Peak |
| 6 | 1632.58 | 26.47 | 2.51 | 35.22 | 51.77 | 45.53 | 54.00 | 8.47 | Average |

Remarks: 1. Emission Level= Antenna Factor + Cable Loss + Reading - Amp factor.
 2. The emission levels that are 20dB below the official limit are not reported.

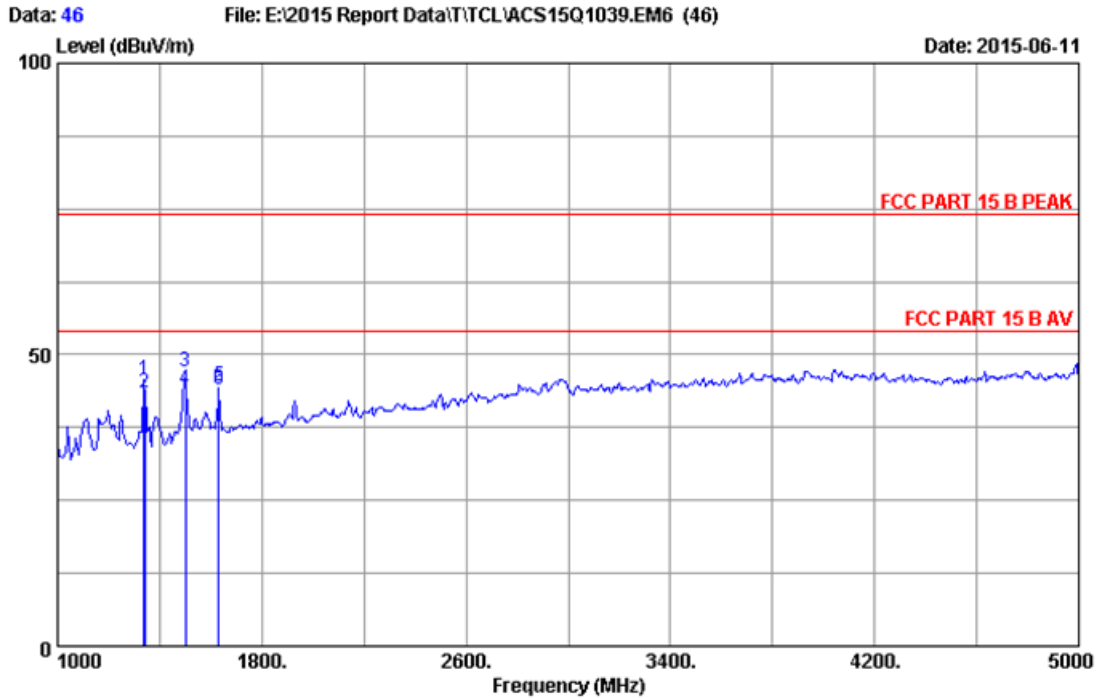

Site no. : 3m Chamber Data no. : 46
 Dis. / Ant. : 3m 2014 3115 9607-4877 Ant. pol. : VERTICAL
 Limit : FCC PART 15 B PEAK
 Env. / Ins. : 24°C/56% Engineer : Donjon
 EUT : LCD TV M/N:48FD2700
 Power rating : AC 120V/60Hz
 Test Mode : PC Mode
 : Running"H"Pattern And 1KHz Playing
 HDMI 3:1920*1080@60Hz

| No. | Freq. (MHz) | Ant. Factor (dB/m) | Cable Loss (dB) | Amp factor (dB) | Reading (dBuV) | Emission Level (dBuV/m) | Limits (dBuV/m) | Margin (dB) | Remark |
|-----|-------------|--------------------|-----------------|-----------------|----------------|-------------------------|-----------------|-------------|---------|
| 1 | 1340.00 | 25.30 | 2.18 | 36.28 | 54.43 | 45.63 | 74.00 | 28.37 | Peak |
| 2 | 1341.50 | 25.31 | 2.18 | 36.28 | 52.33 | 43.54 | 54.00 | 10.46 | Average |
| 3 | 1500.00 | 26.00 | 2.42 | 35.66 | 54.31 | 47.07 | 74.00 | 26.93 | Peak |
| 4 | 1501.49 | 26.01 | 2.42 | 35.66 | 51.29 | 44.06 | 54.00 | 9.94 | Average |
| 5 | 1631.54 | 26.47 | 2.51 | 35.22 | 50.86 | 44.62 | 54.00 | 9.38 | Average |
| 6 | 1632.00 | 26.47 | 2.51 | 35.22 | 50.29 | 44.05 | 74.00 | 29.95 | Peak |

Remarks: 1. Emission Level= Antenna Factor + Cable Loss + Reading - Amp factor.
 2. The emission levels that are 20dB below the official limit are not reported.

5. DEVIATION TO TEST SPECIFICATIONS

[NONE]