

Application for FCC Certificate
On Behalf of

TTE Technology, Inc.

LCD TV or LED TV

Model Number: 43R50

FCC ID:W8U43R50

Prepared for : TTE Technology, Inc.
Address : 2455 Anselmo Drive Suite 101
Corona California United States

Prepared by : EST Technology Co., Ltd.
Address : San Tun Management Zone, Houjie Town, Dongguan,
Guangdong, China

Tel: 86-769-83081888
Fax: 86-769-83081878



Report No. : ESTE-R1705138
Date of Report : May 23,2017



TABLE OF CONTENTS

	Page
Test Report Declaration	
1. GENERAL PRODUCT INFORMATION	4
1.1. Product Function	4
1.2. Difference between Model Numbers	4
1.3. Independent Operation Modes	4
2. TEST SITES	5
2.1. Description of Standards and Results.....	5
2.2. Test Facilities	6
2.3. List of Test and Measurement Instruments	7
3. TEST SET-UP AND OPERATION MODES	8
3.1. Principle of Configuration Selection.....	8
3.2. Block Diagram of Test Set-up.....	8
3.3. Test Operation Mode and Test Software.....	9
3.4. Special Accessories and Auxiliary Equipment	9
3.5. Countermeasures to Achieve EMC Compliance.....	9
4. EMISSION TEST RESULTS	10
4.1. Conducted Emission at the Mains Terminals Test.....	10
4.2. Radiated Emission Test.....	13
5. PHOTOGRAPHS OF TEST SET-UP	19
5.1. Set-up for conducted emission at the mains terminals test.....	19
5.2. Set-up for radiated emission test (30-1000MHz)	20
5.3. Set-up for radiated emission test (Above 1GHz)	21
6. PHOTOGRAPHS OF THE EUT	22

EST Technology Co., Ltd.

Applicant:	TTE Technology, Inc.		
Address:	2455 Anselmo Drive Suite 101 Corona California United States		
Manufacturer	TCL King Electrical Appliances(Huizhou) Co.,Ltd		
Address:	Section 19,ZhongKai New and High-tech Industries Development Zone,Huizhou.Guangdong,P.R.China		
Factory 1:	TCL King Electrical Appliances(Huizhou) Co.,Ltd		
Address:	Section 19,ZhongKai New and High-tech Industries Development Zone,Huizhou.Guangdong,P.R.China		
Factory 2:	TCL Moka Manufacturing,S.A. de C.V.		
Address:	Calle 4TH No.55 CD industrial,TIJUANA BC 22444,MEXICO		
E.U.T:	LCD TV or LED TV		
Model Number:	43R50		
Additional Model:	M43R4、43RZ5、**43**** (* can be A-Z,0-9 or "-" or blank)		
Trade Name:	HITACHI	Serial No.:	-----
Date of Receipt:	May 11,2017	Date of Test:	May 11,2017~May 23,2017
Test Specification:	FCC Rules and Regulations Part 15 Subpart B:2016 ANSI C63.4:2014		
Test Result:	<p>The device described above is tested by EST Technology Co., Ltd. The measurement results were contained in this test report and EST Technology Co., Ltd. was assumed full responsibility for the accuracy and completeness of these measurements. Also, this report shows that the EUT to be technically compliance with the FCC Rules and Regulations Part 15 Subpart B requirements. This report applies to above tested sample only and shall not be reproduced in part without written approval of EST Technology Co., Ltd.</p> <p style="text-align: right;">Issue Date: May 23,2017</p>		
Prepared by:	Reviewed by:	Approved by:	
			
Amy / Assistant	Seven/ Engineer	Iceman Hu / Manager	
Other Aspects:	None.		
<i>Abbreviations: OK/P=passed fail/F=failed n.a/N=not applicable E.U.T=equipment under tested</i>			



1. GENERAL PRODUCT INFORMATION

1.1. Product Function

Refer to Technical Construction Form and User Manual.

1.2. Difference between Model Numbers

Note: The Product only different model number,
But the PCB board inside are identical.

1.3. Independent Operation Modes

1.3.1. Conducted Modes

1	HDMI(1920*1080+Running "H" Pattern)	Worst case
2	HDMI(1024*768+Running "H" Pattern)	
3	HDMI(800*600+Running "H" Pattern)	
Note: The worst case will be recorded in this report.		

1.3.2. Radiated Modes

30MHz~1GHz		
1	HDMI(1920*1080+Running "H" Pattern)	Worst case
2	HDMI(1024*768+Running "H" Pattern)	
3	HDMI(800*600+Running "H" Pattern)	
Above 1GHz		
1	HDMI(1920*1080+Running "H" Pattern)	Worst case
2	HDMI(1024*768+Running "H" Pattern)	
3	HDMI(800*600+Running "H" Pattern)	
Note: The worst case will be recorded in this report.		

2. TEST SITES

2.1. Description of Standards and Results

The EUT have been tested according to the applicable standards as referenced below

EMISSION			
Description of Test Item	Standard	Limits	Results
Conducted disturbance at mains terminals	FCC Rules and Regulations Part 15 Subpart B:2015 ANSI C63.4:2014	15.107(a) Class B	PASS
		Minimum passing margin is 6.91dB at 0.19MHz	
Radiated Emission Test	FCC Rules and Regulations Part 15 Subpart B:2015 ANSI C63.4:2014	15.109(a) Class B	PASS
		Minimum passing margin is 8.31dB at 742.95MHz for 30-1000MHz; Minimum passing margin is 7.03dB at 2375.00MHz for above 1GHZ;	

2.2. Test Facilities

EMC Lab	:	Certificated by CNAS, CHINA Registration No.: L5288 Date of registration: December 07, 2015 Certificated by FCC, USA Registration No.: 989591 Date of registration: November 15, 2016 Certificated by Industry Canada Registration No.: 9405A-1 Date of registration: December 30, 2015 Certificated by VCCI, Japan Registration No.: R-3663 & C-4103 Date of registration: July 25, 2014 Certificated by TUV Rheinland, Germany Registration No.: UA 50195514 0001 Date of registration: January 07, 2011 Certificated by TUV/PS, Shenzhen Registration No.: SCN1017 Date of registration: January 27, 2011 Certificated by Intertek ETL SEMKO Registration No.: 2011-RTL-L1-18 Date of registration: April 28, 2011 Certificated by Nemko, Hong Kong Registration No.: 175193 Date of registration: May 4, 2011
Name of Firm	:	EST Technology Co., Ltd.
Site Location	:	San Tun Management Zone, Houjie Town, Dongguan, Guangdong, China

2.3. List of Test and Measurement Instruments

2.3.1. For conducted emission at the mains terminals test (844 Room)

Equipment	Manufacturer	Model No.	Serial No.	Last Cal.	Next Cal.
EMI Test Receiver	Rohde& Schwarz	ESVS30	832354	June 25,16	1 Year
Artificial Mains Network	Rohde& Schwarz	ENV216	101260	June 25,16	1 Year
Pulse Limiter	Rohde& Schwarz	ESH3-Z2	101100	June 25,16	1 Year

2.3.2. For radiated emission test

Equipment	Manufacturer	Model No.	Serial No.	Last Cal.	Next Cal.
EMI Test Receiver	Rohde& Schwarz	ESVS10	100004	June 25,16	1 Year
Spectrum Analyzer	Agilent	E4411B	MY50140697	June 25,16	1 Year
Bilog Antenna	Teseq	CBL 6111D	25872	June 28,15	3 Year
Signal Amplifier	Agilent	310N	187037	June 25,16	1 Year
Horn Antenna	SCHWARZBECK	BBHA9120D	8128-290	June 28,15	3 Year
Signal Amplifier	SCHWARZBECK	BBV9718	9718-212	June 25,16	1 Year
Spectrum Analyzer	Agilent	E4408B	MY44211139	June 25,16	1 Year

3. TEST SET-UP AND OPERATION MODES

3.1. Principle of Configuration Selection

Emission: The equipment under test (EUT) was configured to measure its highest possible radiation level. The test modes were adapted accordingly in reference to the Operating Instructions.

3.2. Block Diagram of Test Set-up

System Diagram of Connections between EUT and Simulators

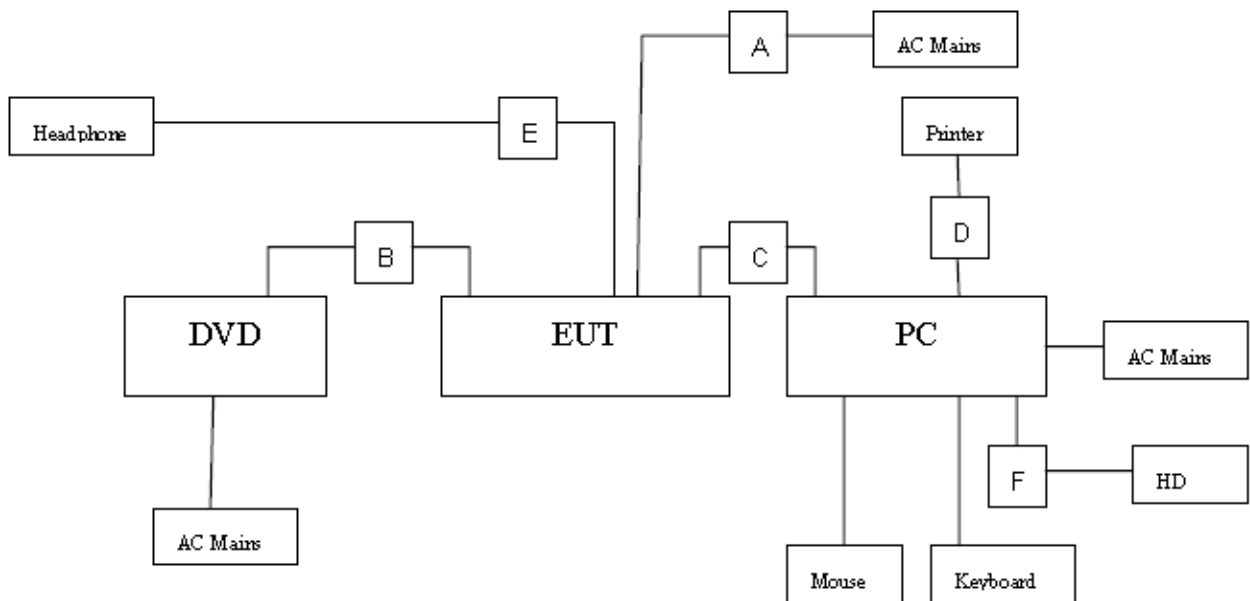

(EUT: LCD TV or LED TV)

A	AC Line	Unshielded, Undetachable 1.2m
B	AV IN	Unshielded, Detachable 1.2m
C	HDMI	Shielded, Detachable 1.2m
D	USB Cabel	Shielded, Detachable 1.8m
F	USB Cabel	Shielded, Detachable 1.0m

3.3. Test Operation Mode and Test Software

Refer to Test Setup in clause 4.

3.4. Special Accessories and Auxiliary Equipment

3.4.1. PC

M / N : VOSTRO
Manufacturer : DELL
Power Cord : Unshielded, Detachable, 1.6m

3.4.2. DVD Player

M / N : DVDHDMI01
Manufacturer : SAMWIN
Data Cable : Shielded, Undetachable, 1.6m

3.4.3. Printer

M / N : HP1020
Manufacturer : HP
Data Cable : Non-shielded, Detachable, 1.5m

3.4.4. Mouse

M / N : MOL5VO
S / N : JOQ03RNT
Manufacturer : Dell
cable : Shielded, Undetachable, 1.5m

3.4.5. Keyboard

M / N : L100
S / N : CN-0RH656-65890-01M-070T
Manufacturer : Dell
cable : Shielded, Undetachable, 1.8m

3.4.6. HD

M / N : A1446
Manufacturer : Apple
cable : Shielded, Undetachable, 1.0m

3.5. Countermeasures to Achieve EMC Compliance

None.

4. EMISSION TEST RESULTS

4.1. Conducted Emission at the Mains Terminals Test

RESULT : **Pass**
Test Procedure : ANSI C63.4:2014
Frequency Range : 0.15 to 30MHz
Test Site : Shielded Room
Limits : FCC Part 15:2016 Class B

Test Setup

Date of Test : May 18,2017
M/N : 43R50
Input Voltage : AC 120V/60Hz
Operation Mode : HDMI

The frequency range from 150 kHz to 30 MHz was investigated.

The bandwidth of the test receiver was set at 9 kHz.

The test data of the worst case condition(s) was reported on the following page.

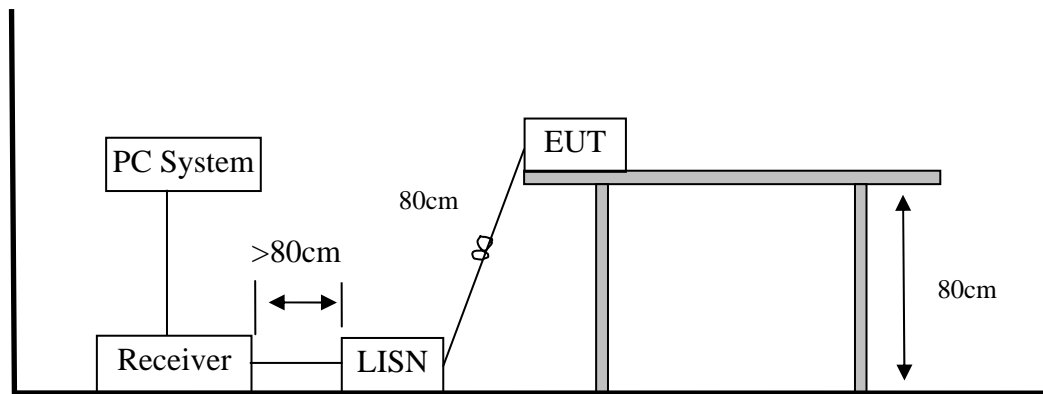

Note: Measurement Uncertainty: ± 2.54 dB at a level of confidence of 95%.

Test Data

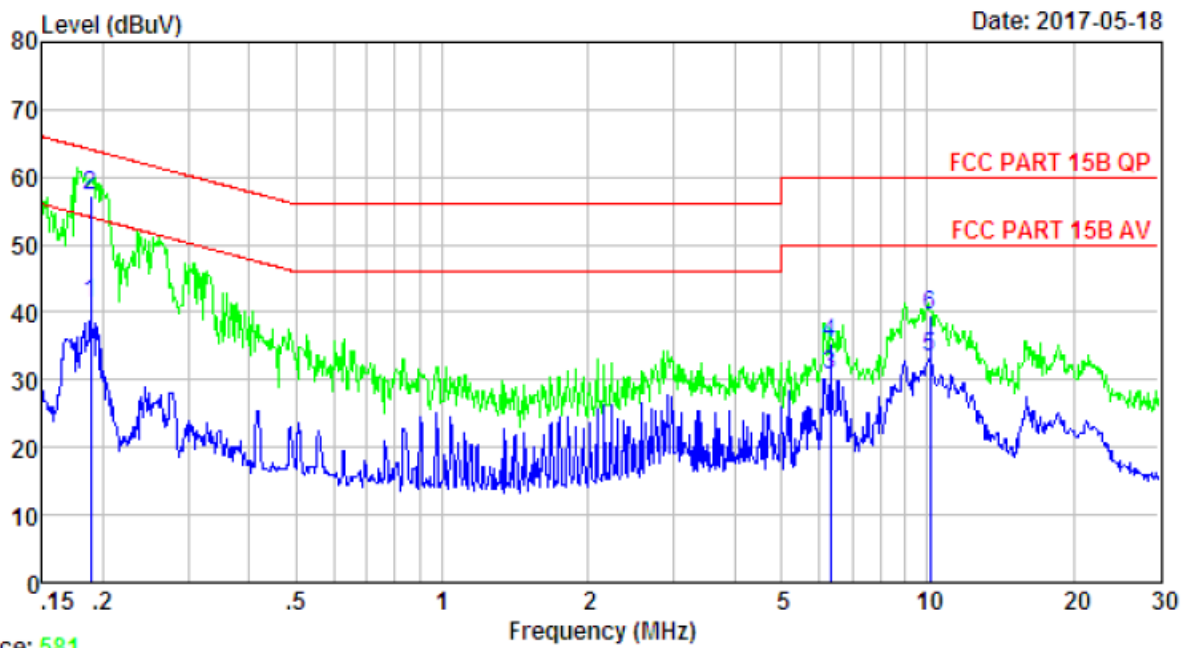

Trace: 581
 Site no : 844 Shield Room Data no. : 582
 Env. / Ins. : Temp:25.3'C Humi:58% Press:101.50kPa LINE Phase : LINE
 Limit : FCC PART 15B QP
 Engineer : Bible
 EUT : LCD TV or LED TV
 Power : AC 120V/60Hz
 M/N : 43R50
 Test Mode : HDMI (1920*1080+Running "H"Pattern)

	Freq. (MHz)	LISN Factor (dB)	Cable Loss (dB)	Reading (dBUV)	Emission Level (dBUV)	Limits (dBUV)	Margin (dB)	Remark
1	0.19	9.61	9.80	21.79	41.20	54.11	12.91	Average
2	0.19	9.61	9.80	37.79	57.20	64.11	6.91	QP
3	6.32	9.66	9.86	11.05	30.57	50.00	19.43	Average
4	6.32	9.66	9.86	16.05	35.57	60.00	24.43	QP
5	10.13	9.66	9.88	13.88	33.42	50.00	16.58	Average
6	10.13	9.66	9.88	19.88	39.42	60.00	20.58	QP

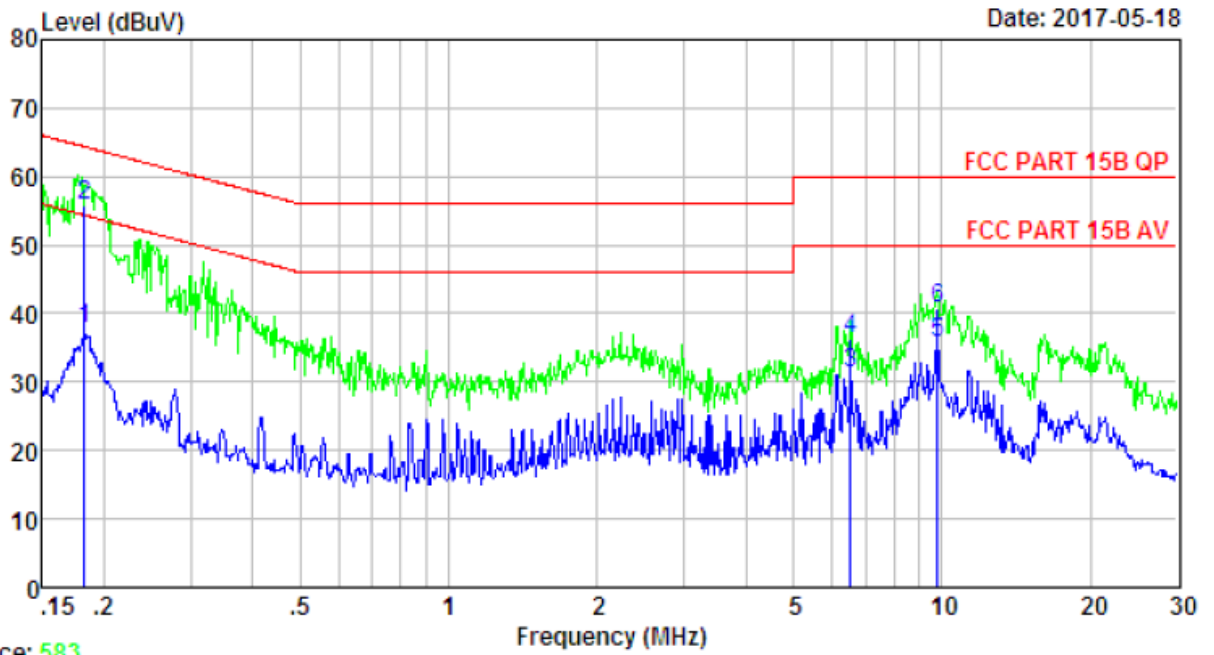

Trace: 583
 Site no : 844 Shield Room Data no. : 584
 Env. / Ins. : Temp:25.3°C Humi:58% Press:101.50kPa LINE Phase : NEUTRAL
 Limit : FCC PART 15B QP
 Engineer : Bible
 EUT : LCD TV or LED TV
 Power : AC 120V/60Hz
 M/N : 43R50
 Test Mode : HDMI (1920*1080+Running "H"Pattern)

	Freq. (MHz)	LISN Factor (dB)	Cable Loss (dB)	Reading (dBuV)	Emission Level (dBuV)	Limits (dBuV)	Margin (dB)	Remark
1	0.18	9.56	9.80	18.53	37.89	54.37	16.48	Average
2	0.18	9.56	9.80	36.53	55.89	64.37	8.48	QP
3	6.52	9.66	9.86	11.75	31.27	50.00	18.73	Average
4	6.52	9.66	9.86	16.75	36.27	60.00	23.73	QP
5	9.81	9.70	9.89	16.11	35.70	50.00	14.30	Average
6	9.81	9.70	9.89	21.11	40.70	60.00	19.30	QP

4.2. Radiated Emission Test

RESULT : **Pass**
Test Procedure : ANSI C63.4:2014
Frequency Range : 30-1000 MHz;1-6 GHz
Test Site : 966 Chamber
Limits : FCC Part 15:2016 Class B

Test Setup

Date of Test : May 15,2017~May 17,2017
M/N : 43R50
Input Voltage : AC 120V/60Hz
Operation Mode : HDMI

The EUT was placed on a turn table which was 0.8 m above the ground. The turn table can rotate 360 degrees to determine the position of the maximum emission level. The EUT was set 3 m away from the receiving antenna which was mounted on an antenna tower. The measuring antenna moved up and down to find out the maximum emission level. It moved from 1 m to 4 m for both horizontal and vertical polarizations.

The EUT was tested in the Chamber Site. It was pre-scanned with a Peak detector from the spectrum, and all the final readings from the test receiver were measured with the Quasi-Peak detector.

The bandwidth setting on the test receiver was 120 kHz.

The bandwidth of the Spectrum's VBW is set at 3MHz and RBW is set at 1MHz for peak emissions measurement above 1GHz and 1MHz RBW, 10Hz VBW for average emissions measure above 1GHz

The test data of the worst case condition(s) was reported on the following page.

1、 In Semi-anechoic Chamber Test Setup Diagram for 30MHz~1000MHz

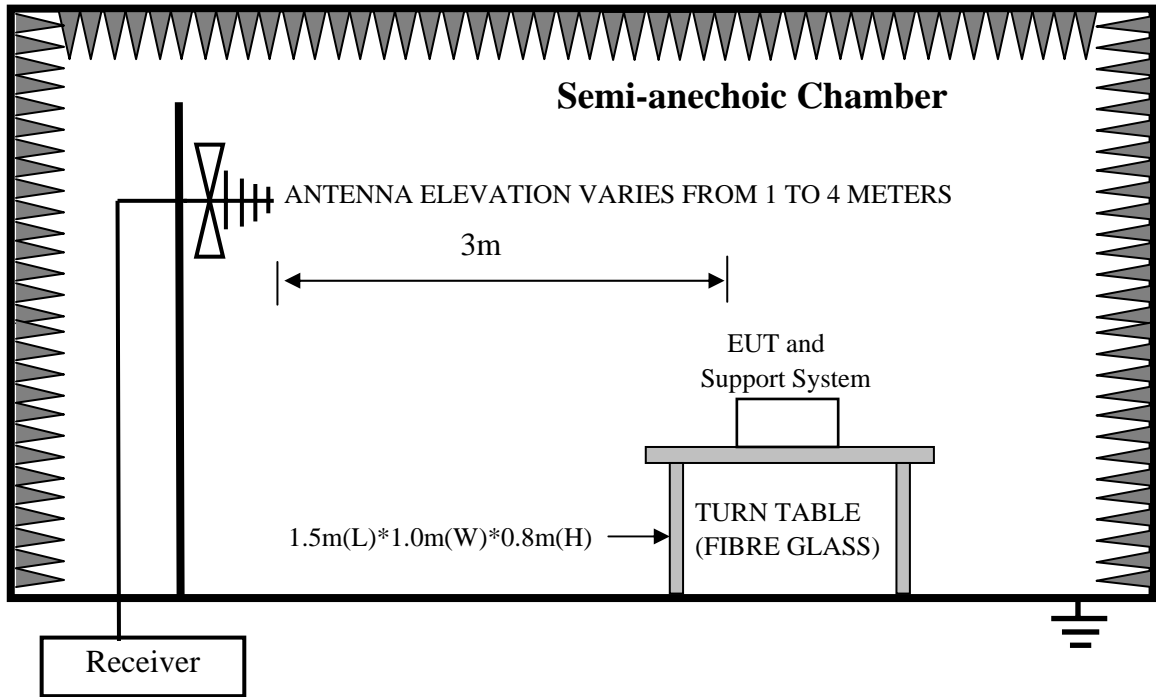

2、 In Anechoic Chamber Test Setup Diagram for 1-6GHz

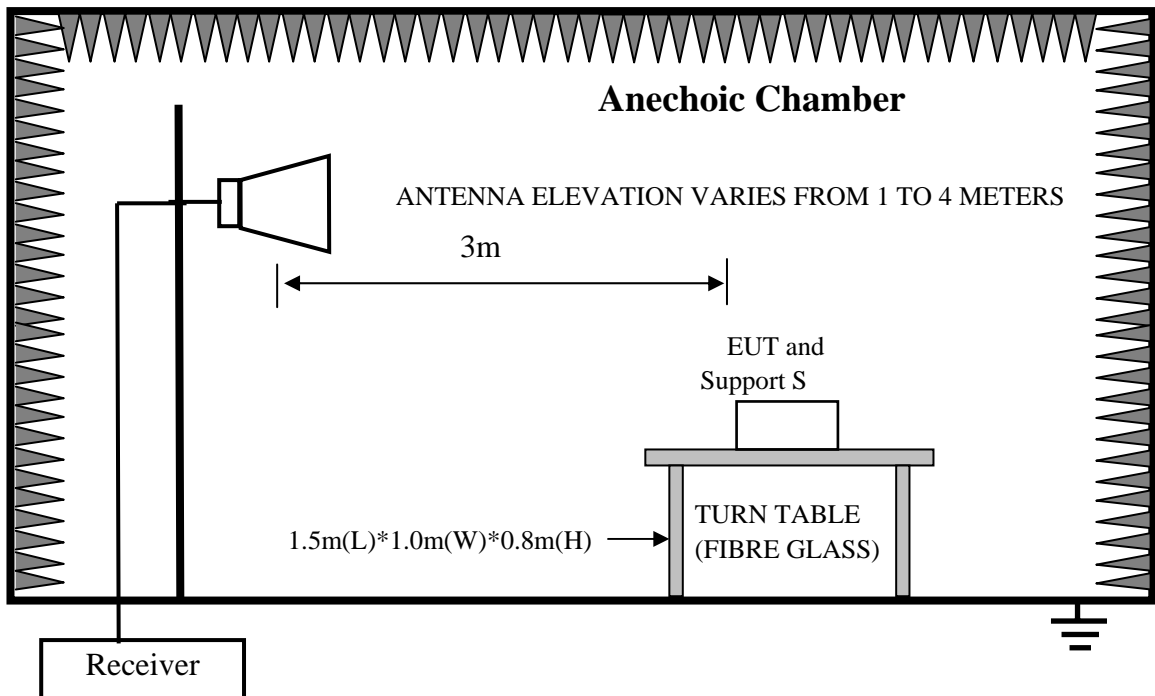

Test uncertainty: $\pm 3.62\text{dB}$ at a level of confidence of 95%.

Test Data

30MHz-1GHz

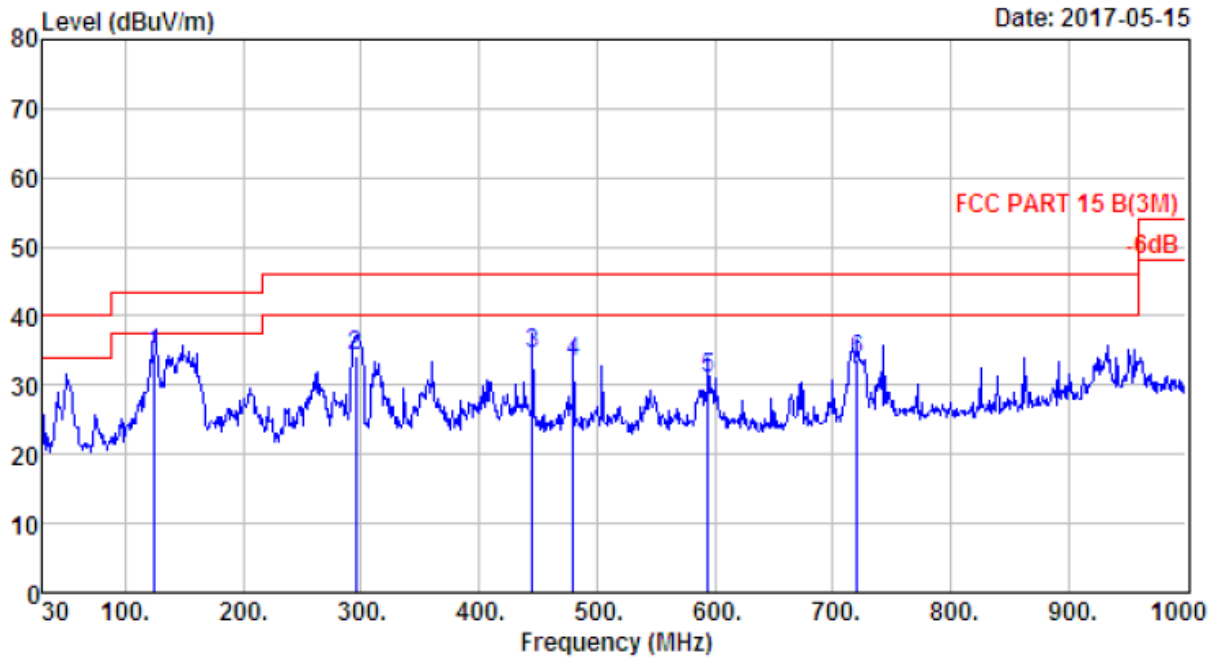

```

Site no.       : 1# 966 Chamber           Data no.   : 98
Dis. / Ant.    : 3m 27137                Ant. pol.  : VERTICAL
Limit          : FCC PART 15 B(3M)
Env. / Ins.    : Temp:23.6';Humi:56%;Press:101.52kPa
Engineer       : Bible
EUT            : LCD TV or LED TV
Power          : AC 120V/60Hz
M/N            : 43R50
Test Mode      : HDMI (1920*1080+Running "H"Pattern)
    
```

	Freq. (MHz)	ANT Factor (dB/m)	Cable Loss (dB)	Reading (dBuV)	Emission Level (dBuV/m)	Limit (dBuV/m)	Margin (dB)	Remark
1	125.060	11.35	1.52	21.73	34.60	43.50	8.90	QP
2	295.780	12.98	2.28	19.04	34.30	46.00	11.70	QP
3	445.160	16.36	2.92	15.20	34.48	46.00	11.52	QP
4	480.080	17.45	3.10	12.76	33.31	46.00	12.69	QP
5	594.540	19.51	3.33	8.08	30.92	46.00	15.08	QP
6	720.640	21.55	3.72	8.41	33.68	46.00	12.32	QP

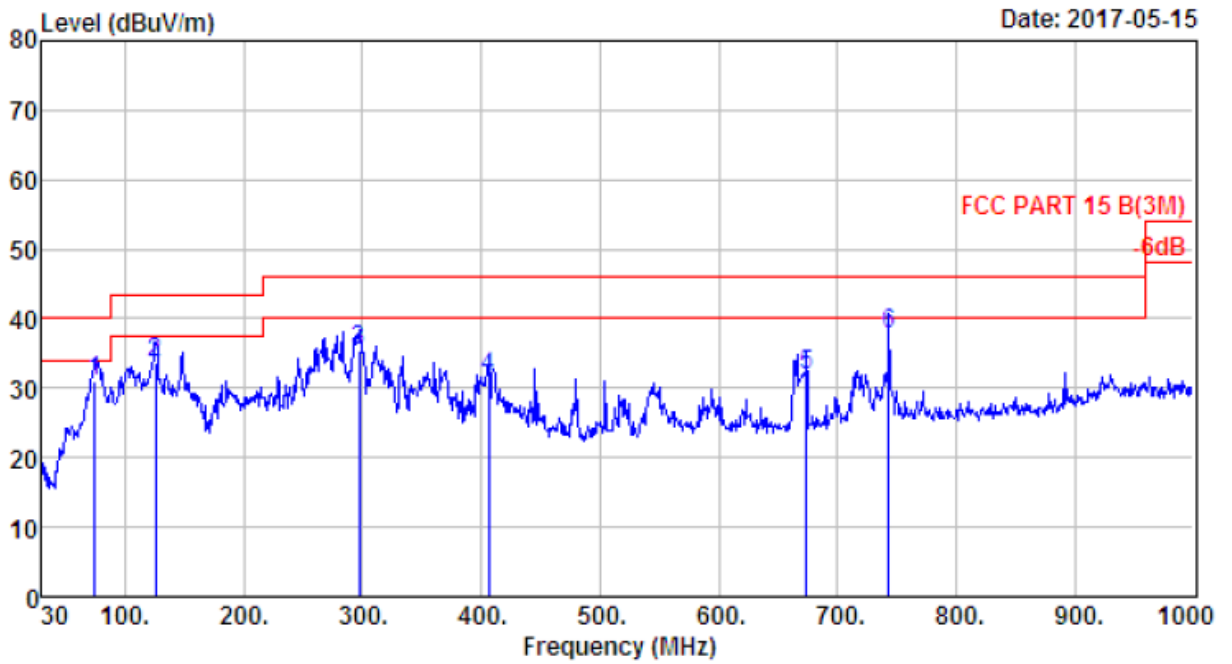

Site no. : 1# 966 Chamber Data no. : 99
 Dis. / Ant. : 3m 27137 Ant. pol. : HORIZONTAL
 Limit : FCC PART 15 B(3M)
 Env. / Ins. : Temp:23.6';Humi:56%;Press:101.52kPa
 Engineer : Bible
 EUT : LCD TV or LED TV
 Power : AC 120V/60Hz
 M/N : 43R50
 Test Mode : HDMI (1920*1080+Running "H"Pattern)

	Freq. (MHz)	ANT Factor (dB/m)	Cable Loss (dB)	Reading (dBuV)	Emission Level (dBuV/m)	Limit (dBuV/m)	Margin (dB)	Remark
1	74.620	6.36	1.17	23.47	31.00	40.00	9.00	QP
2	126.030	11.34	1.52	20.81	33.67	43.50	9.83	QP
3	296.750	12.99	2.32	20.02	35.33	46.00	10.67	QP
4	406.360	16.20	2.64	12.89	31.73	46.00	14.27	QP
5	674.080	20.25	3.64	8.11	32.00	46.00	14.00	QP
6	742.950	22.31	3.86	11.52	37.69	46.00	8.31	QP

Above 1GHz

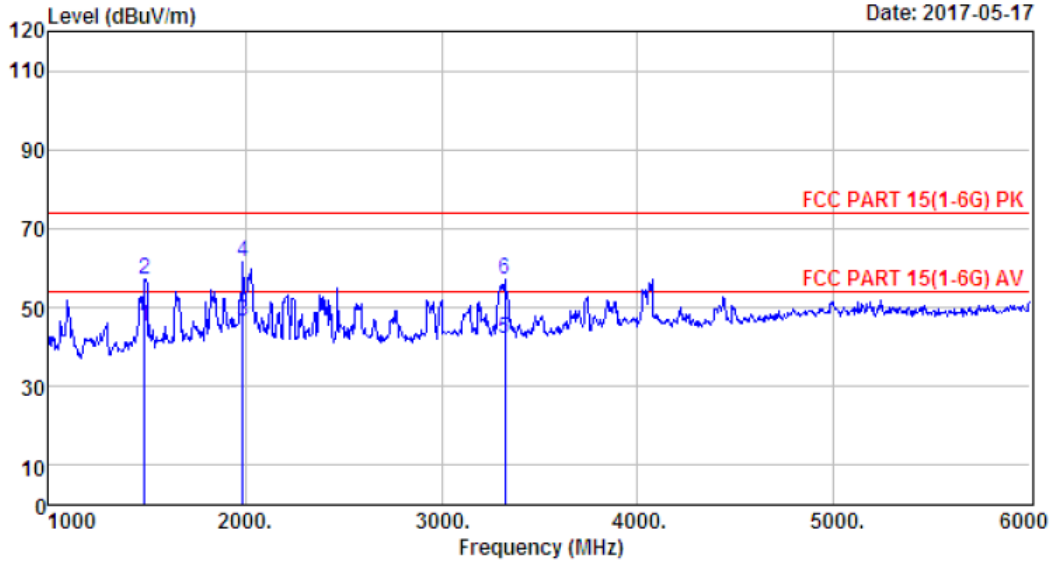

Site no. : 1# 966 Chamber Data no. : 92
 Dis. / Ant. : 3m ANT 1-18G Ant. pol. : VERTICAL
 Limit : FCC PART 15(1-6G) PK
 Env. / Ins. : Temp:23.6';Humi:56%;Press:101.52kPa
 Engineer : Bible
 EUT : LCD TV or LED TV
 Power : AC 120V/60Hz
 M/N : 43R50
 Test Mode : HDMI (1920*1080+Running "H"Pattern)

	Freq. (MHz)	Ant. Factor (dB/m)	Cable Loss (dB)	Amp Factor (dB)	Reading (dBuV)	Emission Level (dBuV/m)	Limits (dBuV/m)	Margin (dB)	Remark
1	1490.00	24.93	4.32	35.17	51.26	45.34	54.00	8.66	Average
2	1490.00	24.93	4.32	35.17	63.26	57.34	74.00	16.66	Peak
3	1990.00	25.79	6.13	35.08	49.68	46.52	54.00	7.48	Average
4	1990.00	25.79	6.13	35.08	64.68	61.52	74.00	12.48	Peak
5	3325.00	27.83	8.81	36.08	41.36	41.92	54.00	12.08	Average
6	3325.00	27.83	8.81	36.08	56.36	56.92	74.00	17.08	Peak

Remarks: 1. Emission Level= Antenna Factor + Cable Loss - Amp Factor + Reading.
 2. The emission levels that are 20dB below the official limit are not reported.



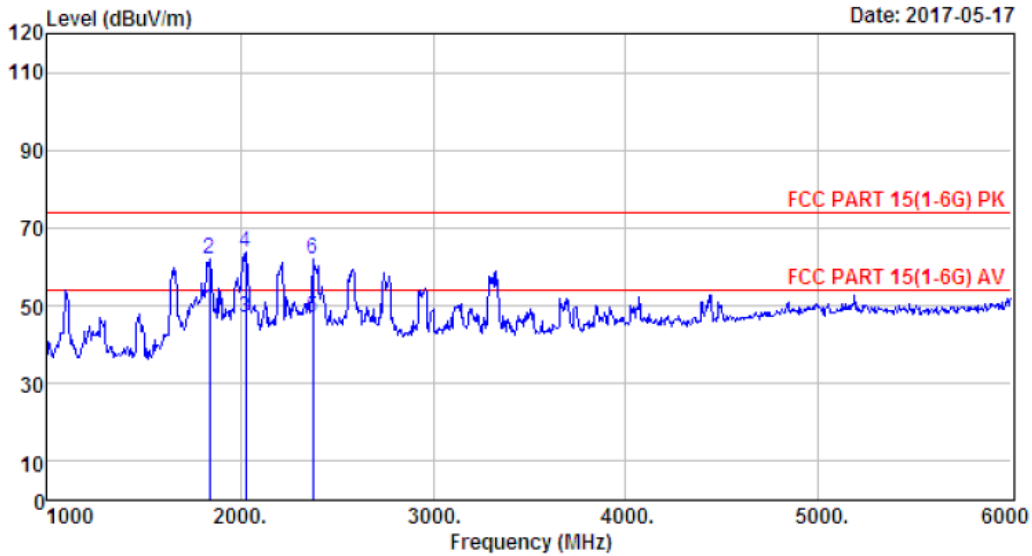

Site no. : 1# 966 Chamber Data no. : 93
 Dis. / Ant. : 3m ANT 1-18G Ant. pol. : HORIZONTAL
 Limit : FCC PART 15(1-6G) PK
 Env. / Ins. : Temp:23.6';Humi:56%;Press:101.52kPa
 Engineer : Bible
 EUT : LCD TV or LED TV
 Power : AC 120V/60Hz
 M/N : 43R50
 Test Mode : HDMI (1920*1080+Running "H"Pattern)

	Freq. (MHz)	Ant. Factor (dB/m)	Cable Loss (dB)	Amp Factor (dB)	Reading (dBUV)	Emission Level (dBUV/m)	Limits (dBUV/m)	Margin (dB)	Remark
1	1840.00	25.09	5.57	35.27	53.73	49.12	54.00	4.88	Average
2	1840.00	25.09	5.57	35.27	66.73	62.12	74.00	11.88	Peak
3	2030.00	26.30	6.23	35.05	49.29	46.77	54.00	7.23	Average
4	2030.00	26.30	6.23	35.05	66.29	63.77	74.00	10.23	Peak
5	2375.00	27.64	6.60	34.59	47.32	46.97	54.00	7.03	Average
6	2375.00	27.64	6.60	34.59	62.32	61.97	74.00	12.03	Peak

Remarks: 1. Emission Level= Antenna Factor + Cable Loss - Amp Factor + Reading.
 2. The emission levels that are 20dB below the official limit are not reported.



5. PHOTOGRAPHS OF TEST SET-UP

5.1. Set-up for conducted emission at the mains terminals test



5.2. Set-up for radiated emission test (30-1000MHz)



5.3. Set-up for radiated emission test (Above 1GHz)



6. PHOTOGRAPHS OF THE EUT

External Photos
M/N: 43R50



External Photos
M/N: 43R50



External Photos
M/N: 43R50



External Photos
M/N: 43R50



Internal Photos
M/N: 43R50

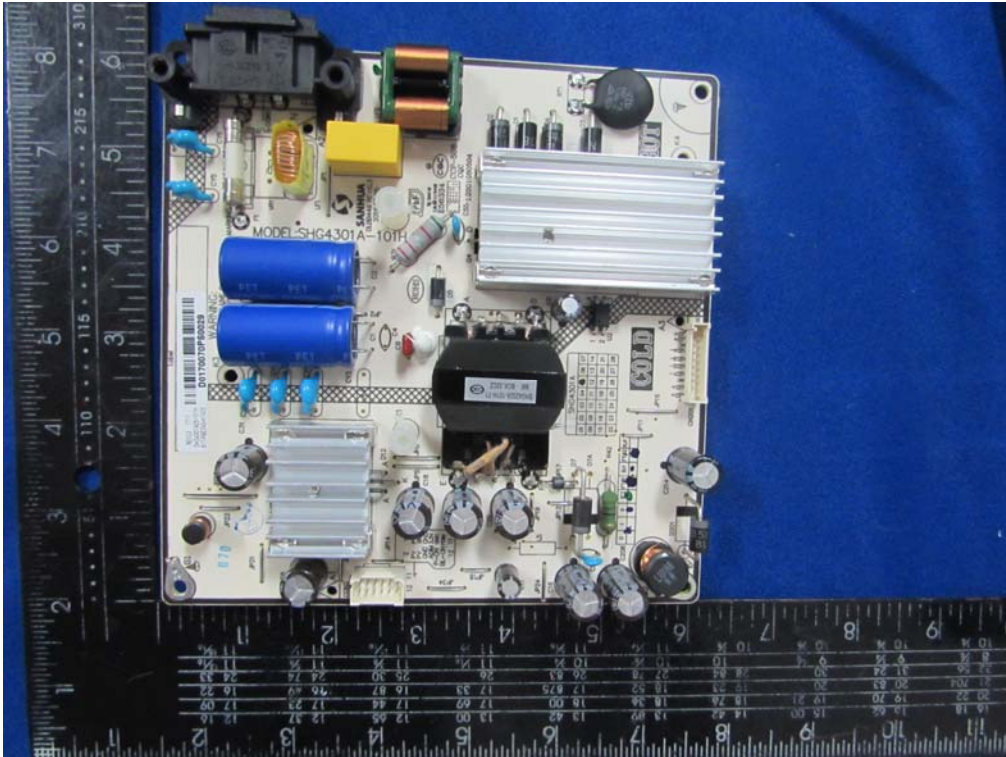

Internal Photos
M/N: 43R50

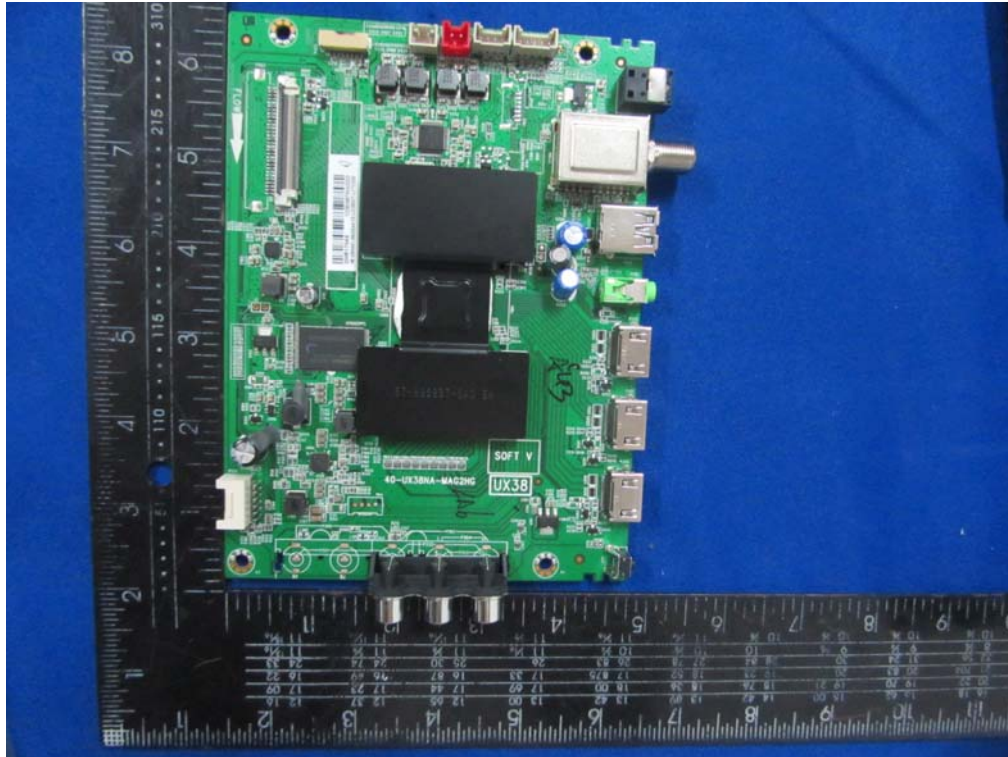
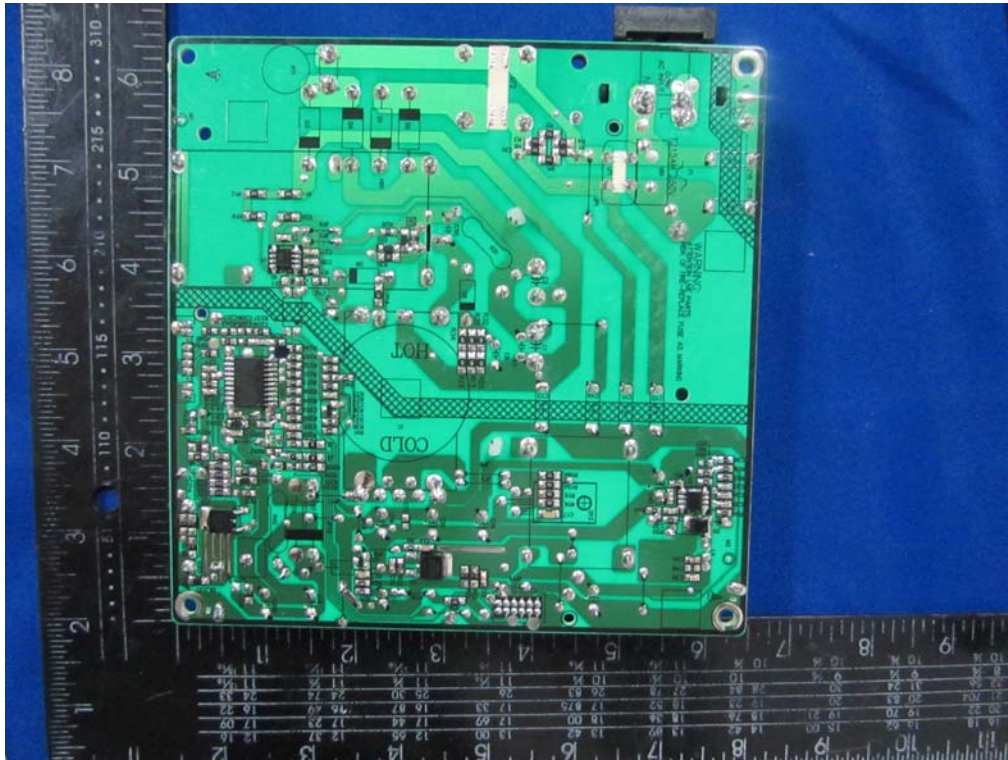

Internal Photos
M/N: 43R50

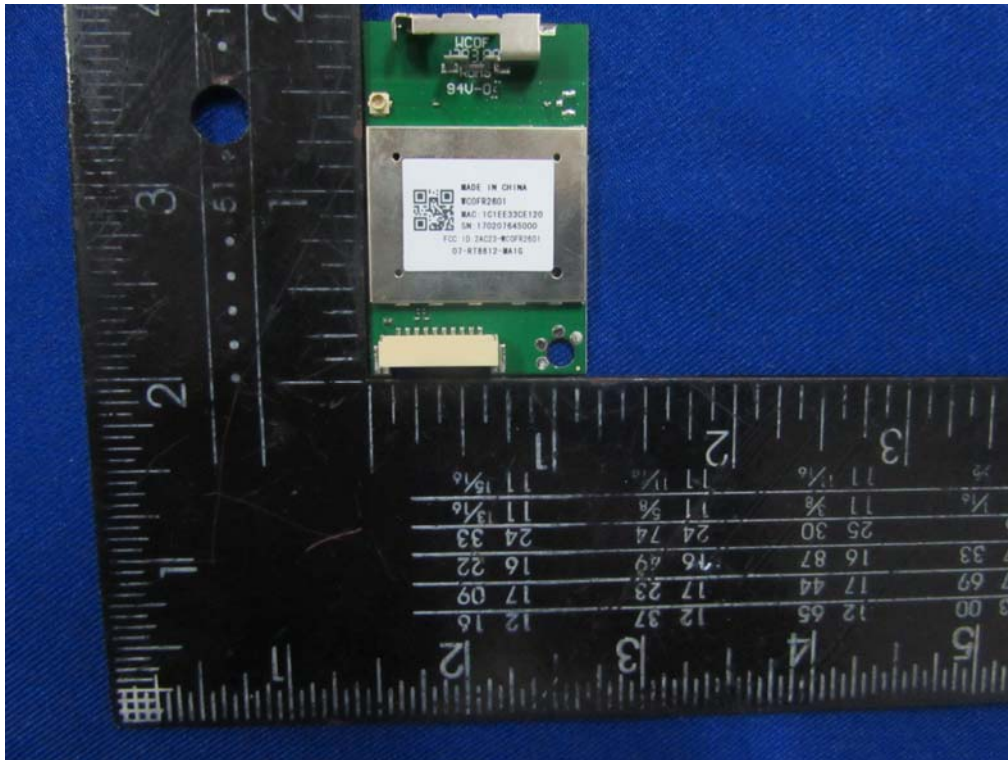

Internal Photos
M/N: 43R50

