

Application for FCC Certificate  
On Behalf of

TTE Technology, Inc.

LCD TV or LED TV

Model Number: 32R20

FCC ID:W8U32R20

Prepared for : TTE Technology, Inc.  
Address : 2455 Anselmo Drive Suite 101  
Corona California United States

Prepared by : EST Technology Co., Ltd.  
Address : San Tun Management Zone, Houjie Town, Dongguan,  
Guangdong, China



Tel: 86-769-83081888  
Fax: 86-769-83081878

Report No. : ESTE-R1705136  
Date of Report : May 23,2017

## TABLE OF CONTENTS

	Page
Test Report Declaration	
<b>1. GENERAL PRODUCT INFORMATION</b> .....	<b>4</b>
1.1. Product Function .....	4
1.2. Difference between Model Numbers .....	4
1.3. Independent Operation Modes .....	4
<b>2. TEST SITES</b> .....	<b>5</b>
2.1. Description of Standards and Results.....	5
2.2. Test Facilities .....	6
2.3. List of Test and Measurement Instruments .....	7
<b>3. TEST SET-UP AND OPERATION MODES</b> .....	<b>8</b>
3.1. Principle of Configuration Selection.....	8
3.2. Block Diagram of Test Set-up.....	8
3.3. Test Operation Mode and Test Software.....	9
3.4. Special Accessories and Auxiliary Equipment .....	9
3.5. Countermeasures to Achieve EMC Compliance.....	9
<b>4. EMISSION TEST RESULTS</b> .....	<b>10</b>
4.1. Conducted Emission at the Mains Terminals Test.....	10
4.2. Radiated Emission Test.....	13
<b>5. PHOTOGRAPHS OF TEST SET-UP</b> .....	<b>19</b>
5.1. Set-up for conducted emission at the mains terminals test.....	19
5.2. Set-up for radiated emission test (30-1000MHz) .....	20
5.3. Set-up for radiated emission test (Above 1GHz) .....	21
<b>6. PHOTOGRAPHS OF THE EUT</b> .....	<b>22</b>

## EST Technology Co., Ltd.

<b>Applicant:</b>	TTE Technology, Inc.		
<b>Address:</b>	2455 Anselmo Drive Suite 101 Corona California United States		
<b>Manufacturer</b>	TCL King Electrical Appliances(Huizhou) Co.,Ltd		
<b>Address:</b>	Section 19,ZhongKai New and High-tech Industries Development Zone,Huizhou.Guangdong,P.R.China		
<b>Factory 1:</b>	TCL King Electrical Appliances(Huizhou) Co.,Ltd		
<b>Address:</b>	Section 19,ZhongKai New and High-tech Industries Development Zone,Huizhou.Guangdong,P.R.China		
<b>Factory 2:</b>	TCL Moka Manufacturing,S.A. de C.V.		
<b>Address:</b>	Calle 4TH No.55 CD industrial,TIJUANA BC 22444,MEXICO		
<b>E.U.T:</b>	LCD TV or LED TV		
<b>Model Number:</b>	32R20		
<b>Additional Model:</b>	M32R1、32RZ2、**32**** (* can be A-Z,0-9 or “-” or blank)		
<b>Trade Name:</b>	HITACHI	<b>Serial No.:</b>	-----
<b>Date of Receipt:</b>	May 11,2017	<b>Date of Test:</b>	May 11,2017~May 23,2017
<b>Test Specification:</b>	FCC Rules and Regulations Part 15 Subpart B:2016 ANSI C63.4:2014		
<b>Test Result:</b>	<p>The device described above is tested by EST Technology Co., Ltd. The measurement results were contained in this test report and EST Technology Co., Ltd. was assumed full responsibility for the accuracy and completeness of these measurements. Also, this report shows that the EUT to be technically compliance with the FCC Rules and Regulations Part 15 Subpart B requirements. This report applies to above tested sample only and shall not be reproduced in part without written approval of EST Technology Co., Ltd.</p> <p style="text-align: right;"><b>Issue Date:</b> May 23,2017</p>		
<b>Prepared by:</b>	<b>Reviewed by:</b>	<b>Approved by:</b>	
			
Amy / Assistant	Seven Wang / Engineer	Iceman Hu / Manager	
<b>Other Aspects:</b>	None.		
<i>Abbreviations: OK/P=passed    fail/F=failed    n.a/N=not applicable    E.U.T=equipment under tested</i>			

# 1. GENERAL PRODUCT INFORMATION

## 1.1. Product Function

Refer to Technical Construction Form and User Manual.

## 1.2. Difference between Model Numbers

**Note:** The Product only different model number,  
But the PCB board inside are identical.

## 1.3. Independent Operation Modes

### 1.3.1. Conducted Modes

1	HDMI(1920*1080+Running "H" Pattern)	Worst case
2	HDMI(1024*768+Running "H" Pattern)	
3	HDMI(800*600+Running "H" Pattern)	
Note: The worst case will be recorded in this report.		

### 1.3.2. Radiated Modes

30MHz~1GHz		
1	HDMI(1920*1080+Running "H" Pattern)	Worst case
2	HDMI(1024*768+Running "H" Pattern)	
3	HDMI(800*600+Running "H" Pattern)	
Above 1GHz		
1	HDMI(1920*1080+Running "H" Pattern)	Worst case
2	HDMI(1024*768+Running "H" Pattern)	
3	HDMI(800*600+Running "H" Pattern)	
Note: The worst case will be recorded in this report.		

## 2. TEST SITES

### 2.1. Description of Standards and Results

The EUT have been tested according to the applicable standards as referenced below

EMISSION			
Description of Test Item	Standard	Limits	Results
Conducted disturbance at mains terminals	FCC Rules and Regulations Part 15 Subpart B:2015 ANSI C63.4:2014	15.107(a) Class B	PASS
		Minimum passing margin is 10.16dB at 1.02MHz	
Radiated Emission Test	FCC Rules and Regulations Part 15 Subpart B:2015 ANSI C63.4:2014	15.109(a) Class B	PASS
		Minimum passing margin is 5.86dB at 742.95MHz for 30-1000MHz; Minimum passing margin is 4.65dB at 1885.00MHz for above 1GHZ;	

## 2.2. Test Facilities

EMC Lab : Certificated by CNAS, CHINA  
Registration No.: L5288  
Date of registration: December 07, 2015

Certificated by FCC, USA  
Registration No.: 989591  
Date of registration: November 15, 2016

Certificated by Industry Canada  
Registration No.: 9405A-1  
Date of registration: December 30, 2015

Certificated by VCCI, Japan  
Registration No.: R-3663 & C-4103  
Date of registration: July 25, 2014

Certificated by TUV Rheinland, Germany  
Registration No.: UA 50195514 0001  
Date of registration: January 07, 2011

Certificated by TUV/PS, Shenzhen  
Registration No.: SCN1017  
Date of registration: January 27, 2011

Certificated by Intertek ETL SEMKO  
Registration No.: 2011-RTL-L1-18  
Date of registration: April 28, 2011

Certificated by Nemko, Hong Kong  
Registration No.: 175193  
Date of registration: May 4, 2011

Name of Firm : EST Technology Co., Ltd.

Site Location : San Tun Management Zone, Houjie Town, Dongguan,  
Guangdong, China

### 2.3. List of Test and Measurement Instruments

#### 2.3.1. For conducted emission at the mains terminals test (844 Room)

Equipment	Manufacturer	Model No.	Serial No.	Last Cal.	Next Cal.
EMI Test Receiver	Rohde& Schwarz	ESVS30	832354	June 25,16	1 Year
Artificial Mains Network	Rohde& Schwarz	ENV216	101260	June 25,16	1 Year
Pulse Limiter	Rohde& Schwarz	ESH3-Z2	101100	June 25,16	1 Year

#### 2.3.2. For radiated emission test

Equipment	Manufacturer	Model No.	Serial No.	Last Cal.	Next Cal.
EMI Test Receiver	Rohde& Schwarz	ESVS10	100004	June 25,16	1 Year
Spectrum Analyzer	Agilent	E4411B	MY50140697	June 25,16	1 Year
Bilog Antenna	Teseq	CBL 6111D	25872	June 28,15	3 Year
Signal Amplifier	Agilent	310N	187037	June 25,16	1 Year
Horn Antenna	SCHWARZBECK	BBHA9120D	8128-290	June 28,15	3 Year
Signal Amplifier	SCHWARZBECK	BBV9718	9718-212	June 25,16	1 Year
Spectrum Analyzer	Agilent	E4408B	MY44211139	June 25,16	1 Year

### 3. TEST SET-UP AND OPERATION MODES

#### 3.1. Principle of Configuration Selection

**Emission:** The equipment under test (EUT) was configured to measure its highest possible radiation level. The test modes were adapted accordingly in reference to the Operating Instructions.

#### 3.2. Block Diagram of Test Set-up

System Diagram of Connections between EUT and Simulators

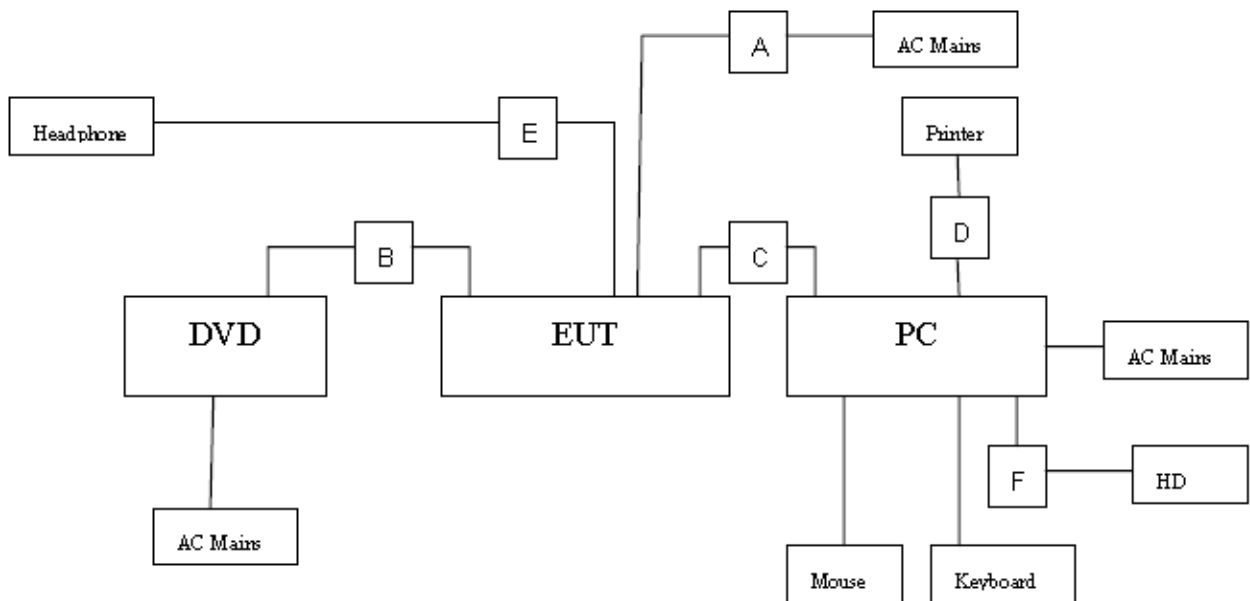

(EUT: LCD TV or LED TV)

A	AC Line	Unshielded, Undetachable 1.2m
B	AV IN	Unshielded, Detachable 1.2m
C	HDMI	Shielded, Detachable 1.2m
D	USB Cabel	Shielded, Detachable 1.8m
F	USB Cabel	Shielded, Detachable 1.0m



### 3.3. Test Operation Mode and Test Software

Refer to Test Setup in clause 4.

### 3.4. Special Accessories and Auxiliary Equipment

#### 3.4.1. PC

M / N : VOSTRO  
Manufacturer : DELL  
Power Cord : Unshielded, Detachable, 1.6m

#### 3.4.2. DVD Player

M / N : DVDHDMI01  
Manufacturer : SAMWIN  
Data Cable : Shielded, Undetachable, 1.6m

#### 3.4.3. Printer

M / N : HP1020  
Manufacturer : HP  
Data Cable : Non-shielded, Detachable, 1.5m

#### 3.4.4. Mouse

M / N : MOL5VO  
S / N : JOQ03RNT  
Manufacturer : Dell  
cable : Shielded, Undetachable, 1.5m

#### 3.4.5. Keyboard

M / N : L100  
S / N : CN-0RH656-65890-01M-070T  
Manufacturer : Dell  
cable : Shielded, Undetachable, 1.8m

#### 3.4.6. HD

M / N : A1446  
Manufacturer : Apple  
cable : Shielded, Undetachable, 1.0m

### 3.5. Countermeasures to Achieve EMC Compliance

None.

## 4. EMISSION TEST RESULTS

### 4.1. Conducted Emission at the Mains Terminals Test

**RESULT** : **Pass**  
Test Procedure : ANSI C63.4:2014  
Frequency Range : 0.15 to 30MHz  
Test Site : Shielded Room  
Limits : FCC Part 15:2016 Class B

#### Test Setup

Date of Test : May 17,2017  
M/N : 32R20  
Input Voltage : AC 120V/60Hz  
Operation Mode : HDMI

The frequency range from 150 kHz to 30 MHz was investigated.

The bandwidth of the test receiver was set at 9 kHz.

The test data of the worst case condition(s) was reported on the following page.

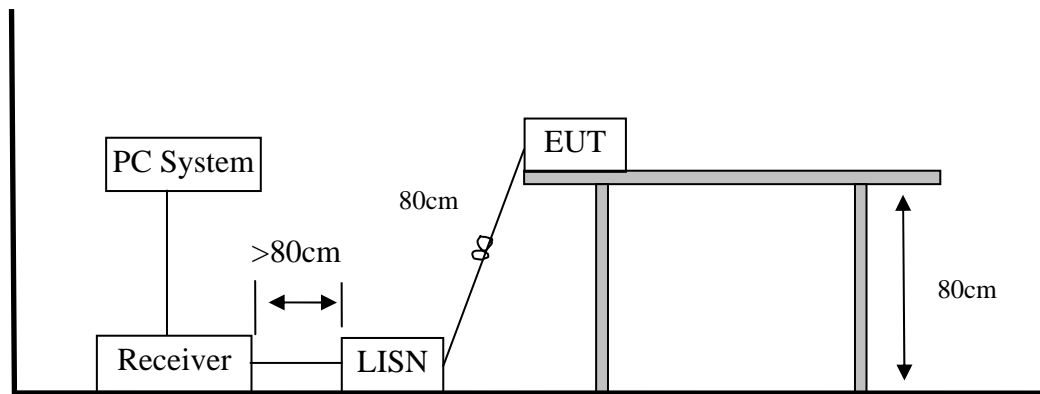

**Note: Measurement Uncertainty:  $\pm 2.54$  dB at a level of confidence of 95%.**

Test Data

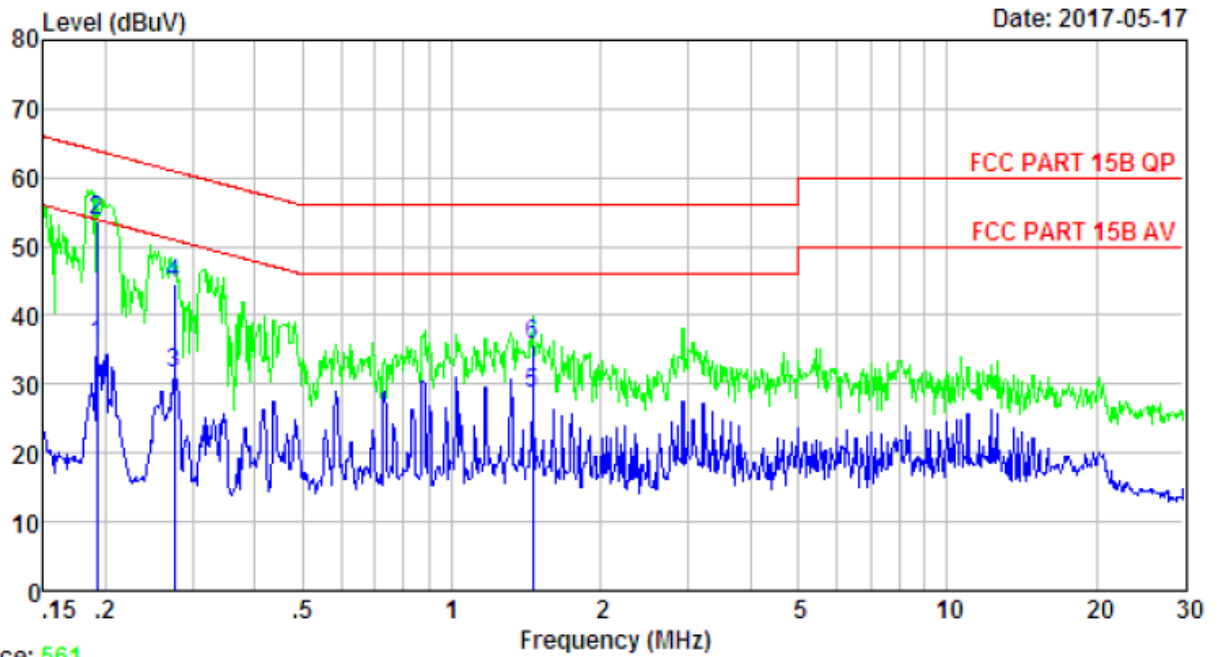

Trace: 561  
 Site no : 844 Shield Room Data no. : 562  
 Env. / Ins. : Temp:25.3'C Humi:58% Press:101.50kPa LINE Phase : NEUTRAL  
 Limit : FCC PART 15B QP  
 Engineer : Bible  
 EUT : LCD TV or LED TV  
 Power : AC 120V/60Hz  
 M/N : 32R20  
 Test Mode : HDMI (1920\*1080+Running "H"Pattern)

	Freq. (MHz)	LISN Factor (dB)	Cable Loss (dB)	Reading (dBuV)	Emission Level (dBuV)	Limits (dBuV)	Margin (dB)	Remark
1	0.19	9.58	9.80	16.36	35.74	53.93	18.19	Average
2	0.19	9.58	9.80	34.36	53.74	63.93	10.19	QP
3	0.28	9.60	9.83	12.23	31.66	50.94	19.28	Average
4	0.28	9.60	9.83	25.23	44.66	60.94	16.28	QP
5	1.46	9.62	9.83	9.22	28.67	46.00	17.33	Average
6	1.46	9.62	9.83	16.22	35.67	56.00	20.33	QP

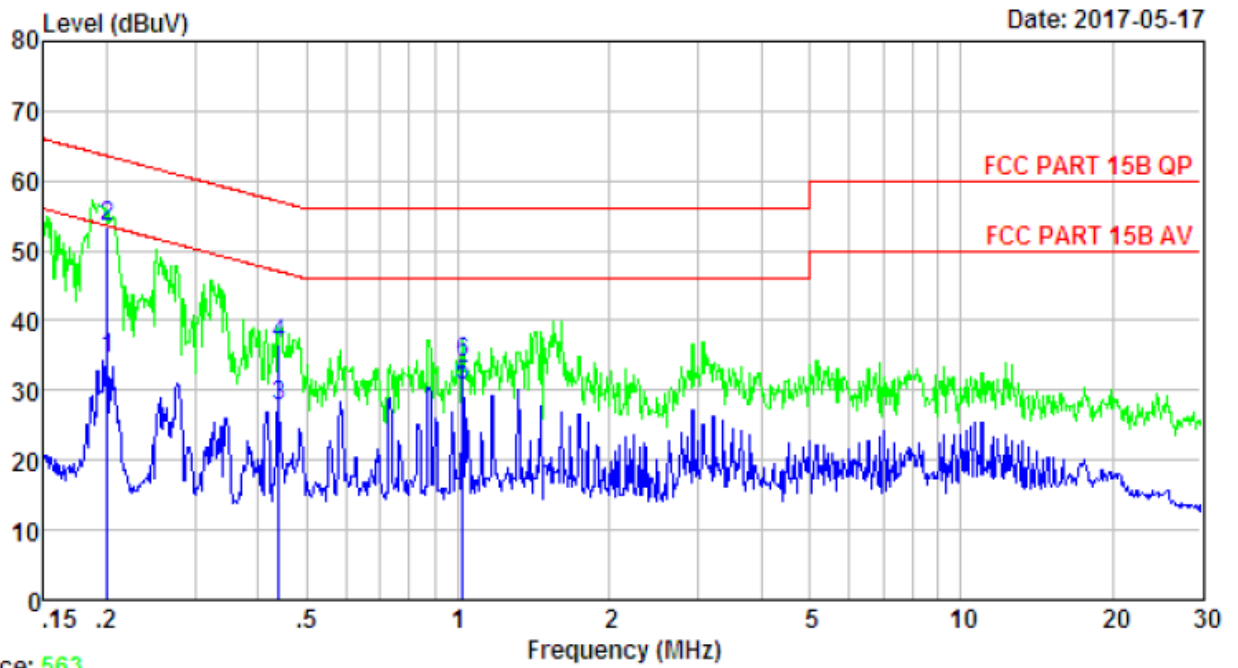

Trace: 563

Site no : 844 Shield Room Data no. : 564  
 Env. / Ins. : Temp:25.3'C Humi:58% Press:101.50kPa LINE Phase : LINE  
 Limit : FCC PART 15B QP  
 Engineer : Bible  
 EUT : LCD TV or LED TV  
 Power : AC 120V/60Hz  
 M/N : 32R20  
 Test Mode : HDMI (1920\*1080+Running "H"Pattern)

	Freq. (MHz)	LISN Factor (dB)	Cable Loss (dB)	Reading (dBuV)	Emission Level (dBuV)	Limits (dBuV)	Margin (dB)	Remark
1	0.20	9.61	9.80	15.01	34.42	53.58	19.16	Average
2	0.20	9.61	9.80	34.01	53.42	63.58	10.16	QP
3	0.44	9.61	9.81	8.22	27.64	47.07	19.43	Average
4	0.44	9.61	9.81	17.22	36.64	57.07	20.43	QP
5	1.02	9.64	9.85	11.32	30.81	46.00	15.19	Average
6	1.02	9.64	9.85	14.32	33.81	56.00	22.19	QP

## 4.2. Radiated Emission Test

**RESULT** : **Pass**  
Test Procedure : ANSI C63.4:2014  
Frequency Range : 30-1000 MHz;1-6 GHz  
Test Site : 966 Chamber  
Limits : FCC Part 15:2016 Class B

### Test Setup

Date of Test : May 15,2017~May 17,2017  
M/N : 32R20  
Input Voltage : AC 120V/60Hz  
Operation Mode : HDMI

The EUT was placed on a turn table which was 0.8 m above the ground. The turn table can rotate 360 degrees to determine the position of the maximum emission level. The EUT was set 3 m away from the receiving antenna which was mounted on an antenna tower. The measuring antenna moved up and down to find out the maximum emission level. It moved from 1 m to 4 m for both horizontal and vertical polarizations.

The EUT was tested in the Chamber Site. It was pre-scanned with a Peak detector from the spectrum, and all the final readings from the test receiver were measured with the Quasi-Peak detector.

The bandwidth setting on the test receiver was 120 kHz.

The bandwidth of the Spectrum's VBW is set at 3MHz and RBW is set at 1MHz for peak emissions measurement above 1GHz and 1MHz RBW, 10Hz VBW for average emissions measure above 1GHz

The test data of the worst case condition(s) was reported on the following page.

1、 In Semi-anechoic Chamber Test Setup Diagram for 30MHz~1000MHz

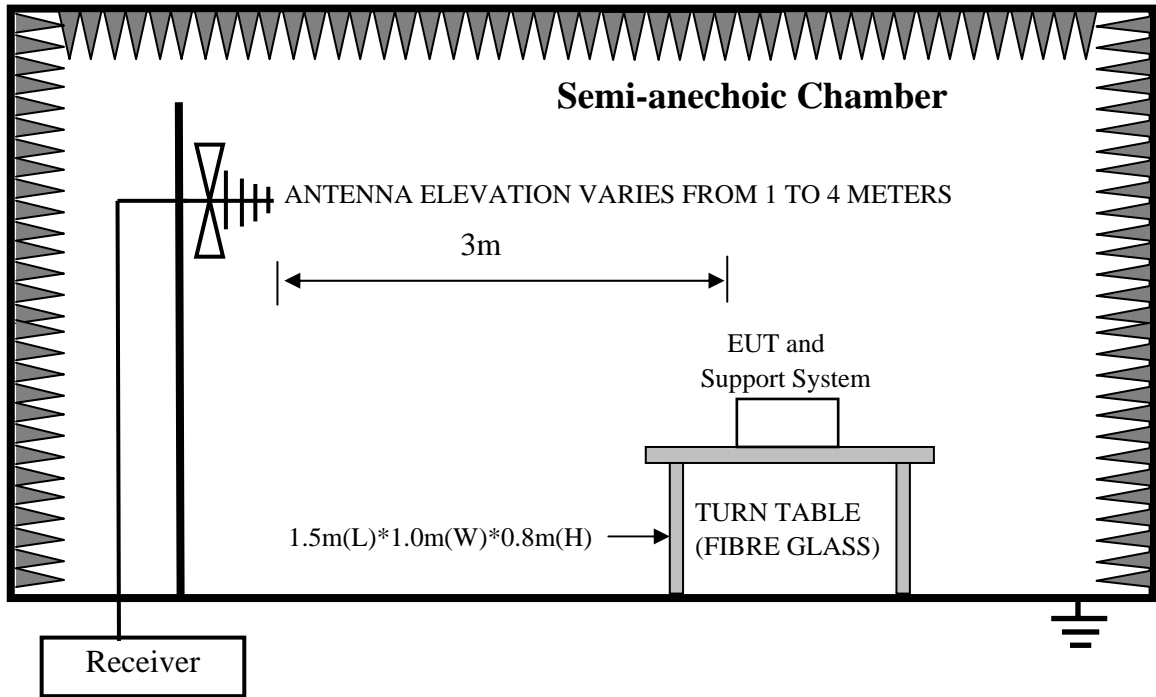

2、 In Anechoic Chamber Test Setup Diagram for 1-6GHz

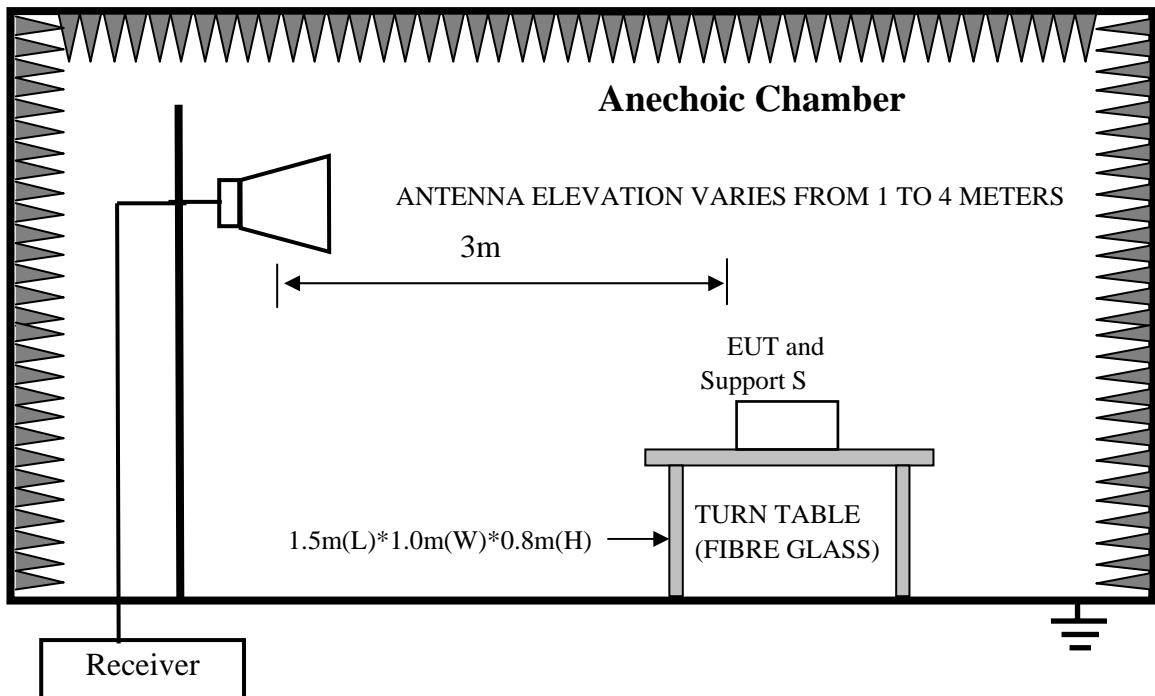

Test uncertainty:  $\pm 3.62\text{dB}$  at a level of confidence of 95%.

**Test Data**

30MHz-1GHz

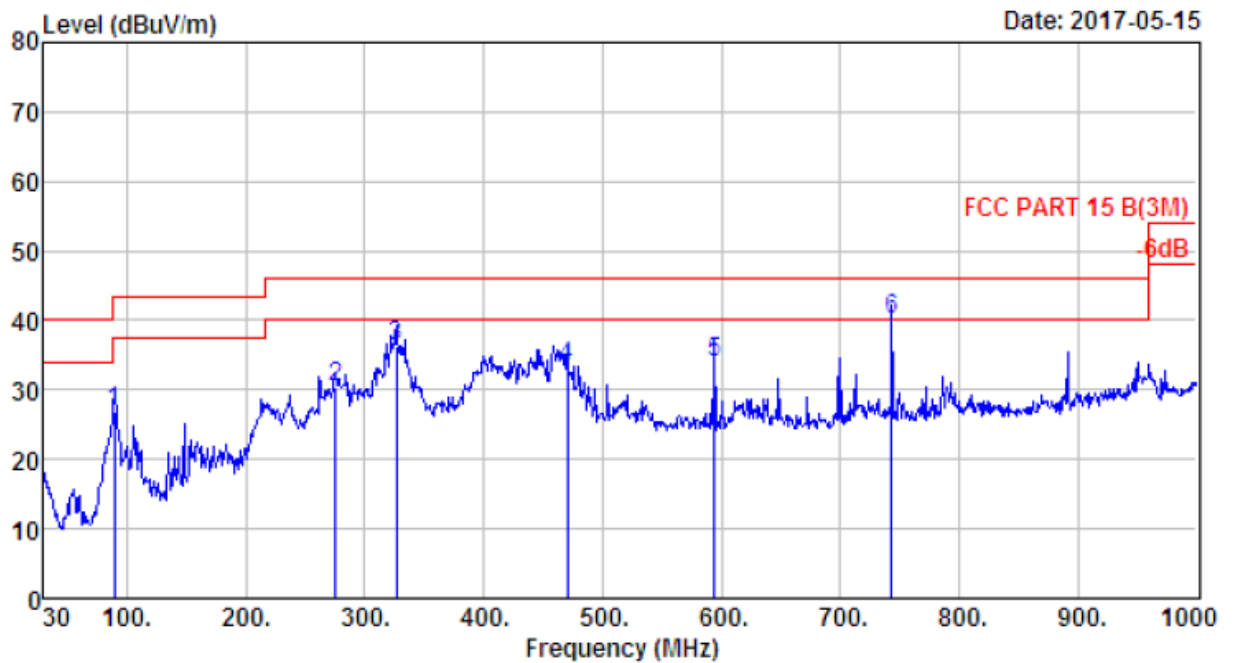

Site no. : 1# 966 Chamber                      Data no. : 96  
 Dis. / Ant. : 3m 27137                      Ant. pol. : HORIZONTAL  
 Limit : FCC PART 15 B(3M)  
 Env. / Ins. : Temp:23.6';Humi:56%;Press:101.52kPa  
 Engineer : Bible  
 EUT : LCD TV or LED TV  
 Power : AC 120V/60Hz  
 M/N : 32R20  
 Test Mode : HDMI (1920\*1080+Running "H"Pattern)

	Freq. (MHz)	ANT Factor (dB/m)	Cable Loss (dB)	Reading (dBuV)	Emission Level (dBuV/m)	Limit (dBuV/m)	Margin (dB)	Remark
1	89.170	8.24	1.32	17.23	26.79	43.50	16.71	QP
2	275.410	12.36	2.24	15.87	30.47	46.00	15.53	QP
3	326.820	13.77	2.44	20.04	36.25	46.00	9.75	QP
4	470.380	17.21	3.13	13.02	33.36	46.00	12.64	QP
5	594.540	19.51	3.33	11.22	34.06	46.00	11.94	QP
6	742.950	22.31	3.86	13.97	40.14	46.00	5.86	QP

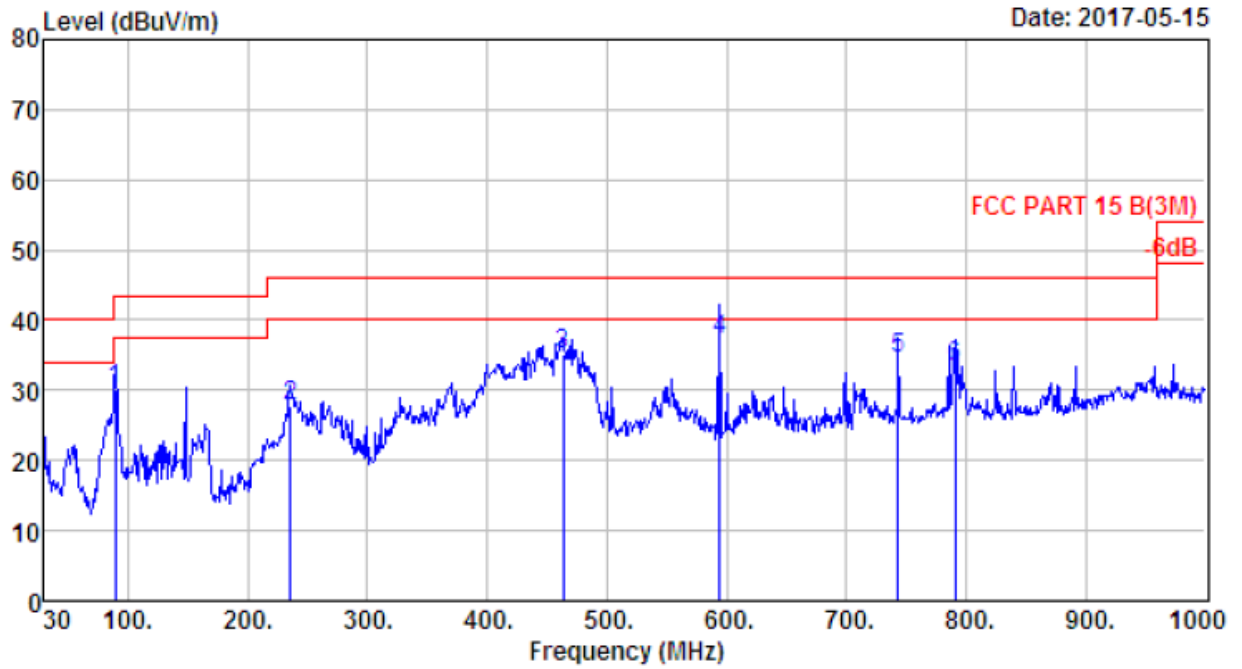

Site no. : 1# 966 Chamber  
 Dis. / Ant. : 3m 27137  
 Limit : FCC PART 15 B(3M)  
 Env. / Ins. : Temp:23.6';Humi:56%;Press:101.52kPa  
 Engineer : Bible  
 EUT : LCD TV or LED TV  
 Power : AC 120V/60Hz  
 M/N : 32R20  
 Test Mode : HDMI (1920\*1080+Running "H"Pattern)

	Freq. (MHz)	ANT Factor (dB/m)	Cable Loss (dB)	Reading (dBuV)	Emission Level (dBuV/m)	Limit (dBuV/m)	Margin (dB)	Remark
1	89.170	8.24	1.32	20.67	30.23	43.50	13.27	QP
2	235.640	9.80	2.09	15.91	27.80	46.00	18.20	QP
3	463.590	16.97	3.04	15.20	35.21	46.00	10.79	QP
4	594.010	19.51	3.34	14.30	37.15	46.00	8.85	QP
5	742.950	22.31	3.86	8.26	34.43	46.00	11.57	QP
6	790.480	22.04	3.86	7.39	33.29	46.00	12.71	QP



Above 1GHz

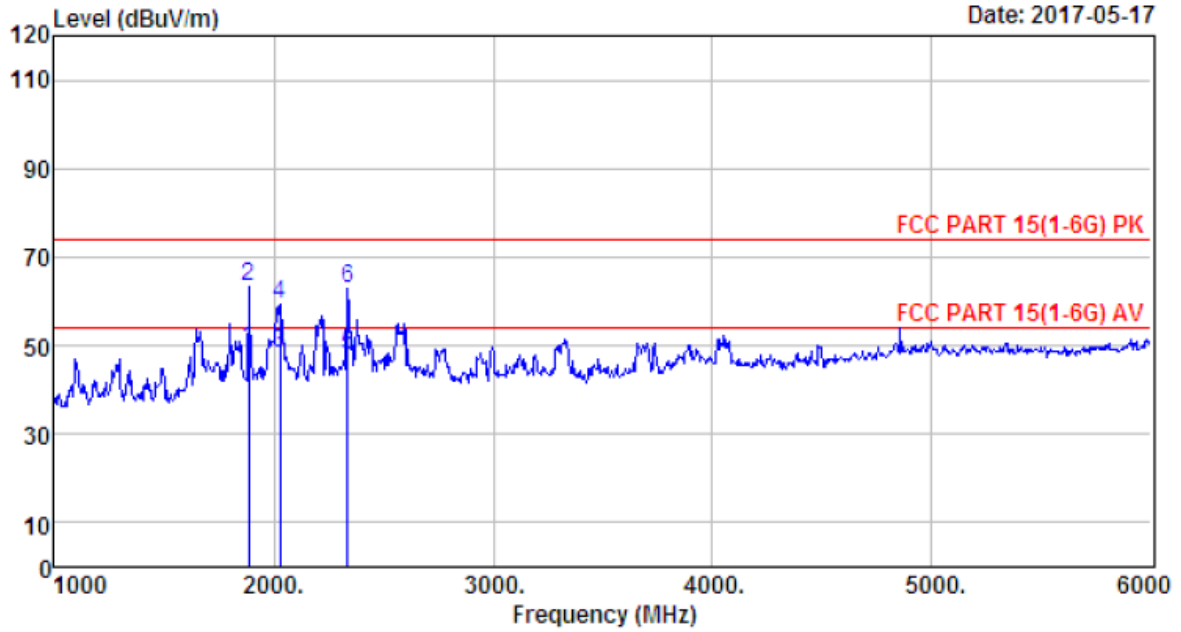

Site no. : 1# 966 Chamber Data no. : 90  
 Dis. / Ant. : 3m ANT 1-18G Ant. pol. : HORIZONTAL  
 Limit : FCC PART 15(1-6G) PK  
 Env. / Ins. : Temp:23.6';Humi:56%;Press:101.52kPa  
 Engineer : Bible  
 EUT : LCD TV or LED TV  
 Power : AC 120V/60Hz  
 M/N : 32R20  
 Test Mode : HDMI (1920\*1080+Running "H"Pattern)

	Freq. (MHz)	Ant. Factor (dB/m)	Cable Loss (dB)	Amp Factor (dB)	Reading (dBuV)	Emission Level (dBuV/m)	Limits (dBuV/m)	Margin (dB)	Remark
1	1885.00	25.28	5.75	35.23	53.55	49.35	54.00	4.65	Average
2	1885.00	25.28	5.75	35.23	67.55	63.35	74.00	10.65	Peak
3	2030.00	26.30	6.23	35.05	50.79	48.27	54.00	5.73	Average
4	2030.00	26.30	6.23	35.05	61.79	59.27	74.00	14.73	Peak
5	2335.00	27.73	6.56	34.59	48.20	47.90	54.00	6.10	Average
6	2335.00	27.73	6.56	34.59	63.20	62.90	74.00	11.10	Peak

Remarks: 1. Emission Level= Antenna Factor + Cable Loss - Amp Factor + Reading.  
 2. The emission levels that are 20dB below the official limit are not reported.

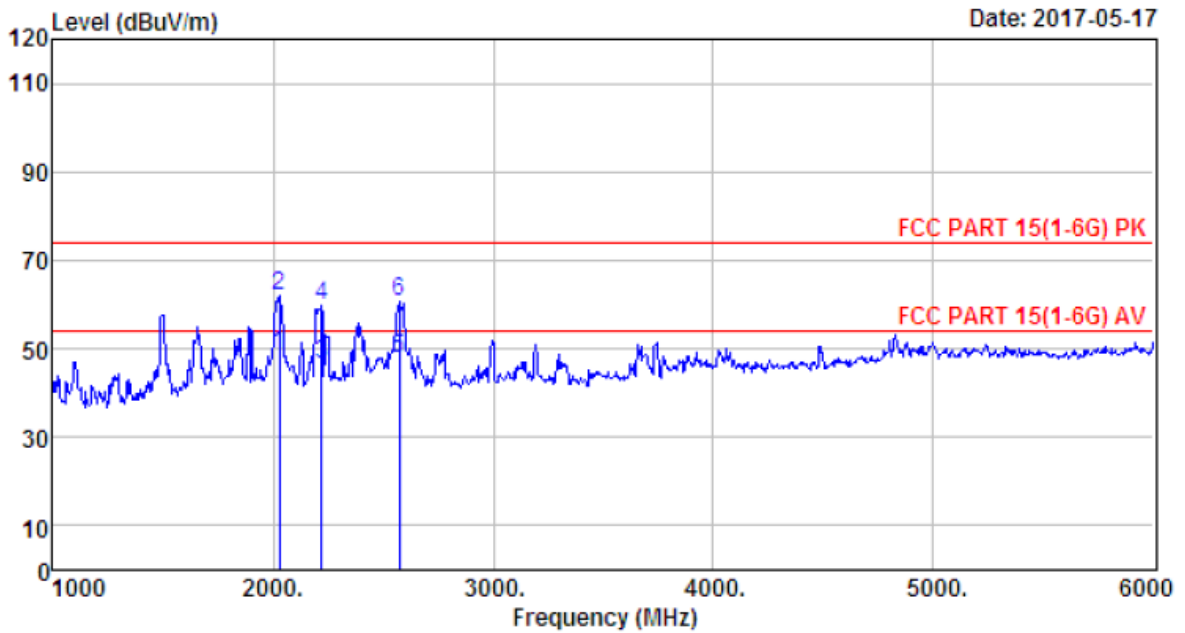

Site no. : 1# 966 Chamber                      Data no. : 91  
 Dis. / Ant. : 3m ANT 1-18G                      Ant. pol. : VERTICAL  
 Limit : FCC PART 15(1-6G) PK  
 Env. / Ins. : Temp:23.6';Humi:56%;Press:101.52kPa  
 Engineer : Bible  
 EUT : LCD TV or LED TV  
 Power : AC 120V/60Hz  
 M/N : 32R20  
 Test Mode : HDMI (1920\*1080+Running "H"Pattern)

	Freq. (MHz)	Ant. Factor (dB/m)	Cable Loss (dB)	Amp Factor (dB)	Reading (dBuV)	Emission Level (dBuV/m)	Limits (dBuV/m)	Margin (dB)	Remark
1	2030.00	26.30	6.23	35.05	51.35	48.83	54.00	5.17	Average
2	2030.00	26.30	6.23	35.05	64.35	61.83	74.00	12.17	Peak
3	2220.00	27.81	6.43	34.79	47.24	46.69	54.00	7.31	Average
4	2220.00	27.81	6.43	34.79	60.24	59.69	74.00	14.31	Peak
5	2575.00	27.68	7.12	35.86	48.82	47.76	54.00	6.24	Average
6	2575.00	27.68	7.12	35.86	61.82	60.76	74.00	13.24	Peak

Remarks: 1. Emission Level= Antenna Factor + Cable Loss - Amp Factor + Reading.  
 2. The emission levels that are 20dB below the official limit are not reported.



## 5. PHOTOGRAPHS OF TEST SET-UP

### 5.1. Set-up for conducted emission at the mains terminals test



5.2. Set-up for radiated emission test (30-1000MHz)

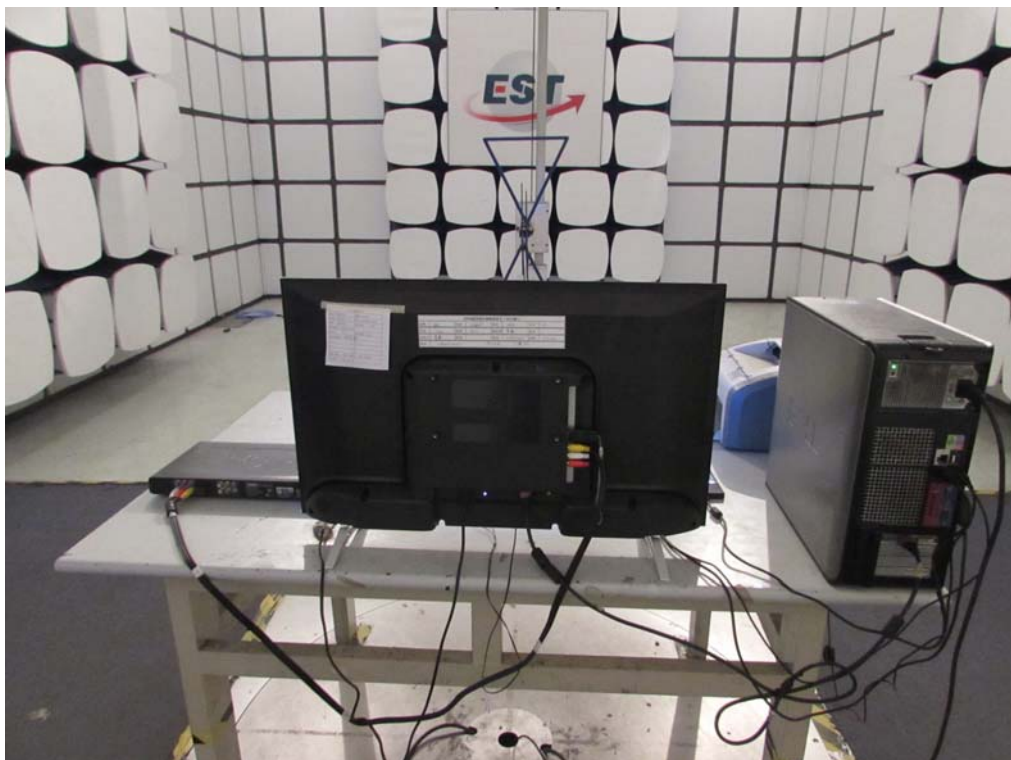
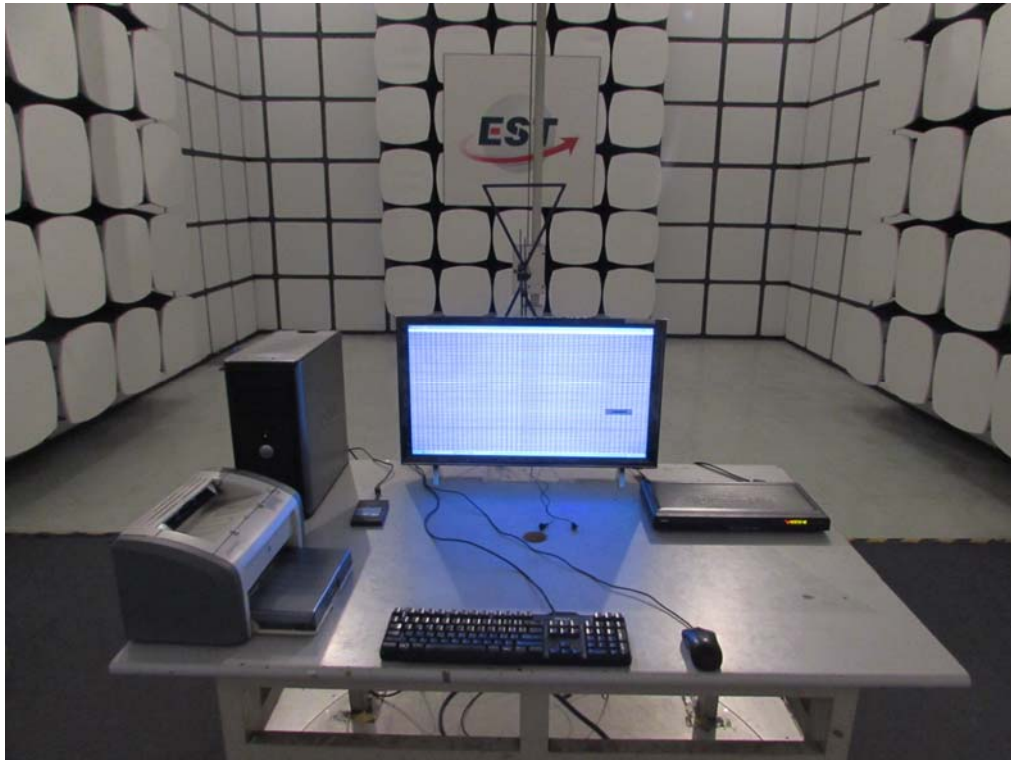

### 5.3. Set-up for radiated emission test (Above 1GHz)



## 6. PHOTOGRAPHS OF THE EUT

External Photos  
M/N: 32R20



**External Photos**  
**M/N: 32R20**



**External Photos**  
**M/N: 32R20**

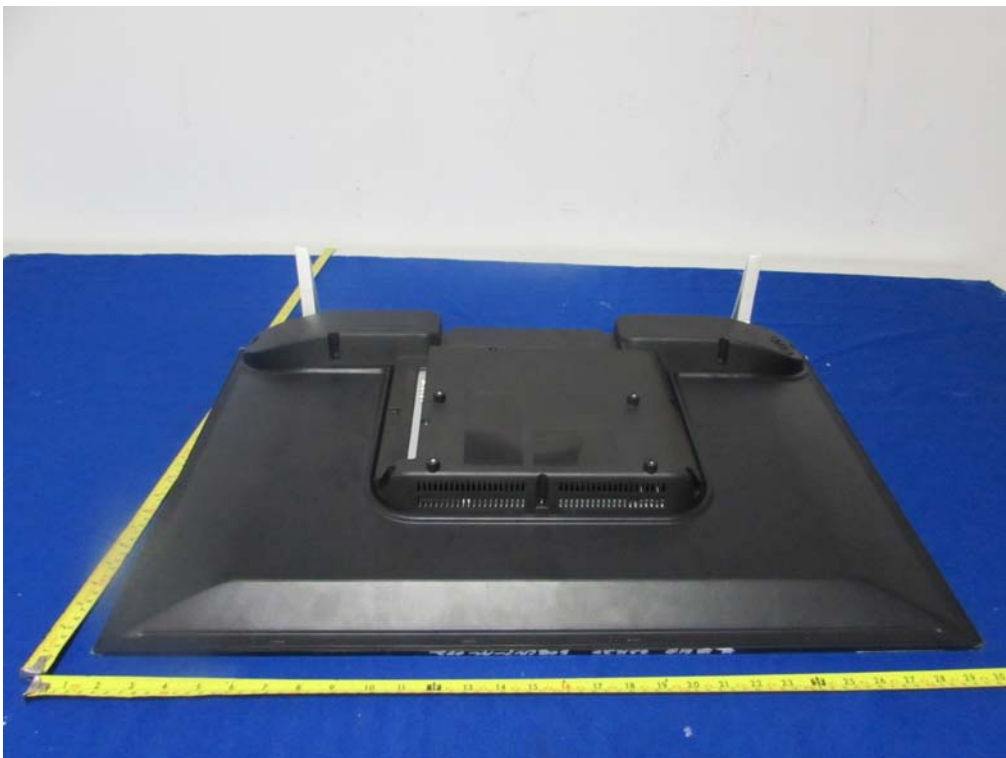



**External Photos**  
M/N: 32R20



**Internal Photos**  
**M/N: 32R20**

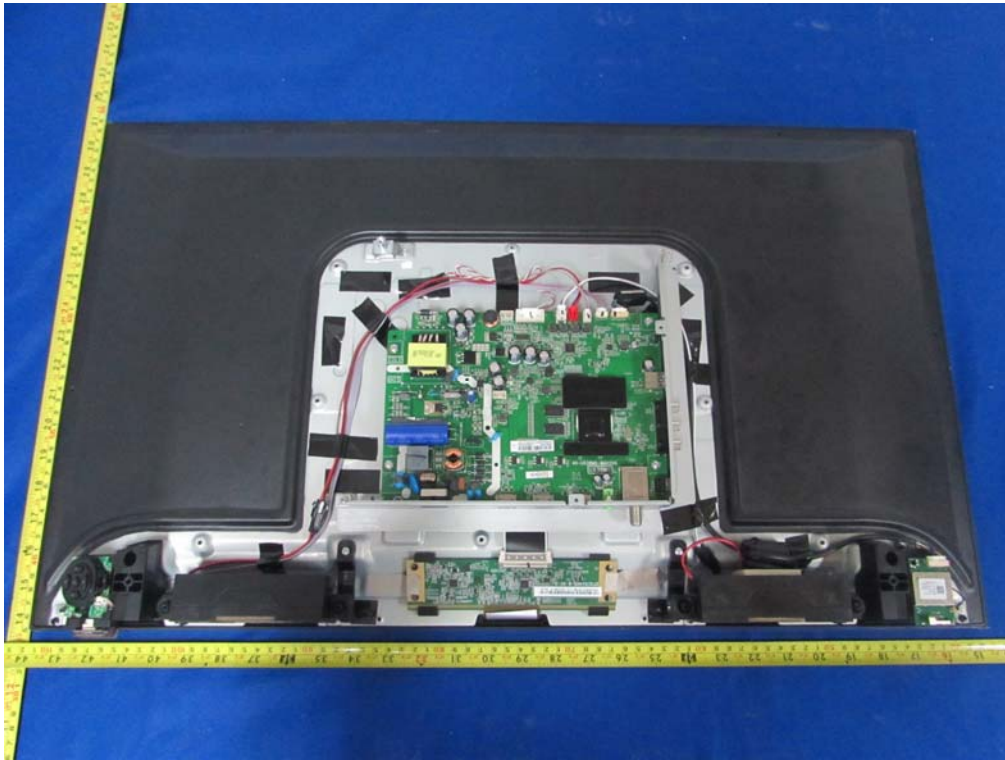

**Internal Photos**  
**M/N: 32R20**

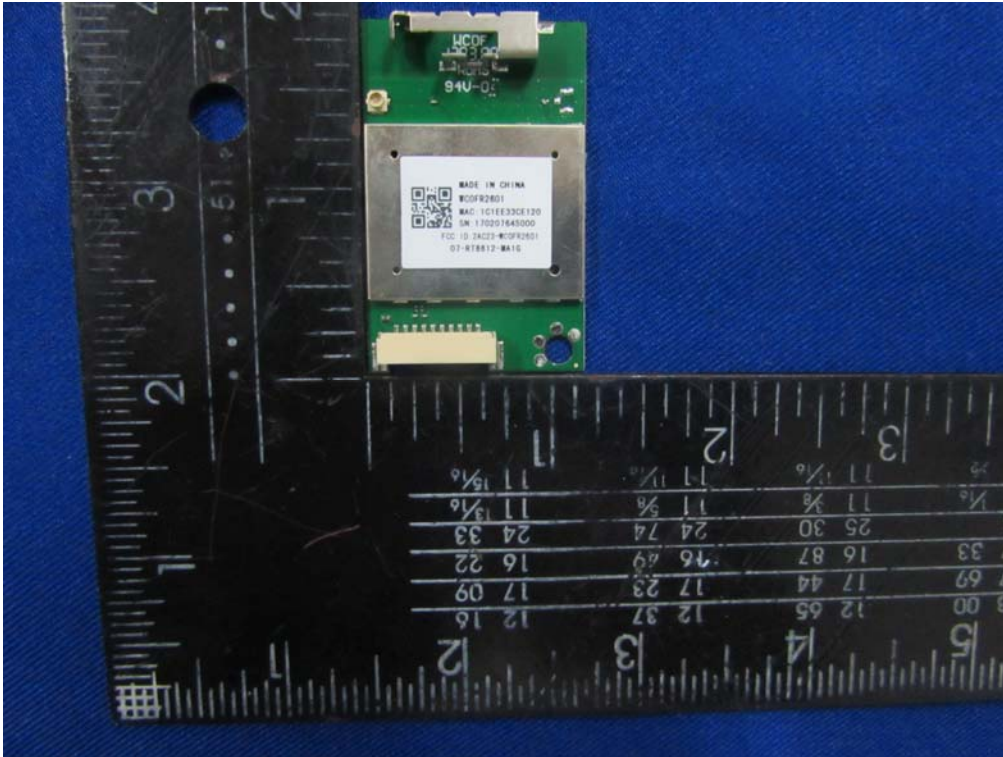
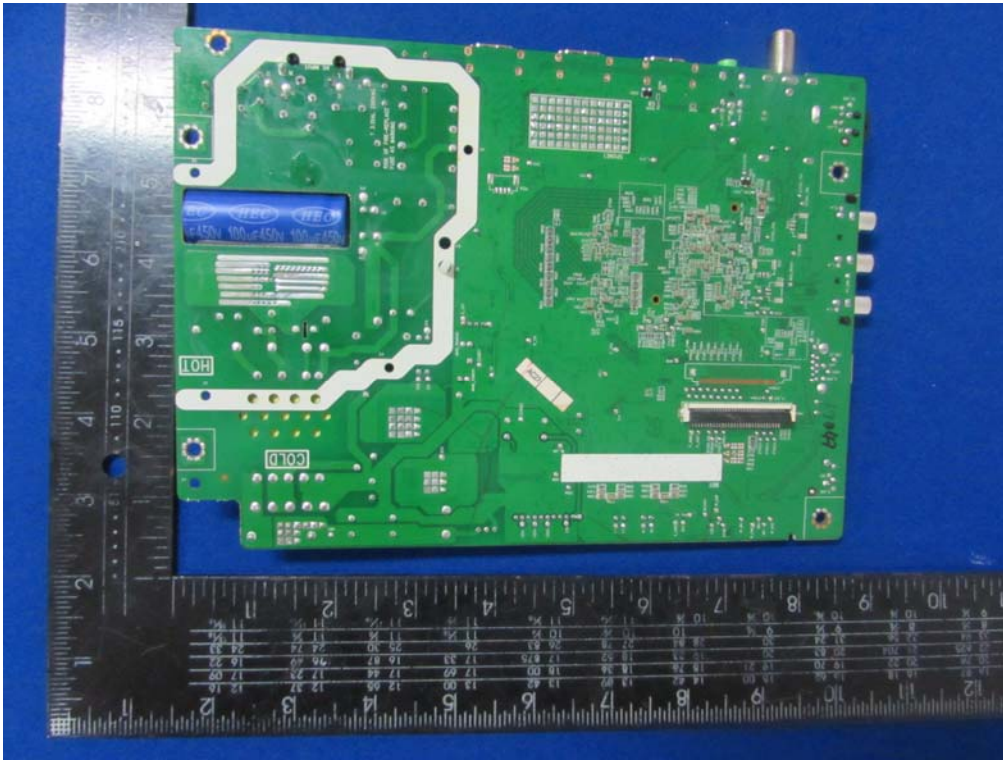

**Internal Photos**  
**M/N: 32R20**

