

TEST REPORT

Test report no.: 1-3800/11-01-02-B



Testing laboratory

CETECOM ICT Services GmbH
 Untertuerkheimer Strasse 6 – 10
 66117 Saarbruecken / Germany
 Phone: + 49 681 5 98 - 0
 Fax: + 49 681 5 98 - 9075
 Internet: <http://www.cetecom.com>
 e-mail: ict@cetecom.com

Accredited Testing Laboratory:

The testing laboratory (area of testing) is accredited according to DIN EN ISO/IEC 17025 (2005) by the Deutsche Akkreditierungsstelle GmbH (DAkkS). The accreditation is valid for the scope of testing procedures as stated in the accreditation certificate with the registration number: D-PL-12076-01-01
 Area of Testing: Radio/Satellite Communications

Applicant

STEINEL GmbH
 Dieselstr. 80 - 84
 33442 Herzebrock-Clarholz / GERMANY
 Phone: +49 (0) 5245 4 48-2 27
 Fax: +49(0)5245 448 -173
 Contact: Klaus Wenners
 e-mail: klaus.wenners@steinel.de
 Phone: +49(0)5245 448 -276

Manufacturer

Steinel Solutions AG
 Allmeindstraße 10
 8840 Einsiedeln / SWITZERLAND

Test standard/s

47 CFR Part 15	Title 47 of the Code of Federal Regulations; Chapter I Part 15 - Radio frequency devices
RSS - 210 Issue 8	Spectrum Management and Telecommunications - Radio Standards Specification Low-power Licence-exempt Radiocommunication Devices (All Frequency Bands): Category I Equipment

For further applied test standards please refer to section 3 of this test report.

Test Item

Kind of test item:	5.8 GHz Radar
Model name:	SIR13
FCC ID:	W8J-SIR13
IC:	8529A-SIR13
Frequency:	5785 MHz – 5815 MHz
Antenna:	λ/4 dipole (1.2 cm)
Power Supply:	5.00 V DC from battery or power supply
Temperature Range:	-20 °C to +55 °C

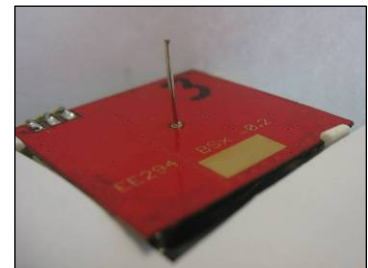

This test report is electronically signed and valid without handwriting signature. For verification of the electronic signatures, the public keys can be requested at the testing laboratory.

Test report authorised:

Karsten Gerdaldy
 Senior Testing Manager

Test performed:

Meheza Walla
 Expert

1 Table of contents

1	Table of contents	2
2	General information	3
2.1	Notes and disclaimer	3
2.2	Application details	3
3	Test standard/s	3
4	Test environment	4
5	Test item	4
6	Test laboratories sub-contracted	4
7	Summary of measurement results	5
8	RF measurement testing	6
8.1	Description of test setup	6
8.1.1	Radiated measurements	6
8.1.2	Additional comments	7
9	Measurement results	8
9.1	Field strength of emissions (wanted signal)	8
9.2	Occupied bandwidth	11
9.3	Field strength of emissions (radiated spurious)	15
9.4	Conducted spurious emissions < 30 MHz	21
10	Test equipment and ancillaries used for tests	23
11	Observations	24
Annex A	Photographs of the test setup	25
Annex B	External photographs of the EUT	27
Annex C	Internal photographs of the EUT	28
Annex D	Document history	30
Annex E	Further information	30
Annex F	Accreditation Certificate	31

2 General information

2.1 Notes and disclaimer

The test results of this test report relate exclusively to the test item specified in this test report. CETECOM ICT Services GmbH does not assume responsibility for any conclusions and generalizations drawn from the test results with regard to other specimens or samples of the type of the equipment represented by the test item.

The test report may only be reproduced or published in full. Reproduction or publication of extracts from the report requires the prior written approval of CETECOM ICT Services GmbH.

The testing service provided by CETECOM ICT Services GmbH has been rendered under the current "General Terms and Conditions for CETECOM ICT Services GmbH".

CETECOM ICT Services GmbH will not be liable for any loss or damage resulting from false, inaccurate, inappropriate or incomplete product information provided by the customer.

Under no circumstances does the CETECOM ICT Services GmbH test report include any endorsement or warranty regarding the functionality, quality or performance of any other product or service provided.

Under no circumstances does the CETECOM ICT Services GmbH test report include or imply any product or service warranties from CETECOM ICT Services GmbH, including, without limitation, any implied warranties of merchantability, fitness for purpose, or non-infringement, all of which are expressly disclaimed by CETECOM ICT Services GmbH.

All rights and remedies regarding vendor's products and services for which CETECOM ICT Services GmbH has prepared this test report shall be provided by the party offering such products or services and not by CETECOM ICT Services GmbH.

In no case this test report can be considered as a Letter of Approval.

This test report is electronically signed and valid without handwritten signature. For verification of the electronic signatures, the public keys can be requested at the testing laboratory.

2.2 Application details

Date of receipt of order:	2011-10-28
Date of receipt of test item:	2012-02-01
Start of test:	2012-02-01
End of test:	2012-02-18
Person(s) present during the test:	-/-

3 Test standard/s

Test standard	Date	Test standard description
47 CFR Part 15	2010-10	Title 47 of the Code of Federal Regulations; Chapter I Part 15 - Radio frequency devices
RSS - 210 Issue 8	2010-12	Spectrum Management and Telecommunications - Radio Standards Specification Low-power Licence-exempt Radiocommunication Devices (All Frequency Bands): Category I Equipment

4 Test environment

Temperature:	T_{nom}	+22 °C during room temperature tests
Relative humidity content:		55 %
Barometric pressure:		not relevant for this kind of testing
Power supply:	V_{nom}	5.00 V DC from battery or power supply
	V_{max}	5.75 V
	V_{min}	4.25 V

5 Test item

Kind of test item	:	5.8 GHz Radar
Type identification	:	SIR13
S/N serial number	:	None
HW hardware status	:	None
SW software status	:	None
Frequency band	:	5785 MHz – 5815 MHz
Type of modulation	:	Unmodulated Carrier
Number of channels	:	1
Antenna	:	$\lambda/4$ dipole (1.2 cm)
Power supply	:	5.00 V DC from battery or power supply
Temperature range	:	+22 °C (Test performed under normal test conditions)

6 Test laboratories sub-contracted

None

7 Summary of measurement results

- No deviations from the technical specifications were ascertained**
- There were deviations from the technical specifications ascertained

TC Identifier	Description	Verdict	Date	Remark
RF-Testing	47 CFR Part 15 RSS 210, Issue 8, Annex 7	Passed	2012-05-04	-/-

Test specification clause	Test case	Temperature conditions	Power source voltages	Pass	Fail	NA	NP	Results (max.)
§15.245(b) RSS 210 / A7.1	Field strength of emissions (wanted signal)	Nominal	Nominal	<input checked="" type="checkbox"/>	<input type="checkbox"/>	<input type="checkbox"/>	<input type="checkbox"/>	94.21 dBµV @ 3 m
§2.1049	Occupied bandwidth (99% bandwidth)	Nominal	Nominal	<input checked="" type="checkbox"/>	<input type="checkbox"/>	<input type="checkbox"/>	<input type="checkbox"/>	3.19 MHz
§15.209(a) / §15.245(b)(1)(2)(3) RSS 210 / A7.1-4	Field strength of emissions (spurious)	Nominal	Nominal	<input checked="" type="checkbox"/>	<input type="checkbox"/>	<input type="checkbox"/>	<input type="checkbox"/>	complies
§15.207(a) ICES-003	Conducted emissions < 30 MHz	Nominal	Nominal	<input checked="" type="checkbox"/>	<input type="checkbox"/>	<input type="checkbox"/>	<input type="checkbox"/>	complies

Note: NA = Not Applicable; NP = Not Performed

8 RF measurement testing

8.1 Description of test setup

8.1.1 Radiated measurements

The radiated measurements are performed in vertical and horizontal plane in the frequency range from 9 kHz to 25 GHz in semi-anechoic chambers. The EUT is positioned on a non-conductive support with a height of 0.80 m above a conductive ground plane that covers the whole chamber. The receiving antennas are confirmed with specifications ANSI C63.2-1996 clause 15 and ANSI C63.4-2009 clause 4.1.5. These antennas can be moved over the height range between 1.0 m and 4.0 m in order to search for maximum field strength emitted from EUT. The measurement distances between EUT and receiving antennas are indicated in the test setups for the various frequency ranges. For each measurement, the EUT is rotated in all three axes until the maximum field strength is received. The wanted and unwanted emissions are received by spectrum analyzers where the detector modes and resolution bandwidths over various frequency ranges are set according to requirement ANSI C63-4-2009 clause 4.2.

Antennas are confirmed with ANSI C63.2-1996 item 15.

Semi anechoic chamber

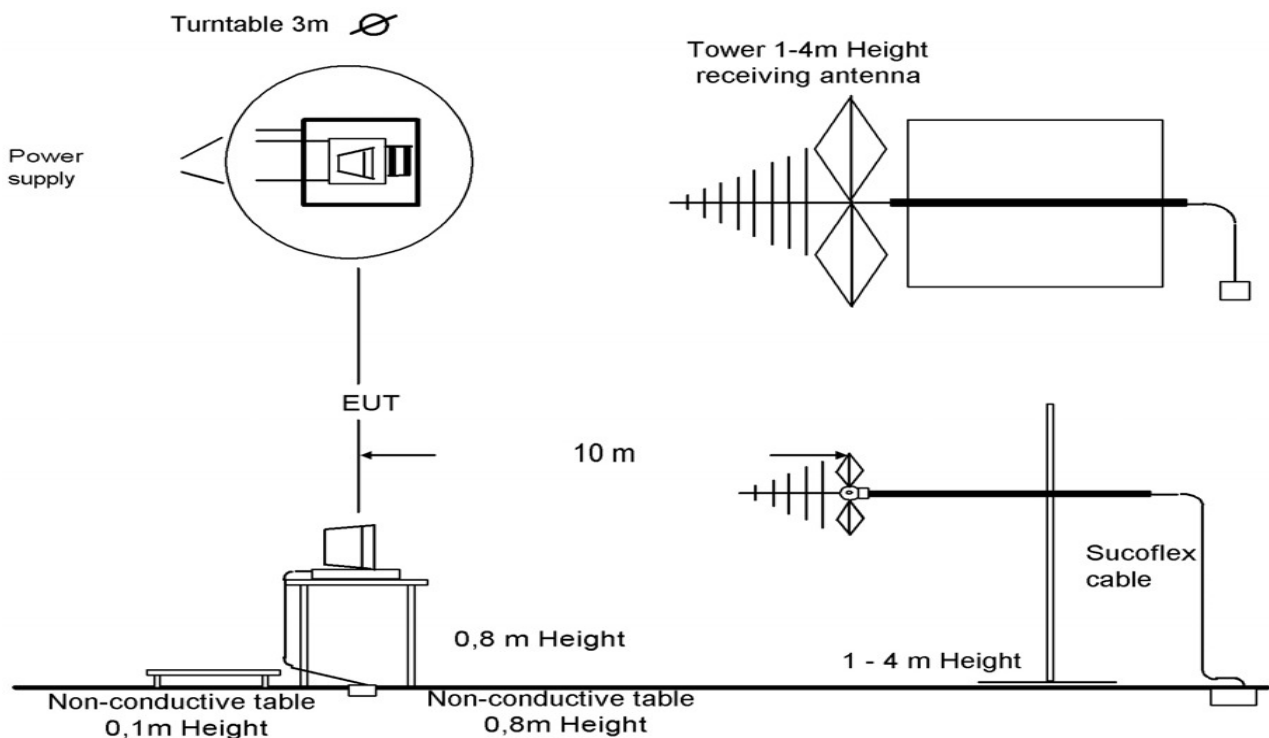

Picture 1: Diagram radiated measurements

9 kHz - 30 MHz:	active loop antenna
30 MHz – 1 GHz:	tri-log antenna
> 1 GHz:	horn antenna

The EUT is powered by an external power supply with nominal voltage

8.1.2 Additional comments

Reference documents: None

Special test descriptions: None

Configuration descriptions: None

Test mode: Normal operation, no special test mode available.

Special software is used.

9 Measurement results

9.1 Field strength of emissions (wanted signal)

Description:

Measurement of the maximum radiated field strength of the wanted signal.

Plot 1: T_{nom} / V_{nom}

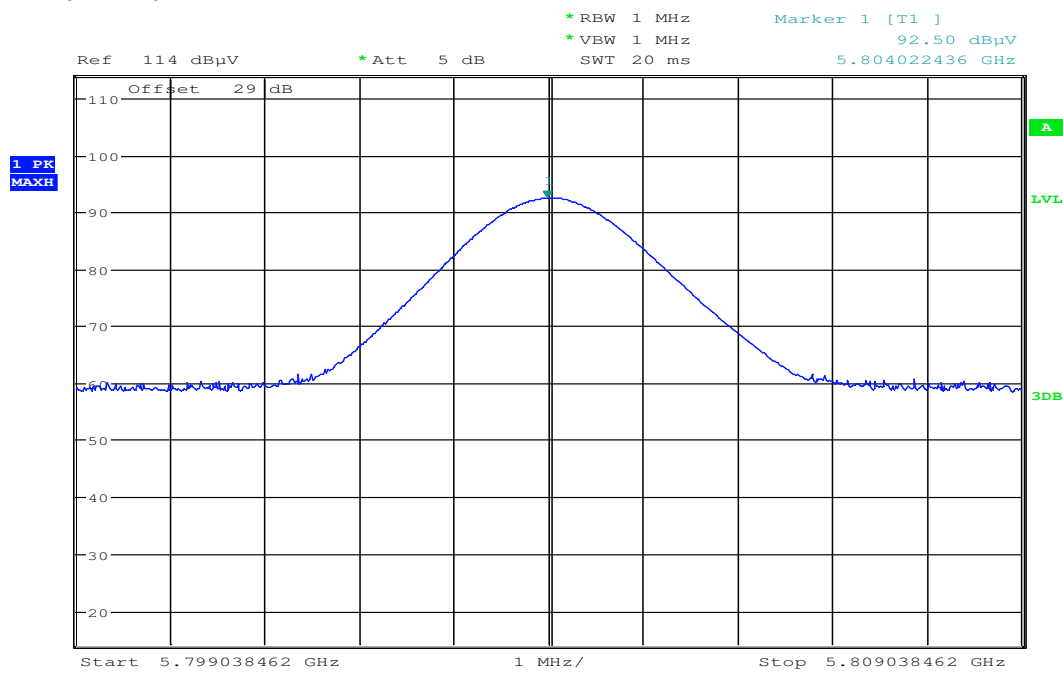

Date: 2.FEB.2012 06:48:28

Plot 2: T_{nom} / V_{max}

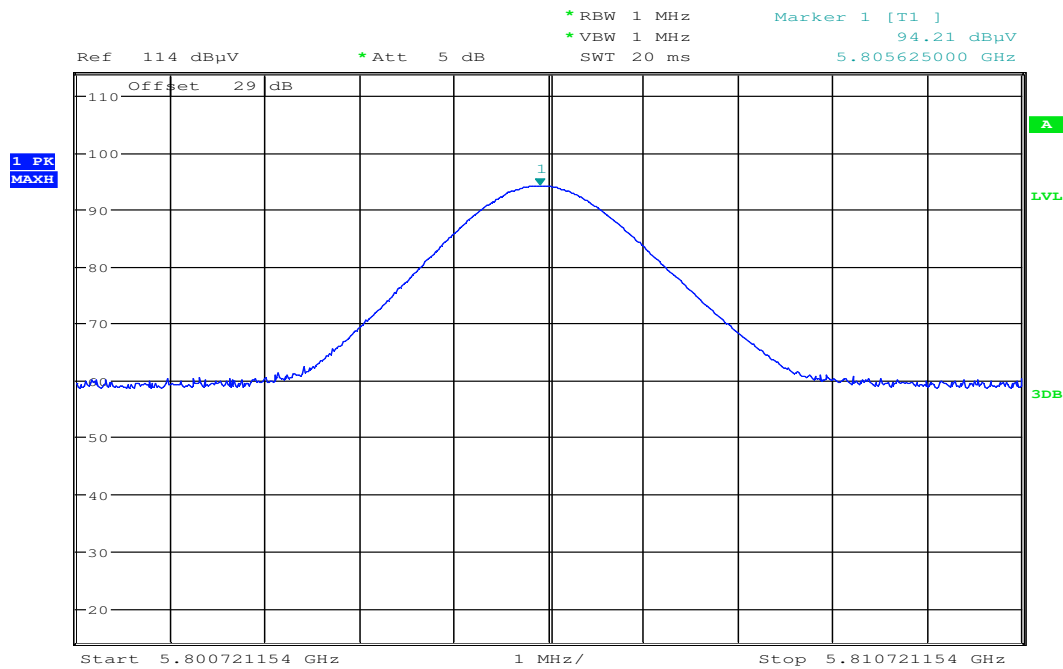

Date: 2.FEB.2012 06:57:15

Plot 3: T_{nom} / V_{min}

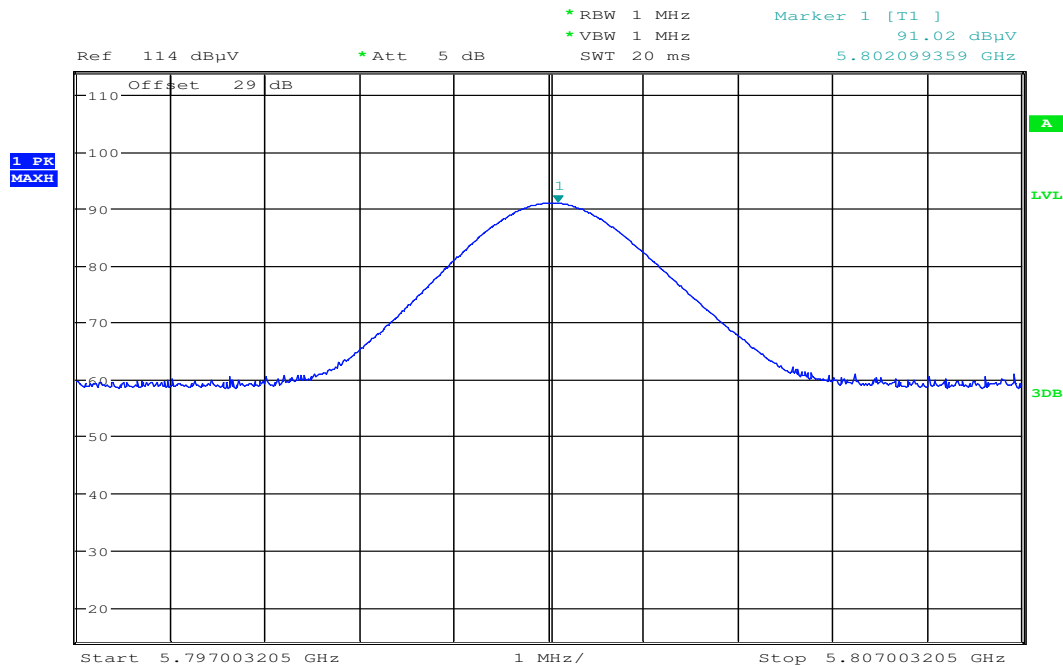

Date: 2.FEB.2012 06:54:25

Result:

Test condition	Maximum field strength [dB μ V/m] @ 3 m
T _{nom} / V _{nom}	92.50
T _{nom} / V _{max}	94.21
T _{nom} / V _{min}	91.02
Measurement uncertainty	± 3 dB

Limits:

FCC		IC
CFR Part 15.245(b)		RSS - 210, Annex 7
Field strength of emissions		
The field strength of emissions from intentional radiators operated within these frequency bands shall comply with the following:		
Frequency [GHz]	Field Strength [dB μ V/m]	Measurement distance
5.785 – 5.815	114	3

The measurement is passed

9.2 Occupied bandwidth

Plot 4: 99% Bandwidth, T_{nom} / V_{nom}

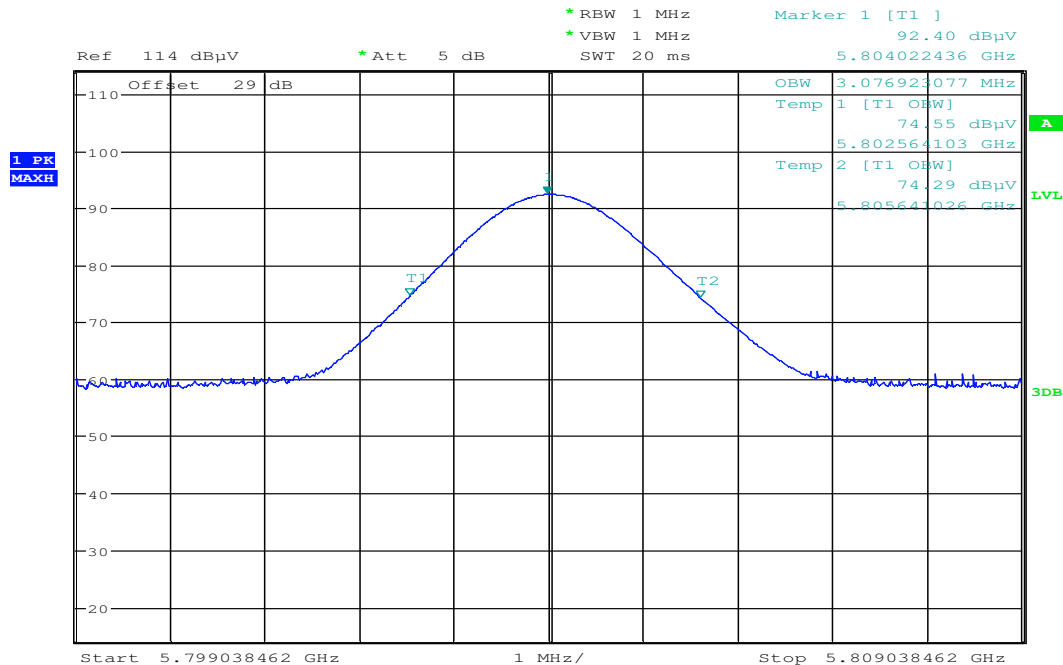

Date: 2.FEB.2012 06:49:25

Plot 5: 99% Bandwidth, T_{nom} / V_{max}

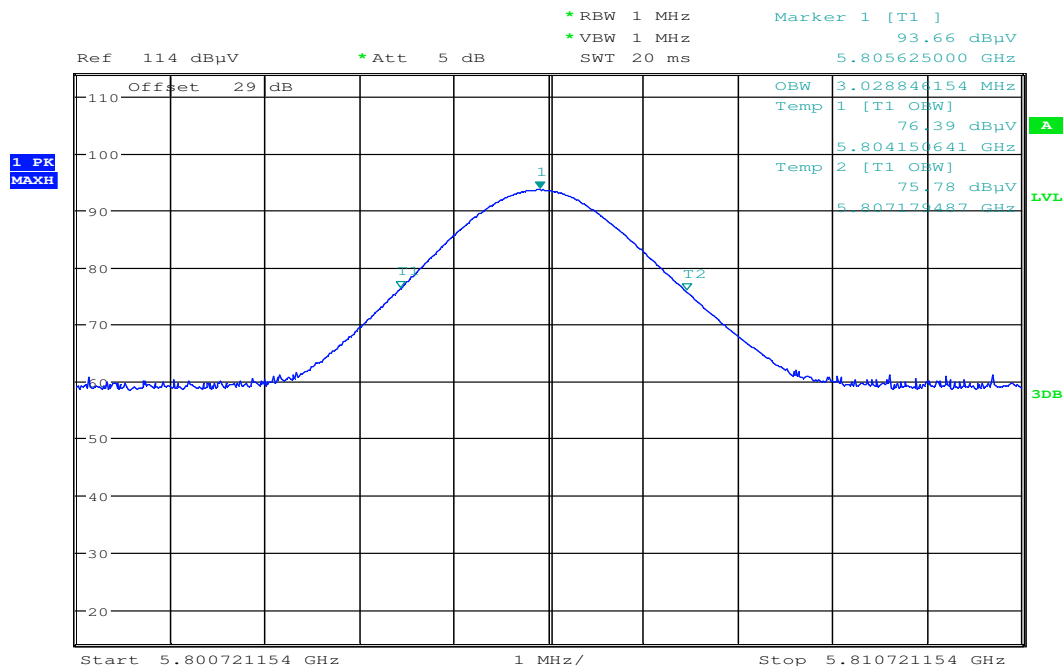

Date: 2.FEB.2012 06:58:14

Plot 6: 99% Bandwidth, T_{nom} / V_{min}

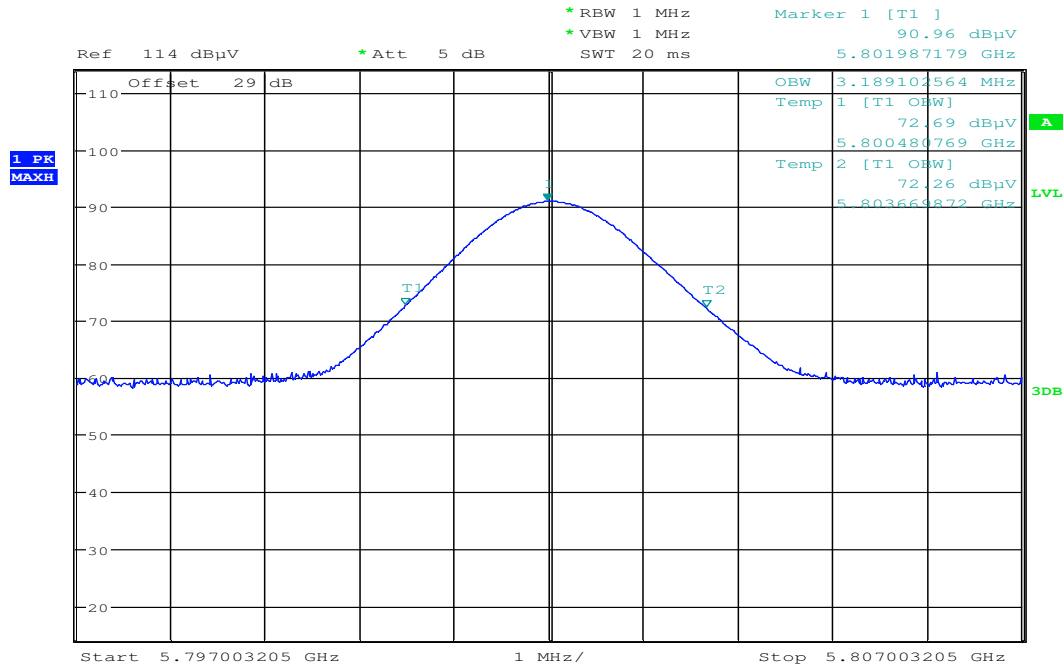

Date: 2.FEB.2012 06:53:20

Plot 7: 26 dB Bandwidth, T_{nom} / V_{nom}

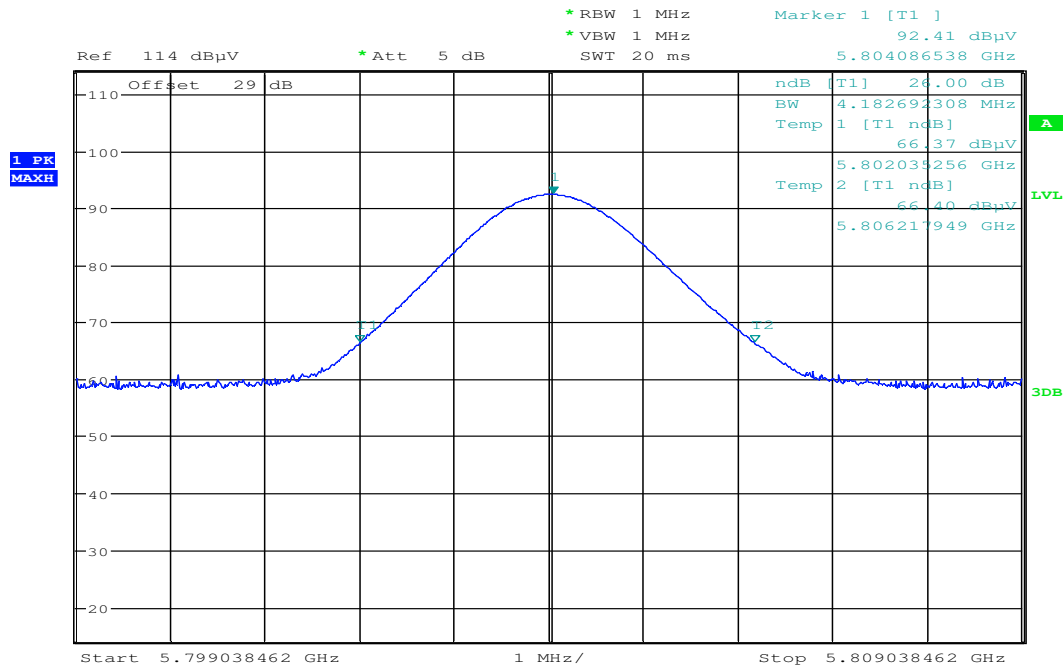

Date: 2.FEB.2012 06:50:04

Plot 8: 26 dB Bandwidth, T_{nom} / V_{max}

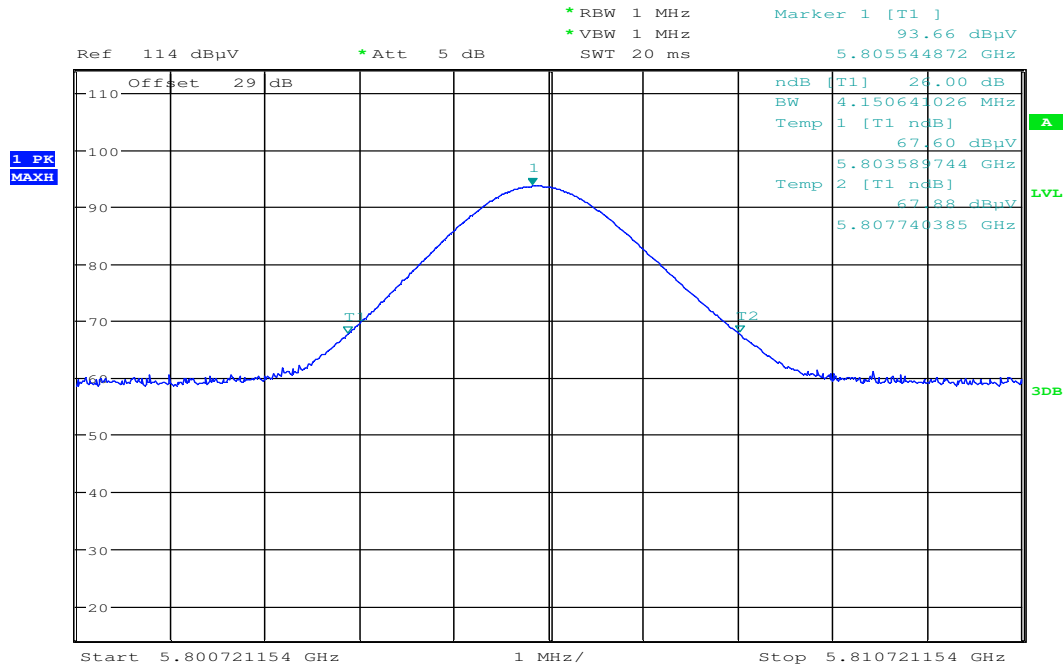

Date: 2.FEB.2012 06:59:22

Plot 9: 26 dB Bandwidth, T_{nom} / V_{min}

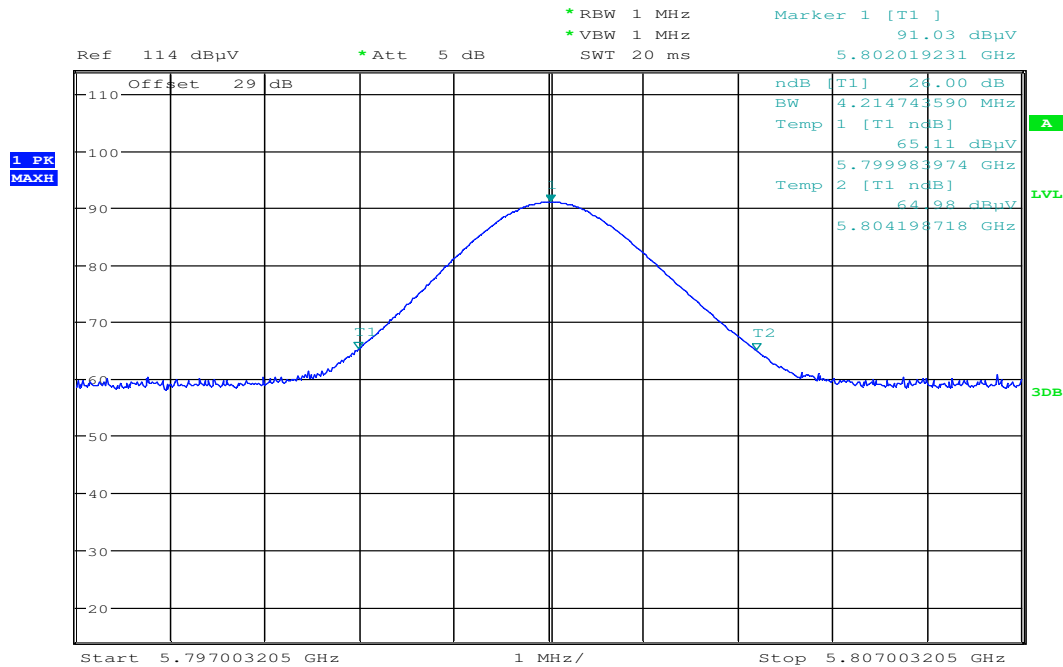

Date: 2.FEB.2012 06:52:21

Result:

Test condition	99 % Occupied Bandwidth [MHz]
$T_{\text{nom}} / V_{\text{nom}}$	3.08
$T_{\text{nom}} / V_{\text{max}}$	3.03
$T_{\text{nom}} / V_{\text{min}}$	3.19
Measurement uncertainty	± 3 dB

Test condition	26 dB Occupied Bandwidth [MHz]
$T_{\text{nom}} / V_{\text{nom}}$	4.18
$T_{\text{nom}} / V_{\text{max}}$	4.15
$T_{\text{nom}} / V_{\text{min}}$	4.21
Measurement uncertainty	± 3 dB

The measurement is passed

9.3 Field strength of emissions (radiated spurious)

Description:

Measurement of the radiated spurious emissions in transmit mode.

Measurement:

Measurement parameter	
Detector:	Peak / Quasi Peak
Sweep time:	Auto
Video bandwidth:	Auto
Resolution bandwidth:	F < 1 GHz: 100 kHz F > 1 GHz: 1 MHz
Frequency range:	30 MHz to 40 GHz
Trace-Mode:	Max Hold

Limits:

FCC		IC	
CFR Part 15.209(a)		RSS - GEN	
Radiated Spurious Emissions			
Emissions radiated outside of the specified frequency bands, except for harmonics, shall be attenuated by at least 50 dB below the level of the fundamental or to the general radiated emission limits in § 15.209, whichever is the lesser attenuation.			
Frequency (MHz)	Field Strength (dB μ V/m)	Measurement distance	
0.009 – 0.490	2400/F(kHz)	300	
0.490 – 1.705	24000/F(kHz)	30	
1.705 – 30.0	30	30	
30 – 88	30.0	10	
88 – 216	33.5	10	
216 – 960	36.0	10	
Above 960	54.0	3	

Note: Harmonics shall not exceed 1.6 millivolts/meter (64.0 dB μ V/m)

Results:

TX Spurious Emissions Radiated [dBμV/m]								
SR13			-/-			-/-		
F [GHz]	Detector	Level [dBμV/m]	F [MHz]	Detector	Level [dBμV/m]	F [MHz]	Detector	Level [dBμV/m]
23.23	Peak	55.38						
29.03	Peak	62.35						
34.84	Peak	50.74						
Measurement uncertainty			± 3 dB					

The measurement is passed.

Plot 10: Traffic mode up to 30 MHz

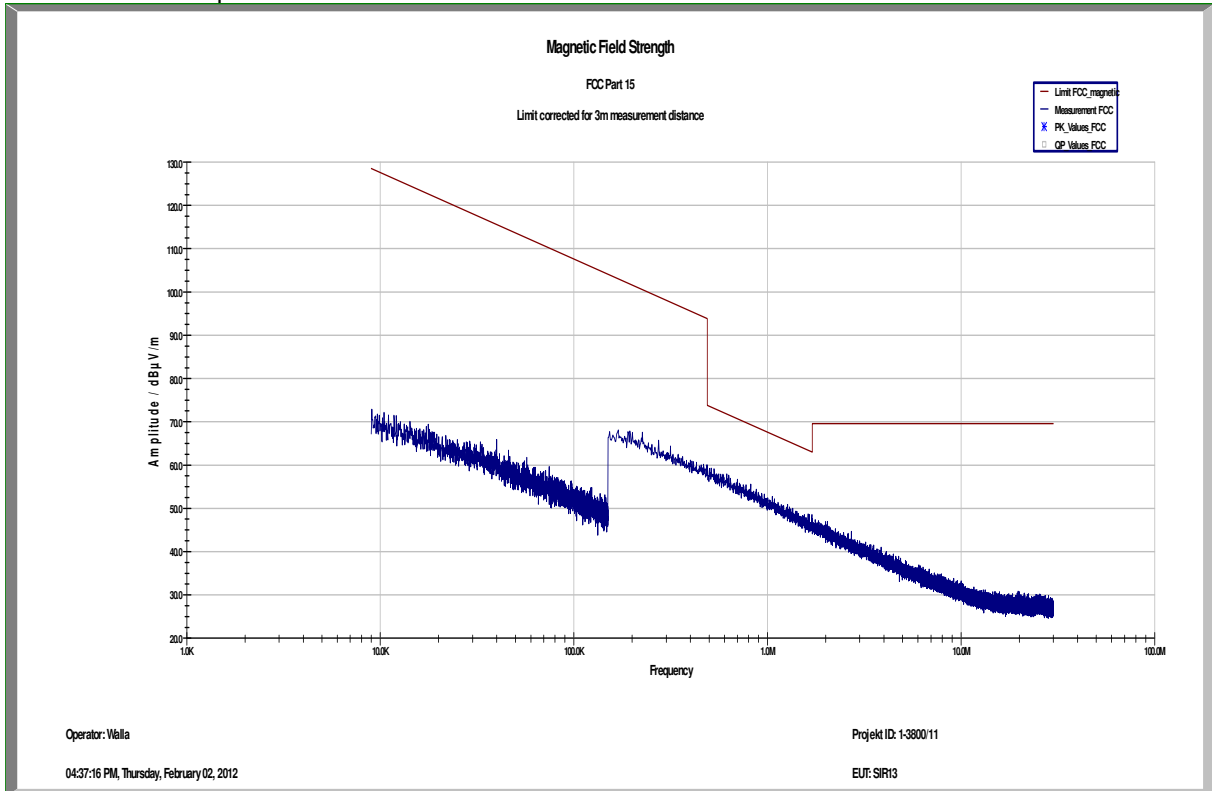

Plot 11: 30 MHz to 1 GHz, vertical / horizontal polarization

EUT:	SIR13
Serial Number:	unknown
Test Description:	FCC class B @ 10 m
Operating Conditions:	TX-Mode
Operator Name:	Hennemann
Comment:	DC: 5 V

Scan Setup: STAN_Fin [EMI radiated]

Hardware Setup:	Electric Field (NOS)
Receiver:	[ESCI 3]
Level Unit:	dBµV/m

Subrange	Step Size	Detectors	IF BW	Meas. Time	Preamp
30 MHz - 2 GHz	60 kHz	QPK	120 kHz	1 s	20 dB

FCC_10m(B)

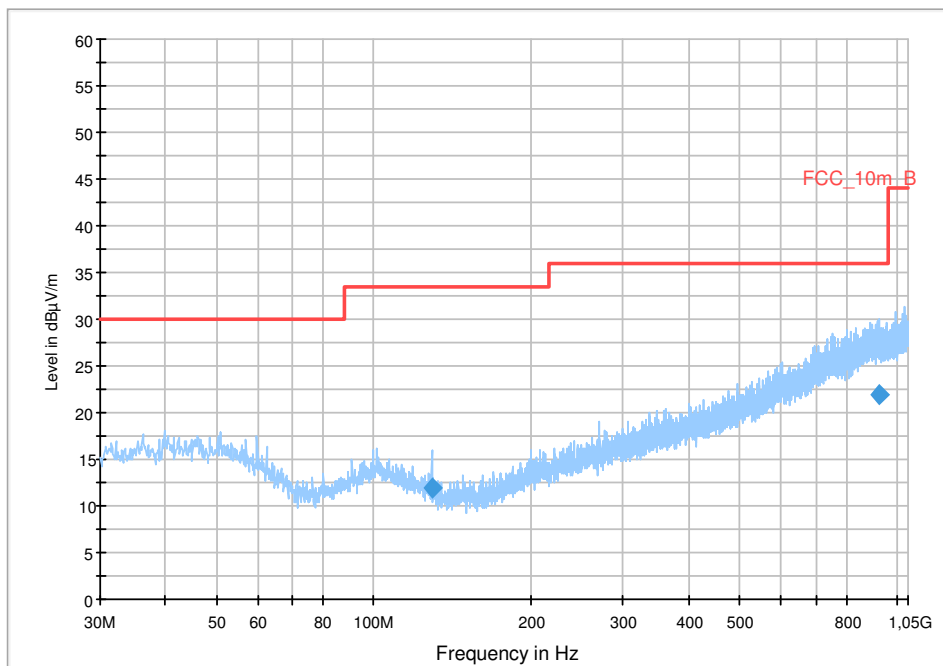

Frequency (MHz)	QuasiPeak (dBµV/m)	Meas. Time (ms)	Bandwidth (kHz)	Height (cm)	Polarization	Azimuth (deg)	Corr. (dB)	Margin (dB)	Limit (dBµV/m)
129.058200	11.9	1000.0	120.000	198.0	V	146.0	9.5	21.6	33.5
928.179750	22.0	1000.0	120.000	400.0	V	82.0	25.3	14.0	36.0

Plot 12: 1 GHz to 18 GHz, vertical / horizontal polarization

EUT:	SIR13
Serial Number:	unknown
Test Description:	FCC class B
Operating Conditions:	TX-Mode
Operator Name:	Hennemann
Comment:	DC: 5 V

FCC_1_18_B_oH

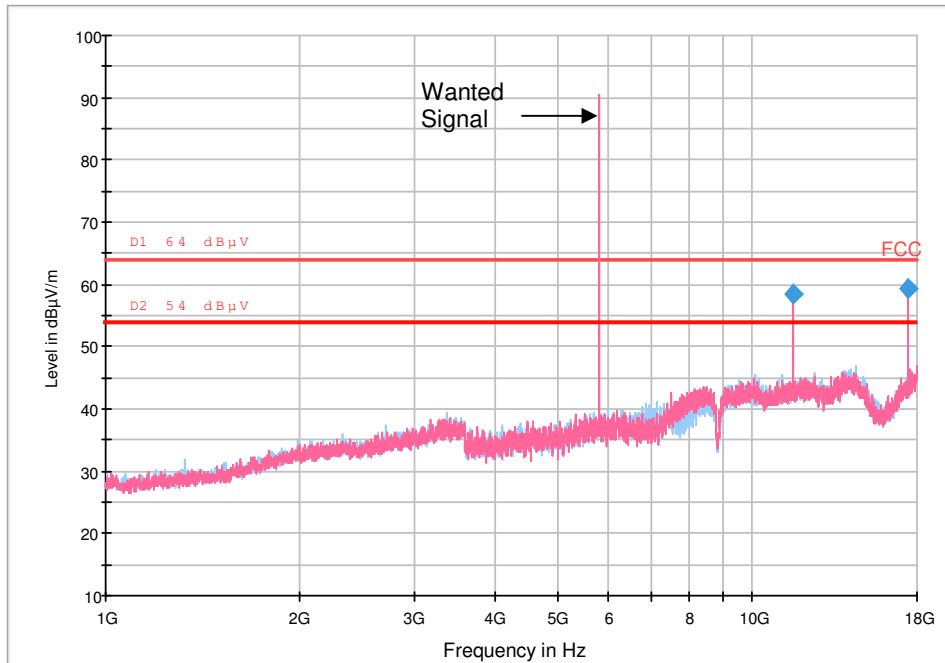

Frequency (MHz)	Average (dBµV/m)	Meas. Time (ms)	Bandwidth (kHz)	Height (cm)	Polarization	Azimuth (deg)	Corr. (dB)	Margin (dB)	Limit (dBµV/m)
11608.713597	58.6	3000.0	1000.000	100.0	V	23.0	4.9	5.4	64.0
17413.086427	59.5	3000.0	1000.000	100.0	V	209.0	9.3	4.5	64.0

Plot 13: 18 GHz to 26 GHz, vertical / horizontal polarization

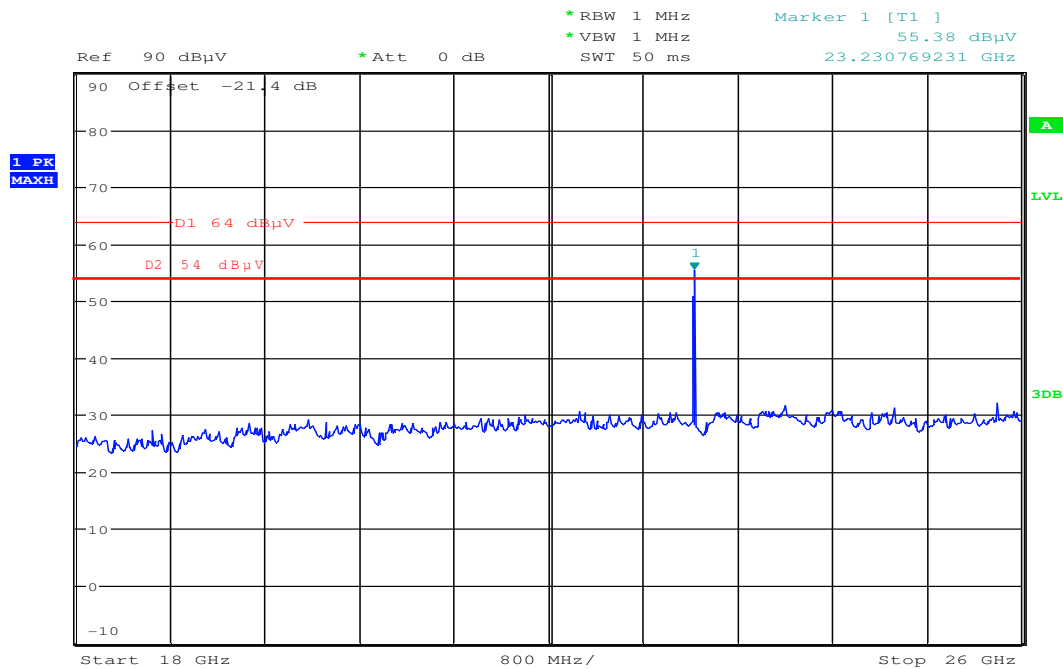

Date: 2.FEB.2012 08:09:19

Plot 14: 26 GHz to 40 GHz, vertical / horizontal polarization

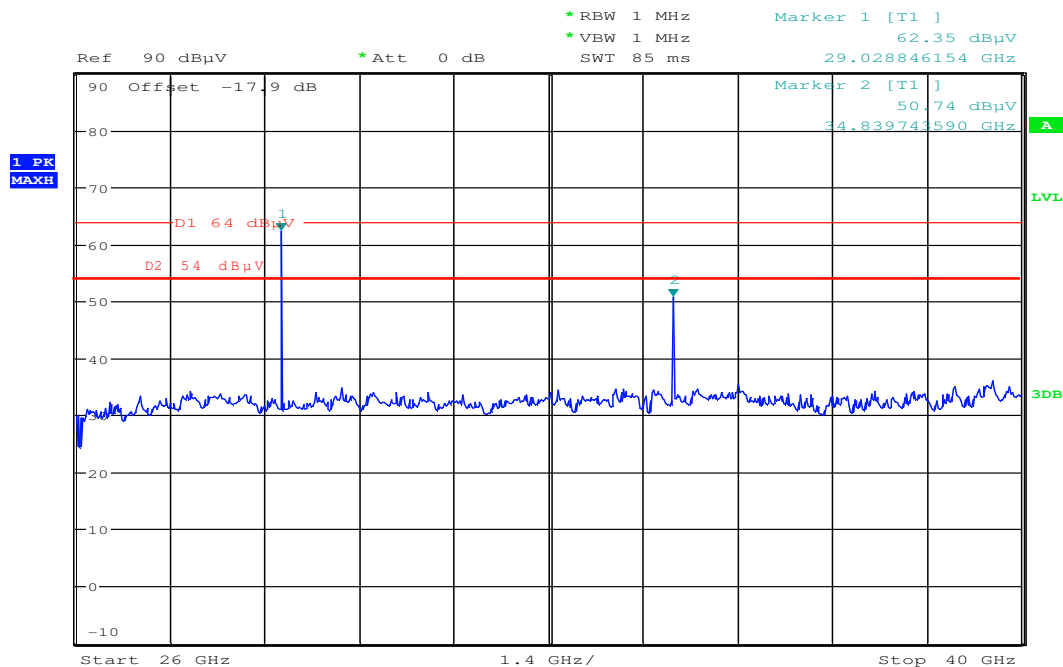

Date: 2.FEB.2012 08:36:14

9.4 Conducted spurious emissions < 30 MHz

Description:

Measurement of the conducted spurious emissions in transmit mode below 30 MHz. Both power lines, phase and neutral line, are measured. Found peaks are re-measured with average and quasi peak detection to show compliance to the limits.

Measurement:

Measurement parameter	
Detector:	Peak - Quasi Peak / Average
Sweep time:	Auto
Video bandwidth:	F < 150 kHz: 200 Hz F > 150 kHz: 9 kHz
Resolution bandwidth:	F < 150 kHz: 1 kHz F > 150 kHz: 100 kHz
Span:	9 kHz to 30 MHz
Trace-Mode:	Max Hold

Limits:

FCC		IC	
CFR Part 15.207(a)		ICES-003, Issue 4	
Conducted Spurious Emissions < 30 MHz			
Frequency (MHz)	Quasi-Peak (dB μ V/m)	Average (dB μ V/m)	
0.15 – 0.5	66 to 56*	56 to 46*	
0.5 – 5	56	46	
5 – 30.0	60	50	

*Decreases with the logarithm of the frequency

Results:

Conducted Spurious Emissions < 30 MHz [dB μ V/m]		
F [MHz]	Detector	Level [dB μ V/m]
No critical peaks detected!		
Measurement uncertainty	± 3 dB	

The measurement is passed

Plot 15: Phase line

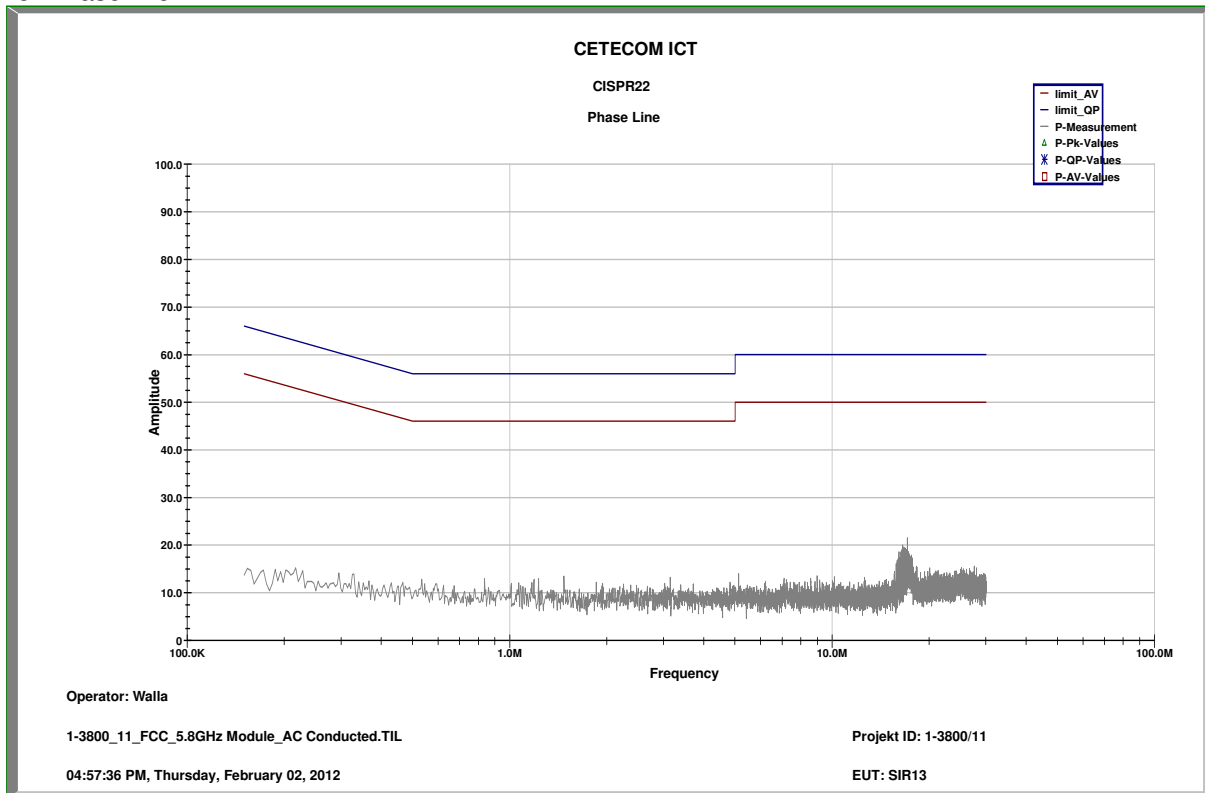

Plot 16: Neutral line

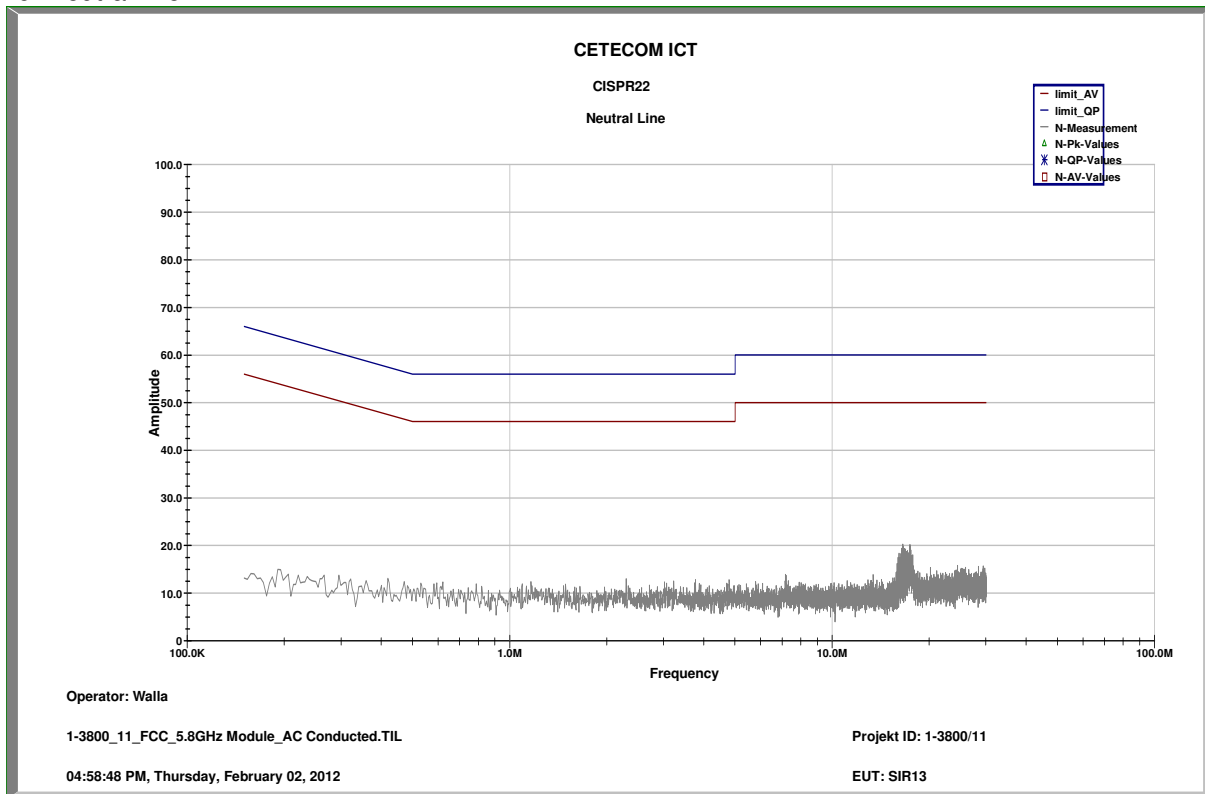

10 Test equipment and ancillaries used for tests

Typically, the calibrations of the test apparatus are commissioned to and performed by an accredited calibration laboratory. The calibration intervals are determined in accordance with the DIN EN ISO/IEC 17025. In addition to the external calibrations, the laboratory executes comparison measurements with other calibrated test systems or effective verifications. Weekly chamber inspections and range calibrations are performed. Where possible, rf-generating and signalling equipment as well as measuring receivers and analyzers are connected to an external high-precision 10 MHz reference (GPS-based or rubidium frequency standard).

In order to simplify the identification of the equipment used at some special tests, some items of test equipment and ancillaries can be provided with an identifier or number in the equipment list below (Labor/Item).

No.	Lab / Item	Equipment	Type	Manufact.	Serial No.	INV. No Cetecom	Kind of Calibration	Last Calibration	Next Calibration
1	n. a.	Isolating Transformer	RT5A	Grundig	8041	300001626	g		
2	n. a.	DC power supply, 60Vdc, 50A, 1200 W	6032A	HP Meßtechnik	2818A03450	300001040	Ve	12.01.2012	12.01.2015
3	n. a.	Coaxial Attenuator 30dB/500W	8325	Bird	1530	300001595	ev		
4	n. a.	Double-Ridged Waveguide Horn Antenna 1-18.0GHz	3115	EMCO	8812-3088	300001032	vIKI!	11.05.2011	11.05.2013
5	n. a.	Active Loop Antenna	6502	EMCO	2210	300001015	ne		
6	n. a.	Anechoic chamber	FAC 3/5m	MWB / TDK	87400/02	300000996		23.03.2009	
7	Spec.A. 2_2e	System rack for EMI measurement solution	85900	HP I.V.	*	300000222	ne		
8	9	Artificial Mains 9 kHz to 30 MHz	ESH3-Z5	R&S	828576/020	300001210	Ve	06.01.2012	06.01.2014
9	n. a.	Relais Matrix	3488A	HP Meßtechnik	2719A15013	300001156	ne		
10	n. a.	Relais Matrix	PSU	R&S	890167/024	300001168	ne		
11	n. a.	Isolating Transformer	RT5A	Grundig	9242	300001263	ne		
12	n. a.	Three-Way Power Splitter, 50 Ohm	11850C	HP Meßtechnik		300000997	ne		
13	n. a.	Switch / Control Unit	3488A	HP	2605e08770	300001443	ne		
14	n. a.	Amplifier	js42-00502650-28-5a	Parzich GMBH	928979	300003143	ne		
15	n. a.	Band Reject filter	WRCG185 5/1910-1835/1925-40/8SS	Wainwright	7	300003350	ev		
16	n. a.	Band Reject filter	WRCG240 0/2483-2375/2505-50/10SS	Wainwright	11	300003351	ev		
17	n. a.	TILE-Software Emission	Quantum Change, Modell TILE-ICS/FULL	EMCO	none	300003451	ne		
18	n. a.	Highpass Filter	WHKX2.9/1 8G-12SS	Wainwright	1	300003492	ev		
19	n. a.	Highpass Filter	WHK1.1/15 G-10SS	Wainwright	3	300003255	ev		
20	n. a.	Highpass Filter	WHKX7.0/1 8G-8SS	Wainwright	18	300003789	ne		
21	n. a.	PSA Spectrum Analyzer 3 Hz - 26.5 GHz	E4440A	Agilent Technologies	MY48250080	300003812	k	08.09.2010	08.09.2012
22	n. a.	MXG Microwave Analog Signal Generator	N5183A	Agilent Technologies	MY47420220	300003813	k	13.09.2010	13.09.2012

23	n. a.	RF Filter Section 9kHz - 1GHz	N9039A	Agilent Technologies	MY48260003	300003825	vKI!	08.09.2010	08.09.2012
24	n. a.	TRILOG Broadband Test-Antenna 30 MHz - 3 GHz	VULB9163	Schwarzbeck	371	300003854	vKI!	14.10.2011	14.10.2014
25	45	Switch-Unit	3488A	HP Meßtechnik	2719A14505	300000368	g		
26	50	DC power supply, 60Vdc, 50A, 1200 W	6032A	HP Meßtechnik	2920A04466	300000580	ne		
27	n. a.	software	SPS_PHE 1.4f	Spitzberger & Spieß	B5981; 5D1081; B5979	300000210	ne		
28	n. a.	EMI Test Receiver	ESCI 1166.5950.03	R&S	100083	300003312	k	04.01.2012	04.01.2014
29	n. a.	Analyzer-Reference-System (Harmonics and Flicker)	ARS 16/1	SPS	A3509 07/0 0205	300003314	k	14.07.2011	14.07.2013
30	n. a.	Amplifier	JS42-00502650-28-5A	MITEQ	1084532	300003379	ev		
31	n. a.	Antenna Tower	Model 2175	ETS-LINDGREN	64762	300003745	izw		
32	n. a.	Positioning Controller	Model 2090	ETS-LINDGREN	64672	300003746	izw		
33	n. a.	Turntable Interface-Box	Model 105637	ETS-LINDGREN	44583	300003747	izw		
34	n. a.	TRILOG Broadband Test-Antenna 30 MHz - 3 GHz	VULB9163	Schwarzbeck	295	300003787	k	01.04.2010	01.04.2012
35	n. a.	Spectrum-Analyzer	FSU26	R&S	200809	300003874	k	10.01.2011	10.01.2013

Agenda: Kind of Calibration

k	calibration / calibrated	EK	limited calibration
ne	not required (k, ev, izw, zw not required)	zw	cyclical maintenance (external cyclical maintenance)
ev	periodic self verification	izw	internal cyclical maintenance
Ve	long-term stability recognized	g	blocked for accredited testing
vKI!	Attention: extended calibration interval		
NK!	Attention: not calibrated	*)	next calibration ordered / currently in progress

11 Observations

No observations exceeding those reported with the single test cases have been made.

Annex A Photographs of the test setup

Photo 1:

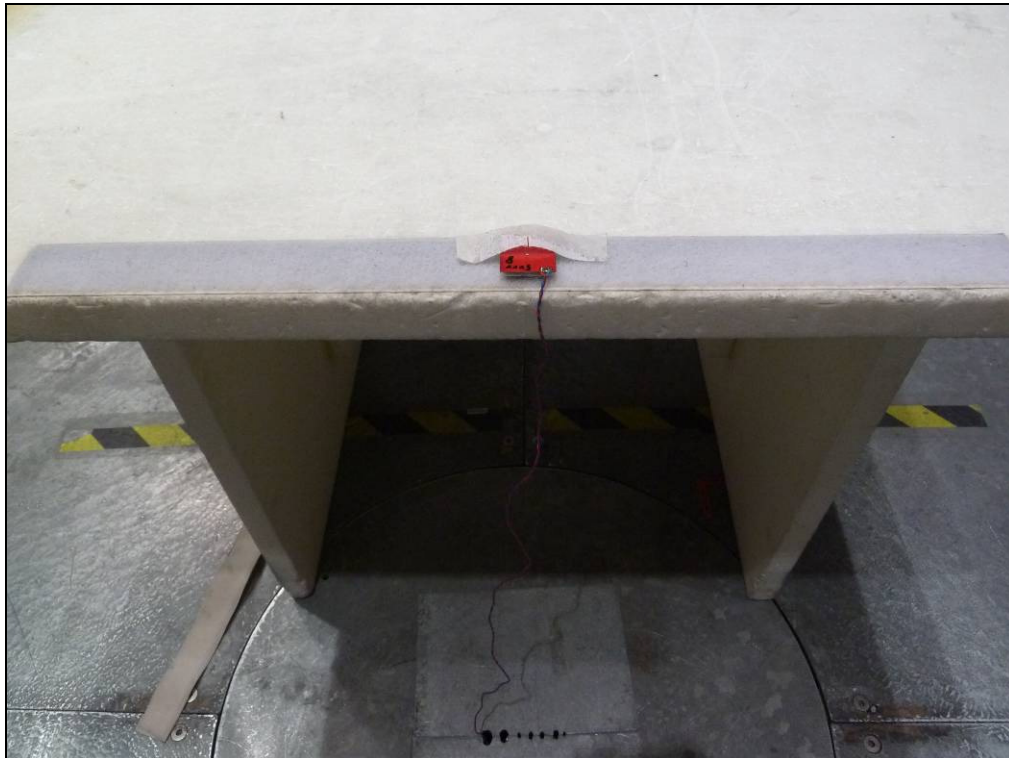

Photo 2:

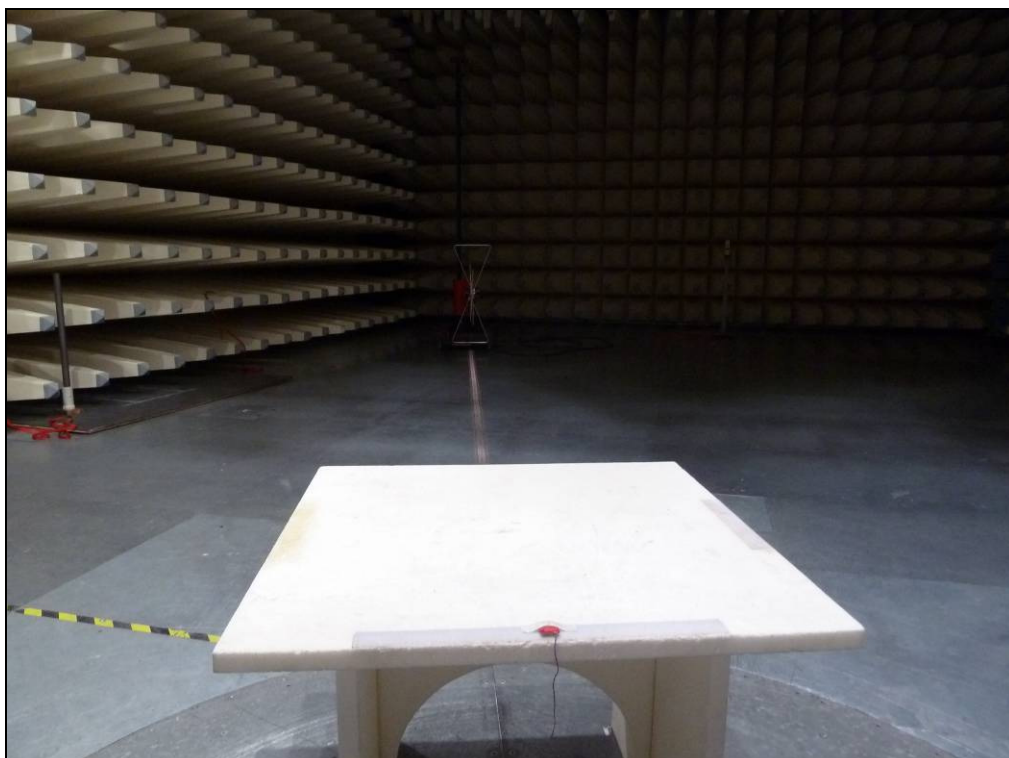

Photo 3:

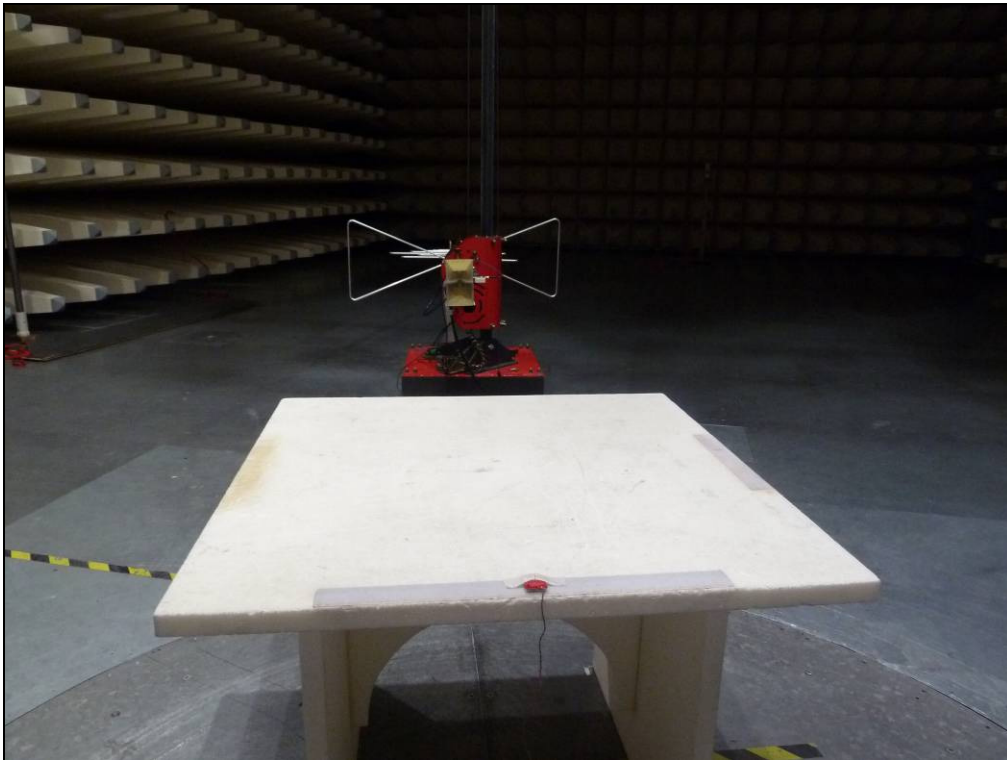

Photo 4:



Annex B External photographs of the EUT

Photo 5:



Photo 6:



Annex C Internal photographs of the EUT

Photo 7:

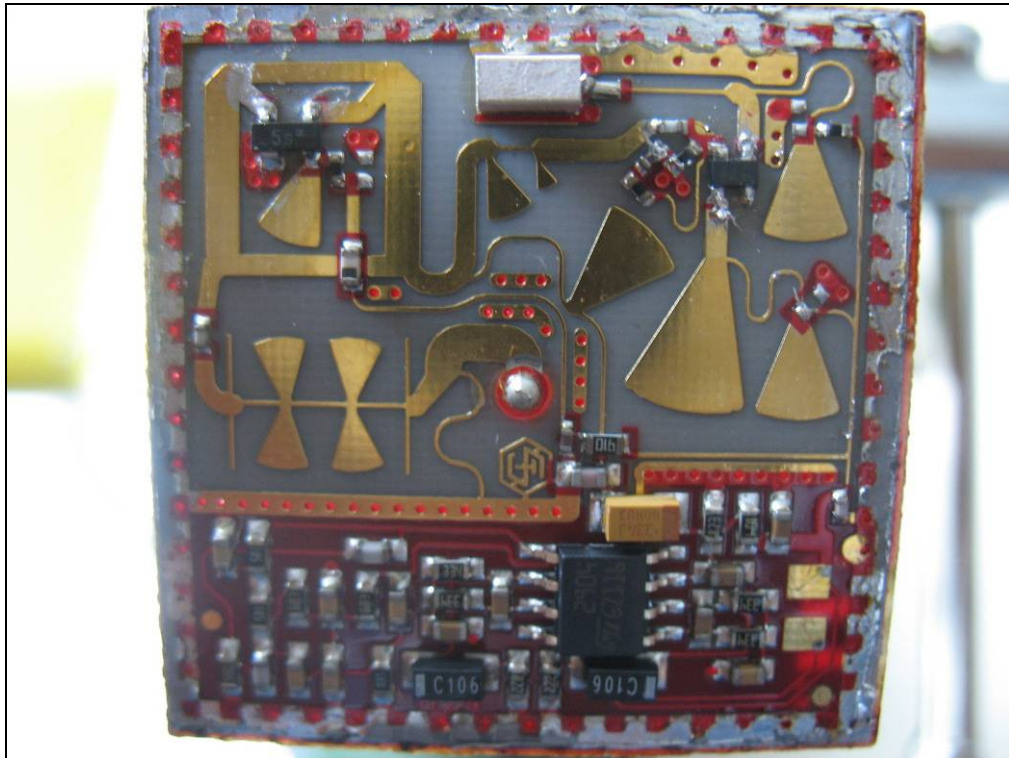

Photo 8:

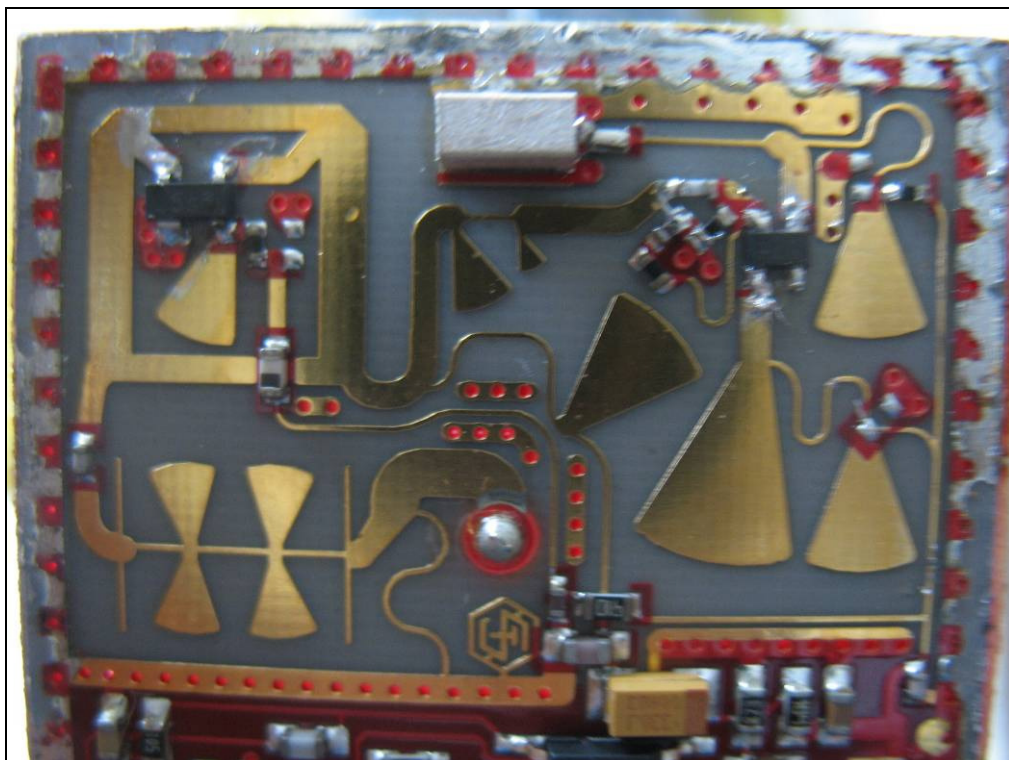
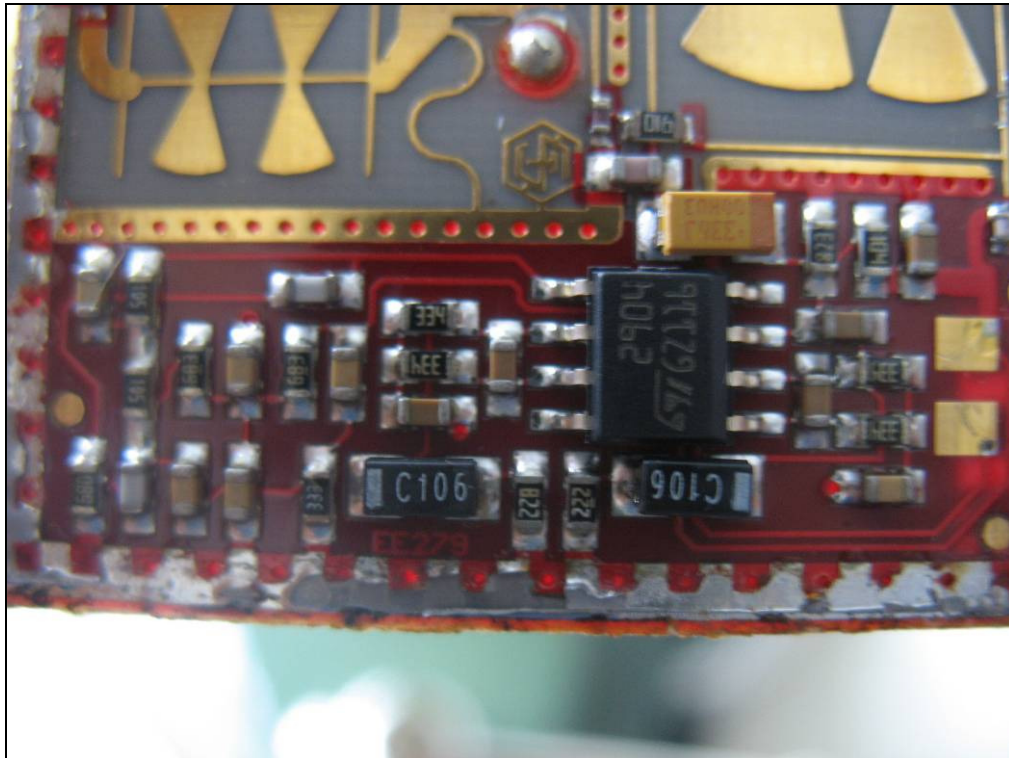

Photo 9:



Annex D Document history

Version	Applied changes	Date of release
1.0	Initial release	2012-04-03
-A	Internal photos added	2012-04-24
-B	Typos	2012-05-04

Annex E Further information**Glossary**

AVG	-	Average
DUT	-	Device under test
EMC	-	Electromagnetic Compatibility
EN	-	European Standard
EUT	-	Equipment under test
ETSI	-	European Telecommunications Standard Institute
FCC	-	Federal Communication Commission
FCC ID	-	Company Identifier at FCC
HW	-	Hardware
IC	-	Industry Canada
Inv. No.	-	Inventory number
N/A	-	Not applicable
PP	-	Positive peak
QP	-	Quasi peak
S/N	-	Serial number
SW	-	Software

Annex F Accreditation Certificate



Front side of certificate



Back side of certificate

Note:
The current certificate including annex is published on our website (see link below) or may be received from CETECOM ICT Services on request.

http://www.cetecom.com/fileadmin/de/CETECOM_D_Saarbruecken/accreditations_Jan_2010/DAKKS_Akkredi_Urk_EN17025-En_incl_Annex.pdf