

---

# FCC Test Report

---

Report No.: AGC087110501-2F2

**FCC ID** : W8DF17

**PRODUCT DESIGNATION** : FM transmitter

**BRAND NAME** : N/A

**TEST MODEL** : F17

**CLIENT** : Shenzhen Onuoda Electronics Technology Co., Ltd

**DATE OF ISSUE** : May 26, 2011

**STANDARD(S)** : FCC Part 15 Rules

Attestation of **Global Compliance Co., Ltd.**

CAUTION: This report shall not be reproduced except in full without the written permission of the test laboratory and shall not be quoted out of context.

**TABLE OF CONTENTS**

- 1. VERIFICATION OF COMPLIANCE.....3**
- 2. GENERAL INFORMATION.....4**
  - 2.1. PRODUCT DESCRIPTION FOR EQUIPMENT UNDER TEST (EUT).....4**
  - 2.2. TEST STANDARDS .....4**
  - 2.3. RELATED SUBMITTAL(S)/GRANT(S).....4**
  - 2.4. TEST METHODOLOGY.....4**
  - 2.5. TEST FACILITY .....5**
  - 2.6. EUT EXERCISE SOFTWARE .....5**
  - 2.7. ACCESSORIES EQUIPMENT LIST AND DETAILS.....5**
  - 2.8. EUT PORT&CABLE LIST AND DETAILS.....5**
- 3. SUMMARY OF TEST RESULTS.....6**
- 4 TEST MODES .....6**
- 5.§15.203 - ANTENNA REQUIREMENT.....7**
  - 5.1. STANDARD APPLICABLE.....7**
  - 5.2. TEST RESULT .....7**
- 6.§15.209, §15.239 (B)(C)- RADIATED EMISSION.....8**
  - 6.1. MEASUREMENT UNCERTAINTY.....8**
  - 6.2. STANDARD APPLICABLE.....8**
  - 6.3. TEST EQUIPMENT LIST AND DETAILS.....8**
  - 6.4. TEST PROCEDURE.....8**
  - 6.5. TEST SET-UP (BLOCK DIAGRAM OF CONFIGURATION).....9**

**6.6. LIMITS AND TEST RESULTS/PLOTS .....11**

**7. §15.239(A) EMISSION BANDWIDTH TESTING .....19**

**7.1. STANDARD APPLICABLE.....19**

**7.2. TEST EQUIPMENT LIST AND DETAILS.....19**

**7.3. TEST PROCEDURE.....19**

**7.4. SUMMARY OF TEST RESULTS/PLOTS.....19**

**8.§15.239(A) FREQUENCY RANGE .....21**

**8.1. STANDARD APPLICABLE.....21**

**8.2. TEST EQUIPMENT LIST AND DETAILS.....21**

**8.3. SUMMARY OF TEST RESULTS/PLOTS.....21**

**APPENDIX 1.....23**

**PHOTOGRAPHS OF TEST SETUP.....23**

**APPENDIX 2.....24**

**PHOTOGRAPHS OF EUT .....24**

**APPENDIX 3.....29**

**FCC ID LABEL&LOCATION.....29**

**1. VERIFICATION OF COMPLIANCE**

Applicant:	Shenzhen Onuoda Electronics Technology Co., Ltd
Applicant Address:	3F D Building jingfu industry zone Airway(west) Gushu village xixiang town Bao'an district Shenzhen city Guangdong China
Manufacturer:	Shenzhen Onuoda Electronics Technology Co., Ltd
Manufacturer Address:	3F D Building jingfu industry zone Airway(west) Gushu village xixiang town Bao'an district Shenzhen city Guangdong China
Product Description:	FM transmitter
Brand Name:	N/A
Model Name:	F17
FCC ID:	W8DF17
Report Number:	AGC087110501-2F2
Date of Test:	May 23 ~ May 25, 2011

**WE HEREBY CERTIFY THAT:**

The above equipment was tested by Attestation of Global Compliance Co., Ltd. for compliance with the requirements set forth in the FCC Rules and Regulations Part 15, the measurement procedure according to ANSI C63.4:2003. This said equipment in the configuration described in this report shows the maximum emission levels emanating from equipment are within the compliance requirements.

The test results of this report relate only to the tested sample identified in this report.

Checked By:

*Mary Liu*

Mary Liu

May 26, 2011

Authorized By

*Randy He*

Randy He

May 26, 2011

## 2. GENERAL INFORMATION

### 2.1. PRODUCT DESCRIPTION FOR EQUIPMENT UNDER TEST (EUT)

EUT Designation:	FM transmitter
Brand Name:	N/A
Model Name:	F17
Rated Voltage:	DC 12V~24V by Vehicle Charger
Frequency Range:	88.1-107.9MHz
Channel Separation:	0.1MHz
Modulation Type:	FM
Type of Antenna:	Integrated Antenna
<b>**Note:</b> For more information refer to the circuit diagram form and the user's manual.	

### 2.2. TEST STANDARDS

The following report of is prepared on behalf of the Attestation of Global Compliance Co., Ltd. in accordance with FCC Part 15, Subpart C, and section 15.239, 15.203 and 15.209 of the Federal Communication Commission rules.

The objective is to determine compliance with FCC Part 15, Subpart C, and section 15.239, 15.203 and 15.209 of the Federal Communication Commission rules.

Maintenance of compliance is the responsibility of the manufacturer. Any modification of the product, which result in lowering the emission/immunity, should be checked to ensure compliance has been maintained.

### 2.3. RELATED SUBMITTAL(S)/GRANT(S)

This submittal(s) (test report) is intended for FCC ID: filing to comply with Section 15.239 of the FCC Part 15, Subpart C Rules.

### 2.4. TEST METHODOLOGY

All measurements contained in this report were conducted with ANSI C63.4-2003, American National Standard for Methods of Measurement of Radio-Noise Emissions from Low-Voltage Electrical and Electronic Equipment in the range of 9 kHz to 40 GHz.

The equipment under test (EUT) was configured to measure its highest possible emission level. The test

modes were adapted accordingly in reference to the Operating Instructions. The EUT was tested in all three orthogonal planes and the worse case was showed.

## 2.5. TEST FACILITY

All measurement facilities used to collect the measurement data are located at

### Attestation of Global Compliance Co., Ltd.

(1&2F, No.2 Building, Huafeng No.1 Technical, Industrial Park, Sanwei, Xixiang, Baoan District, Shenzhen, China)

The test site is constructed and calibrated to meet the FCC requirements in documents ANSI C63.4: 2003.

FCC register No.: 259865

## 2.6. EUT EXERCISE SOFTWARE

The EUT exercise program used during the testing was designed to exercise the system components. The test software is started while the EUT system is on.

## 2.7. ACCESSORIES EQUIPMENT LIST AND DETAILS

Device Type	Manufacturer	Model Name	Serial No.	Data Cable	Power Cable
MP3	SSK	N/A	N/A	N/A	N/A
IPHONE	Apple	A1332	N/A	N/A	N/A

## 2.8. EUT PORT&CABLE LIST AND DETAILS

I/O Port Type	Q'TY	Cable	Tested with
AUX IN	1	N/A	1
USB Port	1	N/A	1
Iphone Input	1	N/A	1

**3. SUMMARY OF TEST RESULTS**

Description of Test	Result
§15.203 Antenna Requirement	Compliant
§15.209 General Requirement	Compliant
§15.239 (a) Emission Bandwidth Testing	Compliant
§15.239 (b) Radiated Emission	Compliant
§15.239 (c) Out of band emission Testing	Compliant

**4 TEST MODES**

No.	Test modes
1	88.1 MHz TX on USB Aux. In
2	98.1 MHz TX on USB Aux. In
3	107.9 MHz TX on USB Aux. In
4	88.1 MHz TX on Direct Audio in
5	98.1 MHz TX on Direct Audio in
6	107.9 MHz TX on Direct Audio in
Above 6 modes have been performed for the top, middle and bottom channel on USB Aux. In and Direct Audio in configuration with maximum emission conditions. The worst mode is mode 2(USB Aux. In). only the worst mode was recorded in the test report.	

## **5. § 15.203 - ANTENNA REQUIREMENT**

### **5.1. STANDARD APPLICABLE**

According to FCC 15.203, An intentional radiator shall be designed to ensure that no antenna other than that furnished by the responsible party shall be used with the device. The use of a permanently attached antenna or of an antenna that uses a unique coupling to the intentional radiator shall be considered sufficient to comply with the provisions of this Section. The manufacturer may design the unit so that a broken antenna can be replaced by the user, but the use of a standard antenna jack or electrical connector is prohibited. This requirement does not apply to carrier current devices or to devices operated under the provisions of Sections 15.211, 15.213, 15.217, 15.219, or 15.221. Further, this requirement does not apply to intentional radiators that must be professionally installed, such as perimeter protection systems and some field disturbance sensors, or to other intentional radiators which, in accordance with Section 15.31(d), must be measured at the installation site. However, the installer shall be responsible for ensuring that the proper antenna is employed so that the limits in this Part are not exceeded.

### **5.2. TEST RESULT**

This product has a permanent antenna, fulfill the requirement of this section.



## 6.§15.209, §15.239 (b)(c)- RADIATED EMISSION

### 6.1. MEASUREMENT UNCERTAINTY

Based on NIS 81, The Treatment of Uncertainty in EMC Measurements, the best estimate of the uncertainty of a radiation emissions measurement is +3.0 dB.

### 6.2. STANDARD APPLICABLE

According to §15.239(b), The field strength of any emissions within the permitted 200 kHz band shall not exceed 250 microvolts/meter at 3 meters. The emission limit in this paragraph is based on measurement instrumentation employing an average detector. The provisions in §15.35 for limiting peak emissions apply.

According to §15.239(c), The field strength of any emissions radiated on any frequency outside of the specified 200 kHz band shall not exceed the general radiated emission limits in §15.209.

### 6.3. TEST EQUIPMENT LIST AND DETAILS

Equipment	Manufacturer	Model	S/N	Cal. Date	Cal. Due
PSA SERIES SPECTRUM ANALYZER	AGILENT	E4440A	US41421290	06/29/2010	06/28/2011
BICONICAL ANTENNA	A.H.	SAS-521-4	128	06/29/2010	06/28/2011
LOOP ANTENNA	R&S	HM525	N/A	06/29/2010	06/28/2011
HORN ANTENNA	EM	EM-AH-10180	N/A	06/29/2010	06/28/2011
AMPLIFIER	EM	EM30180	0607030	06/29/2010	06/28/2011
COAXIAL CABLE	SCHWARZBEC K	AK9513	9513-10	06/29/2010	06/28/2011
POSITIONING CONTROLLER	MF	MF-7802	MF780208147	06/29/2010	06/28/2011

### 6.4. TEST PROCEDURE

The setup of EUT is according with per ANSI C63.4-2003 measurement procedure. The specification used was with the FCC Part 15.239(b) and FCC Part 15.209 Limit.

6.5. TEST SET-UP (BLOCK DIAGRAM OF CONFIGURATION)

BELOW 30MHz:

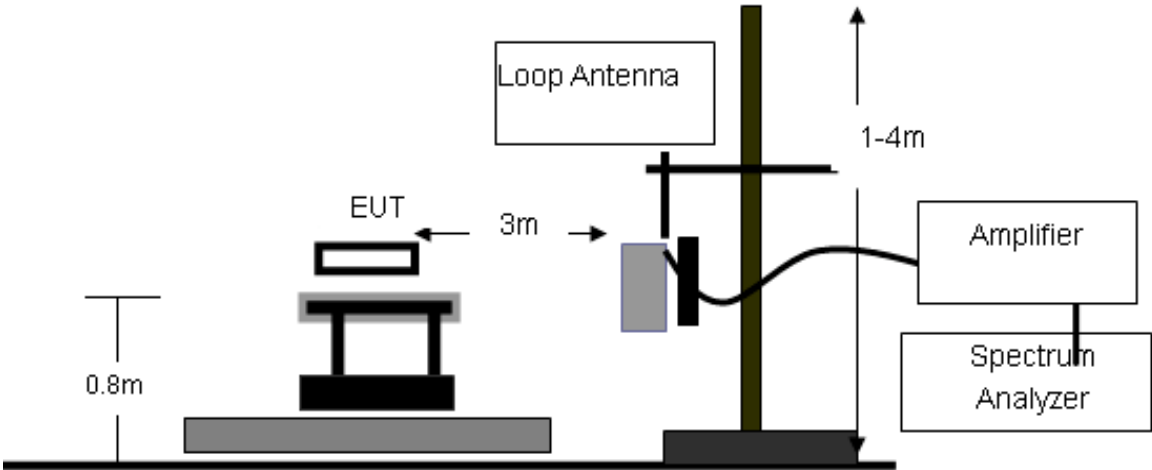

30MHz-1000MHz:

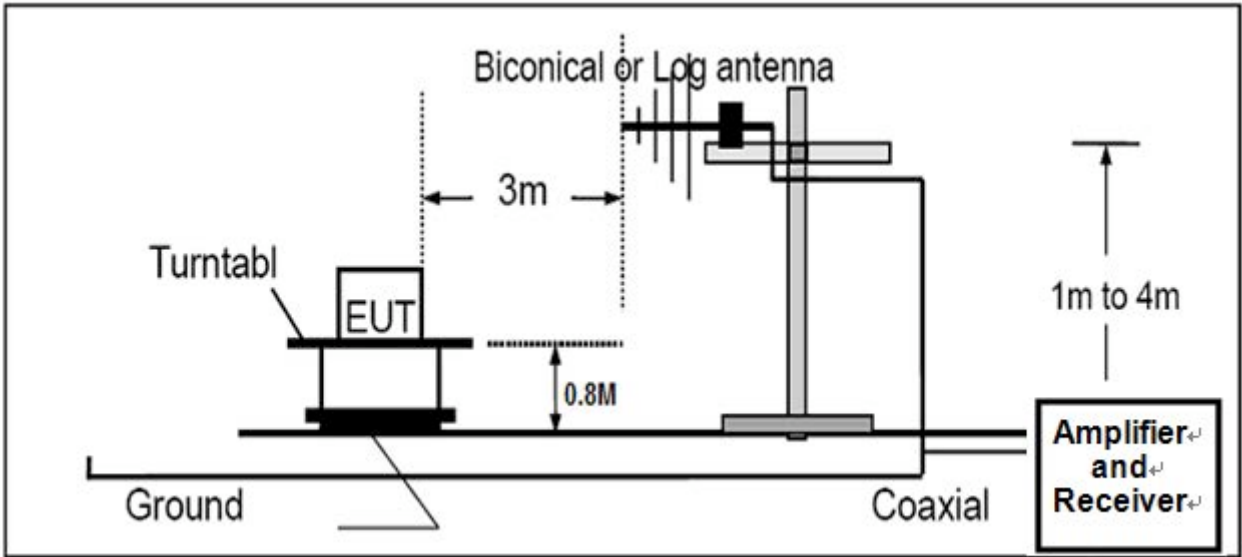

ABOVE 1000MHz:

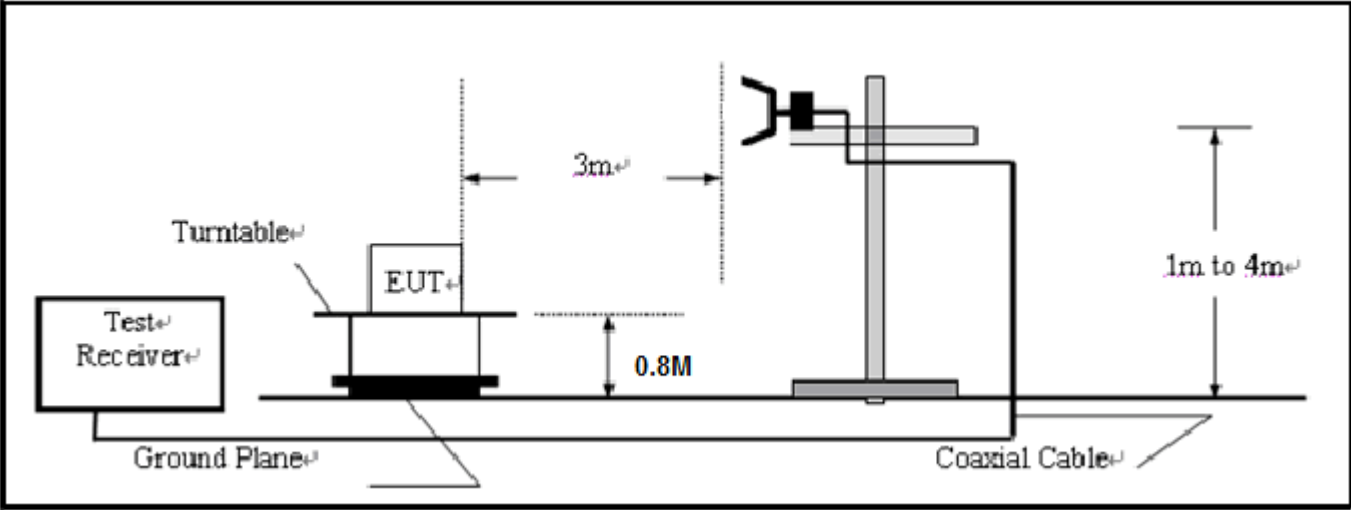

**6.6. LIMITS AND TEST RESULTS/PLOTS**

Operation Mode: FM Transmitter

Test Date: May 23,2011

Temperature: 25°C

Tested by: Mary

Humidity: 55 % RH

RADIATED EMISSION LIMITS:			
Frequency (MHz)	Field Strength		Measurement Distance (meters)
	uV/m	dB uV/m	
0.009 - 0.490	2400/F(kHz)	*	300
0.490 - 1.705	24000/F(kHz)	*	300
1.705 - 30.0	30	29.5	30
30 - 88	100**	40	3
88 - 216	150**	43.5	3
216 - 960	200**	46	3
Above 960	500	54	3
Carrier frequency	250	48(AVG)	3
Carrier frequency		68(Peak)	3

Notes:

\*Emission Level(dB uV/m)=20log Emission Level(uV/m);

\*\*Except as provided in paragraph (g), fundamental emissions from intentional radiators operating under this Section shall not be located in the frequency bands 54-72 MHz, 76-88 MHz, 174-216 MHz or 470-806 MHz. However, operation within these frequency bands is permitted under other sections of this Part, e.g., Sections 15.231 and 15.241.

**TEST RESULT OF RADIATED EMISSION TEST (9KHZ-30MHZ)**

Freq. (MHz)	Level (dB uV)	Over Limit (dB)	Limit Line (dB uV)	Remark
--	--	--	--	Seen to Note

**\*\*Note:**

The amplitude of spurious emissions which are attenuated by more than 20dB below the permissible value has no need to be report.

Distance extrapolation factor=40 log(specific distance/test distance)(dB);

Limit line=specific limits(dBuV)+distance extrapolation factor.

**TEST RESULT OF RADIATED EMISSION TEST (30MHZ-1GHZ)**

Test Result of Bottom Channel (88.1 MHz)

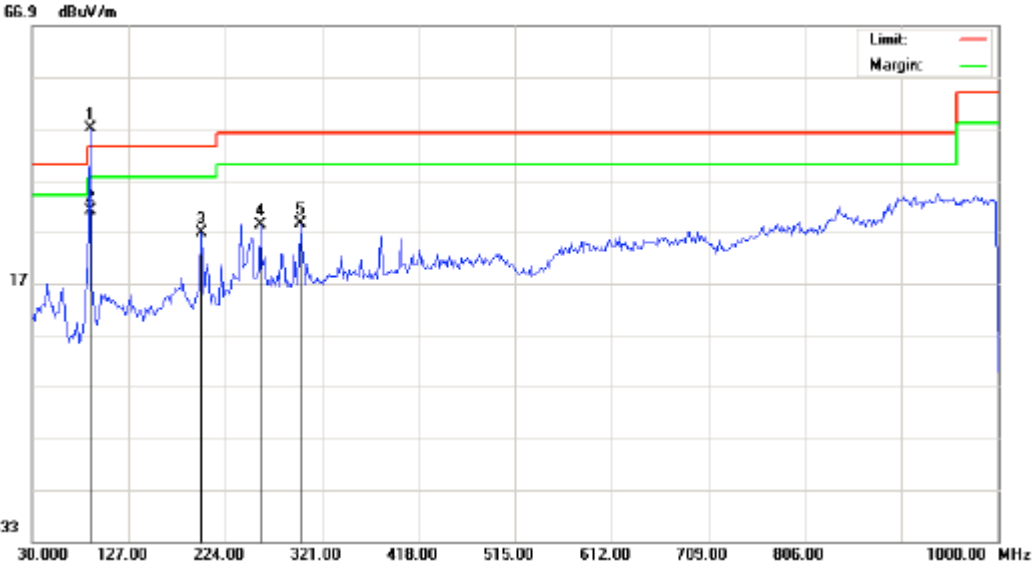

Site: site #1	Polarization: <i>Horizontal</i>	Temperature: 26
Limit: FCC Class B 3M Radiation	Power:	Humidity: 60 %
EUT: FM Transmitter	Distance: 3m	
M/N: F17		
Mode: 88.1MHZ TX		
Note:		

No.	Mk	Freq.	Reading	Factor	Measurement	Limit	Over	Detector	Antenna	Table	Comment
		MHz	dBuV	dB/m	dBuV/m	dBuV/m	dB		Height	Degree	
1	*	88.2000	34.97	11.95	46.92	68.0	-21.08	peak			
2		88.2000	19.06	11.95	31.01	48.00	-16.99	AVG	119	226	
3		199.7500	14.63	12.23	26.66	43.50	-16.64	peak			
4		259.5667	11.54	16.74	28.28	46.00	-17.72	peak			
5		299.9833	11.60	17.00	28.60	46.00	-17.40	peak			

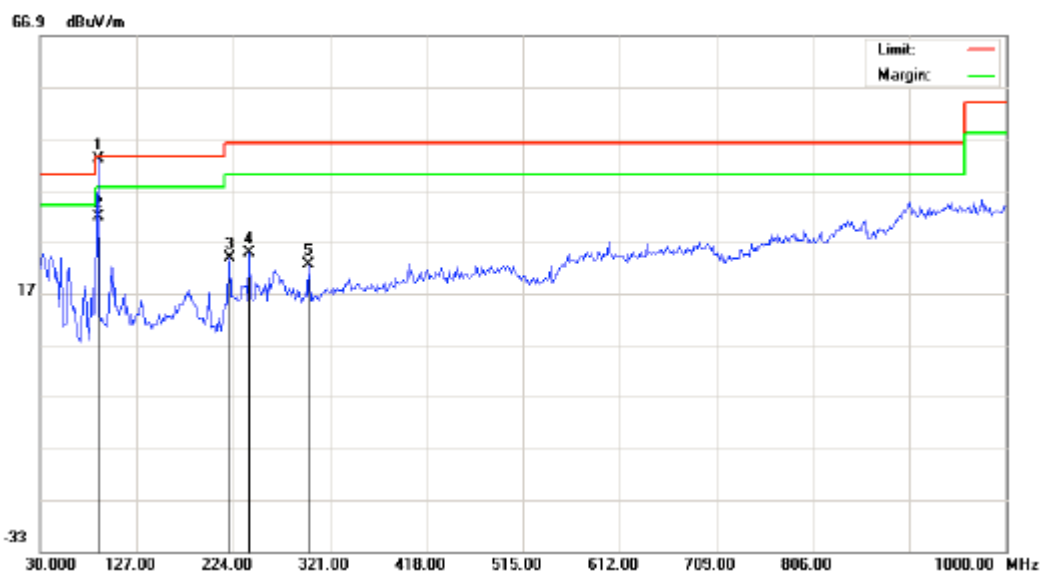



---

Site: site #1    Polarization: *Vertical*    Temperature: 26  
Limit: FCC Class B 3M Radiation    Power:    Humidity: 60 %  
EUT: FM Transmitter    Distance: 3m  
M/N: F17  
Mode: 88.1MHZ TX  
Note:

No.	Mk	Freq.	Reading	Factor	Measurement	Limit	Over	Detector	Antenna Height	Table Degree	Comment
		MHz	dBuV	dBm	dBuV/m	dBuV/m	dB		cm	degree	
1	*	88.2000	31.00	11.95	42.95	88.00	-25.05	peak			
2		88.2000	19.79	11.95	31.74	48.00	-16.28	AVG	100	180	
3		220.7667	9.19	14.55	23.74	46.00	-22.28	peak			
4		240.1667	7.53	17.23	24.76	46.00	-21.24	peak			
5		299.9833	5.55	17.00	22.55	46.00	-23.45	peak			

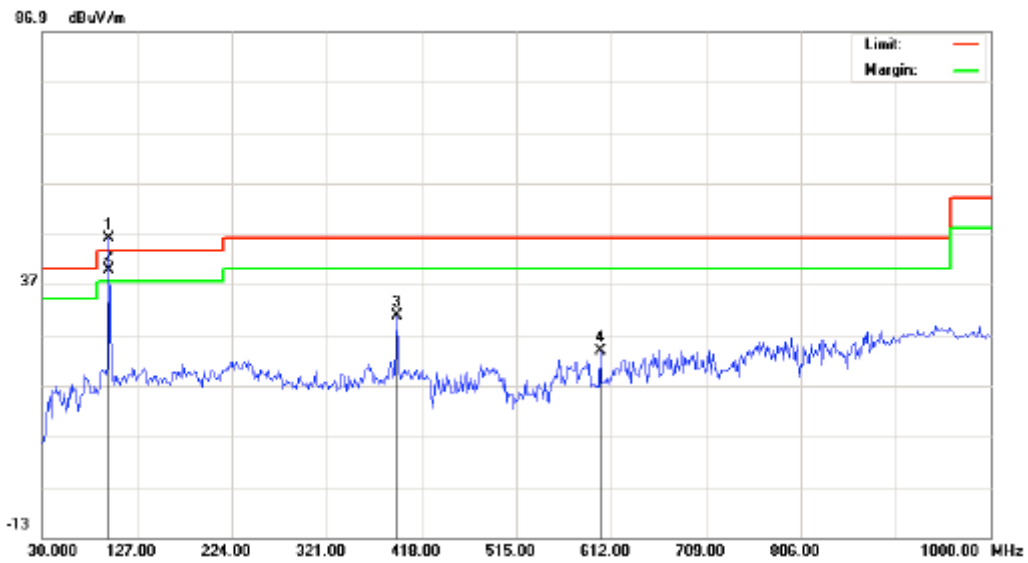
Test Result of Middle Channel (98.1 MHz)



Site: site #1 Polarization: *Horizontal* Temperature: 26  
 Limit: FCC Class B 3M Radiation Power: Humidity: 60 %  
 EUT: FM Transmitter Distance: 3m  
 M/N: F17  
 Mode: 98.1MHZ TX  
 Note:

No.	Mk	Freq.	Reading	Factor	Measurement	Limit	Over	Detector	Antenna Height	Table Degree	Comment
		MHz	dBuV	dB/m	dBuV/m	dBuV/m	dB		cm	degree	
1	*	97.9000	32.04	13.89	45.93	68.0	-22.07	peak			
2		97.9000	25.97	13.89	39.86	48.00	-8.14	AVG		0	
3		392.1333	10.83	20.20	30.83	48.00	-15.17	peak			
4		600.6833	-1.13	24.92	23.79	48.00	-22.21	peak			

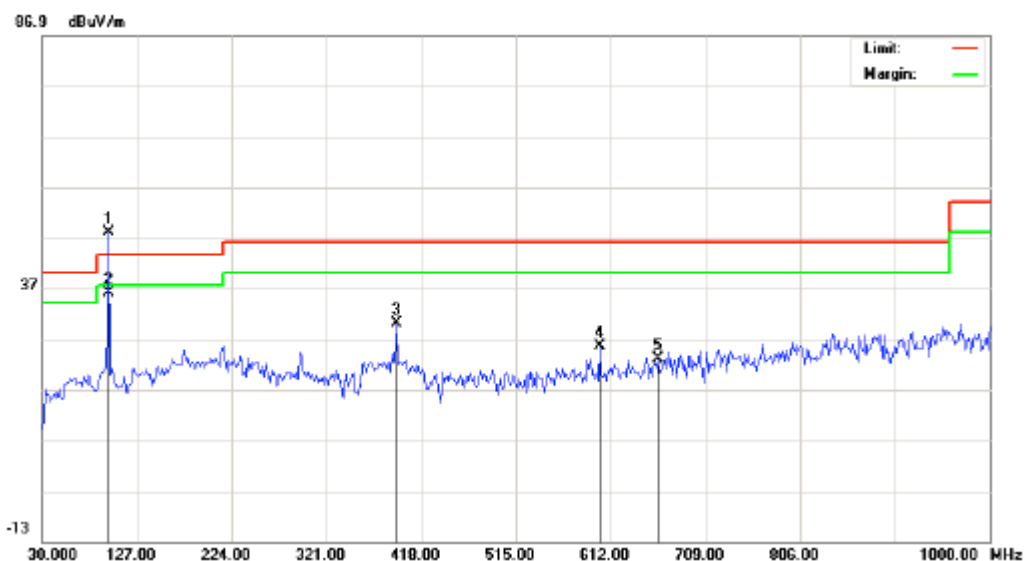

Site: site #1	Polarization: <b>Vertical</b>	Temperature: 26
Limit: FCC Class B 3M Radiation	Power:	Humidity: 60 %
EUT: FM Transmitter	Distance: 3m	
M/N: F17		
Mode: 98.1MHZ TX		
Note:		

No.	Mk	Freq.	Reading	Factor	Measurement	Limit	Over	Detector	Antenna	Table	Comment
		MHz	dBuV	dB/m	dBuV/m	dBuV/m	dB		Height	Degree	
									cm	degree	
1	*	97.9000	37.79	10.15	47.94	68.0	-20.06	peak			
2		97.9000	25.68	10.15	36.03	48.0	-11.97	AVG		0	
3		392.1333	9.73	20.20	29.93	48.00	-18.07	peak			
4		600.6833	0.72	24.92	25.64	48.00	-20.36	peak			
5		660.5000	-2.90	25.82	22.92	48.00	-23.08	peak			



### Test Result of Top Channel (107.9 MHz)

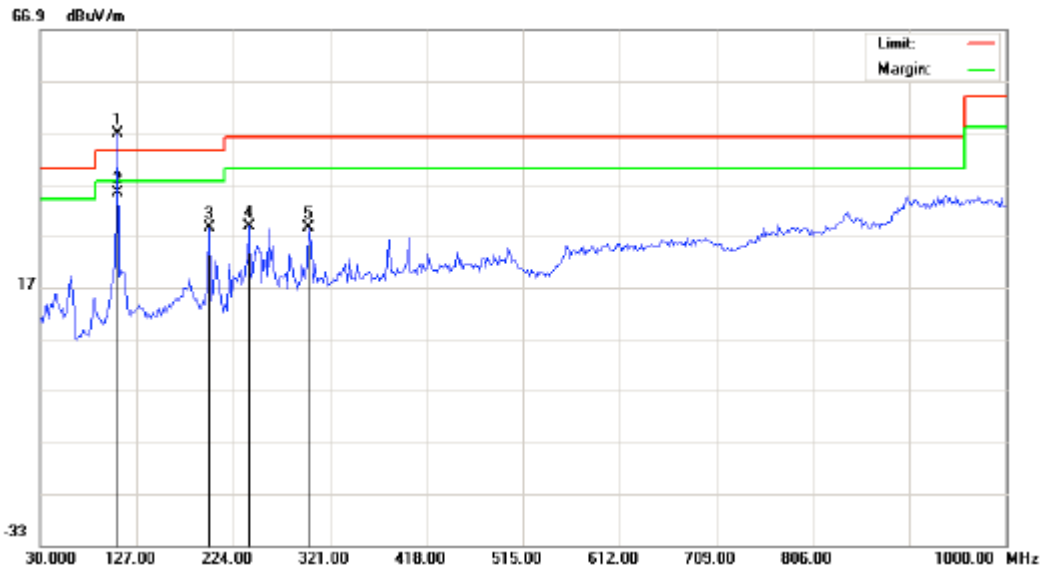

Site: site #1	Polarization: <i>Horizontal</i>	Temperature: 26
Limit: FCC Class B 3M Radiation	Power:	Humidity: 60 %
EUT: FM Transmitter	Distance: 3m	
M/N: F17		
Mode:107.9MHZ TX		
Note:		

No.	Mk	Freq.	Reading	Factor	Measurement	Limit	Over	Detector	Antenna Height	Table Degree	Comment
		MHz	dBuV	dB/m	dBuV/m	dBuV/m	dB		cm	degree	
1	*	107.6000	30.82	16.02	48.84	68.0	-21.16	peak			
2		107.9000	19.27	16.03	35.30	48.0	-12.70	AVG	119	157	
3		199.7500	16.24	12.23	28.47	43.50	-15.03	peak			
4		240.1667	11.65	17.23	28.88	46.00	-17.12	peak			
5		299.9833	11.65	17.00	28.65	46.00	-17.35	peak			

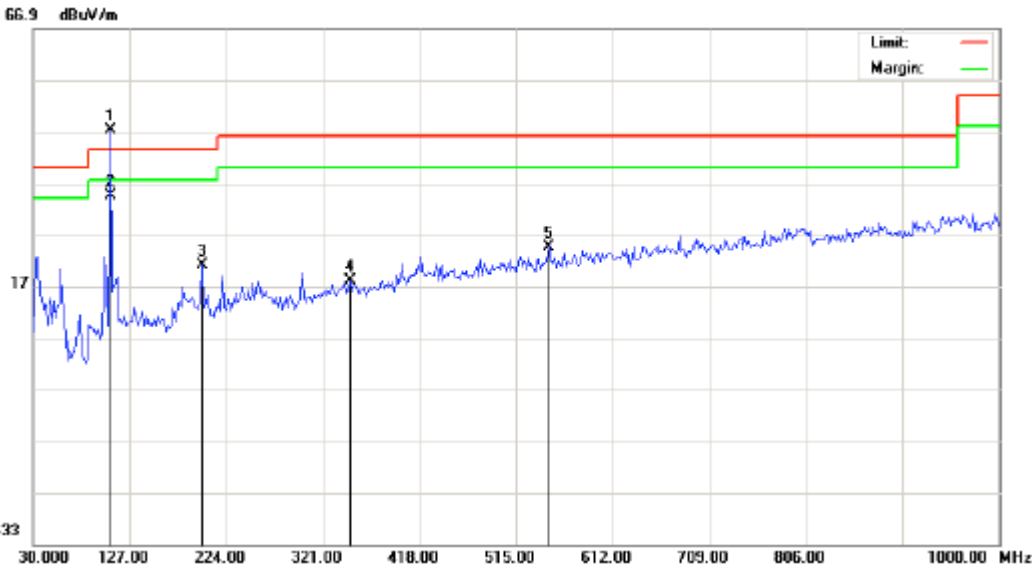

Site: site #1	Polarization: <i>Vertical</i>	Temperature: 26
Limit: FCC Class B 3M Radiation	Power:	Humidity: 60 %
EUT: FM Transmitter	Distance: 3m	
M/N: F17		
Mode:107.9MHZ TX		
Note:		

No.	Mk	Freq.	Reading	Factor	Measurement	Limit	Over	Detector	Antenna	Table	Comment
		MHz	dBuV	dBm	dBuV/m	dBuV/m	dB		Height	Degree	
									cm	degree	
1	*	107.6000	35.95	11.39	47.34	68.00	-20.66	peak			
2		107.9887	23.12	11.43	34.55	48.00	-13.45	AVG	119	157	
3		199.7500	5.76	15.23	20.99	43.50	-22.51	peak			
4		348.4833	-1.11	19.04	17.93	46.00	-28.07	peak			
5		547.3333	0.91	23.65	24.56	46.00	-21.44	peak			

**TEST RESULT OF RADIATED EMISSION TEST (ABOVE 1000MHZ)**

Freq. (MHz)	Level (dB uV)	Over Limit (dB)	Limit Line (dB uV)	Remark
--	--	--	--	Seen to Note

**\*\*Note:**

*The amplitude of spurious emissions which are attenuated by more than 20dB below the permissible value has no need to be report.*

## 7. §15.239(a) EMISSION BANDWIDTH TESTING

### 7.1. STANDARD APPLICABLE

According to FCC 15.239(a), Emissions from the intentional radiator shall be confined within a band 200 kHz wide centered on the operating frequency. The 200 kHz band shall lie wholly within the frequency range of 88–108 MHz.

### 7.2. TEST EQUIPMENT LIST AND DETAILS

Equipment	Manufacturer	Model	S/N	Cal. Date	Cal. Due
PSA SERIES SPECTRUM ANALYZER	AGILENT	E4440A	US41421290	06/29/2010	06/28/2011
RECEIVER ANTENNA	ETS	2175	57337	06/29/2010	06/28/2011
COAXIAL CABLE	ETS	SUCOFLEX 104	25498514	06/29/2010	06/28/2011

### 7.3. TEST PROCEDURE

With the EUT's antenna attached, the EUT's 20dB Bandwidth power was received by the test antenna, which was connected to the spectrum analyzer with the START, and STOP frequencies set to the EUT's operation band.

### 7.4. SUMMARY OF TEST RESULTS/PLOTS

Operation Mode:	FM Transmitter	Test Date:	May 23, 2011
Temperature:	25°C	Tested by:	Mary
Humidity:	55 % RH		

Frequency (MHz)	Emission Bandwidth (KHz)	Limit (KHz)
98.1	53.494	200

**Test Result: Pass**

Middle Channel :

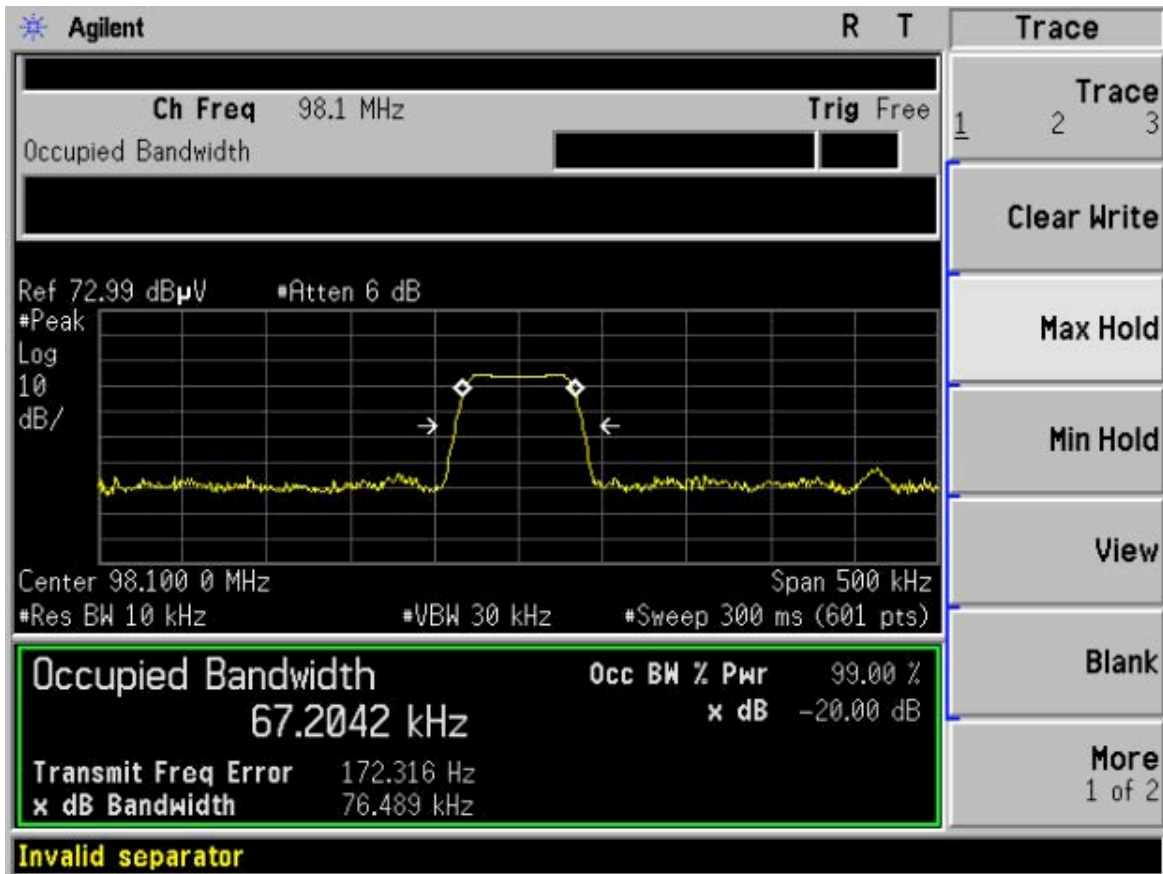

### 8. § 15.239(a) FREQUENCY RANGE

#### 8.1. STANDARD APPLICABLE

(a) Emissions from the intentional radiator shall be confined within a band 200 kHz wide centered on the operating frequency. The 200 kHz band shall lie wholly within the frequency range of 88-108 MHz.

#### 8.2. TEST EQUIPMENT LIST AND DETAILS

Equipment	Manufacturer	Model	S/N	Cal. Date	Cal. Due
PSA SERIES SPECTRUM ANALYZER	AGILENT	E4440A	US41421290	06/29/2010	06/28/2011

#### 8.3. SUMMARY OF TEST RESULTS/PLOTS

Lower Channel:

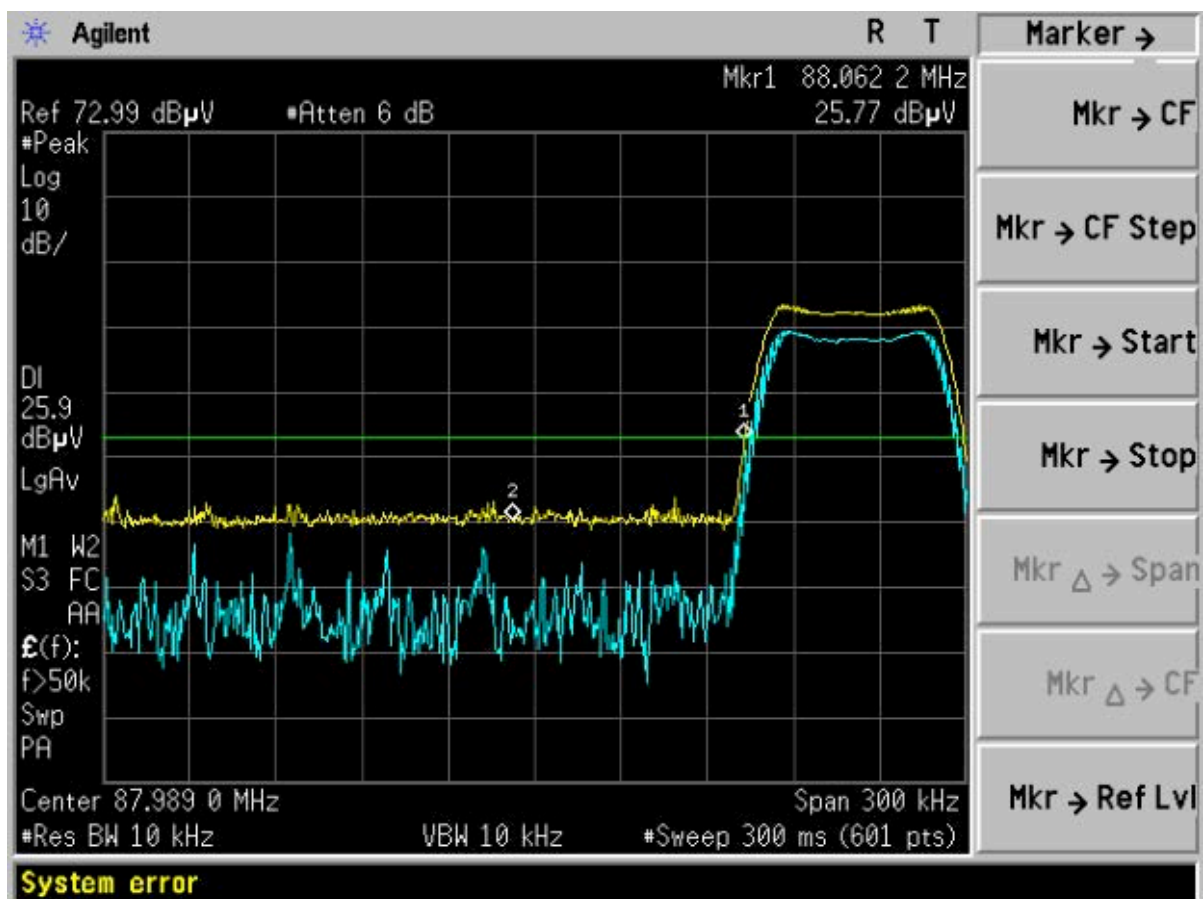

**High Channel:**

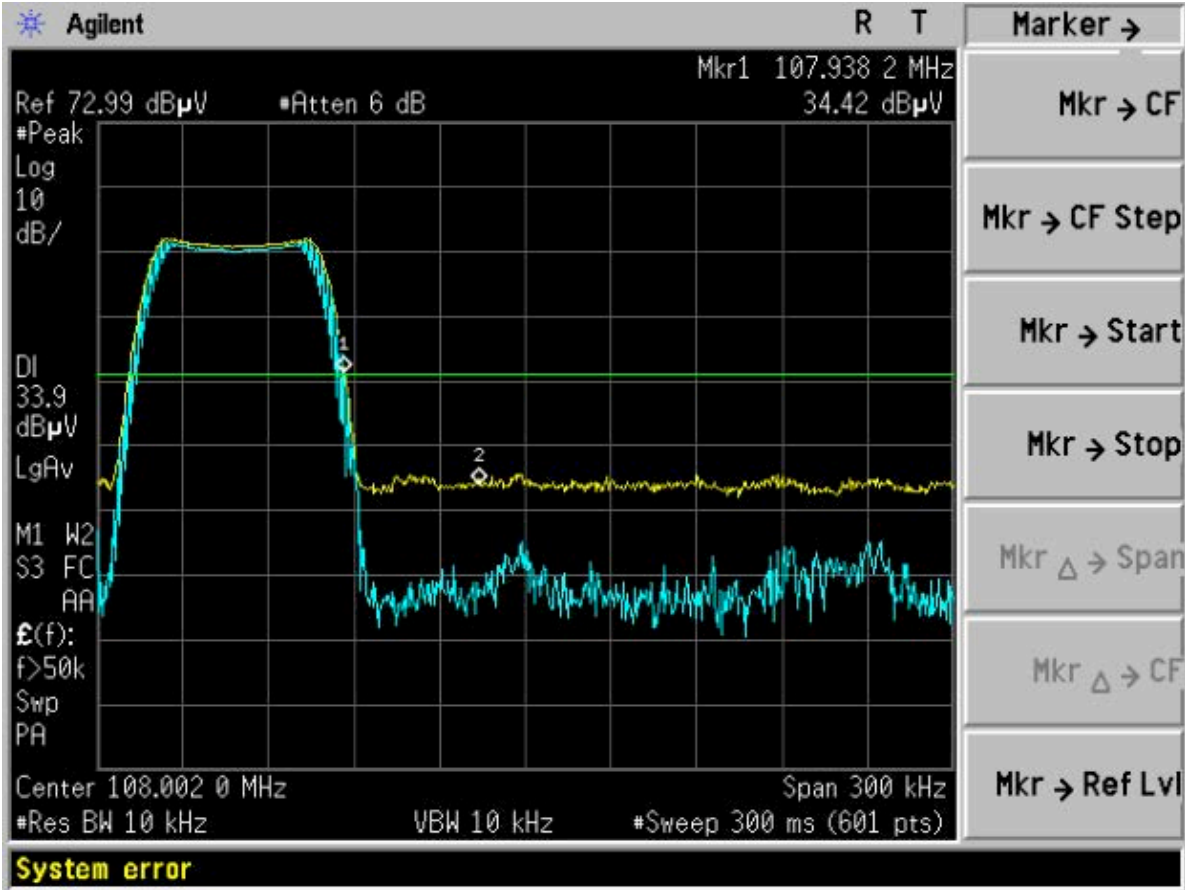

**Tuning Range:**

The device can only be tuned from 88.1 MHz – 107.9 MHz with 0.1 MHz tuning step.

The device works normally after testing.

**APPENDIX 1**  
**PHOTOGRAPHS OF TEST SETUP**  
Radiated Emission Test Setup (Below 30MHz)

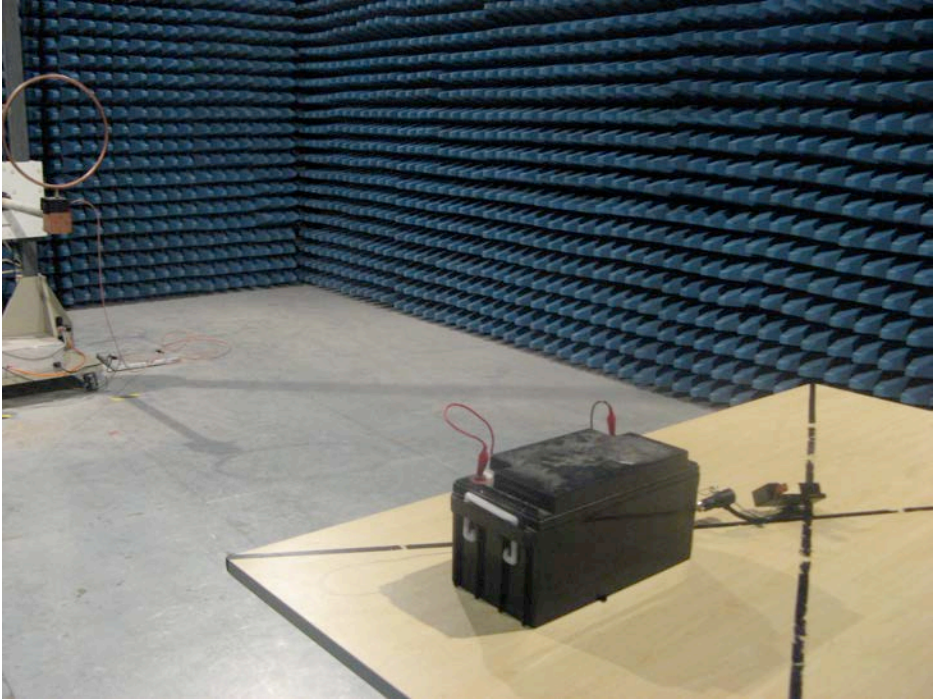

Radiated Emission Test Setup (30MHz-1000MHz)

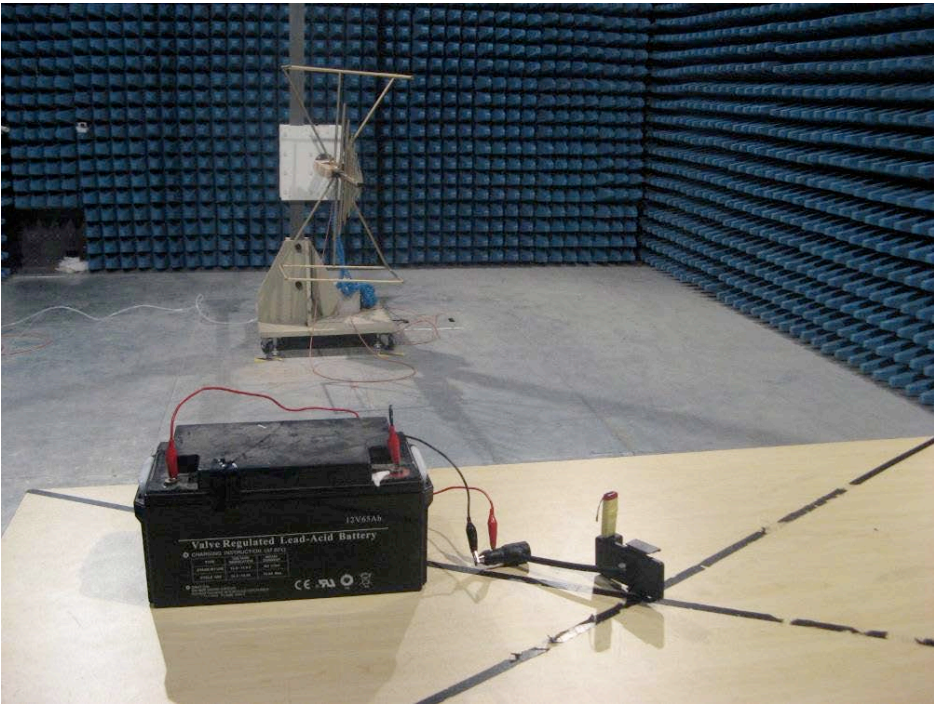



**APPENDIX 2**  
**PHOTOGRAPHS OF EUT**  
TOP VIEW OF EUT



BOTTOM VIEW OF EUT



LEFT VIEW OF EUT



RIGHT VIEW OF EUT



OPEN VIEW OF EUT



VIEW OF PCB-1

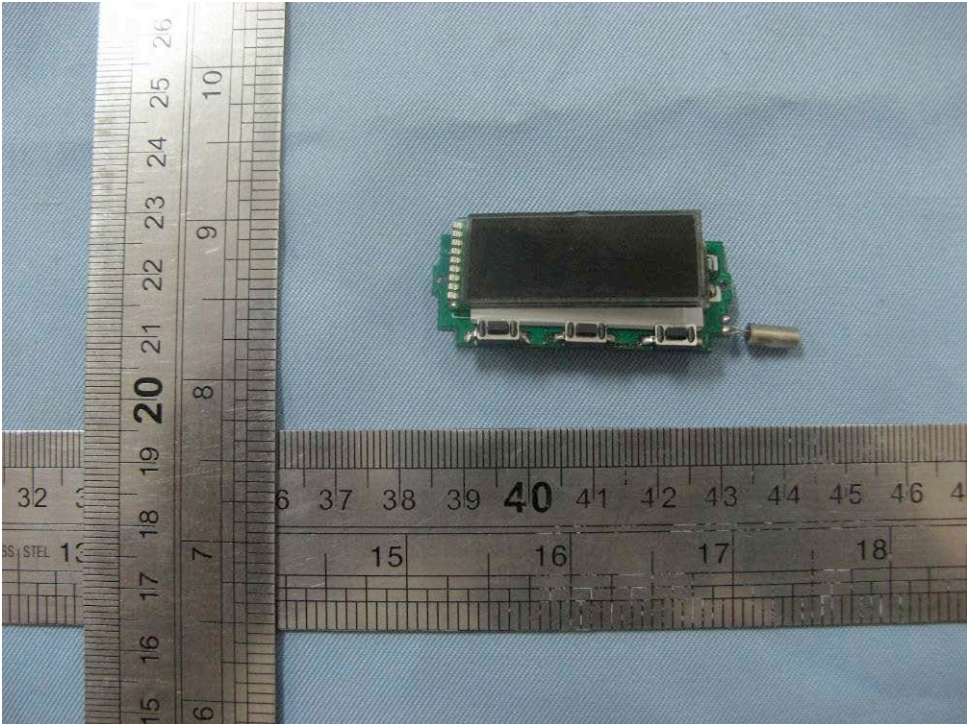

VIEW OF PCB-2

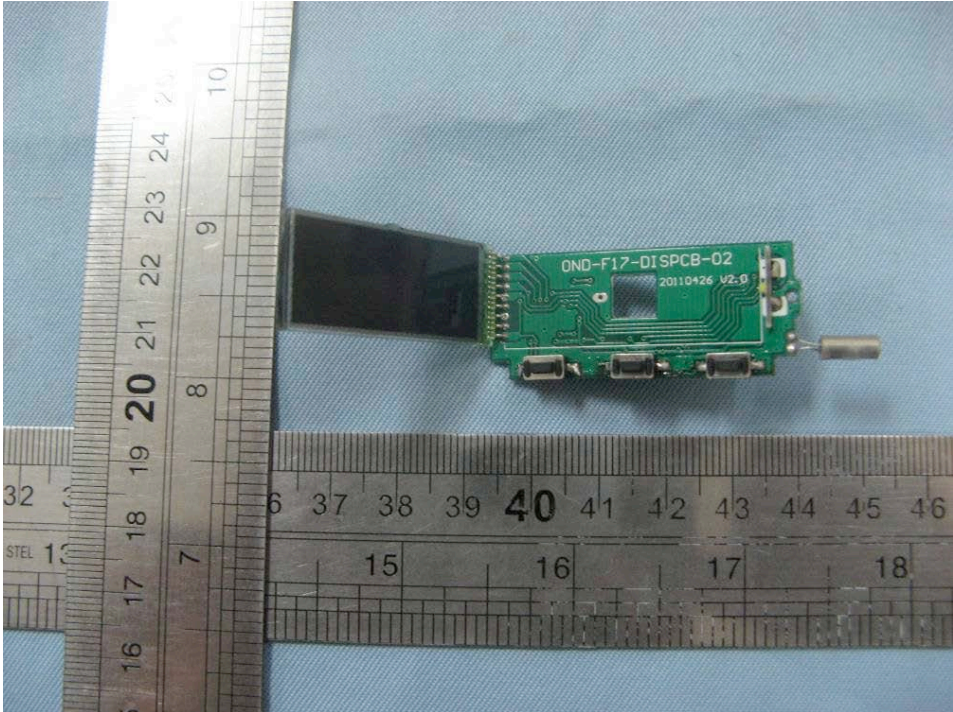

VIEW OF PCB -3

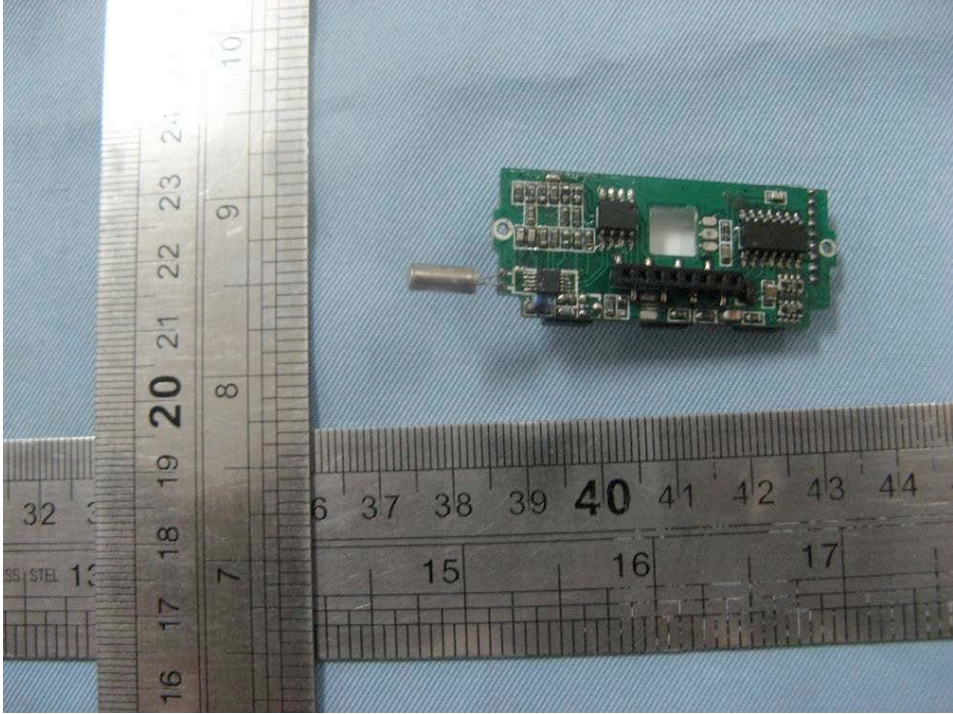

VIEW OF PCB -4

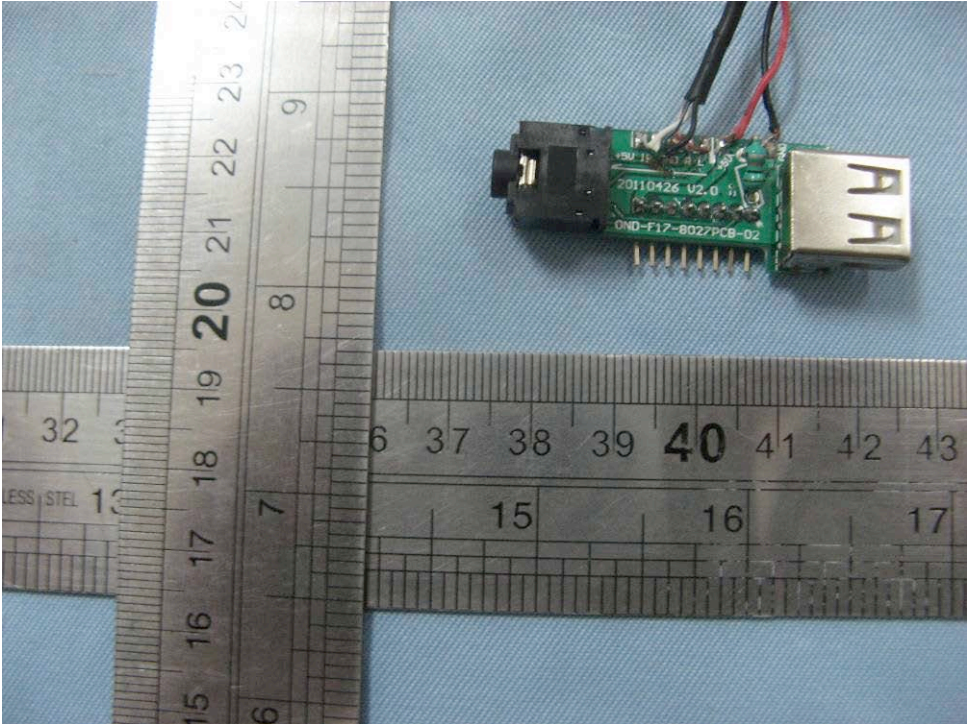

VIEW OF PCB -5

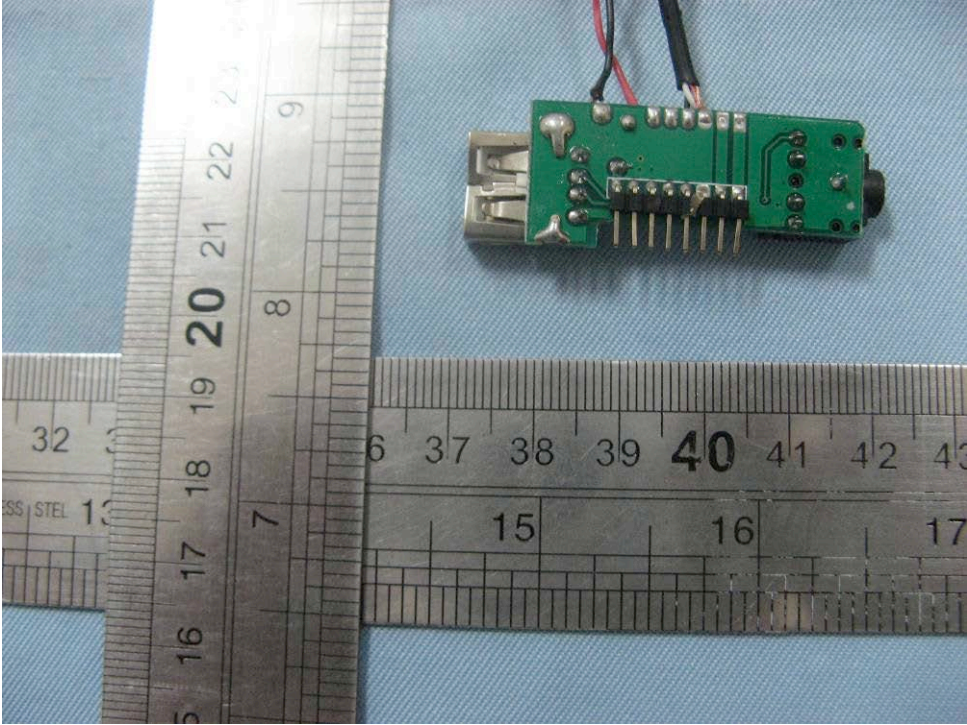

### APPENDIX 3 FCC ID LABEL&LOCATION

Model : F17

Brand: N/A

**FCC ID:W8DF17**

This device complies with Part 15 of the FCC Rules. Operation is subject to the following two conditions: (1) this device may not cause harmful interference, and (2) this device must accept any interference received, including interference that may cause undesired operation.



----- END OF REPORT -----