

FCC TEST REPORT

For

Wireless Environment LLC

NetBright Spotlight

Model No. : MBN340, MBN350

FCC ID : W7DMBN350

Operating Frequency : 433.9MHz

Applicant : Wireless Environment LLC
57 E. Washington Street ,Chagrin Falls,Ohio,United States

Regulation : FCC Part 15 Subpart C Section 15.231

Test Laboratory : Shenzhen CTL Testing Technology Co., Ltd.
Certificated by FCC, Registration No.: 970318

Address : Floor 1-A, Baisha Technology Park, No. 3011, Shahexi Road,
Nanshan Shenzhen Guangdong China

Report NO. : EVRF1412002

Test Date : December 12-16, 2014

Date of Report : December 17, 2014

TABLE OF CONTENT

Description	Page
Test Report Declaration	
1. GENERAL INFORMATION.....	4
1.1 General Information.....	4
1.2 Test Facility.....	4
1.3 Test Summary.....	5
2. TEST INSTRUMENT USED	6
3. RADIATION INTERFERENCE	8
3.1. Radiated Emission Limits(FCC Part 15.209).	8
3.2. Test Procedure.....	9
3.3. Test Setup.....	10
3.4. Test Results.....	11
4. 20DB BANDWIDTH.....	13
4.1. The 20dB Bandwidth of Emission limit according to FCC part 15 Section 15.231(c)....	13
4.2. Test Procedure.....	13
4.3. Test Setup.....	13
4.4. Test Result.....	14
5. TRANSMITTER TIME.....	15
5.1. Transmitter Time Measurement According To FCC Part 15 Section 15.231(a).....	15
5.2. Test Procedure.....	15
5.3. Test Setup.....	15
5.4. Test result	16
6. AVERAGE FACTOR MEASUREMENT	17
6.1. Average Factor Measurement According to ANSI C63.4:2009.....	17
6.2. Test Procedure.....	17
6.3. Test Setup.....	18
6.4. Test Result.....	18
7. ANTENNA REQUIREMENT	20
8. PHOTOGRAPH OF TEST	21

TEST REPORT DECLARATION

Applicant : Wireless Environment LLC
Manufacturer : Bestek Electronics Co., Ltd
EUT Description : NetBright Spotlight
(1)Mode NO.: MBN340, MBN350
(2)Trade Name: Mr Beams
(3)Power supply: DC 4.5V

Test Procedure Used:

FCC Rules and Regulations Part 15 Subpart C Section 15.231
ANSI C63.4-2009

The device described above is test by Shenzhen CTL Testing Technology Co., Ltd. To Determine the maximum emission levels emanating from the device. The maximum emission Levels are compared to FCC part 15 Subpart C Section 15.231. The measurement results Are contained in this test report and Shenzhen CTL Testing Technology Co., Ltd. Is assumed full responsibility for the accuracy and completeness of these measurements, Also, this report shows that the Equipment Under Test (EUT) is to be technically compliant with the FCC requirements.

This report applies to above tested sample only. This report shall not be reproduced in part Without written approval of Shenzhen CTL Testing Technology Co., Ltd

Date of Test:

December 12-16, 2014

Prepared by:



Project Engineer

Reviewer :



Project Manager

1. GENERAL INFORMATION

1.1 General Information

EUT Description	:	NetBright Spotlight
Model No.	:	MBN340, MBN350 Model MBN340 and MBN350 are identical, except the shell color. The model MBN340 is white; The model MBN350 is
Differences	:	black.
Type of Antenna	:	Permanent attached
Antenna Gain	:	0dBi
Modulation	:	ASK
Operation	:	
Frequency	:	433.9MHz
Applicant	:	Wireless Environment LLC 57 E. Washington Street ,Chagrin Falls,Ohio,United States
Manufacturer	:	Bestek Electronics Co., Ltd Building 21, 3 rd Industrial Zone, Xueyuan Road, Longxi, Longgang, Shenzhen, China

1.2 Test Facility

Test Firm	:	Shenzhen CTL Testing Technology Co., Ltd. Certificated by FCC, Registration No.: 970318
Address	:	Floor 1-A, Baisha Technology Park, No. 3011, Shahexi Road, Nanshan Shenzhen Guangdong China
Tel	:	(86)755-89486194
Fax	:	(86)755-26636041

1.3 Test Summary

For the EUT described above. The standards used were FCC Part 15 Subpart C Section 15.231 for Emissions

Tests Carried Out Under FCC Part 15 Subpart C

Standard	Test Items	Status
Section 15.207	Conducted Emission	N/A
Section 15.231(e)	Radiated Emission	Complied
Section 15.231(c)	20dB Bandwidth	Complied
Section 15.231(e)	Release Time Measurement	Complied
Section 15.203	ANTENNA REQUIREMENT	Complied

Temperature : 22 °C
Relative Humidity : 53%
Pressure : 1010hPa
Test Power : DC 4.5V

2. TEST INSTRUMENT USED

	Equipment	Manufacturer	Model No.	S/N	Cal. Date	Next Cal. Date
1	ESD TESTER	HAEFELY	PESD1610	H401552	2013.12.16	2014.12.16
2	MAGNETIC FIELD TESTER	HAEFELY	MAG100	150577	2013.12.16	2014.12.16
3	5kVA AC POWER SOURCE	CALIFORNIA INSTRUMENTS	5001ix-400	55692	2013.12.16	2014.12.16
4	HARMONICS/FLICKER TEST ANALYZER	CALIFORNIA INSTRUMENTS	PACS-1	72254	2013.12.16	2014.12.16
5	50Ω COAXIAL SWITCH	ANRITSU	MP59B	6200283933	2013.12.16	2014.12.16
6	CONICAL HOUSING	ATC	N/A	N/A	N/A	N/A
7	VOLTAGE PROBE	SCHWARZBECK	TK9416	N/A	2013.12.16	2014.12.16
8	RF CURRENT PROBE	ROHDE& SCHWARZ	EZ-17	100048	2013.12.16	2014.12.16
9	BILOG ANTENNA	SCHWARZBECK	VULB9163	194	2013.12.16	2014.12.16
10	SPECTRUM ANALYZER	ANRITSU	MS2651B	N/A	2013.12.16	2014.12.16
11	PRE-AMPLIFIER	AGILENT	8447D	294A10619	2013.12.16	2014.12.16
12	RF COAXIAL CABLE(844 CHAMBER)	SCHWARZBECK	N-5m	NO.1	2013.12.16	2014.12.16
13	THERMO-HYGROMETER	OREGON SCIENTIFIC	JB913R	GZ-WS004	2013.12.16	2014.12.16
14	1# SHIELDING ROOM	CHANGZHOU ZHONGYU	843	N/A	N/A	N/A
15	2# SHIELDING ROOM	CHANGZHOU ZHONGYU	843	N/A	N/A	N/A
16	3m Semi-ANECHOIC CHAMBER	CHANGZHOU ZHONGYU	844	N/A	N/A	N/A
17	ANTENNA/TURNTABLE CONTROLLER	INNCO	CO2000	CO2000/077/7301203/L	N/A	N/A
18	101 LCR METER	YANGZHI	YD2810B	20101170	2013.12.16	2014.12.16
19	RF COAXIAL CABLE(844 CHAMBER)	NTGS8017	N-1m	NO.6	2013.12.16	2014.12.16
20	RF COAXIAL CABLE(844 CHAMBER)	NTGS8017	N-1m	NO.7	2013.12.16	2014.12.16
21	AUDIO GENERATOR	GW	GAG-809	EG835424	N/A	N/A
22	THERMO-HYGROMETER	OREGON SCIENTIFIC	JB913R	GZ-WS002	2013.12.16	2014.12.16

No.	Equipment 29	Manufacturer	Model No.	S/N	Cal. Date	Next Cal. Date
23	EMC PRO SYSTEM (IMMUNITY TESTER)	THERMO	PRO-BASE	0403271	2013.12.16	2014.12.16
24	CAPACITIVE CLAMP (EFT)	THERMO	PRO-CCL	0403272	2013.12.16	2014.12.16
25	COUPLER DECOUPLER FOR TELECOM LINES	THERMO	CM-TEL-CD	0403273	2013.12.16	2014.12.16
26	L.I.S.N.	ROHDE & SCHWARZ	ESH3-Z5	100305	2013.12.16	2014.12.16
27	EMI TEST RECEIVER	ROHDE & SCHWARZ	ESPI-3	100396/003	2013.12.16	2014.12.16
28	SIGNAL GENERATOR	ROHDE & SCHWARZ	SML01	101161	2013.12.16	2014.12.16
29	EMI TEST RECEIVER	ROHDE & SCHWARZ	ESPI-3	101526/003	2013.12.16	2014.12.16
30	SPECTRUM ANALYZER	AGILENT	E7405A	MY45115511	2013.12.16	2014.12.16
31	L.I.S.N.	SCHWARZBECK	NSLK8126	8126431	2013.12.16	2014.12.16
32	PULSE LIMITER (FOR ESPI3)	ROHDE & SCHWARZ	ESH3-Z2	100815	2013.12.16	2014.12.16
33	PRE-AMPLIFIER	ROHDE & SCHWARZ	CBLU1183540-0 1	3791	2013.12.16	2014.12.16
34	50Ω COAXIAL SWITCH	ANRITSU	MP59B	6200506474	2013.12.16	2014.12.16
35	BILOG ANTENNA	SCHWARZBECK	VULB9163	9163-323	2013.12.16	2014.12.16
36	HORN ANTENNA	SCHWARZBECK	BBHA9120D	9120D-655	2013.12.16	2014.12.16
37	HORN ANTENNA	SCHWARZBECK	BBHA9170	9170-359	N/A	N/A
38	LOOP ANTENNA	SCHWARZBECK	FMZB1516	1516131	2013.12.16	2014.12.16
39	ULTRA COMPACT SIMULATOR	EM TEST	UCS 500 N5	V0928104968	2013.12.16	2014.12.16
40	CAPACITIVE CLAMP	EM TEST	HFK	0509-34	2013.12.16	2014.12.16
41	Transformer	EM TEST	V4780S2	0109-44	N/A	N/A
42	Conducted Immunity Test System	FRANKONIA	CIT-10	126B1121	2013.12.16	2014.12.16
43	CDN	FRANKONIA	CDN-M2/3	A3027020	2013.12.16	2014.12.16
44	EM Injection Clamp	FCC	F-203I-23mm	091824	2013.12.16	2014.12.16
45	LISN	AFJ	LS16C	16010946249	2013.12.16	2014.12.16
46	CLICK METER	AFJ	CL55C	55040947164	2013.12.16	2014.12.16

3. RADIATION INTERFERENCE

3.1. Radiated Emission Limits(FCC Part 15.209).

Frequency (MHz)	Field strength (microvolts/meter)	Measurement distance (meters)
0.009-0.490	2400/F(kHz)	300
0.490-1.705	24000/F(kHz)	30
1.705-30.0	30	30
30-88	100**	3
88-216	150**	3
216-960	200**	3
Above 960	500	3

Note: (1) The tighter limit applies at the band edges.
 (2) Emission level (dBuV/m)=20log Emission level (uV/m).

Limits Of Radiated Emission Measurement (FCC Part 15.231)

Fundamental frequency (MHz)	Field strength of fundamental (microvolts/meter)	Field strength of spurious emissions (microvolts/meter)
40.66-40.70	2,250	225
70-130	1,250	125
130-174	11,250 to 3,750	1125 to 375
174-260	3,750	375
260-470	13,750 to 12,500	1375 to 1,250
Above 470	12,500	1,250

Notes:

(1) ** linear interpolations

[Where F is the frequency in MHz, the formulas for calculating the maximum permitted fundamental field strengths are as follows: for the band 130-174 MHz, uV/m at 3 meters = 56.81818(F) - 6136.3636; for the band 260-470 MHz, uV/m at 3 meters = 41.6667(F) - 7083.3333. The maximum permitted unwanted emission level is 20 dB below the maximum permitted fundamental level.]

The limits on the field strength of the spurious emissions in the above table are based on the fundamental frequency of the intentional radiator. Spurious emissions shall be attenuated to the average (or, alternatively, CISPR quasi-peak) limits shown in this table or to the general limits shown in 93 Section 15.209, whichever limit permits a higher field strength.

3.2. Test Procedure

- a. The measuring distance of at 3 m shall be used for measurements at frequency up to 1GHz. For frequencies above 1GHz, any suitable measuring distance may be used.
- b. The EUT was placed on the top of a rotating table 0.8 meters above the ground at a 3m meter open area test site. The table was rotated 360 degrees to determine the position of the highest radiation.
- c. The height of the equipment or of the substitution antenna shall be 0.8 m; the height of the test antenna shall vary between 1 m to 4 m.
- d. The initial step in collecting conducted emission data is a spectrum analyzer peak detector mode pre-scanning the measurement frequency range. Significant peaks are then marked and then Quasi Peak detector mode re-measured.
- e. If the Peak Mode measured value compliance with and lower than Quasi Peak Mode Limit, the EUT shall be deemed to meet QP Limits and then no additional QP Mode measurement performed.
- f. For the actual test configuration, please refer to the related Item –EUT Test Photos

Receiver Parameter	Setting
Attenuation	Auto
Start ~ Stop Frequency	9kHz~150kHz / RB 200Hz for QP
Start ~ Stop Frequency	150kHz~30MHz / RB 9kHz for QP
Start ~ Stop Frequency	30MHz~1000MHz / RB 120kHz for QP

Spectrum Parameter	Setting
Attenuation	Auto
Start Frequency	1000 MHz
Stop Frequency	10th carrier harmonic
RB / VB (emission in restricted band)	1MHz / 1MHz for Peak

Note:

Both horizontal and vertical antenna polarities were tested and performed pretest to three orthogonal axis. The worst case emissions were reported

3.3. Test Setup

(1) Radiated Emission Test-Up Frequency Below 30MHz

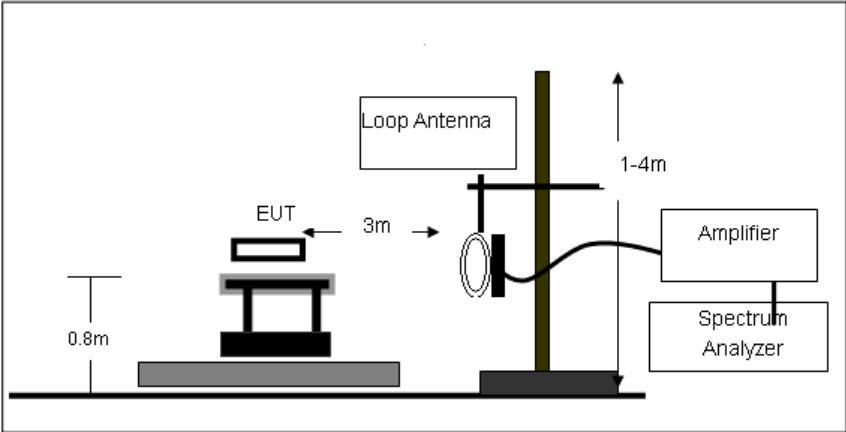

(2) Radiated Emission Test-Up Frequency 30MHz~1GHz

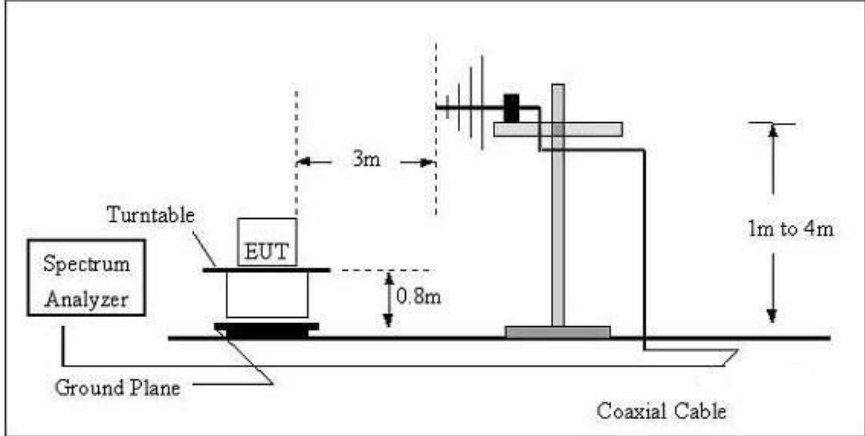

(3) Radiated Emission Test-Up Frequency Above 1GHz

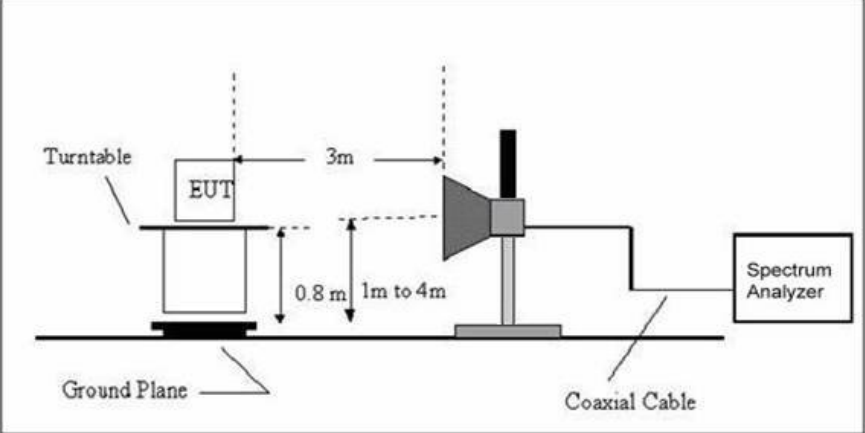

3.4. Test Results

BELOW 30MHz

Freq.(MHz)	Reading(dBuV/m) (QP)	Limit(dBuV/m)	Margin(dB)	Results
/	/	/	/	Pass
/	/	/	/	Pass
/	/	/	/	Pass

Note:

The amplitude of spurious emissions which are attenuated by more than 20dB below the permissible value has no need to be reported.

Distance extrapolation factor = $40 \log(\text{specific distance/test distance})$ (dB);

Limit line = specific limits(dBuV) + distance extrapolation factor.

(BETWEEN 30 – 5000 MHZ)

Frequency (MHz)	Reading (dB μ V/m)	Factor Corr.	Average Factor	Result(dB μ V/m)		Limit(dB μ V/m)		Margin(dB)		Polarization
	PEAK	(dB)	(dB)	AV	PEAK	AV	PEAK	AV	PEAK	
433.90	76.69	-15.06	-7.92	53.71	61.63	80.8	100.8	-27.09	-14.13	Horizontal
867.84	49.36	-6.64	-7.92	34.80	42.72	60.8	80.8	-26.00	-38.08	
1301.76	60.86	-10.14	-7.92	42.80	50.72	60.8	80.8	-18.00	-30.08	
1735.68	58.56	-8.80	-7.92	41.54	49.46	60.8	80.8	-19.26	-31.34	
2169.60	52.97	-7.35	-7.92	37.70	45.62	60.8	80.8	-23.10	-35.18	
433.90	76.06	-15.06	-7.92	53.08	61.00	80.8	100.8	-27.72	-39.80	Vertical
867.84	49.97	-6.64	-7.92	35.41	43.33	60.8	80.8	-25.39	-37.47	
1301.76	61.78	-10.14	-7.92	43.72	51.64	60.8	80.8	-17.08	-29.16	
1735.68	58.96	-8.80	-7.92	42.24	50.16	60.8	80.8	-18.56	-30.64	
2169.60	56.77	-7.35	-7.92	41.50	49.42	60.8	80.8	-19.30	-31.38	

Note:

1, Emissions attenuated more than 20dB below the permissible value are not reported.

2, FCC Limit for Average Measurement = $41.6667(433.9) - 7083.3333 = 10996.792 \mu\text{V/m} = 80.8 \text{ dBuV/m}$

3, the field strength is calculated by adding the antenna factor, high pass filter loss(if used) and cable loss, and subtracting the amplifier gain(if any) from the measured reading, the basic equation calculation is as follows:

Result = Field Strength + Corrected Factor

Where Corrected Factor = Antenna Factor + Cable Loss + High Pass Filter Loss – Amplifier Gain

4, Average value = Peak Value + Average Factor (duty factor)

The duration of one cycle: 63.40ms

Effective period of the cycle: $(0.570 \times 14) + (1.59 \times 11) \text{ms} = 25.47 \text{ms}$

duty cycle = $25.47 \text{ms} / 63.40 \text{ms} = 0.4017$

Therefore, the average factor is found by $20\log 0.402 = -7.92\text{dB}$

5, Pulse Desensitization Correction Factor

Pulse Width(PW)= 25.47ms, $2/PW = 2/25.47\text{ms} = 0.0785\text{KHz}$, $\text{RBW}(100\text{KHz}) > 2/PW(0.0785\text{KHz})$

Therefore PDCF is not needed.

4. 20DB BANDWIDTH

4.1. The 20dB Bandwidth of Emission limit according to FCC part 15 Section

15.231(c)

The bandwidth of the emission shall be no wider than 0.25% of the center frequency for devices operating above 70MHz and below 900MHz. For devices operating above 900MHz, the emission shall be no wider than 0.5% of the center frequency. Bandwidth is determined at the limit: $433.9\text{MHz} \times 0.25\% = 1084.8\text{KHz}$

4.2. Test Procedure

Spectrum Parameter	Setting
Center Frequency	433.9MHz
RBW	10KHz
VBW	30KHz
Span	500KHz

Set SPA Max hold, Mark peak, -20dB

4.3. Test Setup

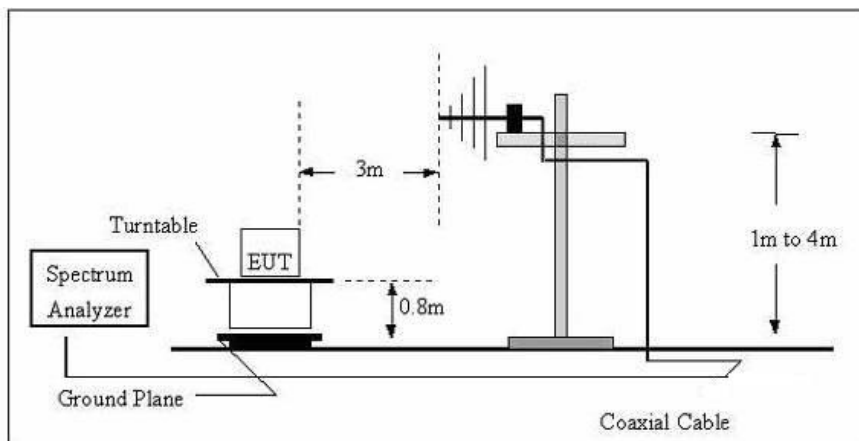

4.4. Test Result

Frequency(MHz)	20dB bandwidth (kHz)	Limit(kHz)	Result
433.9	51	1084.8	Pass

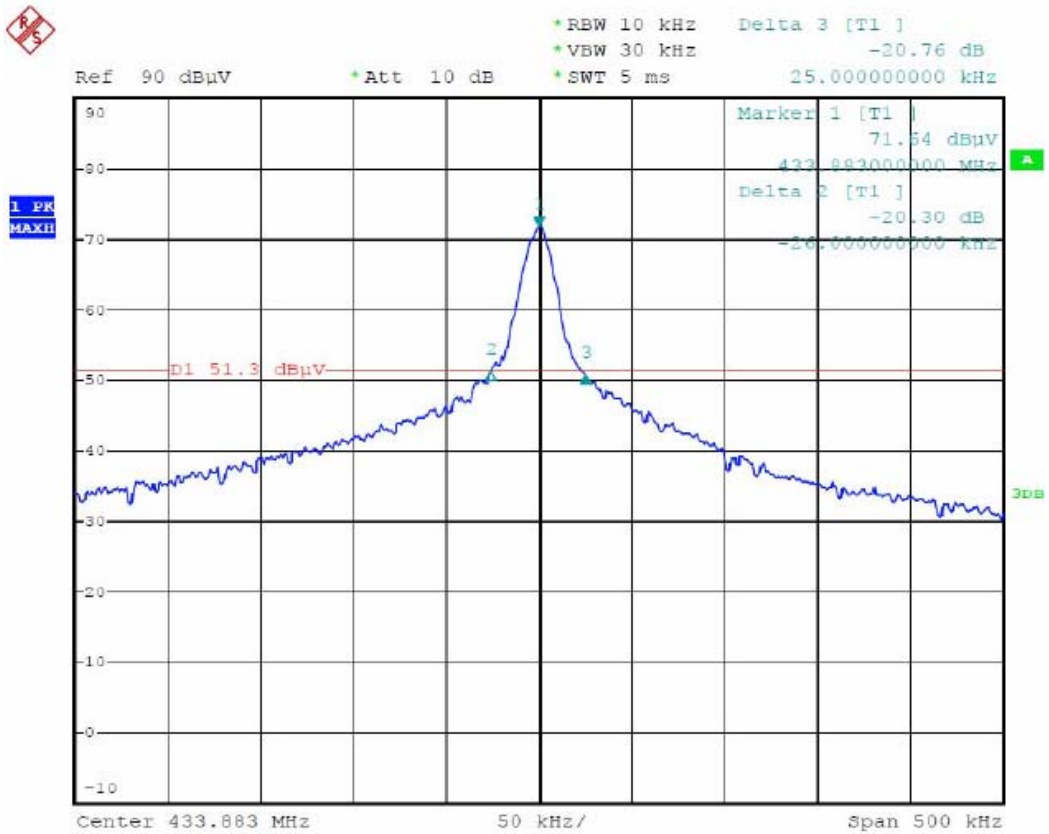

5. TRANSMITTER TIME

5.1. Transmitter Time Measurement According To FCC Part 15 Section 15.231(a)

Section 15.231(a) (2) A transmitter activated automatically shall cease transmission within 5 seconds after activation.

5.2. Test Procedure

Set EUT as normal operation and press transmitter button

Spectrum Parameter	Setting
Center Frequency	433.9MHz
RBW	100KHz
VBW	300KHz
Span	0Hz
Sweep time	10s

Set SPA View, Delta Mark time

5.3. Test Setup

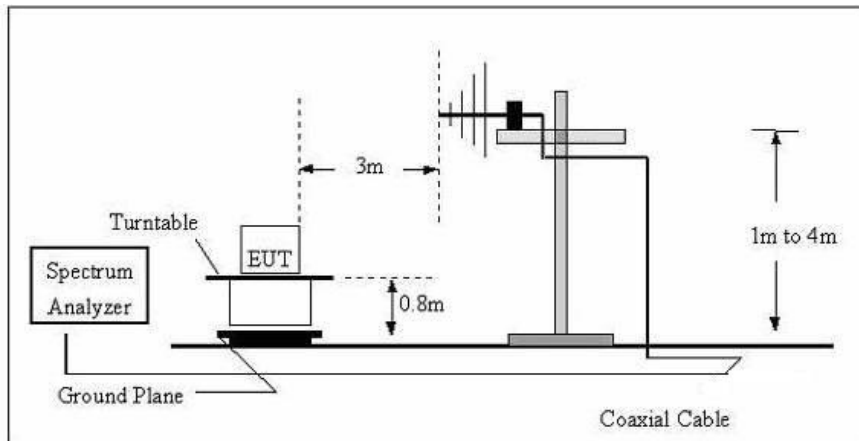

5.4. Test result

Transmitter time(s)	Limit(s)	Result
3.28S	<5S	Pass

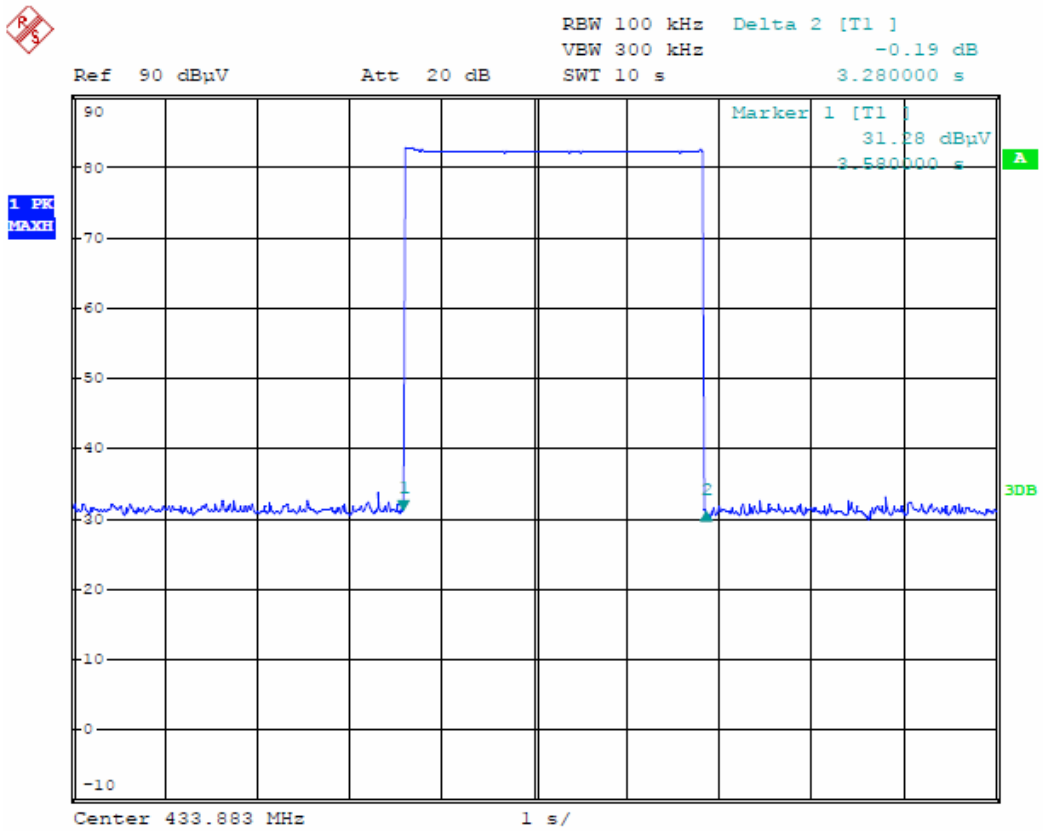

Release Time=3.28s

6. AVERAGE FACTOR MEASUREMENT

6.1. Average Factor Measurement According to ANSI C63.4:2009

ANSI C63.4:2009 Section 13.4.2 Devices transmitting pulsed emissions and subject to a limit requiring an average detector function for radiated emission shall initially be measured with an instrument that uses a peak detector. A radiated emission measured with a peak detector may then be corrected to a true average using the appropriate factor for emission duty cycle. This correction factor relates the measured peak level to the average limit and is derived by averaging absolute field strength over one complete pulse train that is 0.1s, or less, in length. If the pulse train is longer than 0.1s, the average shall be determined from the average absolute field strength during the 0.1s interval in which the field strength is at a maximum. Average factor in dB=20log(duty cycle)

6.2. Test Procedure

The time period over which the duty cycle is measured is 100milliseconds, or the repetition Cycle, whichever is shorter time frame. The worst case(highest percentage on) duty cycle is Used for the calculation

Spectrum Parameter	Setting
Center Frequency	433.9MHz
RBW	100KHz
VBW	300KHz
Span	0Hz

Set EUT as normal operation
Set SPA View, Delta Mark time

6.3. Test Setup

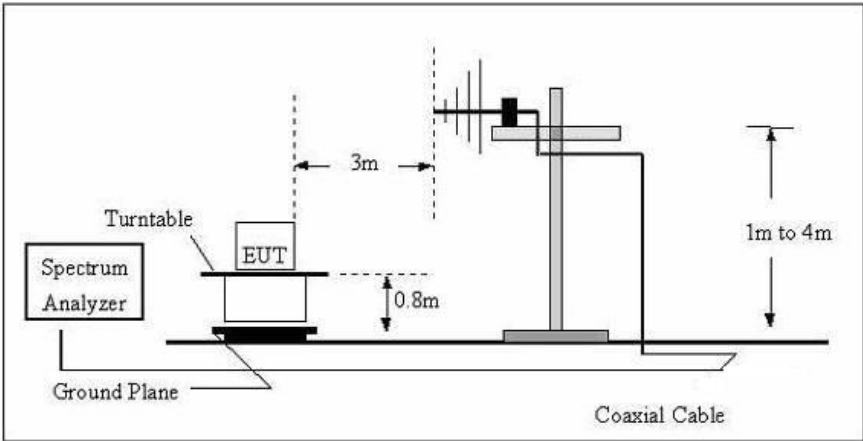

6.4. Test Result

The duty cycle is simply the on time divided by the period:
 The duration of one cycle: 63.40ms
 Effective period of the cycle: $(0.570 \times 14) + (1.59 \times 11) \text{ms} = 25.47 \text{ms}$
 duty cycle = $25.47 \text{ms} / 63.40 \text{ms} = 0.4017$
 Therefore, the average factor is found by $20 \log 0.402 = -7.92 \text{dB}$

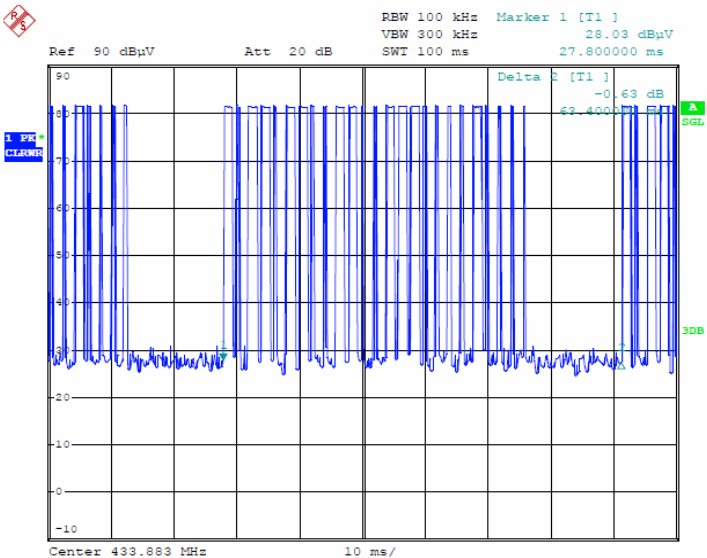

The graph shows the pattern of coding during the signal transmission
 The duration of one cycle = 63.4 ms.

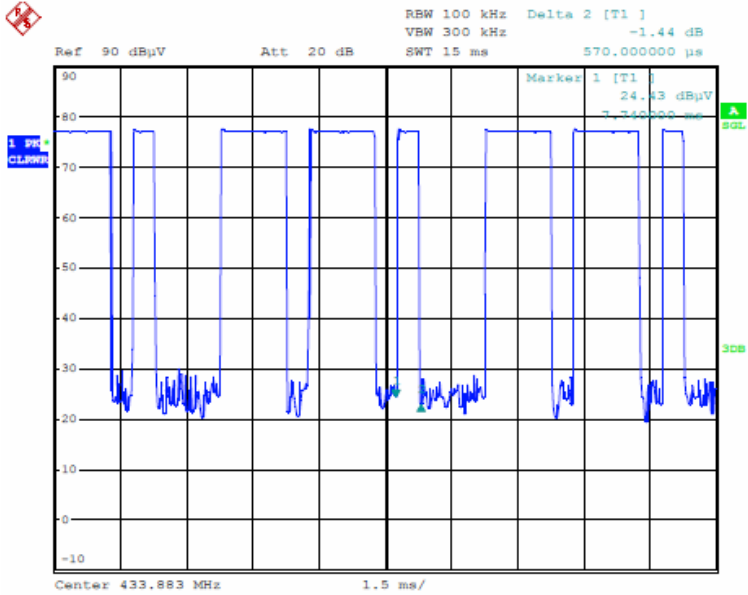

The graph shows the duration of ‘on’ signal. From marker 1 to marker 2, duration is 0.57ms.

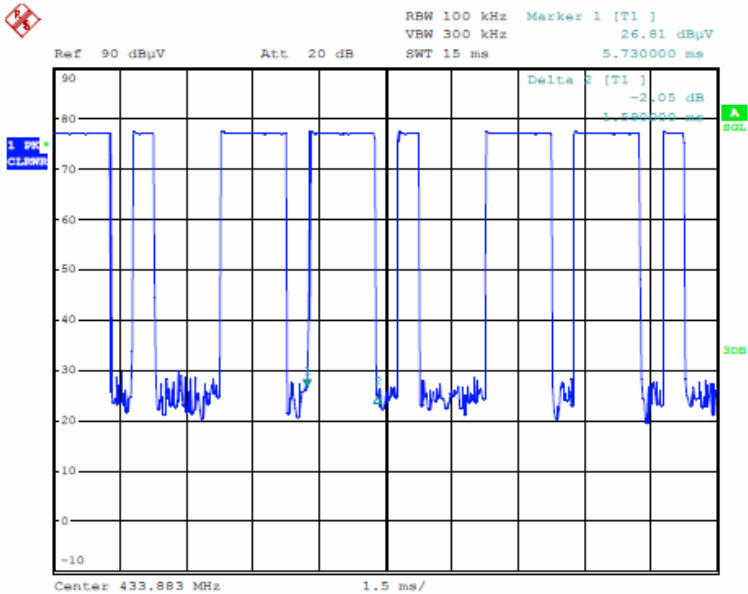

The graph shows the duration of ‘on’ signal. From marker 1 to marker 2, duration is 1.59 ms.

7. ANTENNA REQUIREMENT

Requirement(s): 47 CFR §15.203

An intentional radiator shall be designed to ensure that no antenna other than that furnished by the responsible party shall be used with the device.

The EUT antenna is permanent attached antenna. Therefore the EUT complies with Section 15.203 of the FCC rules.

ANTENNA

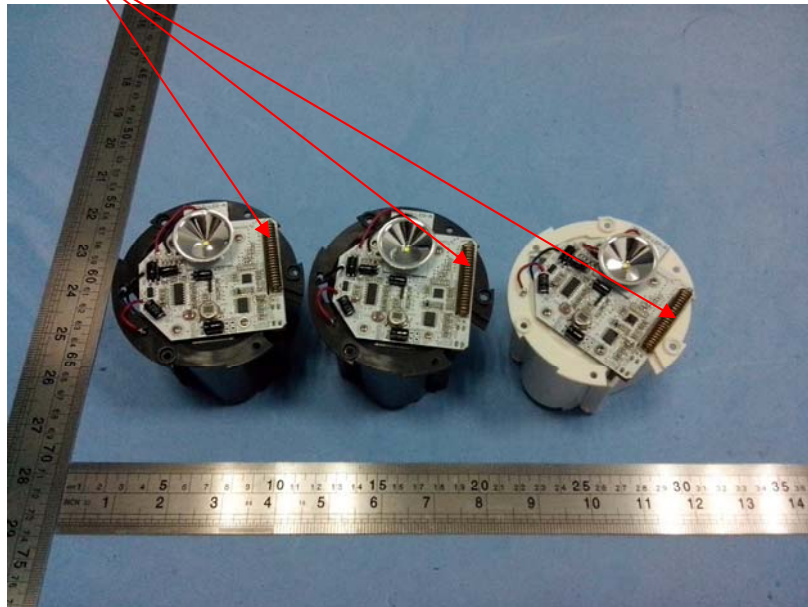

8. PHOTOGRAPH OF TEST

Below 1GHz
9KHz-30MHz

EUT

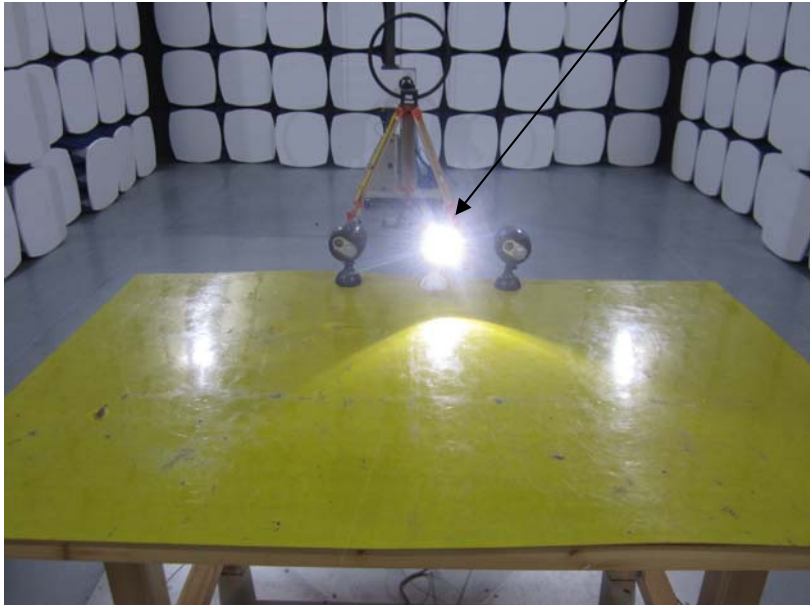

30MHz-1000MHz

EUT

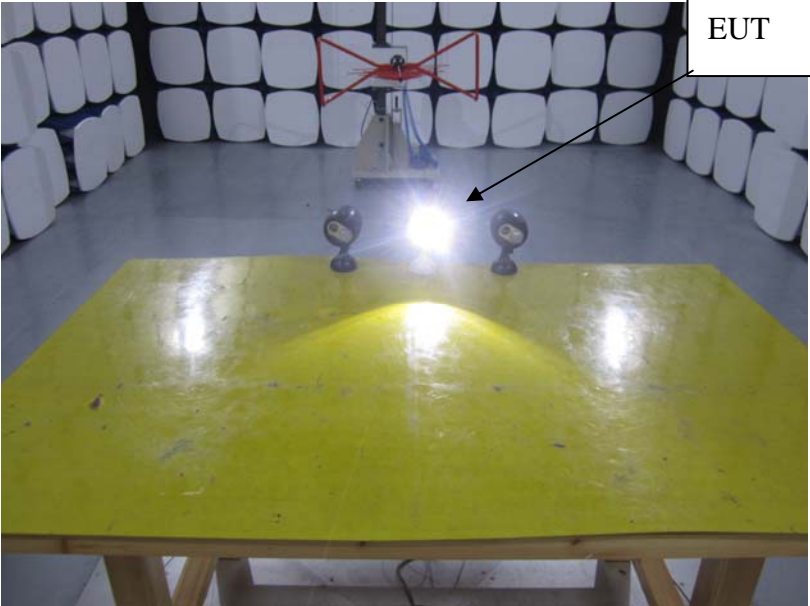

Above 1GHz

EUT

