

SOLiD Responder

Public Safety 700/800 MHz Digital Repeater

SRDR-33-7080-A-FN

User Manual



Version 1.0

8/8/2017

Preface

The user documentation set of SOLiD Responder consists of following main statements:

- SOLiD Responder SRDR-33-7080-A-FN User Manual: Precautions and instructions for installing and setting up SRDR-33-7080-A-FN.

Copyright

All rights are reserved ©2017 SOLiD. Confidential and proprietary. Information contained in this document is company private to SOLiD and should not be modified, used, copied, reproduced or disclosed in whole or in part without the written consent of SOLiD.

Trademark Information

No right, license, or interest to SOLiD Responder trademarks is granted here. By using this document, you agree not to assert any right, license, or interest with respect to such trademark. Other product names mentioned in this manual are used for identification purposes only and may be trademarks or registered trademarks of their respective companies.

Disclaimer of Liability

The contents of this document, including graphics and screenshots, are current as of the date of publication. SOLiD reserves the right to change the contents without prior notice. In no event shall SOLiD be liable for any damages resulting from loss of data, loss of use or loss of profits. SOLiD further disclaims any and all liability for indirect, incidental, special, consequential or other similar damages. This disclaimer of liability applies to all products, publications and services during and after the warranty period.

Getting Support and Providing Feedback

To authorize technical support or to establish a return authorization for defective units, make sure you have the SOLiD serial numbers available. Serial numbers are located on the bottom of the product, as well as on the box in which it was delivered. Contact SOLiD for additional support information:

Contact Information

SOLiD Gear, Inc. Headquarters

Address: 800 Klein Road, Suite 200, Plano, TX 75074

Phone: 888.409.9997

Email for support issues: support@solid.com

Web site: www.solid.com

Revision History

Revision Number	Issue Date	Changes
1.0	Aug 8th, 2017	Initial Release

Contents

1	General Information	10
1.1	Safety Notices	10
1.2	FCC Notices	12
1.3	Industry Canada(IC) Notices	14
1.4	Antenna Installation Notices.....	16
1.4.1	Antenna Requirements	16
1.4.2	Donor Antenna Requirements	16
1.4.3	Service Antenna Requirements	16
2	Product Overview	17
2.1	Introduction.....	17
2.2	Main Features	17
2.3	Ordering Information	18
2.4	Signal Flow.....	19
2.5	Description of Modules.....	20
2.5.1	Integrated PSU	20
2.5.2	Power Amplifier Unit (PAU)	20
2.5.3	Digital Unit (DU).....	20
2.5.4	Radio Frequency Unit (RFU)	20
2.5.5	CPU	20
2.5.6	Multiplexer.....	21
2.5.7	Signal Analysis Module (SAM)	21
2.6	External Interface	22
2.7	Operation.....	23
2.7.1	Classes and Passbands Types	23
2.7.2	Procedure to Choose Passband.....	26
2.7.3	Automatic Shutdown of Amplifiers.....	30
3	Installing the SOLiD RESPONDER.....	32
3.1	Overview of the Installation Procedure	32
3.2	Location Installation Site	33
3.2.1	Product Dimension	33
3.2.2	Installation Environment	34
3.3	Unpacking and Package Contents.....	34

3.4	Mounting the Product	35
3.4.1	Mounting Method	35
3.4.2	Installation the Wall Mount Bracket	36
3.4.3	Rack Mount Installation	36
3.5	Grounding.....	36
3.6	Antenna Connections and Guidelines.....	38
3.6.1	Donor Antenna Installation Guidelines	38
3.6.2	Indoor Antenna Installation Guidelines.....	38
3.6.3	RF Cable Installation Guidelines	38
3.6.4	Connecting Antennas	38
3.7	Connecting Power Cables and Power-up	39
3.7.1	Integrated PSU	39
3.7.2	Power Redundancy	39
3.7.3	AC Power Cabling	40
3.7.4	DC Power Cabling	41
3.7.5	Power Up	41
3.8	Connecting NFPA Alarms	42
3.8.1	Choose the alarms to be monitored	42
3.8.2	Select the type of external alarms	42
3.8.3	Connect cable to the alarm box.....	43
3.8.4	Verify the state of connection	43
4	Setup and Commissioning	44
4.1	Overview of the Commissioning Procedure.....	44
4.2	Connecting the GUI to the Product	45
4.2.1	Network Information of GUI	45
4.2.2	Log in GUI.....	46
4.2.3	GUI Main Screen	46
4.3	Configuring Operation Mode of the Product	48
4.3.1	Operation Mode Window	48
4.3.2	Changing Operation Mode.....	49
4.3.3	Filter Mode.....	49
4.3.4	Echo Cancellation.....	49
4.3.5	Power Supply Configuration	49
4.3.6	AMP Shutdown function	50
4.3.7	Summary.....	50

4.4	Setup Channel Configuration & RF parameters	51
4.4.1	Input the information of service channels	51
4.4.2	Setup Parameters of Digital Filter.....	51
4.4.2.1	Pre-Configured Filter Mode	51
4.4.2.2	36 Channelized Filters	53
4.5	Isolation Measurement & Tune-up.....	55
4.5.1	Monitor Downlink Input Power	55
4.5.2	Measure the isolation between donor antenna and service antenna	55
4.5.3	Evaluate isolation value & reconfigure the antenna installation	55
4.5.4	Test coverage area	56
4.5.5	Verify UL gain and Performs test calls	56
4.6	SNMP traps & Time Settings	57
5	Administrations	58
5.1	Viewing General Information	58
5.2	Alarm Remedy.....	59
5.3	Alarm Log	61
5.3.1	Alarm History	61
5.3.2	Alarm Mask / Shutdown	62
5.4	Firmware Upgrade.....	63
6	Appendix	64
6.1	Environmental Specification	64
6.2	Radio Frequency Specification	65
6.3	Digital Filter Specification	66
6.3.1	Public Safety 700 MHz Band–Selective (Class B)	66
6.3.2	Public Safety 800 MHz Band –Selective (Class B)	66
6.3.3	Public Safety 700 & 800 MHz Channel–Selective (Class A).....	67
6.4	Power Supply Specification.....	68
6.5	Mechanical Specification.....	69

List of Figures

Figure 1. FCC Part 90 Class Information in the GUI	12
Figure 2. Signal Flow of SRDR-33-7080-A-FN	19
Figure 3. Inner View of the SRDR-33-7080-A-FN	20
Figure 4. External Connectors	22
Figure 5. The Spectrum of M701	24
Figure 6. The Spectrum of M702	24
Figure 7. The Spectrum of M703	24
Figure 8. The Spectrum of M801	24
Figure 9. The Spectrum of M802	25
Figure 10. The Spectrum of M803	25
Figure 11. The Spectrum of M036 excluding FirstNet	25
Figure 12, The Spectrum of M036 including FirstNet	25
Figure 13. 3 times Failure in Shutdown Algorithm Type 1	30
Figure 14. 2 times Failure in Shutdown Algorithm Type 1	30
Figure 15. Shutdown Algorithm Type 2.....	31
Figure 16. Dimensions of SRDR-7080-A-FN	33
Figure 17. Mount Bracket for Wall and Rack	35
Figure 18. Dimensions used to install Product on the Wall	35
Figure 19. The Location of Ground Lug	37
Figure 20. Information of Terminal.....	37
Figure 21. Connection for AC-UPS site	39
Figure 22. Connection for DC-UPS site	39
Figure 23. Connections with AC & Batteries.....	40
Figure 24. AC Cable Drawing	40
Figure 25. DC Cable Drawing	41
Figure 26. Relay Output Cable Drawing	43
Figure 27. External Alarm Emulator.....	43
Figure 28. GUI Port of SOLiD Responder.....	45
Figure 29. Login Window	46

Figure 30. Main Screen of GUI	46
Figure 31. System Operation Mode Window	48
Figure 32. Power Supply Configuration	49
Figure 33. AMP Shutdown Function	50
Figure 34. Summary of Selecting the Operation Modes.....	50
Figure 35. Service Channels Window.....	51
Figure 36. Pre-Configured Filter Mode Window.....	52
Figure 37. Channelized Filter Mode Window	53
Figure 38. Isolation Measurement Window.....	55
Figure 39. SNMP Configuration	57
Figure 40. System Information Window	58
Figure 41. Example of Alarm Remedy.....	60
Figure 42. System Log.....	61
Figure 43. Alarm Mask / Shutdown.....	62
Figure 44. Upgrade / Reset.....	63

List of Tables

Table 1. License Descriptions	18
Table 2. Unit Functions	21
Table 3. Passbands of Class A Device	23
Table 4. Passbands of Class B Device	23
Table 5. Passband Types	23
Table 6. Mechanical Specification	33
Table 7. Packing List of the SRDR-33-7080-A-FN	34
Table 8. Power Supply Specification	39
Table 9. AC Port Pin Description	40
Table 10. DC Port Pin Description	41
Table 11. NFPA Alarm Connection upon the Power Supply configuration.....	42
Table 12. IP address of SOLiD Responder.....	45
Table 13. Access Information to AP.....	45
Table 14. Description of Main Menu	47
Table 15. Description of Operation Mode Items	48
Table 16. Pre-configured Filter Parameters.....	52
Table 17. 36 Channelized Filter Parameters	53
Table 18. Parameters of Time Setting	57
Table 19. Description of System Information	58
Table 20. Description of Alarms	59
Table 21. Description of Terms in the Alarm Mask.....	62

1 General Information

1.1 Safety Notices

“Only qualified personnel should handle the equipment. Any person involved in installation or service of the equipment should understand and follow these safety guidelines.”

General Caution

- ✓ SOLiD assumes no liability for the customer’s or user’s failure to comply with these requirements:
 - Explosive atmospheres - To avoid explosion or fire, do not operate this equipment in the presence of flammable gases or fumes.
 - Lightning danger - Do not install or make adjustments to this equipment during an electrical storm.
- ✓ Do not operate this unit on or close to flammable materials, as the unit may reach high temperatures due to power dissipation.
- ✓ Do not use any solvents, chemicals, or cleaning solutions containing alcohol, ammonia, or abrasives on the equipment.
- ✓ When working with equipment outdoors, make sure to fasten the door or cover securely in an open state to prevent the door from slamming shut by the wind.
- ✓ Use this equipment only for the purpose specified by the manufacturer. Do not carry out any modifications or fit any spare parts which are not sold or recommended by the manufacturer. This could cause fires, electric shock or other injuries.
- ✓ Any local regulations are to be followed when operating repeaters.

Hot Burn Injury

- ✓ Due to the power dissipation, the equipment may reach a very high temperature.



- ✓ Be careful not to touch the heat-sink part or the hot parts inside and outside.
- ✓ Since the temperature goes lower slowly, pay caution after putting off the equipment.

Power Supply Precaution

- ✓ In case of connection to the sealed lead-acid batteries, this equipment is intended for installation in restricted access areas. A restricted access area is an area to which access can be gained only by service personnel through the use of a special tool, lock and key, or other means of security, and which is controlled by the authority responsible for the location.

- ✓ Only service personnel or skilled person should handle the connection procedure between the product and the batteries including auxillary accessories concerning the power supply sources.
- ✓ This power of this system should be supplied with the wiring installed in a normal building.
- ✓ If powered directly from the mains distribution system, it shall be used additional protection, such as overvoltage protection device

Grounding

- ✓ Signal Booster, feeders, donor antenna, service antenna and auxiliary equipment (splitters, tabs, .etc) are required to be bonded to protective grounding using the bonding stud or screw provided with each unit.

Dangerous Electric Shock

- ✓ Obey all general and regional installation and safety regulations relating to work on high voltage installations, as well as regulations covering correct use of tools and personal protective equipment.
- ✓ The power supply unit in repeaters contains dangerous voltage level, which can cause electric shock. Switch the main power supply off prior to any work in such a repeater.

Electrostatic Discharge

- ✓ Static electricity means no risk of personal injury but it can severely damage essential parts of the Signal
- ✓ Parts on the printed circuit boards as well as other parts in the Signal Booster are sensitive to electrostatic discharge.
- ✓ Never touch printed circuit boards or uninsulated conductor surfaces unless absolutely necessary.
- ✓ If you must handle printed circuit boards or uninsulated conductor surfaces, use ESD protective equipment, or first touch the Signal Booster chassis with your hand and then do not move your feet on the floor.
- ✓ Never let your clothes touch printed circuit boards or uninsulated conductor surfaces.

Disposal of Electric and Electronic Waste

- ✓ Pursuant to the WEEE EU Directive electronic and electrical waste must not be disposed of with unsorted waste. Please contact your local recycling authority for disposal of this product.
- ✓ Dispose of used batteries according to the instructions in accordance with legal laws.



1.2 FCC Notices

FCC Part 90 statement

- ✓ This equipment complies with Title 47 CFR Parts 90.
- ✓ This is a 90.219 Class **B** device.

WARNING: This is a 90.219 Class **B** device.

This is **NOT** a **CONSUMER** device. It is designed for installation by **FCC LICENSEES** and **QUALIFIED INSTALLERS**. You **MUST** have an **FCC LICENSE** or express consent of an FCC Licensee to operate this device. You **MUST** register Class B signal boosters (as defined in 47 CFR 90.219) online at www.fcc.gov/signalboosters/registration. Unauthorized use may result in significant forfeiture penalties, including penalties in excess of \$100,000 for each continuing violation.

- ✓ Home/personal use are prohibited.
- ✓ The installation procedure must result in the signal booster complying with FCC/ISED requirements 90.219(d)/RSS-131 Sec.6.3 & 6.4. In order to meet FCC/ ISED requirements, it may be necessary for the installer to reduce the UL and/or DL output power for certain installations.
- ✓ Use of unauthorized antennas, cables, and/or coupling devices not conforming with ERP/EIRP and/or indoor-only restrictions is prohibited.
- ✓ If all the passbands are no wider than 75 KHz, the equipment will be Class A device. Otherwise it is Class **B** device. User can also check FCC part 90 Class from the **System Information** window.

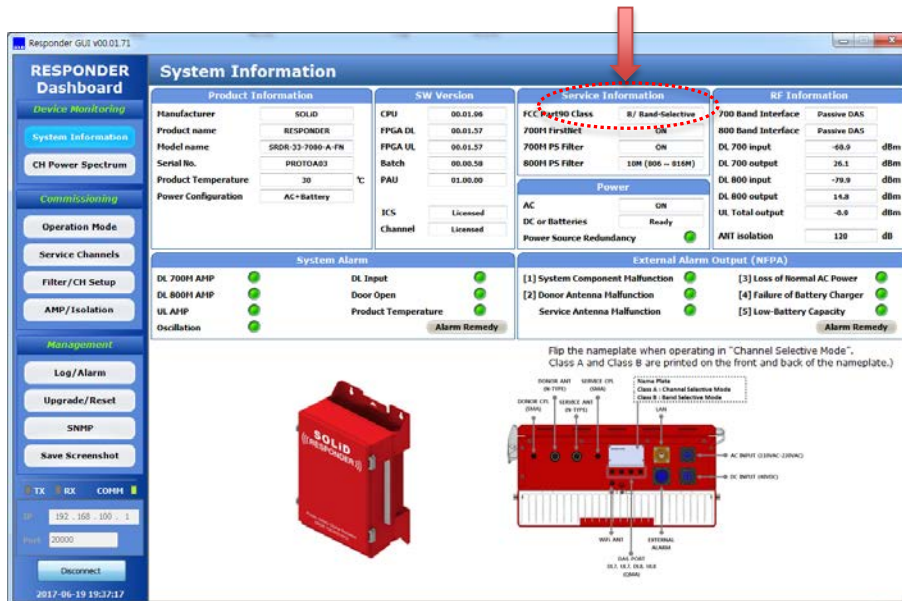

Figure 1. FCC Part 90 Class Information in the GUI

- ✓ If you are unsure, contact your provider.

FCC Part 15 statement

- ✓ This device complies with Part 15 of the FCC Rules. Operation is subject to the following two conditions: (1) this device may not cause harmful interference, and (2) this device must accept any interference received, including interference that may cause undesired operation.
- ✓ Changes or modifications not expressly approved by the party responsible for compliance could “void” the user's authority to operate this equipment.
- ✓ This equipment has been tested and found to comply with the limits for a Class A digital device, pursuant to part 15 of the FCC Rules. These limits are designed to provide reasonable protection against harmful interference when the equipment is operated in a commercial environment. This equipment generates, uses, and can radiate radio frequency energy and, if not installed and used in accordance with the instruction manual, may cause harmful interference to radio communications. Operation of this equipment in a residential area is likely to cause harmful interference in which case the user will be required to correct the interference at his own expense.

Radiofrequency Radiation Exposure Limits

This equipment complies with FCC radiation exposure limits set forth for an uncontrolled environment. In order to avoid the possibility of exceeding the FCC radio frequency exposure limits, human proximity to the antenna shall not be less than 200 cm during normal operation. This device must not be co-located or operating in conjunction with any other antenna or transmitter.

1.3 Industry Canada(IC) Notices

This device complies with Industry Canada license-exempt RSS standard(s). Operation is subject to the following two conditions: (1) this device may not cause interference, and (2) this device must accept any interference, including interference that may cause undesired operation of the device.

Le présent appareil est conforme aux CNR d'Industrie Canada applicables aux appareils radio exempts de licence. Son exploitation est autorisée aux deux conditions suivantes: (1) .il ne doit pas produire de brouillage; et (2) il doit accepter tout brouillage radioélectrique subi, même si celui-ci est susceptible d'en compromettre le fonctionnement.

RSS-GEN, Sec. 7.1.2 – (transmitters)

Under Industry Canada regulations, this radio transmitter may only operate using an antenna of a type and maximum (or lesser) gain approved for the transmitter by Industry Canada. To reduce potential radio interference to other users, the antenna type and its gain should be chosen so that the equivalent isotropically radiated power (e.i.r.p.) is not more than that necessary for successful communication.

Conformément à la réglementation d'Industrie Canada, le présent émetteur radio peut fonctionner avec une antenne d'un type et d'un gain maximal (ou inférieur) approuvé pour l'émetteur par Industrie Canada. Dans le but de réduire les risques de brouillage radioélectrique à l'intention des autres utilisateurs, il faut choisir le type d'antenne et son gain de sorte que la puissance isotroperayonnée équivalente (p.i.r.e.) ne dépasse pas l'intensité nécessaire à l'établissement d'une communication satisfaisante.

RSS-GEN, Sec. 7.1.2 – (detachable antennas)

This radio transmitter (identify the device by certification number, or model number if Category II) has been approved by Industry Canada to operate with the antenna types listed below with the maximum permissible gain and required antenna impedance for each antenna type indicated. Antenna types not included in this list, having a gain greater than the maximum gain indicated for that type, are strictly prohibited for use with this device.

Le présent émetteur radio (identifier le dispositif par son numéro de certification ou son numéro de modèle s'il fait partie du matériel de catégorie I) a été approuvé par Industrie Canada pour fonctionner avec les types d'antenne énumérés ci-dessous et ayant un gain admissible maximal et l'impédance requise pour chaque type d'antenne. Les types d'antenne non inclus dans cette liste, ou dont le gain est supérieur au gain maximal indiqué, sont strictement interdits pour l'exploitation de l'émetteur.

RSS-102 RF Exposure

This equipment complies with RF radiation exposure limits set forth for an uncontrolled environment. This equipment should be installed and operated with a minimum distance of 200 cm between the radiator and your

body. This transmitter must not be co-located or operating in conjunction with any other antenna or transmitter. RF exposure will be addressed at time of installation and the use of higher gain antennas may require larger separation distances.

L'antenne (ou les antennes) doit être installée de façon à maintenir à tout instant une distance minimum de au moins 200 cm entre la source de radiation (l'antenne) et toute personne physique. Cet appareil ne doit pas être installé ou utilisé en conjonction avec une autre antenne ou émetteur.

RSS-131 Section 5.3

The Manufacturer's rated output power of this equipment is for single carrier operation. For situations when multiple carrier signals are present, the rating would have to be reduced by 3.5 dB, especially where the output signal is re-radiated and can cause interference to adjacent band users. This power reduction is to be by means of input power or gain reduction and not by an attenuator at the output of the device.

- a. The nominal passband gain (dB): 95dB maximum
- b. The nominal bandwidth: 12.5KHz – 10MHz
- c. The rated mean output power: 33 dBm per each band maximum
- d. The input and output impedances: 50 ohm, 50 ohm

1.4 Antenna Installation Notices

1.4.1 Antenna Requirements

The installation procedure must result in the signal booster complying with FCC requirements 90.219(d). In order to meet FCC requirements 90.219(d), it may be necessary for the installer to reduce the UL and/or DL output power for certain installations. FCC regulation mandate that the ERP of type B signal boosters should not exceed 5W.

Use of unauthorized antennas, cables, and/or coupling devices not conforming with ERP/EIRP and/or indoor-only restrictions is prohibited. Only 50 ohm rated antennas, cables and passive equipment shall be used with this equipment. Any device attached to this equipment not meeting this standard may cause degradation and unwanted signals in the bi-directional system. All components connected to this device must operate in the frequency range of this device.

1.4.2 Donor Antenna Requirements

- ✓ Maximum Service Antenna Gain is calculated by the below formula.
[ERP] – [nominal output power] – [cable Loss]
- ✓ Yagi or similar type: Directional antenna with a sharp beam, at maximum 17 dBi
- ✓ At minimum cable loss is 5 dB
- ✓ Example of the available antenna specification
 - ◆ $EIRP = 27 \text{ dBm (UL output power)} - 5 \text{ dB (Cable Loss)} + 17 \text{ dBi (Antenna gain)} = 39 \text{ dBm}$
 - ◆ $ERP = EIRP - 2.15 \text{ dB} = 39 - 2.15 = 36.85 \text{ dBm} < 37 \text{ dBm (FCC limit)}$

1.4.3 Service Antenna Requirements

- ✓ Maximum Service Antenna Gain is calculated by the below formula.
[ERP] – [nominal output power] – [cable Loss] – [allocated power]
- ✓ Omni antenna with 0 – 2 dBi gain, Patch antenna with wide beam of 10 dBi gain, At maximum 17 dBi
- ✓ At minimum 5 antennas and splitters
- ✓ At minimum cable loss is 10 dB
- ✓ Example of the available antenna specification
 - ◆ $EIRP = 33 \text{ dBm (DL output power)} - 7 \text{ dB (Splitter Loss)} - 5 \text{ dB (Cable loss)} + 17 \text{ dBi (Antenna gain)} = 38 \text{ dBm}$
 - ◆ $ERP = EIRP - 2.15 \text{ dB} = 38 - 2.15 = 35.85 \text{ dBm} < 37 \text{ dBm (FCC limit)}$

2 Product Overview

2.1 Introduction

SRDR-33-7080-A-FN is an excellent product from SOLiD, which is the signal booster to support public safety radio services typically indoors. It was designed to give great benefits to agents such as First Responder, fire fighters to communicate each other under the emergency as well as a normal situation. And it provides customers the effective solution from the point of total cost of ownership, survivability, flexibility to the circumstance, and easy installation.

SRDR-33-7080-A-FN is a dual band digital repeater to choose the various digital filters with several delays and several rejections. It features 36 FPGA-based, software-controlled, and user-selectable filters across 700 & 800 MHz bands. It can help you configure the best operation to eliminate the adjacent interference and to mitigate the Time Difference Interference (TDI) problem. So, it can be configured as FCC part 90. Class A device or FCC part 90. Class B device. User should follow instructions which are described in 1. 2 FCC notices in case of class B device.

2.2 Main Features

- NFPA/IFC Compliant
- Dual-Band 700/800 MHz & 2W per Band
- FirstNet Support
- Channel-Selective & Band-Selective by user-selectable software
- Integrated Battery Charger and Alarming
- Operation at 60°C and Extended Life
- Simple and Low-powered Active DAS interface

2.3 Ordering Information

Table 1. License Descriptions

SRDR-33-7080-A-FN	Digital Repeater, 2 Watt, 700/800 MHz Public Safety + FirstNet, Band selective, NEMA4, NFPA/IFC Compliant.
SRDR-33-L1	Digital Repeater Channel Selective License Upgrade
SRDR-33-L2	Digital Repeater Echo Cancellation License Upgrade
SRDR-33-L3	Digital Repeater System Analysis Module License Upgrade, includes plugin module

The SOLiD RESPONDER is available from the factory in four different configurations. The base configuration defaults to a “Band Selective” device and does not include the Echo Cancellation or System Analysis features. The base configuration can be factory upgraded by purchasing any, or all, of the three additional licensable software configurations. Refer to the following descriptions or consult your local SOLiD Sales Engineer for guidance in selecting the best product configuration for your application.

SRDR-33-7080-A-FN (Base Configuration)

This Part Number represents the base configuration, which includes the Band Selective mode only (FCC Class B Wideband Signal Booster Device). All Class B Signal Booster devices must be registered with the FCC prior to operation.

SRDR-33-L1 (Channel Selective Software Upgrade)

This license upgrade adds a Channel Selective mode allowing the user to switch between Band Selective and Channel Selective operation. When operating at channel bandwidths of 75KHz or less, this device is classified by FCC as a Class A Narrowband Signal Booster Device, and as such, does not require registration with the FCC. Channel Selective mode is typically used in RF congested areas where narrow pass windows are needed to minimize interference from undesired frequencies. In Channel Selective mode, also known as “Channelized” mode, the user can assign up to 36 window filters, in any increment, between the 700 and 800 MHz bands.

SRDR-33-L2 (Echo Cancellation Software Upgrade)

Echo Cancellation Mode (“ZeroDelta” feature). This license upgrade adds an Echo Cancellation feature to Band and Channel Selective modes. The Echo Cancellation feature includes an advanced patented algorithm that allows the repeater to maintain maximum gain even when system isolation deteriorates to as low as the gain of the repeater. Traditional repeaters require at least 15-20dB more isolation than system gain to prevent oscillation. The “ZeroDelta” feature allows normal operation with 0dB difference between system isolation and system gain. This feature has many advantages such as increased system stability and reliability, easy system commissioning and optimization, and increased coverage footprint and cost savings in applications where weak off-air signals require a high gain setting.

SRDR-33-L3 (System Analysis Module – Hardware and Software Upgrade)

System Analysis Module (SAM). This part number includes a hardware plug-in module and software that enables advanced system analysis, such as: data logging of wideband spectrum to aid in application of window filters, to spectrum analyzer features that display near-real time spectrum readings for both input and output.

2.4 Signal Flow

Below is the block diagram which describes the signal flow in the equipment.

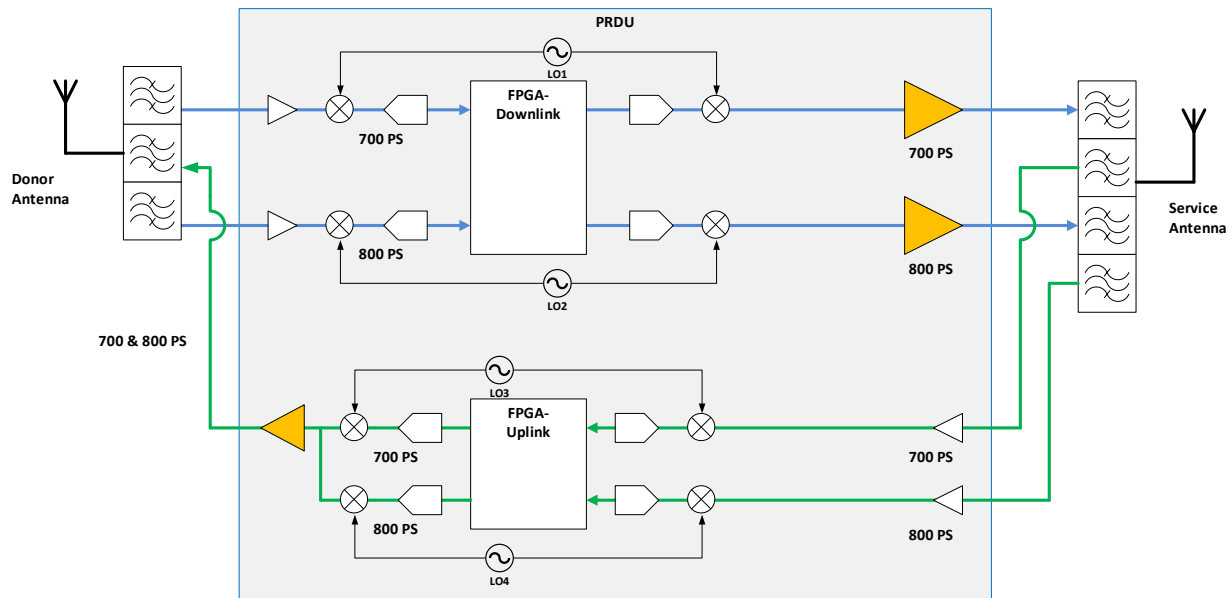

Figure 2. Signal Flow of SRDR-33-7080-A-FN

700 PS stands for the signal that includes Public Safety narrowband (6+6 MHz) and the FirstNet (10+10 MHz). 800 PS stands for the signal that includes NPSPAC (3+3 MHz), PS & Non-Cellular SMR (6+6 MHz), and Expansion Band (1+1 MHz).

Off-the-air RF signal that received from the donor antenna is down-converted to the IF signal. It goes to the FPGA after the analog-to-digital conversion, and filtered to remove the unwanted signal. The signal that comes from FPGA is reconstructed in the digital-to-analog converter. And then it would be up-converted by the same local oscillator with the down-conversion. So, its frequency is same to the original signal.

2.5 Description of Modules

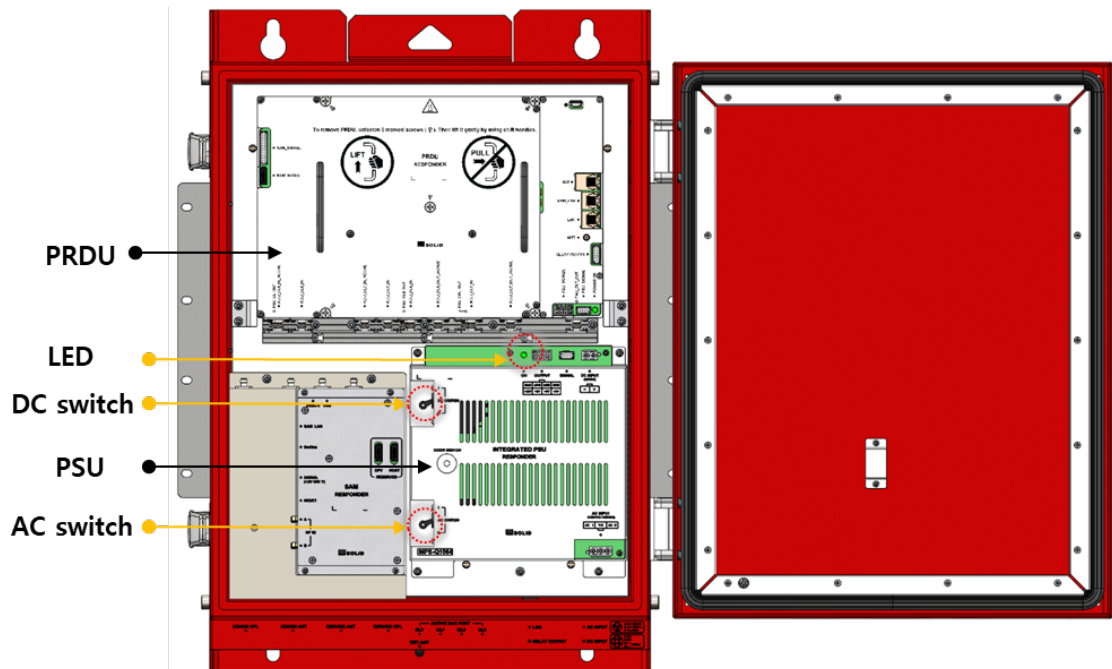

Figure 3. Inner View of the SRDR-33-7080-A-FN

2.5.1 Integrated PSU

The integrated PSU consists of AC to DC power supply, DC to DC power supply, and the 48V battery charger. This feature enables to operate with AC power source and batteries for redundancy.

2.5.2 Power Amplifier Unit (PAU)

This unit amplifies a low-power signal to the high-powered RF signal.

2.5.3 Digital Unit (DU)

The unit performs a powerful digital filtering.

2.5.4 Radio Frequency Unit (RFU)

Each signal on the 700 & 800 MHz band is converted into the signal with an intermediate frequency to be filtered. For high input power it is attenuated to prevent the saturation in the analog-to-digital converter. The signal which comes from the digital-to-analog converter is also converted into the signal with an original radio frequency.

2.5.5 CPU

This unit controls and monitors every module except for multiplexer. After connecting the product to PC, user set up parameters to operate via GUI software. And it will monitor and store all status to be chosen.

2.5.6 Multiplexer

Multiplexer combines several signals of multiple paths into those of one path. And it acts vice versa. This module is made up of cavities.

2.5.7 Signal Analysis Module (SAM)

This is a hardware plug-in module with a high processing power and it enables advanced system analysis, such as: data logging of wideband spectrum to aid in application of window filters, to spectrum analyzer features that display near-real time spectrum readings for both input and output.

Table 2. Unit Functions

No.	Unit	Description
1	Integrated PSU	AC input : 100 – 120 VAC, DC input: 48 – 56 VDC, Batteries input: 43 – 56 VDC Output: 29V, 5V
2	PAU	Filters and amplifies highly downlink signals in 700 MHz band irrespectively Filters and amplifies highly downlink signals in 800 MHz band irrespectively Filters and amplifies highly uplink signals in 700 MHz band & 800 MHz band
3	DU	Filters signals Cancels echo signals and amplifies original input signals
4	RFU	Down-converts and up-converts the frequencies of signals Attenuates and amplifies signals
5	CPU	Controls each unit to operate Monitors the defined status of each unit Can be accessed by Ethernet and 2.4 GHz Wi-Fi
6	Multiplexer	Separates a downlink signal which comes from the donor antenna into signal in the 700 band and the signal in the 800 band. And combines vice versa for uplink signal. Combines two downlink signals which come from RFU into one signal to the service antenna and separates vice versa for uplink signal.
7	Enclosure	Enclosure to satisfy NEMA4 Can be mounted on the Wall/Rack

2.6 External Interface

All external connectors are located in the bottom side of the product.

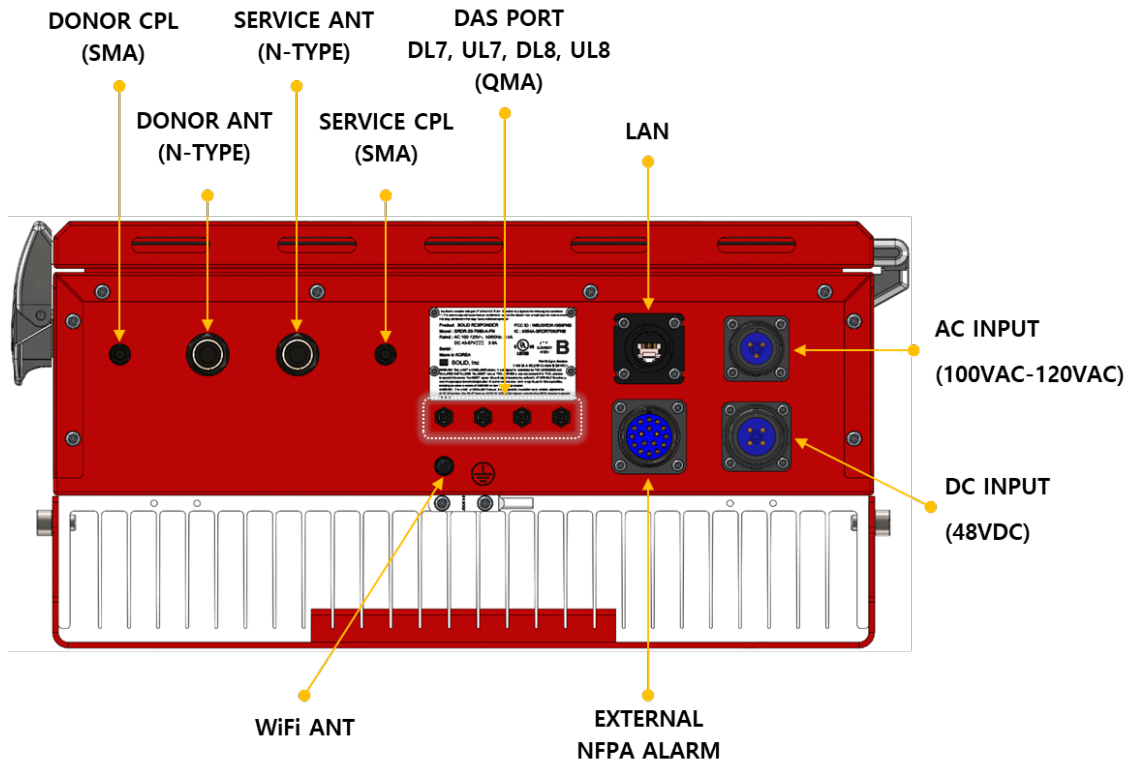

Figure 4. External Connectors

2.7 Operation

2.7.1 Classes and Passbands Types

The class of device which is defined in the FCC part 90 is distinguished by the below passbands and each bandwidth of channel filter. And it is enabled by the digital filter which user can choose appropriately under the circumstance.

Table 3. Passbands of Class A Device

Bands	Category	Downlink	Uplink
700 MHz	PS narrowband	769 – 775 MHz	799 – 805 MHz
800 MHz	Public Safety	851 - 861 MHz	806 - 816 MHz

Table 4. Passbands of Class B Device

Bands	Category	Downlink	Uplink
700 MHz	LTE	758 – 768 MHz	788 – 798 MHz
	PS narrowband	769 – 775 MHz	799 – 805 MHz
800 MHz	Public Safety	851 - 861 MHz	806 - 816 MHz

There are 2 different passband types for our equipment. Below is the table which describes the name and the FCC part 90 Class.

Table 5. Passband Types

License	Passband Type	Mode Number	FCC part 90 Class
Basic (Band-Selective)	Pre-configured Band Filters	M701	Class B Device
		M702	Class B Device
		M703	Class B Device
		M801	Class B Device
		M802	Class B Device
		M803	Class B Device
SRDR-33-L1 (Channel-Selective)	Channelized Filters	M036	Class A Device

All the spectrum examples per mode numbers are presented below. The blue squares denotes the digital filters, and the vertical lines in them denotes the radio signals. The dark blue ones are service channels, and the red ones are interferences.

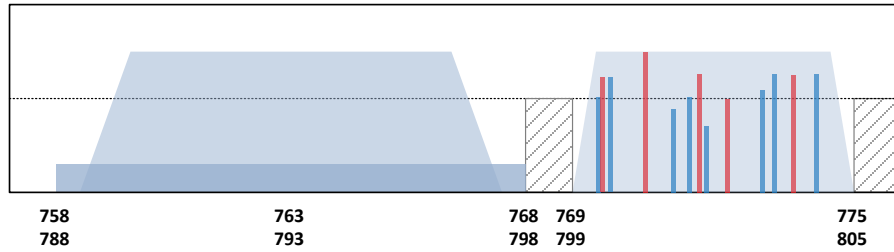

Figure 5. The Spectrum of M701

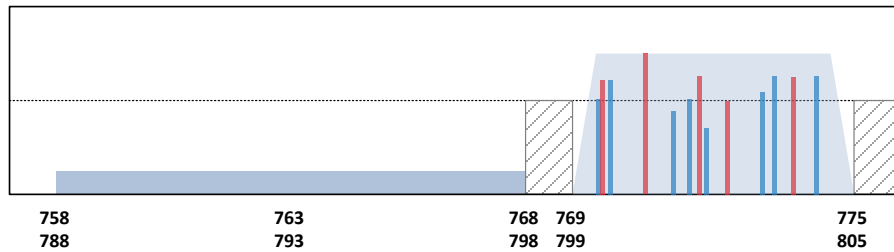

Figure 6. The Spectrum of M702

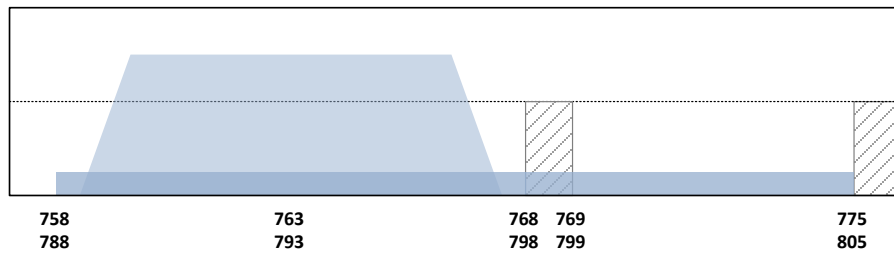

Figure 7. The Spectrum of M703

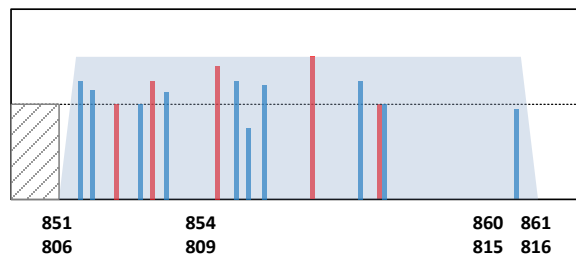

Figure 8. The Spectrum of M801

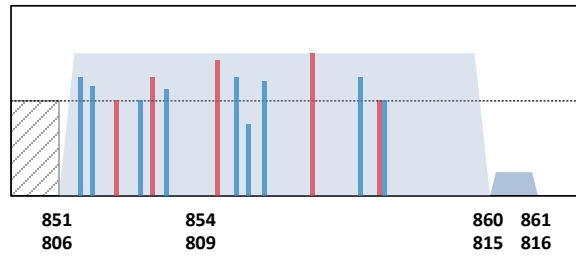

Figure 9. The Spectrum of M802

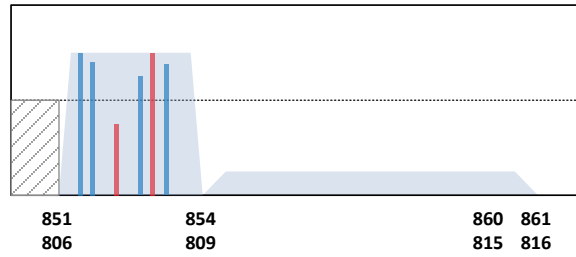
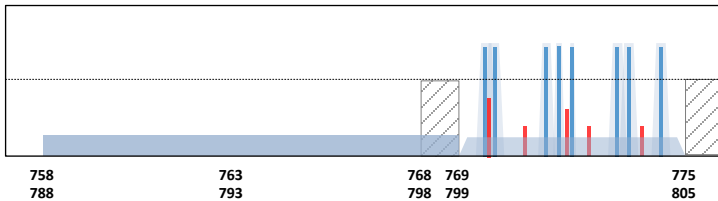

Figure 10. The Spectrum of M803

700 Channel-Selective Spectrum excluding FirstNet



800 Channel-Selective Spectrum

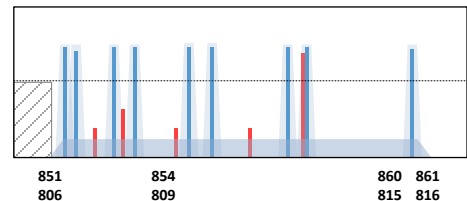
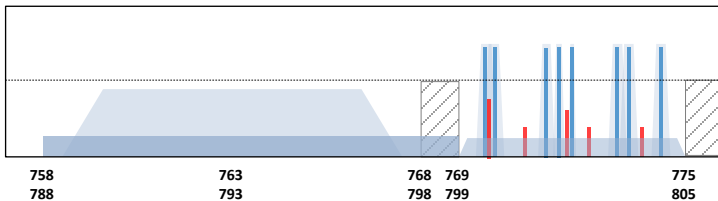

Figure 11. The Spectrum of M036 excluding FirstNet

700 Channel-Selective Spectrum including FirstNet



800 Channel-Selective Spectrum

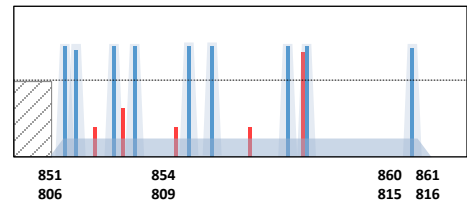

Figure 12, The Spectrum of M036 including FirstNet

2.7.2 Procedure to Choose Passband

From the GUI for setup the equipment, user can choose one passband type among the possible several alternatives. It is noticed that a specific passband type named **M036** is only available if SRDR-33-L1 license exists. The procedure of choice passband's type is executed by the wizard in the GUI.

Below are pictures which are captured in the GUI. User configures digital filters in the step 3.

Step 1

Click Operation Mode Wizard

Service Frequency Band	[700M] FirstNet, Public Safety	ON	[800M] Public Safety	ON
Band Selective	<input checked="" type="checkbox"/> 750 - 775 MHz, 780 - 805 MHz PASSBAND 769 - 775 MHz, 799 - 805 MHz 758 - 768 MHz, 788 - 799 MHz		<input type="checkbox"/> 851 - 861 MHz, 806 - 816 MHz PASSBAND 851 - 860 MHz, 806 - 815 MHz 851 - 854 MHz, 806 - 809 MHz	
Channel Selective	<input type="radio"/> 36 Channelized Filters Mode <i>Licensed - Factory Test</i>			
Echo Cancellation	<input type="radio"/> Echo Cancellation ON <i>Licensed - Factory Test</i>			
DAS Interface	<input type="button" value="PA output"/>		<input type="button" value="PA output"/>	

Step 2

Choose the service band

Service Frequency Band
Select the service radio frequency

- Enable 700 Band & 800 Band
- Enable 700 Band Only
- Enable 800 Band Only

< Back **Next >** Finish Cancel

Step 3-1

Configure Operation Mode

Digital Filters Mode
Select the digital filter group

Pre-Configured Filters Mode

36 Channelized Filters Mode (Need for Information of the Service Channels)

< Back Next > Finish Cancel

Choose the passband types among the 3 options.

➔ Pre-configured Filter

A step is followed by step 3-1

Configure Operation Mode

Passband of 700 Band
Select the passband among the pre-configured modes

758 – 775 MHz, 788 – 805 MHz (FN+PSNB)

769 – 775 MHz, 799 – 805 MHz (PSNB Only)

758 – 768 MHz, 788 – 799 MHz (FN Only)

< Back Next > Finish Cancel

Choose the detailed passband option among the pre-configured filters in Public Safety 700 MHz band.

Another step is followed by step 3-1

Configure Operation Mode

Passband of 800 Band
Select the passband among the pre-configured modes

851 – 861 MHz, 806 – 816 MHz (NPSPAC+SMR+EB)

851 – 860 MHz, 806 – 815 MHz (NPSPAC+SMR)

851 – 854 MHz, 806 – 809 MHz (NPSPAC Only)

< Back Next > Finish Cancel

Choose the detailed passband option among the pre-configured filters in Public Safety 800 MHz band.

Step 3-2

Configure Operation Mode

Digital Filters Mode
Select the digital filter group

Pre-Configured Filters Mode
 36 Channelized Filters Mode (Need for Information of the Service Channels)

Note that it will be required for the rebooting process.

Choose the passband types among the 3 options.

➔ **36 Channelized Filter**

Step 4

Configure Operation Mode

DAS Interface
Choose the output path for the service

for 700 Band

Power Amp output
 Bypass the power amplifier to the DAS

for 800 Band

Power Amp output
 Bypass the power amplifier to the DAS

Choose the DAS Interface

➔ choose the output port to the service antenna

Step 5

Configure Operation Mode

Power Supply Configuration
Select the power topology of the installed site

AC & 48V batteries with Charger With Power Saving @Threshold [°C]

AC only
 DC 48V only (Disable Charger)

Choose the power supply configuration

➔ choose the redundancy type of power source

Step 6

Configure Operation Mode

PA Shutdown 

Select the applicability of Power Amplifier Shutdown on the specific condition

Enable PA Shutdown @ High Temperature

Disable PA Shutdown @ High Temperature

Temperature Threshold [°C]

< Back Next > Finish Cancel

Select Power Amplifier's Shutdown for the specific region

Step 7

Configure Operation Mode

Summary 

Review your selections before changing operation mode

[Service Frequency Band]
Enable 700 Band & 800 Band

[Digital Filter Mode]
Pre-Configured Mode

[Passband of 700 Band]
758 – 775 MHz, 788 – 805 MHz (FirstNet + 700 PS)

[Passband of 800 Band]
851 – 861 MHz, 806 – 816 MHz (10 MHz + 10 MHz)

[DAS Interface]
Power Amp output for 700 Band
Power Amp output for 800 Band

[Power Supply Configuration]
AC & 48V batteries with Charger
Disable Power Saving Mode

< Back Next > Finish Cancel

Report the summary of the user selection.

2.7.3 Automatic Shutdown of Amplifiers

The equipment has an automatic shutdown function to protect the power amplifiers themselves and the wireless network when the normal operational conditions cannot be maintained. The conditions of the shutdown RF power amplifier are below.

A. High Output Power from RF Power Amplifier (Shutdown Algorithm type 1)

The equipment shut down the power amplifier automatically if the composite output power exceed the threshold level for 10 seconds. The level can be set through GUI. Once an automatic shutdown occurs, the equipment will turn on power amplifier automatically in 10 seconds to assess the power amplifier’s condition. If the shutdown condition is detected again, the equipment will shut down the power amplifier. It tries to do this process up to 3 times. If the shutdown condition is released, it continues to operate. After an automatic shutdown occurs 3 times continuously, an automatic recovery is terminated. So, to turn on power amplifier is only possible by setting PA operation in the GUI. The following diagram shows this shutdown algorithm type 1.

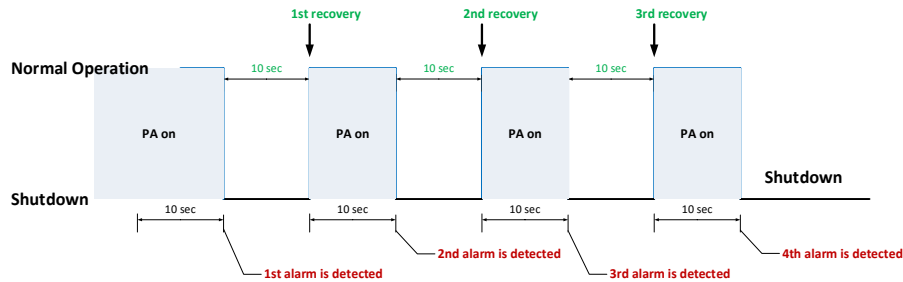

Figure 13. 3 times Failure in Shutdown Algorithm Type 1

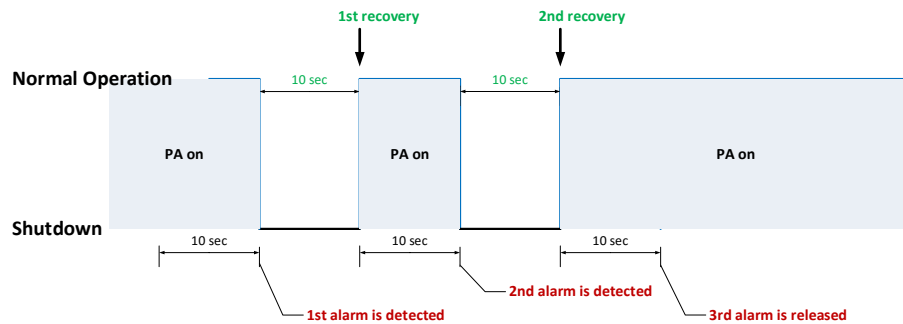

Figure 14. 2 times Failure in Shutdown Algorithm Type 1

B. High Input Power from RF Power Amplifier (Shutdown Algorithm type 2)

The equipment shut down the power amplifier automatically if the composite input power exceed the threshold level for 10 seconds. The level can be set through GUI. Once an automatic shutdown occurs, if only the shutdown condition is released, the equipment would turn on power amplifier automatically. The following diagram shows this shutdown algorithm type 2.

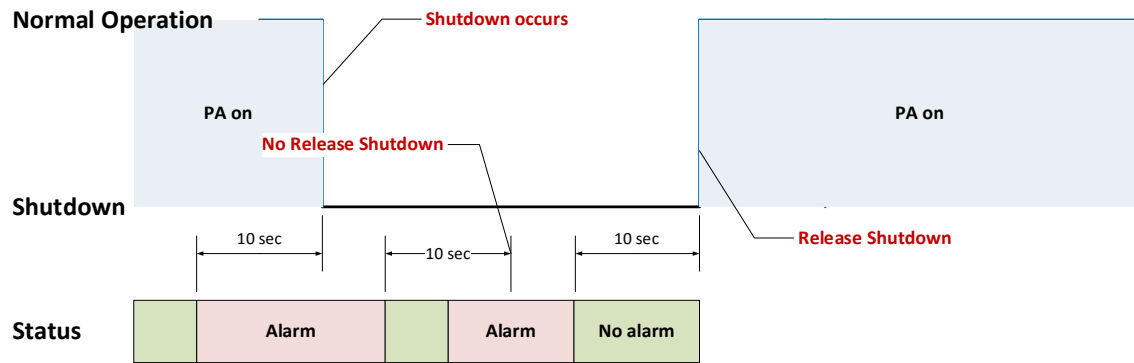

Figure 15. Shutdown Algorithm Type 2

C. High Temperature at RF Power Transistor (Shutdown Algorithm type 2)

The equipment shut down the power amplifier automatically if the composite input power exceed the threshold level for 10 seconds. The level can be set through GUI. Once an automatic shutdown occurs, if only the shutdown condition is released, the equipment would turn on power amplifier automatically. The following diagram shows this shutdown algorithm type 2.

3 Installing the SOLiD RESPONDER

3.1 Overview of the Installation Procedure



3.2 Location Installation Site

3.2.1 Product Dimension

Below are the dimensions of SRDR-33-7080-A-FN.

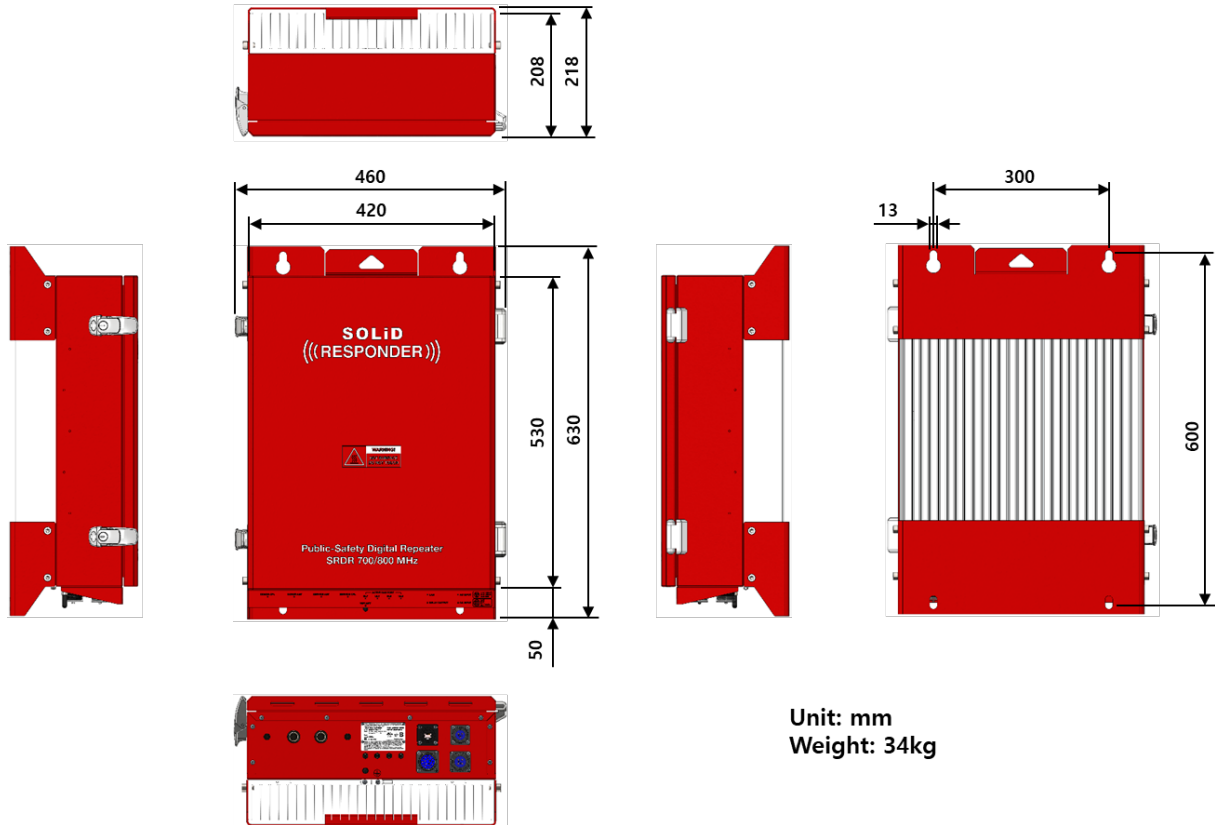

Figure 16. Dimensions of SRDR-7080-A-FN

Table 6. Mechanical Specification

Items	Value	Comments
Dimensions (HxWxD)	530 x 420 x 208 (mm) 20.9 x 16.5 x 8.2 (inches)	Without bump
	630 x 460 x 218 (mm) 24.8 x 18.1 x 8.6 (inches)	With bump
Weight	34kg, 75 lb	
19" Rack Mount	Yes	
Operating Temperature	-30 – 60 °C	Ambient Temperature

3.2.2 Installation Environment

The following criteria should be considered when selecting the SOLiD Responder installation site location. During transportation and installation, take necessary handling precautions to avoid potential physical injury to the installation personnel and the equipment.

Input Signal Requirements

- ✓ BTS channels, channel power
- ✓ BTS antenna location, height, gain
- ✓ Distance from the BTS antenna
- ✓ Donor antenna type, gain, and location
- ✓ It is recommended that the installation location be as close as possible to the donor antenna site in order to reduce the cable loss to a minimum.

Environmental Requirements

- ✓ Use a suitable mounting surface, such as a flat back rigid wall. The SOLiD Responder can be mounted to the 19" rack.
- ✓ The SOLiD Responder is convection cooled, so airflow should be possible.

Electrical Requirements

- ✓ Follow Electro-Static Discharge (ESD) precautions.
- ✓ Verify that the equipment has been well grounded. This includes antennas and all cables connected to the system. Ensure lightning protection for the antennas is properly grounded.
- ✓ The power up procedure should be followed by the connecting all components around the SOLiD Responder to prevent from the electrical damage.
- ✓ Ensure cables are properly routed and secured so that they are not damaged.

3.3 Unpacking and Package Contents

Examine the packing container for damage before unpacking the product. After unboxing, verify that all of the items listed in the packing list are included.

Table 7. Packing List of the SRDR-33-7080-A-FN

No.	Items	Quantity	Description
1	SRDR-33-7080-A-FN	1	The main body of equipment This includes the keys of door inside of door.
2	AC Cable	1	Power cable for AC 100 – 120 VAC
3	DC Cable	1	Power cable for DC 48VDC and 48V line batteries
4	NFPA Alarms Cable	1	External alarms cable for NFPA alarm box. It includes 5 possible alarms which are chosen by user.
5	Water-proof RJ-45 Connector	1	Accessory for the Ethernet cable to connect with the equipment. For SNMP traps.

3.4 Mounting the Product

3.4.1 Mounting Method

SRDR-33-7080-A-FN is designed to be water-proof and dirt-proof. The unit has the structure of One-Body enclosure. It satisfies water-proof and quake-proof standards equivalent of NEMA4.

SOLID RESPONDER can be mounted into either of a 19" Standard Rack or on a Wall. Basically, it has both of a Wall Mount Bracket and a Rack Mount Bracket. Depending on the use of the Rack Mount Bracket, the bracket can be removed. The following shows dimension of the fixing point for the Wall Mount Bracket.

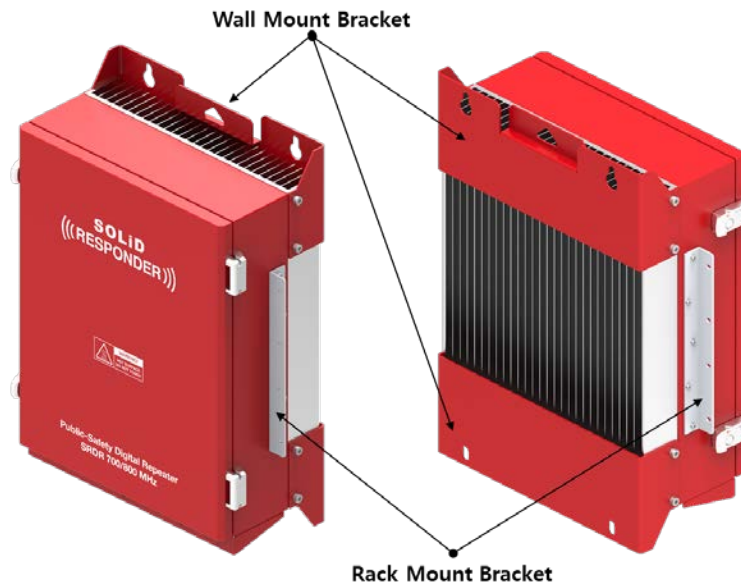

Figure 17. Mount Bracket for Wall and Rack

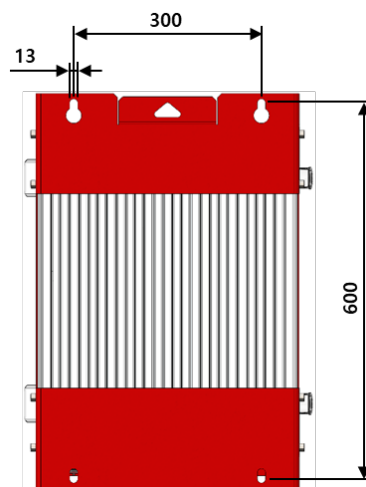

Figure 18. Dimensions used to install Product on the Wall

3.4.2 Installation the Wall Mount Bracket

SRDR-33-7080-A-FN installation bracket is attached on Enclosure when is delivered. It doesn't need to remove bracket to install enclosure. simply after installing 4 of M12 mounting bolts, secure 4 mounting bolts tightly. First, install 2 of M12 mounting bolts roughly half way on the enclosure and install enclosure over the bolts and secure tightly.

Second, install 2 of M12 mounting bolts under the enclosure and secure tightly



3.4.3 Rack Mount Installation

SOLiD RESPONDER would be the best fit to be mounted on 19" standard rack. into a rack. The unit occupies around 15U of space except cable connection.

3.5 Grounding

The Grounding terminal is located at the bottom of heat-dissipating pin in the back of enclosure, and it's fixed by M4 screw. The recommended thickness of cable is AWG#10 – 12 copper grounding wire.

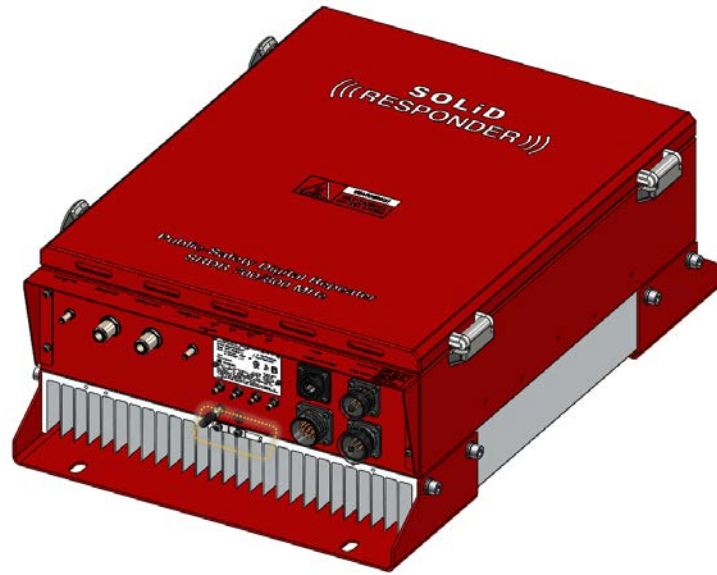

Figure 19. The Location of Ground Lug

The specification of compression terminal is like below.

TUBULAR CABLE LUGS, ONE-HOLE, ROUND COMPRESSED TYPE-CP

- Material : Electrolytic Copper (TPC)
- Surface : Tin Plated
- With Inspection Hole to visually assure full Conductor insertion.
- Color Coded to Show Proper Die Number and Color 10_{min}-70_{max}
- To IEC 60228 Class 2 and Class 5
- UL Listed 486A-486B up to 35KV

Part Number	Wire Range				Stud Size	Dimension (mm)				Code Cable Die Color & No.	Q'ty/ bag
	CODE		FLEX			W	E	L	d		
	AWG	mm ²	AWG	mm ²							
JOCP 16-5					M5	12		29			
JOCP 16-6	6	16	6	16	M6		13	33	5.4	Blue 24	300
JOCP 16-8					M8	14		33			
JOCP 16-10					M10	16		34			

Figure 20. Information of Terminal

The required part number is JOCT 6-2 supporting AWG 12 – 10. The way to install the grounding cable comply with below procedures.

1. Loosen a M4 screws and then take compression terminal off
2. Insert AWG#12~10 Grounding Wire into terminal and then compress a terminal using tool
3. Assemble the terminal which made in step “2” using M4 screws
4. Cut the ground wire to proper length and connect it to the earth ground source (Round terminals located on the side of a 1 mm² (6 AWG) or more wires Using permanently connected to earth.)

3.6 Antenna Connections and Guidelines

3.6.1 Donor Antenna Installation Guidelines

- ✓ Accurately determine the azimuth to the donor site. Obtain the donor site information and approval from the service provider/carrier.
- ✓ Ensure that the radiation path to the donor site is unobstructed.
- ✓ Mount the donor antenna at or toward the edge of the roof, in the direction of the donor site. Avoid having the RF signal from the donor pass above the location(s) of the service antennas. Normally, the service antennas are installed behind and below the donor antenna, as viewed from above. This approach helps avoid interference and feedback to and from the service antennas.
- ✓ Normally, mounting the donor antenna higher will allow a less obstructed path to the donor site. However, in high traffic metro areas, avoid mounting the donor antenna higher than necessary, as the quality of the donor signal may become less stable and it is more likely to encounter adjacent channel interference.
- ✓ When possible, shield the rear of a donor antenna by locating it so that any HVAC units and/or penthouse structures are behind the antenna, relative to the donor cell site location.

3.6.2 Indoor Antenna Installation Guidelines

- ✓ Use omnidirectional antennas indoors and locate them centrally with respect to the intended coverage area to minimize signal leakage to the outside. Only use directional antennas indoors in special cases when higher gain and directionality would be helpful and RF exposure limits will not be exceeded.
- ✓ To avoid Signal Booster uplink overload and gain limiting, mount the indoor antennas away from areas where mobile subscribers frequently use their phones, such as desks or dispatch areas.
- ✓ To determine the quantity and locations of indoor antennas, measure Received Signal Strength Indication (RSSI) using DM Tool software to determine areas of weak signals. These are the approximate areas where indoor antennas may be needed.
- ✓ Be aware that the signal from an indoor antenna, in most cases, can be expected to penetrate approximately two standard sheet rock walls to reach users. If the signal must travel through more than two walls, or if the walls are made of materials other than sheet rock, it may be necessary to split the available signal and add more antennas.

3.6.3 RF Cable Installation Guidelines

- ✓ For all coaxial connections to/from the Signal Booster - high performance, flexible, low loss 50 ohm coaxial communications cable.
- ✓ All cables shall be weather-resistant type.
- ✓ If the coaxial cables are NOT weather-resistant type: wrap the exterior coaxial cables with insulation and holding tape (Type 3M Rubber splicing tape) for environmental protection and to ensure longer lifetime.
- ✓ Cable length - determined by the Signal Booster installation plan. When calculating the cable length, take into account excess cable slack so as not to limit the insertion paths.

3.6.4 Connecting Antennas

- ✓ Connect the Donor and Service antennas.
- ✓ Verify all RF connectors are tightened and the cables and antennas are secured.

3.7 Connecting Power Cables and Power-up

3.7.1 Integrated PSU

The integrated PSU consists of AC to DC power supply, DC to DC power supply, and the 48V battery charger. This feature enables to operate with AC power source and batteries for redundancy. Two external ports such as AC input and DC input have circuit breaker to protect themselves. Below is the table for the power supply specification.

Table 8. Power Supply Specification

Item		Description
Power Supply	AC	100 - 120 VAC
	DC	48 – 56 VDC
	Charger	48V-rail charger for lead-acid batteries with State of Charge detection

3.7.2 Power Redundancy

SRDR-33-7080-A-FN supports AC 120V power source, 48V DC power source, DC 48V batteries and charger. So 3 types of power supply configuration are possible for power redundancy. These block diagrams are below.

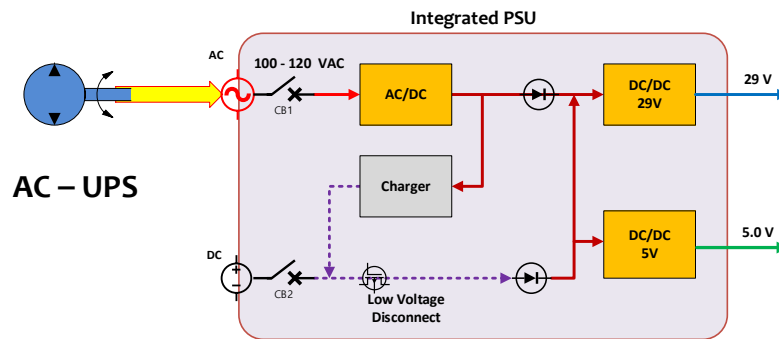

Figure 21. Connection for AC-UPS site

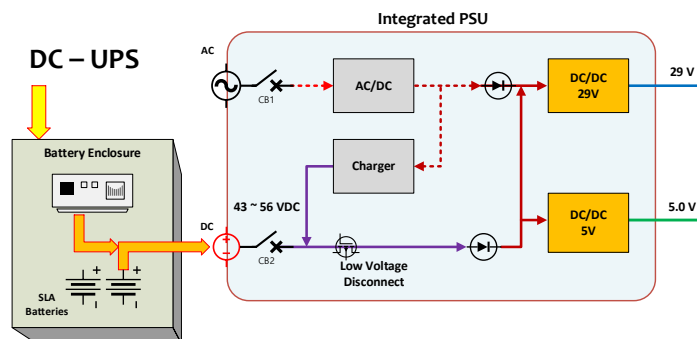

Figure 22. Connection for DC-UPS site

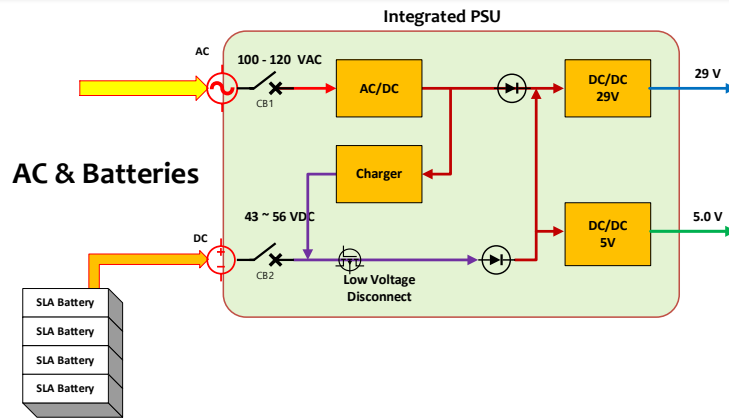

Figure 23. Connections with AC & Batteries

3.7.3 AC Power Cabling

SRDR-33-7080-A-FN supports 100 – 120 VAC input power. The pin discription of AC port is below.

Table 9. AC Port Pin Description

Port Outlook	MS Connector Numbering	Name	Description
	A	AC 120V-H	AC Hot
	B	AC 120V-N	AC Neutral
	C	AC GND	AC Ground

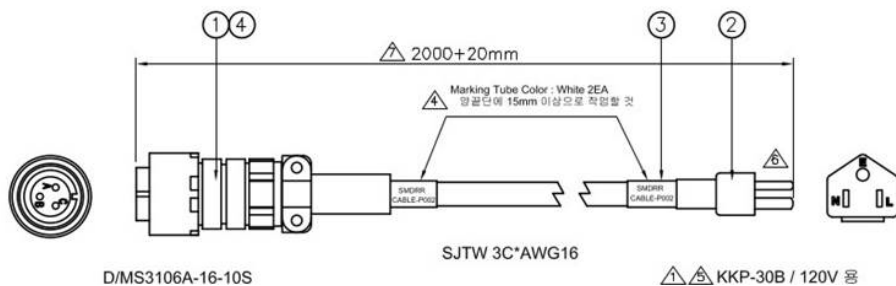

Figure 24. AC Cable Drawing

A provided outside power cable is only one type with AWG#16 & 2m. From the above drawing you can verify it easily. Note that you should match exact polarity of AC voltage. If you use the attached AC cable in the shipping box, you don't need to worry about it. Otherwise the equipment can have an severe damage under power-on. Usually a circuit breaker on AC power line will work to prevent damage under the abnormal situation.

3.7.4 DC Power Cabling

SRDR-33-7080-A-FN supports 48VDC input power. An actual voltage is 43 – 56 VDC of batteries or DC-UPS. The pin discription of DC port is below.

Table 10. DC Port Pin Description

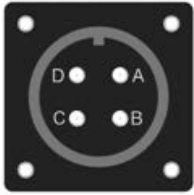
Port Outlook	MS Connector Numbering	Name	Description
	A	NC	Not Connected
	B	NC	Not Connected
	C	+	48VDC
	D	-	

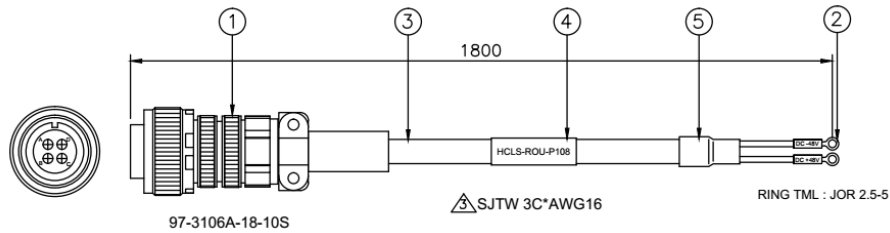

Figure 25. DC Cable Drawing

The provided outside power cable is only one type. From the above drawing you can verify it easily. Note that you should match exact polarity of DC voltage. Otherwise the equipment can have an severe damage under power-on.

3.7.5 Power Up

After verifying the proper connection of wires in the each power cable, power up SRDR-33-7080-A-FN. Don't miss grounding. If an abnormal electrical situation occurs, each circiut breaker on two power lines will work to prevent damage. If you succeed in power up the product, you can see the green LED on the top of the integrated PSU light.

AC power source has a priority over DC power source in the SRDR-33-7080-A-FN. So, in case that two power switches are on, the power up from the DC power source wouldn't performed. You should check the availability of DC power source with AC power switch off.

3.8 Connecting NFPA Alarms

3.8.1 Choose the alarms to be monitored

SOLiD Responder provides upto 5 alarms to be monitored by the external alarm box and SNMP traps. They consist of 2 system alarms and 3 power alarms. Below is the alarms to be provided by the external alarm cable.

Table 11. NFPA Alarm Connection upon the Power Supply configuration

Items	AC & Batteries	AC UPS	DC UPS
System component malfunction.	Connect	Connect	Connect
VSWR-antenna malfunction	Connect	Connect	Connect
Normal AC power, Loss of normal AC power	Connect	Connect	Do Not connect
Battery charger failure	Connect	Do Not connect	Do Not connect
Low battery capacity	Connect	Do Not connect	Do Not connect

According to the power supply configuration, the related 3 power alarms are monitored and masked suitably. But user should connect the proper alarms because the each external alarm signal is dedicated to the fixed wire in the cable, and it's unchanged by software. Below is the proper connection of related output cable with alarm box upon the power supply configuration.

3.8.2 Select the type of external alarms

SOLiD RESPONDER provides 3 pins per every alarm. The first one is a common signal, the second one is normal-open signal, and the third is normal-close signal. Since the alarm state is desired to be sustained under the unpowered situation, 3 wires per an alarm are adopted instead of programmable 2 wires. So, a customer just have to choose an appropriate signal according to the type of alarm box. Below is the table describing the pinout of the relay output. User can recognize the proper wire easily due to the labeling with numbers and colors.

No.	Pin Name	Description	label
1	NC1	A Normal-Closed Signal for System Malfunction	A
2	COM1	A Common Signal for System Malfunction	B
3	NO1	A Normal-Open Signal for System Malfunction	C
4	NC2	A Normal-Closed Signal for Antenna Malfunction	D
5	COM2	A Common Signal for Antenna Malfunction	E
6	NO2	A Normal-Open Signal for Antenna Malfunction	F
7	NC3	A Normal-Closed Signal for AC loss	G
8	COM3	A Common Signal for AC loss	H
9	NO3	A Normal-Open Signal for AC loss	J

10	NC4	A Normal-Closed Signal for a charger failure	K
11	COM4	A Common Signal for a charger failure	L
12	NO4	A Normal-Open Signal for a charger failure	M
13	NC5	A Normal-Closed Signal for the state of charge 70%	N
14	COM5	A Common Signal for the state of charge 70%	P
15	NO5	A Normal-Open Signal for the state of charge 70%	R
16	GND	Signal Ground	S

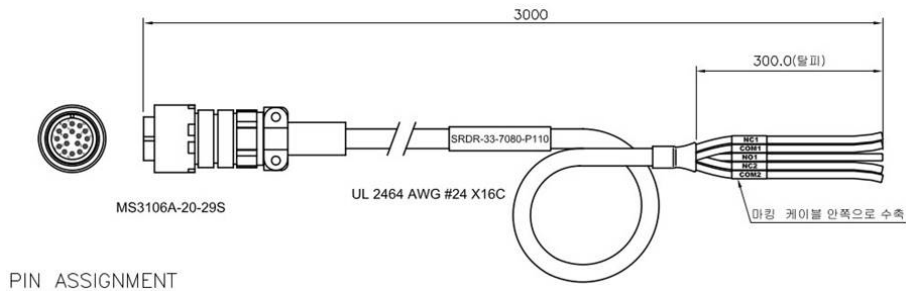

Figure 26. Relay Output Cable Drawing

3.8.3 Connect cable to the alarm box

3.8.4 Verify the state of connection

When a user needs to create external alarms on purpose or for testing, additional feature as shown below can be used. **External Alarm Emulator** can be found in the top side of **Log/Alarm** window in the GUI.

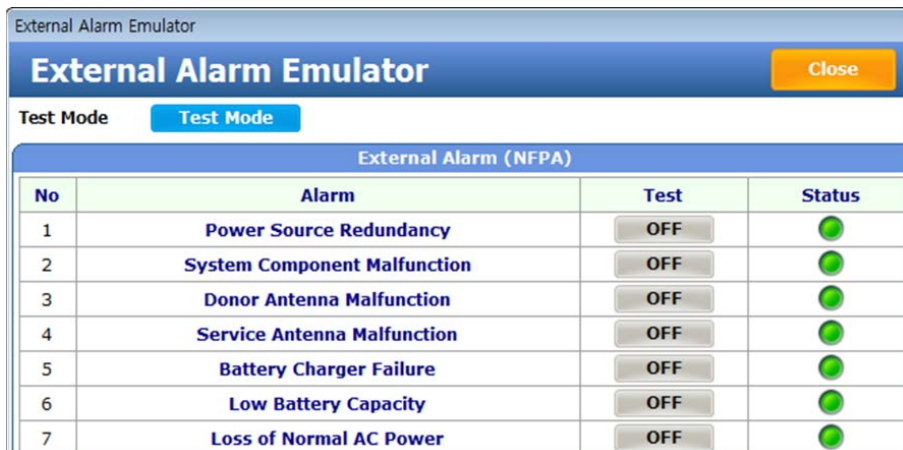
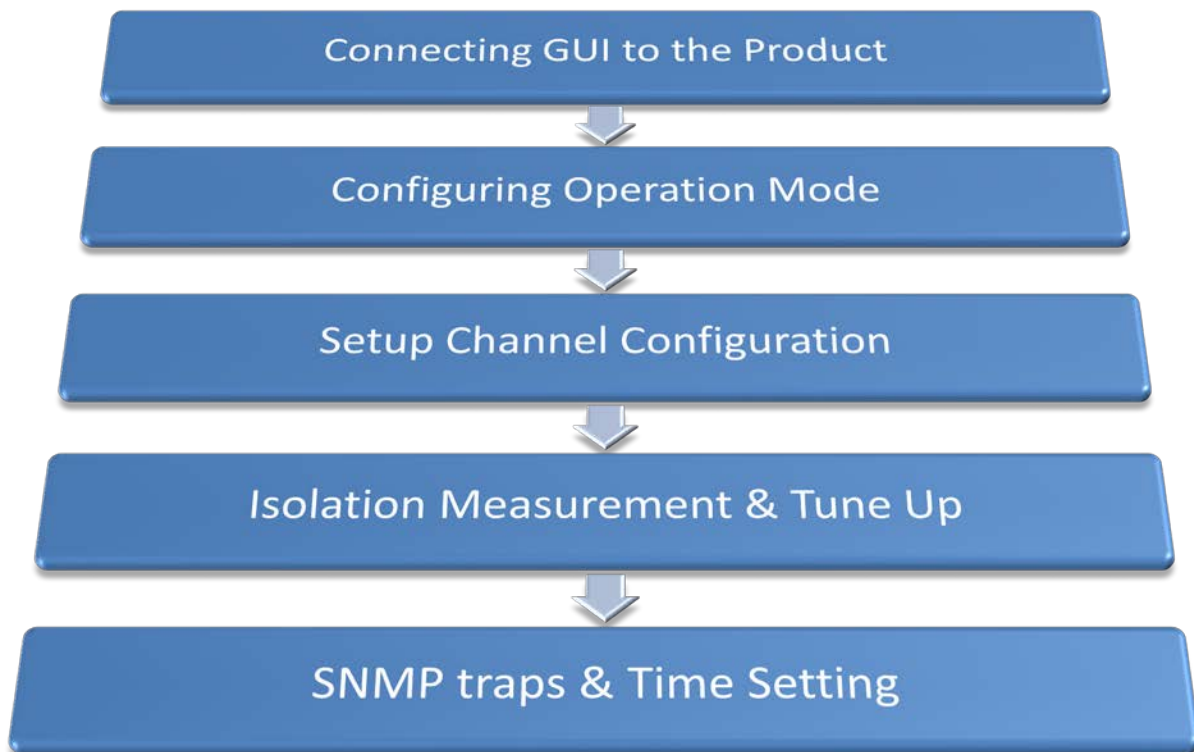

Figure 27. External Alarm Emulator

When you click the ON/OFF button in the window, **External Alarm Emulator** generates the virtual alarm to be verified. You can see the result in the status LED or in the alarm box. When the **External Alarm Emulator** window is closed, to emulate alarms will be cleared.

4 Setup and Commissioning

4.1 Overview of the Commissioning Procedure



4.2 Connecting the GUI to the Product

4.2.1 Network Information of GUI

The computer where the GUI has been installed can be connected with SOLiD Responder through wireless or wired connection. Below is the figure of the wired connection port.

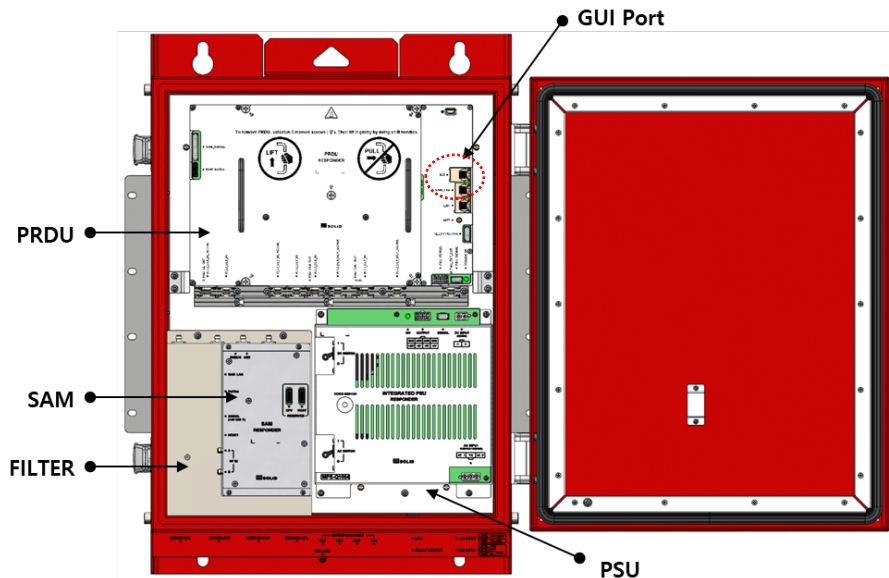

Figure 28. GUI Port of SOLiD Responder

SOLiD Responder has the built-in 2.4GHz Wi-Fi module so that a wireless connection is available without the cable. The computer should be located within the coverage range of 2.4 GHz Wi-Fi, typically hundred feet away. However, if there are obstacles between them, that could affect the communications.

Table 12. IP address of SOLiD Responder

Type	IP Address	Port Number
Wired Connection Via Ethernet (GUI port)	192.168.100.1	20000
Wireless Connection Via 2.4GHz Wi-Fi	192.168.30.1	20000

Table 13. Access Information to AP

SSID of AP	SOLiD_PS_####
Access Password	12345678

4.2.2 Log in GUI

When you click the **Responder GUI** icon, the following window will be popped up.



Figure 29. Login Window

To enter the GUI, type the login password that has been delivered.

4.2.3 GUI Main Screen

Below is the layout of the main screen of GUI.

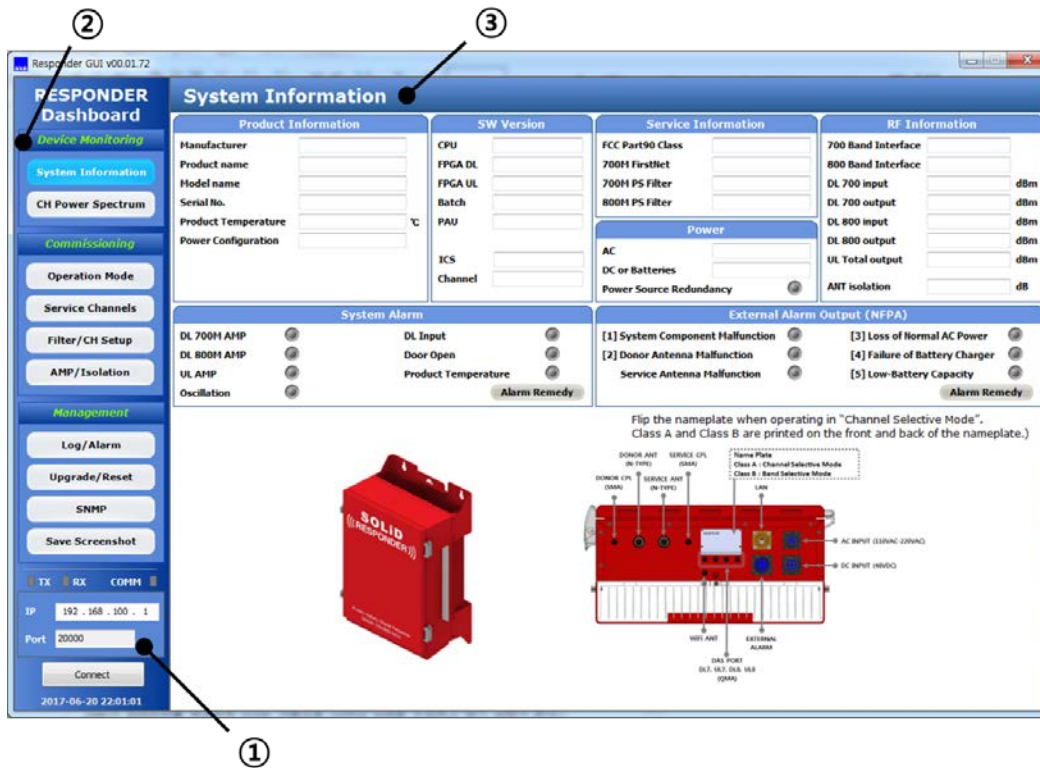

Figure 30. Main Screen of GUI

- ① Communication: it represents the communication status and the connection information with the device.
- ② Main Menu: these are categorized in three parts.
 - A. Device Monitoring: these features are for monitoring the device
 - B. Commissioning: these features are for setting up the device
 - C. Management: these features are for device management.
- ③ Main Window: these features are for checking all the information about the Responder.

Table 14. Description of Main Menu

Item	Descriptions
Device Monitoring	
System Information	It displays current status and alarms of the Responder.
CH Power Spectrum	It displays the information about input/output signals (DL only) and filters of the Responder in the graphs.
Commissioning	
Operation Mode	Users can see the operation mode of the Responder And, It allows users to select a mode to operate the Responder.
Service Channels	It displays frequency information about service channels that are provided in your area.
Filter / CH Setup	It displays information about the filters, channel powers, and gains in the Responder.
AMP / Isolation	It displays the status of the power amplifier and the antenna isolation.
Management	
Log / Alarm	It allows users to set alarms' condition and to check alarm history as well.
Upgrade / Reset	It allows users to update the firmware and to reset the Responder.
SNMP	It allows users to set network parameters and the current time.
Save Screenshot	It allows users to capture the current GUI screen image.

4.3 Configuring Operation Mode of the Product

4.3.1 Operation Mode Window

The below Window shows the operation mode that user has selected or factory setting.

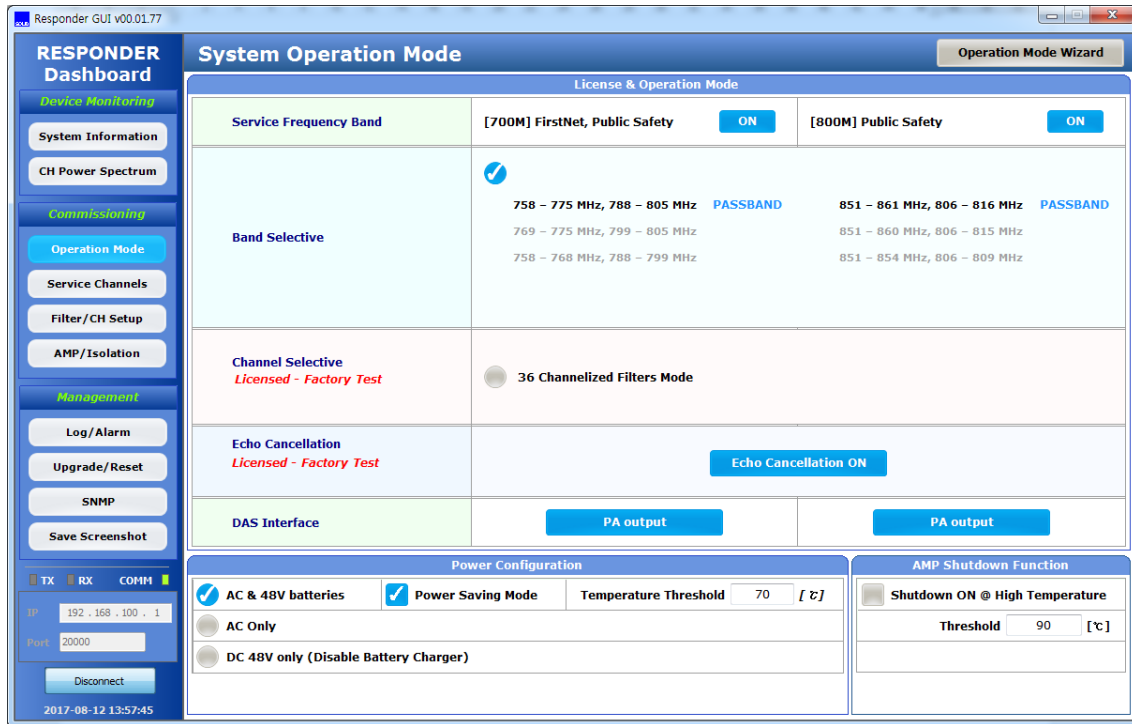

Figure 31. System Operation Mode Window

Table 15. Description of Operation Mode Items

Item	Description
Service Frequency Band	ON/OFF of 700M/800M Path
Band Selective	The selected option is shown among the 2 options. ① Pre-Configured Filter Mode ② 36 Channelized Filter Mode
Channel Selective	The 2 nd option can be possible with the Channel license. The mixed combination of filters across two bands is impossible.
Echo Cancellation	ON/OFF of Echo Cancellation This feature can be chosen with Echo Cancellation license.
DAS Interface	The downlink output and uplink input port to the service antenna
Power Configuration	The power redundancy type for alarms. and the status of the power-saving mode

AMP Shutdown

The status of Shutdown AMP function at the high temperature.

4.3.2 Changing Operation Mode

To change an operation mode, click the **Operation Mode Wizard** button in the top of the window. You can't edit or modify the setting by clicking directly the main window. The operation mode will be changed after press **Finish** button in the popped small window that appears at last stage.

4.3.3 Filter Mode

The Responder supports two types of filters. (Note that you need to have Channel License for using Channelized Filter Mode.)

Item	Description
Band Selective	<p>Pre-Configured Filter Mode</p> <p>ON/OFF of 700M PS NB and 700M FirstNet</p> <p>Passband of 800M PS (with 3, 9, and 10 MHz filters)</p>
Channel Selective (with license)	<p>36 Channelized Filter Mode</p> <p>up to 36 channel filters for 700M and 800M PS</p> <p>Any increment is possible across two bands</p>

4.3.4 Echo Cancellation

The Echo Cancellation feature includes an advanced algorithm that allows the repeater to maintain maximum gain even when system isolation deteriorates to as low as the gain of the repeater. Traditional repeaters require at least 15-20dB more isolation than system gain to prevent oscillation. The **“ZeroDelta”** feature allows normal operation with 0dB difference between system isolation and system gain.

4.3.5 Power Supply Configuration

Select a power supply configuration from the list to report alarms properly. When the **AC & 48V batteries with Charger** is selected, **Power Saving Mode** can be chosen.

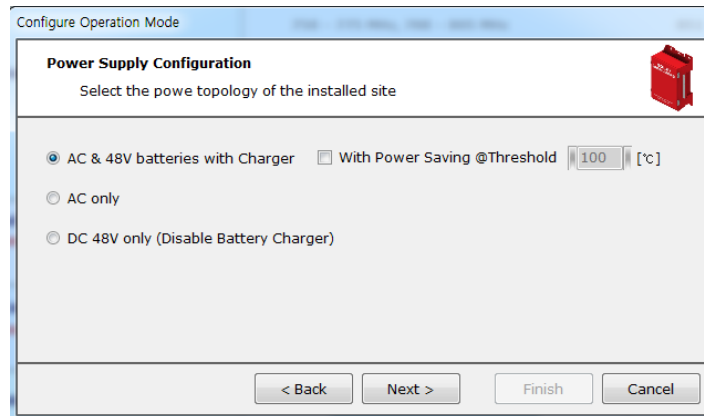

Figure 32. Power Supply Configuration

4.3.6 AMP Shutdown function

It allows users to choose whether to shut down the AMP when the temperature reaches the specific level.

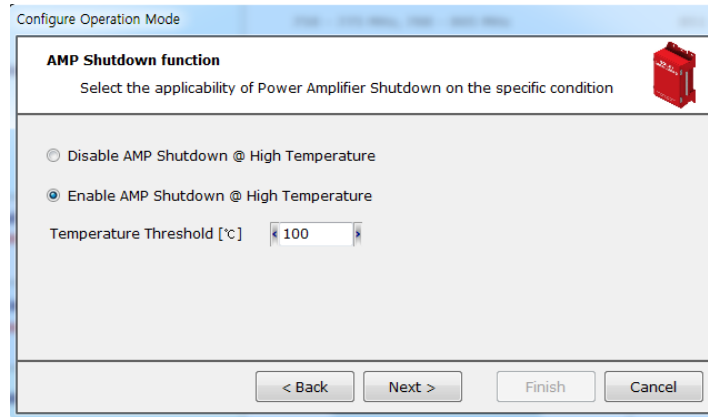

Figure 33. AMP Shutdown Function

4.3.7 Summary

At the last stage, you can check all the information of the modes you selected. When you click the **Finish** button, those selected modes will be applied to the Responder.

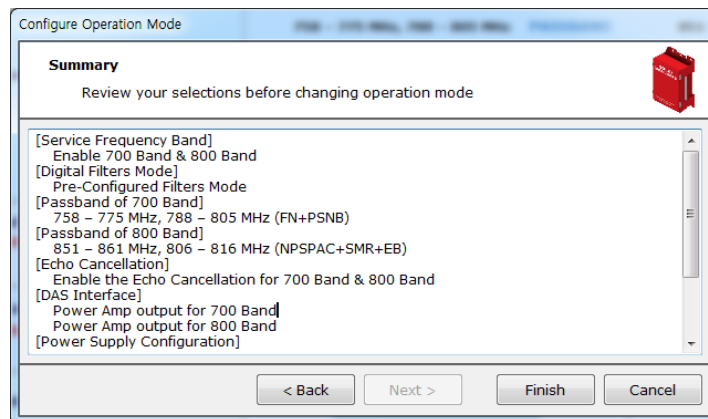

Figure 34. Summary of Selecting the Operation Modes

4.4 Setup Channel Configuration & RF parameters

4.4.1 Input the information of service channels

Service Channels are the channels which is used for the public safety purpose in the specific region. These channels should be passed and amplified in the equipment. And it is, of course, essential for the channel filters. All the information about the service channels can be imported and be exported with the csv file. Below is the window for the importing the service channels.

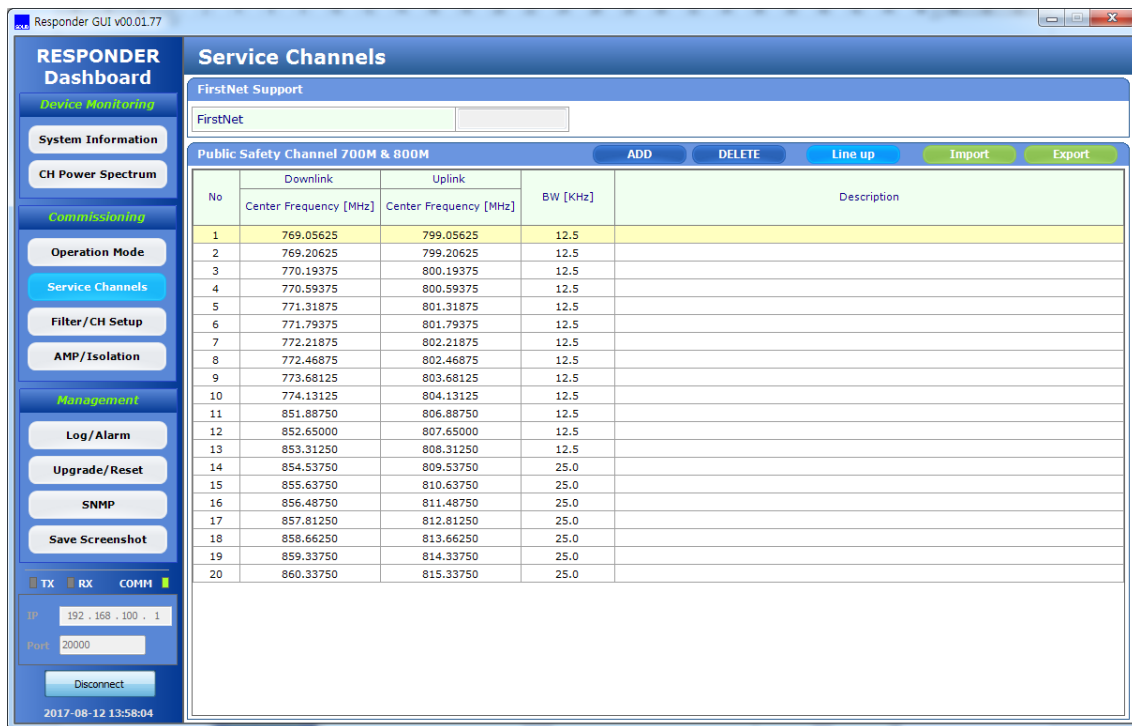

Figure 35. Service Channels Window

4.4.2 Setup Parameters of Digital Filter

4.4.2.1 Pre-Configured Filter Mode

When you select Pre-Configured Filter mode from the Operation Mode, three band-configuration will be displayed as shown below. In this mode, users can control ON/OFF feature of each band and adjust attenuation values up to 10dB. In the **System setting** on the bottom, users can set the maximum gain and maximum output power of the system. The equipment will not exceed these level.

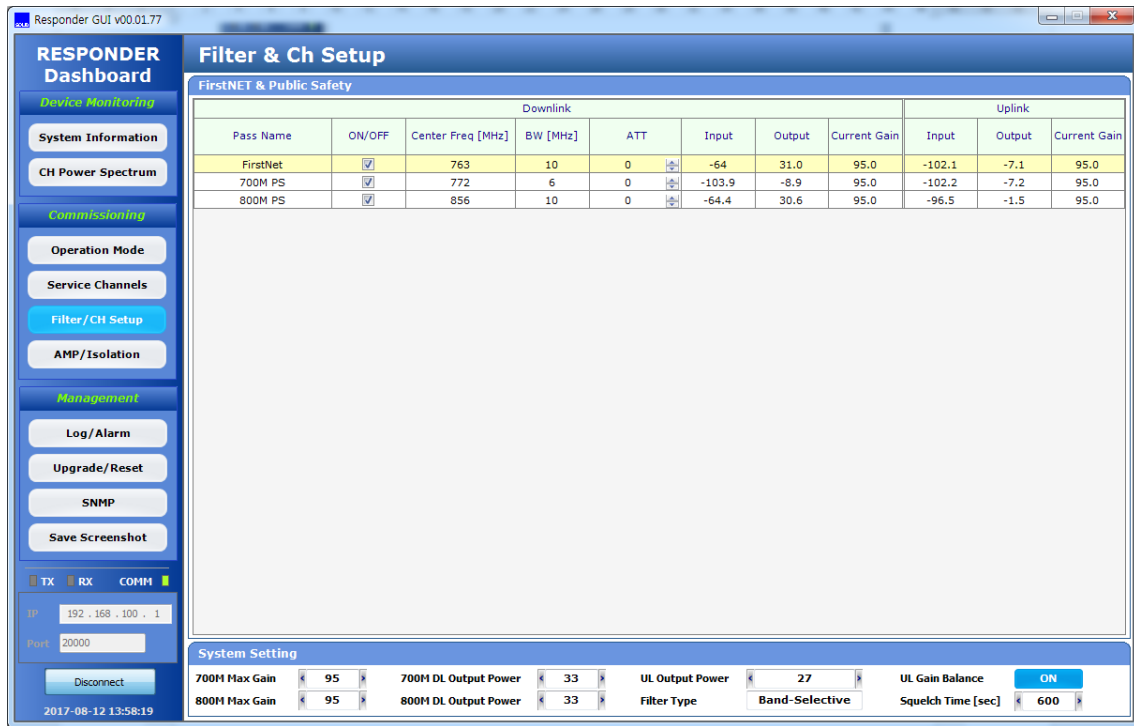

Figure 36. Pre-Configured Filter Mode Window

Table 16. Pre-configured Filter Parameters

Item	Range	Description
700M Max Gain	65 – 95 dB	Set the maximum gain of 700M
800M Max Gain	65 – 95 dB	Set the maximum gain of 800M
700M DL Output Power	3 – 33 dBm	Set the maximum output of 700M DL
800M DL Output Power	3 – 33 dBm	Set the maximum output power of 800M DL
UL Output Power	0 – 27 dBm	Set the maximum output power of UL
Filter Type	Band/Channel	only displayed
UL Gain Balance	On/Off	UL gain has the same value with DL gain As a default, gain balance is on.
Squelch Time	1 – 3600 sec	Dwell time to detect the Squelch

4.4.2.2 36 Channelized Filters

In the 36 Channelized Filter Mode, users can set the total 36 channel-filters across 700M and 800M bands. Users can **Export** and **Import** the information about the current filter.

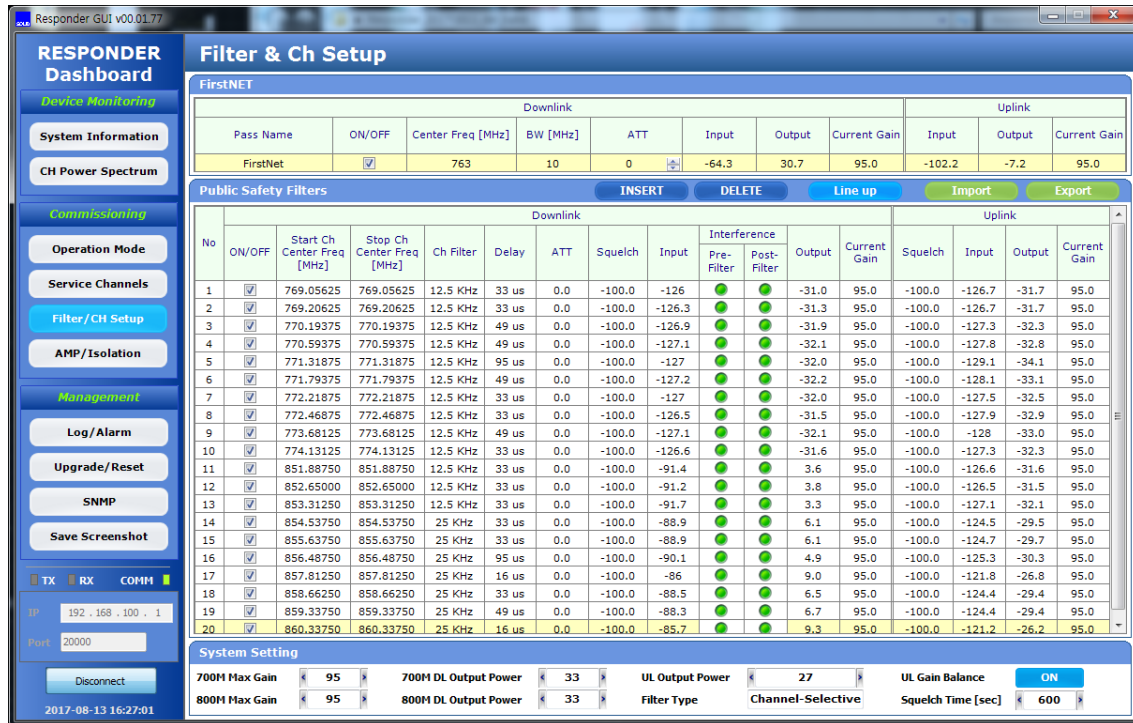

Figure 37. Channelized Filter Mode Window

Public Safety Filters for the narrowband include the following information.

Table 17. 36 Channelized Filter Parameters

Item		Description
DL	Start CH Center Freq.	The lowest channel freq. of the passband
	Stop CH Center Freq.	The highest channel freq. of the passband
	CH Filter	Bandwidth of filter
	Delay	Group Delay of filter
	ATT	Attenuation value
	Squelch	Squelch level
	Input	Input power
	Interference	Pre filter: Interference status before a CH filter Post Filter: Interference status after a CH filter

	Output	Output power
	Current Gain	Current gain
UL	Squelch	Squelch level
	Input	Input power
	Output	Output power
	Current Gain	Current gain

The color of circles in the **Interference** column indicates the relative strength with the channel power. This state is not real-time, but is updated every 2 minutes.

4.5 Isolation Measurement & Tune-up

4.5.1 Monitor Downlink Input Power

Observe downlink input power from the GUI. To receive the input signal with high signal-to-noise ratio is essential to maintain the service with better condition. Align the direction of donor antenna until the DL input power reading is maximized.

4.5.2 Measure the isolation between donor antenna and service antenna

SOLiD Responder has the powerful algorithm to measure antenna isolation which doesn't interfere with radio service. After finishing the basic connection with both antennas, user just enable the amplifier and wait for the result for a moment.

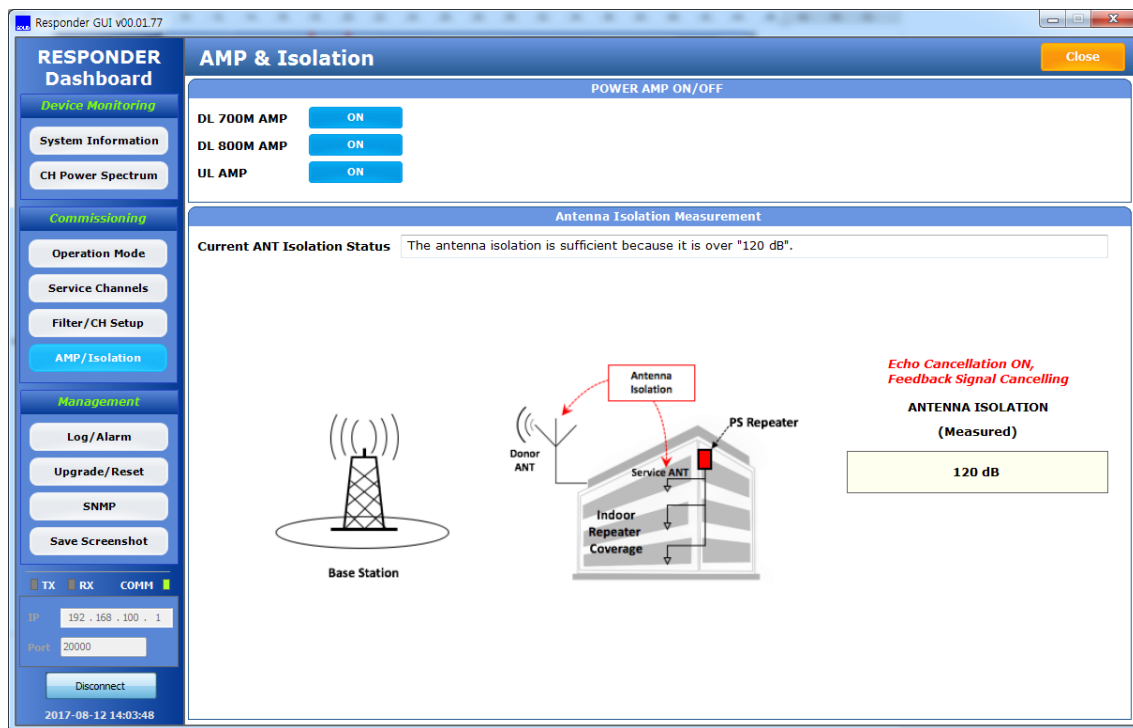

Figure 38. Isolation Measurement Window

4.5.3 Evaluate isolation value & reconfigure the antenna installation

BDA oscillation is caused by low isolation (antenna separation) between donor antenna and service antennas. The recommended isolation between those antennas is 20 dB above the system gain. The amount of isolation that can be achieved between antennas depends on several factors, such as the physical vertical and horizontal separation (distance between the antennas), polarization, radiation pattern of the antennas, the medium between the antennas, antenna gain etc. Considering the above several conditions, evaluate the antenna isolation if it is adequate to cover.

4.5.4 Test coverage area

Use test-equipment to verify field intensity within the coverage area. If needed, realign the service antenna to achieve the desired coverage.

Note that the equipment gain could not be set to maximum or the output power is not high enough due to insufficient donor and service antennas isolation, then the antennas' position should be changed to increase isolation.

4.5.5 Verify UL gain and Performs test calls

Typically, the UL gain is set around 5dB less than DL gain. Users can calculate and determine if the repeater UL noise will interfere with the BTS. Perform test calls in the coverage area to evaluate voice quality.

4.6 SNMP traps & Time Settings

The Responder can notify the remote server about the external alarm output through SNMP (Simple Network Management Protocol) Traps. To use this feature, fill the parameters about network and SNMP traps in the ① section as shown below.

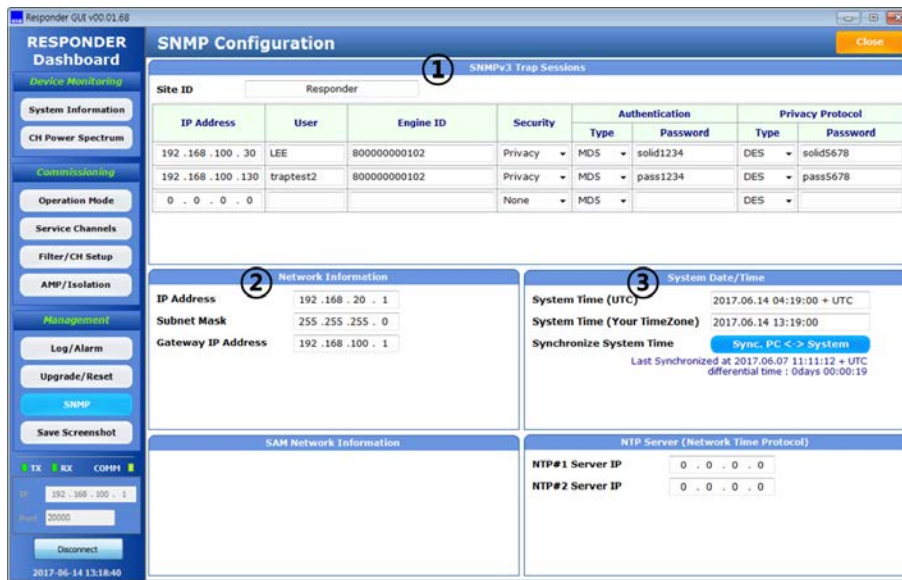

Figure 39. SNMP Configuration

The Responder has another port that can be connected to the external network as well as a port for GUI. You should fill the appropriate network parameters in the ② section to connect the Responder to the internet.

The Responder has Real Time Clock(RTC) inside and uses Universal Time Coordinated (UTC). Users can synchronize Responder’s time with the time of GUI in the PC by clicking Sync.PC ↔ System button in the ③ section. Network Time Protocol (NTP) is a networking protocol for clock synchronization between computer systems over packet-switched, variable-latency data networks.If you change the time in the ③ section, the time for the alarm message also changes.

Table 18. Parameters of Time Setting

Item	Description
System Time (UTC)	It is the UTC time that the Responder has set as the absolute time.
System Time (Your Time zone)	Local time: If you connect your computer with the Responder, the System Time on the GUI will display the time of your computer.
Sync. PC <-> System	It synchronizes the time of the Responder with currently connected computer.
NTP#1 & 2 Server IP	Time synchronization can be done and controlled automatically when the Responder is connected with the external network. To use this feature, enter the IP address of NTP server that will be connected.

5 Administrations

5.1 Viewing General Information

Since the passband's ranges of SOLiD RESPONDER are 12.5 – 200 KHz, FCC part 90 Class A or B device is possible in this mode. If all the passbands are no wider than 75 KHz, the equipment will be Class A device. Otherwise it is Class B device. User can also check FCC part 90 Class from the **System Information** window.

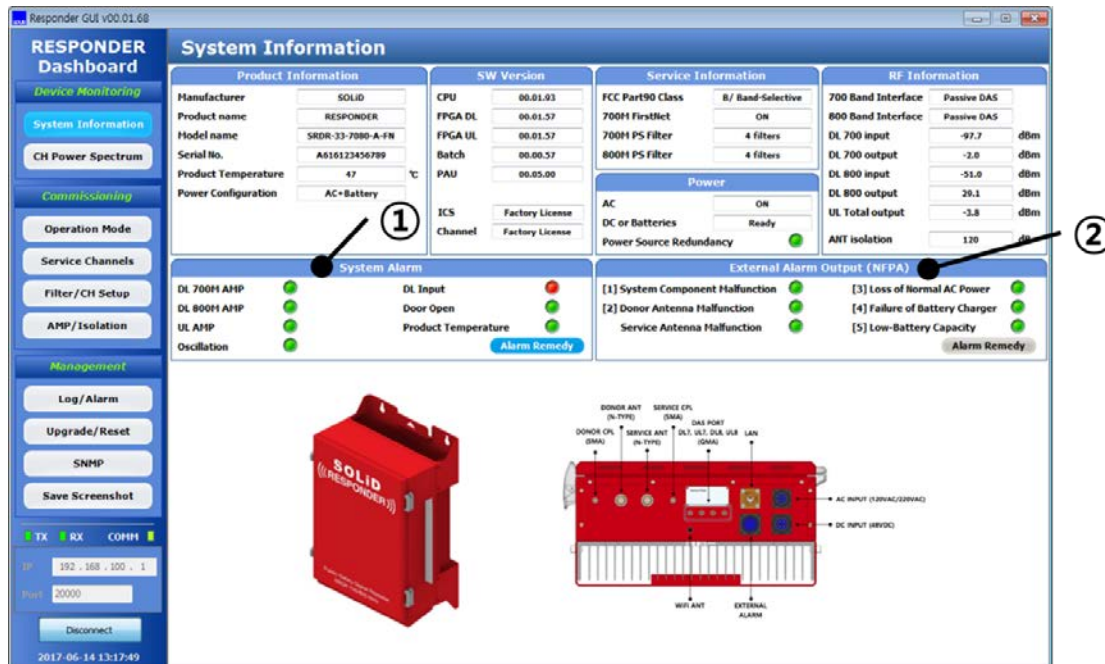

Figure 40. System Information Window

Table 19. Description of System Information

Item	Description
Product Information	
Manufacturer	SOLiD
Product Name	RESPONDER
Model Name	Model information, SRDR-33-7080-A-FN
Serial No.	Serial number of the Responder
Product Temperature	The temperature on the bottom side of the Responder
Power Configuration	Status of power supply
Software Version	
CPU	Information regarding software versions
FPGA DL, FPGA UL	

Batch, PAU	
ICS, Channel	Information whether a user has the license or not
Service Information	
FCC Part 90 Class	B/Band-Selective A/Channel-Selective
700M FirstNet	Filter information that is in service
700M PS Filter	
800M PS Filter	
Power	
AC	Status of power supply
DC or Battery	
RF Information	
700 Band Interface	Output port to the service antenna
800 Band Interface	Active DAS or Passive DAS
DL 700 Input	DL 700M input power
DL 700 Output	DL 700M output power
DL 800 Input	DL 800M input power
DL 800 Output	DL 800M output power
UL Total Output	UL 700M/800M composite output power
ANT Isolation	Antenna isolation information

5.2 Alarm Remedy

Below is the table that describes the meaning and the condition of alarms.

Table 20. Description of Alarms

Alarm Item	Description	Dwell Time to issue	Dwell Time to Clear
① System Alarm			
DL 700M AMP	ON or OFF status of each AMP	Immediately	Immediately
DL 800M AMP		Immediately	Immediately
UL AMP		Immediately	Immediately
Oscillation	If oscillation occurs continuously, the alarm occurs.	Continuous oscillations occur	Otherwise
DL Input	If downlink input power is low, the alarm occurs.	5 seconds	5 seconds
Door Open	When the door opened, the alarm occurs.	Immediately	Immediately
Product Temperature	If the temperature of bottom side is higher than the threshold level, the alarm occurs.	5 seconds	5 seconds

② External Alarm Output (NFPA)			
Power Source Redundancy	If DC power switch is off for the case of AC and batteries, the alarm occurs.	5 seconds	5 seconds
System Component Malfunction	It monitors the device whether it is normal. (If it detects an abnormality, the alarm occurs.)	1 minute	1 minute
Donor Antenna Malfunction	It monitors VSWR status at the port of the device.	5 minutes	1 minute
Service Antenna Malfunction	(If there is failure or no antenna, the alarm occurs.)	5 minutes	1 minute
Loss of Normal AC Power	If there is no AC power, the alarm occurs.	1 minute	1 minute
Failure of Battery Charger	If there is battery charger failure, the alarm occurs.	1 minute	1 minute
Low-Battery Capacity	If the battery power is below 70%, the alarm occurs.	1 minute	1 minute

- ✘ Dwell time to issue: the duration for issuing an alarm
- ✘ Dwell time to clear: the duration for clearing an alarm

When an alarm occurs, the Alarm Remedy button is blinking in green. When you click the Alarm Remedy button, you can see the detailed information about the alarm.

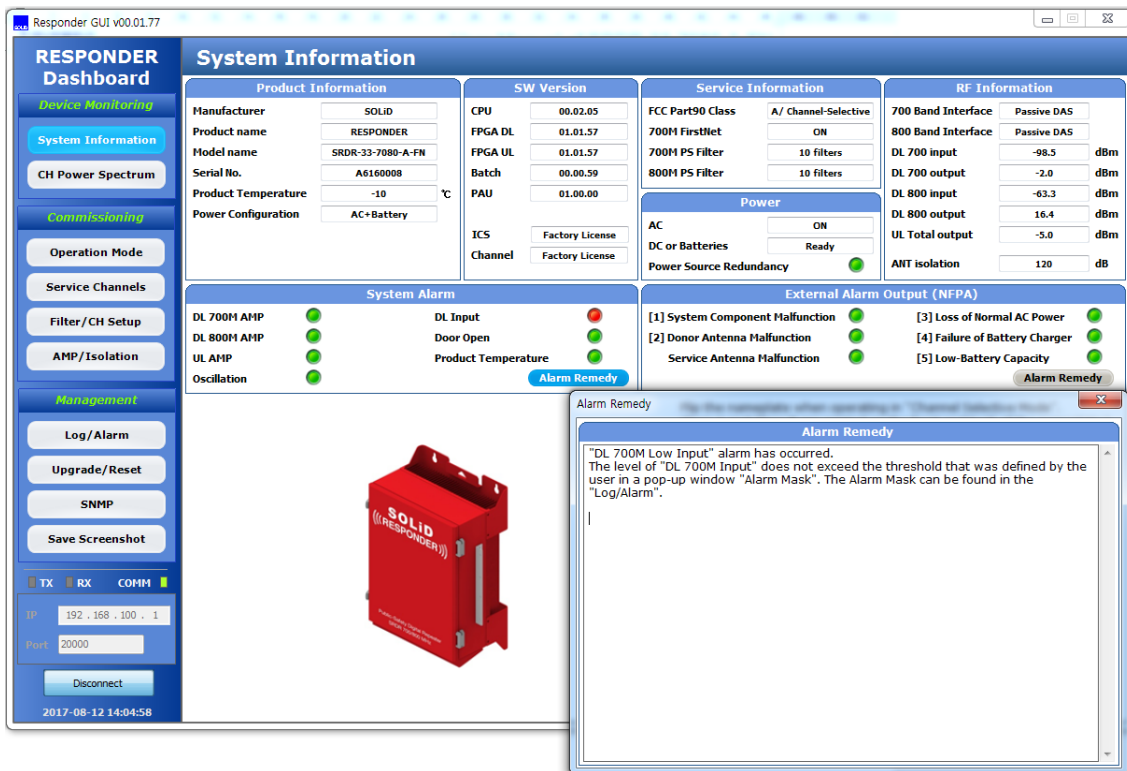

Figure 41. Example of Alarm Remedy

5.3 Alarm Log

5.3.1 Alarm History

No.	Date	Alarm Message
1	2017.06.19 21:15:56	Door Open
2	2017.06.19 21:15:54	[USER] System SW Reset
3	2017.06.19 21:13:22	[EVENT] FPGA Image has been Upgraded (Channel DL)
4	2017.06.19 21:13:22	[EVENT] Batch File has been Upgraded
5	2017.06.19 20:00:05	Door Open
6	2017.06.19 19:36:13	System component malfunction Clear(Power AMP OFF)
7	2017.06.19 19:35:27	Power Config Clear(PSU DC Switch Config)
8	2017.06.19 19:35:24	Door Close
9	2017.06.19 19:35:21	Door Open
10	2017.06.19 19:35:13	DL 700M Power AMP ON(USER Control)
11	2017.06.19 19:35:13	DL 800M Power AMP ON(USER Control)
12	2017.06.19 19:35:13	UL Power AMP ON(USER Control)
13	2017.06.19 19:35:07	DL 700M Input Clear(Low Input)
14	2017.06.19 19:35:07	DL 800M Input Clear(Low Input)
15	2017.06.19 19:35:06	Door Close
16	2017.06.19 19:18:12	System component malfunction(Power AMP OFF)
17	2017.06.19 19:17:21	DL 700M Input(Low Input)
18	2017.06.19 19:17:20	DL 800M Input(Low Input)
19	2017.06.19 19:17:17	Power Config(PSU DC Switch Config)
20	2017.06.19 19:17:13	DL 700M Power AMP OFF(USER Control)
21	2017.06.19 19:17:13	Door Open
22	2017.06.19 19:17:13	UL Power AMP OFF(USER Control)
23	2017.06.19 19:17:13	DL 800M Power AMP OFF(USER Control)
24	2017.06.19 19:17:12	[EVENT] System Power ON
25	2017.06.19 19:14:41	Power Source Redundancy Clear(ac power recovery)
26	2017.06.19 19:14:38	Door Open

Figure 42. System Log

From the above system log, alarms in red mean alarms issued, and alarms in blue mean alarms cleared. Messages in black mean the user's actions. The Responder can store up to 400 logs. When a user wants to save alarms logs, click **Export** button to save them as files. When a user wants to delete all the logs from the Responder, click **Erase** button in the bottom.

5.3.2 Alarm Mask / Shutdown

Click **Alarm Mask / Shutdown** button to check or change parameters of alarms as shown below.

The screenshot shows a software interface titled 'Configuration of Alarms' with a sub-header 'Alarm Mask / Shutdown' and a 'Close' button. It contains two tables: 'Device Alarm' and 'External Alarm'. The 'Device Alarm' table has columns for No, Alarm, Threshold, Unit, Mask, and Shutdown. The 'External Alarm' table has columns for No, Alarm, Mask, and Shutdown. Each row in both tables includes a checkbox for the 'Mask' column and a checkbox for the 'Shutdown' column.

Device Alarm					
No	Alarm	Threshold	Unit	Mask	Shutdown
1	DL 700M AMP User Control			<input type="checkbox"/>	
2	DL 800M AMP User Control			<input type="checkbox"/>	
3	UL AMP User Control			<input type="checkbox"/>	
4	High Temperature	90	°C	<input type="checkbox"/>	
5	Low Temperature	-30	°C	<input type="checkbox"/>	
6	DL 700M Low Input	-95.0	dBm	<input type="checkbox"/>	
7	DL 800M Low Input	-95.0	dBm	<input type="checkbox"/>	
8	DL 700M High Input	-2.0	dBm	<input type="checkbox"/>	<input type="checkbox"/>
9	DL 800M High Input	-2.0	dBm	<input type="checkbox"/>	<input type="checkbox"/>
10	DL 700M High Output	36.0	dBm	<input type="checkbox"/>	<input type="checkbox"/>
11	DL 800M High Output	36.0	dBm	<input type="checkbox"/>	<input type="checkbox"/>
12	UL High Output	33.0	dBm	<input type="checkbox"/>	<input type="checkbox"/>
13	Door Open			<input type="checkbox"/>	
14	Oscillation			<input type="checkbox"/>	

External Alarm			
No	Alarm	Mask	Shutdown
1	System Component Malfunction	<input type="checkbox"/>	
2	Antenna Malfunction	<input type="checkbox"/>	
3	Loss of Normal AC Power	<input type="checkbox"/>	
4	Battery Charger Failure	<input type="checkbox"/>	
5	Low Battery Capacity	<input type="checkbox"/>	

Figure 43. Alarm Mask / Shutdown

Table 21. Description of Terms in the Alarm Mask

Item	Description
Threshold	If it exceeds the threshold value, the alarm occurs.
Mask	Display and change the masking of alarms
Shutdown	ON/OFF feature of each condition for Power AMP Auto Shutdown

5.4 Firmware Upgrade

It allows users to update firmware or to reset the system.

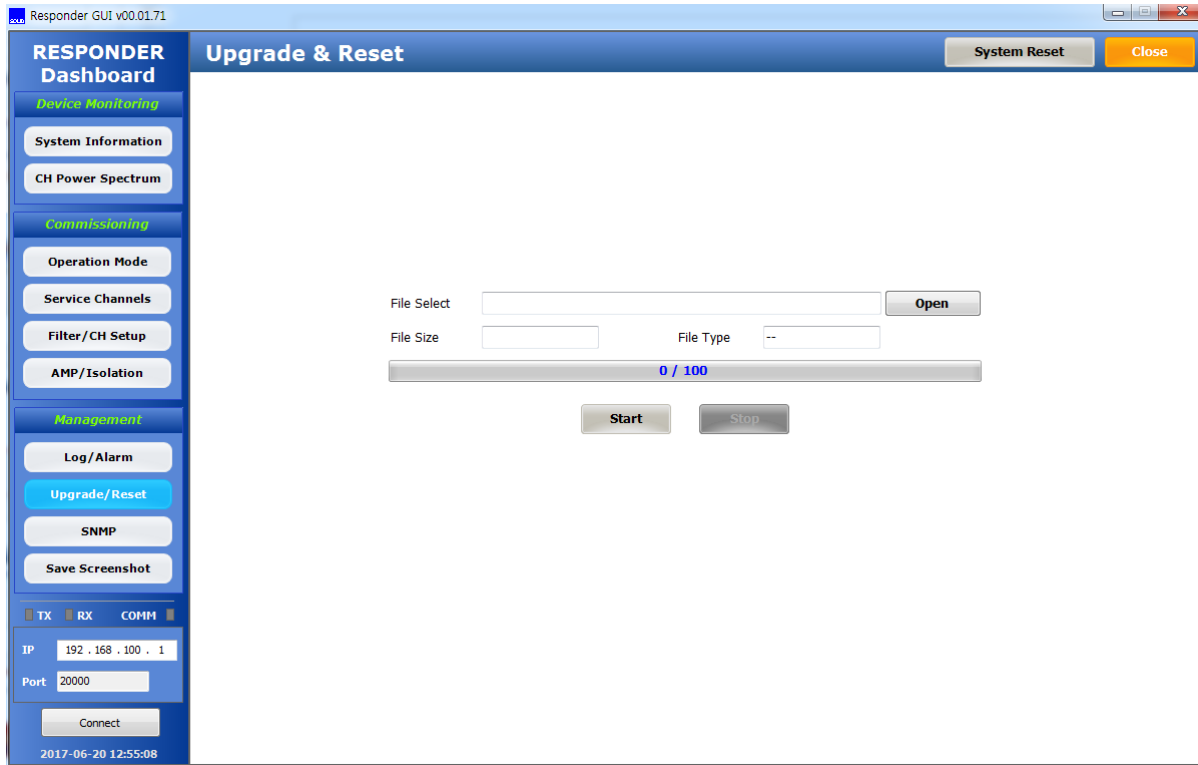

Figure 44. Upgrade / Reset

6 Appendix

6.1 Environmental Specification

Item	Value	Comments
Operating Temperature	-30 - 60°C	
Cooling	Convection	No fan inside
Humidity	10 % - 90% condensed	
Enclosure	IP66, NEMA 4	
Installation site	Indoor & Outdoor	

Item	Value	Comments
Compliance	FCC	
	UL	
	NFPA/IFC	

6.2 Radio Frequency Specification

Item		Value		Comments
		Downlink	Uplink	
Frequency Range		758 – 775 MHz 851 – 861 MHz	788 – 805 MHz 806 – 816 MHz	
Composite Output Power	700 PS	+33 dBm (2W)	+30 dBm (1W)	
	800 PS	+33 dBm (2W)	composite	
Passband Gain		65 – 95 dB	65 – 95 dB	Adjustable with 1dB steps
Passband Ripple		±2.5 dB	±2.5 dB	
Spurious emission		-13 dBm	-13 dBm	
Noise Figure		6 dB	6 dB	
Group Delay		4.5 – 99 usec	4.5 – 99 usec	Depends on types of filters
Maximum RF Input Power with no damage		+ 10 dBm	+ 10 dBm	
Squelch		-110 – -60 dBm		Per channel for UL & DL Adjustable with 1dB steps

6.3 Digital Filter Specification

6.3.1 Public Safety 700 MHz Band–Selective (Class B)

Item		Band-Selective		Comments
		Downlink	Uplink	
Pre-configured	Frequency Range	① 758 – 775 MHz ② 769 – 775 MHz ③ 758 – 768 MHz	① 788 – 805 MHz ② 799 – 805 MHz ③ 788 – 798 MHz	① PS NB + FirstNet (M71) ② PS NB only (M72) ③ FirstNet only (M73)
	Delay	4.5 us for 758 – 768/ 799 – 805 MHz		
		6 us for 769 – 775 / 788 – 805 MHz		
Variable Gain Range		0 – 10 dB with 1dB Step (attenuation only)		For DL & UL
Squelch		Adjustable with 1 dB steps for -110 – -60 dBm		For DL & UL

6.3.2 Public Safety 800 MHz Band –Selective (Class B)

Item		Band-Selective		Comments
		Downlink	Uplink	
Pre-configured	Frequency Range	① 851 – 861 MHz ② 851 – 860 MHz ③ 851 – 854 MHz	① 806 – 816 MHz ② 806 – 815 MHz ③ 806 – 809 MHz	① NSPSPAC, SMR, EB (M81) ② NSPSPAC, SMR (M82) ③ NSPSPAC (M83)
	Delay	5.5 us		60dB @ 1 MHz offset
Variable Gain Range		0 – 10 dB with 1dB Steps (attenuation only)		For DL & UL
Squelch		Adjustable with 1 dB steps for -110 – -60 dBm		For DL & UL

6.3.3 Public Safety 700 & 800 MHz Channel-Selective (Class A)

Item		Channel Selective		Comments
		Downlink	Uplink	
Semi-auto & Manual	BW of Channel Filter	12.5, 25 KHz		
	Number of Channel Filter	36		any increment can be assigned between 700 & 800 bands
	Delay	15 us	15 us	50dB @ 110KHz offset
		33 us	33 us	50dB @ 30KHz offset
		50 us	50 us	50dB @ 20KHz offset
99 us		99 us	50dB @ 10KHz offset	
Variable Gain Range		0 – 10 dB with 1dB Step (attenuation only)		Per Channel For DL & UL
Squelch		Adjustable with 1 dB steps for -110 – -60 dBm		Per Channel For DL & UL

6.4 Power Supply Specification

Item		Value	Comments
Power Supply	AC	100 - 120 VAC	
	DC	48 – 56 VDC	
	Charger	48V-rail charger for lead-acid batteries with State of Charge detection	Up to 1.7A

Operation Mode		Power Consumption		
		120 AC	48 VDC	Power-Saving Mode
<ul style="list-style-type: none"> • 60°C • Non-charge state 	Passive DAS (PS 700 & PS 800)	< 165W	< 150W	< 130W
	Passive DAS (PS 700 or PS 800)	< 140 W	< 125 W	< 110 W
	Active DAS Mode (PS 700 & PS 800)	< 110 W	< 95 W	< 88 W

6.5 Mechanical Specification

Item	Value	Comments
Dimensions (HxWxD)	530 x 420 x 208 (mm) 20.9 x 16.5 x 8.2 (inches)	Without bump
	630 x 460 x 220 (mm) 24.8 x 18.1 x 9.1 (inches)	With bump
Volume	12.5 gal	Without bump
Weight	34kg, 75 lb	
19" Rack Mount	Yes	
Power Port		
AC Power	MS3102 16-10S (3pin)	
DC Power	MS3102 18-10S (2pin)	
Antenna Port		
Donor	N-Female	
Donor Coupling	SMA-Female	30 dB coupled to antenna port
Service	N-Female	
Service Coupling	SMA-Female	30 dB coupled to antenna port
Active DAS Port		
700 DL	QMA, Female	-5dBm @ maximum
800 DL	QMA, Female	-5dBm @ maximum
700 UL	QMA, Female	
800 UL	QMA, Female	
Communications Port		
Antenna Port – WiFi	SMA, Female	Local management terminal
Ethernet Port	RJ-45 port with IP66	SNMP traps
Relay Output	MS3102 20-29S (17 pin)	5 Relay outputs ① System component malfunction. ② VSWR-antenna malfunction ③ Normal AC power, Loss of normal AC power

		<ul style="list-style-type: none">④ Battery charger failure⑤ Low battery capacity (to 70 percent depletion)
--	--	--

– End of the document –