

# FCC REPORT

## Certification

**Applicant Name:**

SOLiD, Inc.

**Date of Issue:**

March 20, 2019

**Address:**

10, 9th Floor, SOLiD Space, Pangyoyeok-ro  
220, Bundang-gu, Seongnam-si, Gyeonggi-do, 463-400,  
South Korea

**Location:**

HCT CO., LTD.,  
74, Seoicheon-ro 578beon-gil, Majang-myeon,  
Icheon-si, Gyeonggi-do, 17383, Rep. of KOREA

**Report No.:** HCT-RF-1903-FC001-R2

**FCC ID:** W6UGDL7819212325

**APPLICANT:** SOLiD, Inc.

**Model:** LRN

**EUT Type:** DAS

**Frequency Range:**

Band Name	Downlink (MHz)	Output Power(dBm)
Lower 700 MHz	729 ~ 746	15
Upper 700 MHz	746 ~ 758	15
PS Broadband	758 ~ 768	15
ESMR	862 ~ 869	15
Cellular	869 ~ 894	15
Broadband PCS	1 930 ~ 1 995	20
AWS1+3	2 110 ~ 2 180	20
WCS	2 350 ~ 2 360	17
BRS/EBS	2 497.4 ~ 2 687.4	20

**Date of Test:** January 17, 2019 ~ March 20, 2019

**FCC Rule Parts:** CFR 47 Part 2, Part 22, Part 24, Part 27, Part 90

The measurements shown in this report were made in accordance with the procedures indicated, and the emissions from this equipment were found to be within the limits applicable. I assume full responsibility for the accuracy and completeness of these measurements, and for the qualifications of all persons taking them. It is further stated that upon the basis of the measurements made, the equipment tested is capable of operation in accordance with the requirements of the FCC Rules under normal use and maintenance.



**Report prepared by : Kyung Soo Kang**  
**Engineer of telecommunication testing center**



**Approved by : Kwon Jeong**  
**Manager of telecommunication testing center**

This report only responds to the tested sample and may not be reproduced, except in full, without written approval of the HCT Co., Ltd.

# Version

TEST REPORT NO.	DATE	DESCRIPTION
HCT-RF-1903-FC001	March 07, 2019	- First Approval Report
HCT-RF-1903-FC001-R1	March 15, 2019	- Updated the test equipments in the section 4. - Added the test results and the rule part of the 90.543(e), (f). - Added a note about §90.691(a)(2) in the section 5.5.
HCT-RF-1903-FC001-R2	March 20, 2019	- Revised the test results in section 5.2, 5.3. - Added a note about the measurement bandwidth specified in the applicable rule section for the supported frequency band. (in section 5.5)

# Table of Contents

1. GENERAL INFORMATION.....	4
1.1. APPLICANT INFORMATION.....	4
1.2. PRODUCT INFORMATION .....	4
1.3. TEST INFORMATION .....	4
2. FACILITIES AND ACCREDITATIONS .....	5
2.1. FACILITIES .....	5
2.2. EQUIPMENT .....	5
3. TEST SPECIFICATIONS.....	6
3.1. STANDARDS .....	6
3.2. ADDITIONAL DESCRIPTIONS ABOUT TEST .....	7
3.3. MEASUREMENT UNCERTAINTY .....	10
3.4. STANDARDS ENVIRONMENTAL TEST CONDITIONS .....	10
3.5. TEST DIAGRAMS.....	11
4. TEST EQUIPMENTS.....	12
5. TEST RESULT .....	13
5.1. AGC THRESHOLD .....	13
5.2. OUT-OF-BAND REJECTION.....	15
5.3. INPUT-VERSUS-OUTPUT SIGNAL COMPARISON .....	20
5.4. INPUT/OUTPUT POWER AND AMPLIFIER/BOOSTER GAIN .....	65
5.5. OUT-OF-BAND/OUT-OF-BLOCK EMISSIONS AND SPURIOUS EMISSIONS.....	92
5.6. RADIATED SPURIOUS EMISSIONS .....	557
6. Annex A_EUT AND TEST SETUP PHOTO .....	559

## 1. GENERAL INFORMATION

### 1.1. APPLICANT INFORMATION

Company Name	SOLiD, Inc.
Company Address	10, 9th Floor, SOLiD Space, Pangyoyeok-ro 220, Bundang-gu, Seongnam-si, Gyeonggi-do, 463-400, South Korea

### 1.2. PRODUCT INFORMATION

EUT Type	DAS		
Power Supply	57 VDC from HOU		
Frequency Range / Tx Output Power	Band Name	Downlink (MHz)	Output Power(dBm)
	Lower 700 MHz	729 ~ 746	15
	Upper 700 MHz	746 ~ 758	15
	PS Broadband	758 ~ 768	15
	ESMR	862 ~ 869	15
	Cellular	869 ~ 894	15
	Broadband PCS	1 930 ~ 1 995	20
	AWS1+3	2 110 ~ 2 180	20
	WCS	2 350 ~ 2 360	17
	BRS/EBS	2 497.4 ~ 2 687.4	20
Antenna Specification	Manufacturer does not provide an antenna.		

### 1.3. TEST INFORMATION

FCC Rule Parts	CFR 47 Part 2, Part 22, Part 24, Part 27, Part 90
Measurement Standards	KDB 935210 D05 v01r02, ANSI C63.26-2015
Test Location	HCT CO., LTD. 74, Seoicheon-ro 578beon-gil, Majang-myeon, Icheon-si, Gyeonggi-do, 17383, Rep. of KOREA

## **2. FACILITIES AND ACCREDITATIONS**

### **2.1. FACILITIES**

The SAC(Semi-Anechoic Chamber) and conducted measurement facility used to collect the radiated data are located at the 74, Seoicheon-ro 578beon-gil, Majang-myeon, Icheon-si, Gyeonggi-do, 17383, Rep. of KOREA.

The site is constructed in conformance with the requirements of ANSI C63.4 (Version: 2014) and CISPR Publication 22.

Detailed description of test facility was submitted to the Commission and accepted dated April 02, 2018 (Registration Number: KR0032).

### **2.2. EQUIPMENT**

Radiated emissions are measured with one or more of the following types of linearly polarized antennas: tuned dipole, bi-conical, log periodic, bi-log, and/or ridged waveguide, horn. Spectrum analyzers with pre-selectors and quasi-peak detectors are used to perform radiated measurements.

Calibrated wideband preamplifiers, coaxial cables, and coaxial attenuators are also used for making measurements.

All receiving equipment conforms to CISPR Publication 16-1, "Radio Interference Measuring Apparatus and Measurement Methods."

### 3. TEST SPECIFICATIONS

#### 3.1. STANDARDS

The following tests were conducted on a sample of the equipment for the purpose of demonstrating compliance with FCC Part 2, Part 22, Part 24, Part 27 and Part 90.

Description	Reference	Results
AGC threshold	KDB 935210 D05 v01r02 3.2	Compliant
Out-of-band rejection	KDB 935210 D05 v01r02 3.3	Compliant
Input-versus-output signal comparison	§2.1049	Compliant
Input/output power and amplifier/booster gain	§2.1046, §22.913, §24.232, §27.50(a),(b),(c),(d),(h), §90.219(e)(1), §90.542, §90.635	Compliant
Out-of-band/out-of-block emissions and spurious emissions	§2.1051, §22.917, §24.238, §27.53(a),(c),(f),(g),(h),(m), §90.219(e)(3), §90.543, §90.691	Compliant
Spurious emissions radiated	§2.1053	Compliant

### 3.2. ADDITIONAL DESCRIPTIONS ABOUT TEST

Except for the following cases, EUT was tested under normal operating conditions.

: Out-of-band rejection test requires maximum gain condition without AGC

The test was generally based on the method of KDB 935210 D05 v01r02 and only followed ANSI C63.26-2015 if there was no test method in KDB standard.

EUT was tested with following modulated signals provide by applicant.

Band Name	Tested signals
Lower 700 MHz	LTE 5 MHz, LTE 10 MHz
Upper 700 MHz	LTE 5 MHz, LTE 10 MHz
PS Broadband	LTE 5 MHz, LTE 10 MHz
ESMR	GSM, CDMA, WCDMA
Cellular	GSM, CDMA, WCDMA
Broadband PCS	GSM, CDMA, WCDMA, LTE 5 MHz, LTE 10 MHz, LTE 20 MHz
AWS1+3	LTE 5 MHz, LTE 10 MHz, LTE 20 MHz
WCS	LTE 5 MHz, LTE 10 MHz
BRS/EBS	LTE 5 MHz (TDD), LTE 10 MHz (TDD), LTE 20 MHz (TDD)

The frequency stability measurement has been omitted in accordance with section 3.7 of KDB 935210 D05 v01r02.

: It can be confirmed through input-versus-output signal comparison test that EUT does not alter the input signal.

The tests results included actual loss value for attenuator and cable combination as shown in the table below.

: Input Path

Correction factor table			
Frequency (MHz)	Factor (dB)	Frequency (MHz)	Factor (dB)
500	0.394	1800	0.963
550	0.238	1850	1.093
600	0.287	1900	1.006
650	0.455	1950	0.949
700	0.425	2000	0.966
750	0.473	2050	0.965
800	0.479	2100	0.985
850	0.537	2150	1.058
900	0.536	2200	1.137
950	0.569	2250	1.079
1000	0.457	2300	1.078
1050	0.573	2350	1.085
1100	0.561	2400	1.113
1150	0.664	2450	1.162
1200	0.728	2500	1.151
1250	0.713	2550	1.193
1300	0.669	2600	1.093
1350	0.724	2650	1.127
1400	0.692	2700	1.105
1450	0.712	2750	0.995
1500	0.721	2800	0.977
1550	0.807	2850	1.000
1600	0.931	2900	1.092
1650	0.792	2950	1.183
1700	0.753	3000	1.108
1750	0.841		



: Output Path

Correction factor table			
Frequency (MHz)	Factor (dB)	Frequency (MHz)	Factor (dB)
2	31.060	5000	39.061
10	30.153	5500	38.673
30	29.924	6000	38.669
50	30.021	6500	38.414
100	30.186	7000	37.847
200	30.709	7500	37.864
300	31.003	8000	37.571
400	31.206	8500	36.882
500	31.441	9000	36.807
600	31.548	9500	36.639
700	31.908	10000	37.826
750	32.040	11000	37.216
800	32.127	12000	37.441
850	32.302	13000	36.915
900	32.408	14000	37.354
1000	32.558	15000	37.877
1500	33.993	16000	38.384
1800	34.984	17000	37.809
1900	35.422	18000	38.446
2000	35.743	19000	38.624
2100	36.124	20000	37.418
2200	36.477	21000	37.067
2300	36.858	22000	35.775
2400	37.268	22100	36.070
2500	37.577	23000	38.208
2600	37.890	24000	40.744
2700	38.250	25000	36.665
3000	39.050	26000	40.127
4000	39.902	26500	40.832
4500	39.409		

### 3.3. MEASUREMENT UNCERTAINTY

Description	Reference	Results
AGC threshold	-	±0.87 dB
Out-of-band rejection	-	±0.58 MHz
Input-versus-output signal comparison	OBW > 5 MHz	±0.58 MHz
Input/output power and amplifier/booster gain	-	±0.87 dB
Out-of-band/out-of-block emissions and spurious emissions	-	±1.08 dB
Spurious emissions radiated	f ≤ 1 GHz	±4.80 dB
	f > 1 GHz	±6.07 dB

\* Coverage factor  $k = 2$ , Confidence levels of 95 %

### 3.4. STANDARDS ENVIRONMENTAL TEST CONDITIONS

Temperature	+15 °C to +35 °C
Relative humidity	30 % to 60 %
Air pressure	860 mbar to 1 060 mbar

### 3.5. TEST DIAGRAMS

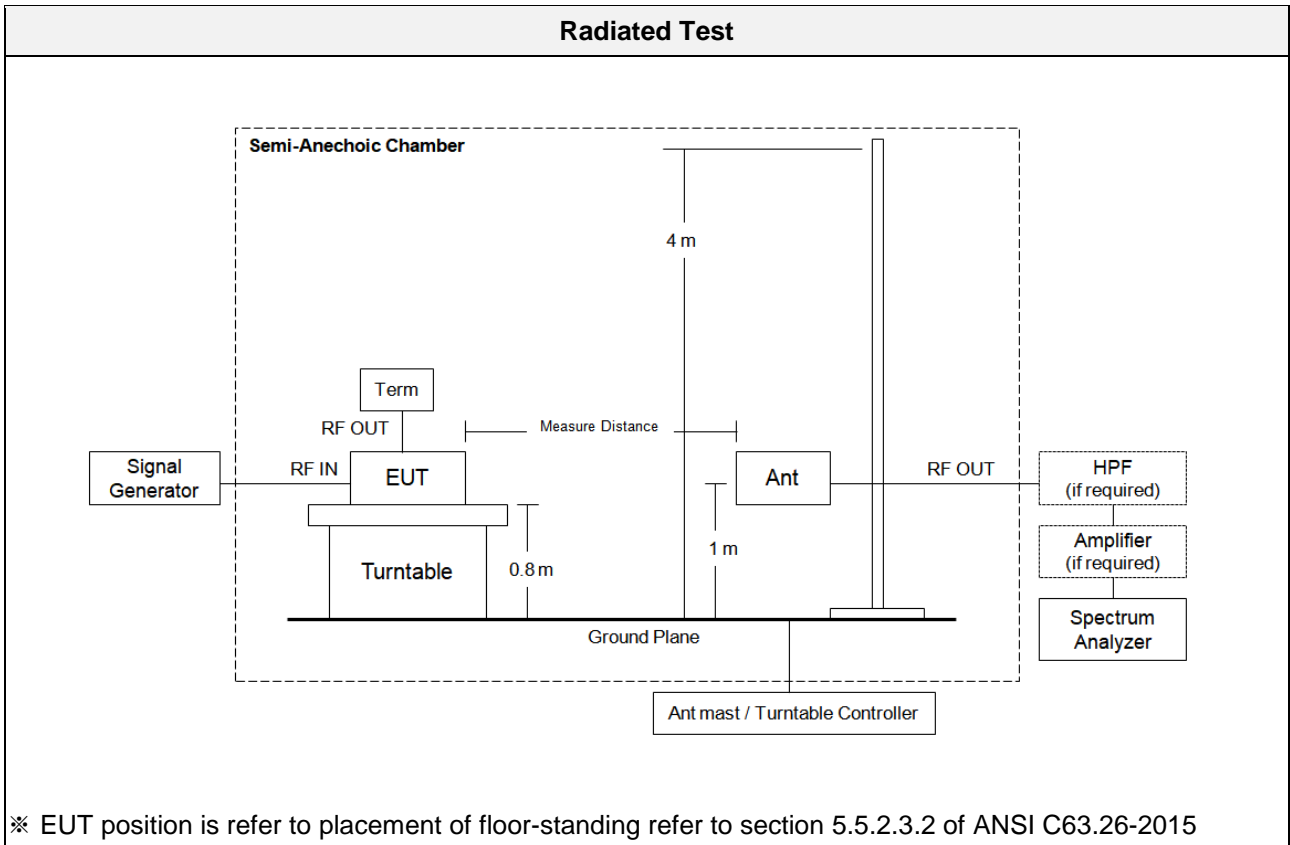
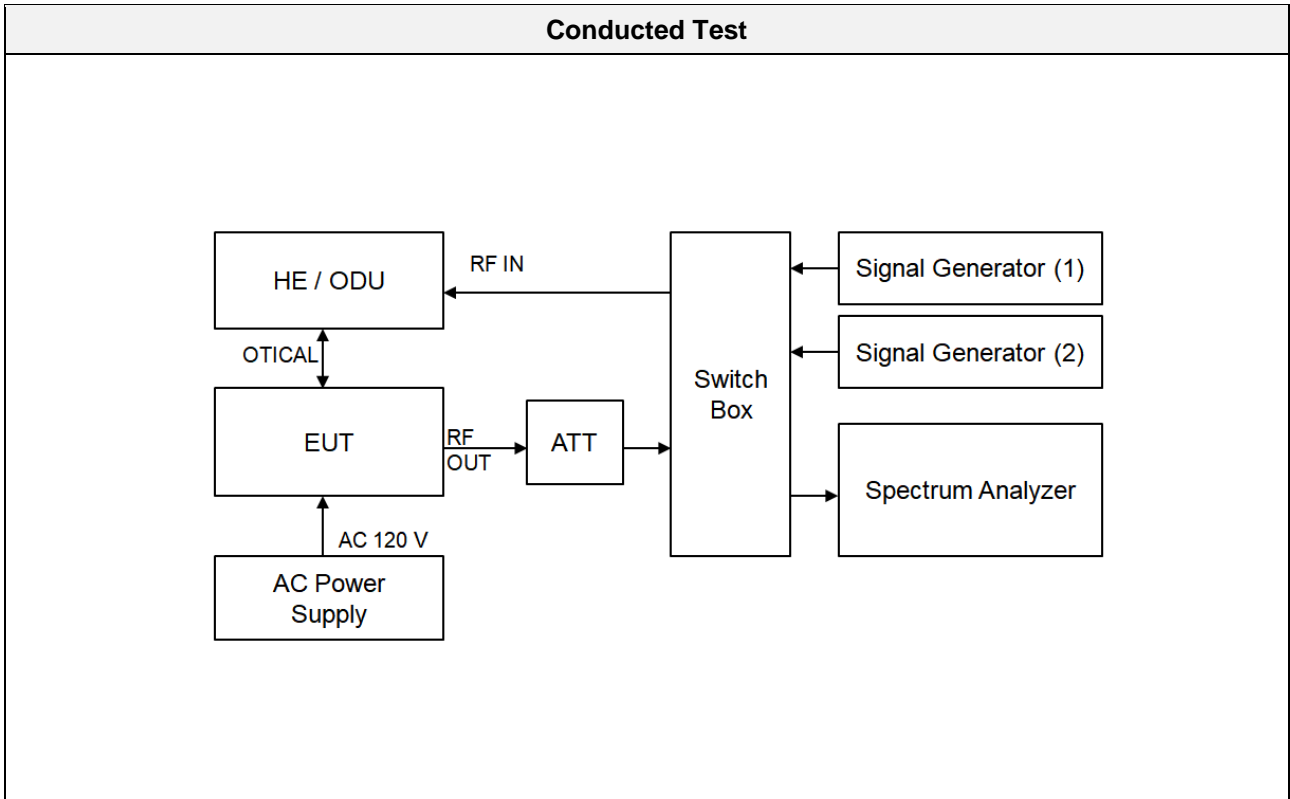

#### 4. TEST EQUIPMENTS

Manufacturer	Model / Equipment	Calibration Date	Calibration Interval	Serial No.
Agilent	N9020A / MXA Signal Analyzer	08/29/2018	Annual	MY52440870
Keysight	N9030B / PXA Signal Analyzer	08/29/2018	Annual	MY55480167
Agilent	N5182A / Signal Generator	03/05/2018	Annual	MY50141649
Agilent	N5182A / Signal Generator	08/09/2018	Annual	MY50140312
Agilent	N5182A / Signal Generator	08/30/2018	Annual	MY50142996
Agilent	8498A / High Power Attenuator	02/19/2018	Annual	51161
KEITHLEY	S46 / Switch	N/A	N/A	1088024
Innco system	CO3000 / Controller(Antenna mast)	N/A	N/A	CO3000-4p
Innco system	MA4640/800-XP-EP / Antenna Position Tower	N/A	N/A	N/A
Emco	2090 / Controller	N/A	N/A	060520
Ets	- / Turn Table	N/A	N/A	N/A
Rohde&Schwarz	- / Loop Antenna	08/23/2018	Biennial	1513-175
Schwarzbeck	VULB 9168 / Hybrid Antenna	04/06/2017	Biennial	760
Schwarzbeck	BBHA 9120D / Horn Antenna	06/30/2017	Biennial	9120D-1300
Schwarzbeck	BBHA9170 / Horn Antenna(15 GHz ~ 40 GHz)	04/25/2017	Biennial	BBHA9170124
Rohde&Schwarz	FSP / Spectrum Analyzer	09/19/2018	Annual	836650/016
Wainwright Instruments	WHKX10-900-1000-15000-40SS / High Pass Filter	07/20/2018	Annual	5
Wainwright Instruments	WHKX10-2700-3000-18000-40SS / High Pass Filter	07/20/2018	Annual	3
CERNEX	CBLU1183540 / Power Amplifier	07/10/2018	Annual	22964
CERNEX	CBL06185030 / Power Amplifier	07/10/2018	Annual	22965
CERNEX	CBL26405040 / Power Amplifier	07/10/2018	Annual	19660

\* The following equipment has been updated due to the revision report.

Agilent	N5182A / Signal Generator	03/06/2019	Annual	MY50141649
Agilent	8498A / High Power Attenuator	02/18/2019	Annual	51161

## 5. TEST RESULT

### 5.1. AGC THRESHOLD

**Test Requirement:**

**KDB 935210 D05 v01r02**

Testing at and above the AGC threshold is required.

**Test Procedures:**

Measurements were in accordance with the test methods section 3.2 of KDB 935210 D05 v01r02.

*In the case of fiber-optic distribution systems, the RF input port of the equipment under test (EUT) refers to the RF input of the supporting equipment RF to optical convertor; see also descriptions and diagrams for typical DAS booster systems in KDB Publication 935210 D02*

*Devices intended to be directly connected to an RF source (donor port) only need to be evaluated for any over-the-air transmit paths.*

- a) Connect a signal generator to the input of the EUT.
- b) Connect a spectrum analyzer or power meter to the output of the EUT using appropriate attenuation as necessary.
- c) The signal generator should initially be configured to produce either of the required test signals (i.e., broadband or narrowband).
- d) Set the signal generator frequency to the center frequency of the EUT operating band.
- e) While monitoring the output power of the EUT, measured using the methods of 3.5.3 or 3.5.4, increase the input level until a 1 dB increase in the input signal power no longer causes a 1 dB increase in the output signal power.
- f) Record this level as the AGC threshold level.
- g) Repeat the procedure with the remaining test signal.

Output power measurement in subclause 5.2.4.4.1 of ANSI C63.26

- a) Set span to  $2 \times$  to  $3 \times$  the OBW.
- b) Set RBW = 1% to 5% of the OBW.
- c) Set VBW  $\geq 3 \times$  RBW.
- d) Set number of measurement points in sweep  $\geq 2 \times$  span / RBW.
- e) Sweep time: auto-couple
- f) Detector = power averaging (rms).
- g) If the EUT can be configured to transmit continuously, then set the trigger to free run.
- h) Omit
- i) Trace average at least 100 traces in power averaging (rms) mode if sweep is set to auto-couple. To

accurately determine the average power over multiple symbols, it can be necessary to increase the number of traces to be averaged above 100 or, if using a manually configured sweep time, increase the sweep time.

j) Compute the power by integrating the spectrum across the OBW of the signal using the instrument's band or channel power measurement function, with the band/channel limits set equal to the OBW band edges. If the instrument does not have a band or channel power function, then sum the spectrum levels (in linear power units) at intervals equal to the RBW extending across the entire OBW of the spectrum.

**Test Results:**

Test Band	Link	Signal	Center Frequency (MHz)	AGC Threshold Level (dBm)	Output Level (dBm)
Lower 700 MHz	Downlink	LTE 5 MHz	737.50	0	15.00
		LTE 10 MHz	737.50	0	15.08
Upper 700 MHz	Downlink	LTE 5 MHz	752.00	0	14.87
		LTE 10 MHz	752.00	0	14.91
PS Broadband	Downlink	LTE 5 MHz	763.00	0	15.02
		LTE 10 MHz	763.00	0	15.00
ESMR	Downlink	GSM	865.50	0	14.94
		CDMA	865.50	0	15.10
		WCDMA	865.50	0	15.24
Cellular	Downlink	GSM	881.50	0	14.71
		CDMA	881.50	0	14.73
		WCDMA	881.50	0	14.69
Broadband PCS	Downlink	GSM	1962.50	0	20.35
		CDMA	1962.50	0	20.63
		WCDMA	1962.50	0	20.49
		LTE 5 MHz	1962.50	0	20.33
		LTE 10 MHz	1962.50	0	20.40
		LTE 20 MHz	1962.50	0	20.24
AWS1+3	Downlink	LTE 5 MHz	2145.00	0	19.59
		LTE 10 MHz	2145.00	0	20.19
		LTE 20 MHz	2145.00	0	19.98
WCS	Downlink	LTE 5 MHz	2355.00	0	17.30
		LTE 10 MHz	2355.00	0	17.04
BRS/EBS	Downlink	LTE 5 MHz (TDD)	2592.40	0	19.07
		LTE 10 MHz (TDD)	2592.40	0	19.67
		LTE 20 MHz (TDD)	2592.40	0	19.43

## 5.2. OUT-OF-BAND REJECTION

### Test Requirement:

#### KDB 935210 D05 v01r02

Out-of-band rejection required.

### Test Procedures:

Measurements were in accordance with the test methods section 3.3 of KDB 935210 D05 v01r02.

*Adjust the internal gain control of the EUT to the maximum gain for which equipment certification is sought.*

- a) Connect a signal generator to the input of the EUT.
- b) Configure a swept CW signal with the following parameters:
  - 1) Frequency range =  $\pm 250\%$  of the passband, for each applicable CMRS band.
  - 2) Level = a sufficient level to affirm that the out-of-band rejection is  $> 20$  dB above the noise floor and will not engage the AGC during the entire sweep.
  - 3) Dwell time = approximately 10 ms.
  - 4) Number of points =  $\text{SPAN}/(\text{RBW}/2)$ .
- c) Connect a spectrum analyzer to the output of the EUT using appropriate attenuation.
- d) Set the span of the spectrum analyzer to the same as the frequency range of the signal generator.
- e) Set the resolution bandwidth (RBW) of the spectrum analyzer to be 1 % to 5 % of the EUT passband, and the video bandwidth (VBW) shall be set to  $\geq 3 \times \text{RBW}$ .
- f) Set the detector to Peak Max-Hold and wait for the spectrum analyzer's spectral display to fill.
- g) Place a marker to the peak of the frequency response and record this frequency as  $f_0$ .
- h) Place two markers, one at the lowest and the other at the highest frequency of the envelope of the spectral display, such that each marker is at or slightly below the  $-20$  dB down amplitude, to determine the 20 dB bandwidth.
- i) Capture the frequency response of the EUT.
- j) Repeat for all frequency bands applicable for use by the EUT.

**Test Results:**

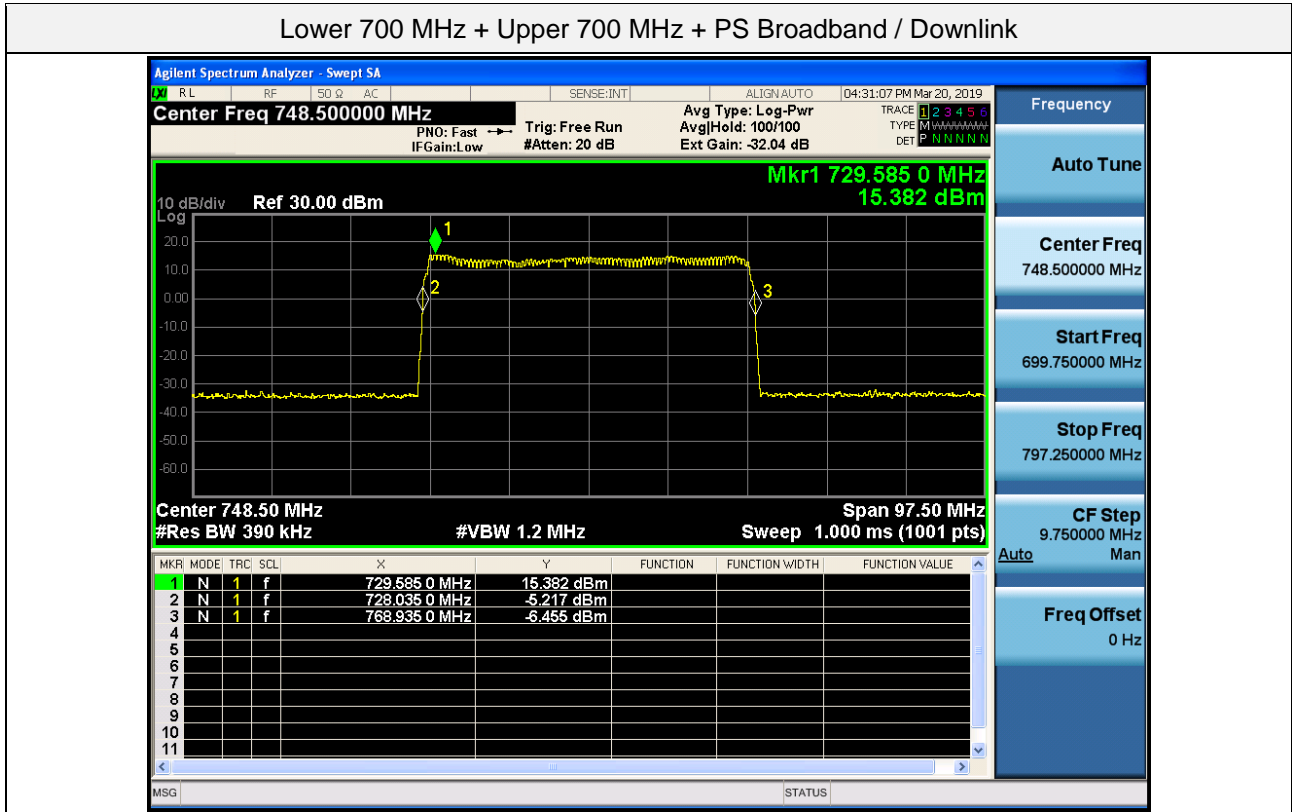

\* 700 MHz module amplifies Lower 700 MHz band (729 ~ 746 MHz), Upper 700 MHz band (746 ~ 758 MHz) and PS Broadband (758 ~ 768 MHz) together.



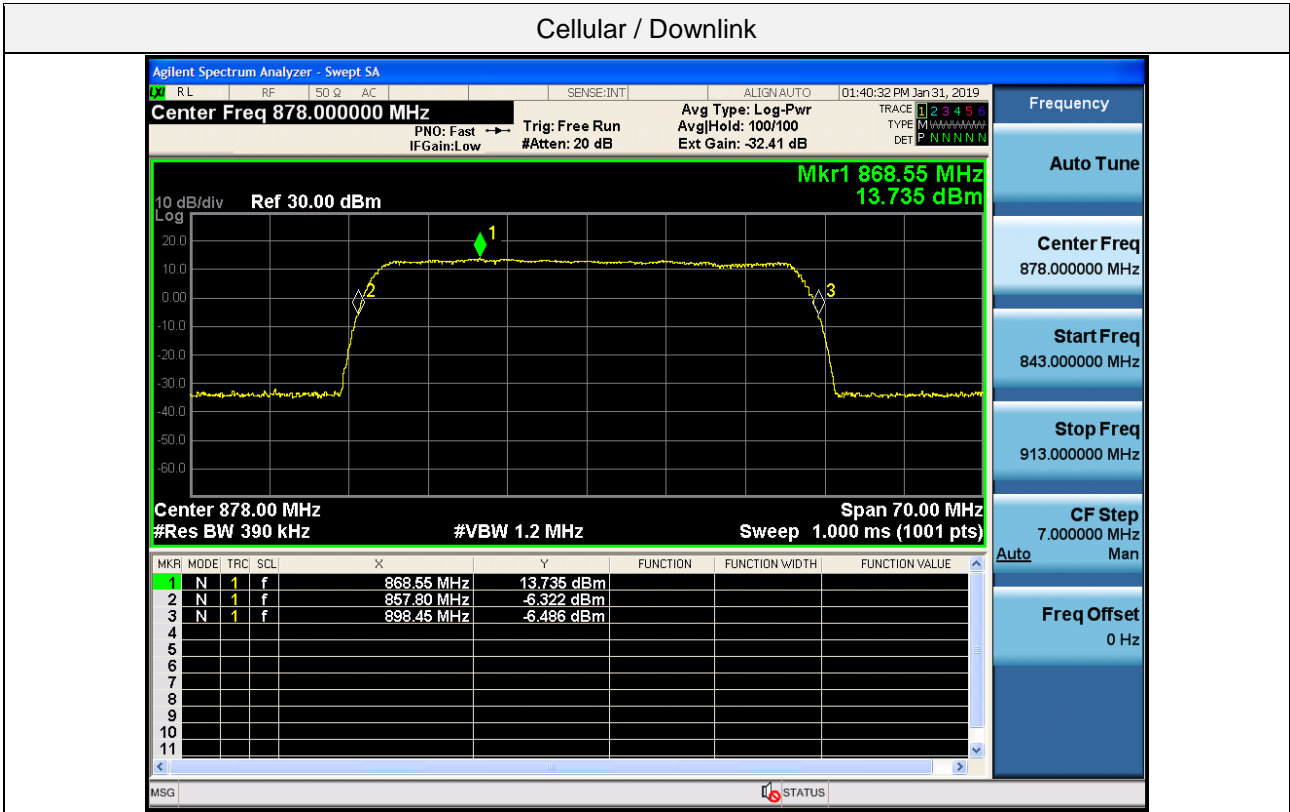

\* 800 MHz module amplifies ESMR (862 ~ 869 MHz), and Cellular band(869 ~ 894 MHz) together.

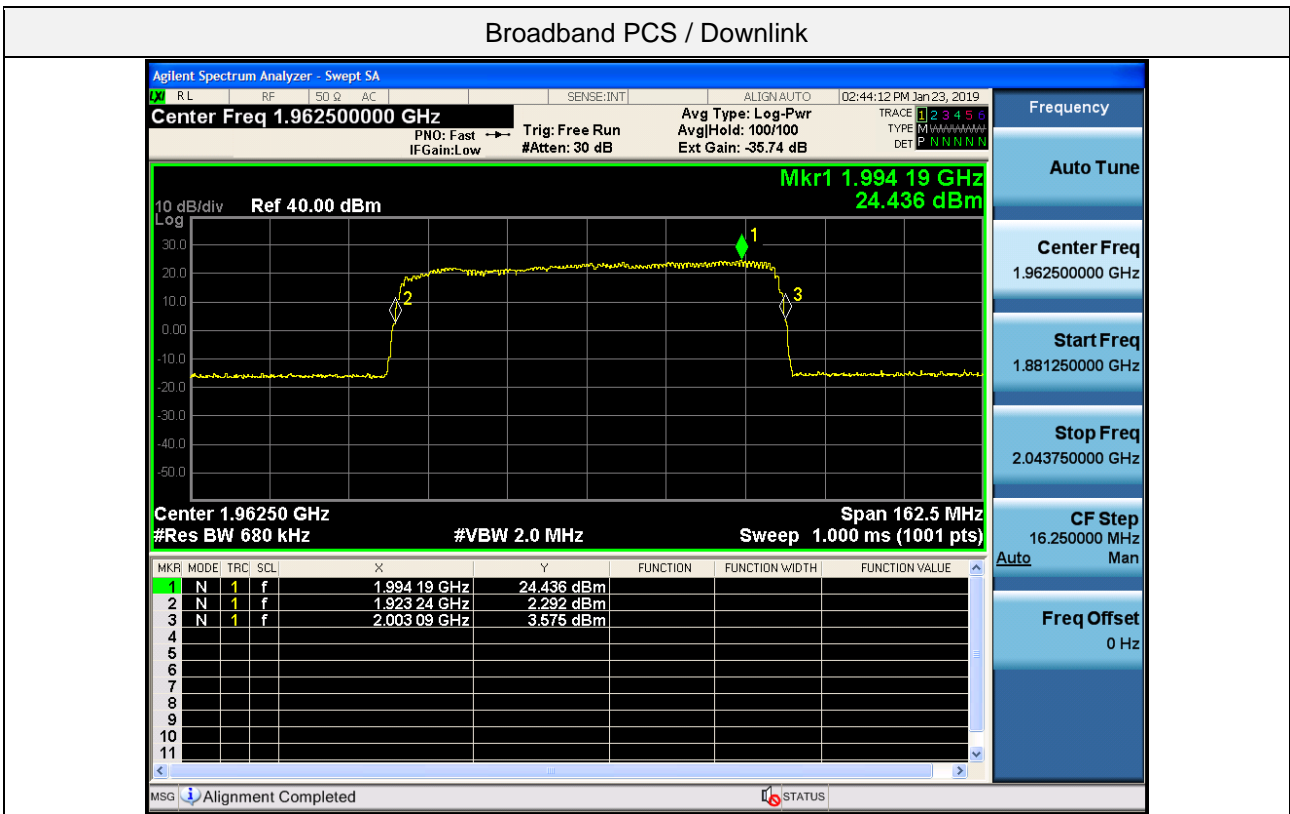

AWS1+3 / Downlink

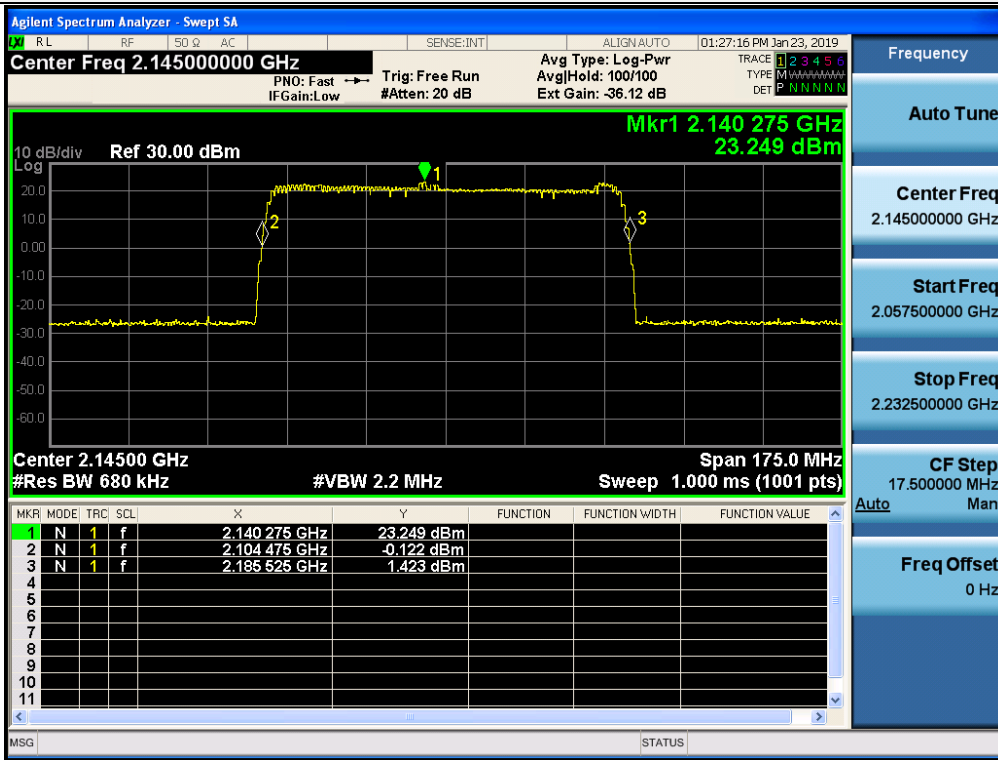

WCS / Downlink

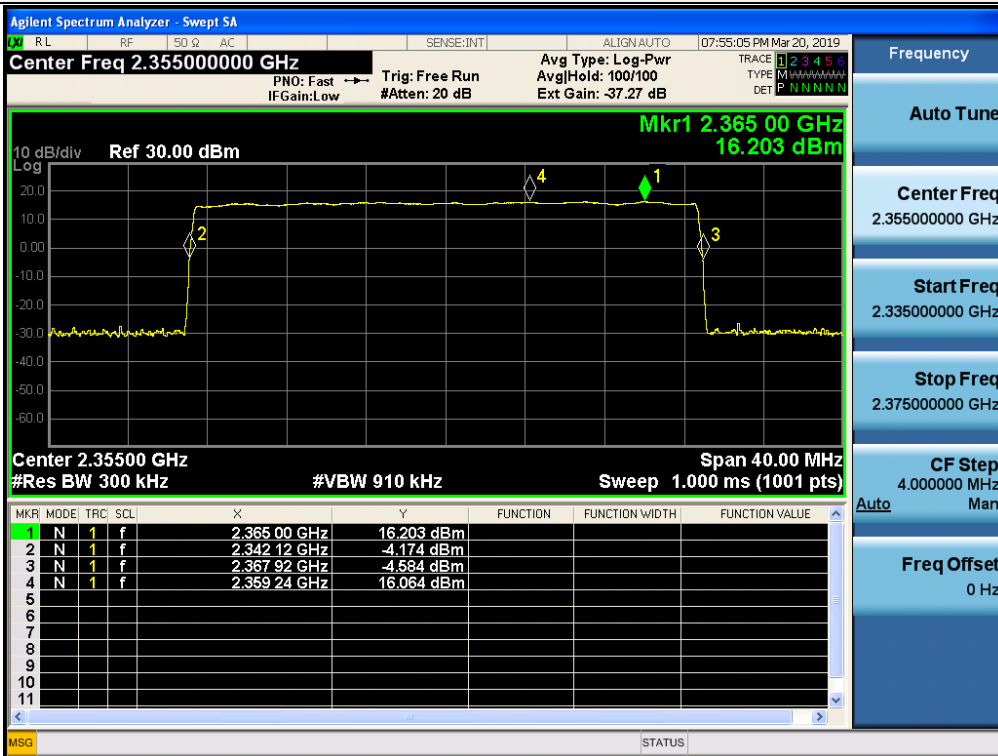

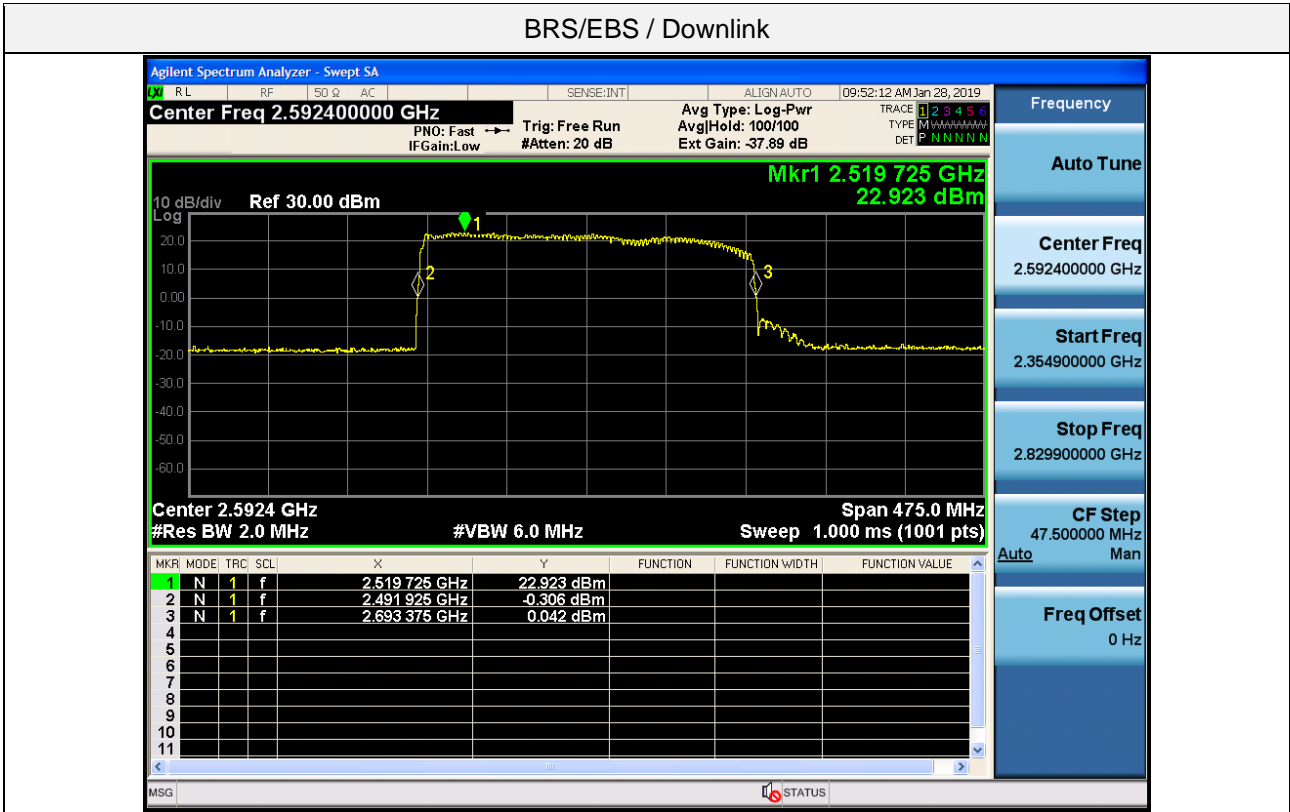

### 5.3. INPUT-VERSUS-OUTPUT SIGNAL COMPARISON

**Test Requirement:****§2.1049 Measurements required: Occupied bandwidth.**

The occupied bandwidth, that is the frequency bandwidth such that, below its lower and above its upper frequency limits, the mean powers radiated are each equal to 0.5 percent of the total mean power radiated by a given emission shall be measured under the specified conditions of § 2.1049 (a) through (i) as applicable.

**Test Procedures:**

Measurements were in accordance with the test methods section 3.4 of KDB 935210 D05 v01r02.

- a) Connect a signal generator to the input of the EUT.
- b) Configure the signal generator to transmit the AWGN signal.
- c) Configure the signal amplitude to be just below the AGC threshold level (see 3.2), but not more than 0.5 dB below.
- d) Connect a spectrum analyzer to the output of the EUT using appropriate attenuation.
- e) Set the spectrum analyzer center frequency to the center frequency of the operational band under test. The span range of the spectrum analyzer shall be between 2 times to 5 times the emission bandwidth (EBW) or alternatively, the OBW.
- f) The nominal RBW shall be in the range of 1 % to 5 % of the anticipated OBW, and the VBW shall be  $\geq 3 \times$  RBW.
- g) Set the reference level of the instrument as required to preclude the signal from exceeding the maximum spectrum analyzer input mixer level for linear operation. In general, the peak of the spectral envelope must be more than  $[10 \log (OBW / RBW)]$  below the reference level. Steps f) and g) may require iteration to enable adjustments within the specified tolerances.
- h) The noise floor of the spectrum analyzer at the selected RBW shall be at least 36 dB below the reference level.
- i) Set spectrum analyzer detection function to positive peak.
- j) Set the trace mode to max hold.
- k) Determine the reference value: Allow the trace to stabilize. Set the spectrum analyzer marker to the highest amplitude level of the displayed trace (this is the reference value) and record the associated frequency as  $f_0$ .
- l) Place two markers, one at the lowest and the other at the highest frequency of the envelope of the spectral display, such that each marker is at or slightly below the  $-26$  dB down amplitude. The 26 dB EBW (alternatively OBW) is the positive frequency difference between the two markers. If the spectral envelope crosses the  $-26$  dB down amplitude at multiple points, the lowest or highest frequency shall be selected as the frequencies that are the furthest removed from the center frequency at which the spectral envelope crosses the  $-26$  dB down amplitude point.

- m) Repeat steps e) to l) with the input signal connected directly to the spectrum analyzer (i.e., input signal measurement).
- n) Compare the spectral plot of the input signal (determined from step m) to the output signal (determined from step l) to affirm that they are similar (in passband and rolloff characteristic features and relative spectral locations), and include plot(s) and descriptions in test report.
- o) Repeat the procedure [steps e) to n)] with the input signal amplitude set to 3 dB above the AGC threshold.
- p) Repeat steps e) to o) with the signal generator set to the narrowband signal.
- q) Repeat steps e) to p) for all frequency bands authorized for use by the EUT.

**Test Results:**

**Tabular data of Output Occupied Bandwidth**

Test Band	Link	Signal	Center Frequency (MHz)	99 % OBW (MHz)	26 dB OBW (MHz)
Lower 700 MHz	Downlink	LTE 5 MHz	737.50	4.5158	4.999
		LTE 10 MHz	737.50	9.0034	9.940
Upper 700 MHz	Downlink	LTE 5 MHz	752.00	4.5081	5.017
		LTE 10 MHz	752.00	9.0027	10.030
PS Broadband	Downlink	LTE 5 MHz	763.00	4.5110	4.944
		LTE 10 MHz	763.00	8.9950	9.862
ESMR	Downlink	CDMA	865.50	1.2391	1.366
		WCDMA	865.50	4.1596	4.719
Cellular	Downlink	CDMA	881.50	1.2366	1.362
		WCDMA	881.50	4.1655	4.728
Broadband PCS	Downlink	CDMA	1962.50	1.2419	1.367
		WCDMA	1962.50	4.1637	4.691
		LTE 5 MHz	1962.50	4.5195	5.021
		LTE 10 MHz	1962.50	9.0125	10.03
		LTE 20 MHz	1962.50	17.948	19.73
AWS1+3	Downlink	LTE 5 MHz	2145.00	4.5172	5.034
		LTE 10 MHz	2145.00	9.0105	10.03
		LTE 20 MHz	2145.00	17.999	19.78
WCS	Downlink	LTE 5 MHz	2355.00	4.5126	4.985
		LTE 10 MHz	2355.00	9.0213	9.950
BRS/EBS	Downlink	LTE 5 MHz (TDD)	2592.40	4.4898	4.869
		LTE 10 MHz (TDD)	2592.40	8.9685	9.951
		LTE 20 MHz (TDD)	2592.40	17.942	19.85

Test Band	Link	Signal	Center Frequency (MHz)	99 % OBW (kHz)	26 dB OBW (kHz)
ESMR	Downlink	GSM	865.50	245.89	309.9
Cellular	Downlink	GSM	881.50	245.21	310.1
Broadband PCS	Downlink	GSM	1962.50	242.44	314.2

**Tabular data of Input Occupied Bandwidth**

Test Band	Link	Signal	Center Frequency (MHz)	99 % OBW (MHz)	26 dB OBW (MHz)
Lower 700 MHz	Downlink	LTE 5 MHz	737.50	4.5240	5.037
		LTE 10 MHz	737.50	9.0111	9.949
Upper 700 MHz	Downlink	LTE 5 MHz	752.00	4.5029	5.045
		LTE 10 MHz	752.00	9.0033	10.043
PS Broadband	Downlink	LTE 5 MHz	763.00	4.5011	5.028
		LTE 10 MHz	763.00	9.0192	9.969
ESMR	Downlink	CDMA	865.50	1.2376	1.370
		WCDMA	865.50	4.1786	4.705
Cellular	Downlink	CDMA	881.50	1.2378	1.363
		WCDMA	881.50	4.1800	4.687
Broadband PCS	Downlink	CDMA	1962.50	1.2392	1.359
		WCDMA	1962.50	4.1855	4.723
		LTE 5 MHz	1962.50	4.5336	4.986
		LTE 10 MHz	1962.50	9.0119	9.947
		LTE 20 MHz	1962.50	18.028	19.85
AWS1+3	Downlink	LTE 5 MHz	2145.00	4.5199	4.977
		LTE 10 MHz	2145.00	9.0274	10.02
		LTE 20 MHz	2145.00	17.998	20.07
WCS	Downlink	LTE 5 MHz	2355.00	4.5135	5.015
		LTE 10 MHz	2355.00	9.0164	9.949
BRS/EBS	Downlink	LTE 5 MHz (TDD)	2592.40	4.4963	4.969
		LTE 10 MHz (TDD)	2592.40	8.9555	9.947
		LTE 20 MHz (TDD)	2592.40	17.920	19.98

Test Band	Link	Signal	Center Frequency (MHz)	99 % OBW (kHz)	26 dB OBW (kHz)
ESMR	Downlink	GSM	865.50	244.13	312.3
Cellular	Downlink	GSM	881.50	245.67	315.6
Broadband PCS	Downlink	GSM	1962.50	243.54	306.5

**Tabular data of 3 dB above the AGC threshold Output Occupied Bandwidth**

Test Band	Link	Signal	Center Frequency (MHz)	99 % OBW (MHz)	26 dB OBW (MHz)
Lower 700 MHz	Downlink	LTE 5 MHz	737.50	4.5132	5.009
		LTE 10 MHz	737.50	9.0227	10.020
Upper 700 MHz	Downlink	LTE 5 MHz	752.00	4.5144	5.042
		LTE 10 MHz	752.00	9.0205	9.854
PS Broadband	Downlink	LTE 5 MHz	763.00	4.5095	5.048
		LTE 10 MHz	763.00	8.9957	9.950
ESMR	Downlink	CDMA	865.50	1.2422	1.370
		WCDMA	865.50	4.1667	4.706
Cellular	Downlink	CDMA	881.50	1.2346	1.369
		WCDMA	881.50	4.1726	4.715
Broadband PCS	Downlink	CDMA	1962.50	1.2393	1.363
		WCDMA	1962.50	4.1687	4.695
		LTE 5 MHz	1962.50	4.5176	5.032
		LTE 10 MHz	1962.50	8.9982	9.907
		LTE 20 MHz	1962.50	17.974	19.68
AWS1+3	Downlink	LTE 5 MHz	2145.00	4.5136	4.986
		LTE 10 MHz	2145.00	9.0072	9.963
		LTE 20 MHz	2145.00	17.957	19.82
WCS	Downlink	LTE 5 MHz	2355.00	4.5145	5.006
		LTE 10 MHz	2355.00	9.0096	9.940
BRS/EBS	Downlink	LTE 5 MHz (TDD)	2592.40	4.4979	4.894
		LTE 10 MHz (TDD)	2592.40	8.9983	9.851
		LTE 20 MHz (TDD)	2592.40	17.929	20.00

Test Band	Link	Signal	Center Frequency (MHz)	99 % OBW (kHz)	26 dB OBW (kHz)
ESMR	Downlink	GSM	865.50	245.00	309.1
Cellular	Downlink	GSM	881.50	243.60	311.6
Broadband PCS	Downlink	GSM	1962.50	243.05	312.7



**Measured Occupied Bandwidth Comparison**

Test Band	Link	Signal	Variation of Input and output Occupied Bandwidth (%)	Variation of Input and 3 dB above the AGC threshold output Occupied Bandwidth (%)
Lower 700 MHz	Downlink	LTE 5 MHz	-0.754	-0.556
		LTE 10 MHz	-0.090	0.714
Upper 700 MHz	Downlink	LTE 5 MHz	-0.555	-0.059
		LTE 10 MHz	-0.129	-1.882
PS Broadband	Downlink	LTE 5 MHz	-1.671	0.398
		LTE 10 MHz	-1.073	-0.191
ESMR	Downlink	GSM	-0.772	-1.038
		CDMA	-0.292	0.000
		WCDMA	0.298	0.021
Cellular	Downlink	GSM	-1.756	-1.275
		CDMA	-0.073	0.440
		WCDMA	0.875	0.597
Broadband PCS	Downlink	GSM	2.520	2.013
		CDMA	0.589	0.294
		WCDMA	-0.678	-0.593
		LTE 5 MHz	0.702	0.923
		LTE 10 MHz	0.814	-0.402
		LTE 20 MHz	-0.605	-0.856
AWS1+3	Downlink	LTE 5 MHz	1.145	0.181
		LTE 10 MHz	0.180	-0.539
		LTE 20 MHz	-1.445	-1.246
WCS	Downlink	LTE 5 MHz	-0.598	-0.179
		LTE 10 MHz	0.010	-0.090
BRS/EBS	Downlink	LTE 5 MHz (TDD)	-2.012	-1.509
		LTE 10 MHz (TDD)	0.040	-0.965
		LTE 20 MHz (TDD)	-0.651	0.100

Test Band	Link	Signal	Variation of Input and output Occupied Bandwidth (%)	Variation of Input and 3 dB above the AGC threshold output Occupied Bandwidth (%)
ESMR	Downlink	GSM	-0.772	-1.038
Cellular	Downlink	GSM	-1.756	-1.275
Broadband PCS	Downlink	GSM	2.520	2.013

\* Change in input-output OBW is less than  $\pm 5\%$ .

**Plot data of Occupied Bandwidth**

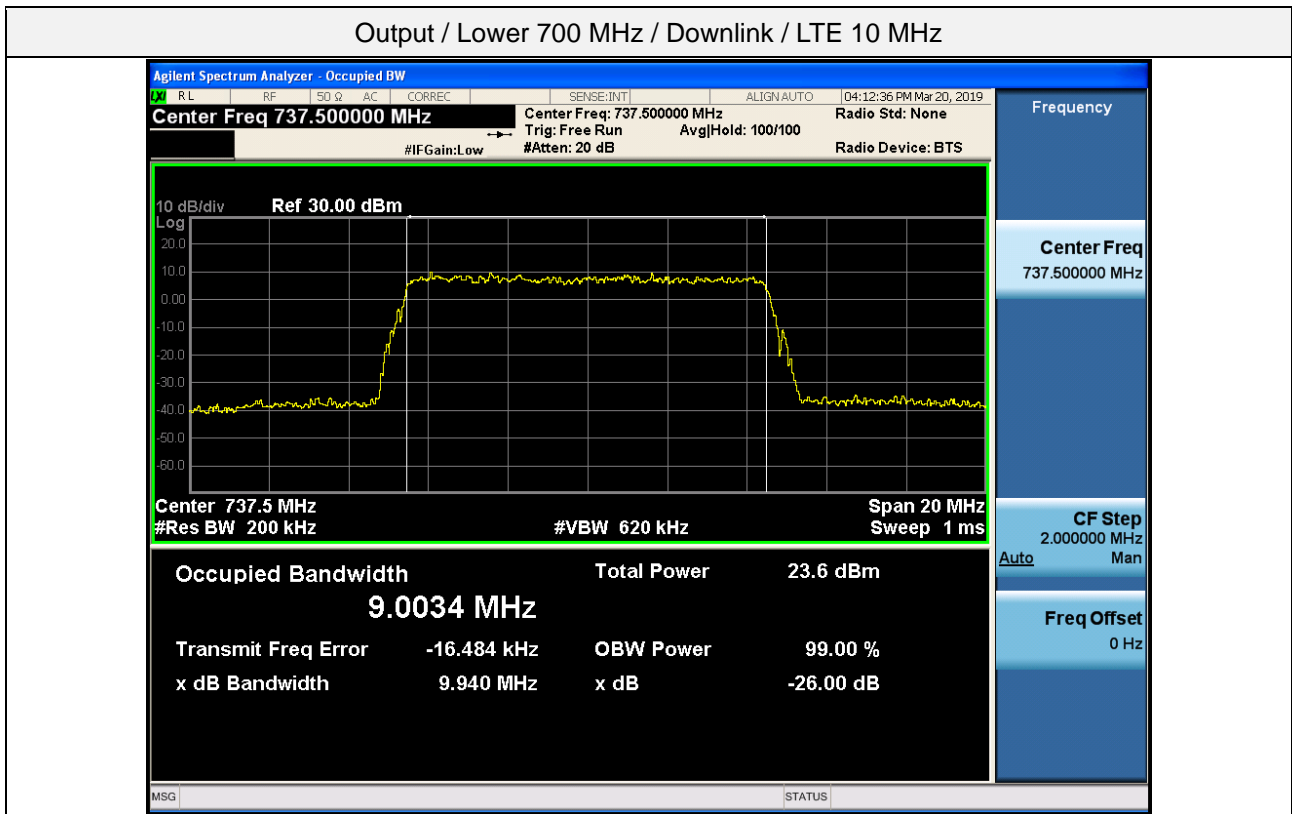
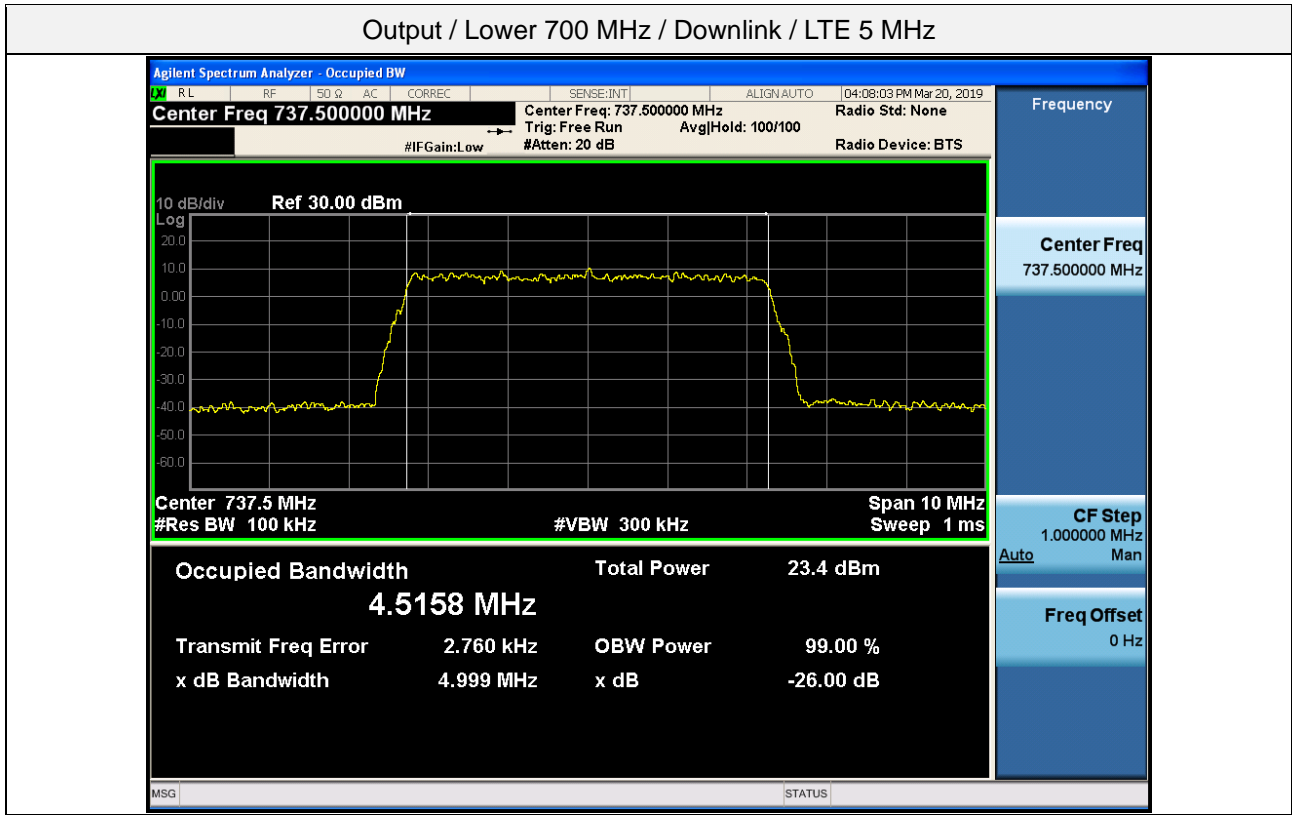

Output / Upper 700 MHz / Downlink / LTE 5 MHz

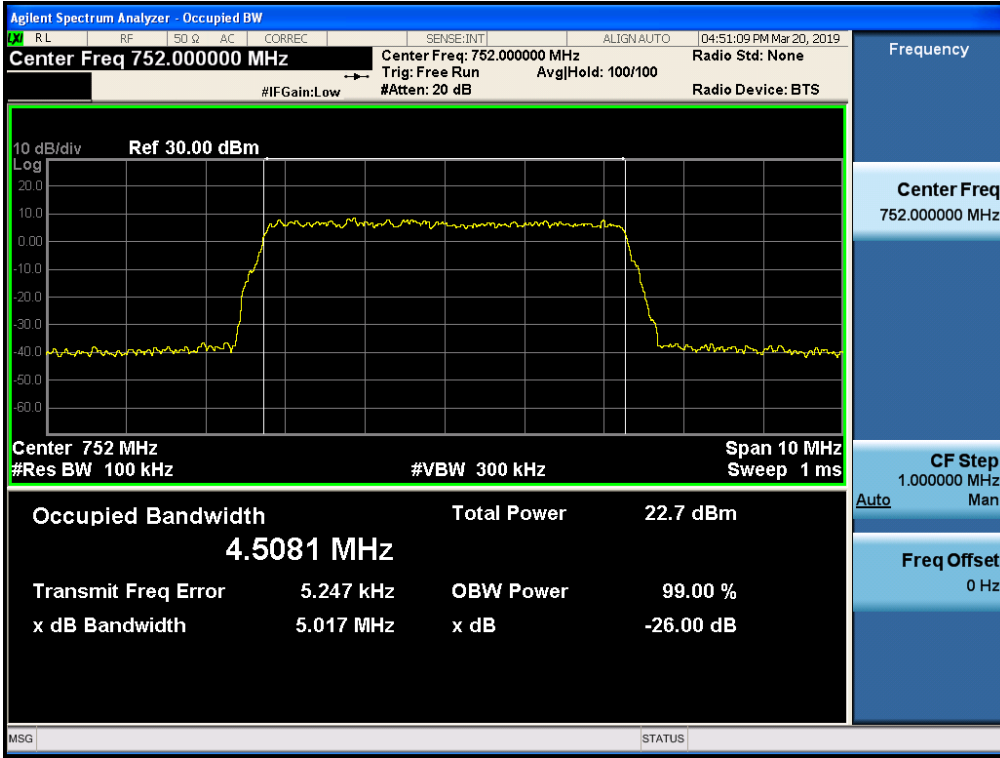

Output / Upper 700 MHz / Downlink / LTE 10 MHz

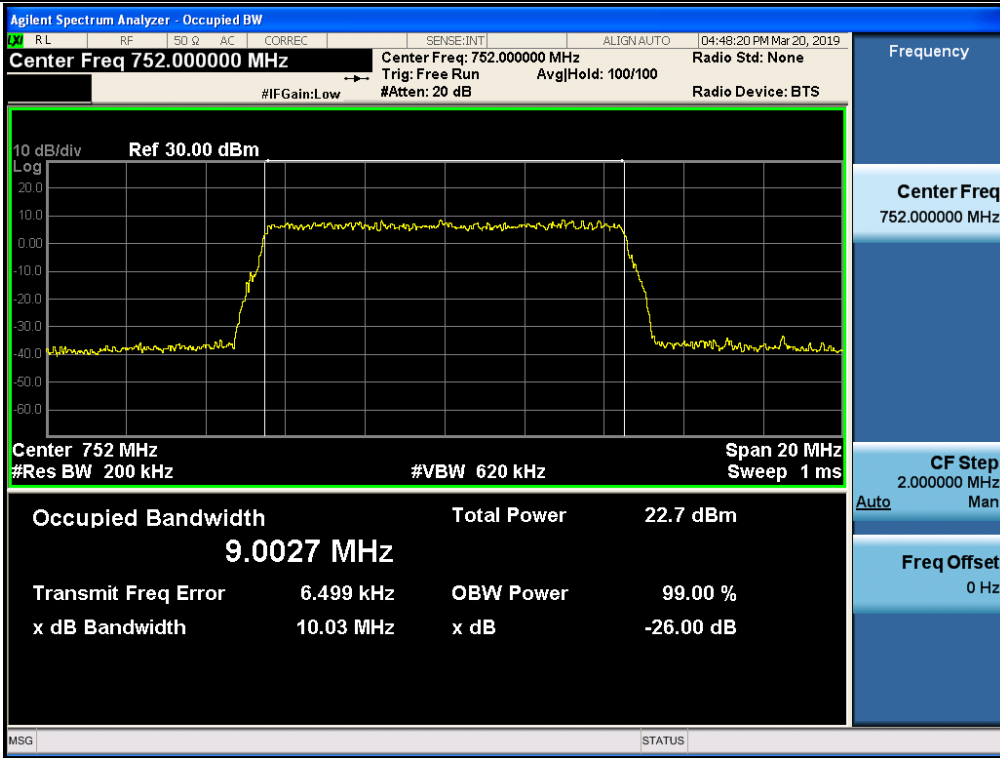

Output / PS Broadband / Downlink / LTE 5 MHz

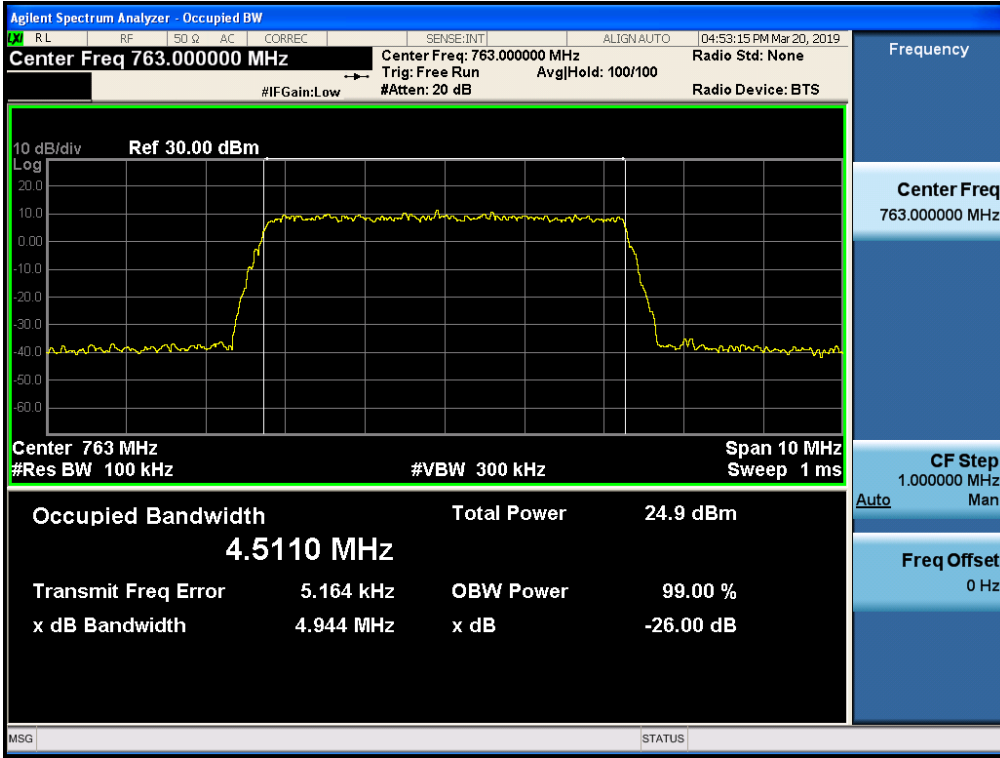

Output / PS Broadband / Downlink / LTE 10 MHz

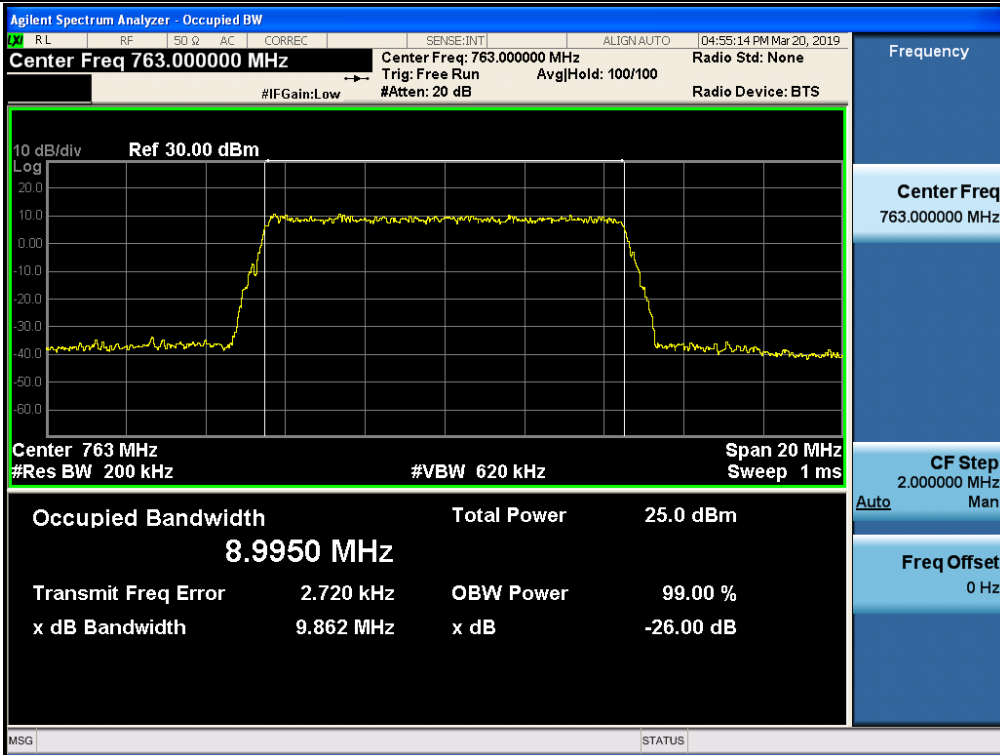

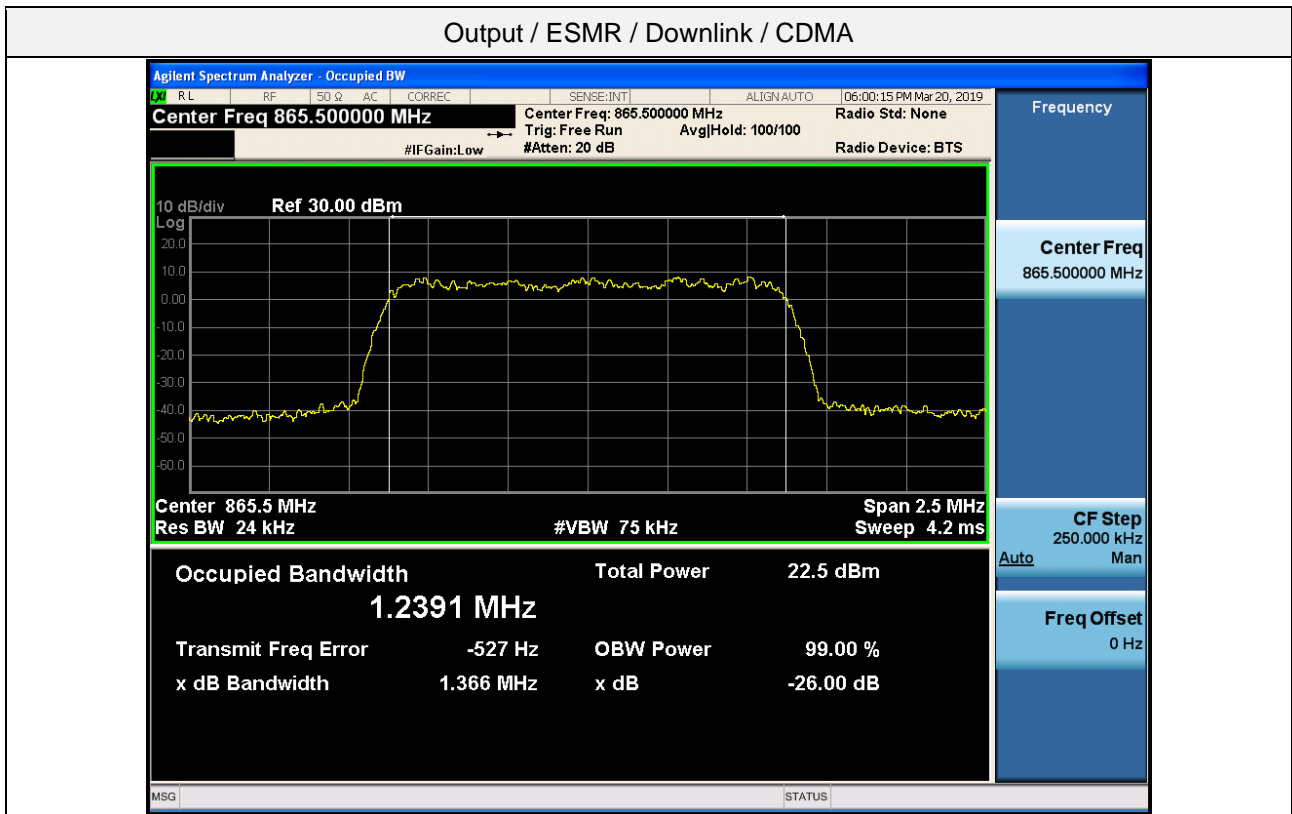
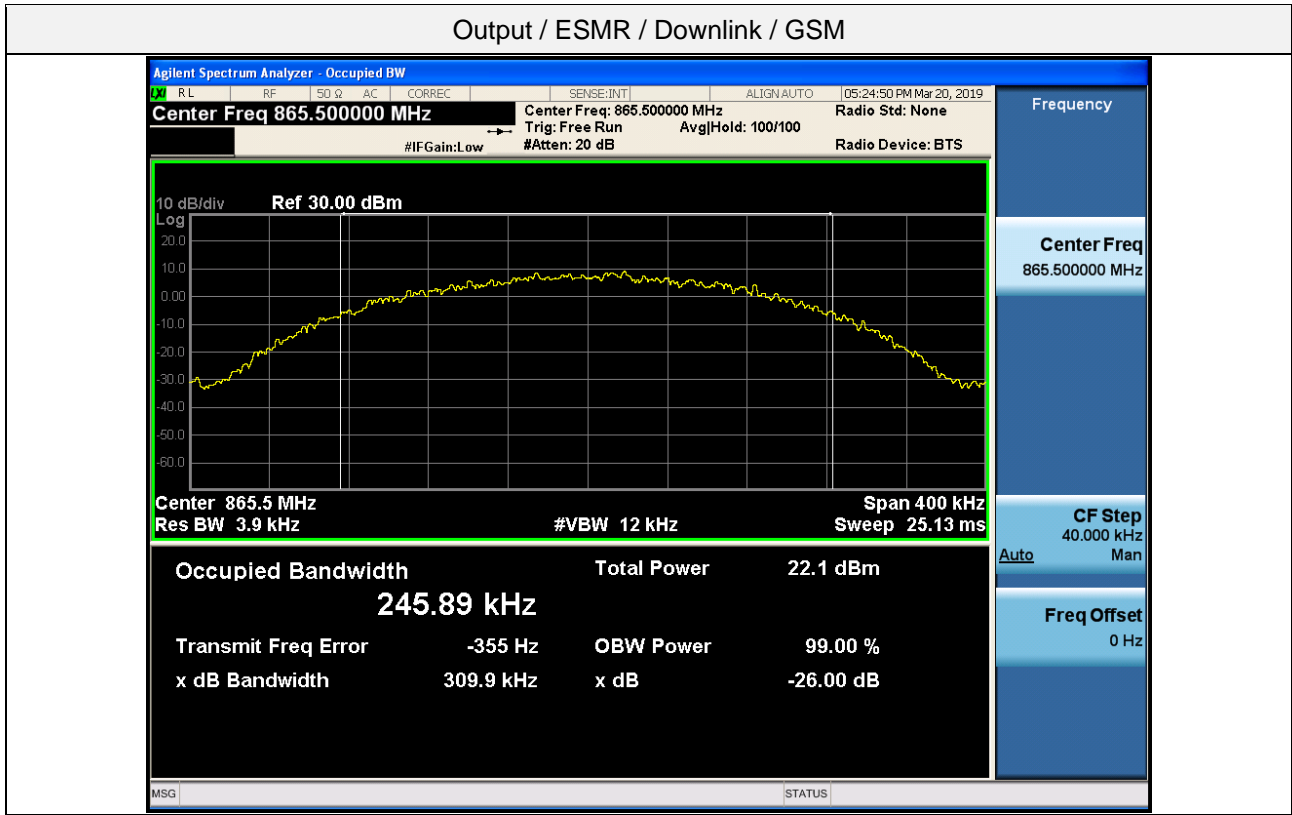

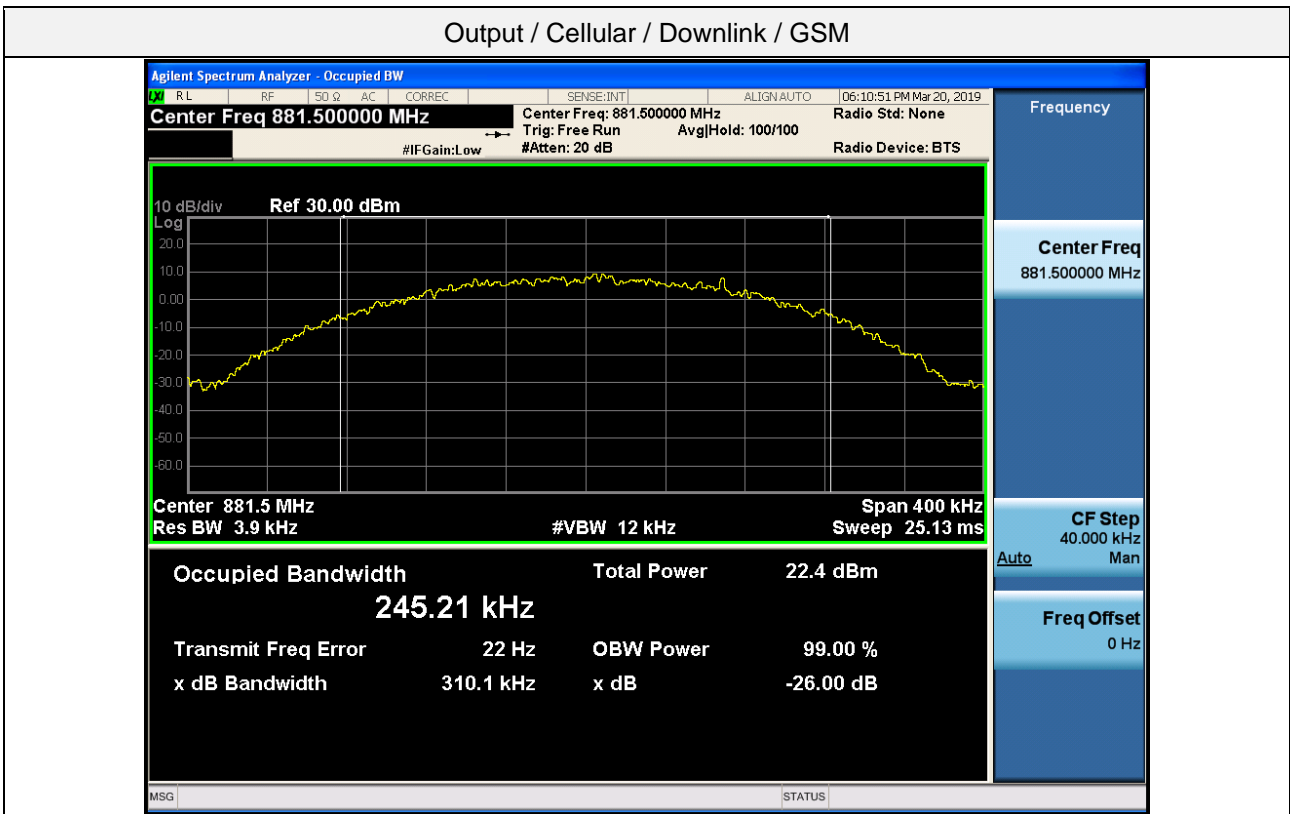
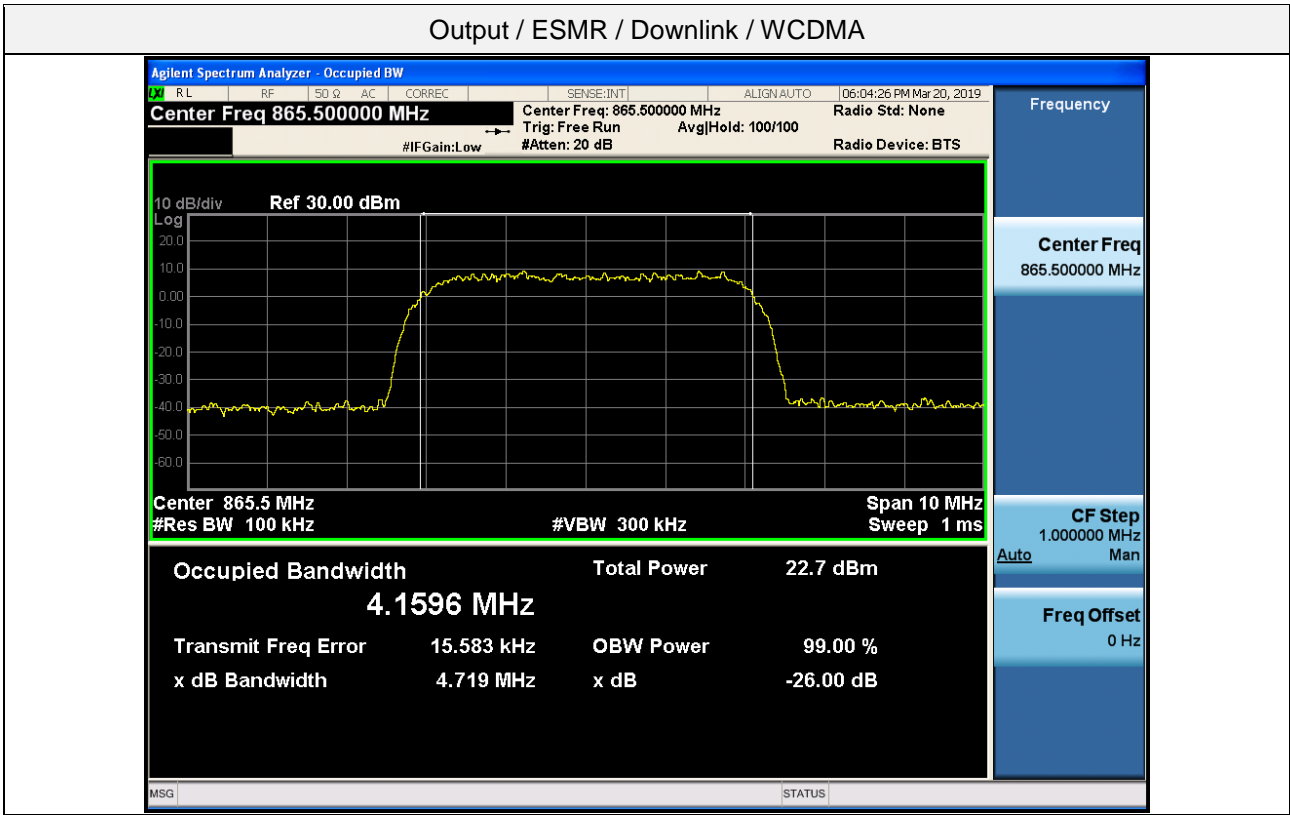

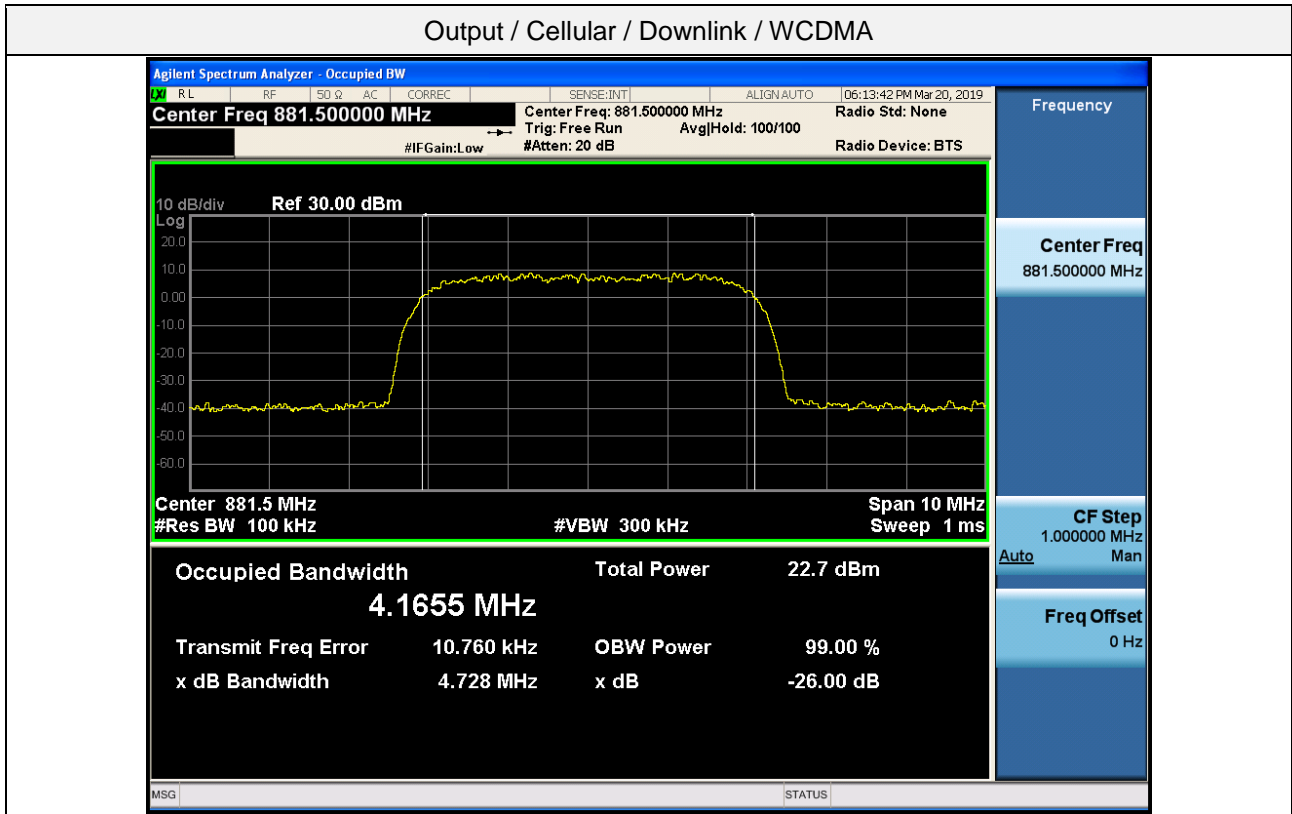
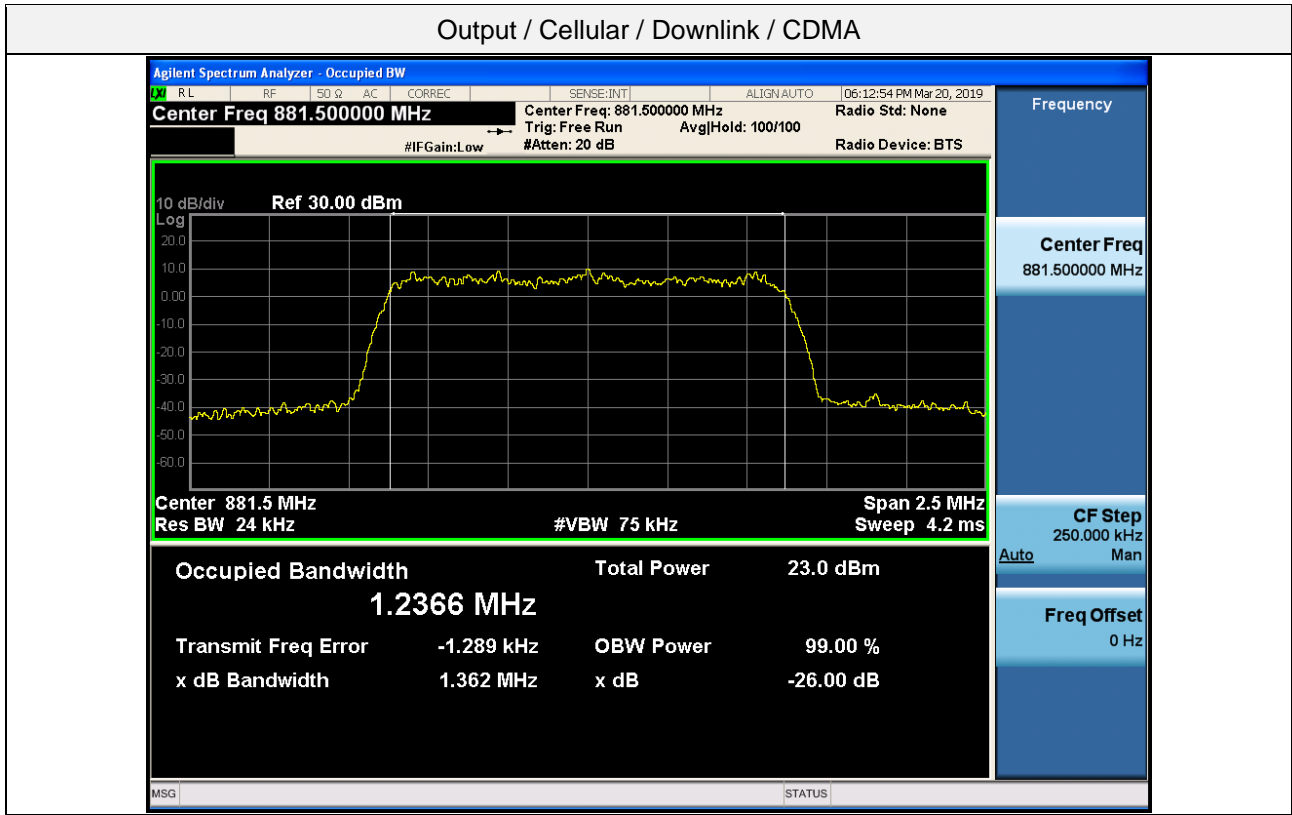

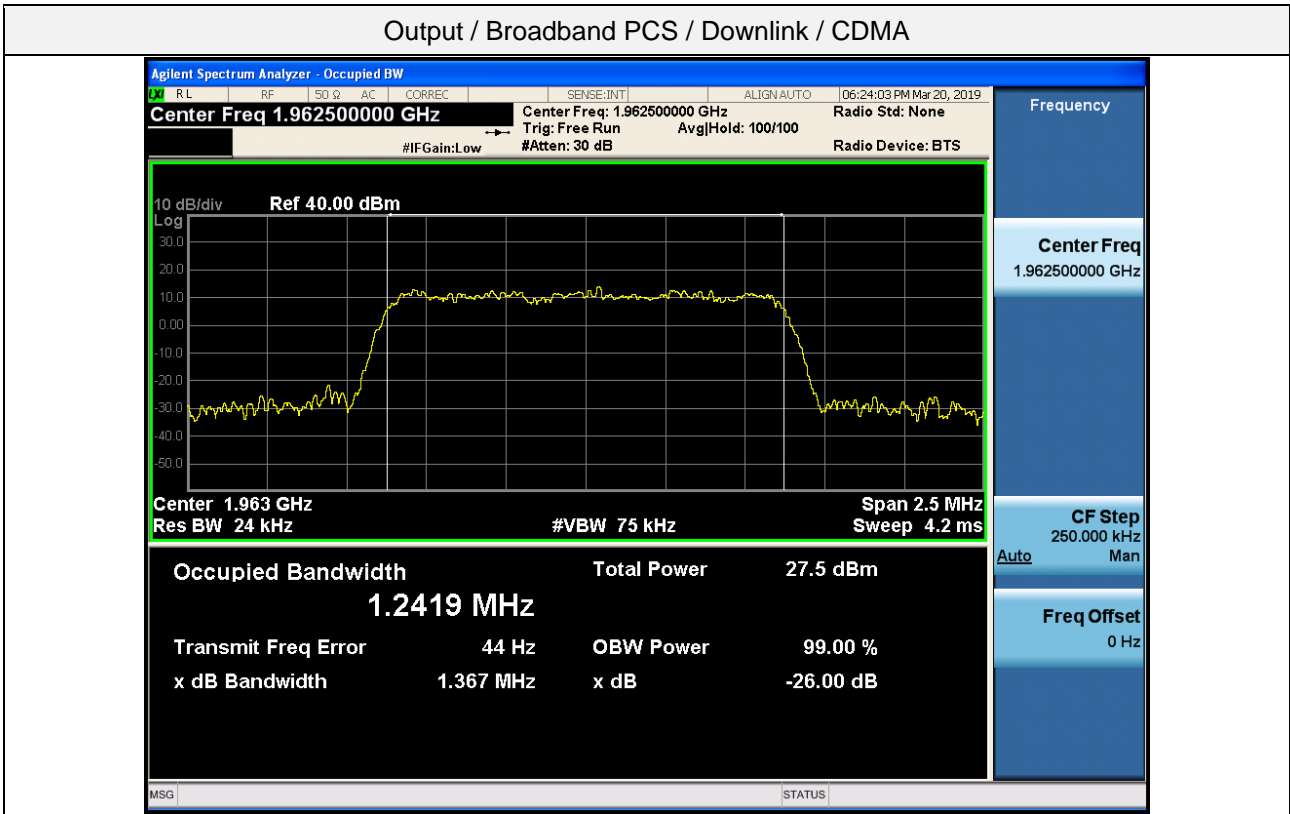
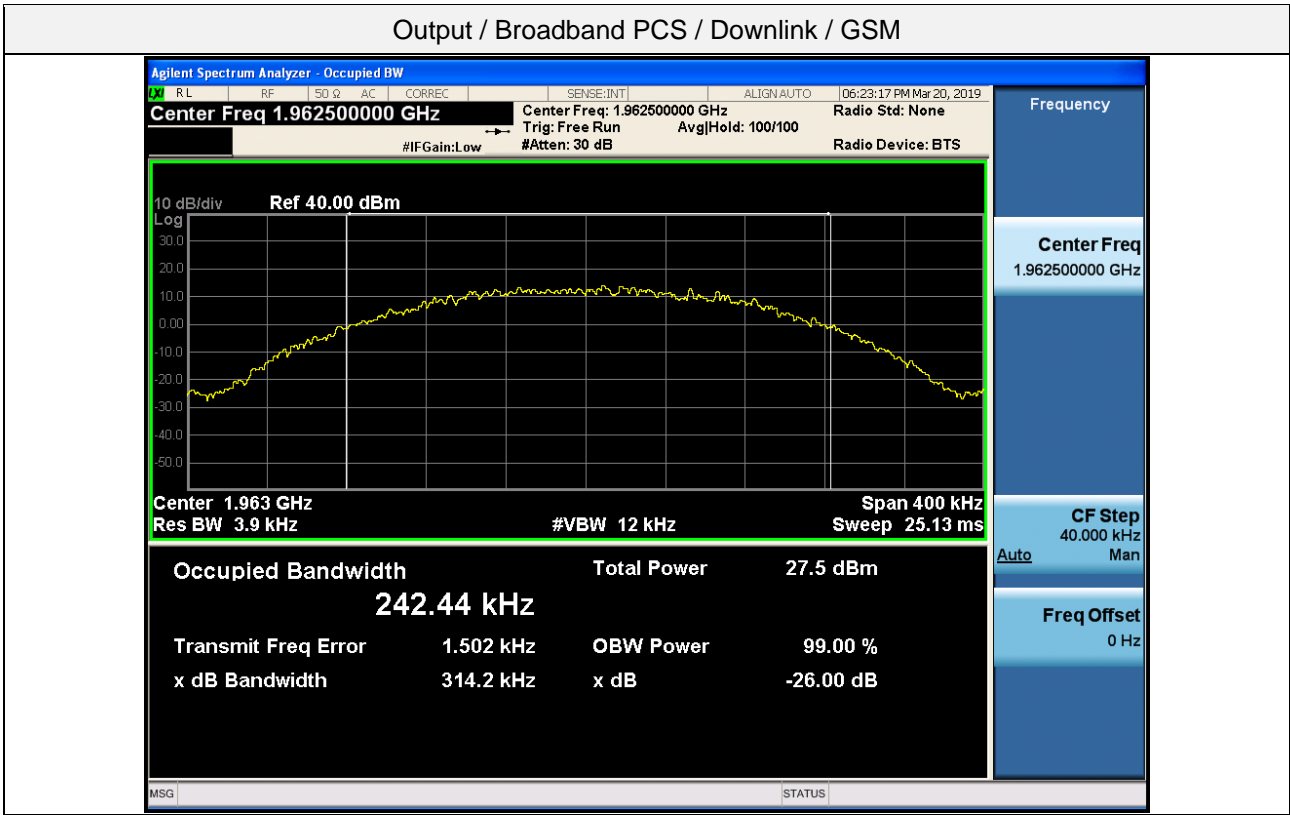



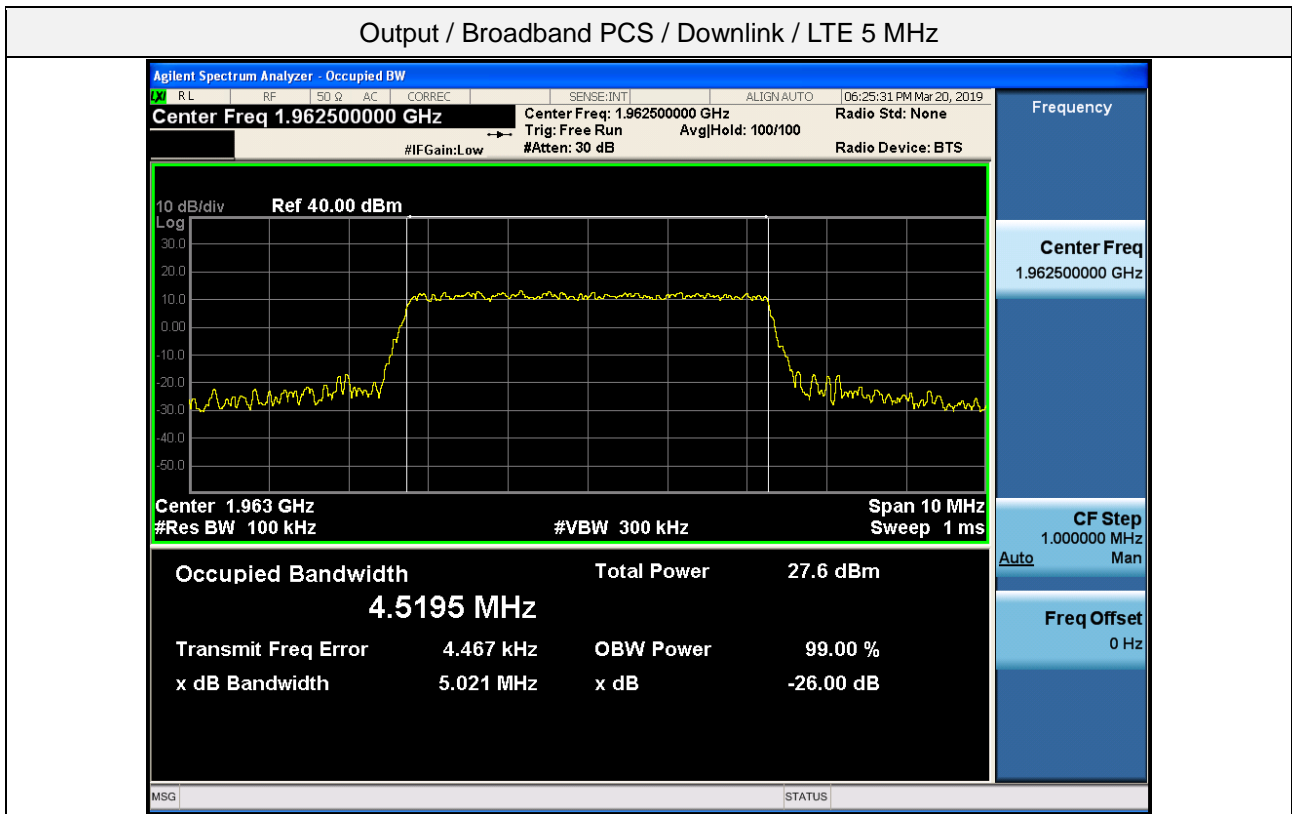
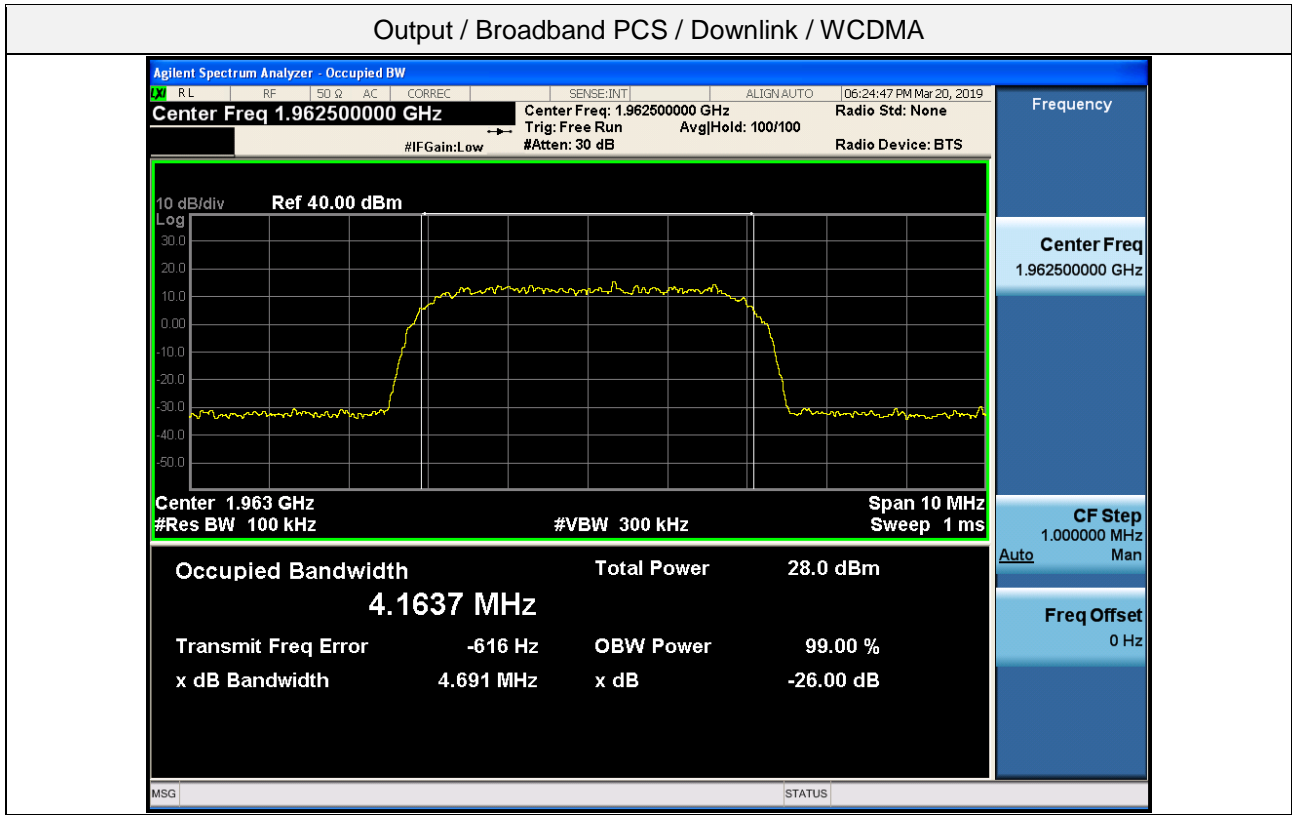

Output / Broadband PCS / Downlink / LTE 10 MHz

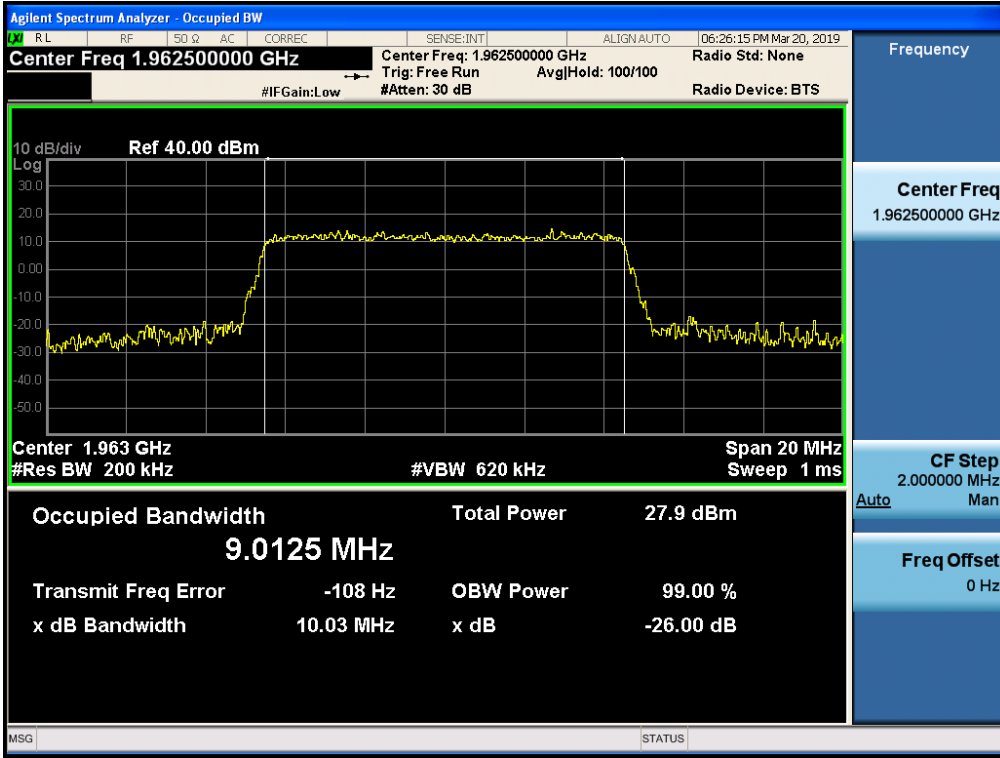

Output / Broadband PCS / Downlink / LTE 20 MHz

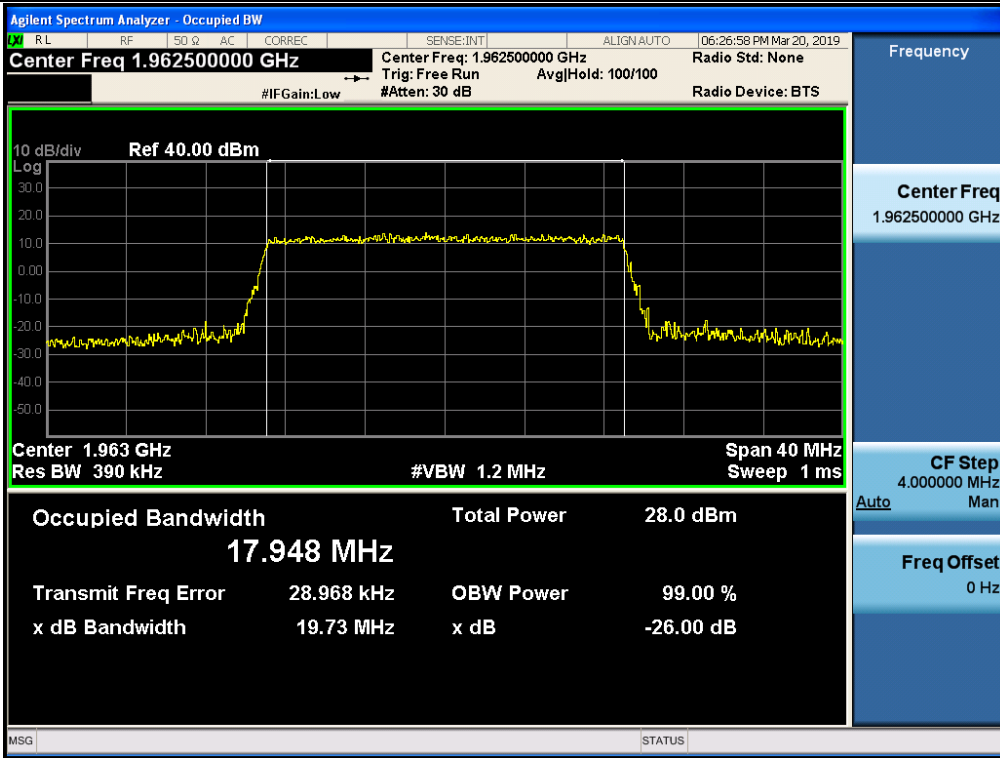

Output / AWS1+3 / Downlink / LTE 5 MHz

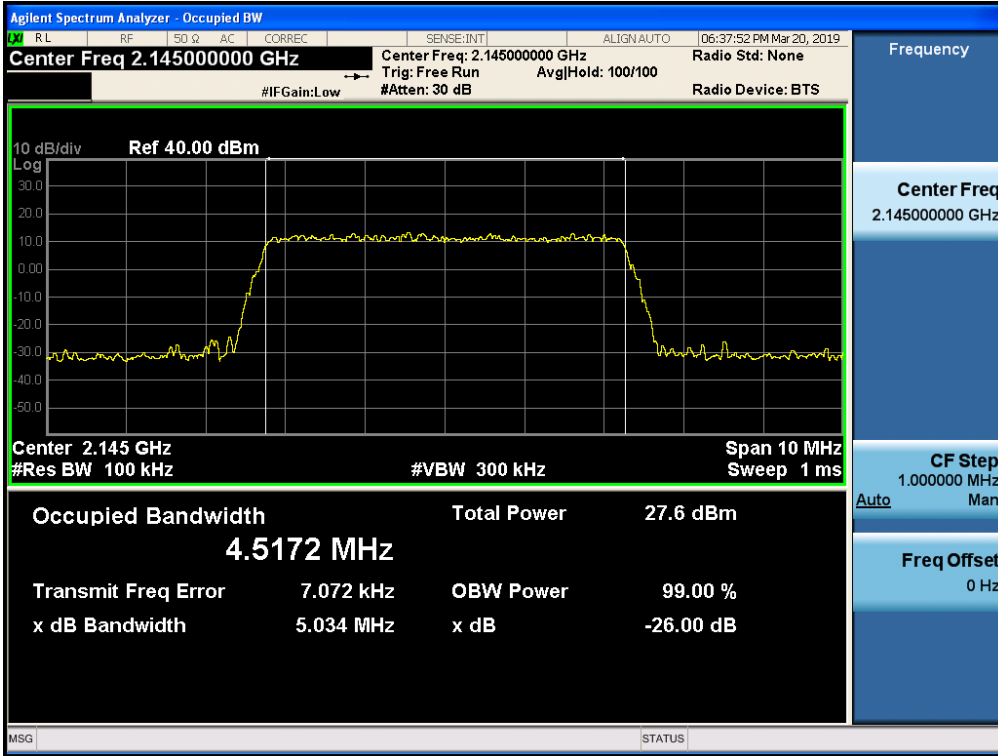

Output / AWS1+3 / Downlink / LTE 10 MHz

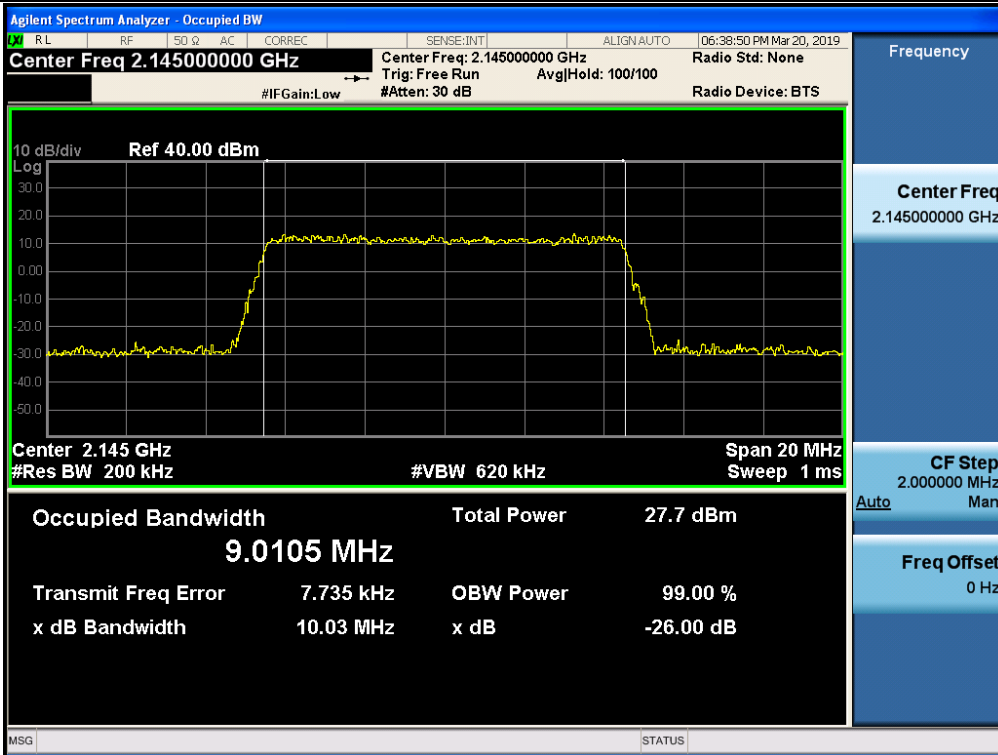

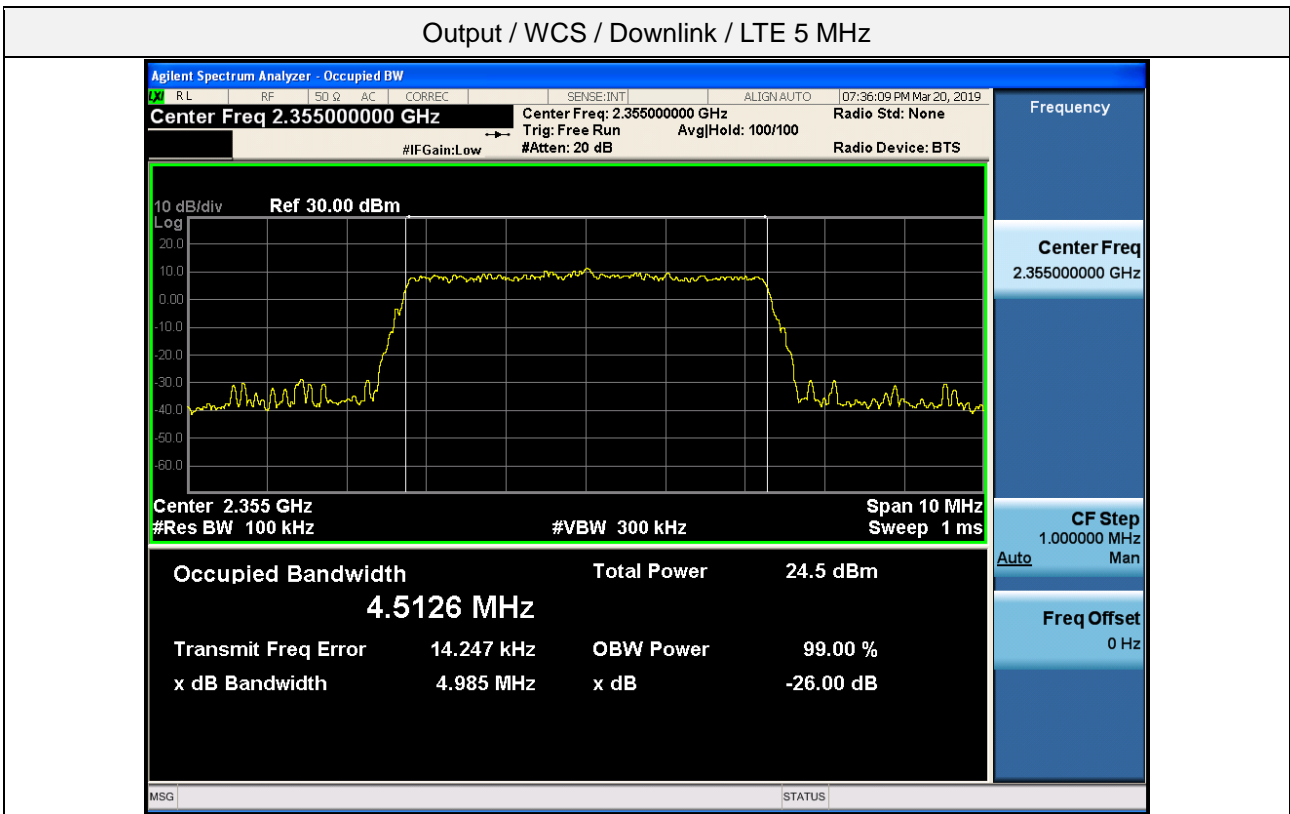
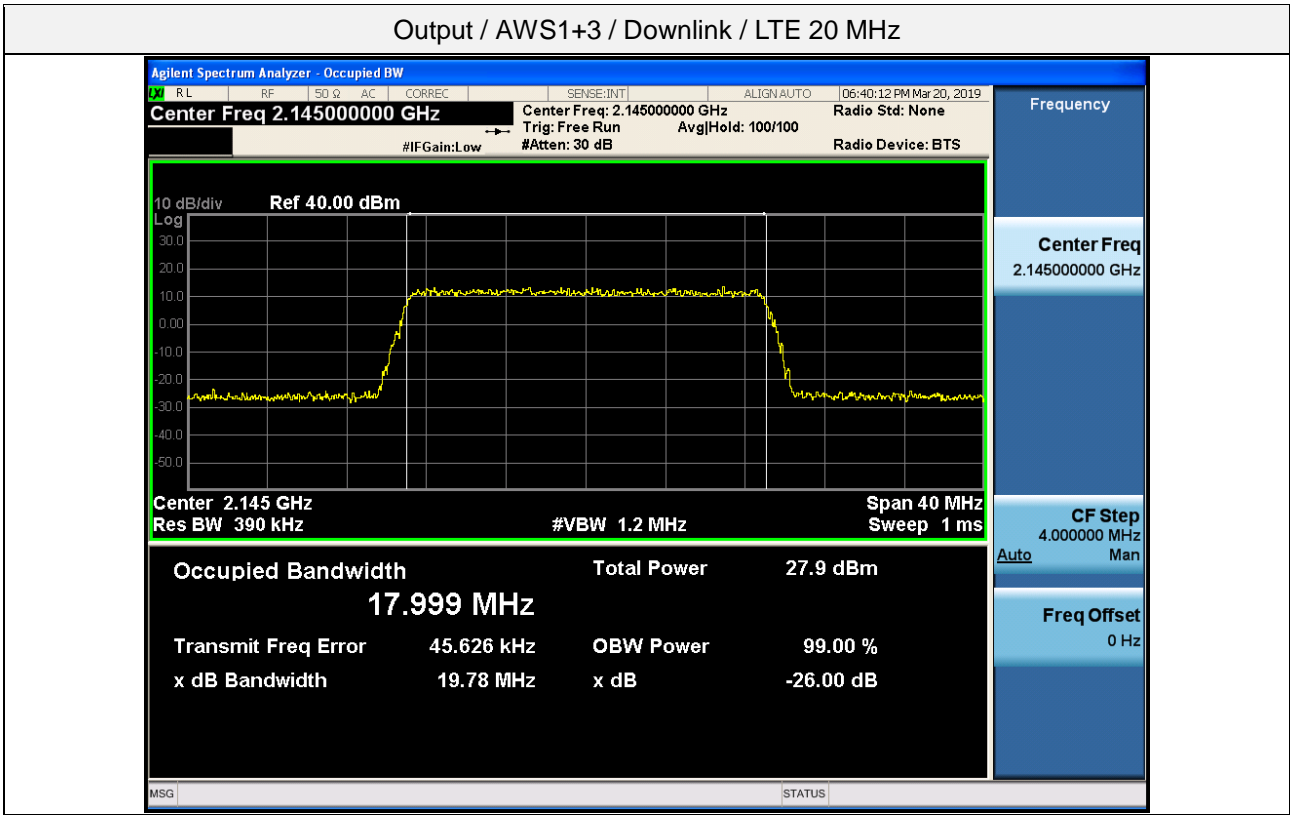

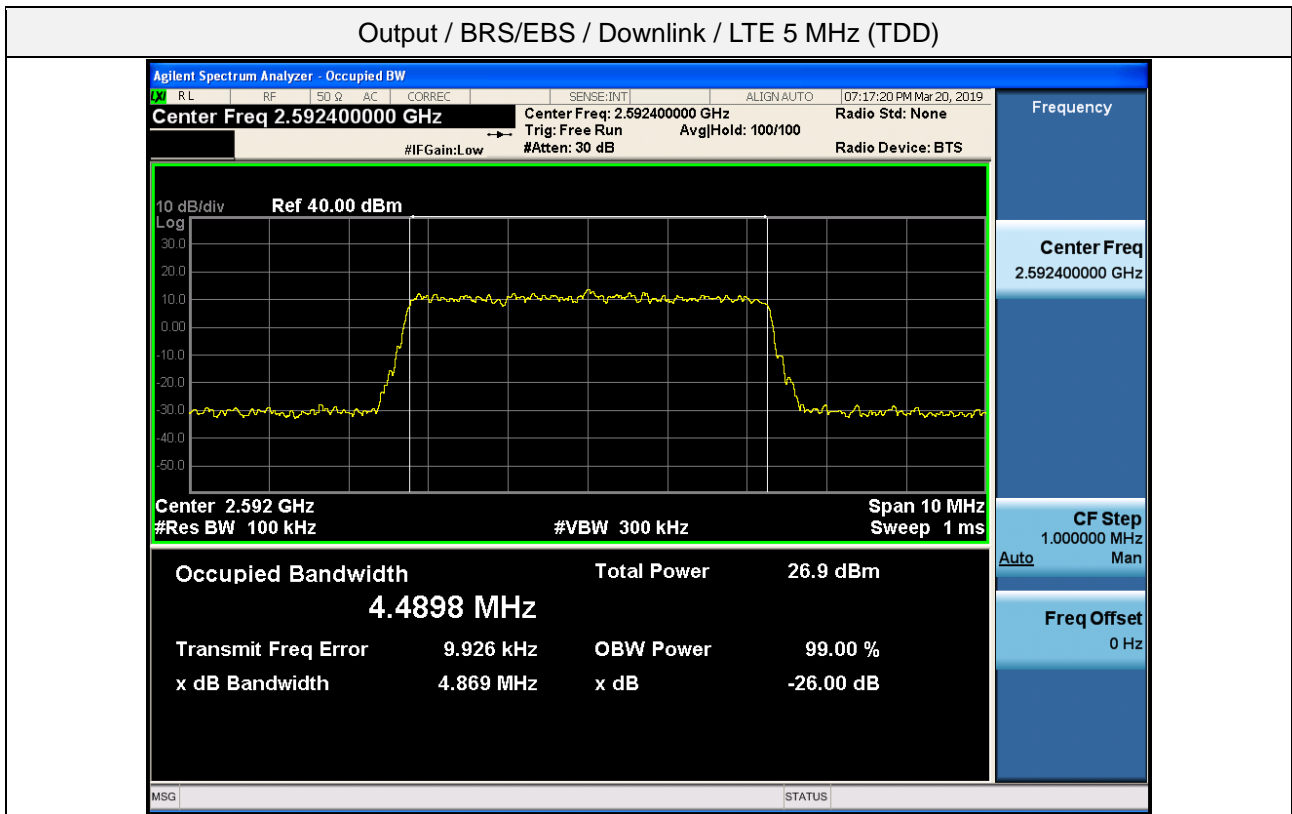
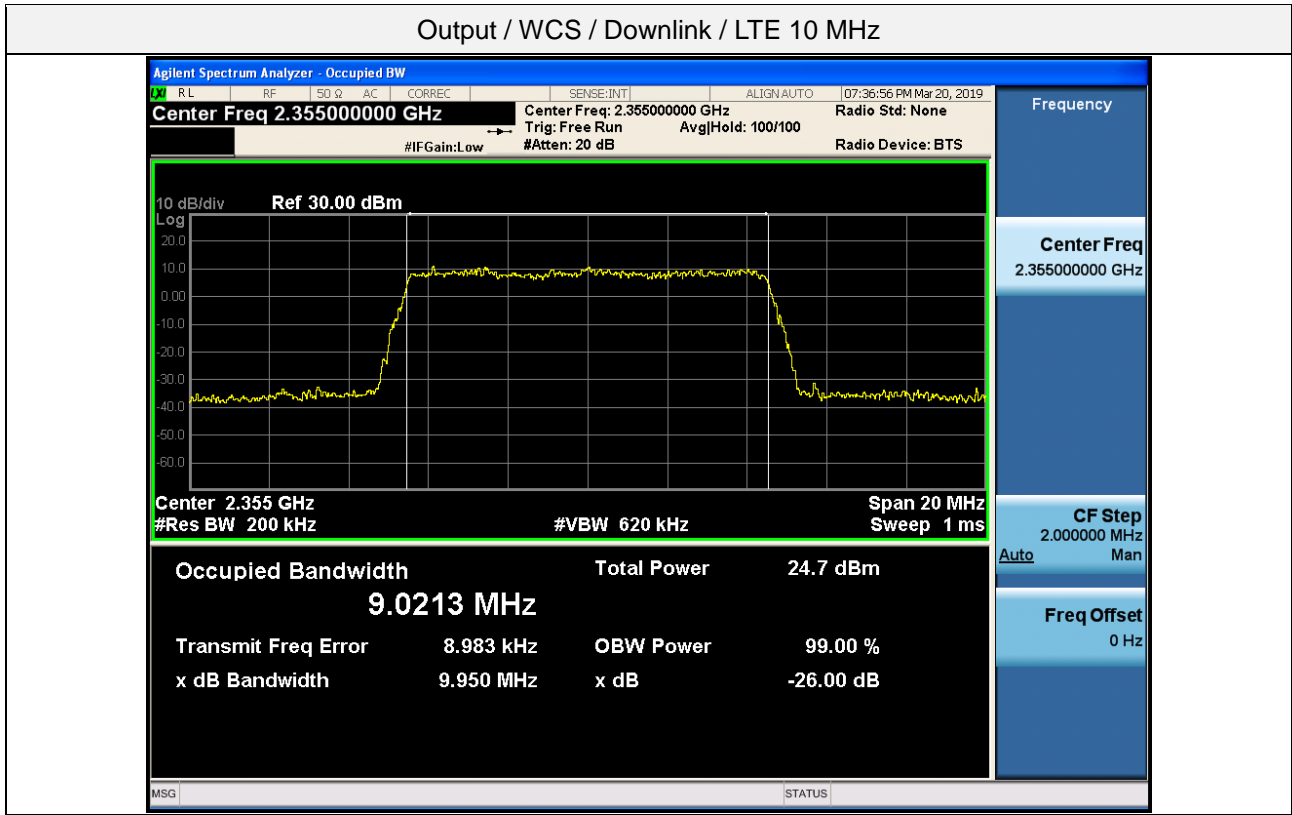

Output / BRS/EBS / Downlink / LTE 10 MHz (TDD)

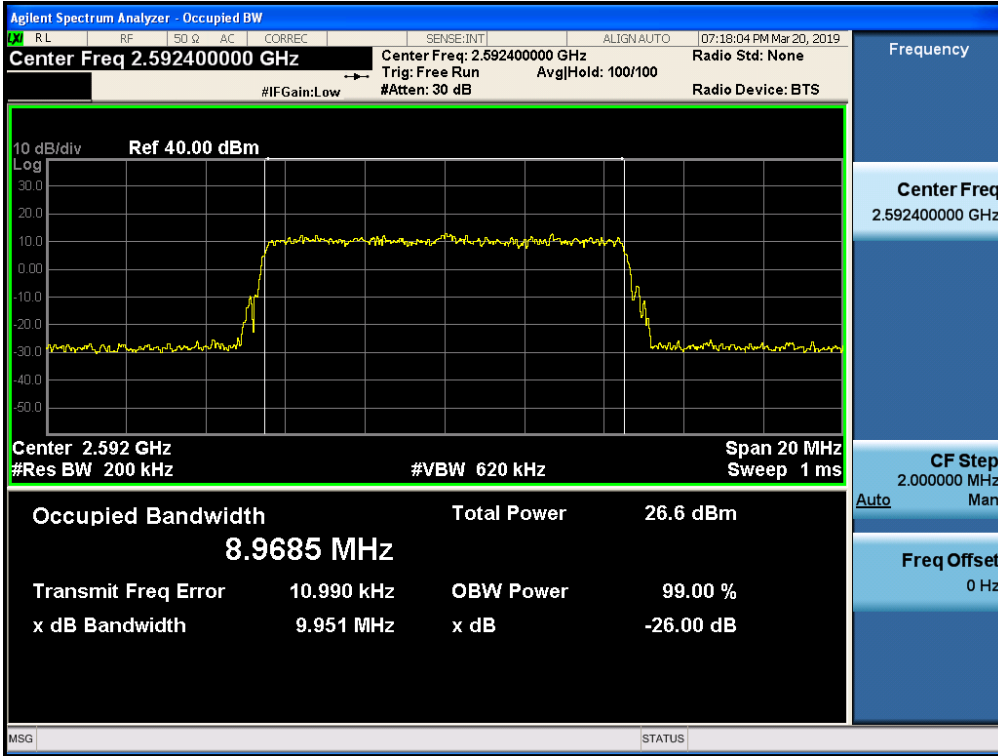

Output / BRS/EBS / Downlink / LTE 20 MHz (TDD)

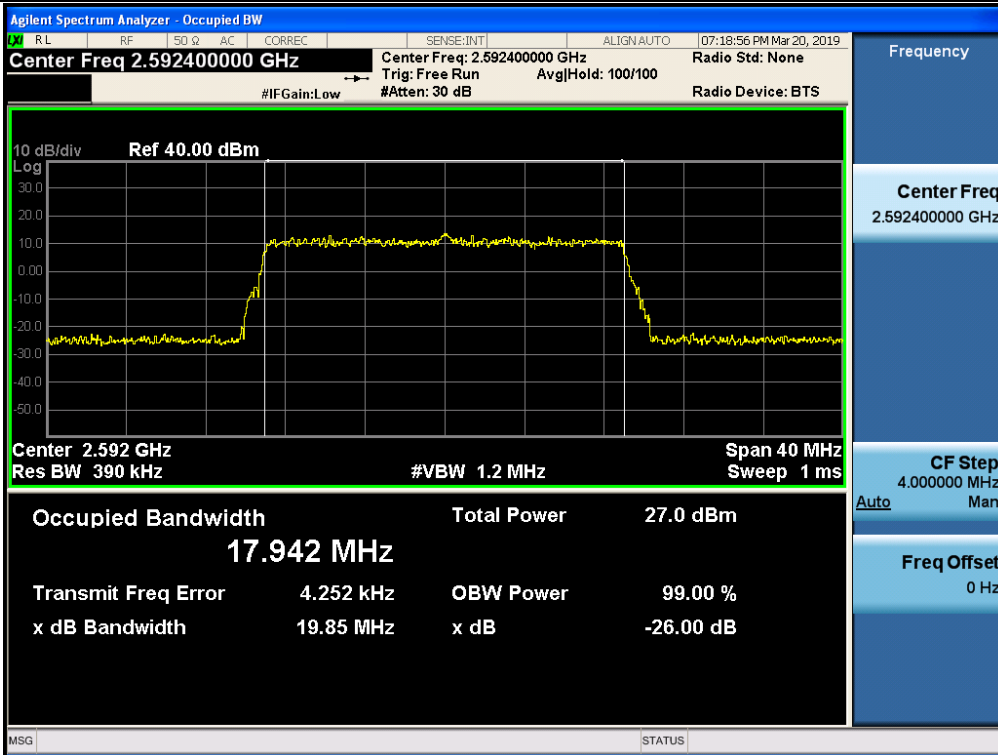

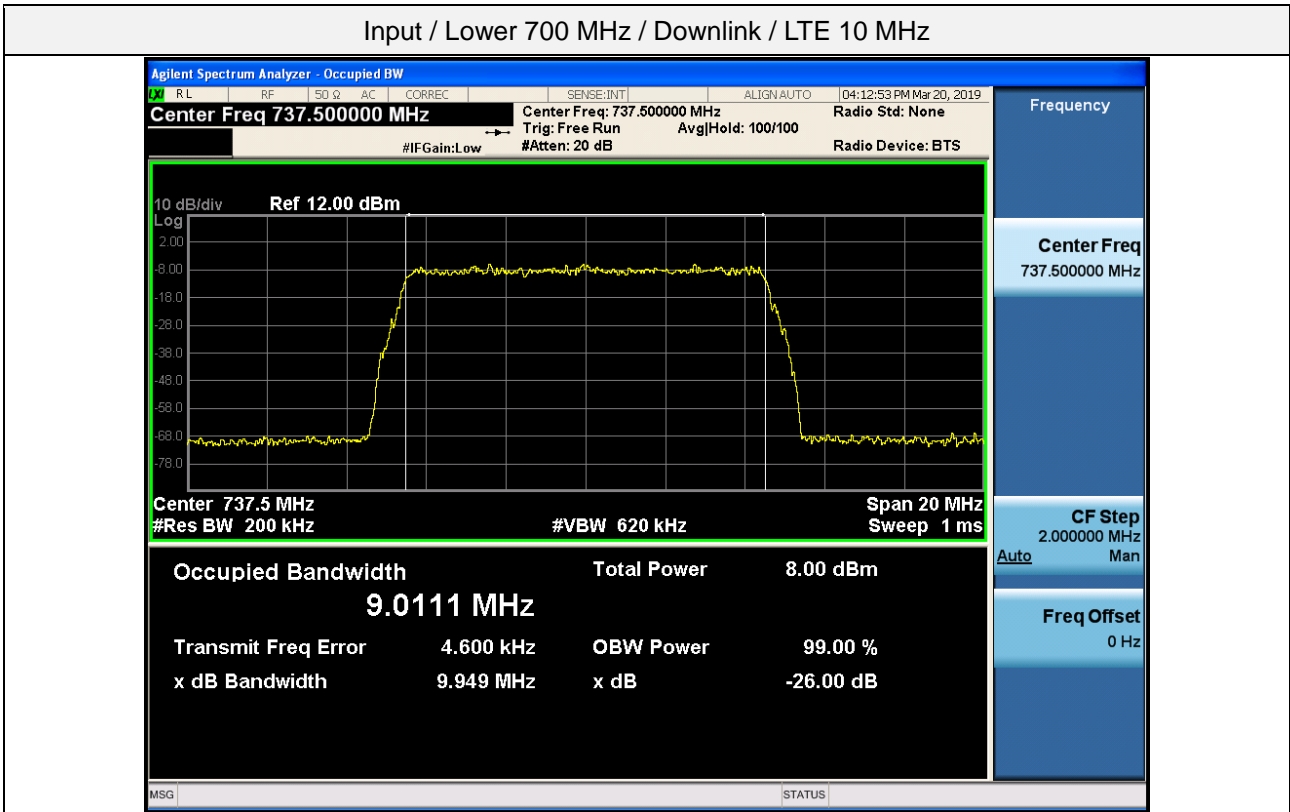
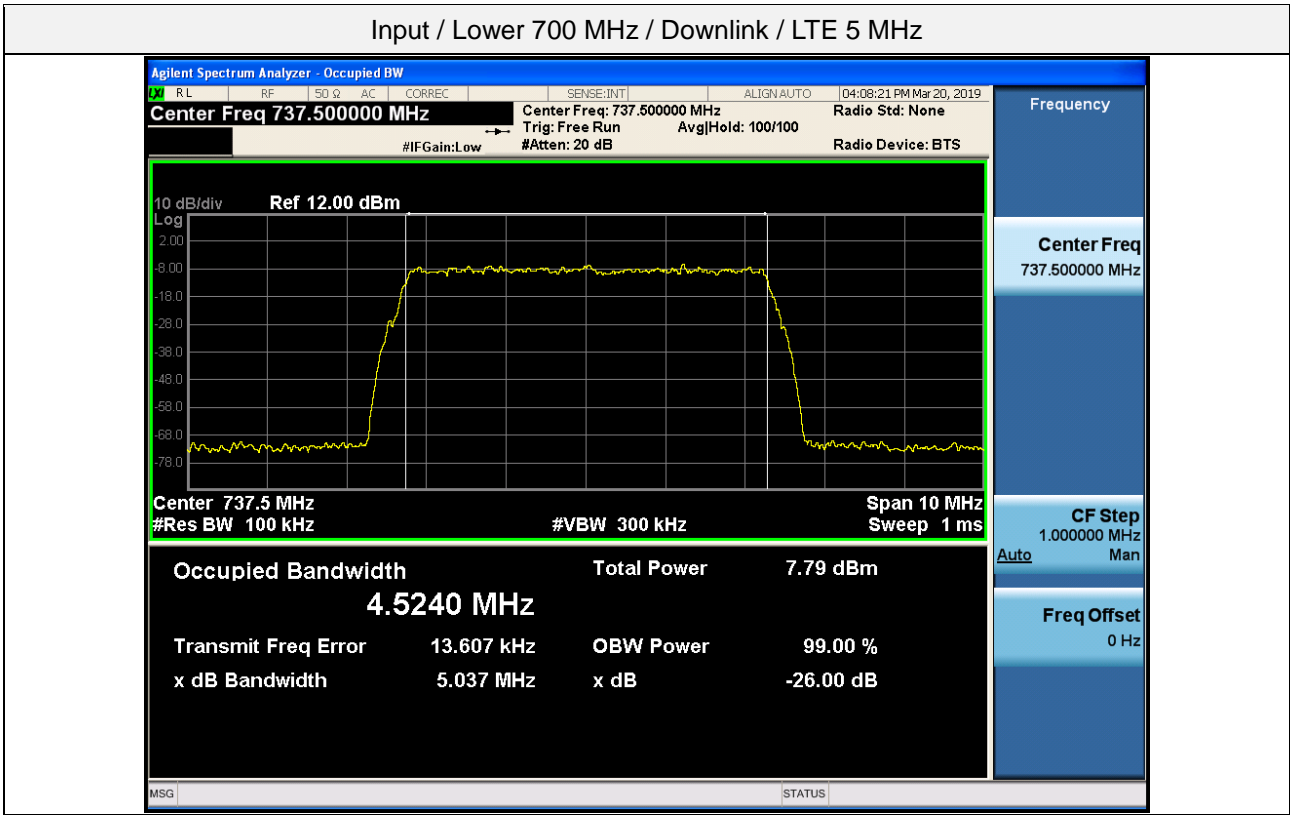

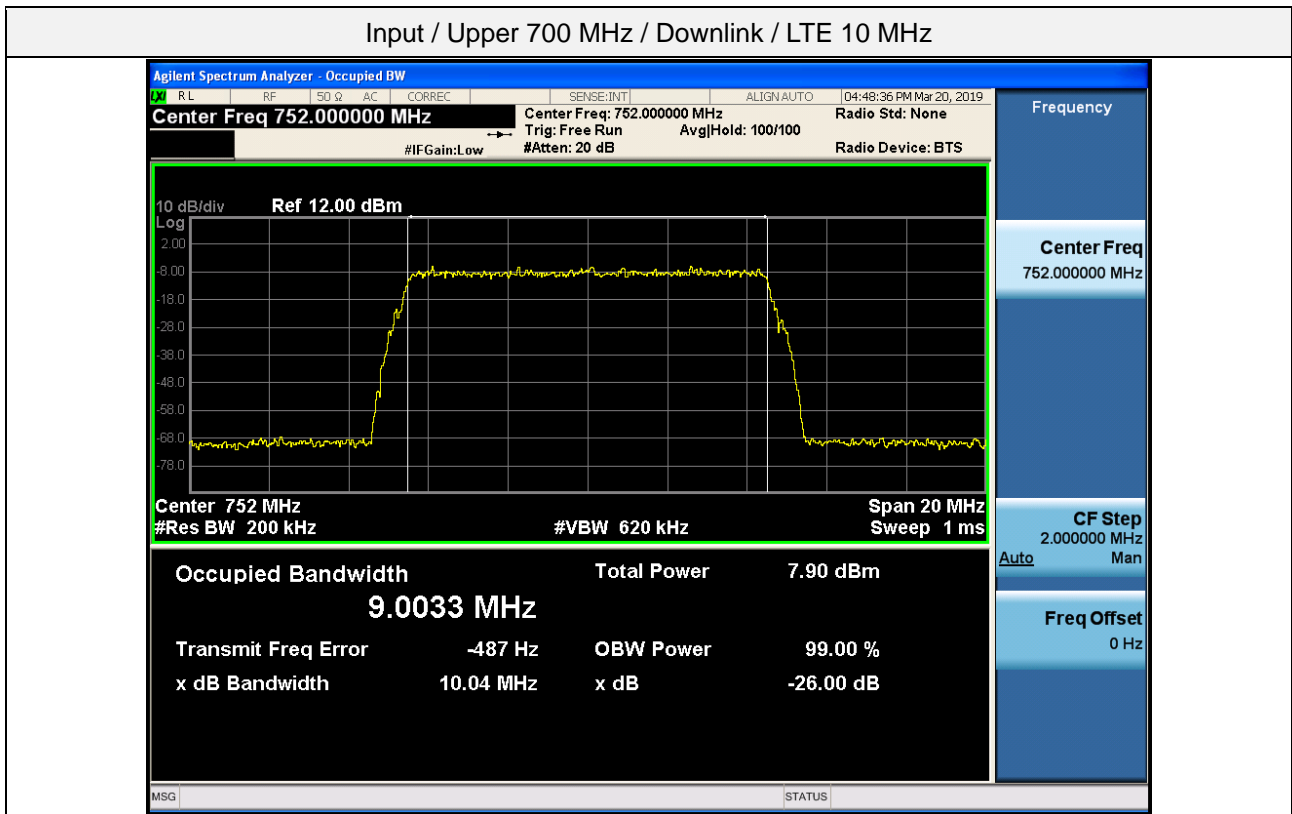
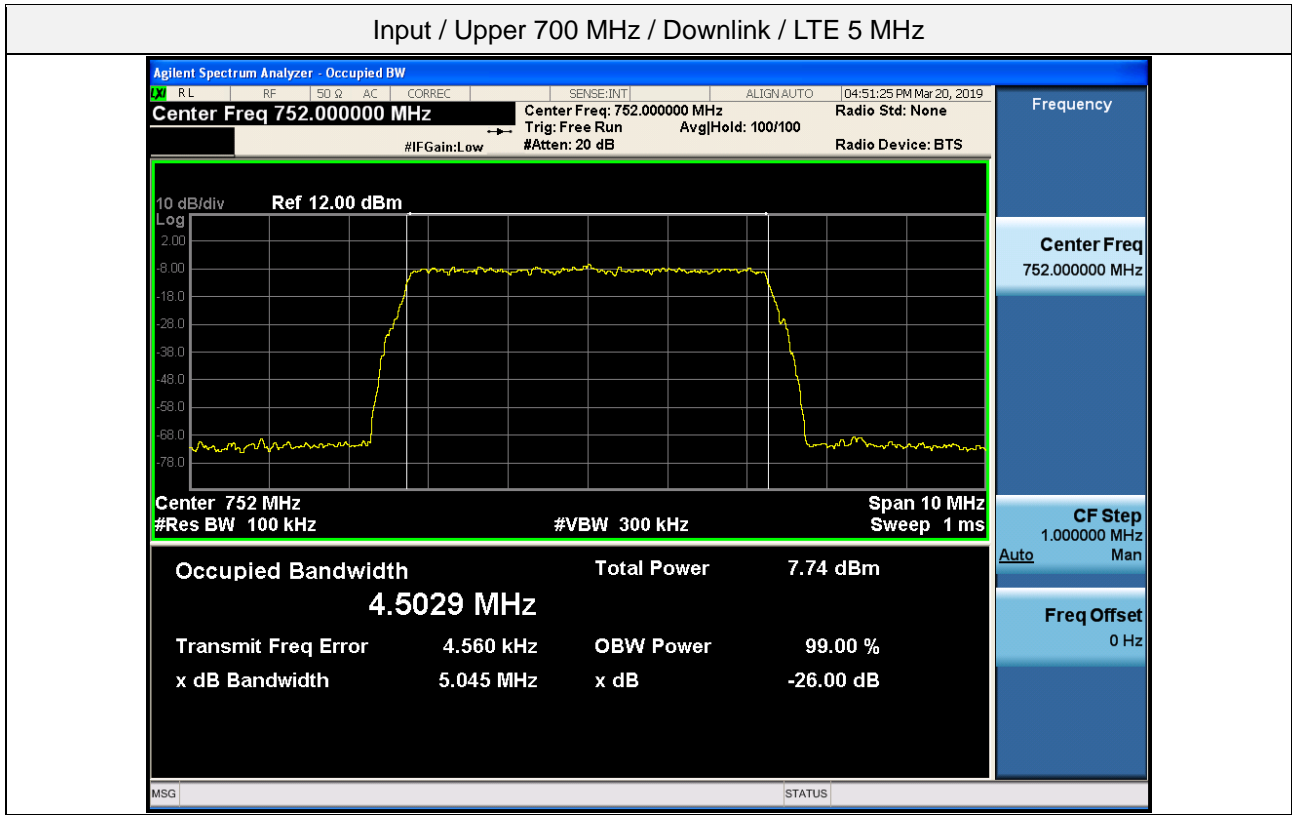



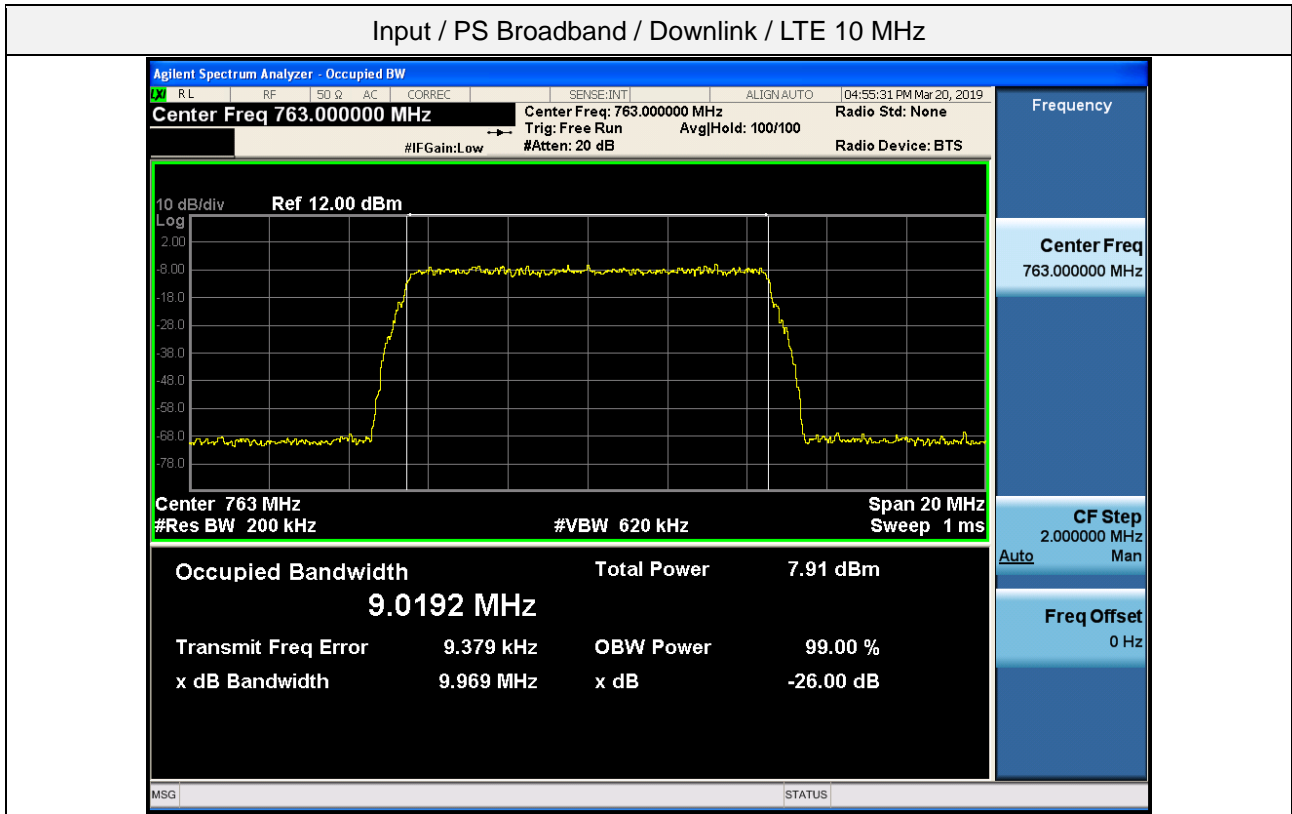
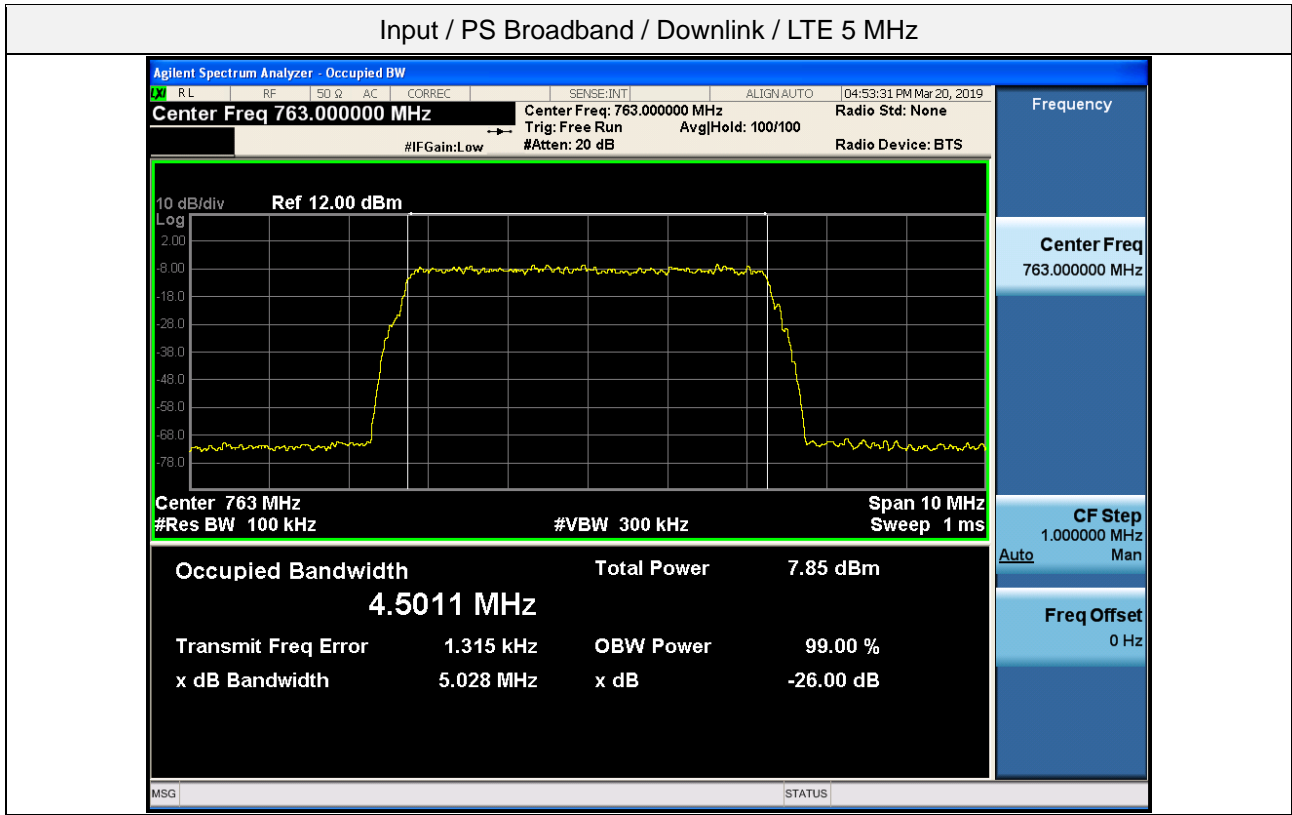

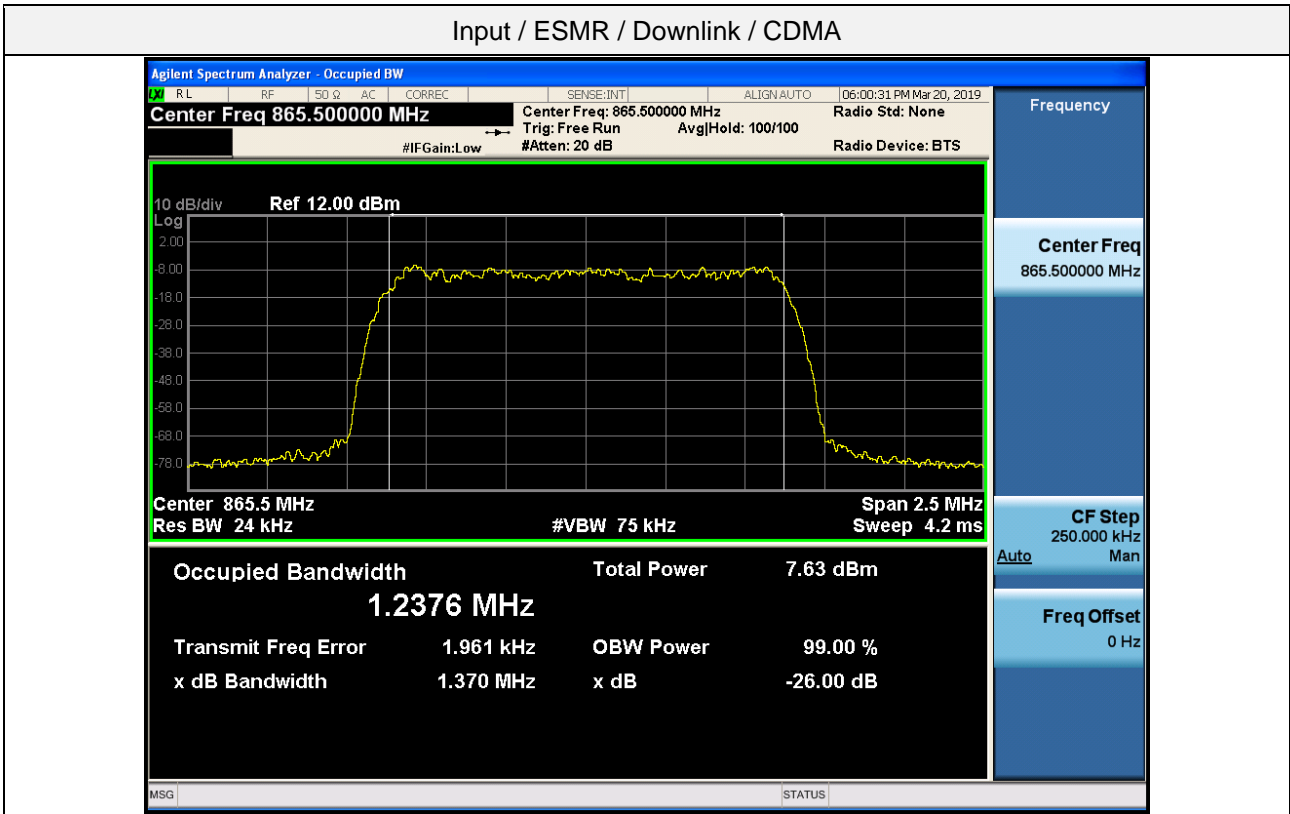
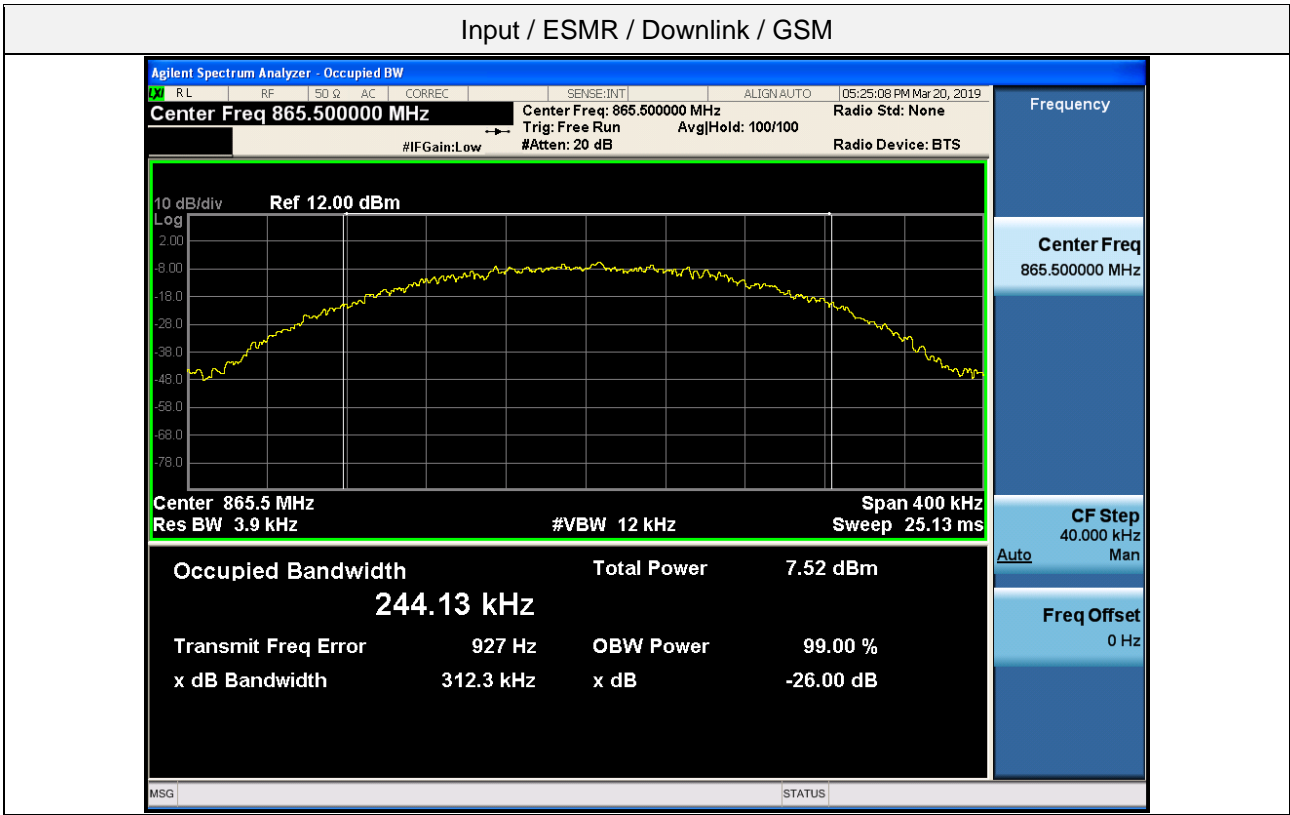

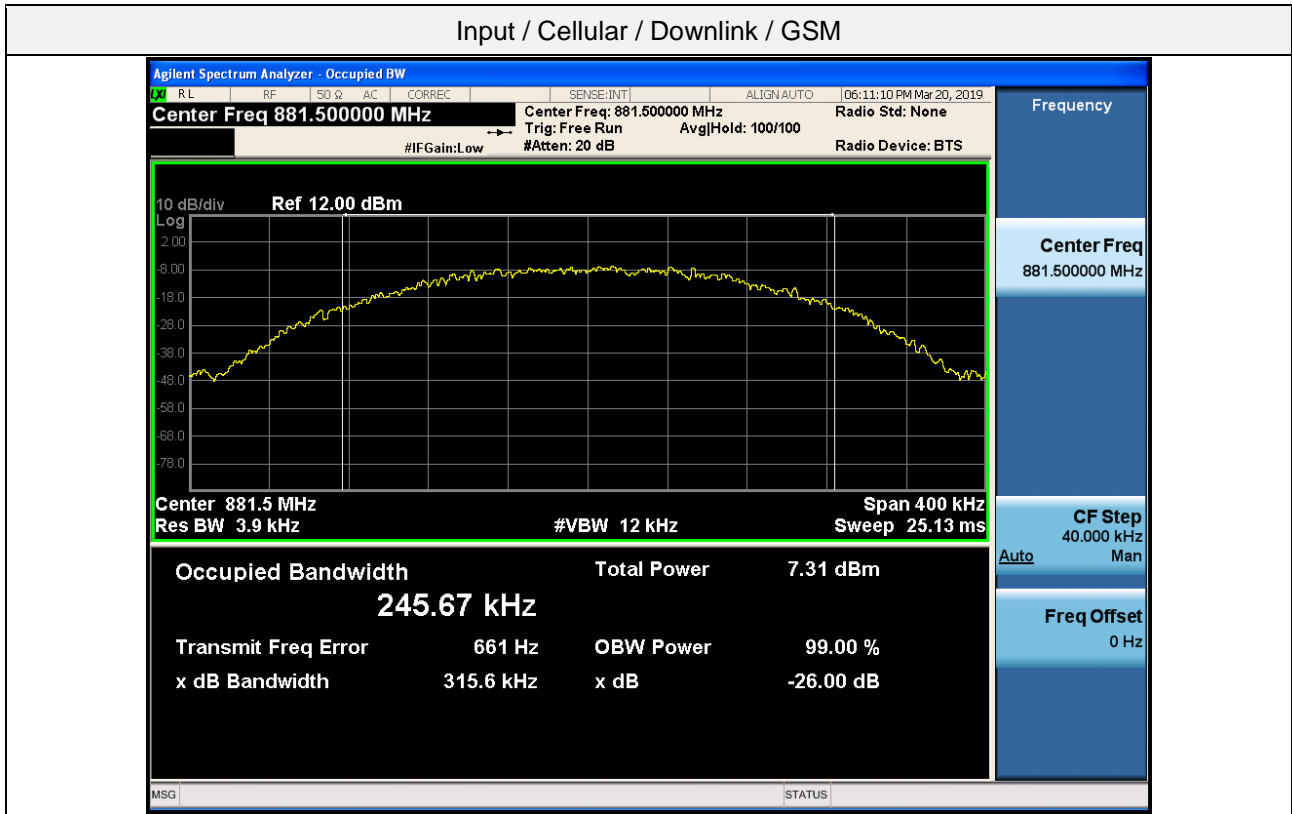
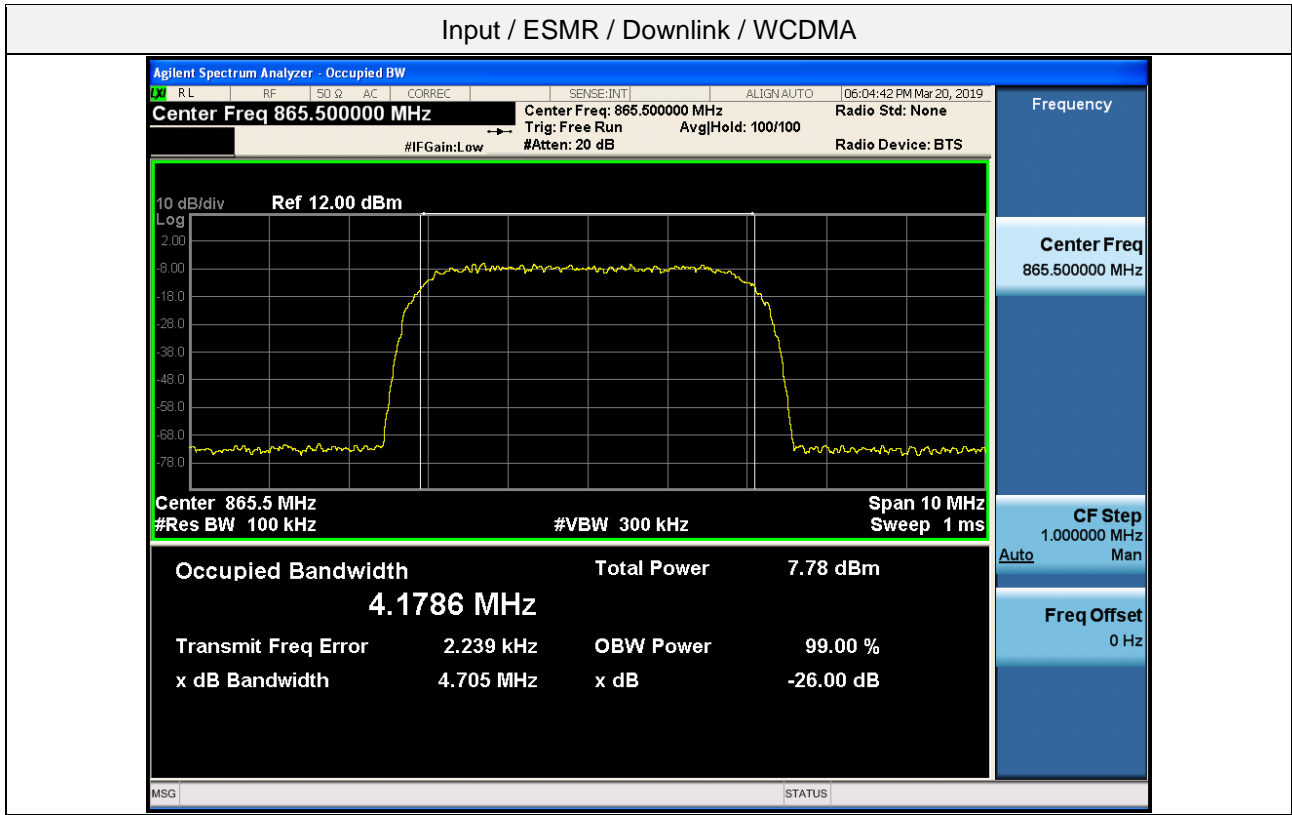

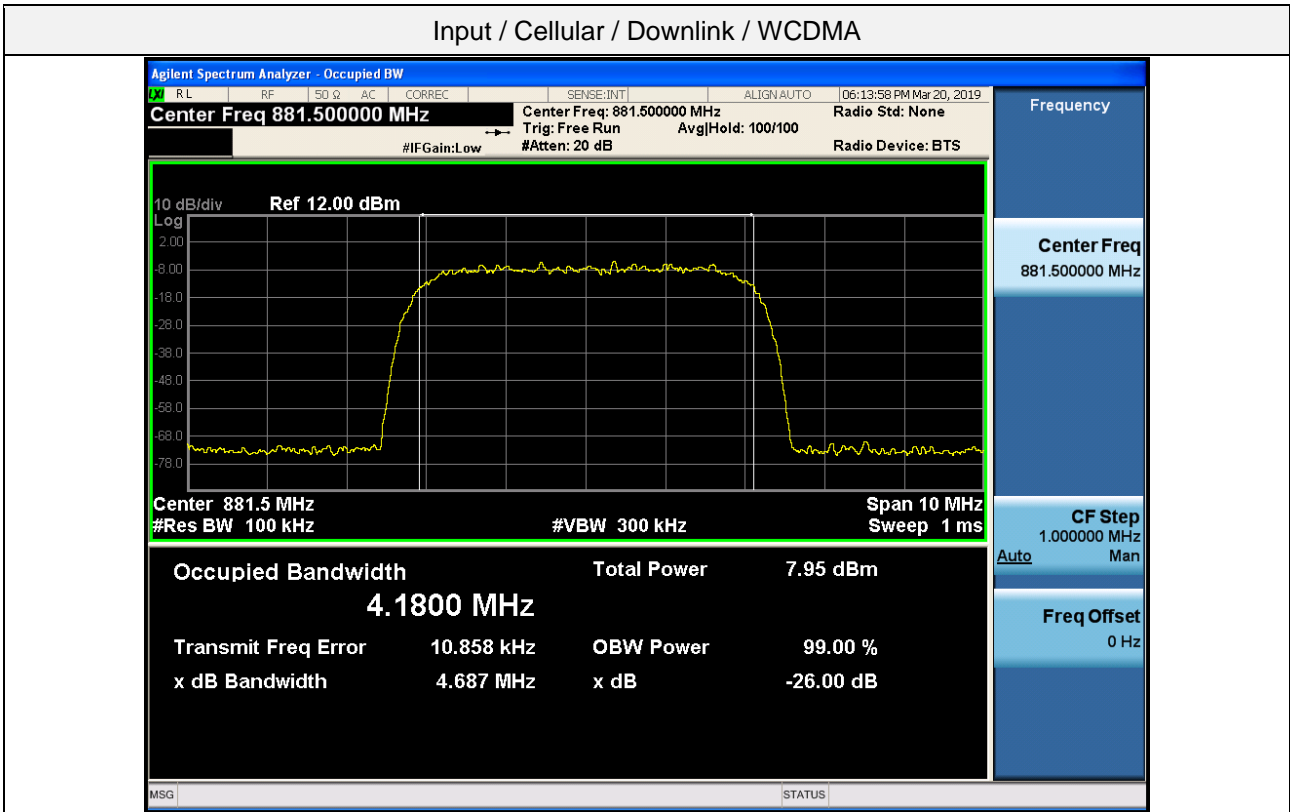
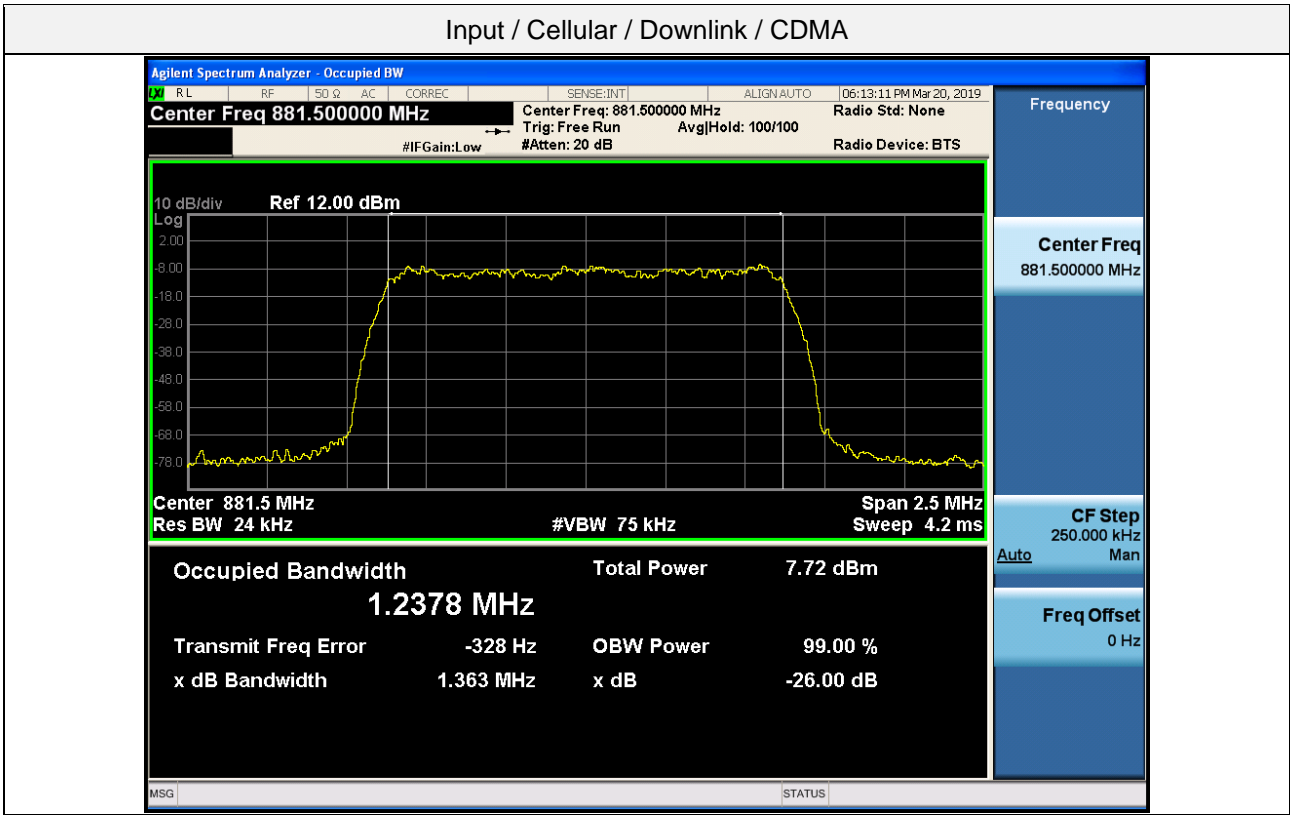

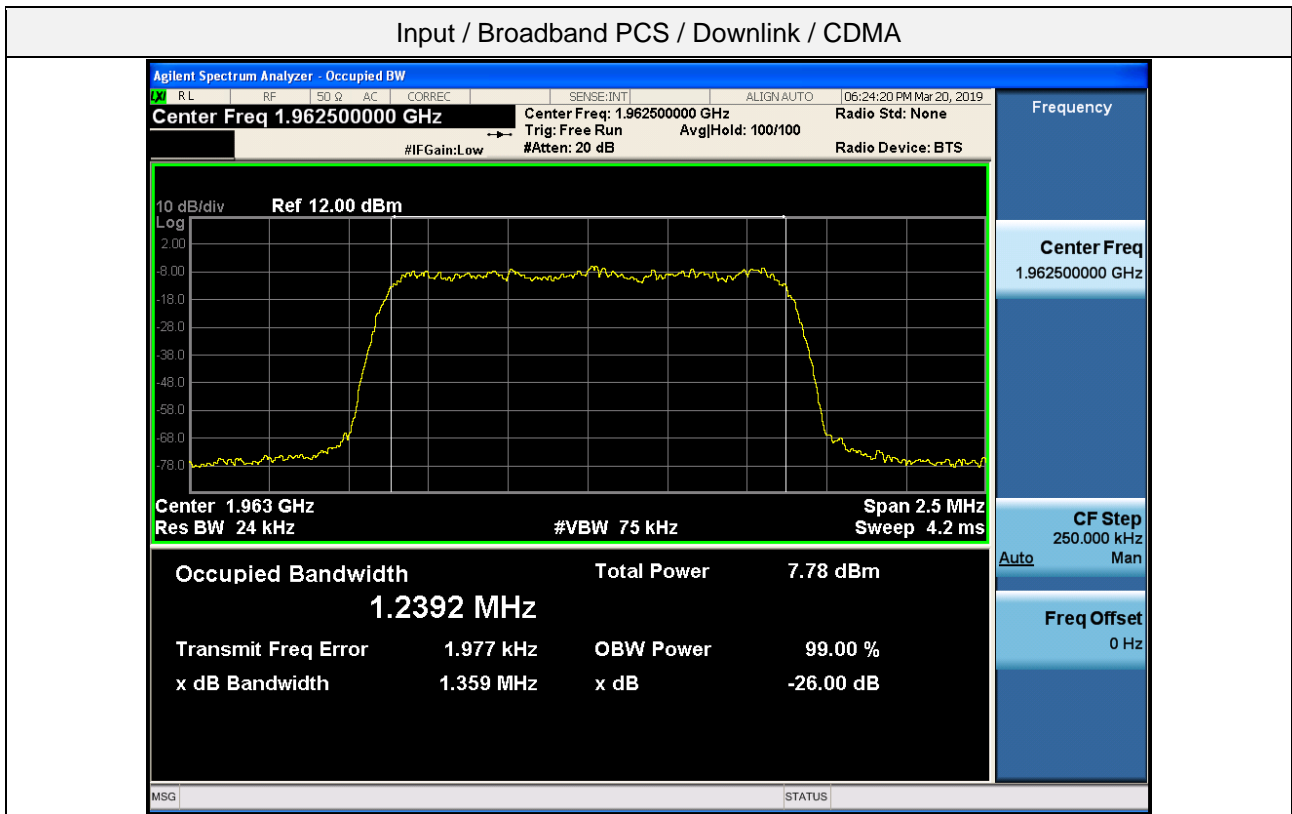
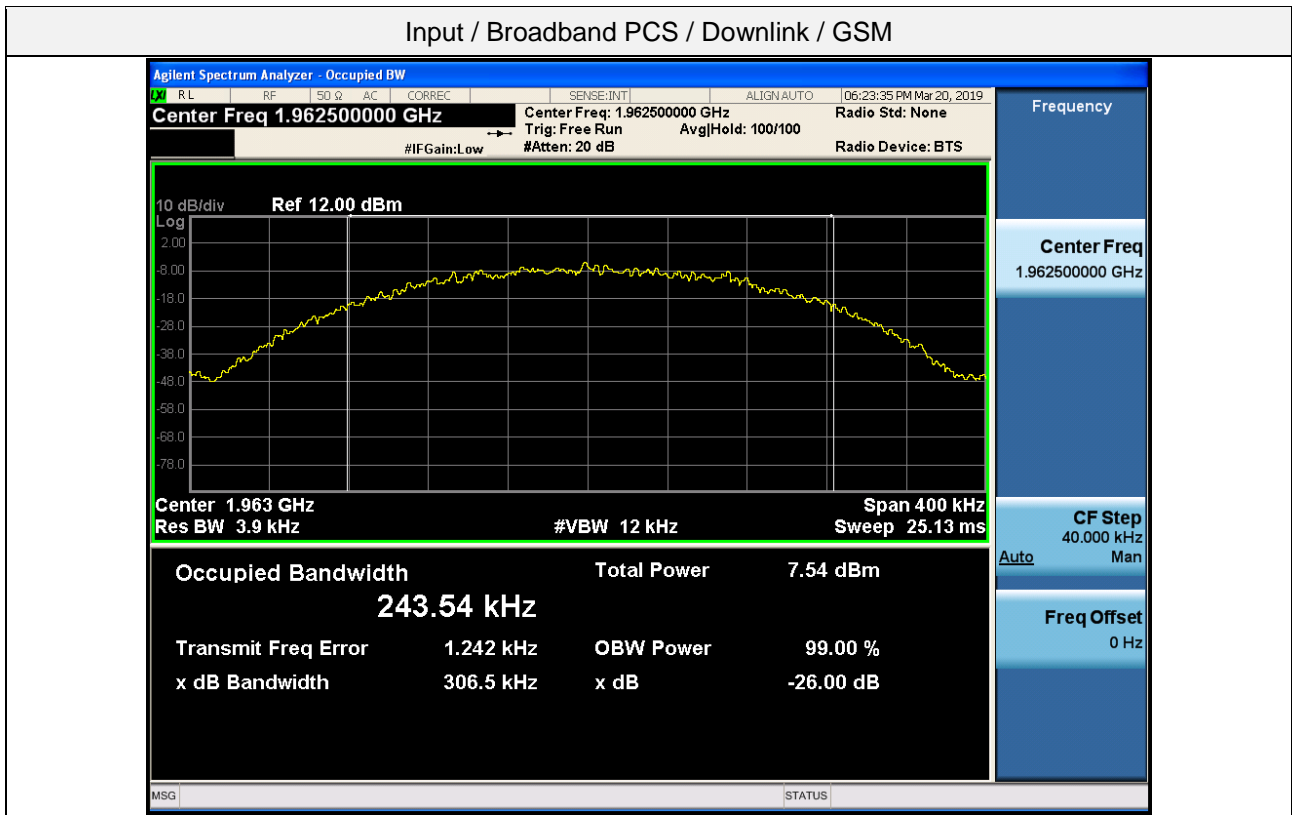

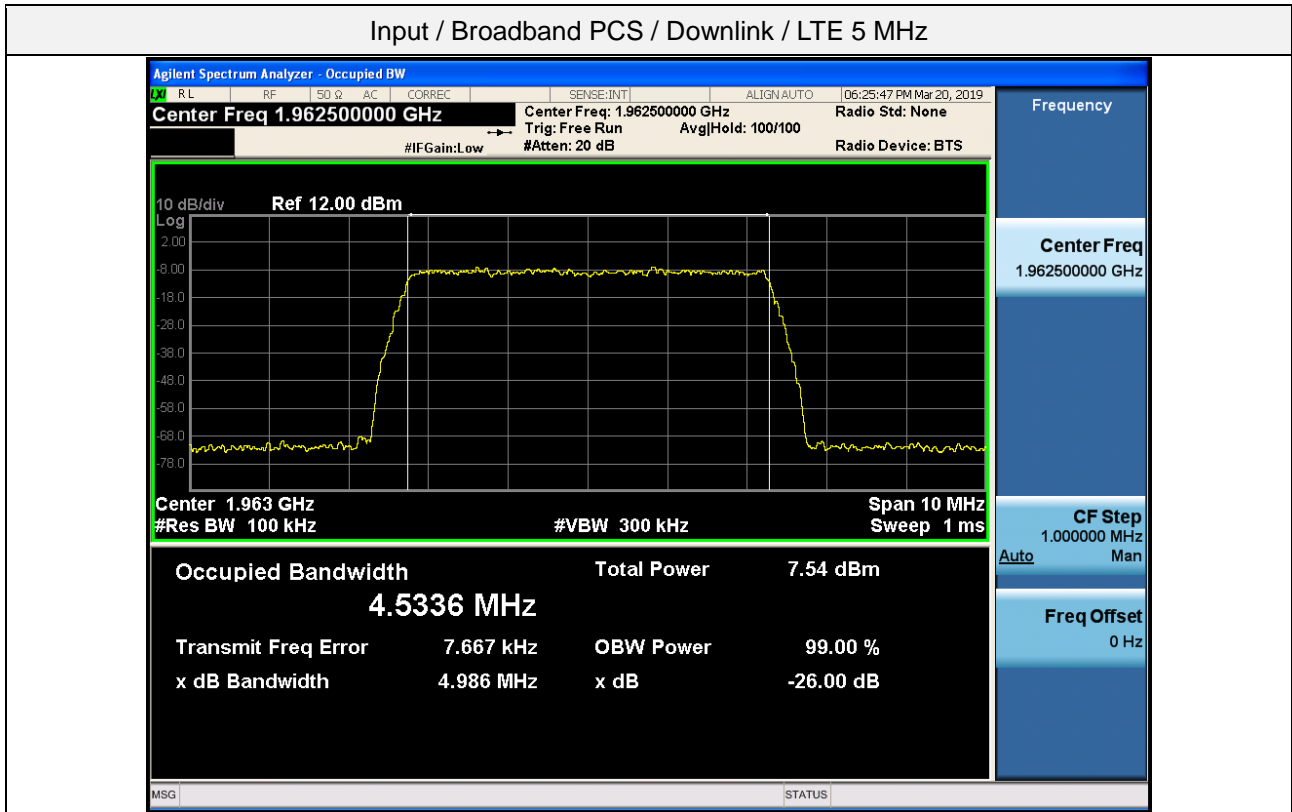
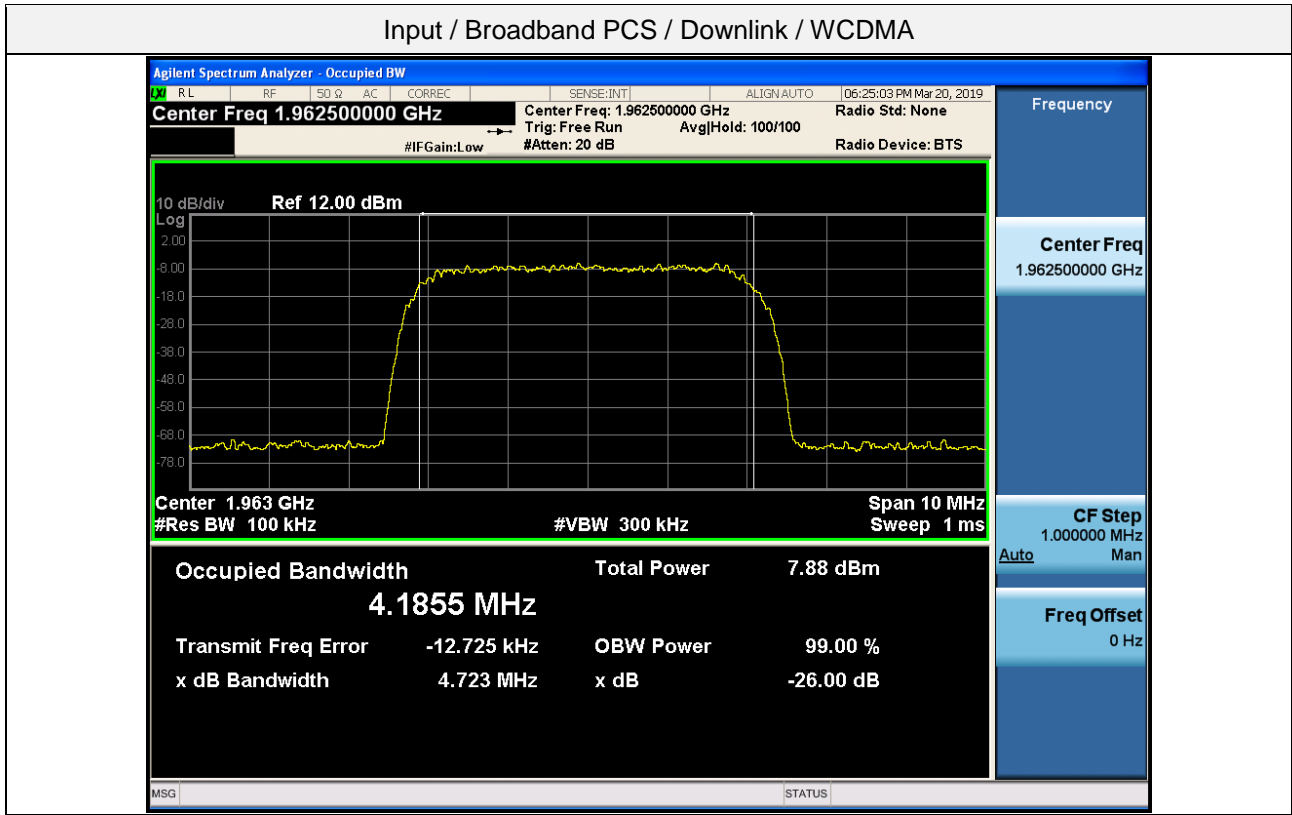

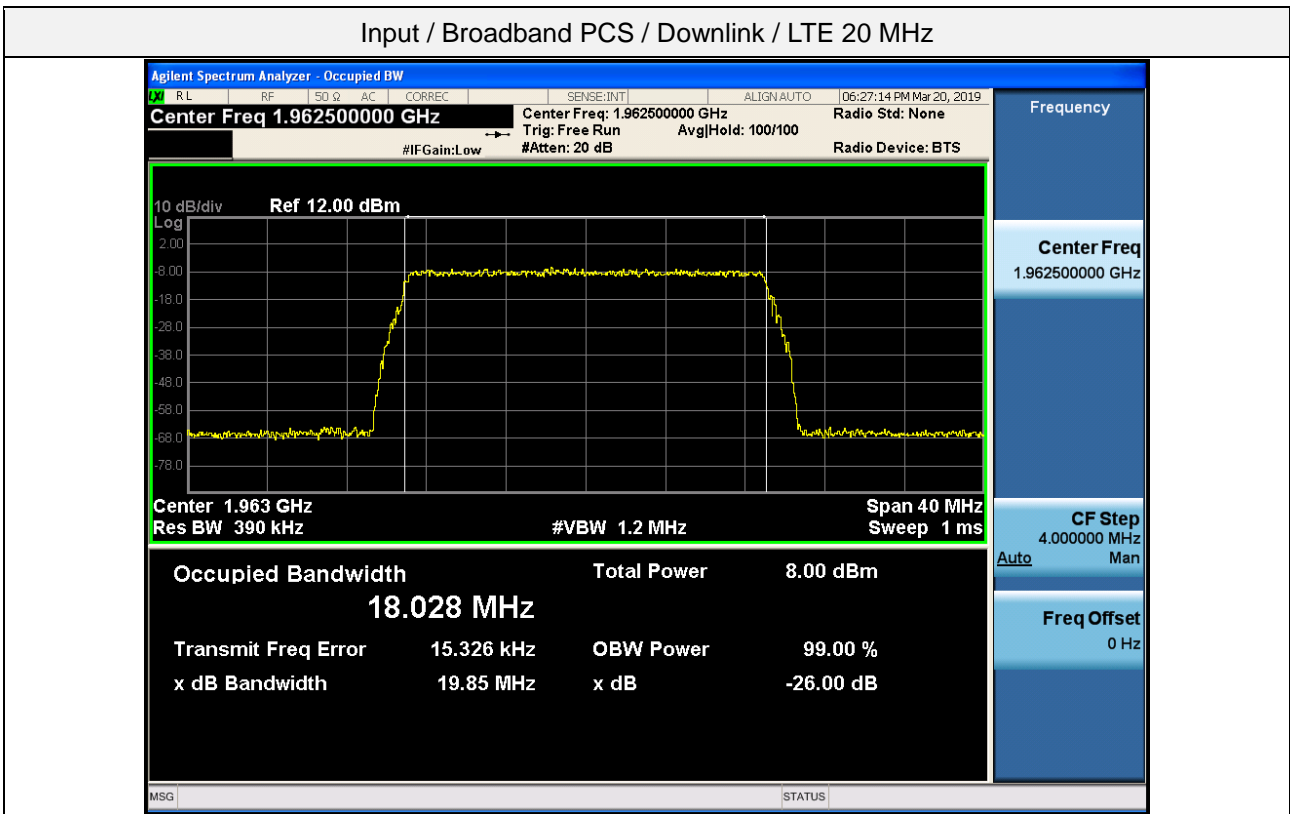
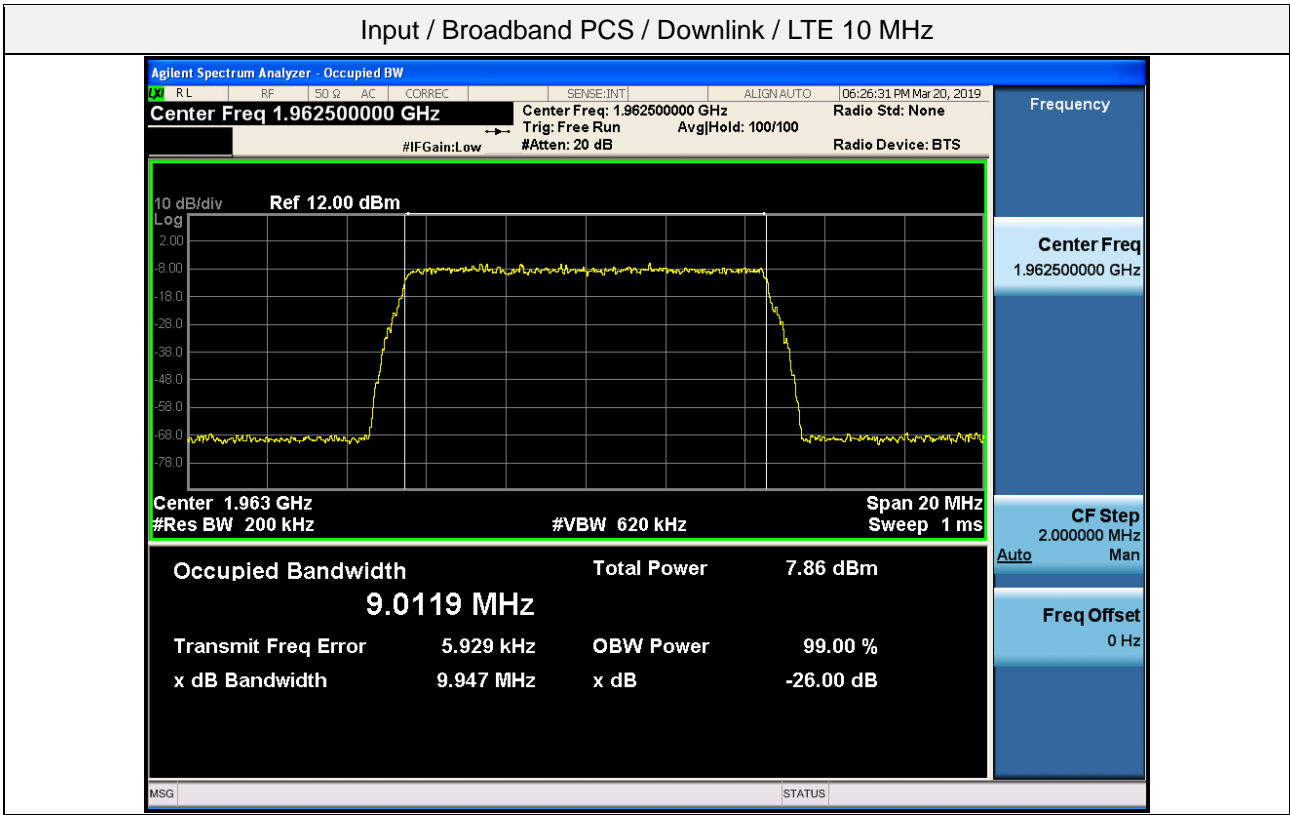

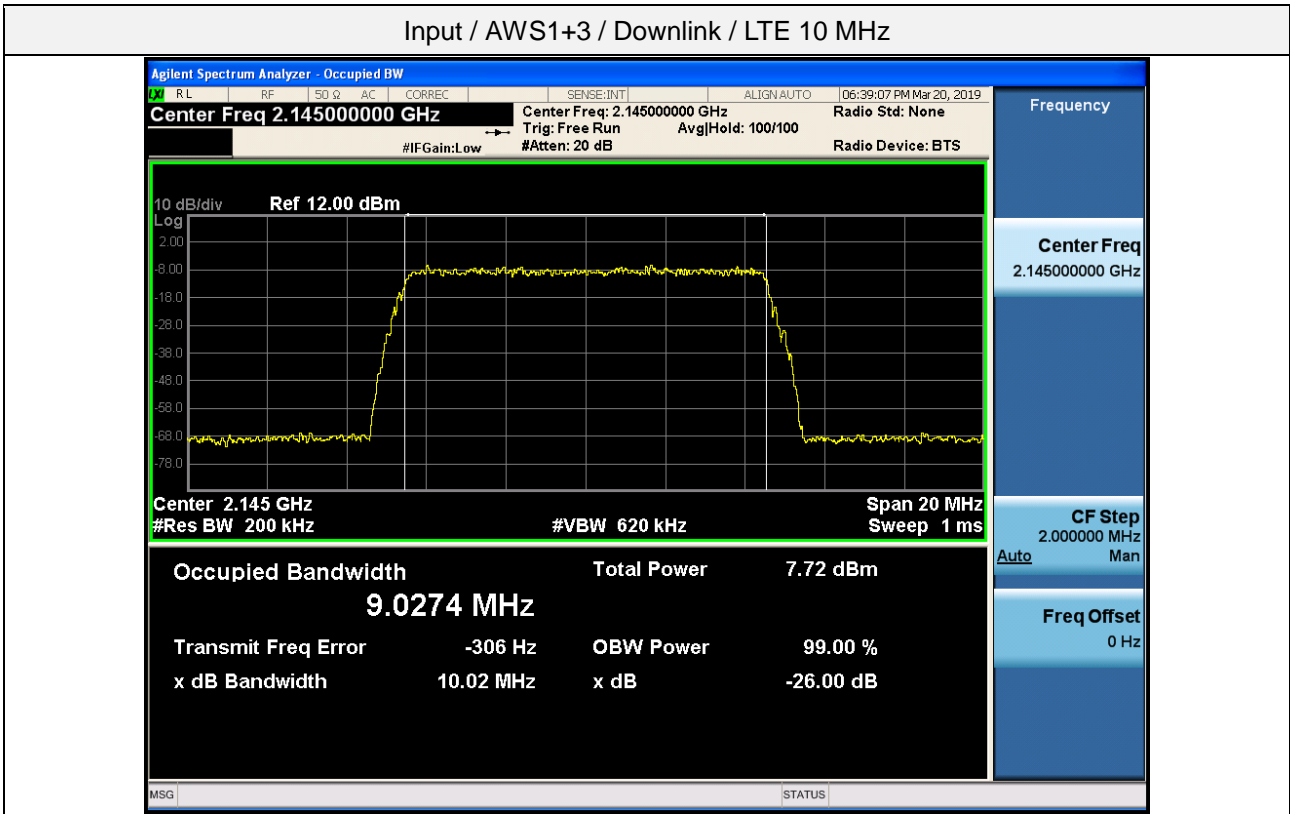
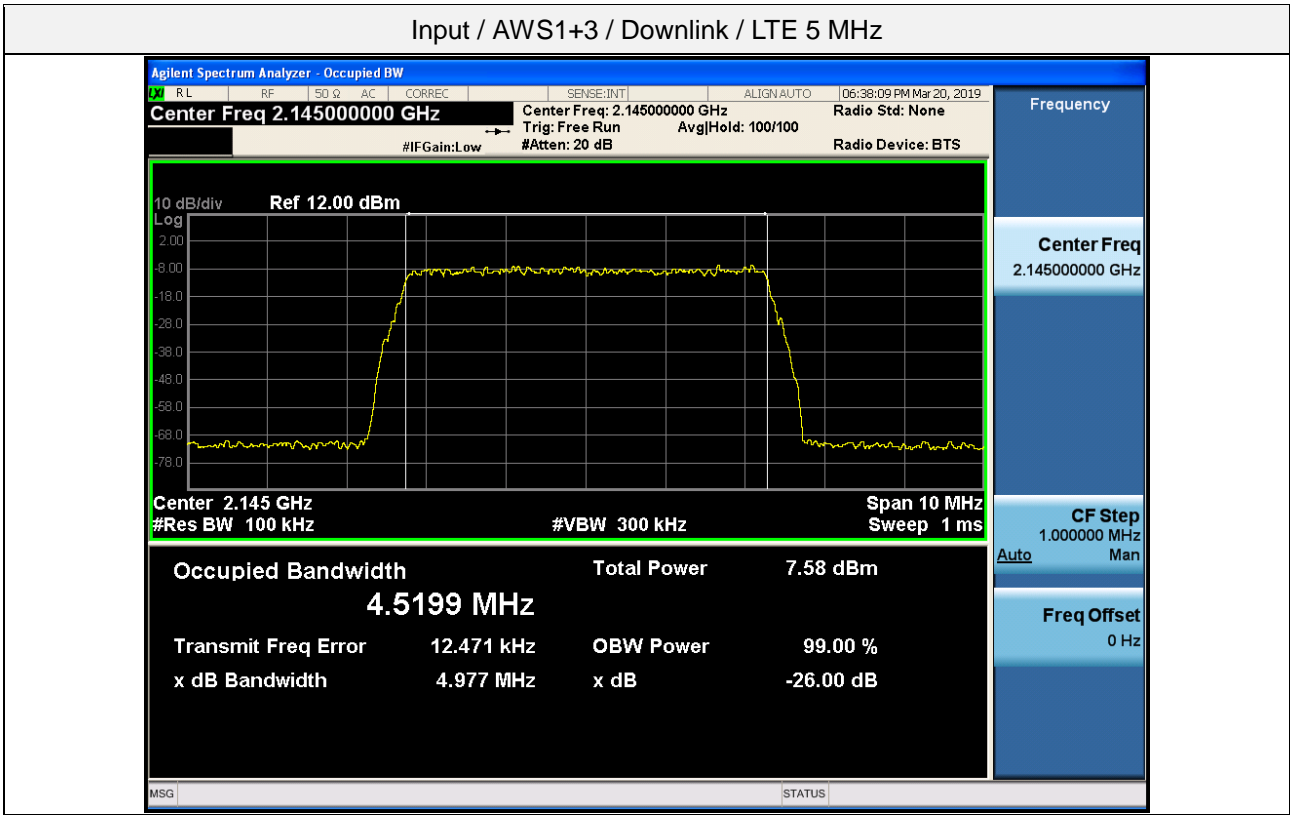



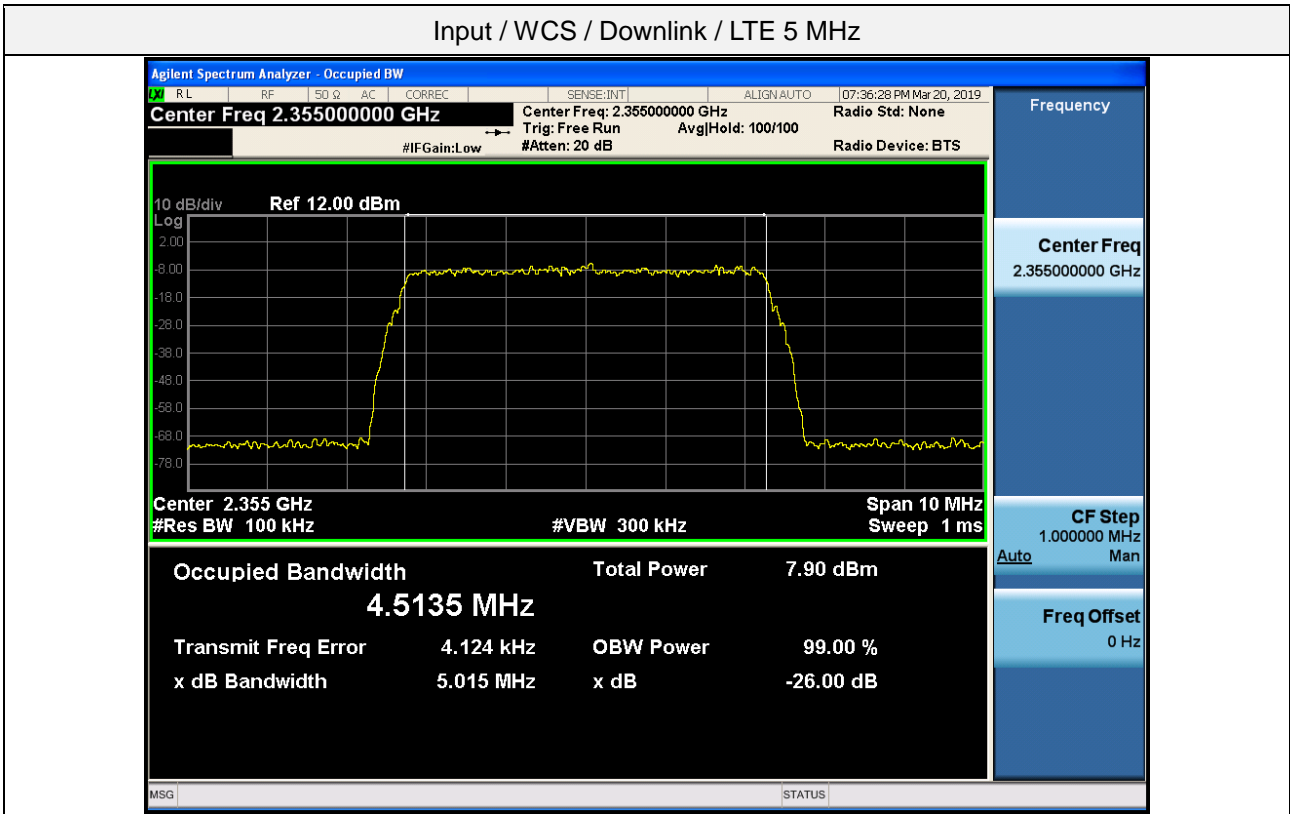
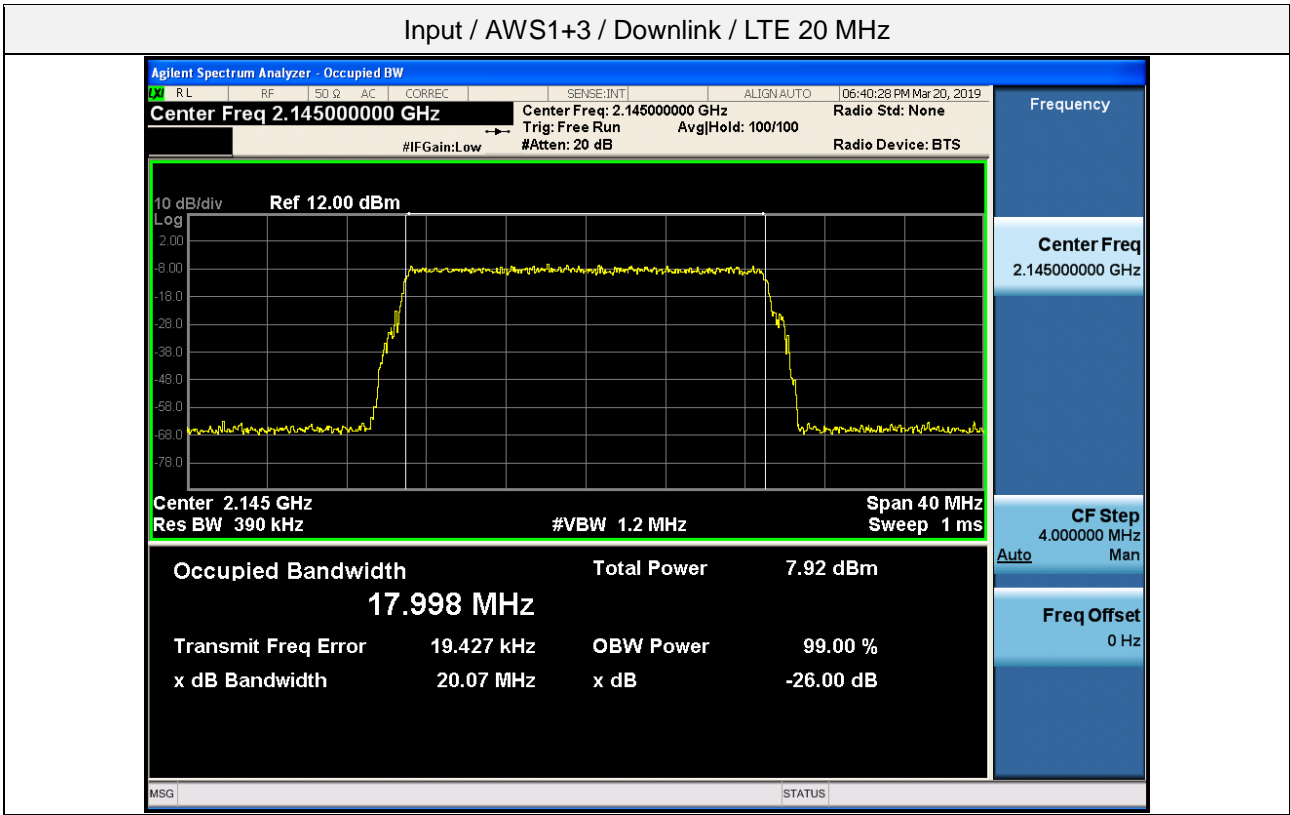

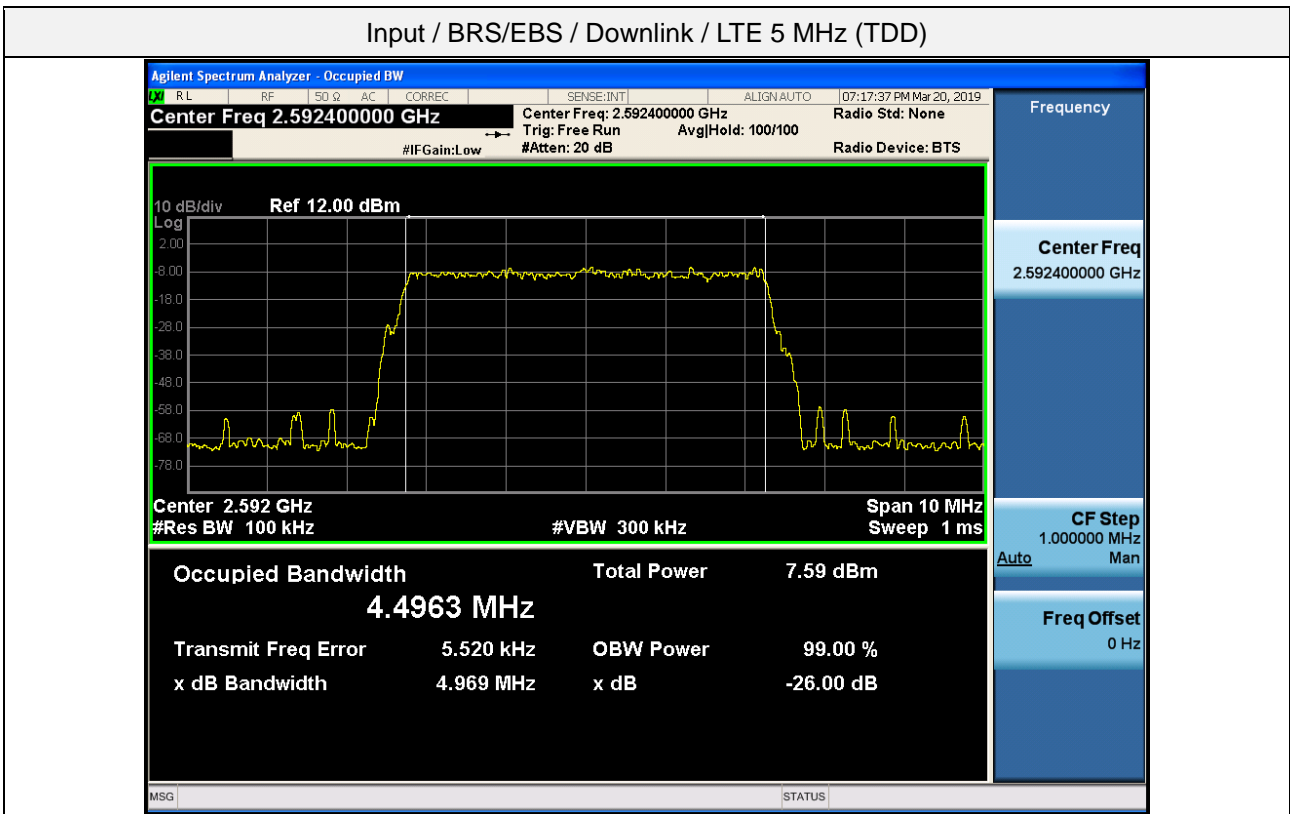
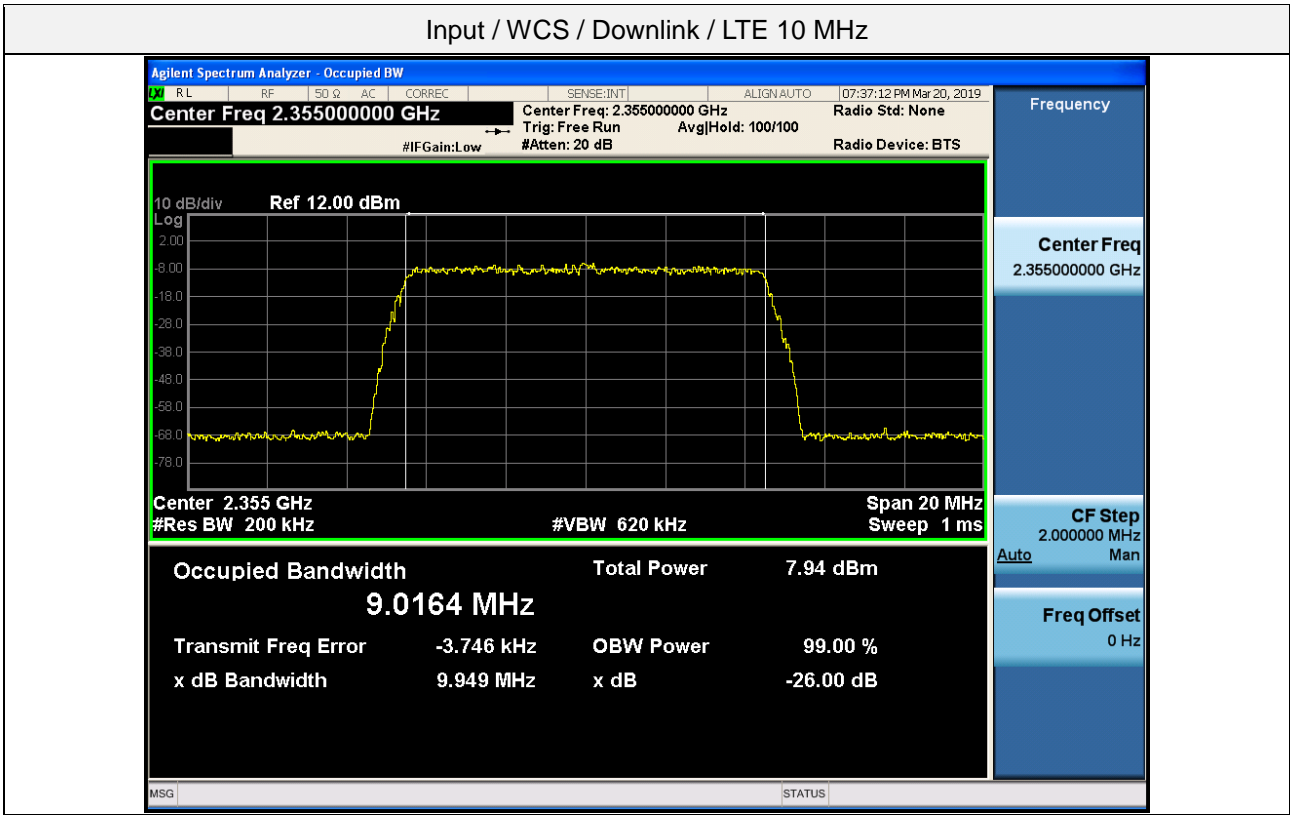

Input / BRS/EBS / Downlink / LTE 10 MHz (TDD)

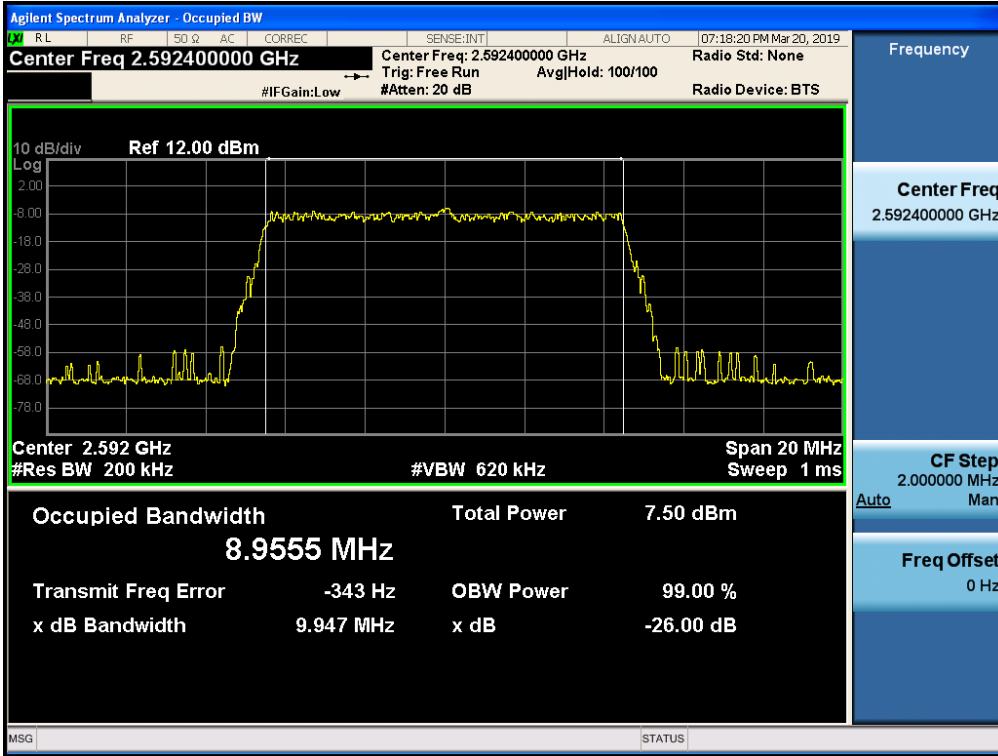

Input / BRS/EBS / Downlink / LTE 20 MHz (TDD)

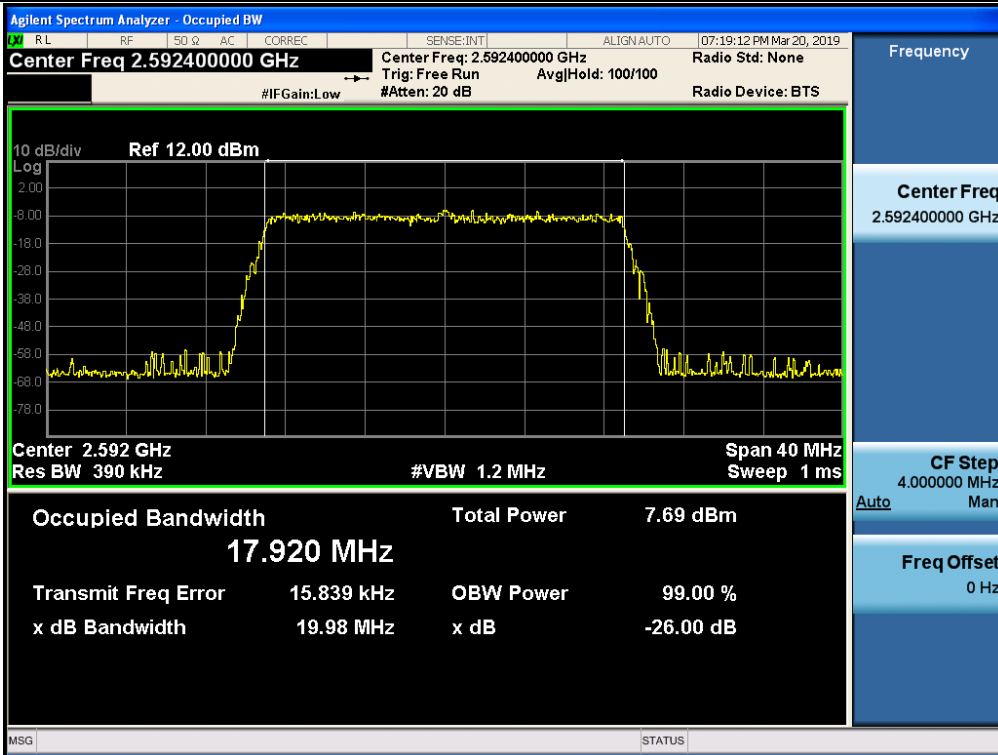

3 dB above the AGC threshold output / Lower 700 MHz / Downlink / LTE 5 MHz

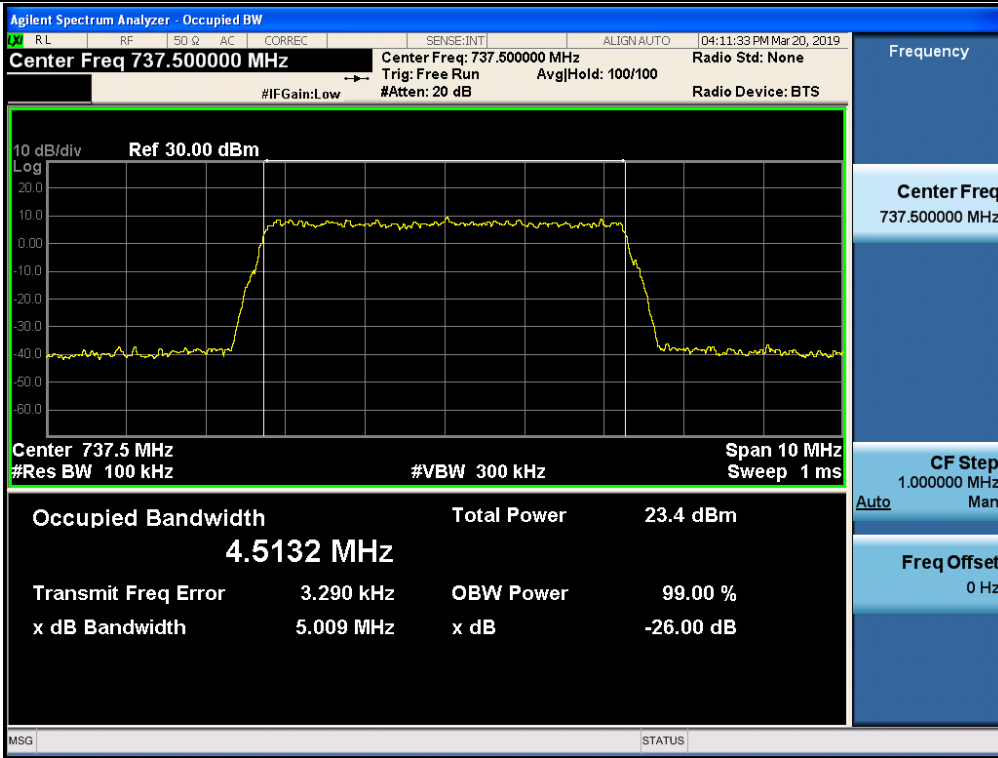

3 dB above the AGC threshold output / Lower 700 MHz / Downlink / LTE 10 MHz

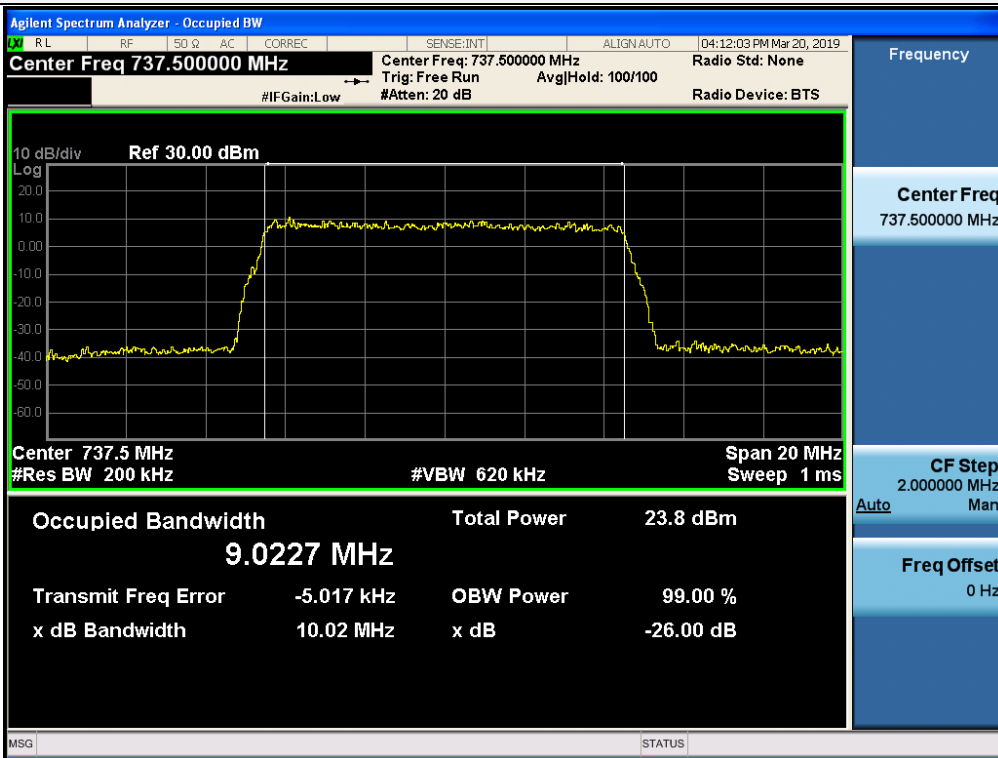

3 dB above the AGC threshold output / Upper 700 MHz / Downlink / LTE 5 MHz

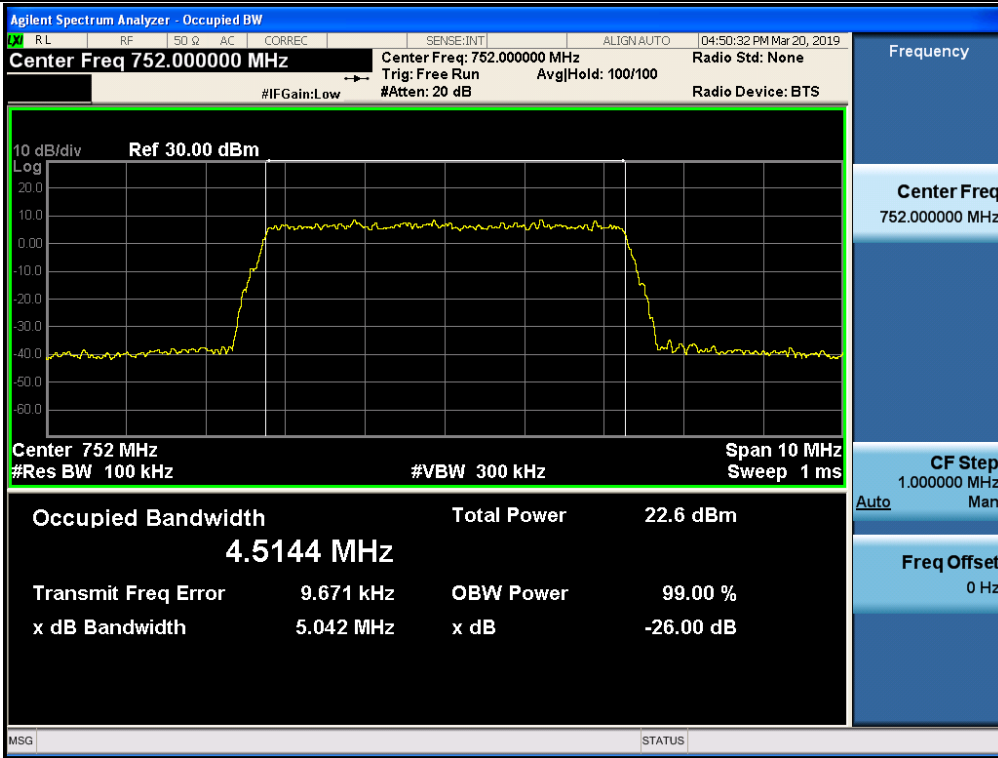

3 dB above the AGC threshold output / Upper 700 MHz / Downlink / LTE 10 MHz

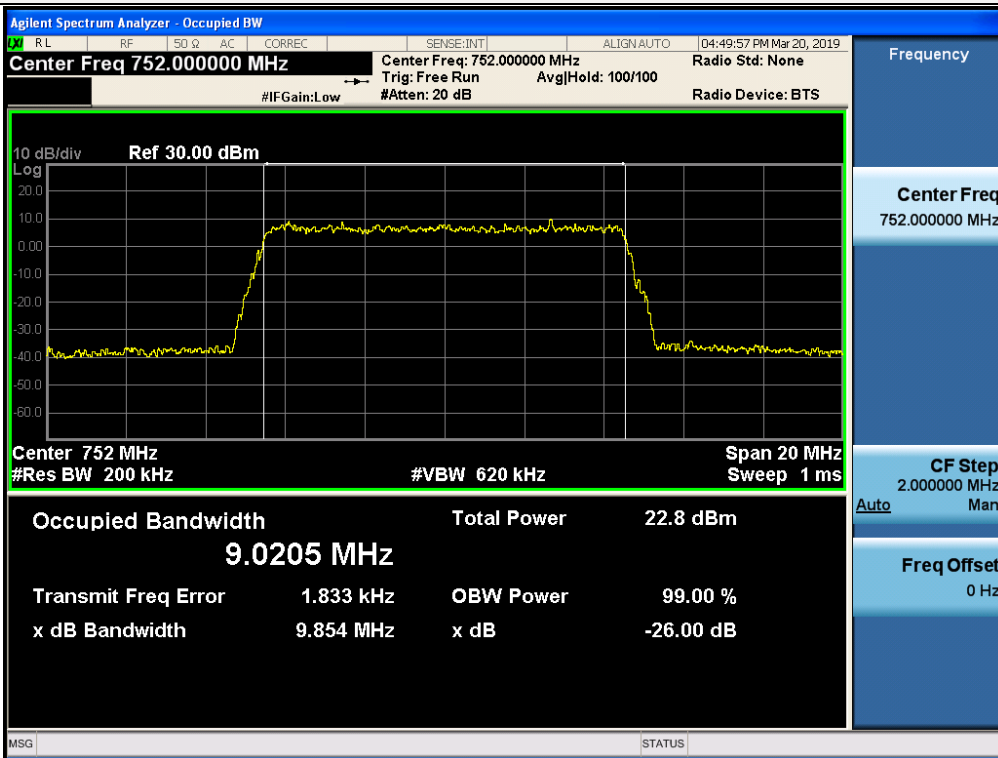

3 dB above the AGC threshold output / PS Broadband / Downlink / LTE 5 MHz

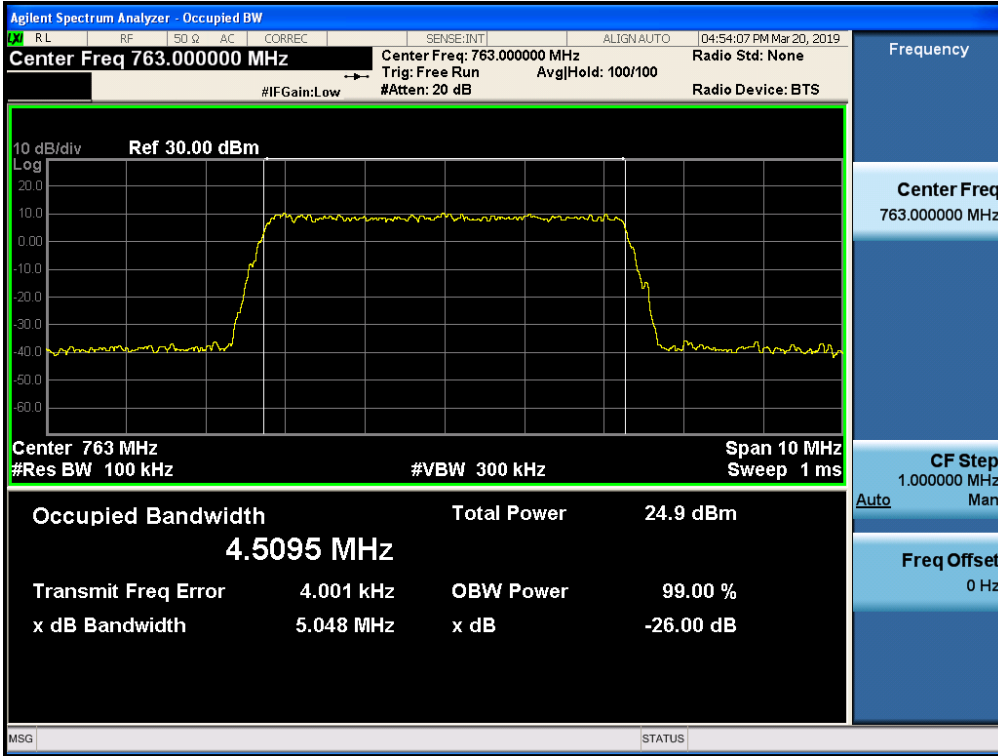

3 dB above the AGC threshold output / PS Broadband / Downlink / LTE 10 MHz

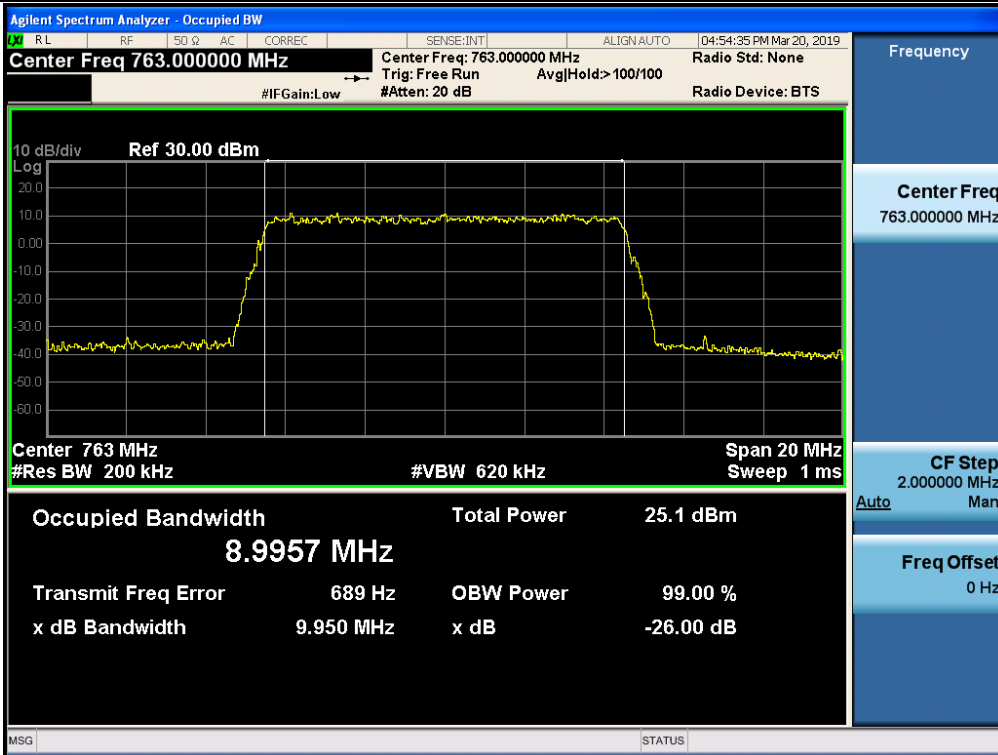

3 dB above the AGC threshold output / ESMR / Downlink / GSM

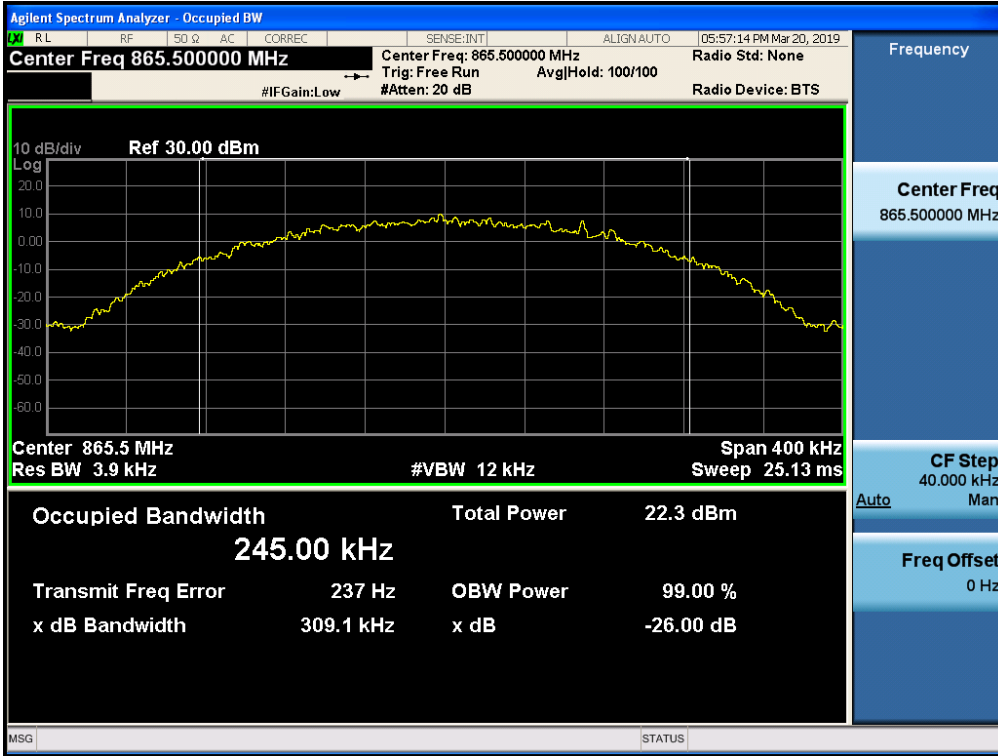

3 dB above the AGC threshold output / ESMR / Downlink / CDMA

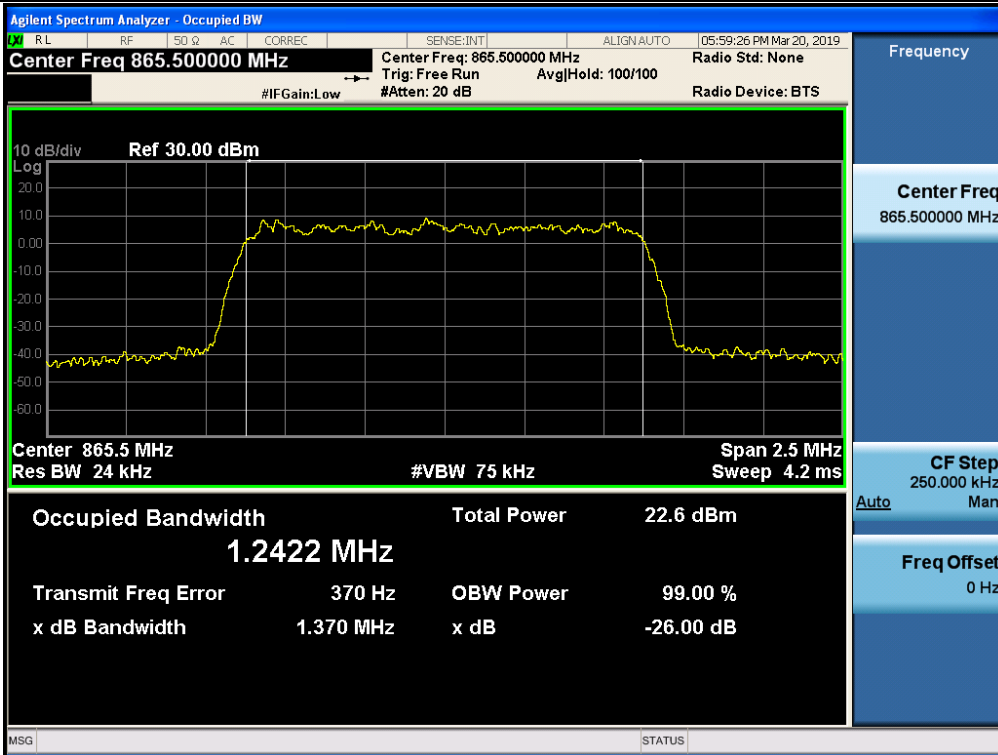

3 dB above the AGC threshold output / ESMR / Downlink / WCDMA

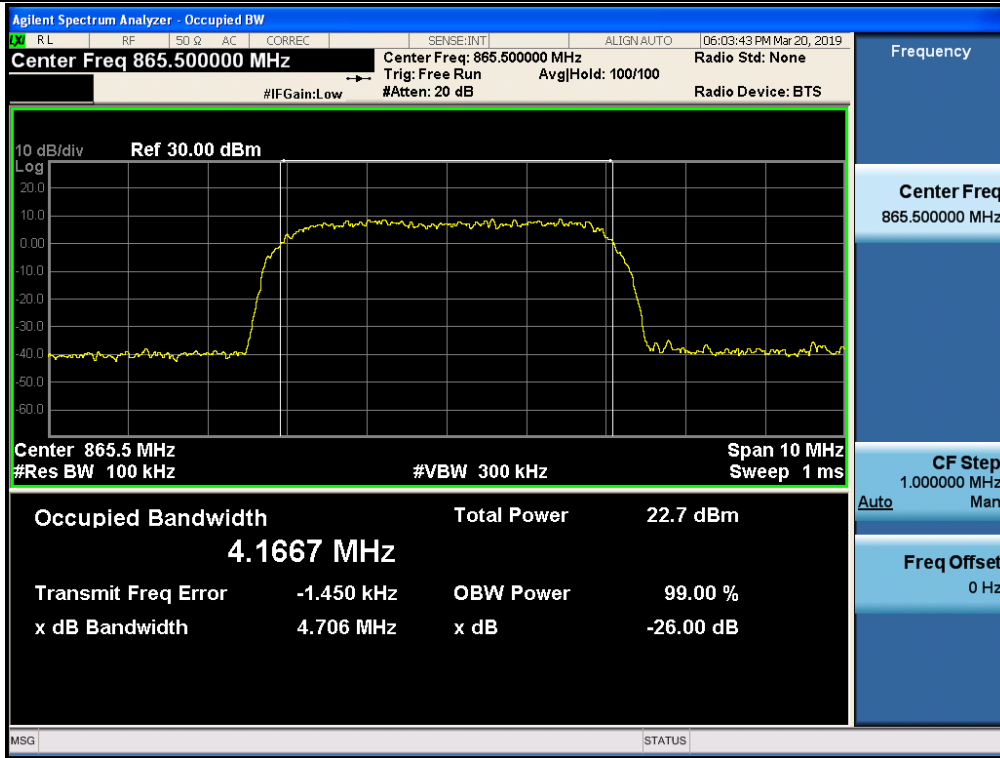

3 dB above the AGC threshold output / Cellular / Downlink / GSM

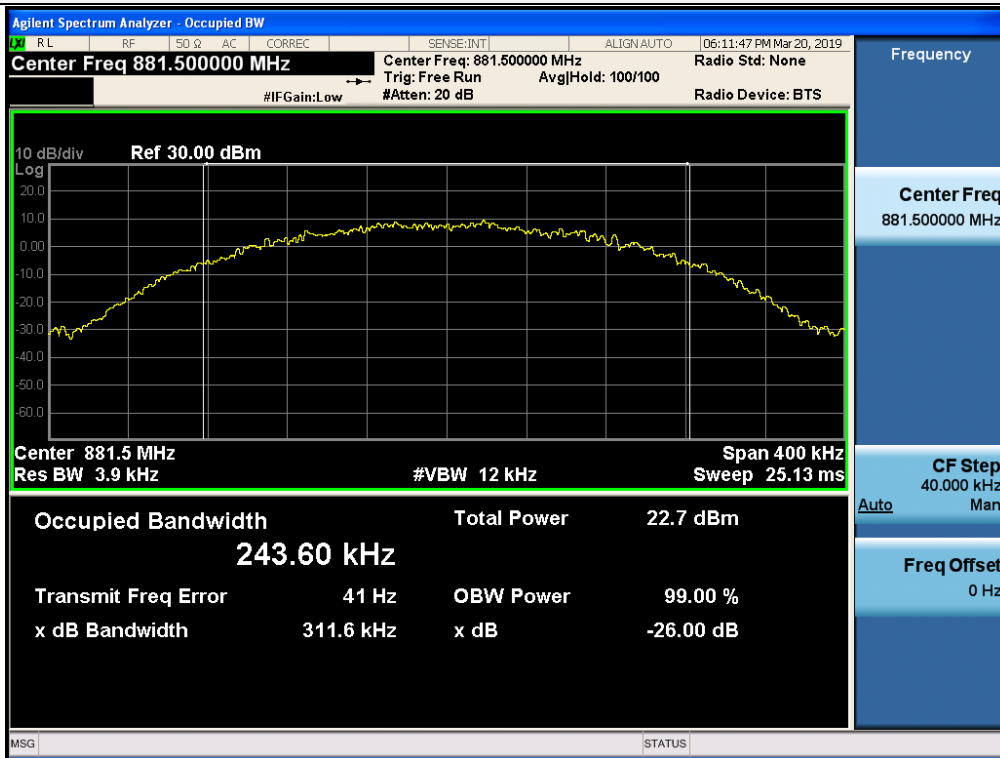



3 dB above the AGC threshold output / Cellular / Downlink / CDMA

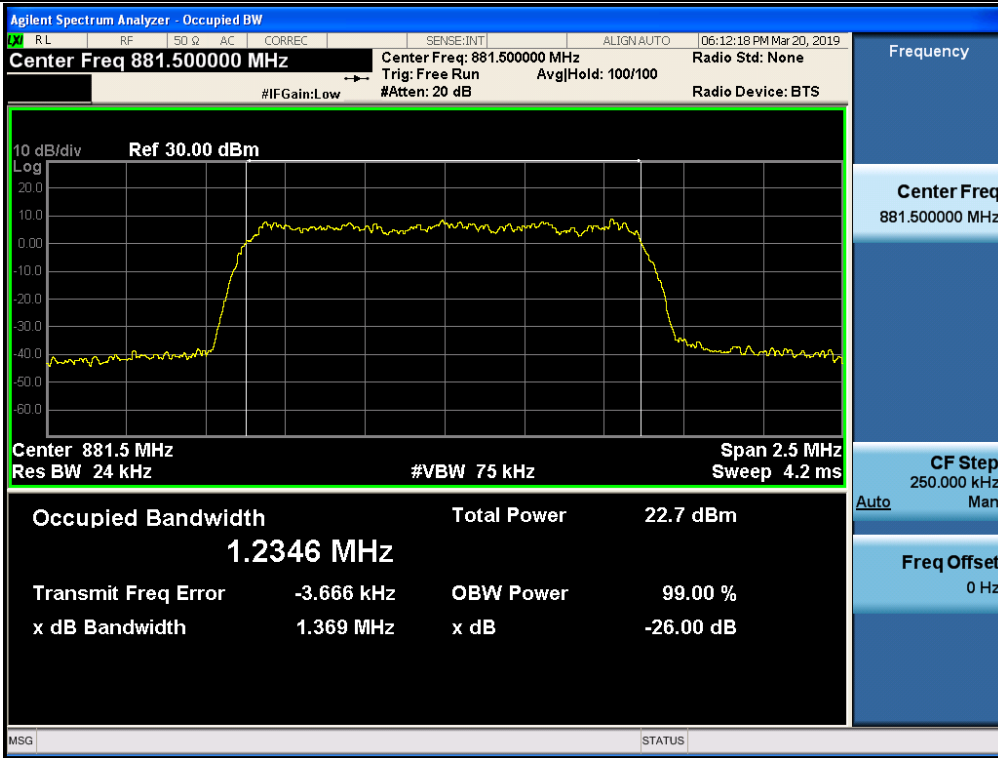

3 dB above the AGC threshold output / Cellular / Downlink / WCDMA

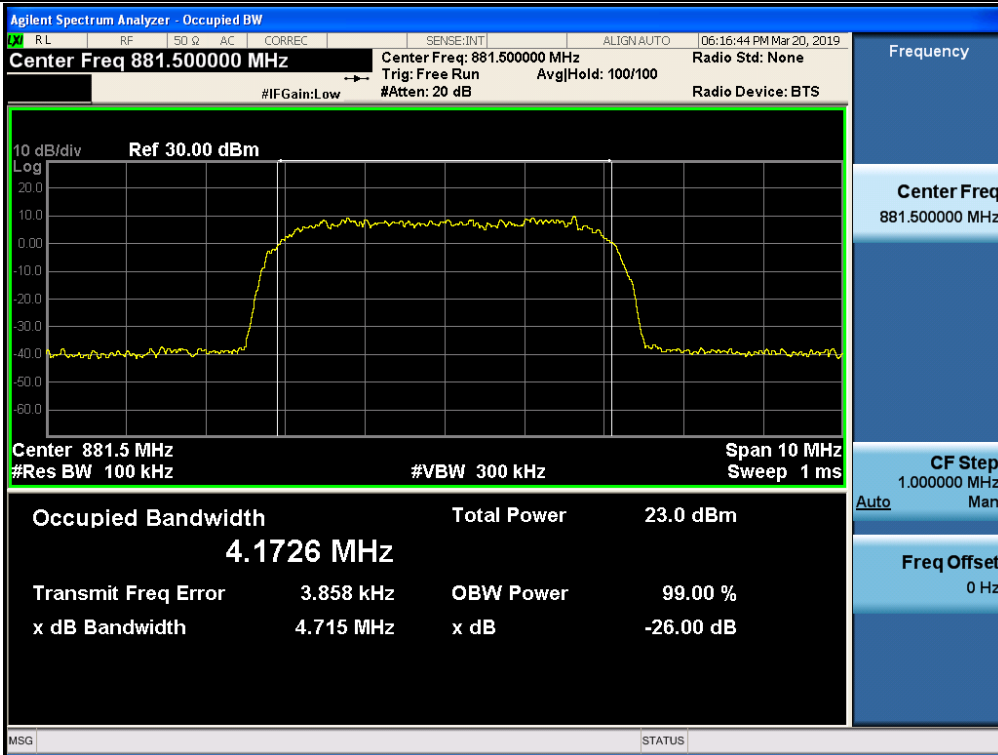

3 dB above the AGC threshold output / Broadband PCS / Downlink / GSM



3 dB above the AGC threshold output / Broadband PCS / Downlink / CDMA

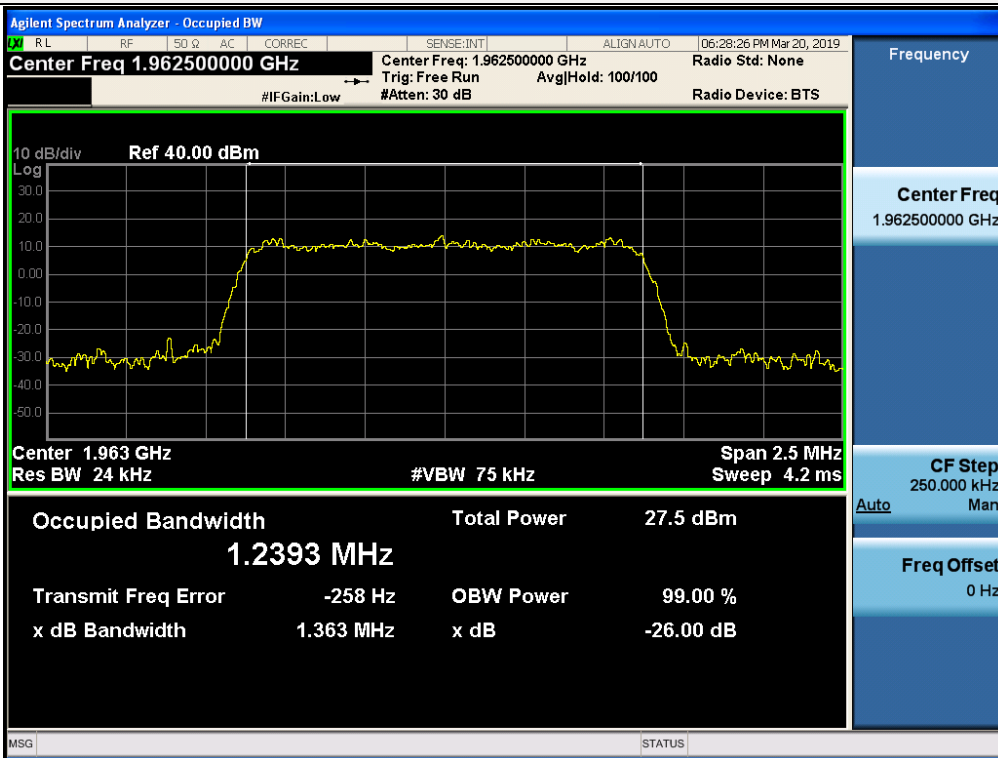

3 dB above the AGC threshold output / Broadband PCS / Downlink / WCDMA

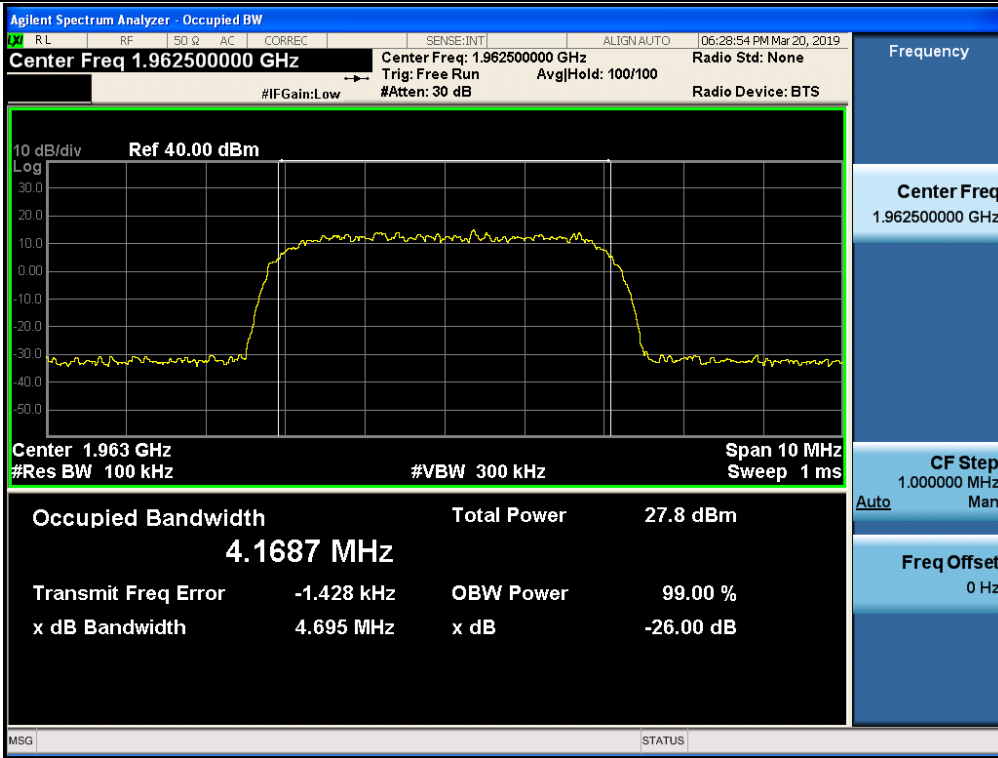

3 dB above the AGC threshold output / Broadband PCS / Downlink / LTE 5 MHz

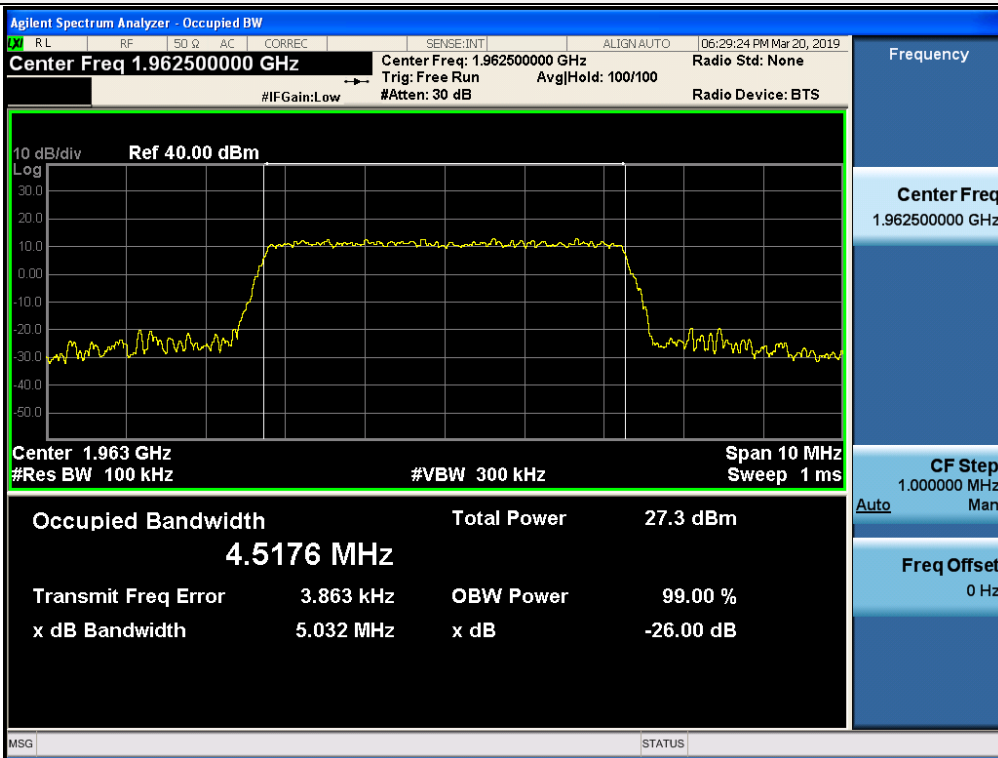

3 dB above the AGC threshold output / Broadband PCS / Downlink / LTE 10 MHz

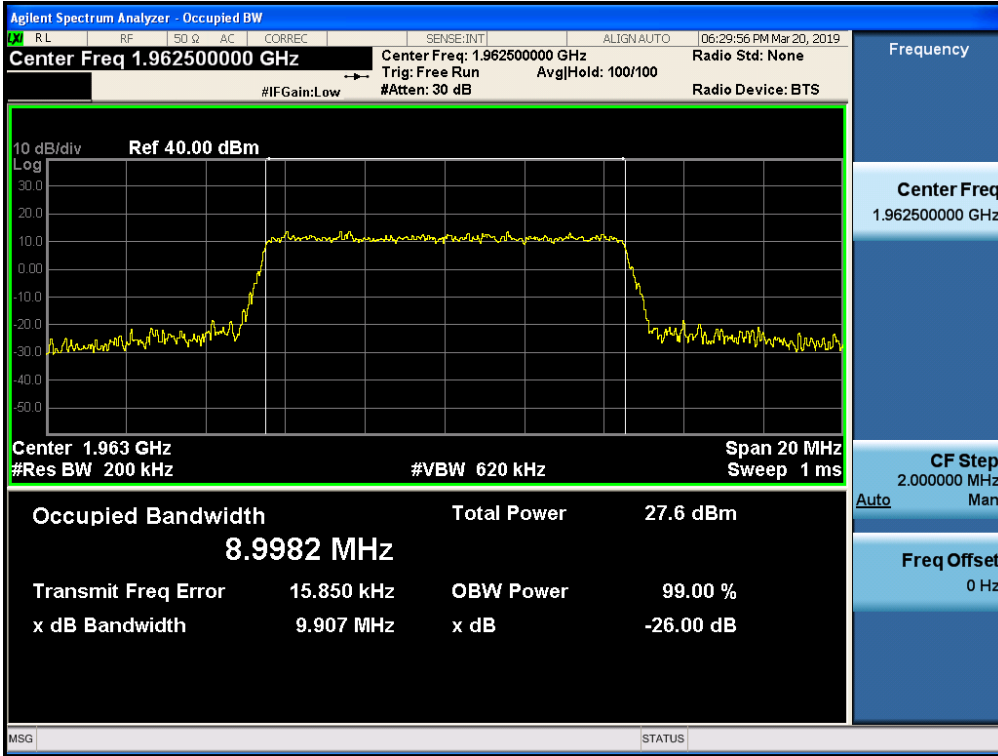

3 dB above the AGC threshold output / Broadband PCS / Downlink / LTE 20 MHz

