

TEST REPORT

FCC Test for eROUa_682335_X
Certification

APPLICANT
SOLiD, Inc.

REPORT NO.
HCT-RF-2006-FC028-R1

DATE OF ISSUE
October 13, 2020

Tested by
Kyung Soo Kang



Technical Manager
Kwon Jeong



HCT CO., LTD.

Soo Chan Lee
SooChan Lee / CEO

HCT CO., LTD.

74, Seoicheon-ro 578beon-gil, Majang-myeon, Icheon-si, Gyeonggi-do, 17383 KOREA
Tel. +82 31 634 6300 F ax. +82 31 645 6401

HCT Co., Ltd.

74, Seoicheon-ro 578beon-gil, Majang-myeon, Icheon-si, Gyeonggi-do, 17383 KOREA
Tel. +82 31 634 6300 Fax. +82 31 645 6401

TEST REPORT

FCC Test for
eROUa_682335_X

REPORT NO.
HCT-RF-2006-FC028-R1

DATE OF ISSUE
October 13, 2020

Additional Model
-

Applicant SOLiD, Inc.
10, 9th Floor, SOLiD Space, Pangyojeok-ro 220, Bundang-gu, Seongnam-si,

Eut Type DAS
Model Name eROUa_682335_X

FCC ID W6UEROUA682335

Output Power 19 dBm(600 MHz, ESMR, Cellular), 23 dBm(WCS)

Date of Test May 25, 2020 ~ August 12, 2020

FCC Rule Part 2, Part 22, Part 27, Part 90

The result shown in this test report refer only to the sample(s) tested unless otherwise stated.
This test results were applied only to the test methods required by the standard.

REVISION HISTORY

The revision history for this test report is shown in table.

Revision No.	Date of Issue	Description
0	August 13, 2020	Initial Release
1	October 13, 2020	Removed the CBRS band data.

The measurements shown in this report were made in accordance with the procedures indicated, and the emissions from this equipment were found to be within the limits applicable. I assume full responsibility for the accuracy and completeness of these measurements, and for the qualifications of all persons taking them. It is further stated that upon the basis of the measurements made, the equipment tested is capable of operation in accordance with the requirements of the FCC Rules under normal use and maintenance.

* The report shall not be reproduced except in full(only partly) without approval of the laboratory.

CONTENTS

1. GENERAL INFORMATION	5
1.1. APPLICANT INFORMATION	5
1.2. PRODUCT INFORMATION	5
1.3. TEST INFORMATION	5
2. FACILITIES AND ACCREDITATIONS	6
2.1. FACILITIES	6
2.2. EQUIPMENT	6
3. TEST SPECIFICATIONS	7
3.1. STANDARDS	7
3.2. ADDITIONAL DESCRIPTIONS ABOUT TEST	8
3.3. MEASUREMENT UNCERTAINTY	11
3.4. STANDARDS ENVIRONMENTAL TEST CONDITIONS	11
3.5. TEST DIAGRAMS	12
4. TEST EQUIPMENTS	13
5. TEST RESULT	14
5.1. AGC THRESHOLD	14
5.2. OUT-OF-BAND REJECTION	17
5.3. INPUT-VERSUS-OUTPUT SIGNAL COMPARISON	20
5.4. INPUT/OUTPUT POWER AND AMPLIFIER/BOOSTER GAIN	51
5.5. OUT-OF-BAND/OUT-OF-BLOCK EMISSIONS AND SPURIOUS EMISSIONS	65
5.6. RADIATED SPURIOUS EMISSIONS	144
6. Annex A_EUT AND TEST SETUP PHOTO	152

1. GENERAL INFORMATION

1.1. APPLICANT INFORMATION

Company Name	SOLiD, Inc.
Company Address	10, 9th Floor, SOLiD Space, Pangyoyeok-ro 220, Bundang-gu, Seongnam-si, Gyeonggi-do, 463-400, South Korea

1.2. PRODUCT INFORMATION

EUT Type	DAS															
EUT Serial Number	EX20400001															
Power Supply	DC 39~57 Vdc															
Frequency Range	<table border="1" style="width: 100%; border-collapse: collapse;"> <thead> <tr> <th style="width: 30%;">Band Name</th> <th style="width: 35%;">Uplink (MHz)</th> <th style="width: 35%;">Downlink (MHz)</th> </tr> </thead> <tbody> <tr> <td style="text-align: center;">600 MHz</td> <td style="text-align: center;">663 ~ 698</td> <td style="text-align: center;">617 ~ 652</td> </tr> <tr> <td style="text-align: center;">ESMR</td> <td style="text-align: center;">817 ~ 824</td> <td style="text-align: center;">862 ~ 894</td> </tr> <tr> <td style="text-align: center;">Cellular</td> <td style="text-align: center;">824 ~ 849</td> <td style="text-align: center;">869 ~ 894</td> </tr> <tr> <td style="text-align: center;">WCS</td> <td style="text-align: center;">2 305 ~ 2 315</td> <td style="text-align: center;">2 350 ~ 2360</td> </tr> </tbody> </table>	Band Name	Uplink (MHz)	Downlink (MHz)	600 MHz	663 ~ 698	617 ~ 652	ESMR	817 ~ 824	862 ~ 894	Cellular	824 ~ 849	869 ~ 894	WCS	2 305 ~ 2 315	2 350 ~ 2360
	Band Name	Uplink (MHz)	Downlink (MHz)													
	600 MHz	663 ~ 698	617 ~ 652													
	ESMR	817 ~ 824	862 ~ 894													
	Cellular	824 ~ 849	869 ~ 894													
WCS	2 305 ~ 2 315	2 350 ~ 2360														
Tx Output Power	19 dBm(600 MHz, ESMR, Cellular), 23 dBm(WCS)															
Antenna Peak Gain	17 dBi															

1.3. TEST INFORMATION

FCC Rule Parts	Part 2, Part 22, Part 27, Part 90
Measurement Standards	KDB 935210 D05 v01r04, ANSI C63.26-2015
Test Location	HCT CO., LTD. 74, Seoicheon-ro 578beon-gil, Majang-myeon, Icheon-si, Gyeonggi-do, 17383, Rep. of KOREA

2. FACILITIES AND ACCREDITATIONS

2.1. FACILITIES

The SAC(Semi-Anechoic Chamber) and conducted measurement facility used to collect the radiated data are located at the 74, Seoicheon-ro 578beon-gil, Majang-myeon, Icheon-si, Gyeonggi-do, 17383, Rep. of KOREA.

The site is constructed in conformance with the requirements of ANSI C63.4 (Version: 2014) and CISPR Publication 22.

Detailed description of test facility was submitted to the Commission and accepted dated April 02, 2018 (Registration Number: KR0032).

2.2. EQUIPMENT

Radiated emissions are measured with one or more of the following types of linearly polarized antennas: tuned dipole, bi-conical, log periodic, bi-log, and/or ridged waveguide, horn. Spectrum analyzers with pre-selectors and quasi-peak detectors are used to perform radiated measurements.

Calibrated wideband preamplifiers, coaxial cables, and coaxial attenuators are also used for making measurements.

All receiving equipment conforms to CISPR Publication 16-1, "Radio Interference Measuring Apparatus and Measurement Methods."



3. TEST SPECIFICATIONS

3.1. STANDARDS

The following tests were conducted on a sample of the equipment for the purpose of demonstrating compliance with FCC Part 2, Part 22, Part 27, Part 90.

Description	Reference	Results
AGC threshold	KDB 935210 D05 v01r04 3.2	Compliant
Out-of-band rejection	KDB 935210 D05 v01r04 3.3	Compliant
Input-versus-output signal comparison	§ 2.1049	Compliant
Input/output power and amplifier/booster gain	§ 2.1046, § 22.913, § 27.50(a), (c), § 90.635	Compliant
Out-of-band/out-of-block emissions and spurious emissions	§ 2.1051, § 22.917, § 27.53(a), (g), § 90.691	Compliant
Spurious emissions radiated	§ 2.1053	Compliant

3.2. ADDITIONAL DESCRIPTIONS ABOUT TEST

Except for the following cases, EUT was tested under normal operating conditions.

: Out-of-band rejection test requires maximum gain condition without AGC.

This EUT is supported power supply both of AC and DC. Test results are only attached worst cases.

The test was generally based on the method of KDB 935210 D05 v01r04 and only followed ANSI C63.26-2015 if there was no test method in KDB standard.

EUT was tested with following modulated signals provide by applicant.

Band Name	Tested signals
600 MHz	LTE 5 MHz
	LTE 10 MHz
	LTE 20 MHz
ESMR	CDMA
	LTE 5 MHz
	WCDMA
Cellular	CDMA
	WCDMA
	LTE 5 MHz
	LTE 10 MHz
WCS	LTE 5 MHz
	LTE 10 MHz

*Note: We have done CDMA and 1xEVDO modulation test in technology. Test results are only attached worst cases.

Simultaneous band condition

Ant 1	
ESMR, Cellular	WCS



The frequency stability measurement has been omitted in accordance with section 3.7 of KDB 935210 D05 v01r04.
 : It can be confirmed through input-versus-output signal comparison test that EUT does not alter the input signal.

The tests results included actual loss value for attenuator and cable combination as shown in the table below.

: Input Path

Correction factor table			
Frequency (MHz)	Factor (dB)	Frequency (MHz)	Factor (dB)
600	0.692	2 400	1.237
700	0.782	2 500	1.410
800	0.725	2 600	1.376
900	0.717	2 700	1.062
1 000	0.643	2 800	1.114
1 100	0.697	2 900	1.365
1 200	0.878	3 000	1.496
1 300	0.974	3 100	1.231
1 400	0.917	3 200	1.121
1 500	1.061	3 300	1.251
1 600	1.044	3400	1.323
1 700	0.911	3500	1.456
1 800	0.794	3600	1.610
1 900	0.966	3700	1.845
2 000	0.985	3800	2.277
2 100	1.078	3900	1.675
2 200	1.131	4000	1.844
2 300	1.428		

: Output Path

Correction factor table			
Frequency (MHz)	Factor (dB)	Frequency (MHz)	Factor (dB)
10	29.486	3 000	31.227
30	29.533	4 000	31.525
50	29.432	5 000	31.619
100	29.508	6 000	31.804
200	29.625	7 000	32.023
300	29.936	8 000	32.374
400	30.073	9 000	32.647
500	30.137	10 000	34.562
600	30.205	11 000	33.648
700	30.282	12 000	33.602
800	30.284	13 000	33.219
900	30.236	14 000	34.451
1 000	30.269	15 000	34.300
1 100	30.289	16 000	34.581
1 200	30.477	17 000	34.189
1 300	30.537	18 000	34.800
1 400	30.546	19 000	35.367
1 500	30.595	20 000	38.400
1 600	30.693	21 000	39.200
1 700	30.547	22 000	40.555
1 800	30.532	23 000	38.729
1 900	30.561	24 000	40.305
2 000	30.713	25 000	39.305
2 100	30.750	26 000	43.706
2 200	30.777	26 500	38.644
2 300	30.787	-	-
2 400	30.873	-	-
2 500	30.847	-	-
2 600	30.941	-	-
2 700	30.798	-	-

3.3. MEASUREMENT UNCERTAINTY

Description	Reference	Results
AGC threshold	-	± 0.87 dB
Out-of-band rejection	-	± 0.58 MHz
Input-versus-output signal comparison	OBW > 5 MHz	± 0.58 MHz
Input/output power and amplifier/booster gain	-	± 0.87 dB
Out-of-band/out-of-block emissions and spurious emissions	-	± 1.08 dB
Spurious emissions radiated	$f \leq 1$ GHz	± 4.80 dB
	$f > 1$ GHz	± 6.07 dB

* Coverage factor $k = 2$, Confidence levels of 95 %

3.4. STANDARDS ENVIRONMENTAL TEST CONDITIONS

Temperature	+15 °C to +35 °C
Relative humidity	30 % to 60 %
Air pressure	860 mbar to 1 060 mbar

3.5. TEST DIAGRAMS

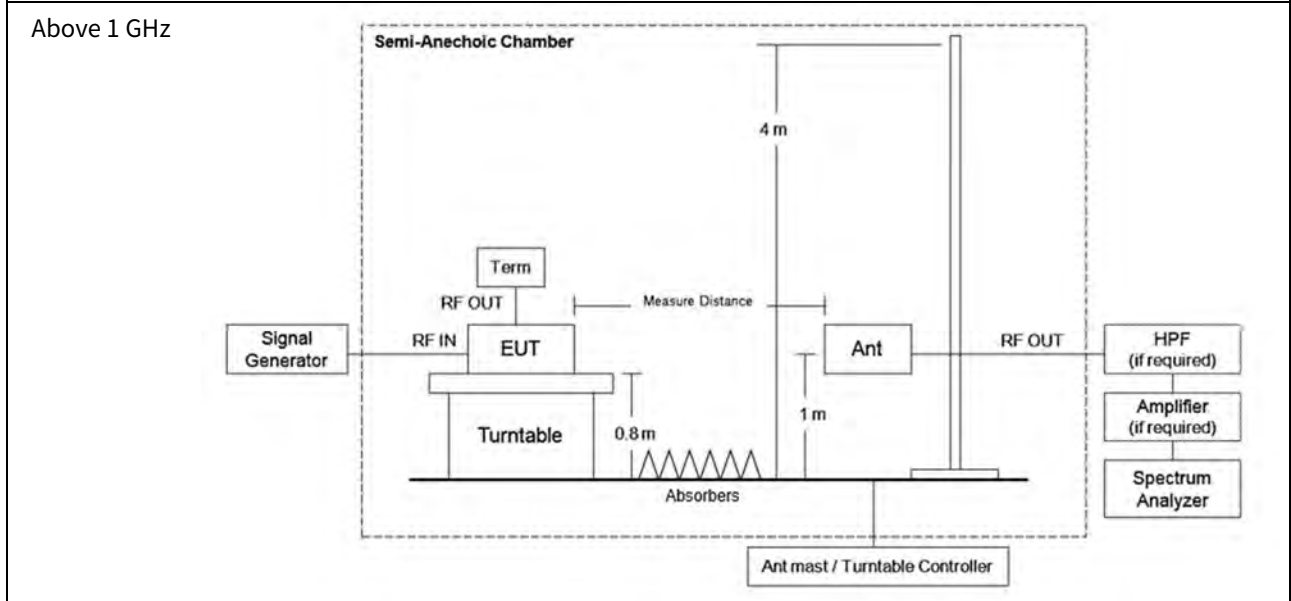
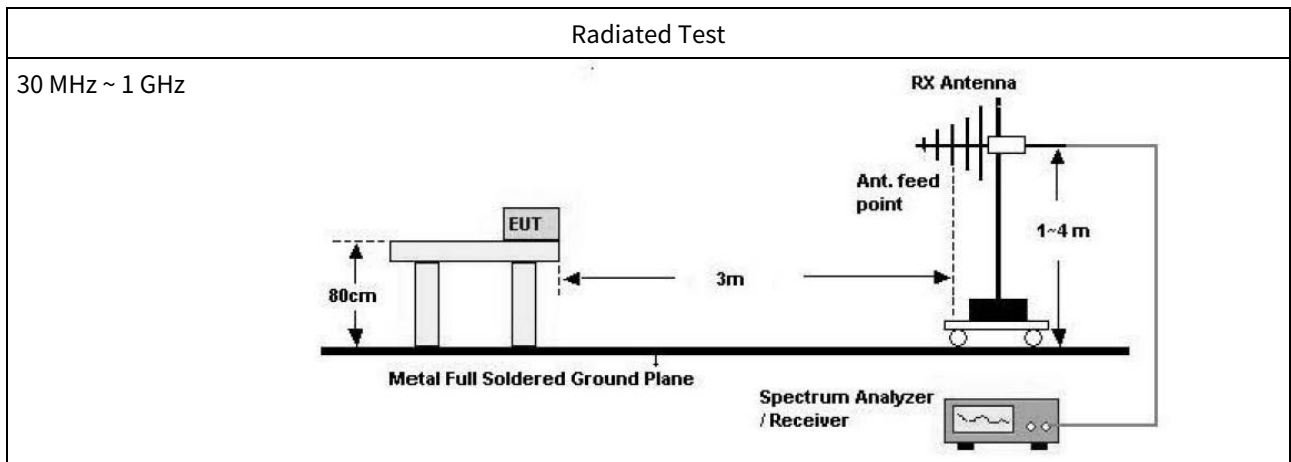
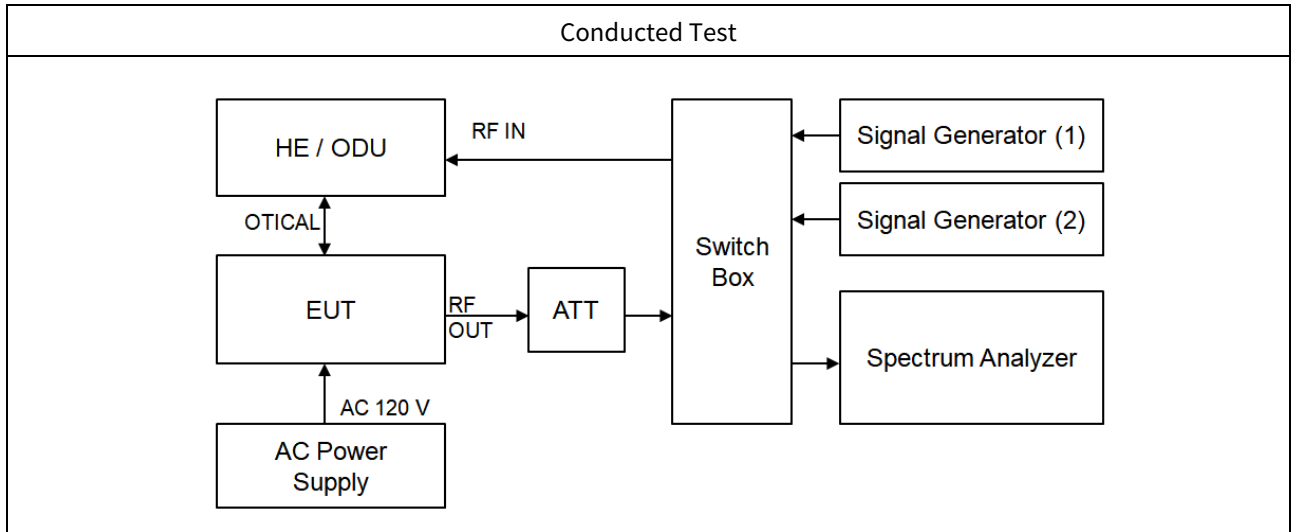

※ EUT position is adopted by placement of floor-standing refer to section 5.5.2.3.2 of ANSI C63.26-2015

4. TEST EQUIPMENTS

Manufacturer	Model / Equipment	Calibration Date	Calibration Interval	Serial No.
Agilent	N9020A / MXA Signal Analyzer	08/21/2019	Annual	MY46471250
Agilent	N9030B / PXA Signal Analyzer	06/04/2020	Annual	MY55480167
Agilent	N5182A / MXG Vector Signal Generator	08/21/2019	Annual	MY50140312
Agilent	N5182A / MXG Vector Signal Generator	01/17/2020	Annual	MY47070406
Weinschel Associates	WA93-30-33 / 30 dB Attenuator	04/09/2020	Annual	0202
Weinschel Associates	WA67-30-33 / 30 dB Attenuator	02/06/2021	Annual	CL4337
KEITHLEY	S46 / Switch	N/A	N/A	1088024
Deayoung ENT	DFSS60 / AC Power Supply	04/07/2020	Annual	1003030-1
Innco system	CO3000 / Controller(Antenna mast)	N/A	N/A	CO3000-4p
Innco system	MA4640/800-XP-EP / Antenna Position Tower	N/A	N/A	N/A
Audix	EM1000 / Controller	N/A	N/A	060520
Audix	Turn Table	N/A	N/A	N/A
TNM system	FBSM-01B / Amp & Filter Bank Switch Controller	N/A	N/A	N/A
Rohde & Schwarz	Loop Antenna	05/18/2020	Biennial	1513-175
Schwarzbeck	VULB 9168 / Hybrid Antenna	08/02/2019	Biennial	01039
Schwarzbeck	BBHA 9120D / Horn Antenna	06/28/2019	Biennial	1300
Schwarzbeck	BBHA9170 / Horn Antenna(15 GHz ~ 40 GHz)	04/29/2019	Biennial	BBHA9170342
Rohde & Schwarz	FSP(9 kHz ~ 40 GHz) / Spectrum Analyzer	06/08/2020	Annual	100843
TNM system	FBSM-05B / HPF(3~18GHz) + LNA1(1~18GHz)	01/21/2020	Annual	F6
TNM system	FBSM-05B / LNA1(1~18GHz)	01/21/2020	Annual	25540
Wainwright Instruments	WHKX10-900-1000-15000-40SS/ High Pass Filter	07/13/2020	Annual	5
CERNEX	CBL18265035 / Power Amplifier	12/26/2019	Annual	22966
CERNEX	CBL26405040 / Power Amplifier	03/23/2020	Annual	25956

Note:

1. Equipment listed above that calibrated during the testing period was set for test after the calibration.
2. Equipment listed above that has a calibration due date during the testing period, the testing is completed before equipment expiration date.

5. TEST RESULT

5.1. AGC THRESHOLD

Test Requirement:

KDB 935210 D05 v01r04

Testing at and above the AGC threshold is required.

Test Procedures:

Measurements were in accordance with the test methods section 3.2 of KDB 935210 D05 v01r04.

In the case of fiber-optic distribution systems, the RF input port of the equipment under test (EUT) refers to the RF input of the supporting equipment RF to optical convertor; see also descriptions and diagrams for typical DAS booster systems in KDB Publication 935210 D02.

Devices intended to be directly connected to an RF source (donor port) only need to be evaluated for any over-the-air transmit paths.

- a) Connect a signal generator to the input of the EUT.
- b) Connect a spectrum analyzer or power meter to the output of the EUT using appropriate attenuation as necessary.
- c) The signal generator should initially be configured to produce either of the required test signals (i.e., broadband or narrowband).
- d) Set the signal generator frequency to the center frequency of the EUT operating band.
- e) While monitoring the output power of the EUT, measured using the methods of 3.5.3 or 3.5.4, increase the input level until a 1 dB increase in the input signal power no longer causes a 1 dB increase in the output signal power.
- f) Record this level as the AGC threshold level.
- g) Repeat the procedure with the remaining test signal.

Output power measurement in subclause 5.2.4.4.1 of ANSI C63.26

- a) Set span to $2 \times$ to $3 \times$ the OBW.
- b) Set RBW = 1% to 5% of the OBW.
- c) Set VBW $\geq 3 \times$ RBW.
- d) Set number of measurement points in sweep $\geq 2 \times$ span / RBW.
- e) Sweep time: auto-couple
- f) Detector = power averaging (rms).
- g) If the EUT can be configured to transmit continuously, then set the trigger to free run.
- h) Omit

- i) Trace average at least 100 traces in power averaging (rms) mode if sweep is set to auto-couple. To accurately determine the average power over multiple symbols, it can be necessary to increase the number of traces to be averaged above 100 or, if using a manually configured sweep time, increase the sweep time.
- j) Compute the power by integrating the spectrum across the OBW of the signal using the instrument's band or channel power measurement function, with the band/channel limits set equal to the OBW band edges. If the instrument does not have a band or channel power function, then sum the spectrum levels (in linear power units) at intervals equal to the RBW extending across the entire OBW of the spectrum.

Test Results:

Test Band	Link	Signal	Center Frequency (MHz)	AGC Threshold Level (dBm)	Output Level (dBm)
600 MHz	Downlink	LTE 5 MHz	634.50	-20	19.26
		LTE 10 MHz	634.50	-20	19.37
		LTE 20 MHz	634.50	-20	19.29
ESMR		CDMA	865.50	-20	19.01
		WCDMA	865.50	-20	19.38
		LTE 5 MHz	865.50	-20	19.22
Cellular		CDMA	881.50	-20	19.16
		WCDMA	881.50	-20	19.06
		LTE 5 MHz	881.50	-20	19.12
		LTE 10 MHz	881.50	-20	19.10
WCS		LTE 5 MHz	2 355.00	-20	22.69
		LTE 10 MHz	2 355.00	-20	23.26

5.2. OUT-OF-BAND REJECTION

Test Requirement:

KDB 935210 D05 v01r04

Out-of-band rejection required.

Test Procedures:

Measurements were in accordance with the test methods section 3.3 of KDB 935210 D05 v01r04.

Adjust the internal gain control of the EUT to the maximum gain for which equipment certification is sought.

- a) Connect a signal generator to the input of the EUT.
- b) Configure a swept CW signal with the following parameters:
 - 1) Frequency range = ± 250 % of the passband, for each applicable CMRS band.
 - 2) Level = a sufficient level to affirm that the out-of-band rejection is > 20 dB above the noise floor and will not engage the AGC during the entire sweep.
 - 3) Dwell time = approximately 10 ms.
 - 4) Number of points = $\text{SPAN}/(\text{RBW}/2)$.
- c) Connect a spectrum analyzer to the output of the EUT using appropriate attenuation.
- d) Set the span of the spectrum analyzer to the same as the frequency range of the signal generator.
- e) Set the resolution bandwidth (RBW) of the spectrum analyzer to be 1 % to 5 % of the EUT passband, and the video bandwidth (VBW) shall be set to $\geq 3 \times \text{RBW}$.
- f) Set the detector to Peak Max-Hold and wait for the spectrum analyzer's spectral display to fill.
- g) Place a marker to the peak of the frequency response and record this frequency as f_0 .
- h) Place two markers, one at the lowest and the other at the highest frequency of the envelope of the spectral display, such that each marker is at or slightly below the -20 dB down amplitude, to determine the 20 dB bandwidth.
- i) Capture the frequency response of the EUT.
- j) Repeat for all frequency bands applicable for use by the EUT.

Test Results:

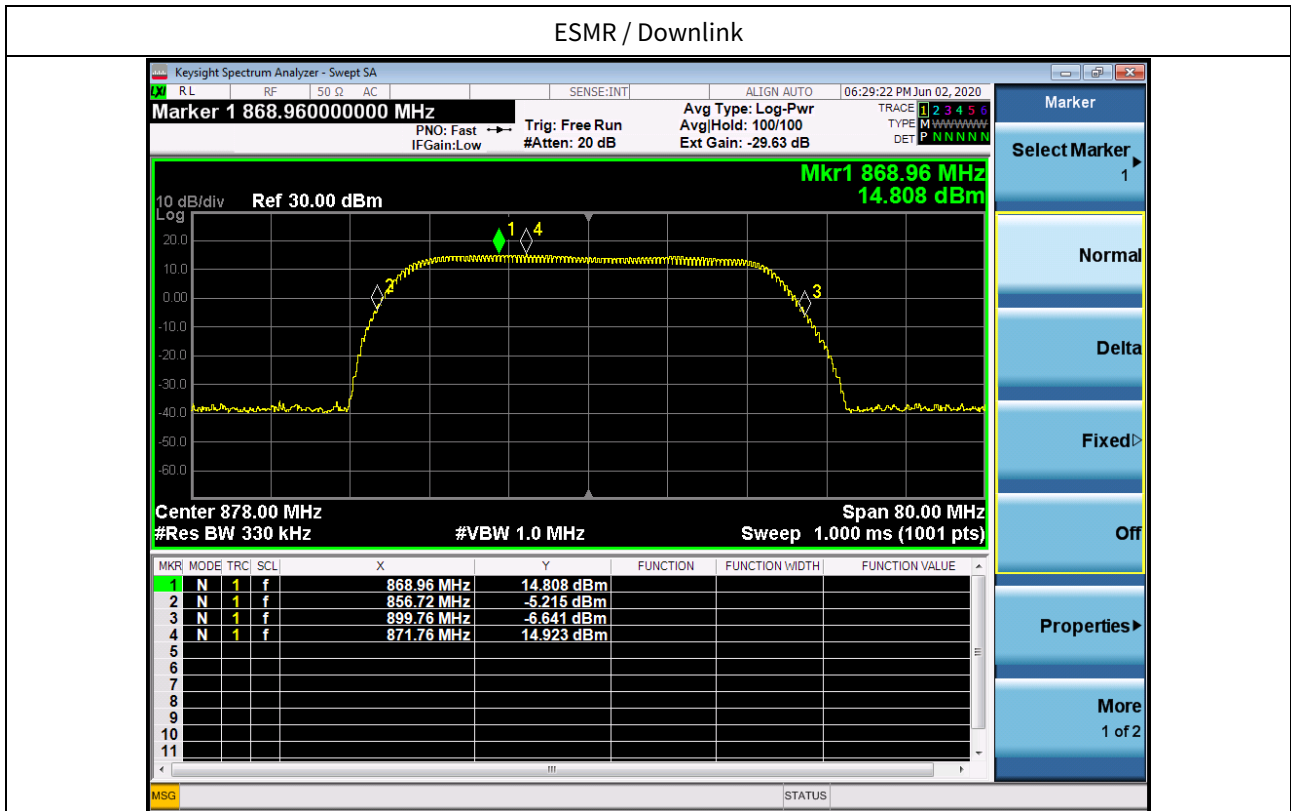
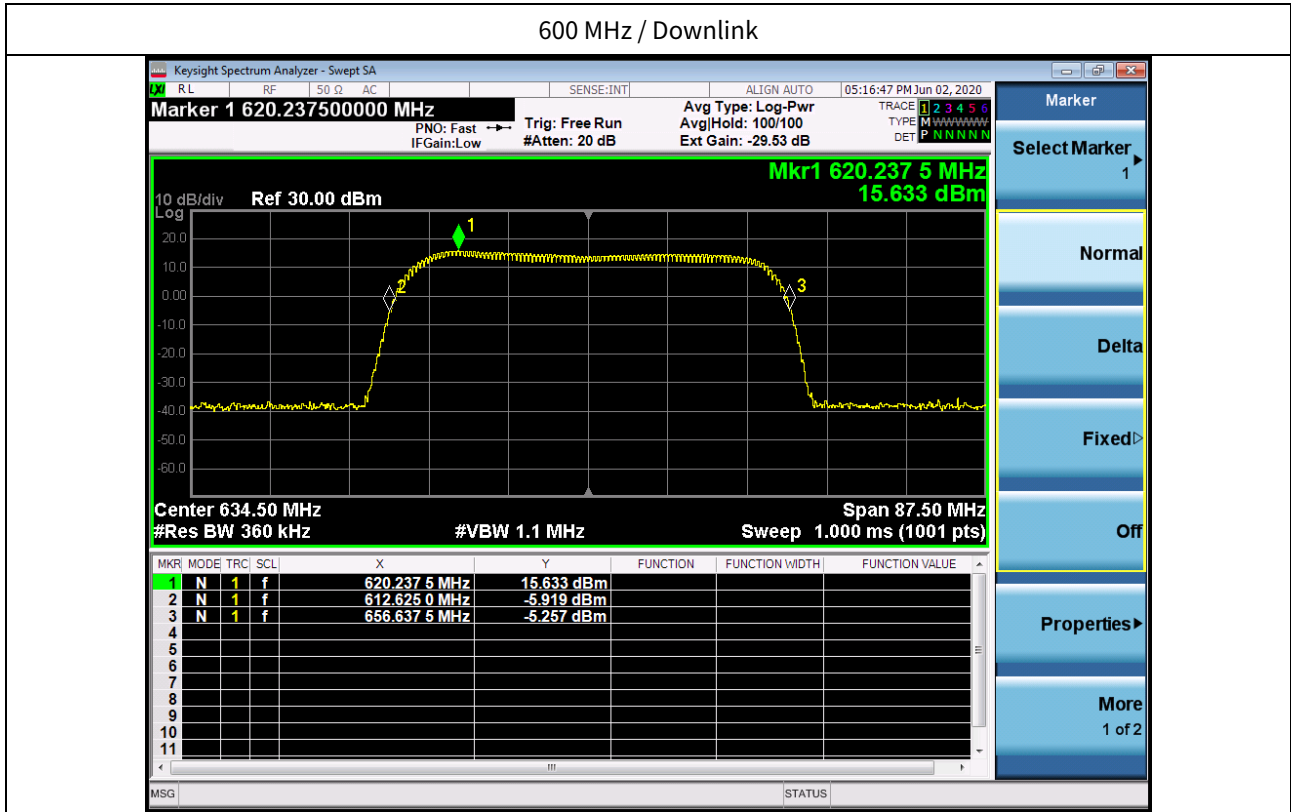

Cellular / Downlink

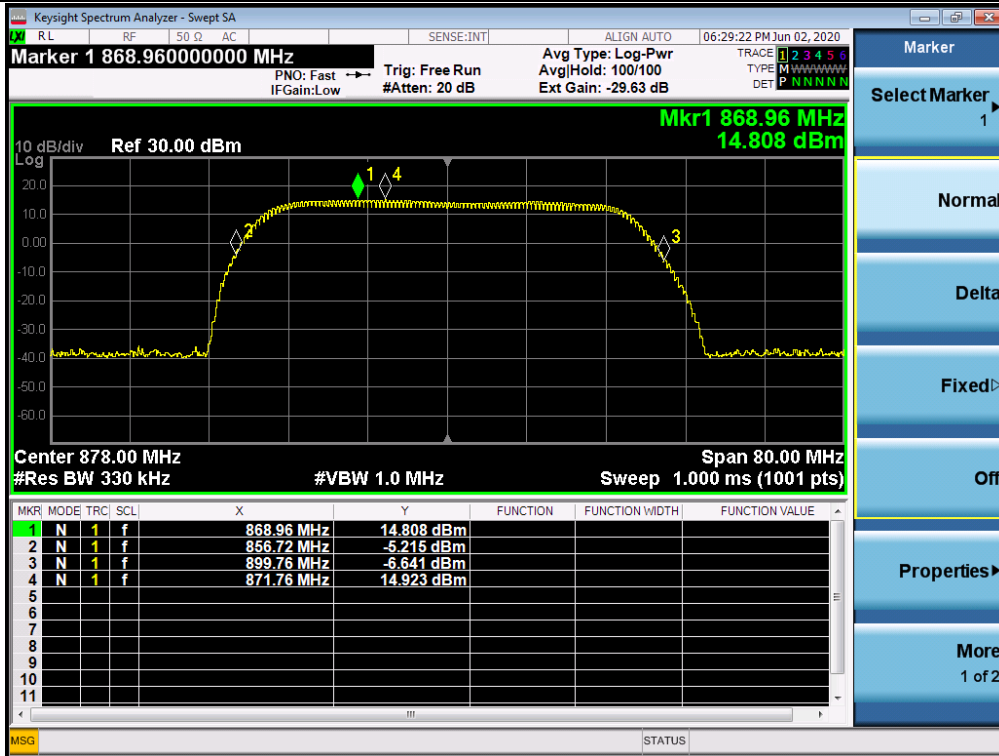

WCS / Downlink

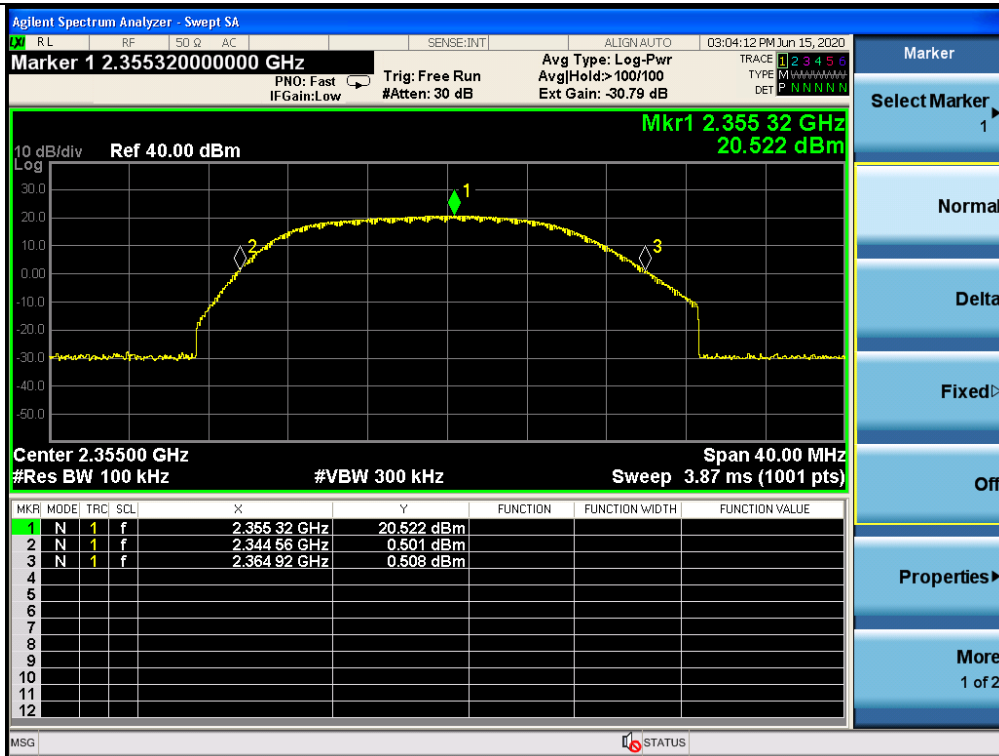

5.3. INPUT-VERSUS-OUTPUT SIGNAL COMPARISON

Test Requirement:

§ 2.1049 Measurements required: Occupied bandwidth.

The occupied bandwidth, that is the frequency bandwidth such that, below its lower and above its upper frequency limits, the mean powers radiated are each equal to 0.5 percent of the total mean power radiated by a given emission shall be measured under the specified conditions of § 2.1049 (a) through (i) as applicable.

Test Procedures:

Measurements were in accordance with the test methods section 3.4 of KDB 935210 D05 v01r04.

A 26 dB bandwidth measurement shall be performed on the input signal and the output signal; alternatively, the 99% OBW can be measured and used. See KDB Publication 971168 [R8] for more information on measuring OBW.

- a) Connect a signal generator to the input of the EUT.
- b) Configure the signal generator to transmit the AWGN signal.
- c) Configure the signal amplitude to be just below the AGC threshold level (see 3.2), but not more than 0.5 dB below.
- d) Connect a spectrum analyzer to the output of the EUT using appropriate attenuation.
- e) Set the spectrum analyzer center frequency to the center frequency of the operational band under test. The span range of the spectrum analyzer shall be between 2 times to 5 times the emission bandwidth (EBW) or alternatively, the OBW.
- f) The nominal RBW shall be in the range of 1 % to 5 % of the anticipated OBW, and the VBW shall be $\geq 3 \times$ RBW.
- g) Set the reference level of the instrument as required to preclude the signal from exceeding the maximum spectrum analyzer input mixer level for linear operation. In general, the peak of the spectral envelope must be more than $[10 \log (OBW / RBW)]$ below the reference level. Steps f) and g) may require iteration to enable adjustments within the specified tolerances.
- h) The noise floor of the spectrum analyzer at the selected RBW shall be at least 36 dB below the reference level.
- i) Set spectrum analyzer detection function to positive peak.
- j) Set the trace mode to max hold.
- k) Determine the reference value: Allow the trace to stabilize. Set the spectrum analyzer marker to the highest amplitude level of the displayed trace (this is the reference value) and record the associated frequency as f_0 .
- l) Place two markers, one at the lowest and the other at the highest frequency of the envelope of the spectral display, such that each marker is at or slightly below the -26 dB down amplitude. The 26 dB EBW (alternatively OBW) is the positive frequency difference between the two markers. If the spectral envelope crosses the -26 dB down amplitude at multiple points, the lowest or highest frequency shall be selected as the frequencies that are the furthest removed from the center frequency at which the spectral envelope crosses the -26 dB down amplitude point.

- m) Repeat steps e) to l) with the input signal connected directly to the spectrum analyzer (i.e., input signal measurement).
- n) Compare the spectral plot of the input signal (determined from step m) to the output signal (determined from step l) to affirm that they are similar (in passband and rolloff characteristic features and relative spectral locations), and include plot(s) and descriptions in test report.
- o) Repeat the procedure [steps e) to n)] with the input signal amplitude set to 3 dB above the AGC threshold.
- p) Repeat steps e) to o) with the signal generator set to the narrowband signal.
- q) Repeat steps e) to p) for all frequency bands authorized for use by the EUT.



Test Results:

Tabular data of Output Occupied Bandwidth

Test Band	Link	Signal	Center Frequency (MHz)	99 % OBW (MHz)
600 MHz	Downlink	LTE 5 MHz	634.50	4.5249
		LTE 10 MHz	634.50	9.0193
		LTE 20 MHz	634.50	18.042
ESMR		CDMA	865.50	1.2615
		WCDMA	865.50	4.1923
		LTE 5 MHz	865.50	4.5264
Cellular		CDMA	881.50	1.2597
		WCDMA	881.50	4.2007
		LTE 5 MHz	881.50	4.5192
		LTE 10 MHz	881.50	9.0407
		LTE 5 MHz	2 355.00	4.5183
WCS		LTE 10 MHz	2 355.00	8.9645

Tabular data of Input Occupied Bandwidth

Test Band	Link	Signal	Center Frequency (MHz)	99 % OBW (MHz)
600 MHz	Downlink	LTE 5 MHz	634.50	4.5275
		LTE 10 MHz	634.50	9.0105
		LTE 20 MHz	634.50	18.012
ESMR		CDMA	865.50	1.2635
		WCDMA	865.50	4.1778
		LTE 5 MHz	865.50	4.5248
Cellular		CDMA	881.50	1.2588
		WCDMA	881.50	4.1716
		LTE 5 MHz	881.50	4.5271
		LTE 10 MHz	881.50	9.0143
WCS		LTE 5 MHz	2 355.00	4.5159
		LTE 10 MHz	2 355.00	9.0050

Tabular data of 3 dB above the AGC threshold Output Occupied Bandwidth

Test Band	Link	Signal	Center Frequency (MHz)	99 % OBW (MHz)
600 MHz	Downlink	LTE 5 MHz	634.50	4.5218
		LTE 10 MHz	634.50	9.0419
		LTE 20 MHz	634.50	18.036
ESMR		CDMA	865.50	1.2618
		WCDMA	865.50	4.1901
		LTE 5 MHz	865.50	4.5234
Cellular		CDMA	881.50	1.2657
		WCDMA	881.50	4.1723
		LTE 5 MHz	881.50	4.5273
		LTE 10 MHz	881.50	9.0304
WCS		LTE 5 MHz	2 355.00	4.5177
		LTE 10 MHz	2 355.00	8.9641



Tabular data of 3 dB above the AGC threshold Input Occupied Bandwidth

Test Band	Link	Signal	Center Frequency (MHz)	99 % OBW (MHz)
600 MHz	Downlink	LTE 5 MHz	634.50	4.5203
		LTE 10 MHz	634.50	9.0184
		LTE 20 MHz	634.50	17.951
ESMR		CDMA	865.50	1.2618
		WCDMA	865.50	4.1808
		LTE 5 MHz	865.50	4.5198
Cellular		CDMA	881.50	1.2599
		WCDMA	881.50	4.2006
		LTE 5 MHz	881.50	4.5153
		LTE 10 MHz	881.50	9.0232
WCS		LTE 5 MHz	2 355.00	4.5201
		LTE 10 MHz	2 355.00	9.0224

Measured Occupied Bandwidth Comparison

Test Band	Link	Signal	Variant of Input and output Occupied Bandwidth (%)	Variant of Input and 3 dB above the AGC threshold output Occupied Bandwidth (%)
600 MHz	Downlink	LTE 5 MHz	-0.219	-0.237
		LTE 10 MHz	-0.110	-0.348
		LTE 20 MHz	0.353	0.535
ESMR		CDMA	-0.072	0.143
		WCDMA	0.276	-0.761
		LTE 5 MHz	0.160	0.000
Cellular		CDMA	0.287	-0.071
		WCDMA	0.466	-0.402
		LTE 5 MHz	-0.397	-0.099
		LTE 10 MHz	-0.636	1.043
WCS		LTE 5 MHz	0.220	0.100
		LTE 10 MHz	-0.260	-1.399

* Change in input-output OBW is less than $\pm 5\%$.

Plot data of Occupied Bandwidth

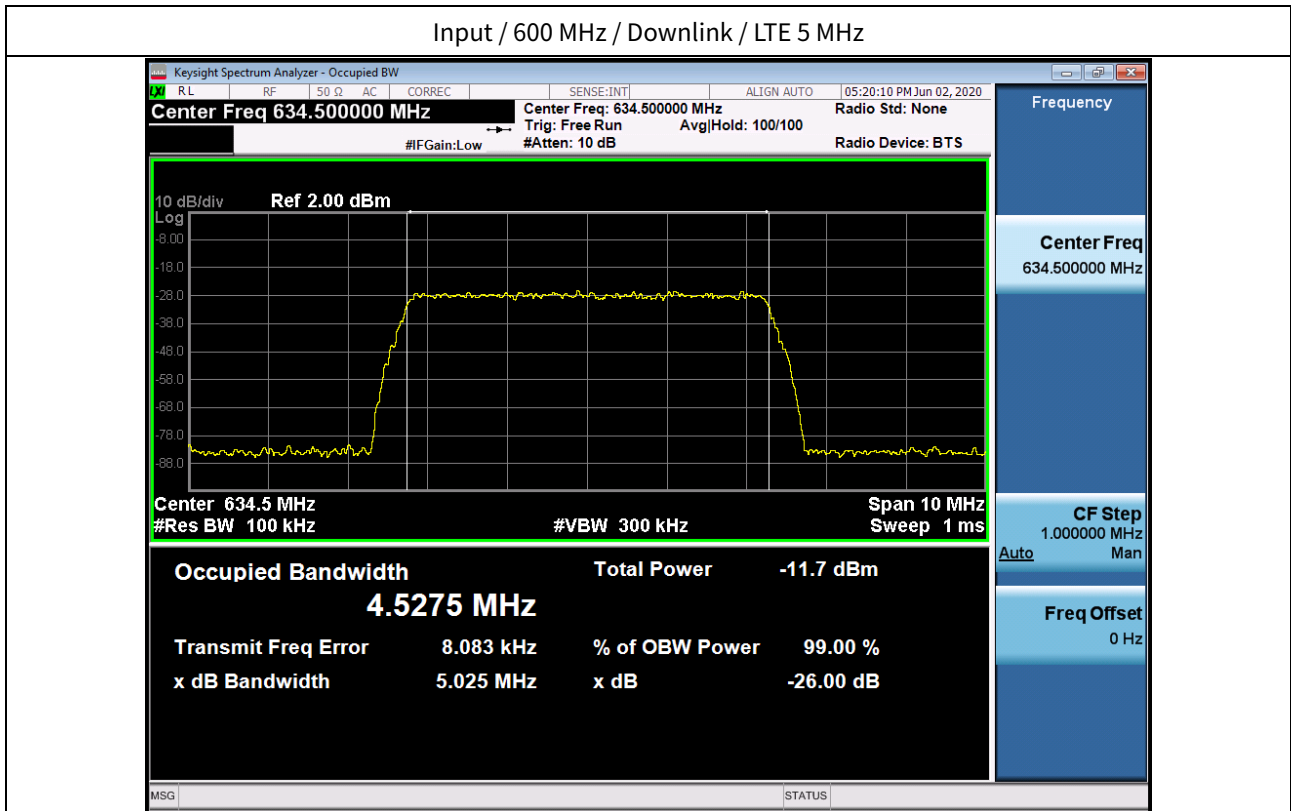
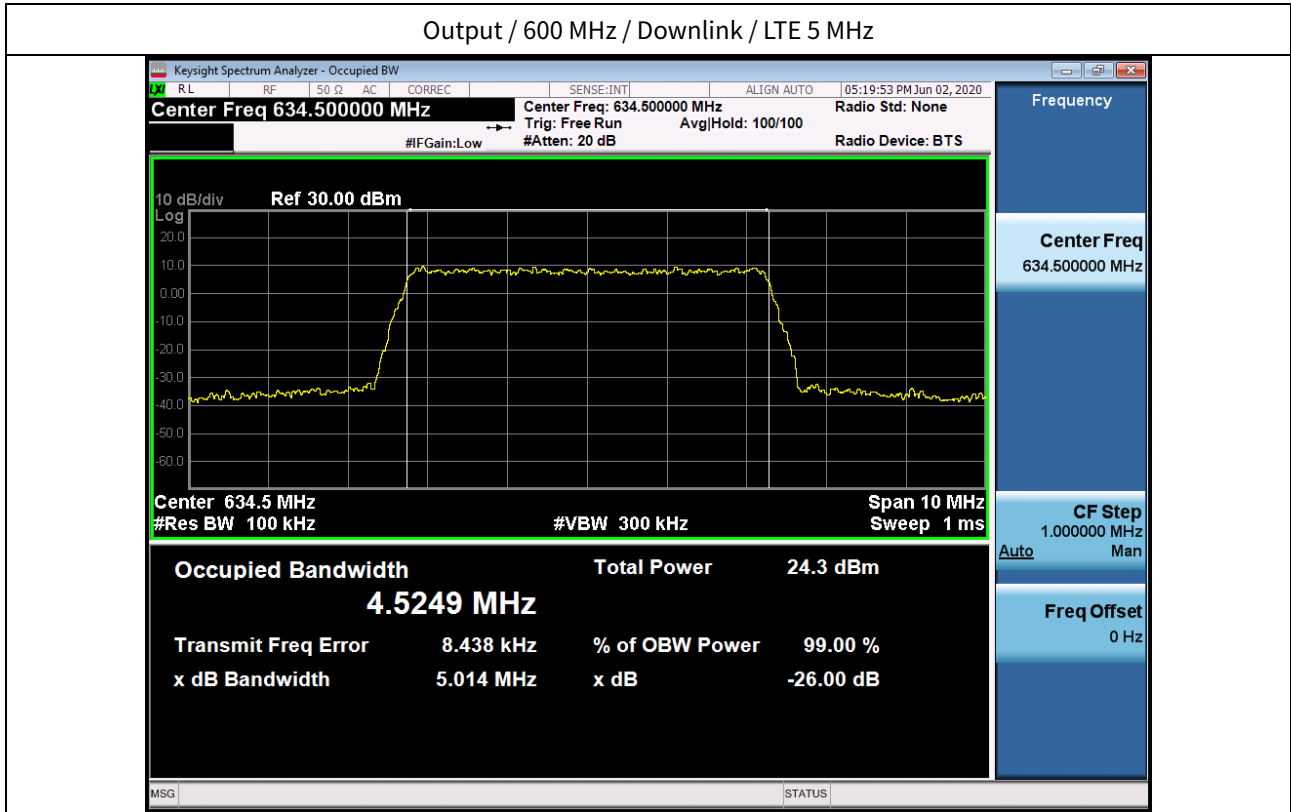

3 dB above the AGC threshold output / 600 MHz / Downlink / LTE 5 MHz

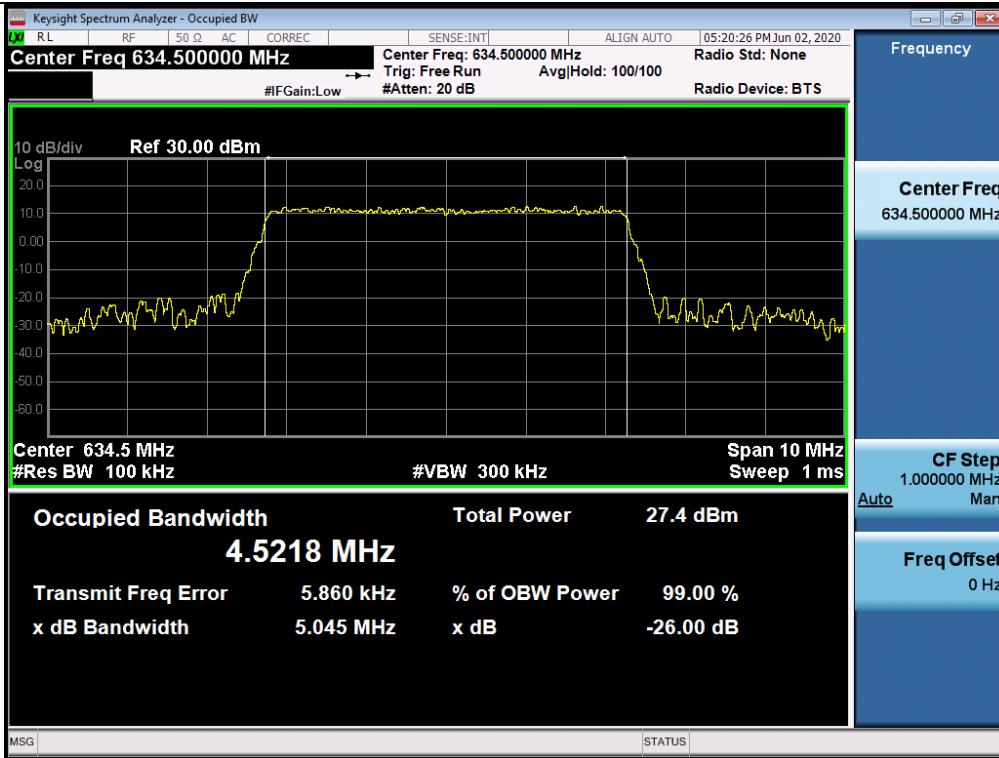

3 dB above the AGC threshold Input / 600 MHz / Downlink / LTE 5 MHz

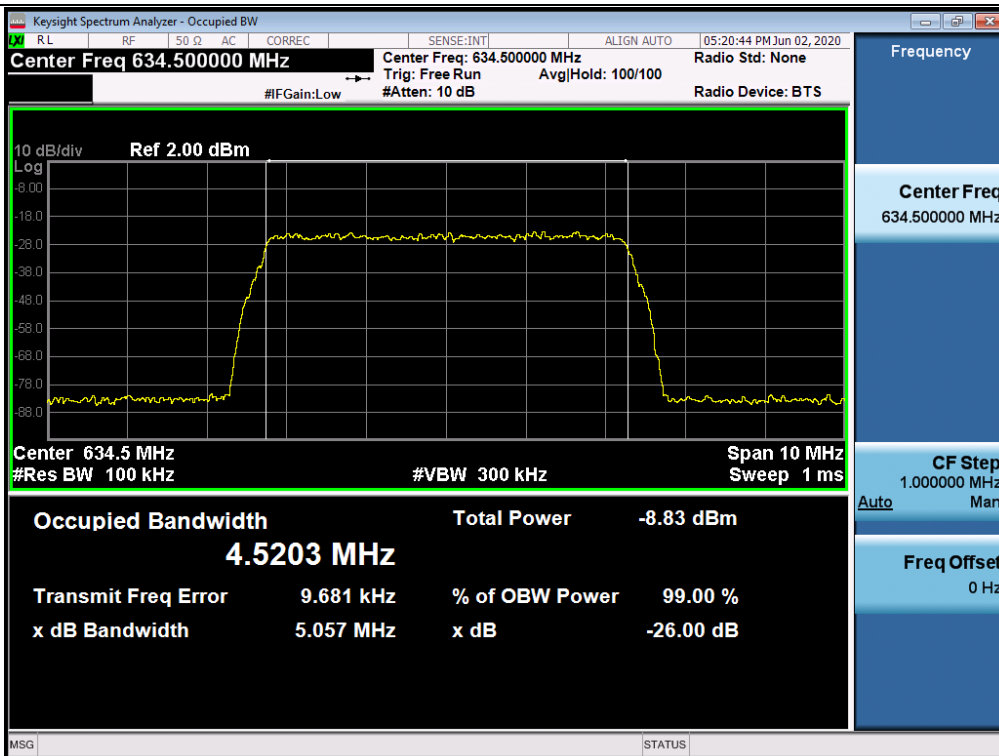

Output / 600 MHz / Downlink / LTE 10 MHz

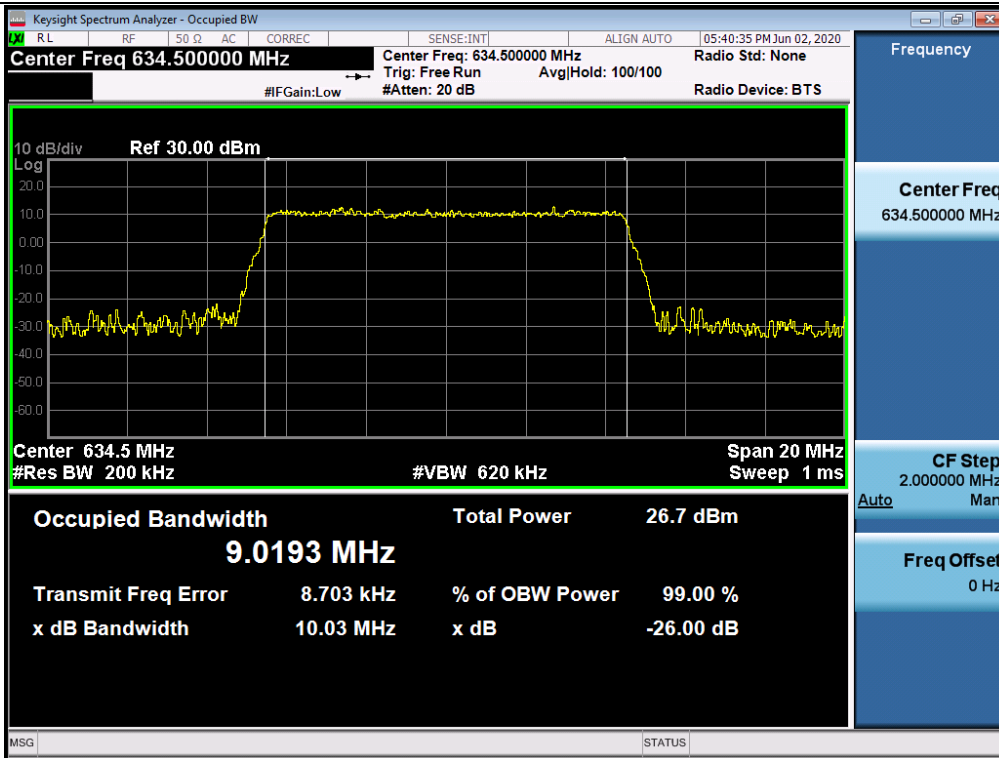

Input / 600 MHz / Downlink / LTE 10 MHz

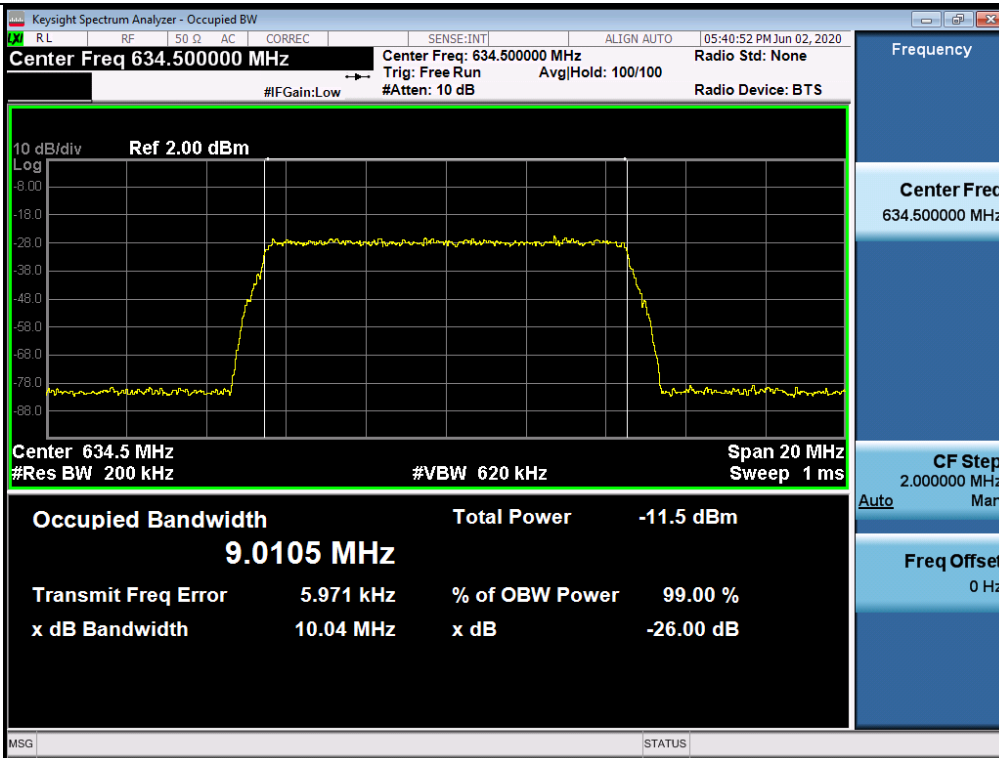

3 dB above the AGC threshold output / 600 MHz / Downlink / LTE 10 MHz

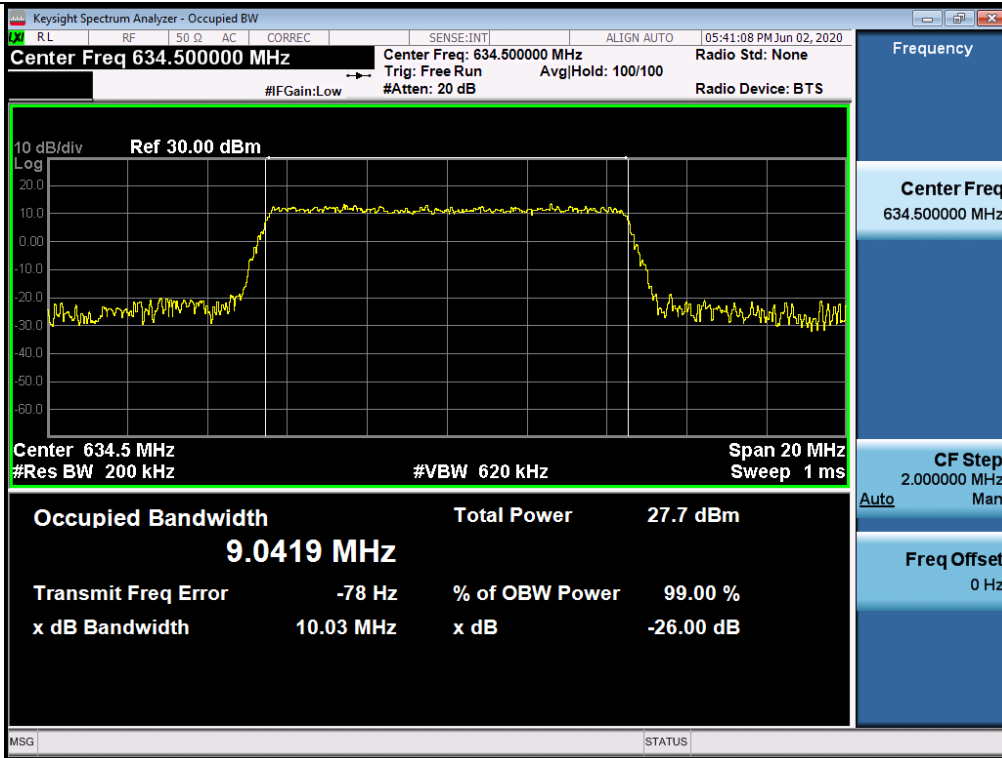

3 dB above the AGC threshold Input / 600 MHz / Downlink / LTE 10 MHz

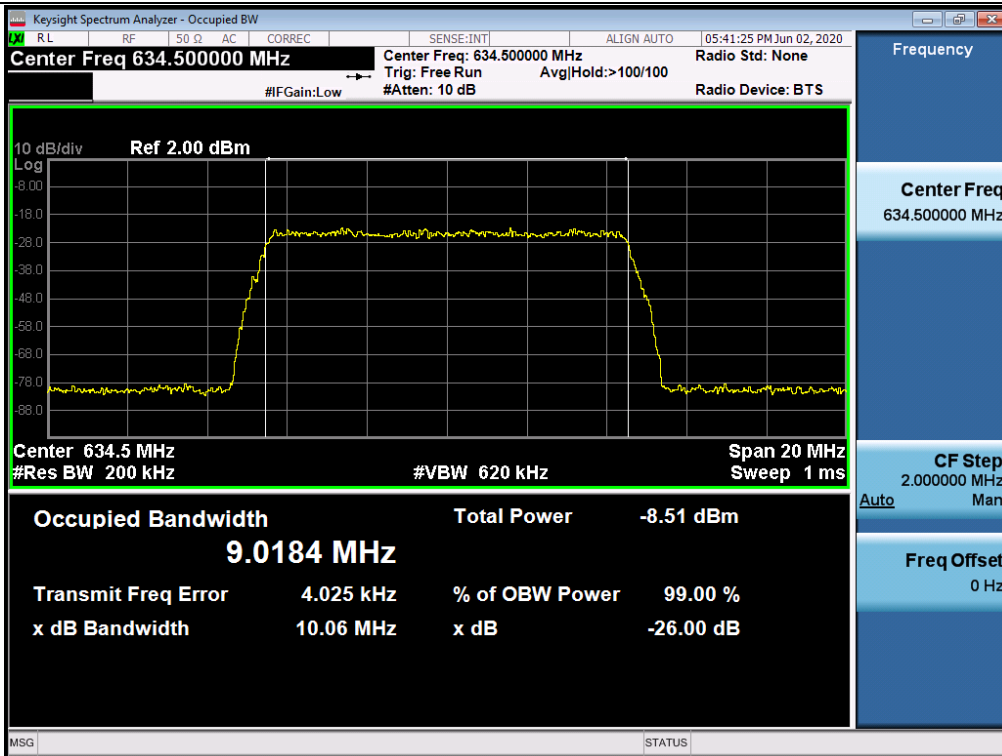

Output / 600 MHz / Downlink / LTE 20 MHz

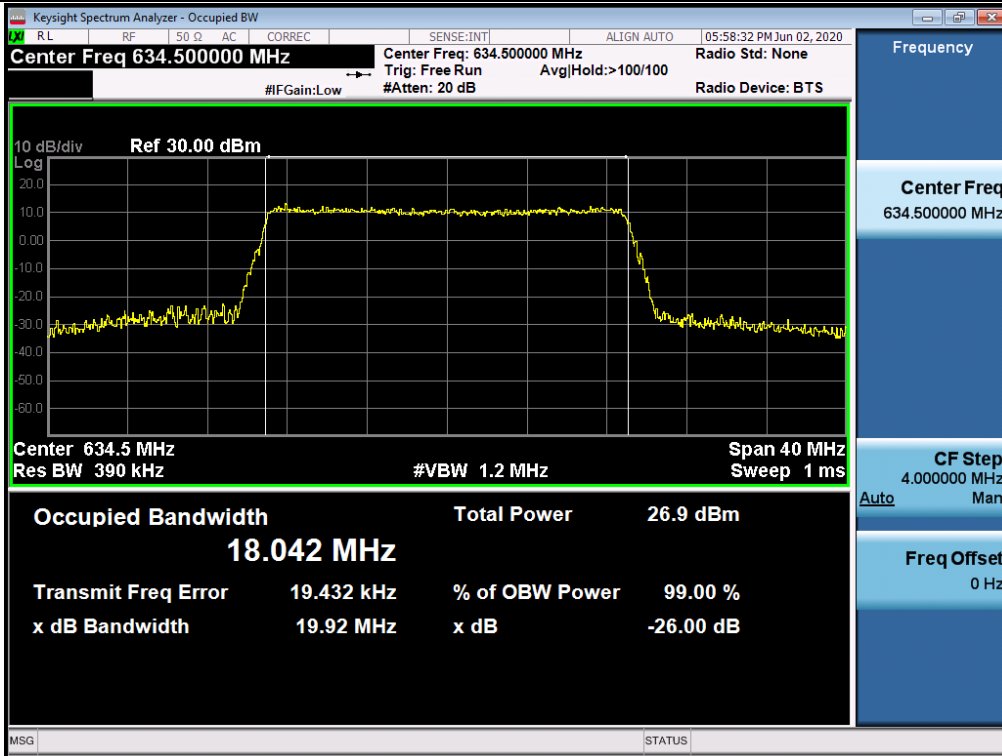

Input / 600 MHz / Downlink / LTE 20 MHz

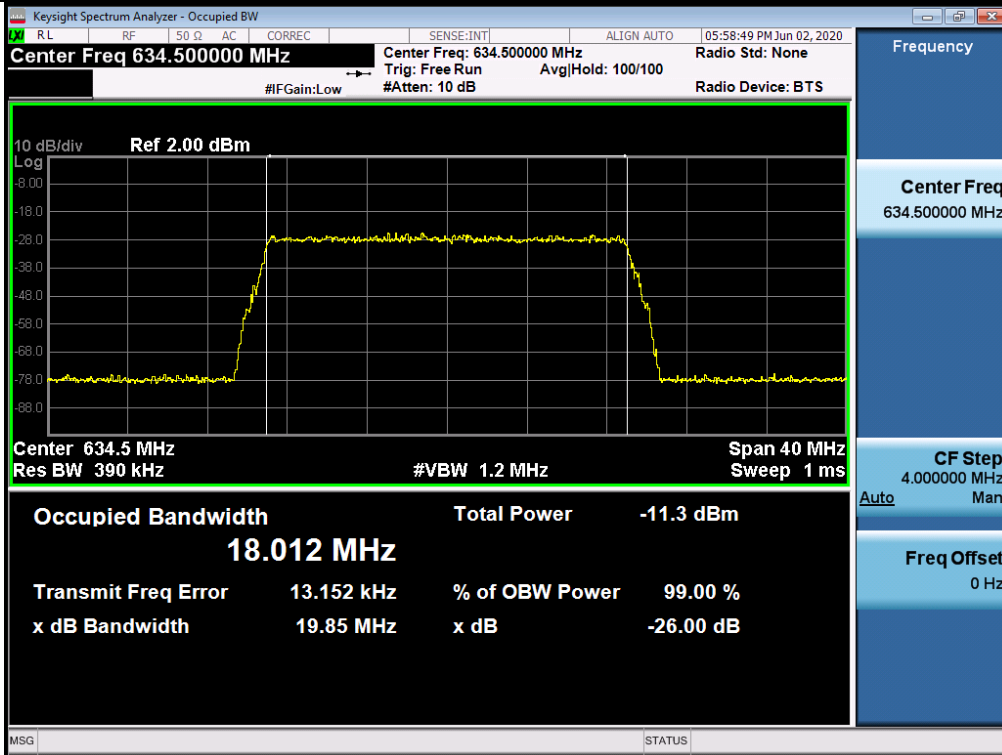

3 dB above the AGC threshold output / 600 MHz / Downlink / LTE 20 MHz

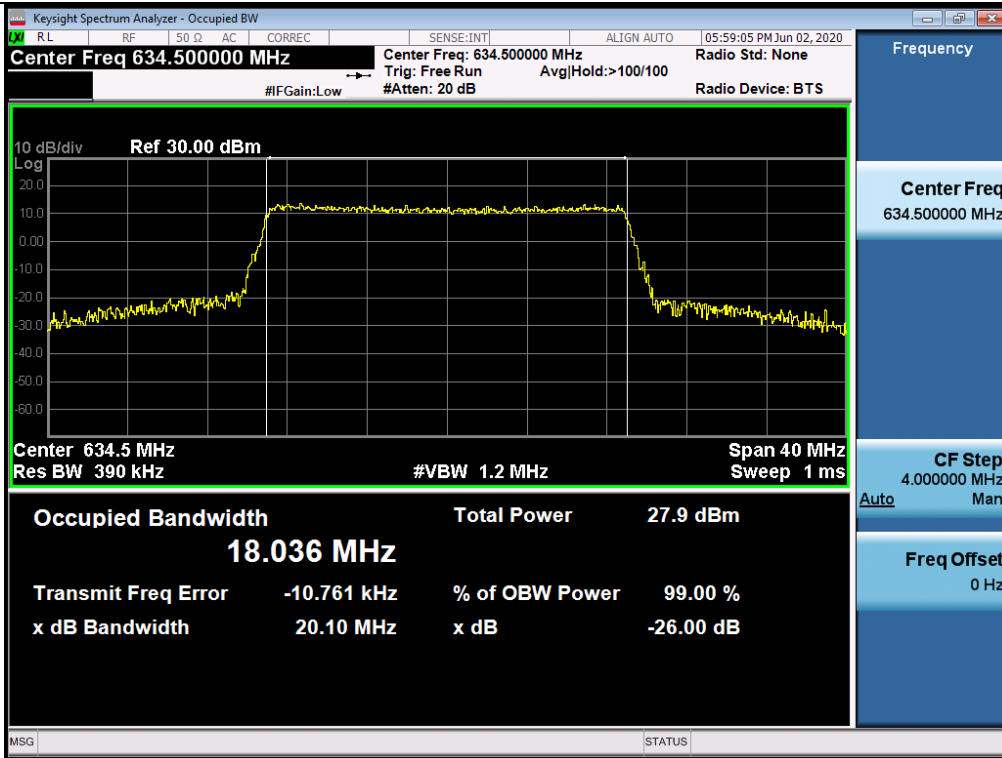

3 dB above the AGC threshold Input / 600 MHz / Downlink / LTE 20 MHz

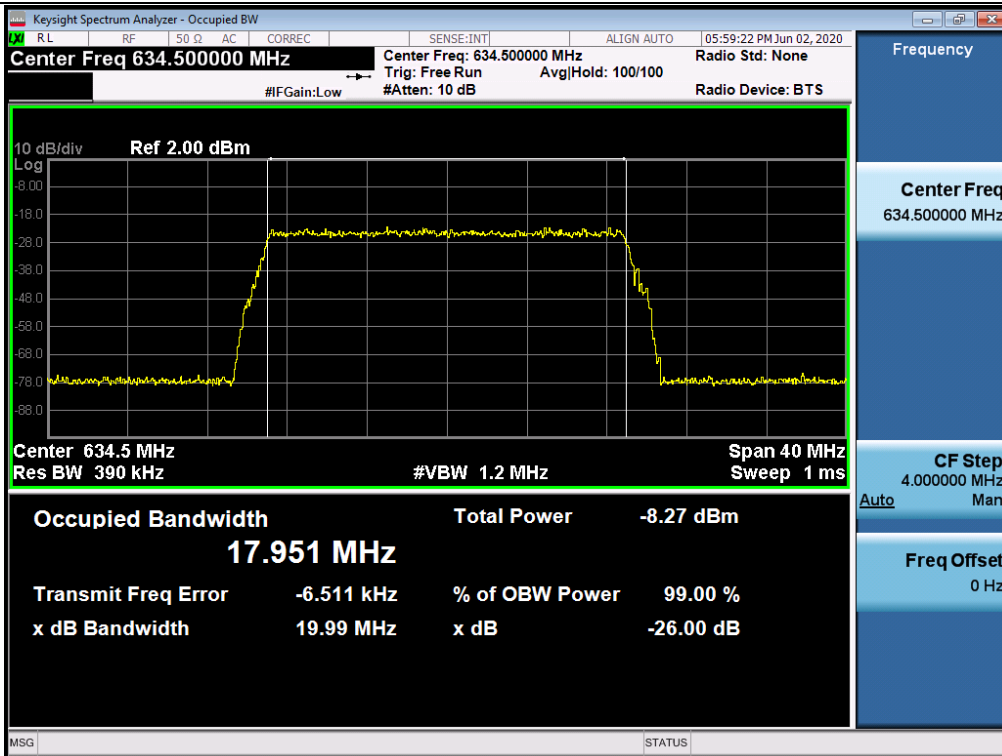

Output / ESMR / Downlink / CDMA

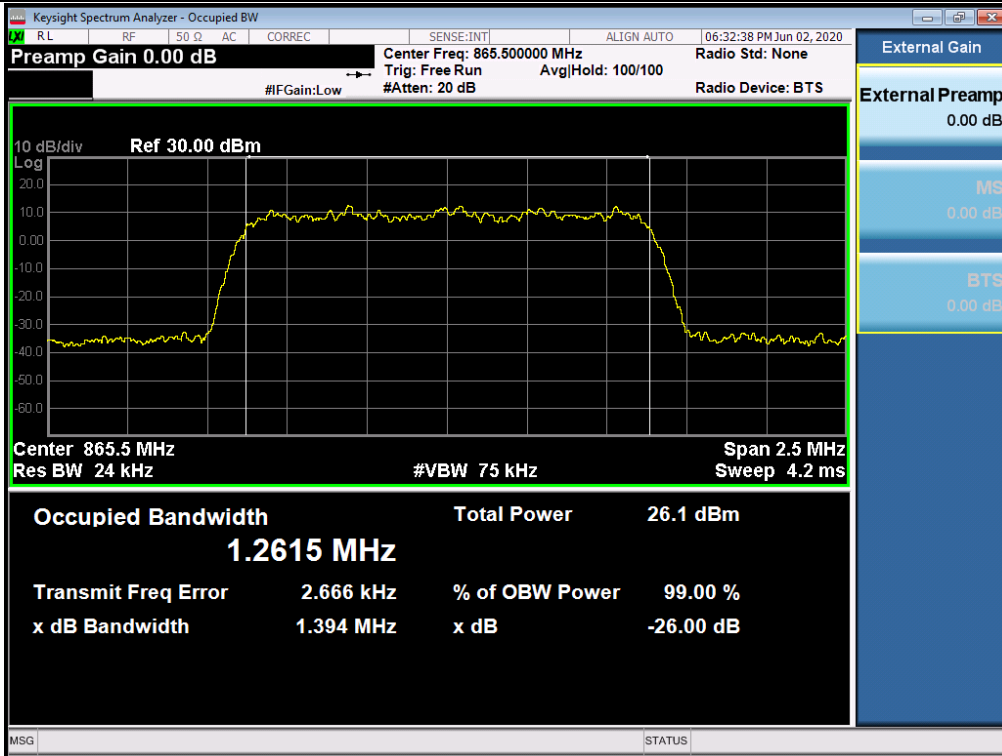

Input / ESMR / Downlink / CDMA

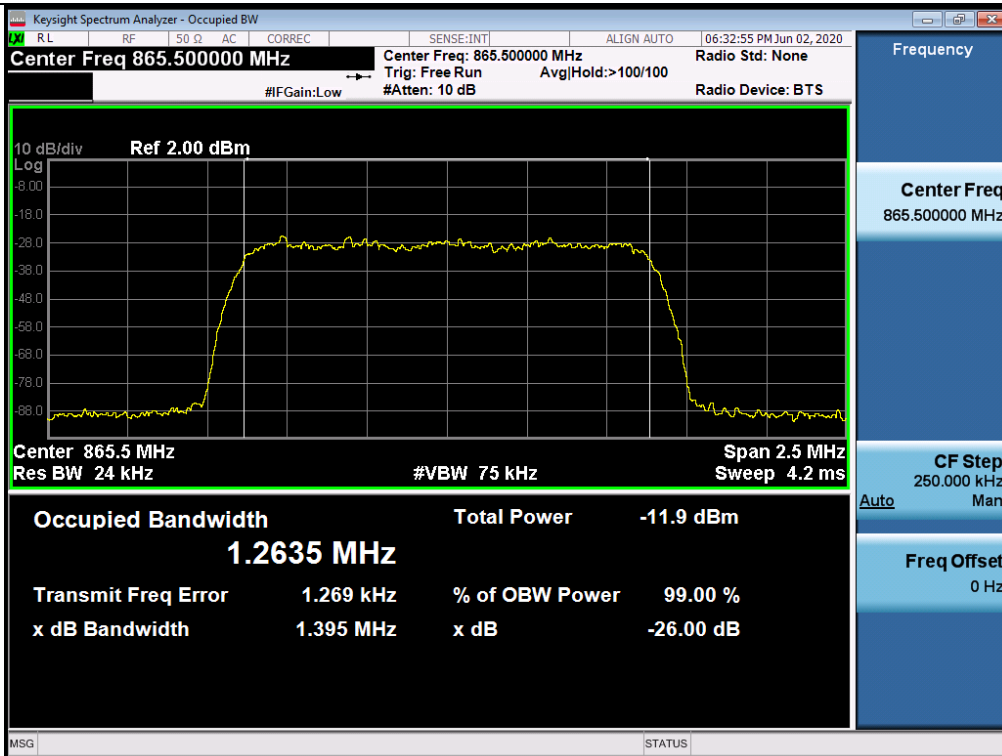

3 dB above the AGC threshold output / ESMR / Downlink / CDMA

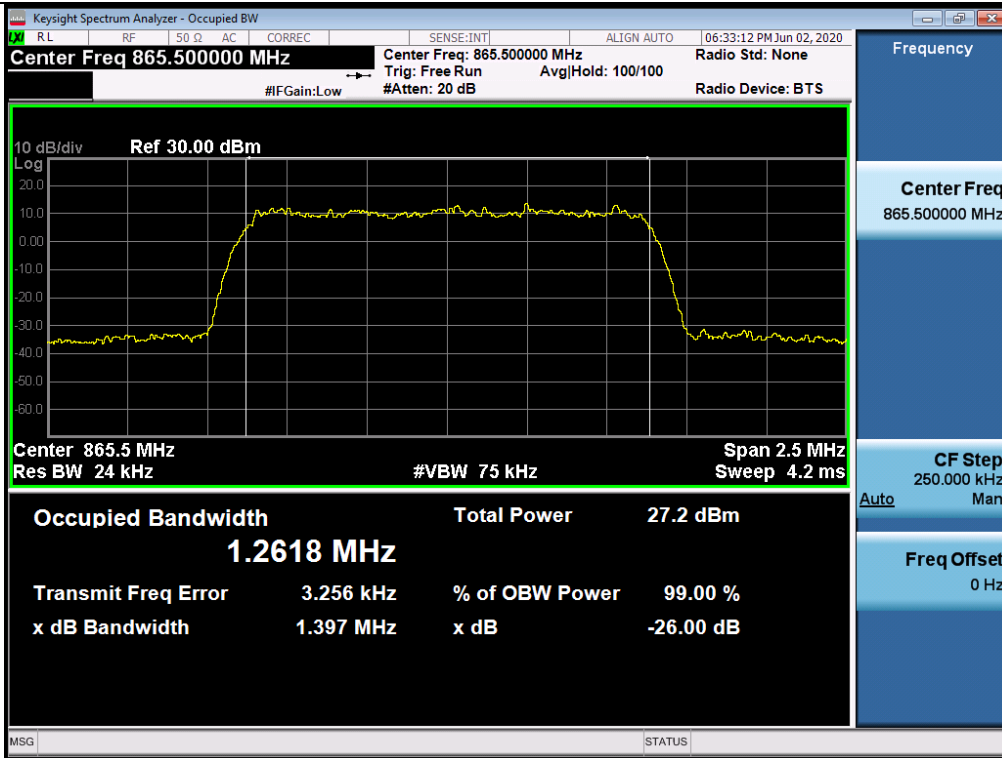

3 dB above the AGC threshold Input / ESMR / Downlink / CDMA

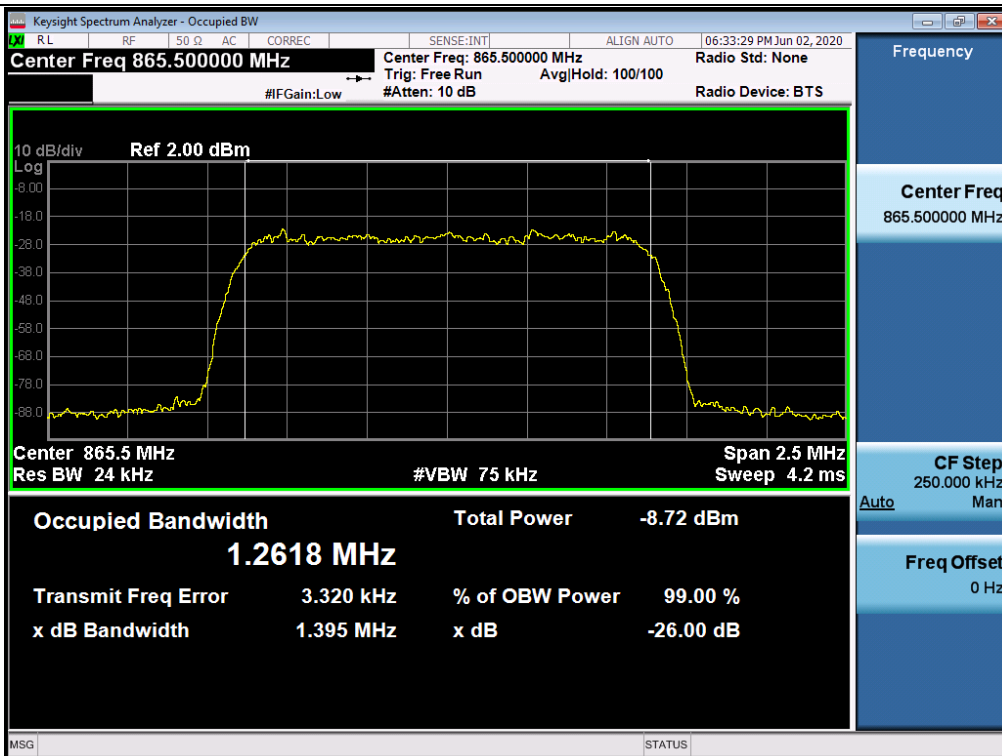

Output / ESMR / Downlink / WCDMA

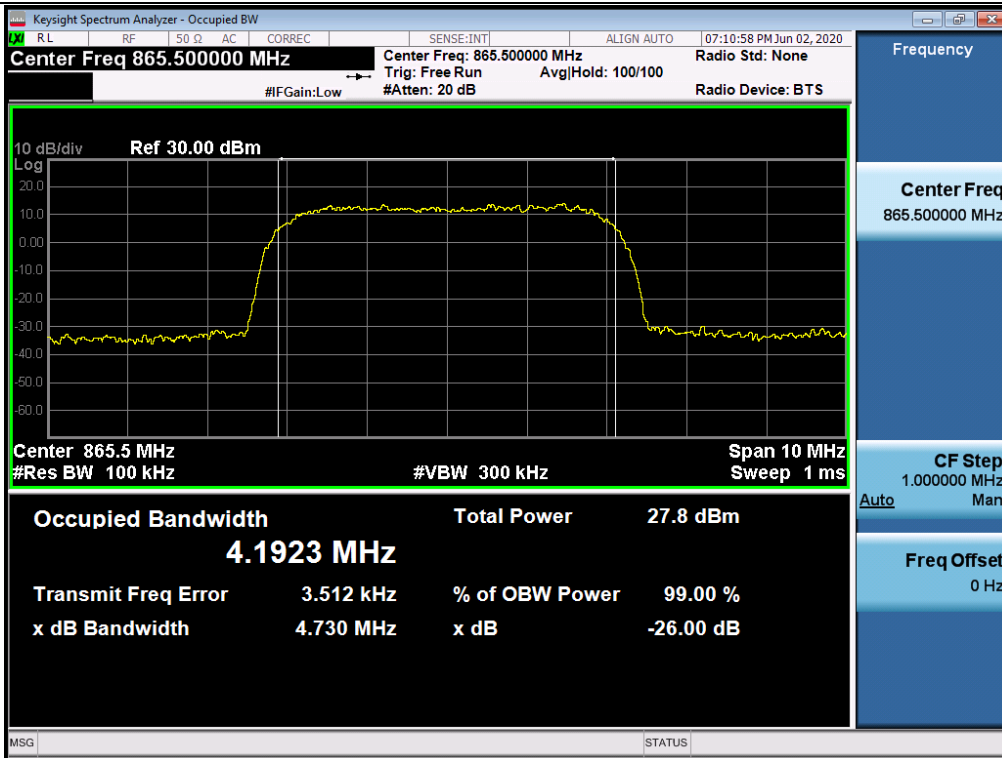

Input / ESMR / Downlink / WCDMA

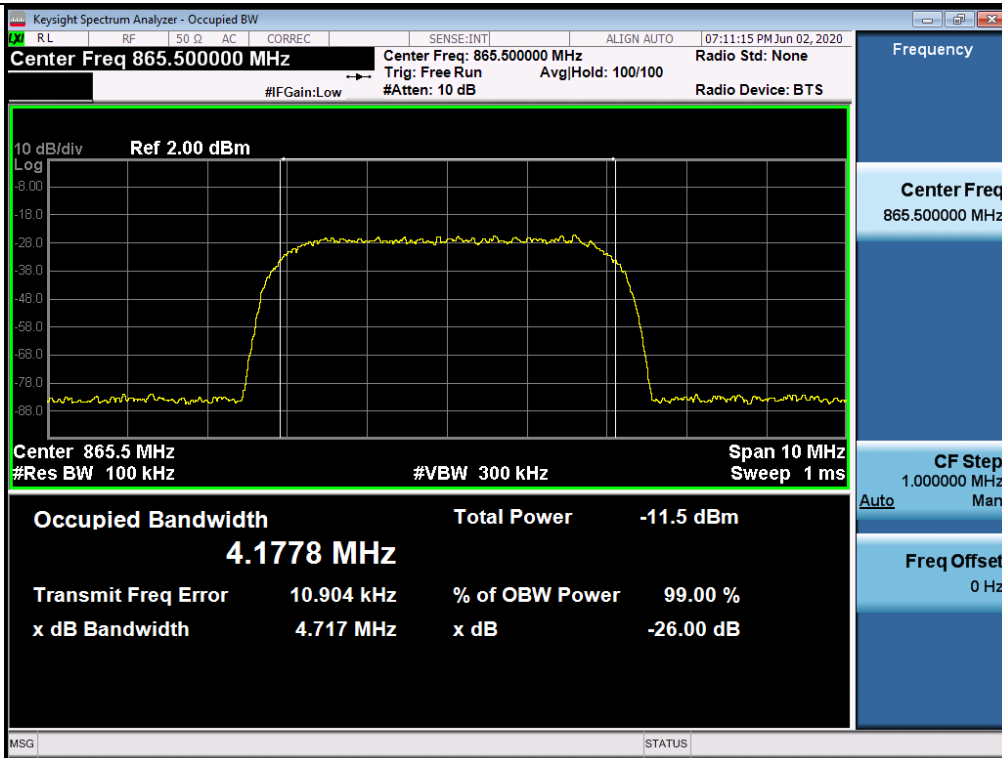

3 dB above the AGC threshold output / ESMR / Downlink / WCDMA

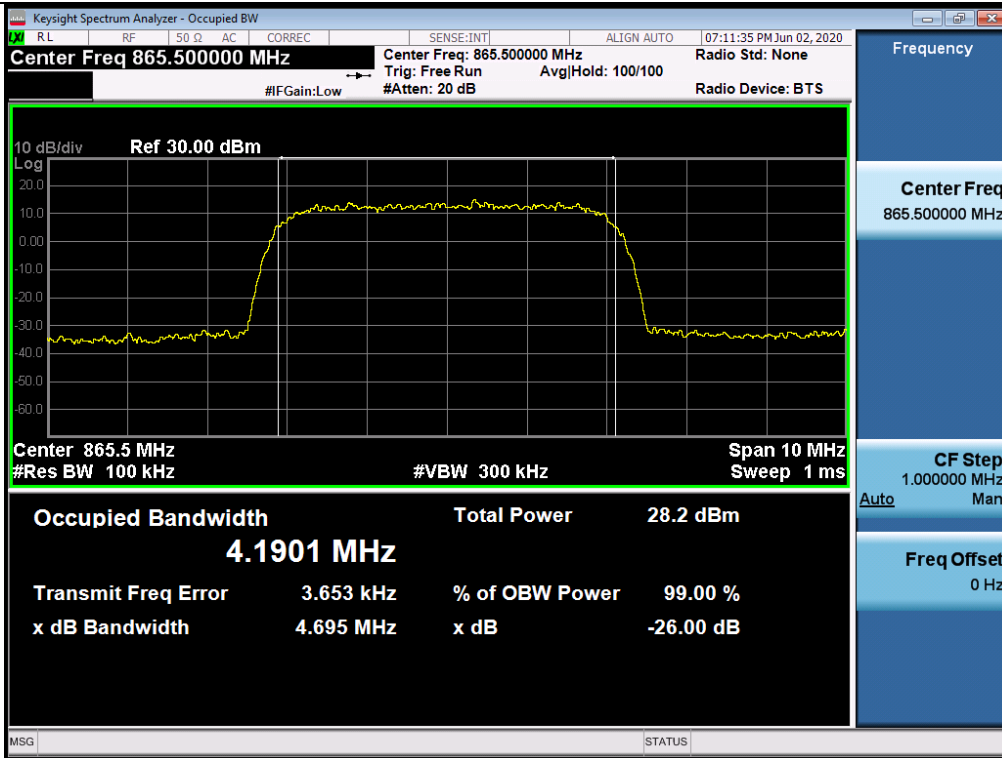

3 dB above the AGC threshold Input / ESMR / Downlink / WCDMA

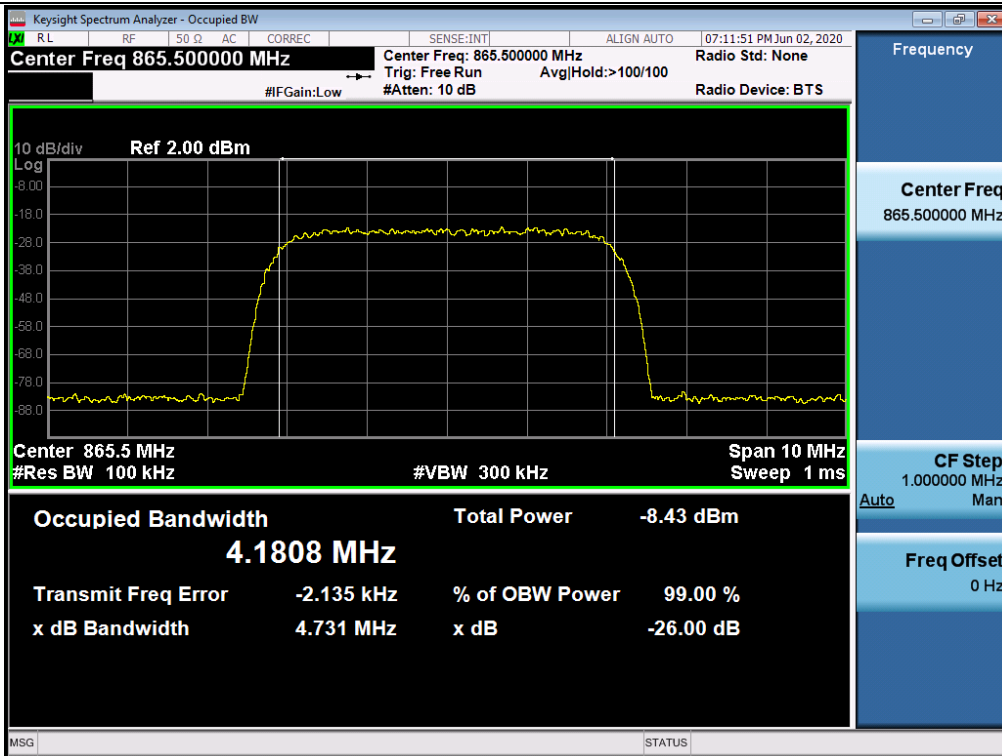

Output / ESMR / Downlink / LTE 5 MHz

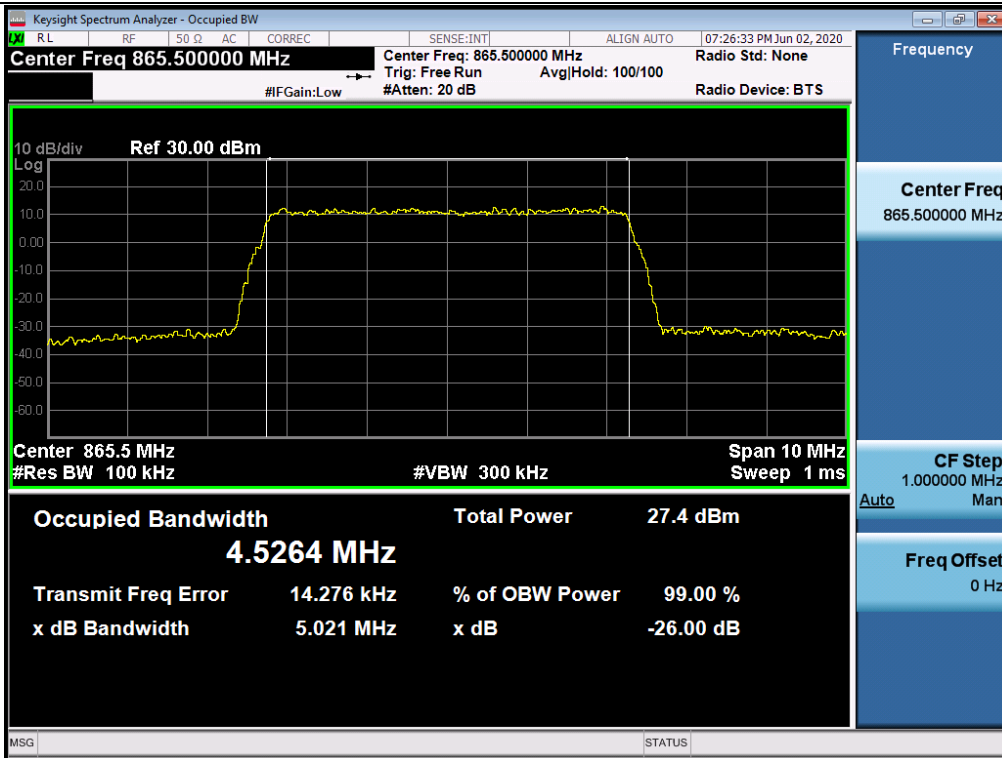

Input / ESMR / Downlink / LTE 5 MHz

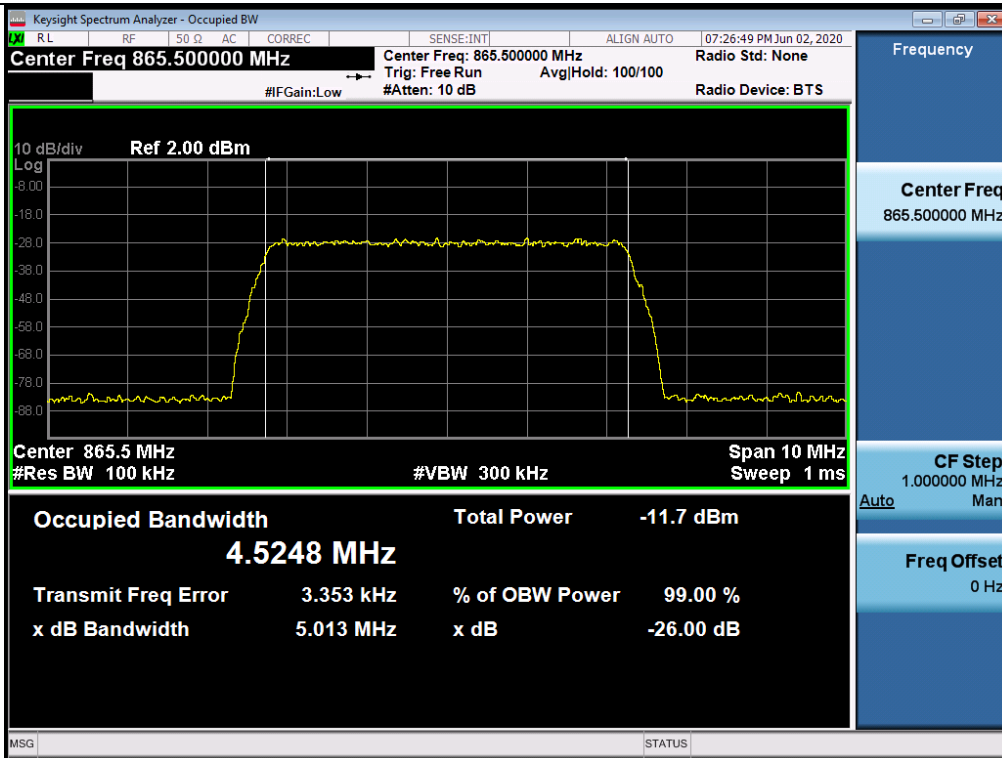

3 dB above the AGC threshold output / ESMR / Downlink / LTE 5 MHz

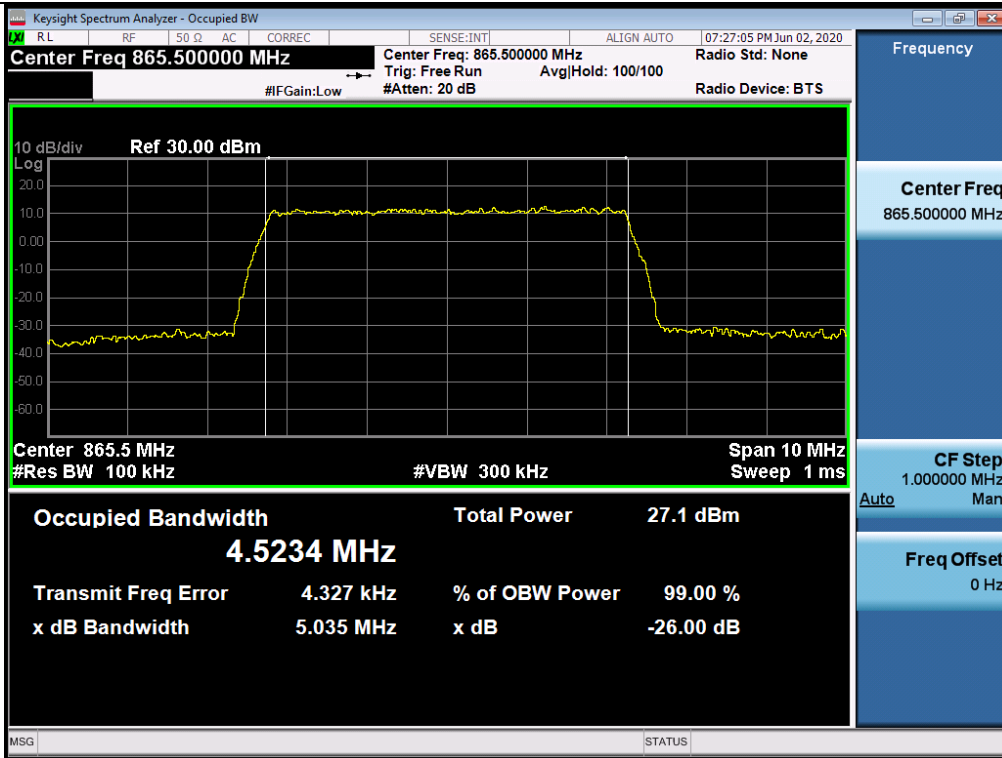

3 dB above the AGC threshold Input / ESMR / Downlink / LTE 5 MHz

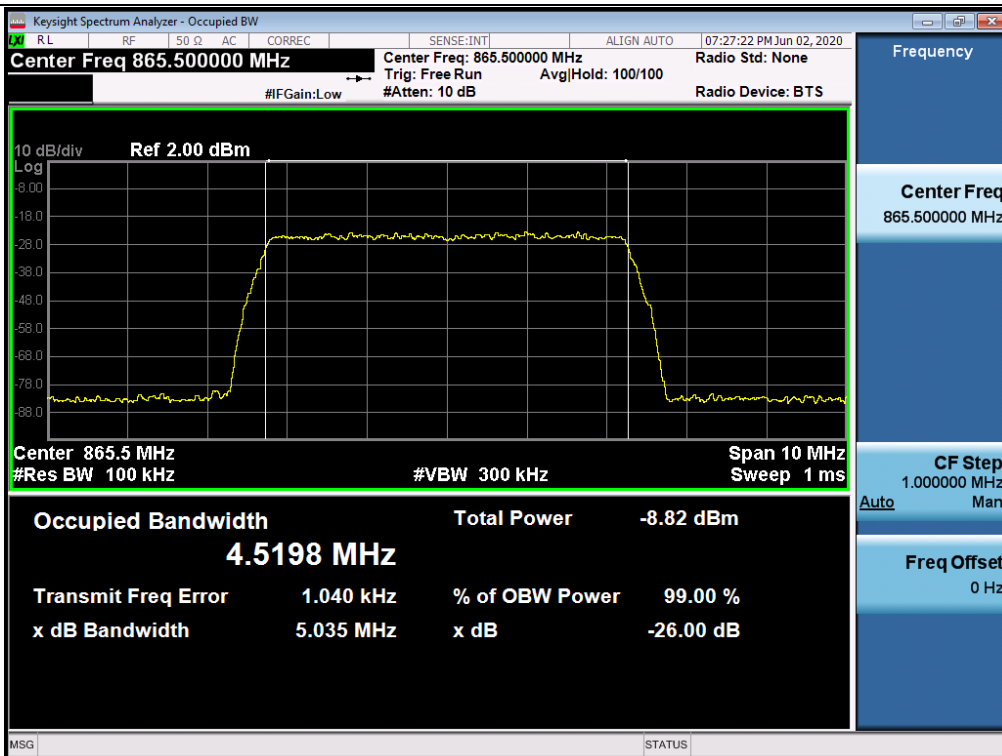

Output / Cellular / Downlink / CDMA

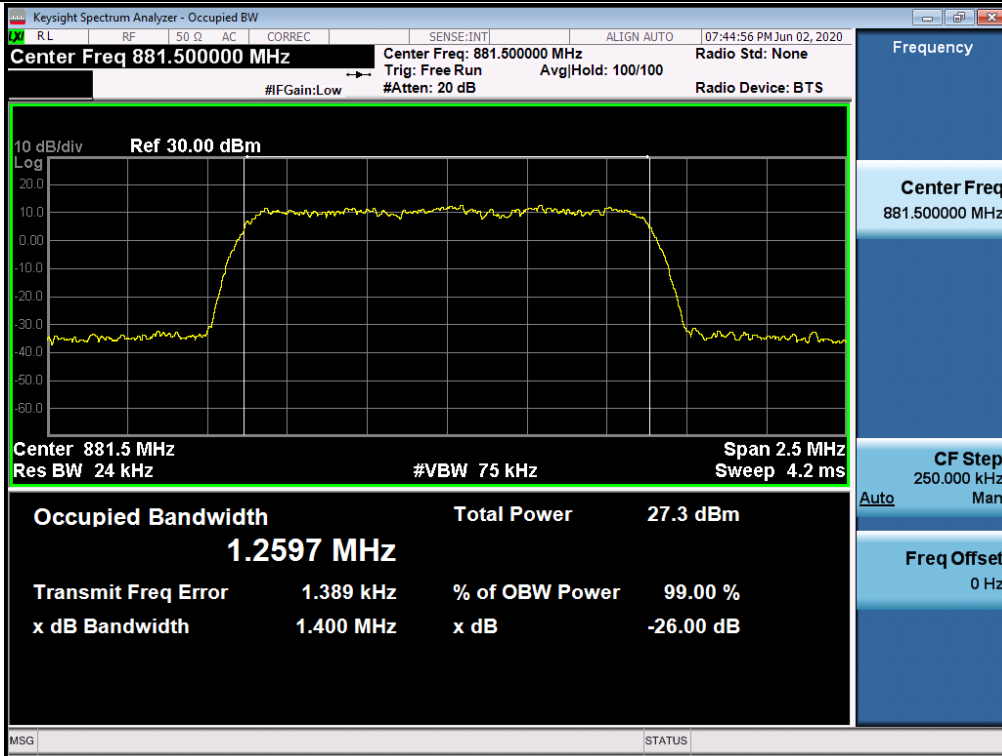

Input / Cellular / Downlink / CDMA

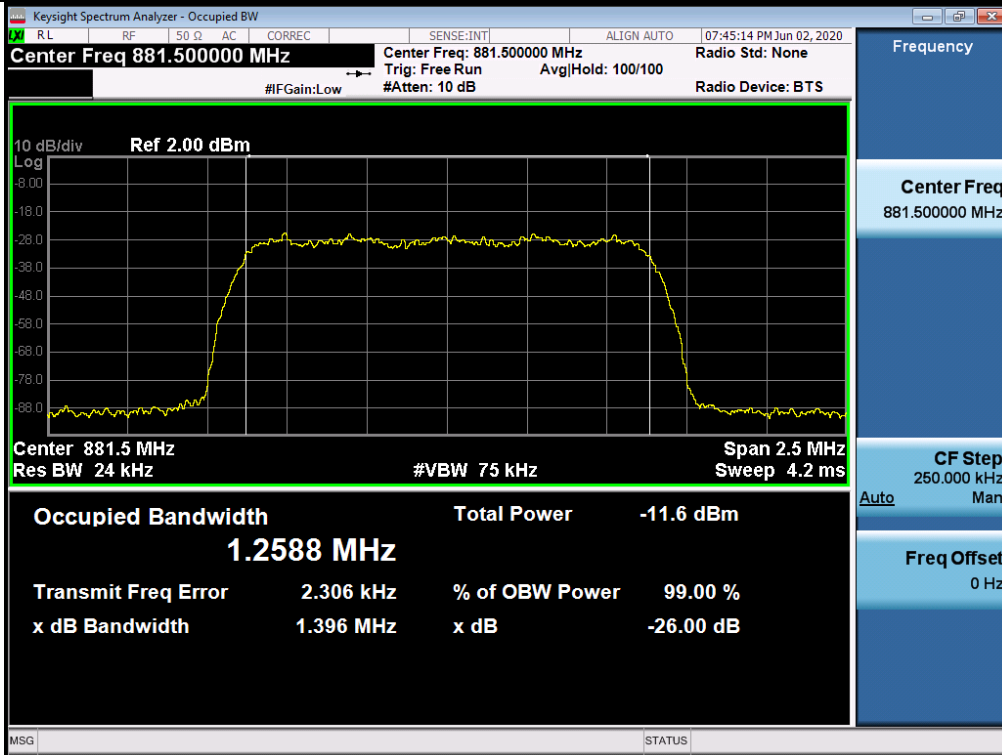

3 dB above the AGC threshold output / Cellular / Downlink / CDMA

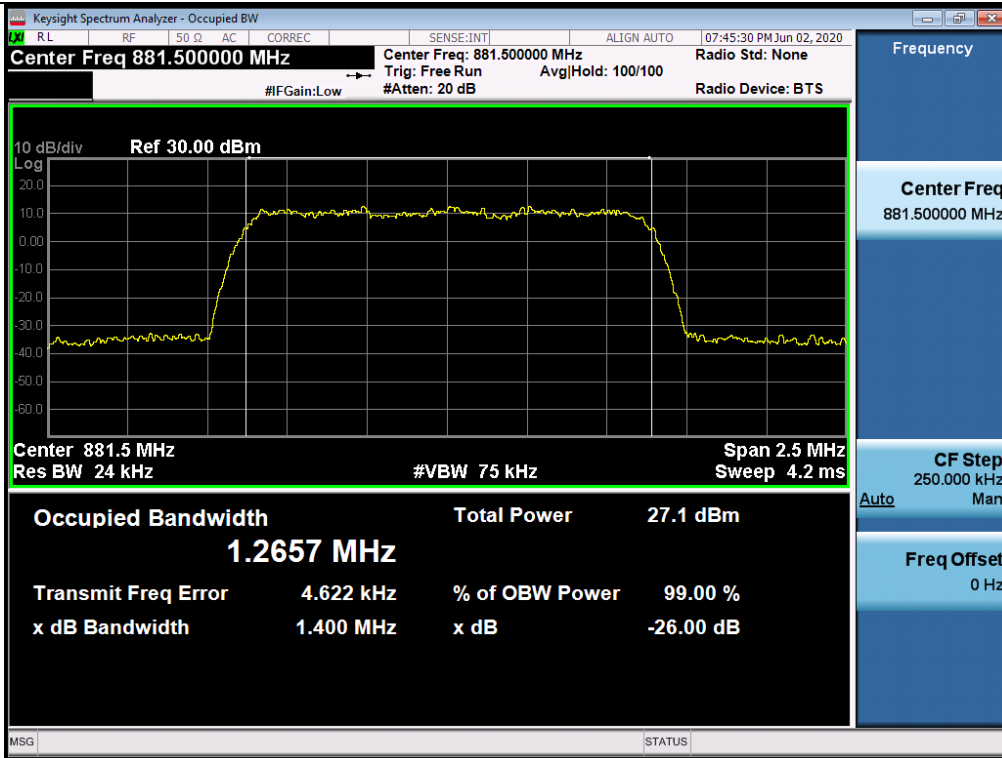

3 dB above the AGC threshold Input / Cellular / Downlink / CDMA

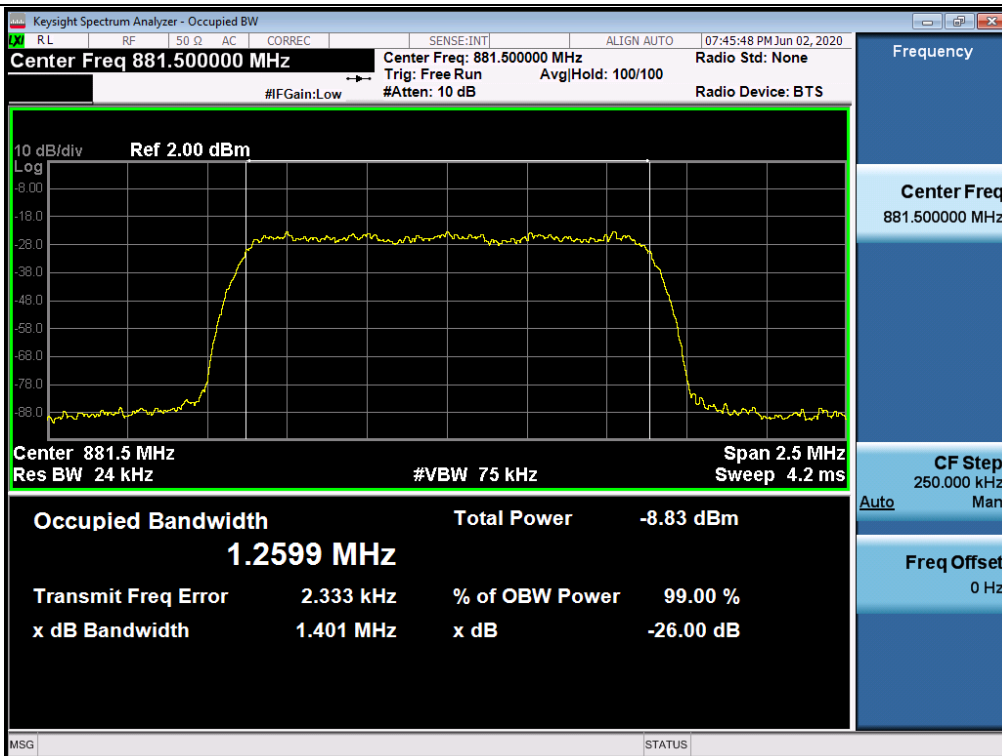

Output / Cellular / Downlink / WCDMA

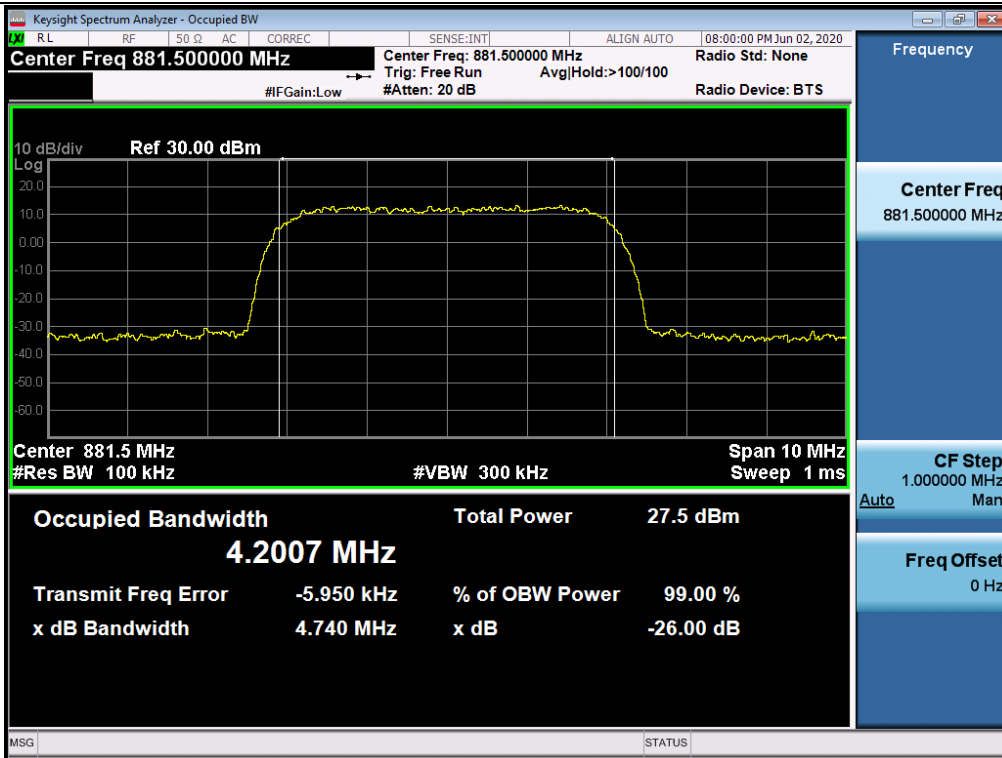

Input / Cellular / Downlink / WCDMA

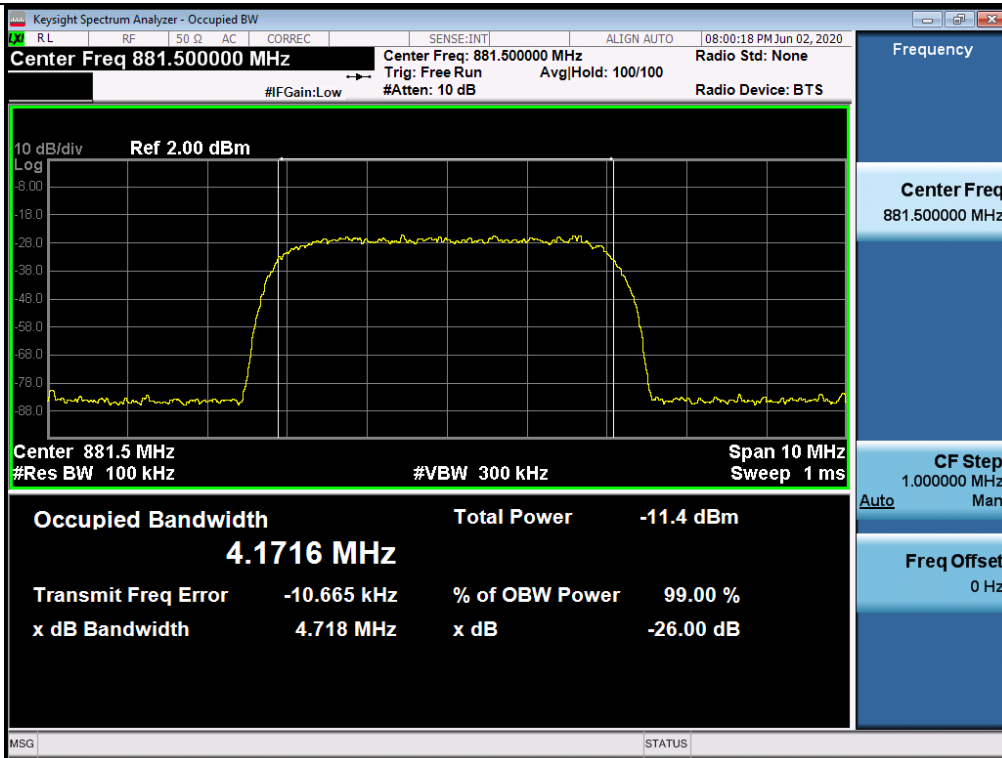

3 dB above the AGC threshold output / Cellular / Downlink / WCDMA

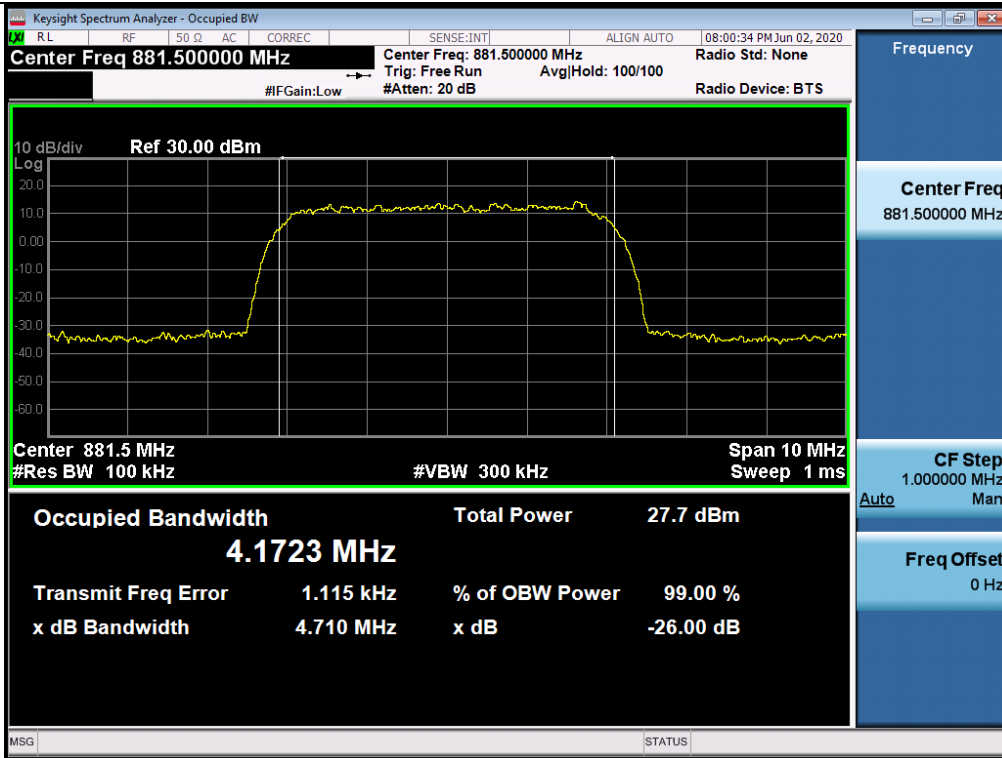

3 dB above the AGC threshold Input / Cellular / Downlink / WCDMA

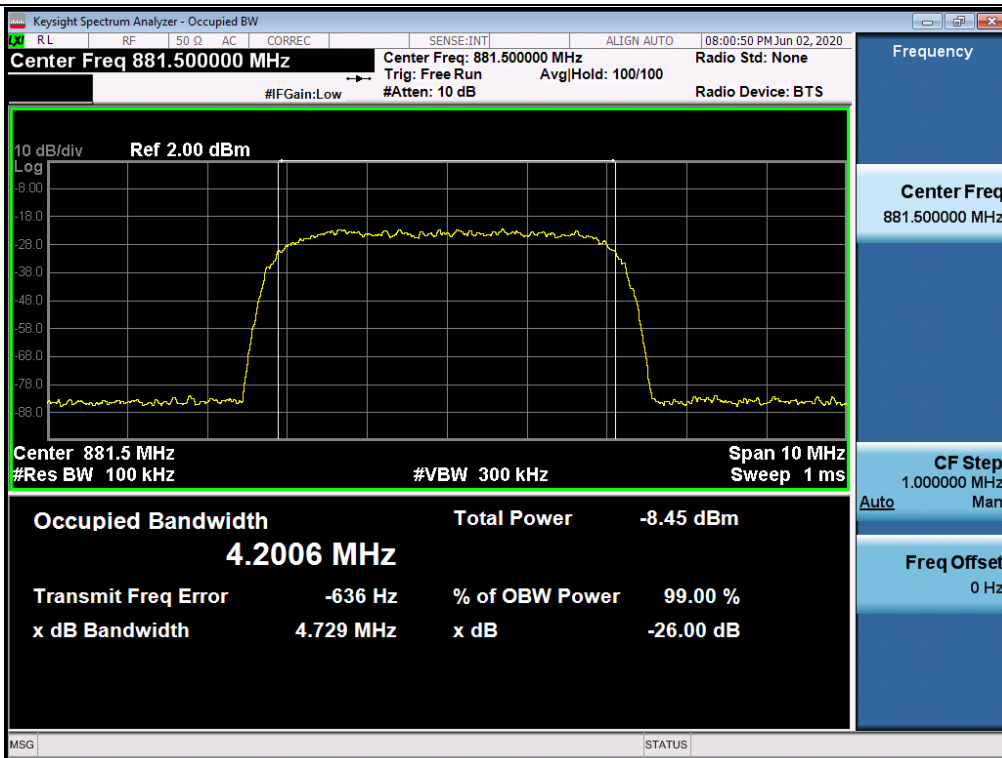

Output / Cellular / Downlink / LTE 5 MHz

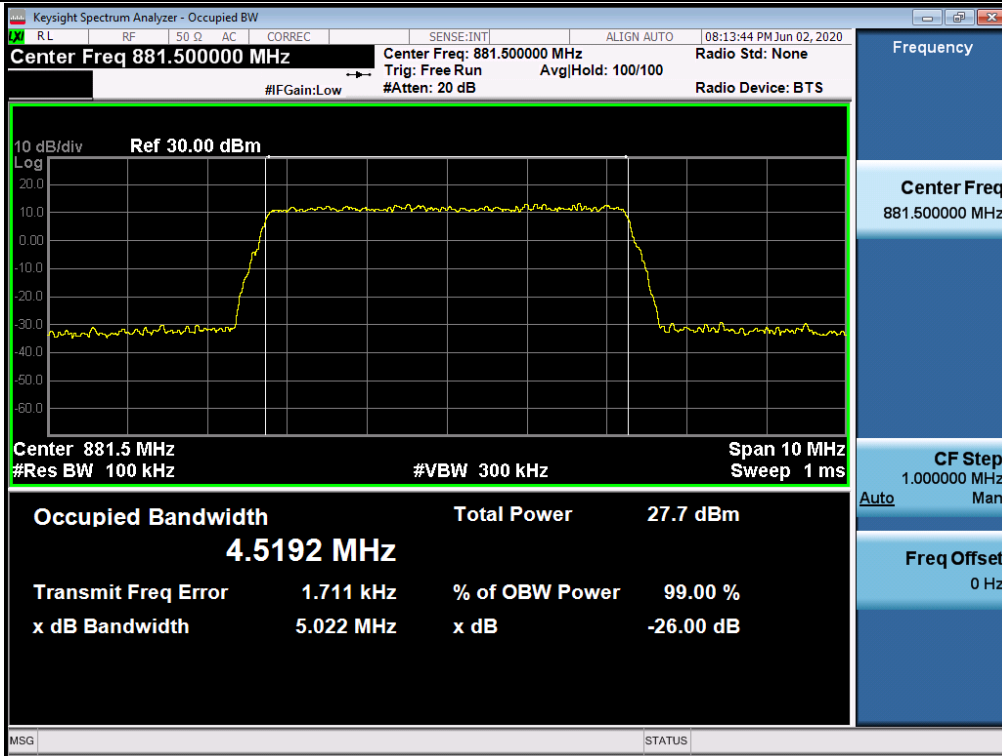

Input / Cellular / Downlink / LTE 5 MHz

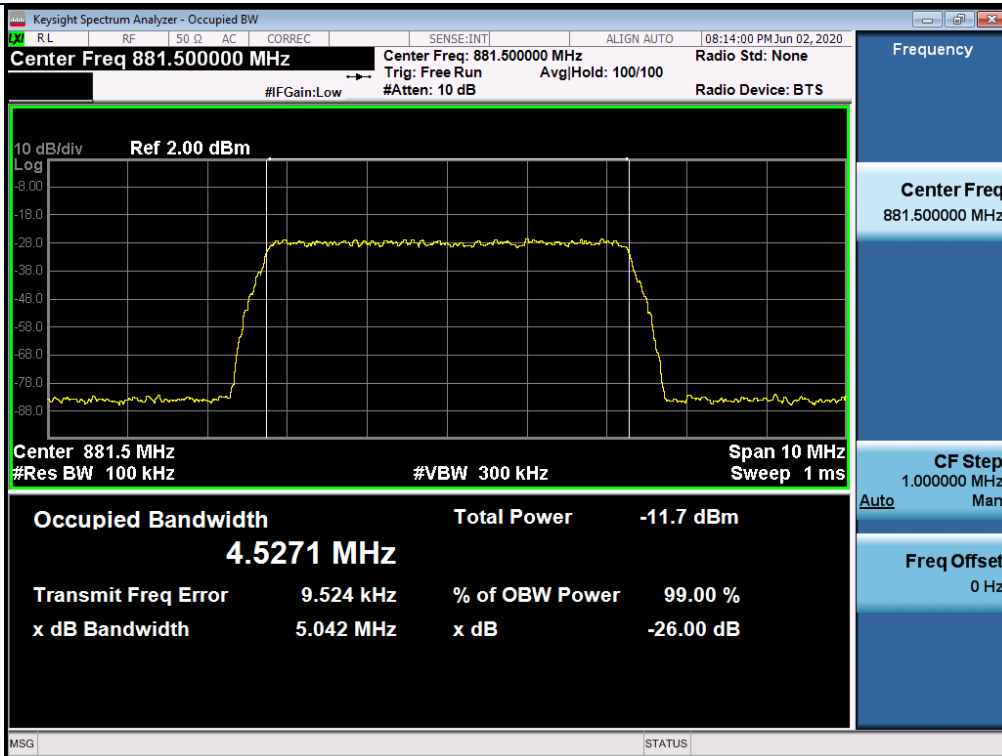

3 dB above the AGC threshold output / Cellular / Downlink / LTE 5 MHz

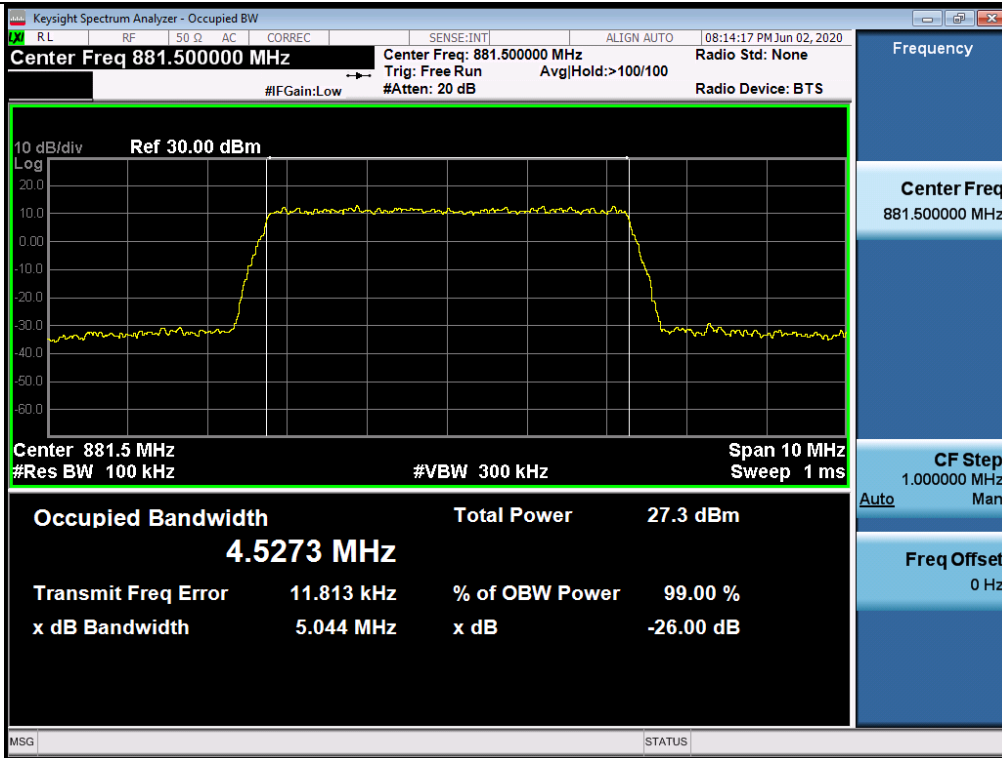

3 dB above the AGC threshold Input / Cellular / Downlink / LTE 5 MHz

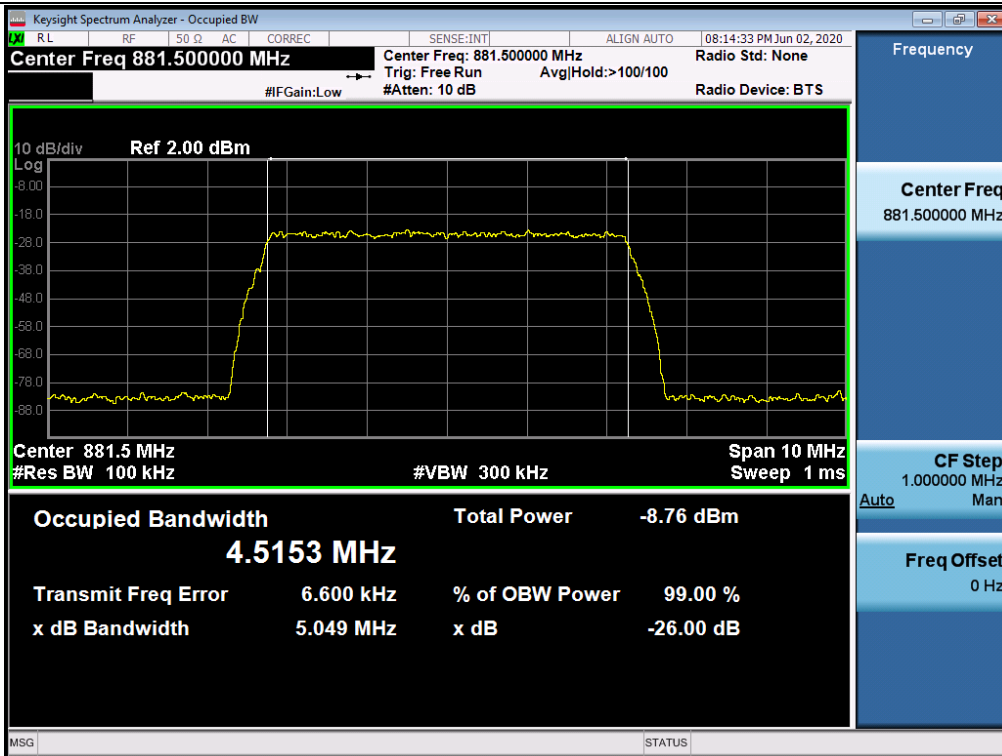

Output / Cellular / Downlink / LTE 10 MHz

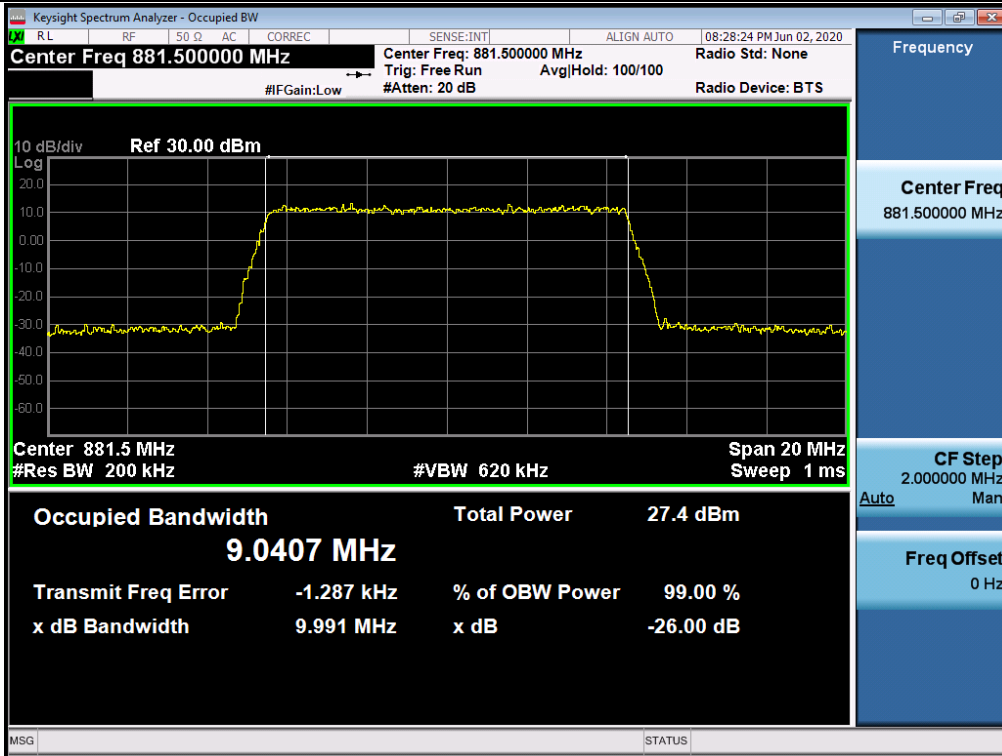

Input / Cellular / Downlink / LTE 10 MHz

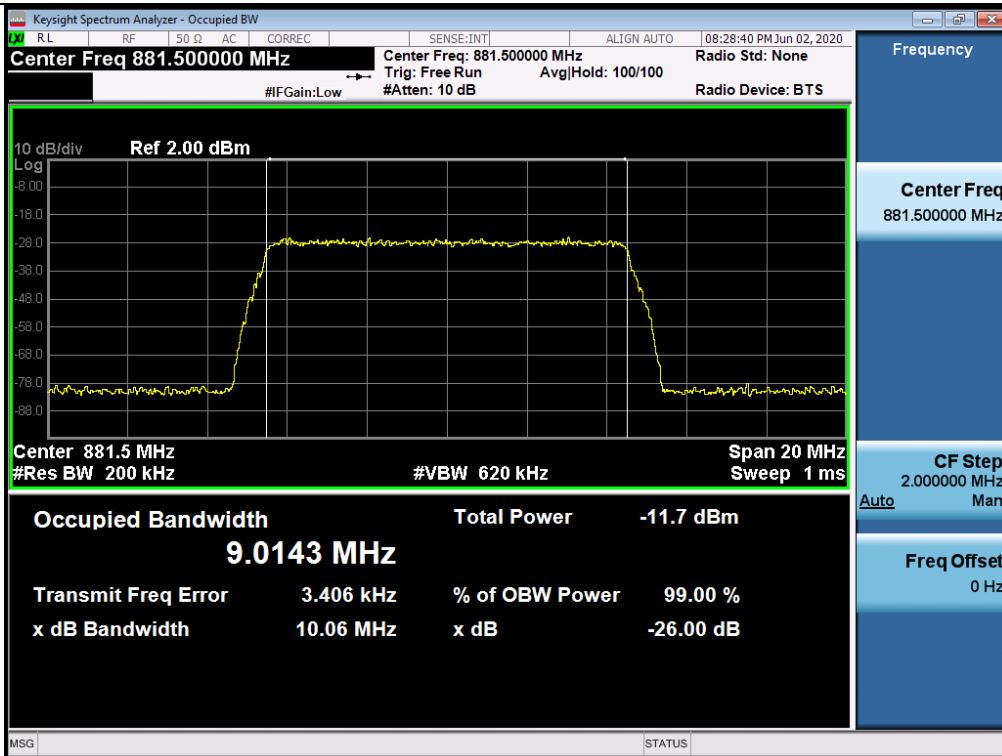

3 dB above the AGC threshold output / Cellular / Downlink / LTE 10 MHz

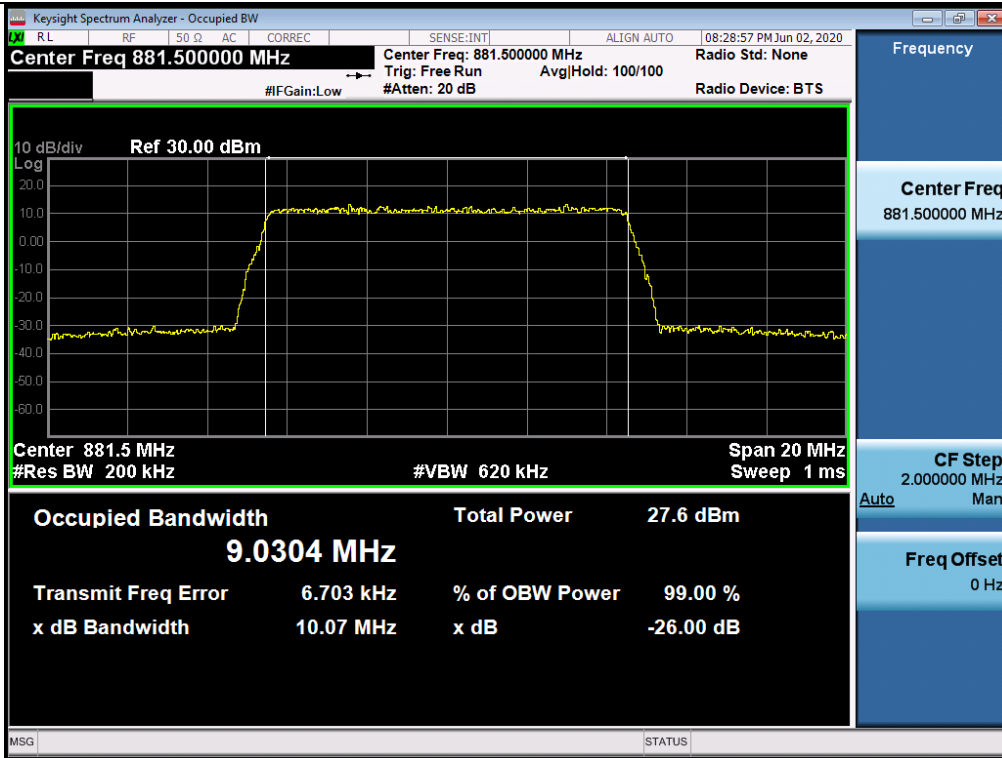

3 dB above the AGC threshold Input / Cellular / Downlink / LTE 10 MHz

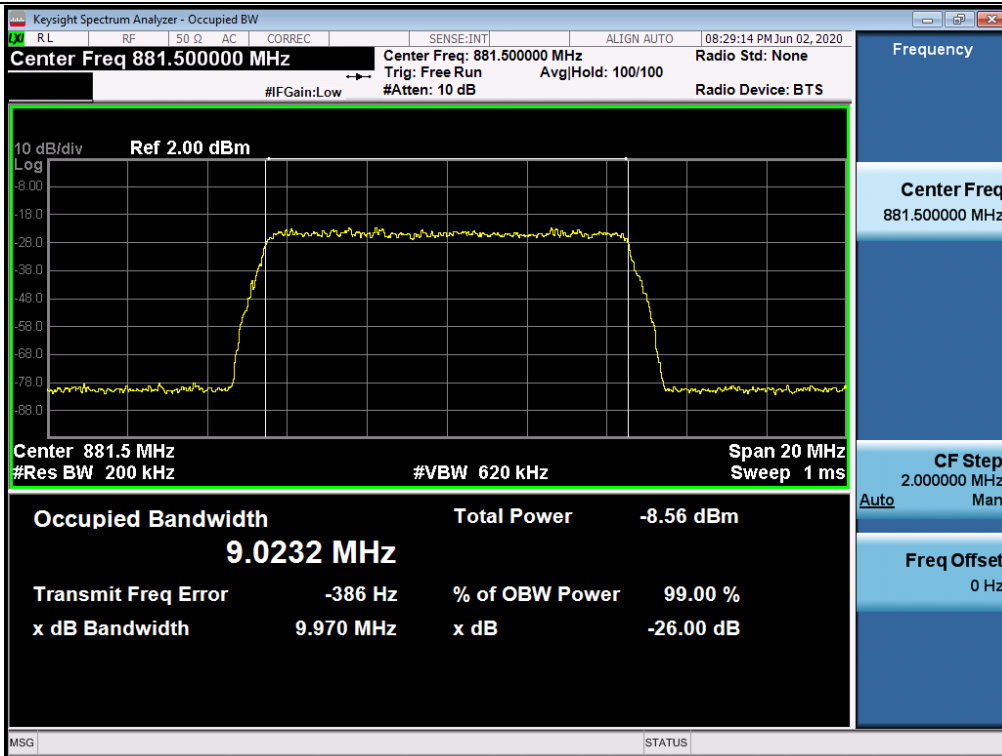

Output / WCS / Downlink / LTE 5 MHz

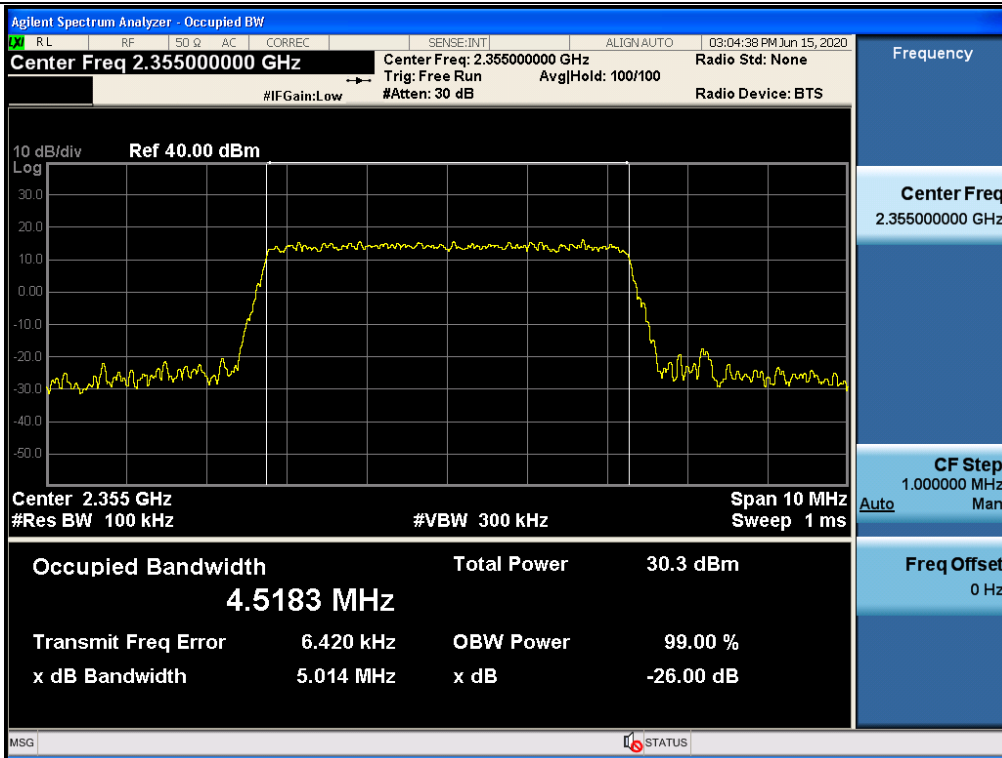

Input / WCS / Downlink / LTE 5 MHz

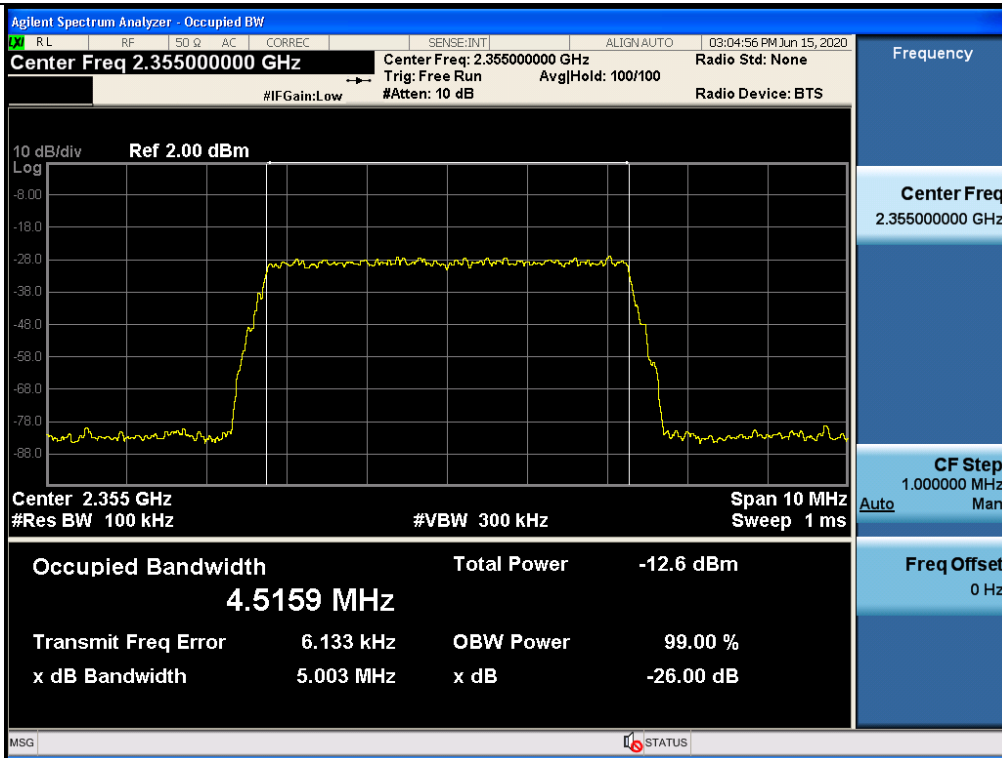

3 dB above the AGC threshold output / WCS / Downlink / LTE 5 MHz

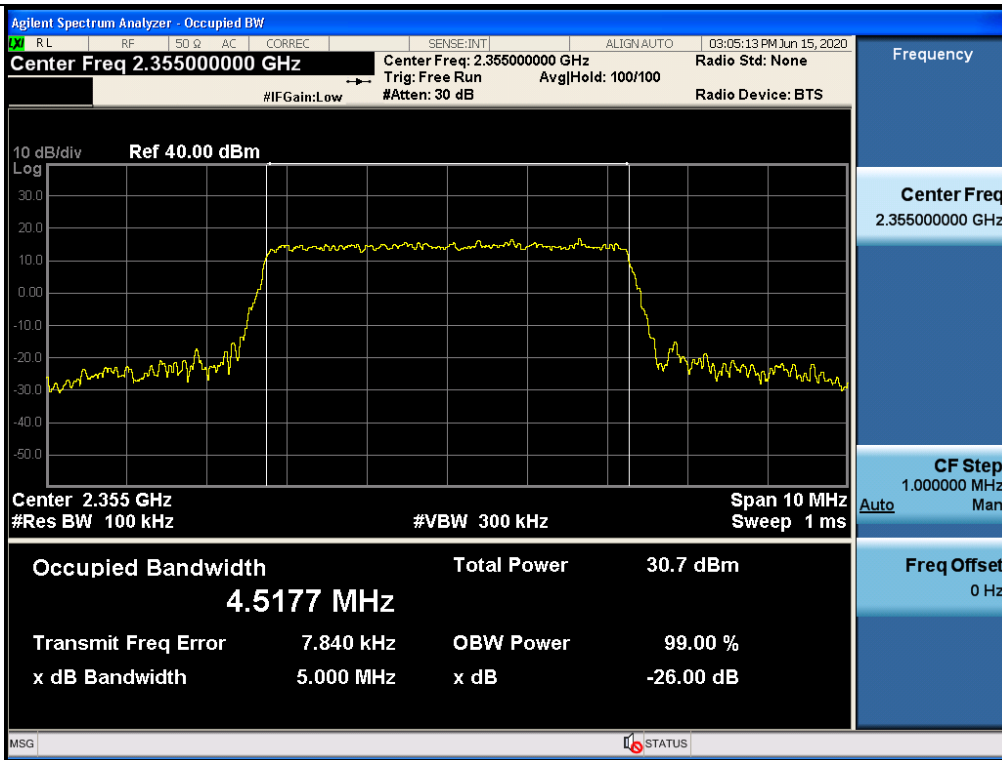

3 dB above the AGC threshold Input / WCS / Downlink / LTE 5 MHz

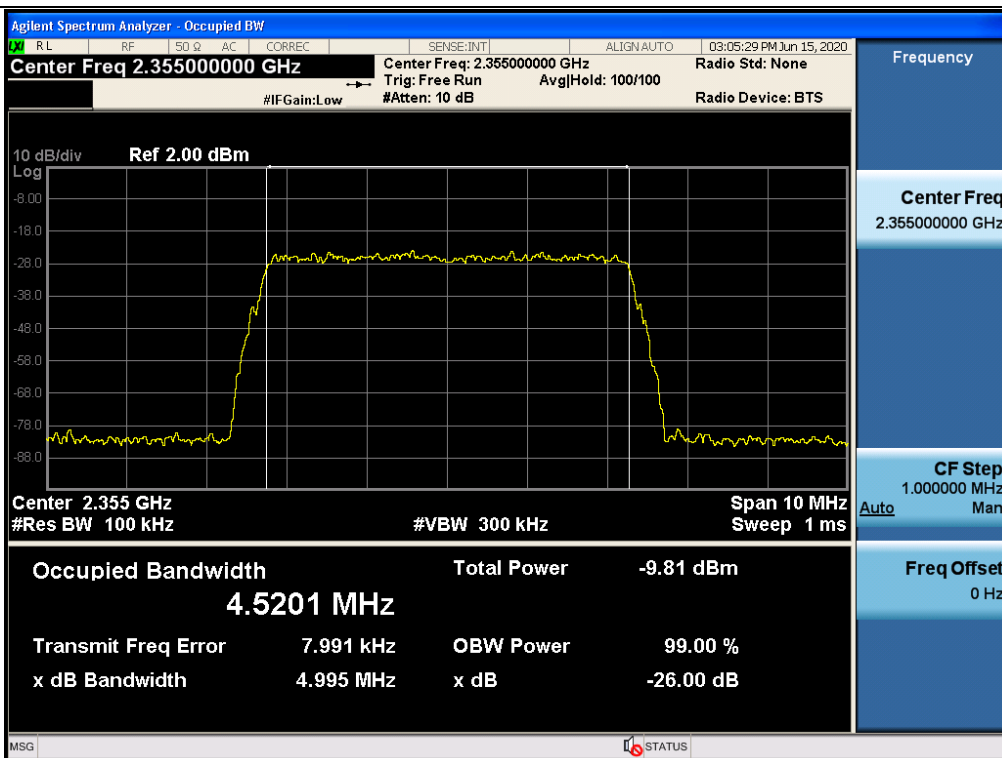

Output / WCS / Downlink / LTE 10 MHz

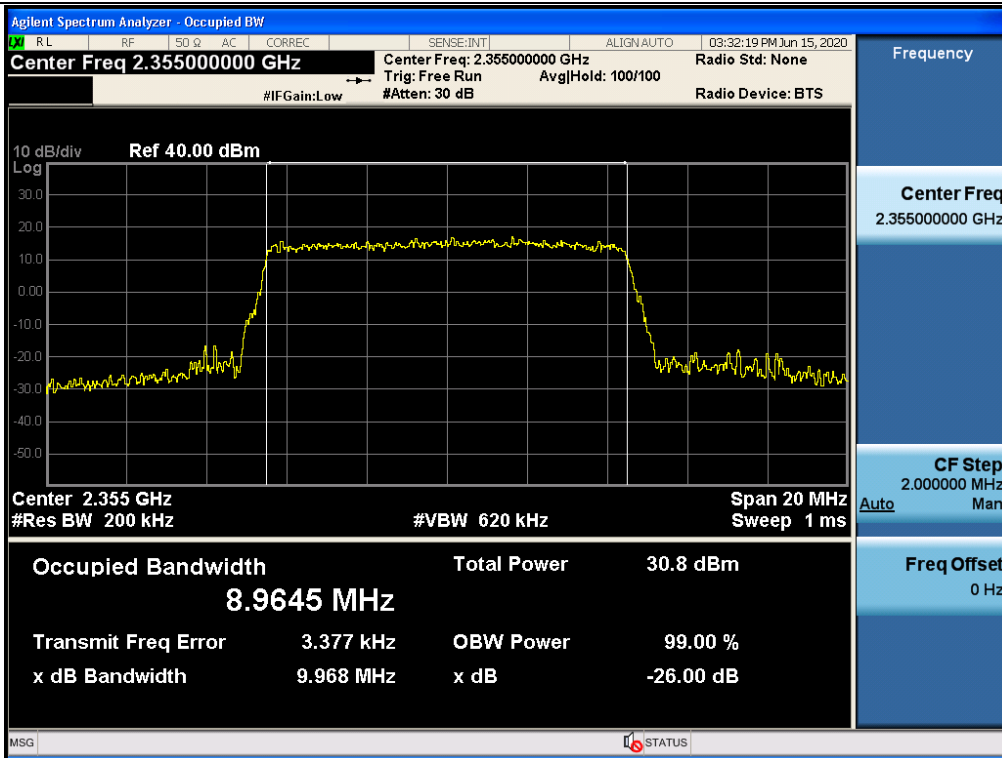

Input / WCS / Downlink / LTE 10 MHz

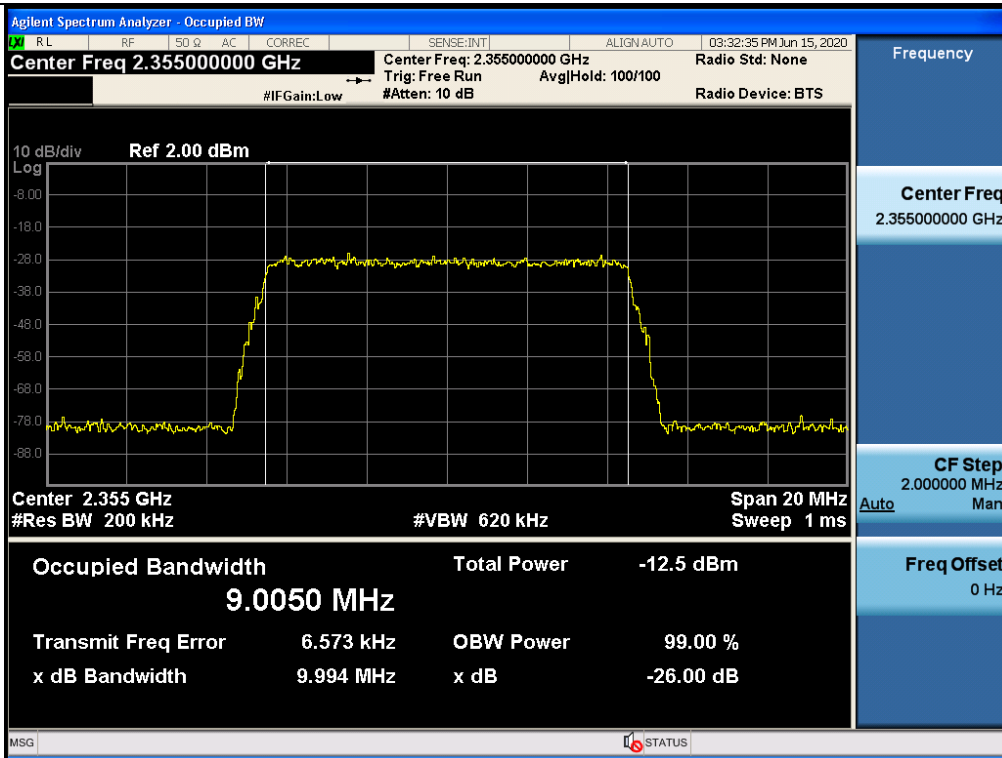

3 dB above the AGC threshold output / WCS / Downlink / LTE 10 MHz

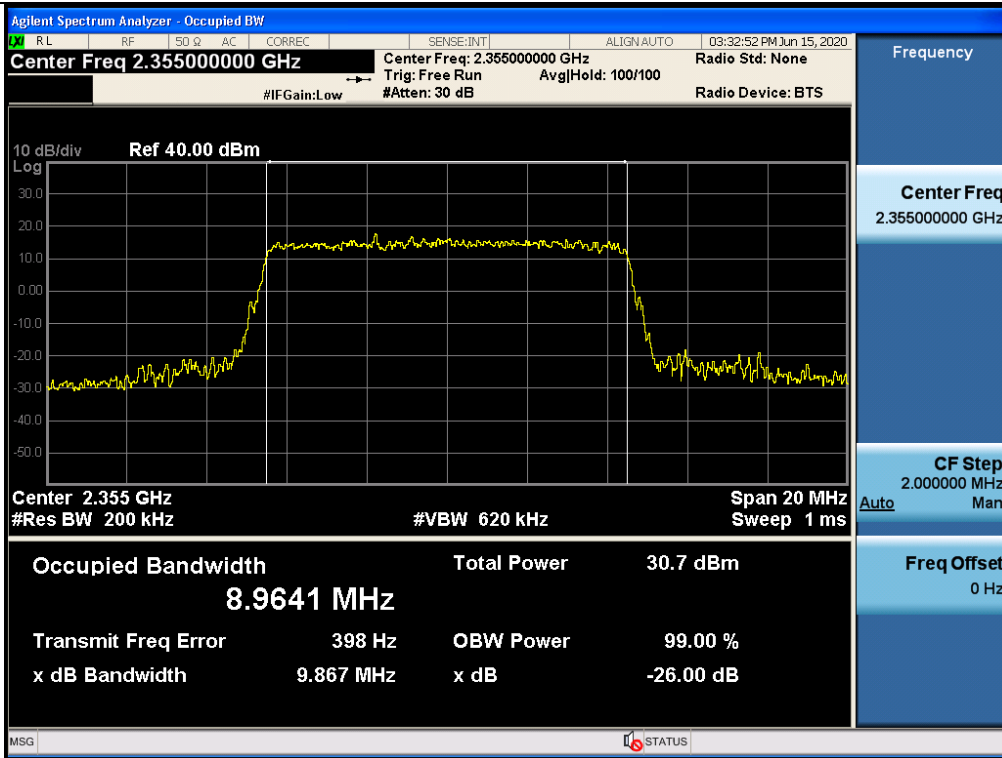

3 dB above the AGC threshold Input / WCS / Downlink / LTE 10 MHz

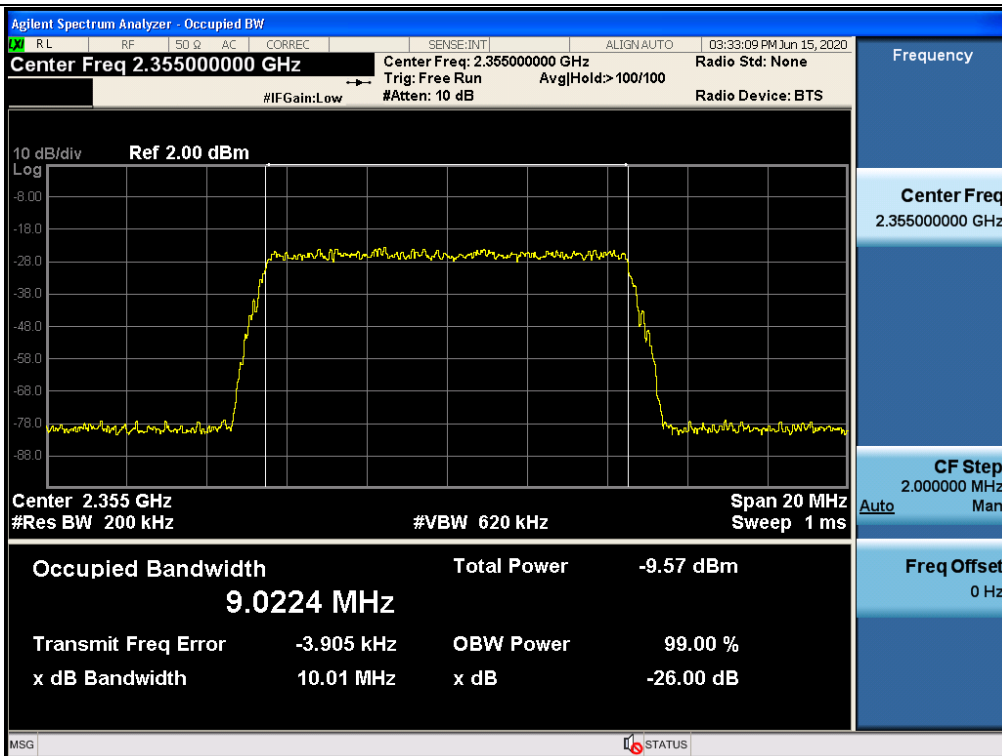

5.4. INPUT/OUTPUT POWER AND AMPLIFIER/BOOSTER GAIN

Test Requirement:

§ 2.1046 Measurements required: RF power output.

(a) For transmitters other than single sideband, independent sideband and controlled carrier radiotelephone, power output shall be measured at the RF output terminals when the transmitter is adjusted in accordance with the tune-up procedure to give the values of current and voltage on the circuit elements specified in § 2.1033(c)(8). The electrical characteristics of the radio frequency load attached to the output terminals when this test is made shall be stated.

(b) For single sideband, independent sideband, and single channel, controlled carrier radiotelephone transmitters the procedure specified in paragraph (a) of this section shall be employed and, in addition, the transmitter shall be modulated during the test as specified and applicable in § 2.1046 (b) (1-5). In all tests, the input level of the modulating signal shall be such as to develop rated peak envelope power or carrier power, as appropriate, for the transmitter.

(c) For measurements conducted pursuant to paragraphs (a) and (b) of this section, all calculations and methods used by the applicant for determining carrier power or peak envelope power, as appropriate, on the basis of measured power in the radio frequency load attached to the transmitter output terminals shall be shown. Under the test conditions specified, no components of the emission spectrum shall exceed the limits specified in the applicable rule parts as necessary for meeting occupied bandwidth or emission limitations.

§ 22.913 Effective radiated power limits.

Licensees in the Cellular Radiotelephone Service are subject to the effective radiated power (ERP) limits and other requirements in this Section. See also § 22.169.

(a) *Maximum ERP.* The ERP of transmitters in the Cellular Radiotelephone Service must not exceed the limits in this section.

(1) Except as described in paragraphs (a)(2), (3), and (4) of this section, the ERP of base stations and repeaters must not exceed—

- (i) 500 watts per emission; or
- (ii) 400 watts/MHz (PSD) per sector.

(d) Power measurement. Measurement of the ERP of Cellular base transmitters and repeaters must be made using an average power measurement technique. The peak-to-average ratio (PAR) of the transmission must not exceed 13 dB. Power measurements for base transmitters and repeaters must be made in accordance with either of the following:

- (1) A Commission-approved average power technique (see FCC Laboratory's Knowledge Database); or
- (2) For purposes of this section, peak transmit power must be measured over an interval of continuous transmission using instrumentation calibrated in terms of an rms-equivalent voltage. The measurement results shall be properly adjusted for any instrument limitations, such as detector response times, limited resolution bandwidth capability when compared to the emission bandwidth, sensitivity, etc., so as to obtain a true peak measurement for the emission in question over the full bandwidth of the channel.

§ 27.50 Power limits and duty cycle.

(a) The following power limits and related requirements apply to stations transmitting in the 2305-2320 MHz band or the 2345-2360 MHz band.

(1) Base and fixed stations.

(i) For base and fixed stations transmitting in the 2305-2315 MHz band or the 2350-2360 MHz band:

(A) The average equivalent isotropically radiated power (EIRP) must not exceed 2,000 watts within any 5 megahertz of authorized bandwidth and must not exceed 400 watts within any 1 megahertz of authorized bandwidth.

(B) The peak-to-average power ratio (PAPR) of the transmitter output power must not exceed 13 dB. The PAPR measurements should be made using either an instrument with complementary cumulative distribution function (CCDF) capabilities to determine that PAPR will not exceed 13 dB for more than 0.1 percent of the time or other Commission approved procedure. The measurement must be performed using a signal corresponding to the highest PAPR expected during periods of continuous transmission.

(ii) For base and fixed stations transmitting in the 2315-2320 MHz band or the 2345-2350 MHz band, the peak EIRP must not exceed 2,000 watts.

(c) The following power and antenna height requirements apply to stations transmitting in the 600 MHz band and the 698-746 MHz band:

(3) Fixed and base stations transmitting a signal with an emission bandwidth greater than 1 MHz must not exceed an ERP of 1000 watts/MHz and an antenna height of 305 m HAAT, except that antenna heights greater than 305 m HAAT are permitted if power levels are reduced below 1000 watts/MHz ERP in accordance with Table 3 of this section;

(4) Fixed and base stations located in a county with population density of 100 or fewer persons per square mile, based upon the most recently available population statistics from the Bureau of the Census, and transmitting a signal with an emission bandwidth greater than 1 MHz must not exceed an ERP of 2000 watts/MHz and an antenna height of 305 m HAAT, except that antenna heights greater than 305 m HAAT are permitted if power levels are reduced below 2000 watts/MHz ERP in accordance with Table 4 of this section;

(5) Licensees, except for licensees operating in the 600 MHz downlink band, seeking to operate a fixed or base station located in a county with population density of 100 or fewer persons per square mile, based upon the most recently available population statistics from the Bureau of the Census, and transmitting a signal at an ERP greater than 1000 watts must:

(i) Coordinate in advance with all licensees authorized to operate in the 698-758 MHz, 775-788, and 805-806 MHz bands within 120 kilometers (75 miles) of the base or fixed station;

(ii) coordinate in advance with all regional planning committees, as identified in § 90.527 of this chapter, with jurisdiction within 120 kilometers (75 miles) of the base or fixed station.



§ 90.635 Limitations on power and antenna height

(a) The effective radiated power and antenna height for base stations may not exceed 1 kilowatt (30 dBw) and 304 m. (1,000 ft.) above average terrain (AAT), respectively, or the equivalent thereof as determined from the Table.

These are maximum values, and applicants will be required to justify power levels and antenna heights requested.

(b) The maximum output power of the transmitter for mobile stations is 100 watts (20 dBw).

Table—Equivalent Power and Antenna Heights for Base Stations in the 851-869 MHz and 935-940 MHz Bands Which Have a Requirement for a 32 km (20 mi) Service Area Radius

Antenna height (ATT) meters (feet)	Effective radiated power (watts)
Above 1,372 (4,500)	65
Above 1,220 (4,000) to 1,372 (4,500)	70
Above 1,067 (3,500) to 1,220 (4,000)	75
Above 915 (3,000) to 1,067 (3,500)	100
Above 763 (2,500) to 915 (3,000)	140
Above 610 (2,000) to 763 (2,500)	200
Above 458 (1,500) to 610 (2,000)	350
Above 305 (1,000) to 458 (1,500)	600
Up to 305 (1,000)	1,000

Test Procedures:

Measurements were in accordance with the test methods section 3.5 of KDB 935210 D05 v01r04.

Adjust the internal gain control of the EUT to the maximum gain for which the equipment certification is being sought. Any EUT attenuation settings shall be set to their minimum value.

Input power levels (uplink and downlink) should be set to maximum input ratings while confirming that the device is not capable of operating in saturation (non-linear mode) at the rated input levels, including during the performance of the input/output power measurements.

3.5.2 Measuring the EUT mean input and output power

- a) Connect a signal generator to the input of the EUT.
- b) Configure to generate the AWGN (broadband) test signal.
- c) The frequency of the signal generator shall be set to the frequency f_0 as determined from 3.3.
- d) Connect a spectrum analyzer or power meter to the output of the EUT using appropriate attenuation as necessary.
- e) Set the signal generator output power to a level that produces an EUT output level that is just below the AGC threshold, but not more than 0.5 dB below.
- f) Measure and record the output power of the EUT; use 3.5.3 or 3.5.4 for power measurement.
- g) Remove the EUT from the measurement setup. Using the same signal generator settings, repeat the power measurement at the signal generator port, which was used as the input signal to the EUT, and record as the input power. EUT gain may be calculated as described in 3.5.5.
- h) Repeat steps f) and g) with input signal amplitude set to 3 dB above the AGC threshold level.
- i) Repeat steps e) to h) with the narrowband test signal.
- j) Repeat steps e) to i) for all frequency bands authorized for use by the EUT.

3.5.5 Calculating amplifier, repeater, or industrial booster gain

After the input and output power levels have been measured as described in the preceding subclauses, the gain of the EUT can be determined from:

$$\text{Gain (dB)} = \text{output power (dBm)} - \text{input power (dBm)}.$$

Report the gain for each authorized operating frequency band, and each test signal stimulus.

Note. If f_0 that determined from out-of-band test is smaller or greater than difference of test signal's center frequency and operation band block, test is performed at the lowest or the highest frequency that test signals can be passed.

Test Results:

Tabular data of Input / Output Power and Gain

Test Band	Link	Signal	f ₀ Frequency (MHz)	Input Power (dBm)	Output Power (dBm)	Gain (dB)
600 MHz	Downlink	LTE 5 MHz	620.24	-19.94	18.93	38.87
		LTE 10 MHz	622.00	-19.99	19.20	39.19
		LTE 20 MHz	627.00	-19.93	19.04	38.97
ESMR		CDMA	868.28	-20.10	19.22	39.32
		WCDMA	866.50	-20.10	19.35	39.45
		LTE 5 MHz	866.50	-19.98	19.26	39.24
Cellular		CDMA	871.76	-20.09	19.01	39.10
		WCDMA	871.76	-20.09	18.94	39.03
		LTE 5 MHz	871.76	-19.96	18.94	38.90
		LTE 10 MHz	874.00	-19.99	18.97	38.96
WCS	LTE 5 MHz	2 355.32	-20.36	22.97	43.33	
	LTE 10 MHz	2 355.00	-20.31	23.24	43.55	

Tabular data of Input / 3 dB above AGC threshold Output Power and Gain

Test Band	Link	Signal	f ₀ Frequency (MHz)	Input Power (dBm)	+3 dB Output Power (dBm)	Gain (dB)
600 MHz	Downlink	LTE 5 MHz	620.24	-17.15	18.84	35.99
		LTE 10 MHz	622.00	-16.88	19.21	36.09
		LTE 20 MHz	627.00	-16.92	18.98	35.90
ESMR		CDMA	868.28	-17.11	19.22	36.33
		WCDMA	866.50	-17.06	18.89	35.95
		LTE 5 MHz	866.50	-17.04	18.86	35.90
Cellular		CDMA	871.76	-16.94	19.16	36.10
		WCDMA	871.76	-17.03	19.00	36.03
		LTE 5 MHz	871.76	-17.04	18.97	36.01
		LTE 10 MHz	874.00	-16.99	19.11	36.10
WCS		LTE 5 MHz	2 355.32	-17.28	23.31	40.59
		LTE 10 MHz	2 355.00	-17.27	22.98	40.25



Tabular data of PAPR

Test Band	Link	Signal	f ₀ Frequency (MHz)	0.1 % PAPR (dB)
600 MHz	Downlink	LTE 5 MHz	620.24	7.91
		LTE 10 MHz	622.00	7.95
		LTE 20 MHz	627.00	8.24
ESMR		CDMA	868.28	7.79
		WCDMA	866.50	4.38
		LTE 5 MHz	866.50	8.40
Cellular		CDMA	871.76	7.80
		WCDMA	871.76	4.39
		LTE 5 MHz	871.76	8.45
		LTE 10 MHz	874.00	8.44
WCS		LTE 5 MHz	2 355.32	8.07
		LTE 10 MHz	2 355.00	8.01

Plot data of PAPR

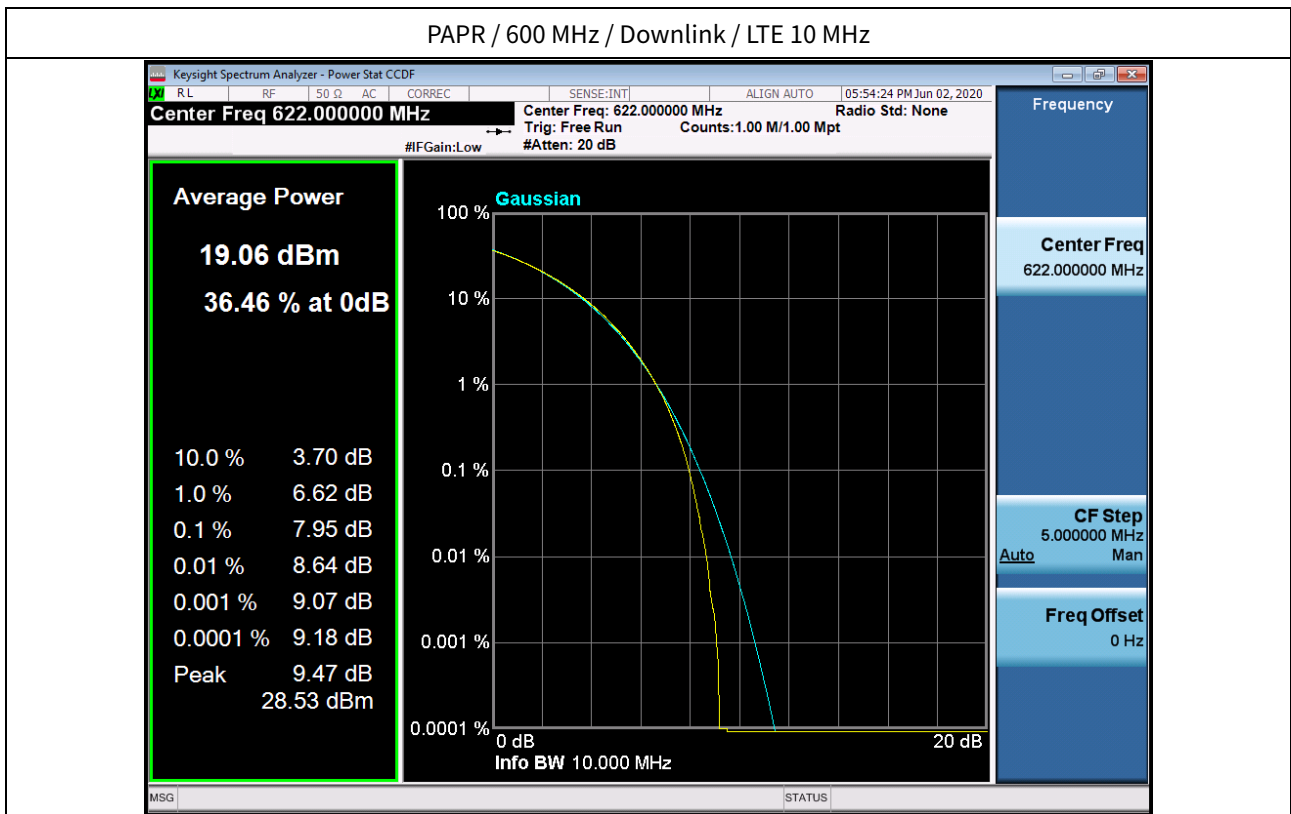
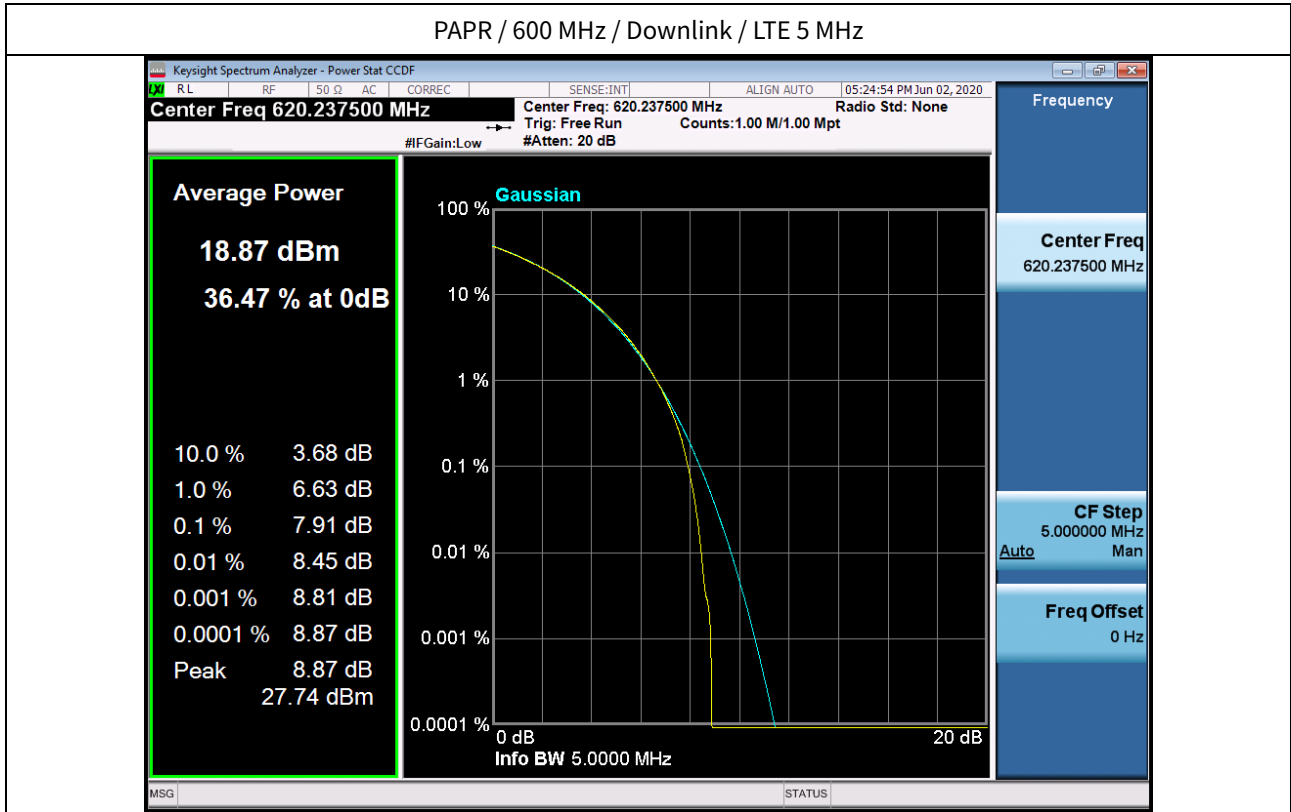

PAPR / 600 MHz / Downlink / LTE 20 MHz

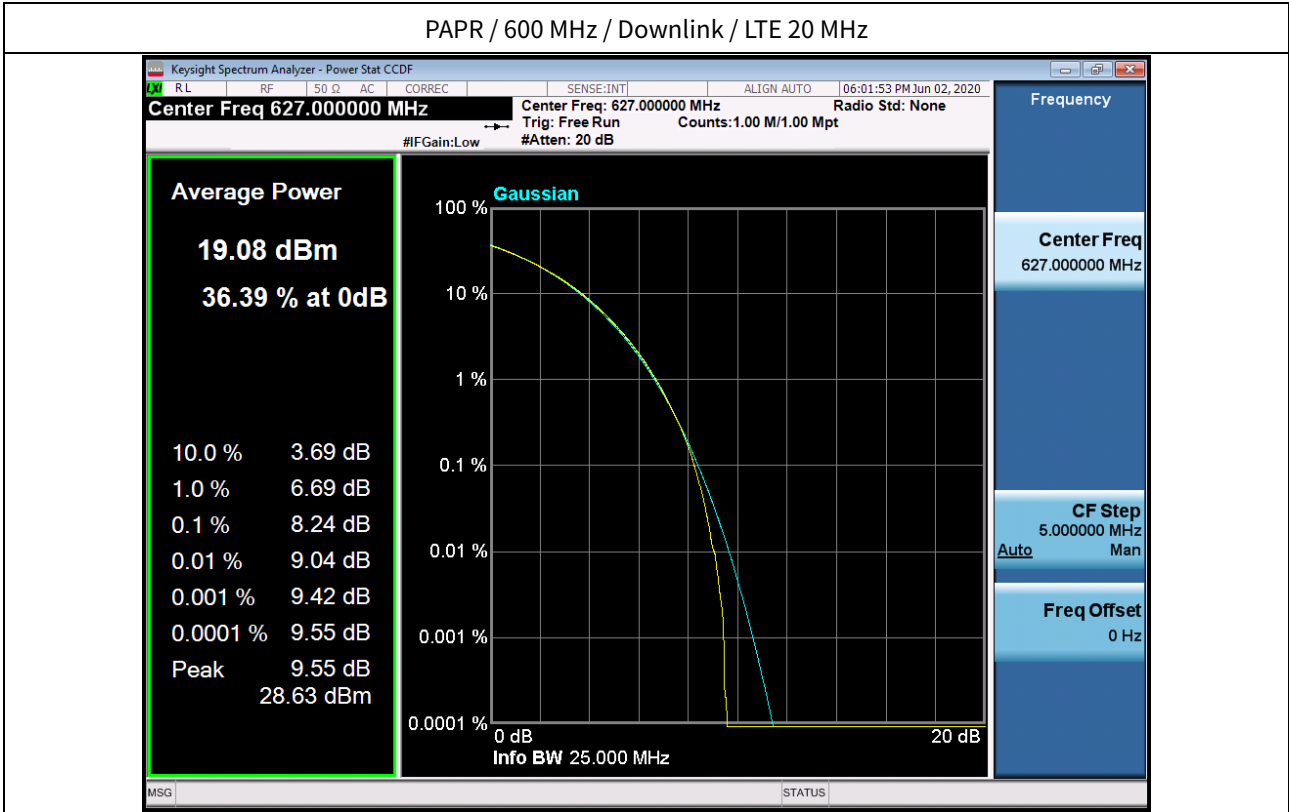

PAPR / ESMR / Downlink / CDMA

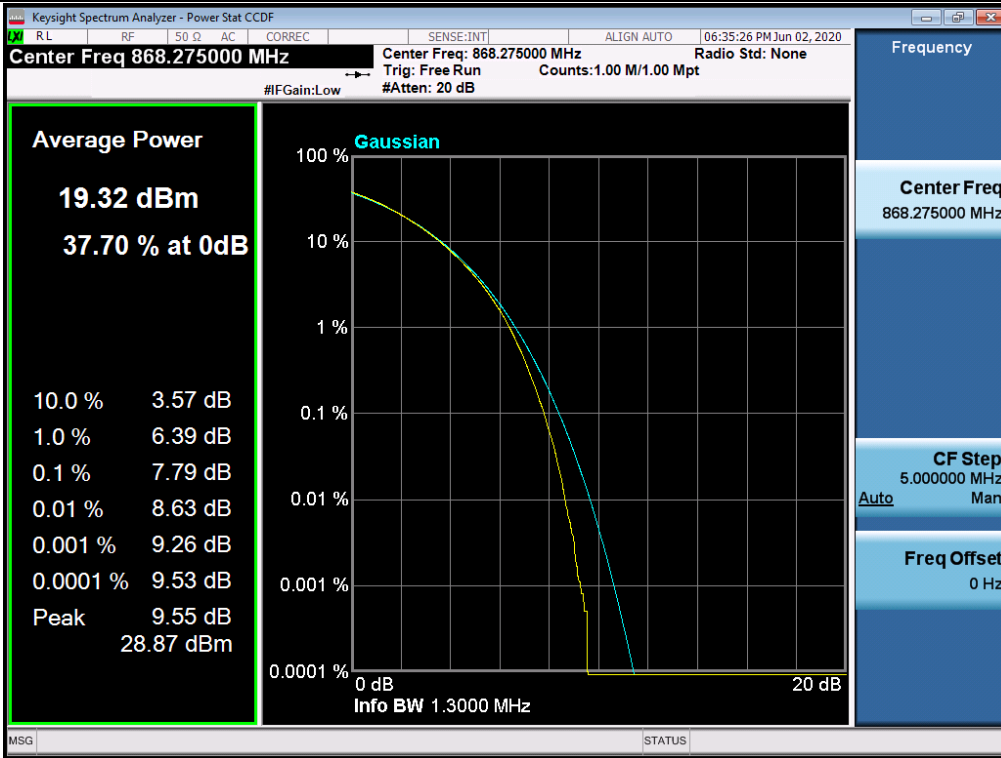

PAPR / ESMR / Downlink / WCDMA

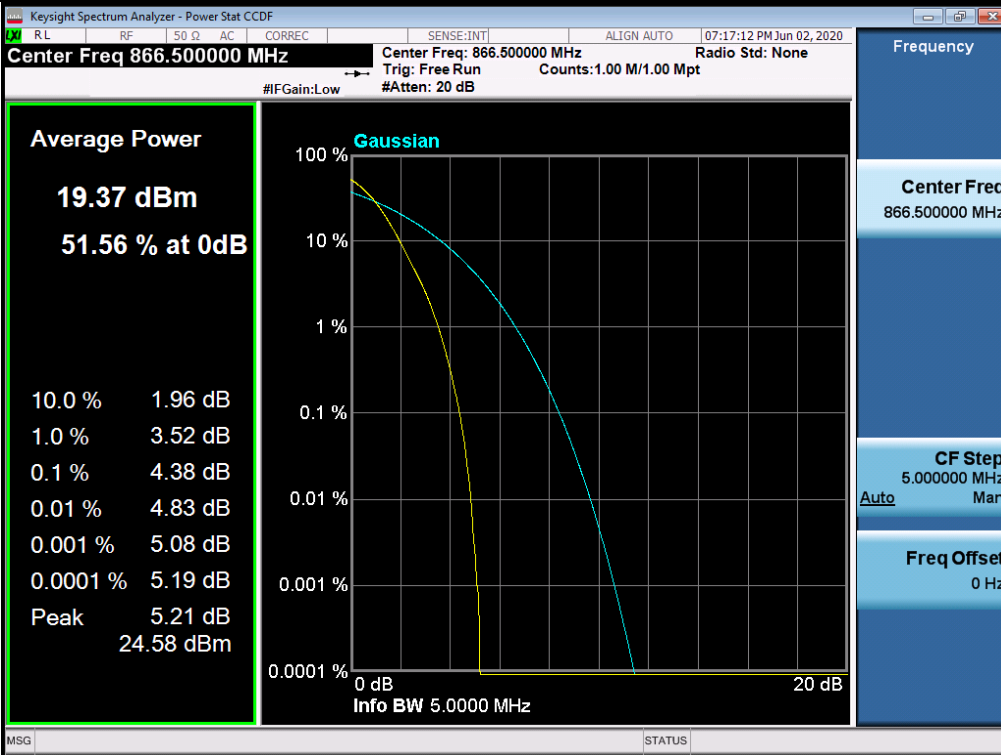

PAPR / ESMR / Downlink / LTE 5 MHz

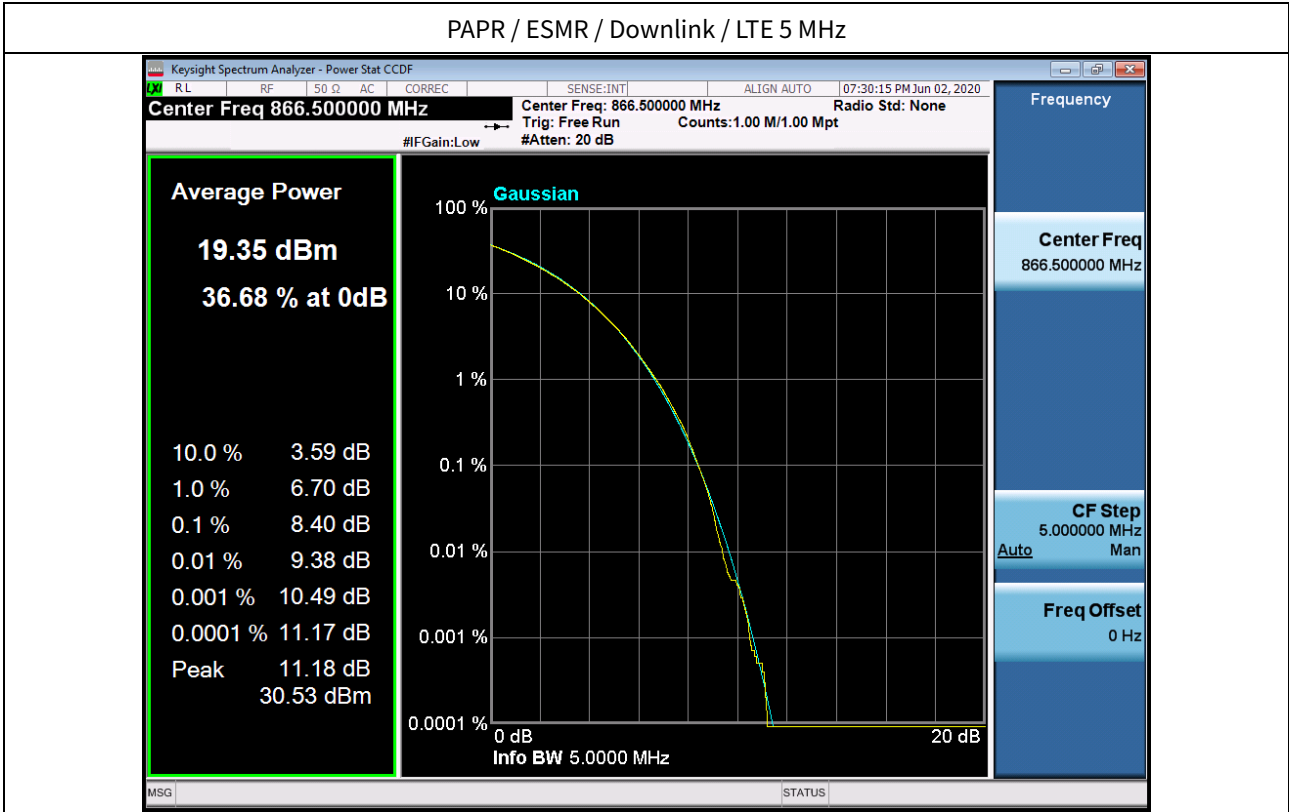

PAPR / Cellular / Downlink / CDMA

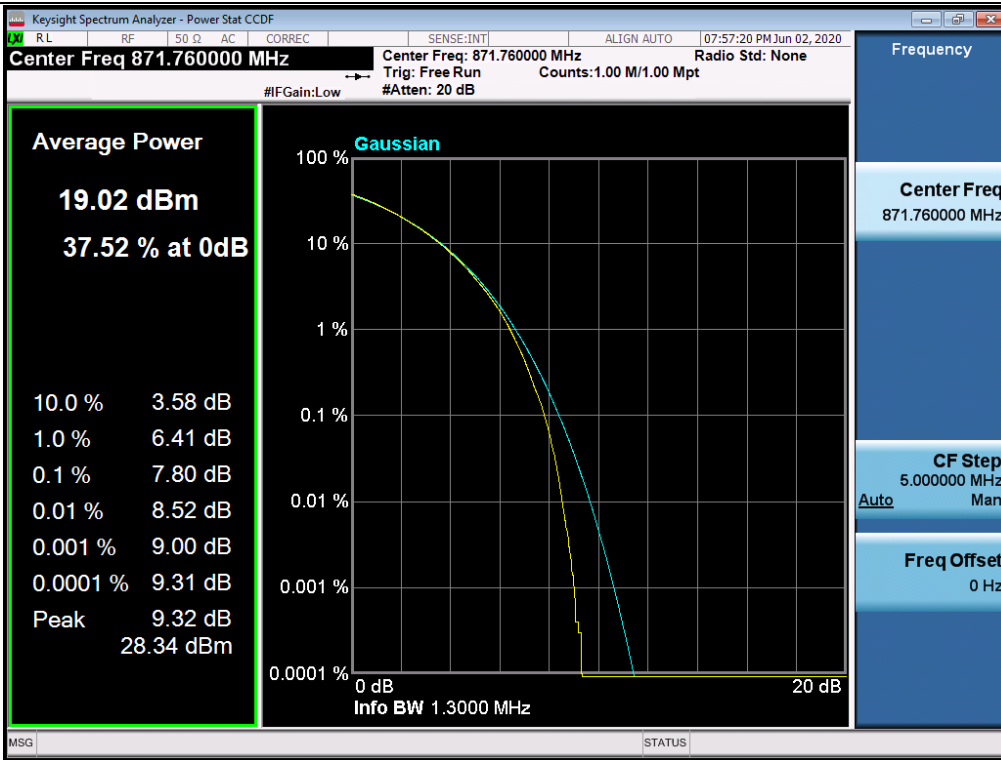

PAPR / Cellular / Downlink / WCDMA

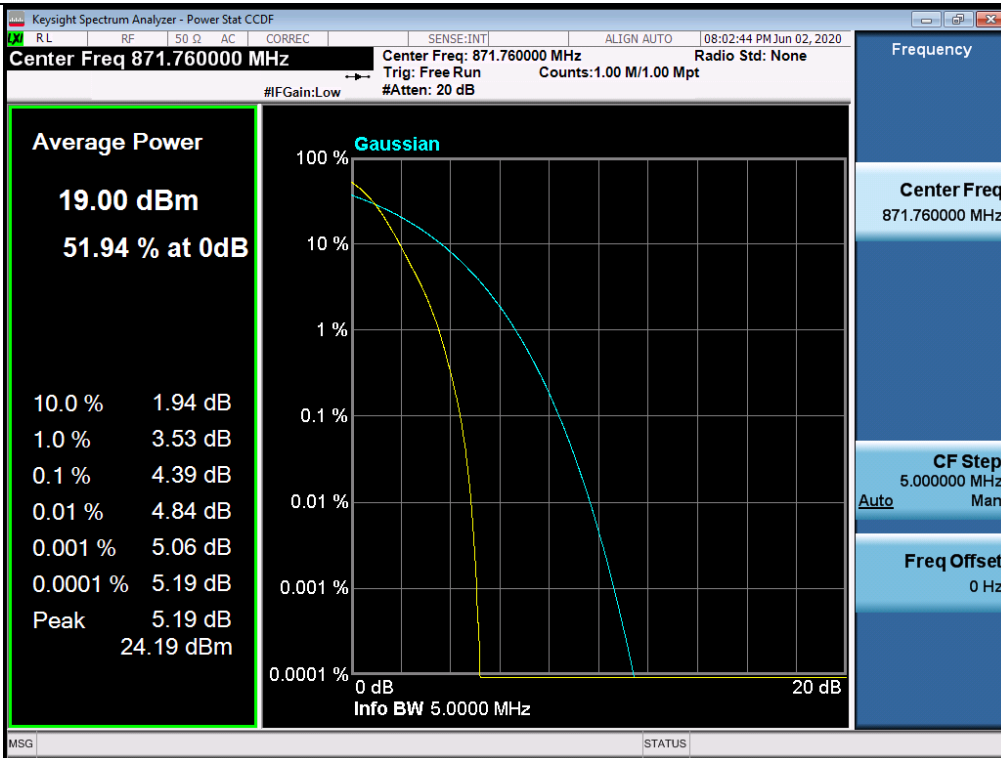

PAPR / Cellular / Downlink / LTE 5 MHz

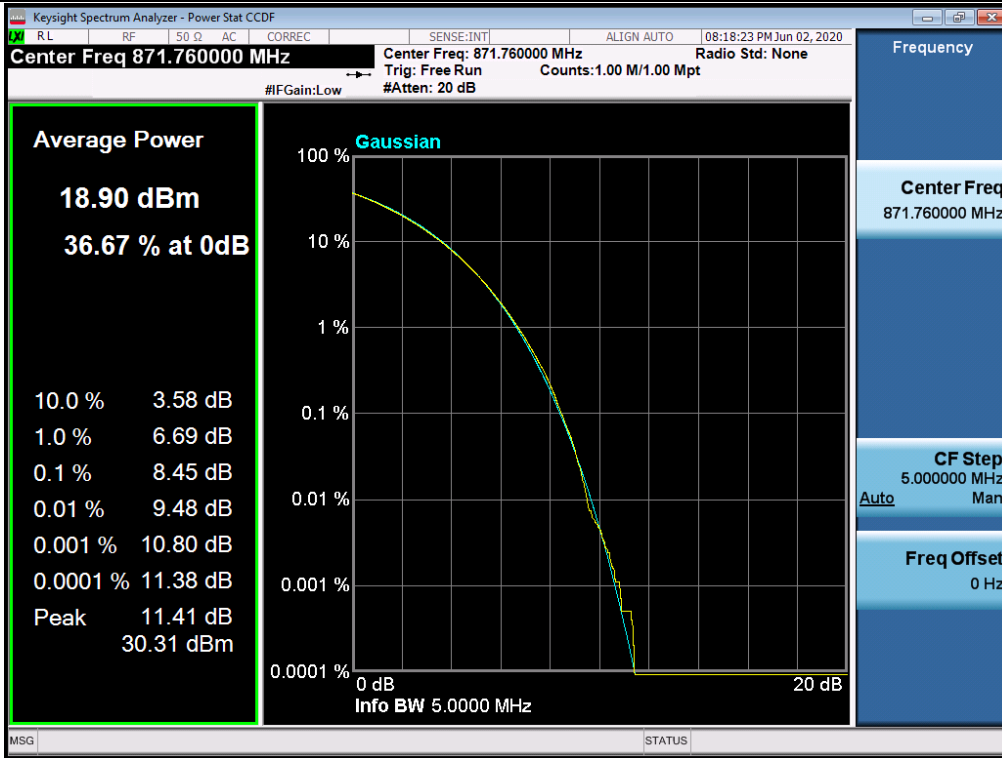

PAPR / Cellular / Downlink / LTE 10 MHz

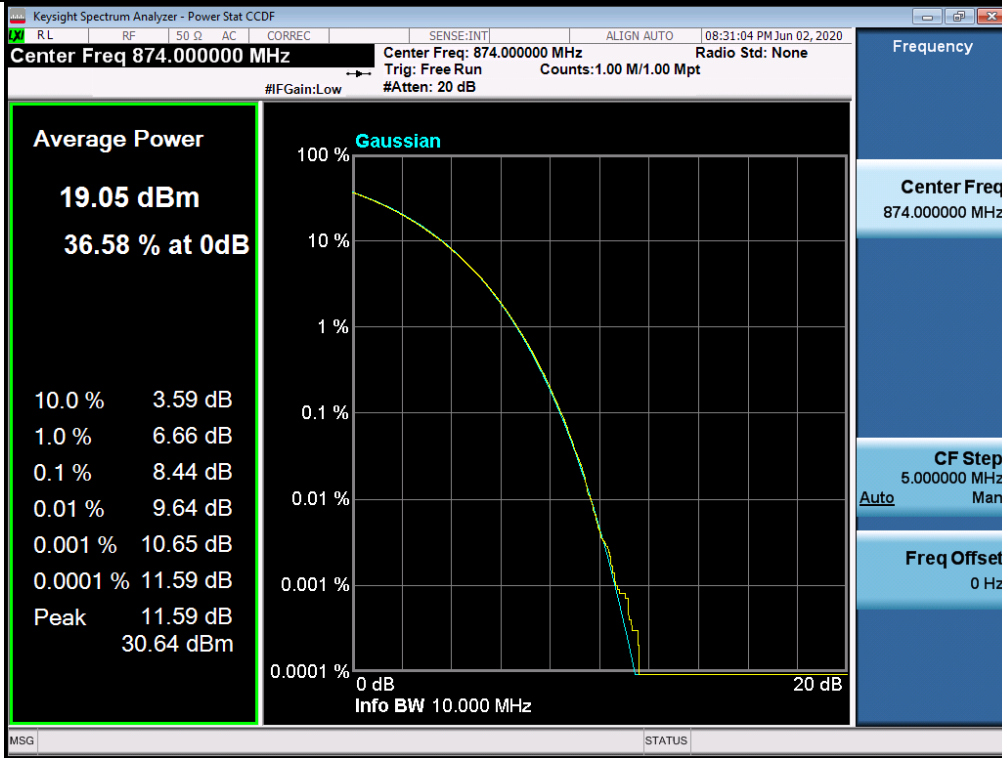

PAPR / WCS / Downlink / LTE 5 MHz

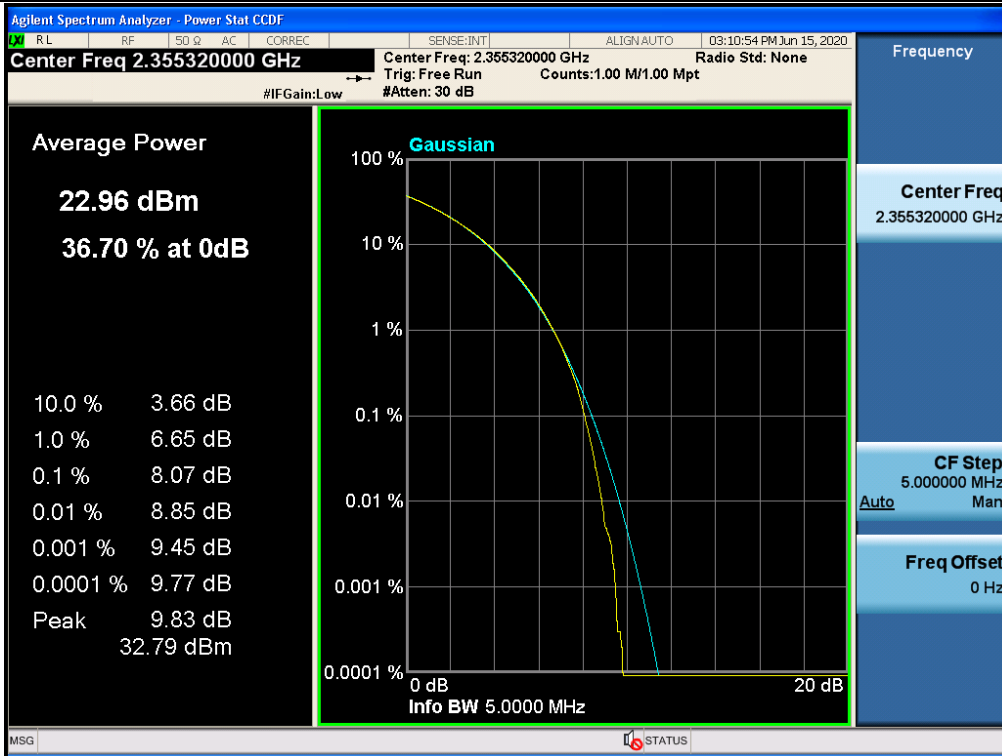

PAPR / WCS / Downlink / LTE 10 MHz

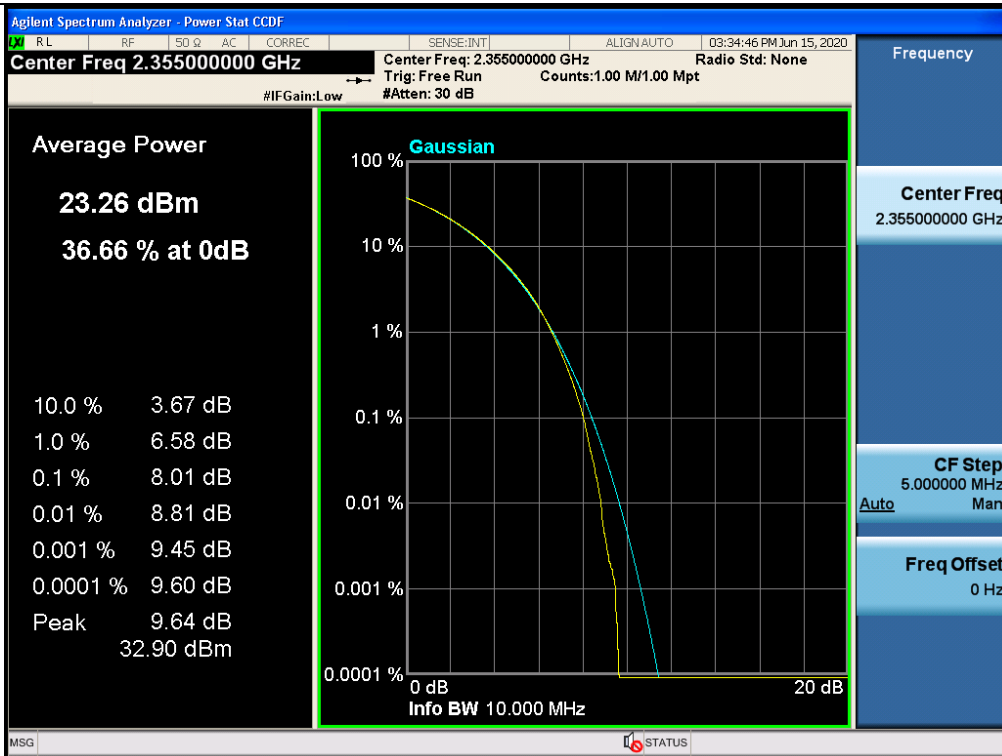

5.5. OUT-OF-BAND/OUT-OF-BLOCK EMISSIONS AND SPURIOUS EMISSIONS

Test Requirements:

§ 2.1051 Measurements required: Spurious emissions at antenna terminals.

The radio frequency voltage or powers generated within the equipment and appearing on a spurious frequency shall be checked at the equipment output terminals when properly loaded with a suitable artificial antenna. Curves or equivalent data shall show the magnitude of each harmonic and other spurious emission that can be detected when the equipment is operated under the conditions specified in § 2.1049 as appropriate. The magnitude of spurious emissions which are attenuated more than 20 dB below the permissible value need not be specified.

§ 22.917 Emission limitations for cellular equipment.

The rules in this section govern the spectral characteristics of emissions in the Cellular Radiotelephone Service.

(a) Out of band emissions. The power of any emission outside of the authorized operating frequency ranges must be attenuated below the transmitting power (P) by a factor of at least $43 + 10 \log(P)$ dB.

(b) Measurement procedure. Compliance with these rules is based on the use of measurement instrumentation employing a reference bandwidth as follows:

(1) In the spectrum below 1 GHz, instrumentation should employ a reference bandwidth of 100 kHz or greater.

In the 1 MHz bands immediately outside and adjacent to the frequency block, a resolution bandwidth of at least one percent of the emission bandwidth of the fundamental emission of the transmitter may be employed. A narrower resolution bandwidth is permitted in all cases to improve measurement accuracy, provided that the measured power is integrated over the full required reference bandwidth (i.e., 100 kHz or 1 percent of emission bandwidth, as specified). The emission bandwidth is defined as the width of the signal between two points, one below the carrier center frequency and one above the carrier center frequency, outside of which all emissions are attenuated at least 26 dB below the transmitter power.

(2) In the spectrum above 1 GHz, instrumentation should employ a reference bandwidth of 1 MHz.

(c) Alternative out of band emission limit. Licensees in this service may establish an alternative out of band emission limit to be used at specified band edge(s) in specified geographical areas, in lieu of that set forth in this section, pursuant to a private contractual arrangement of all affected licensees and applicants. In this event, each party to such contract shall maintain a copy of the contract in their station files and disclose it to prospective assignees or transferees and, upon request, to the FCC.

(d) Interference caused by out of band emissions. If any emission from a transmitter operating in this service results in interference to users of another radio service, the FCC may require a greater attenuation of that emission than specified in this section.

§ 27.53 Emission limits.

(a) For operations in the 2305-2320 MHz band and the 2345-2360 MHz band, the power of any emission outside a licensee's frequency band(s) of operation shall be attenuated below the transmitter power P (with averaging performed only during periods of transmission) within the licensed band(s) of operation, in watts, by the following amounts:

- (1) For base and fixed stations' operations in the 2305-2320 MHz band and the 2345-2360 MHz band:
 - (i) By a factor of not less than $43 + 10 \log (P)$ dB on all frequencies between 2305 and 2320 MHz and on all frequencies between 2345 and 2360 MHz that are outside the licensed band(s) of operation, and not less than $75 + 10 \log (P)$ dB on all frequencies between 2320 and 2345 MHz;
 - (ii) By a factor of not less than $43 + 10 \log (P)$ dB on all frequencies between 2300 and 2305 MHz, $70 + 10 \log (P)$ dB on all frequencies between 2287.5 and 2300 MHz, $72 + 10 \log (P)$ dB on all frequencies between 2285 and 2287.5 MHz, and $75 + 10 \log (P)$ dB below 2285 MHz;
 - (iii) By a factor of not less than $43 + 10 \log (P)$ dB on all frequencies between 2360 and 2362.5 MHz, $55 + 10 \log (P)$ dB on all frequencies between 2362.5 and 2365 MHz, $70 + 10 \log (P)$ dB on all frequencies between 2365 and 2367.5 MHz, $72 + 10 \log (P)$ dB on all frequencies between 2367.5 and 2370 MHz, and $75 + 10 \log (P)$ dB above 2370 MHz.

(5) *Measurement procedure.* Compliance with these rules is based on the use of measurement instrumentation employing a resolution bandwidth of 1 MHz or greater. However, in the 1 MHz bands immediately outside and adjacent to the channel blocks at 2305, 2310, 2315, 2320, 2345, 2350, 2355, and 2360 MHz, a resolution bandwidth of at least 1 percent of the emission bandwidth of the fundamental emission of the transmitter may be employed. A narrower resolution bandwidth is permitted in all cases to improve measurement accuracy provided the measured power is integrated over the full required measurement bandwidth (*i.e.*, 1 MHz). The emission bandwidth is defined as the width of the signal between two points, one below the carrier center frequency and one above the carrier center frequency, outside of which all emissions are attenuated at least 26 dB below the transmitter power.

(g) For operations in the 600 MHz band and the 698-746 MHz band, the power of any emission outside a licensee's frequency band(s) of operation shall be attenuated below the transmitter power (P) within the licensed band(s) of operation, measured in watts, by at least $43 + 10 \log (P)$ dB. Compliance with this provision is based on the use of measurement instrumentation employing a resolution bandwidth of 100 kilohertz or greater. However, in the 100 kilohertz bands immediately outside and adjacent to a licensee's frequency block, a resolution bandwidth of at least 30 kHz may be employed.

Test Procedures:

Measurements were in accordance with the test methods section 3.6 of KDB 935210 D05 v01r04.

Spurious emissions shall be measured using a single test signal sequentially tuned to the low, middle, and high channels or frequencies within each authorized frequency band of operation.

Out-of-band/out-of-block emissions (including intermodulation products) shall be measured under each of the following two stimulus conditions:

- a) two adjacent test signals sequentially tuned to the lower and upper frequency band/block edges;
- b) a single test signal, sequentially tuned to the lowest and highest frequencies or channels within the frequency band/block under examination.

NOTE—Single-channel boosters that cannot accommodate two simultaneous signals within the passband may be excluded from the test stipulated in step a).

3.6.2 Out-of-band/out-of-block emissions conducted measurements

- a) Connect a signal generator to the input of the EUT.
If the signal generator is not capable of generating two modulated carriers simultaneously, then two discrete signal generators can be connected with an appropriate combining network to support this two-signal test.
- b) Set the signal generator to produce two AWGN signals as previously described.
- c) Set the center frequencies such that the AWGN signals occupy adjacent channels, as defined by industry standards such as 3GPP or 3GPP2, at the upper edge of the frequency band or block under test.
- d) Set the composite power levels such that the input signal is just below the AGC threshold, but not more than 0.5 dB below. The composite power can be measured using the procedures provided in KDB Publication 971168, but it will be necessary to expand the power integration bandwidth so as to include both of the transmit channels.
- e) Connect a spectrum analyzer to the output of the EUT using appropriate attenuation as necessary.
- f) Set the RBW = reference bandwidth in the applicable rule section for the supported frequency band.
- g) Set the VBW = $3 \times$ RBW.
- h) Set the detector to power averaging (rms) detector.
- i) Set the Sweep time = auto-couple.
- j) Set the spectrum analyzer start frequency to the upper block edge frequency, and the stop frequency to the upper block edge frequency plus 300 kHz or 3 MHz, for frequencies below and above 1 GHz, respectively.
- k) Trace average at least 100 traces in power averaging (rms) mode.
- l) Use the marker function to find the maximum power level.
- m) Capture the spectrum analyzer trace of the power level for inclusion in the test report.
- n) Repeat steps k) to m) with the composite input power level set to 3 dB above the AGC threshold.
- o) Reset the frequencies of the input signals to the lower edge of the frequency block or band under test.
- p) Reset the spectrum analyzer start frequency to the lower block edge frequency minus 300 kHz or 3 MHz, for frequencies below and above 1 GHz, respectively, and the stop frequency to the lower band or block edge frequency.
- q) Repeat steps k) to n).
- r) Repeat steps a) to q) with the signal generator configured for a single test signal tuned as close as possible to the block edges.
- s) Repeat steps a) to r) with the narrowband test signal.
- t) Repeat steps a) to s) for all authorized frequency bands or blocks used by the EUT.

3.6.3 Spurious emissions conducted measurements

- a) Connect a signal generator to the input of the EUT.
- b) Set the signal generator to produce the broadband test signal as previously described.

- c) Set the center frequency of the test signal to the lowest available channel within the frequency band or block.
- d) Set the EUT input power to a level that is just below the AGC threshold, but not more than 0.5 dB below.
- e) Connect a spectrum analyzer to the output of the EUT using appropriate attenuation as necessary.
- f) Set the RBW = reference bandwidth in the applicable rule section for the supported frequency band of operation.
- g) Set the VBW $\geq 3 \times$ RBW.
- h) Set the Sweep time = auto-couple.
- i) Set the spectrum analyzer start frequency to the lowest RF signal generated in the equipment, without going below 9 kHz, and the stop frequency to the lower band/block edge frequency minus 1 MHz.
The number of measurement points in each sweep must be $\geq (2 \times \text{span}/\text{RBW})$, which may require that the measurement range defined by the start and stop frequencies be subdivided, depending on the available number of measurement points provided by the spectrum analyzer.
- j) Select the power averaging (rms) detector function.
- k) Trace average at least 10 traces in power averaging (rms) mode.
- l) Use the peak marker function to identify the highest amplitude level over each measured frequency range. Record the frequency and amplitude and capture a plot for inclusion in the test report.
- m) Reset the spectrum analyzer start frequency to the upper band/block edge frequency plus 1 MHz, and the spectrum analyzer stop frequency to 10 times the highest frequency of the fundamental emission. The number of measurement points in each sweep must be $\geq (2 \times \text{span}/\text{RBW})$, which may require that the measurement range defined by the start and stop frequencies be subdivided, depending on the available number of measurement points provided by the spectrum analyzer.
- n) Trace average at least 10 traces in power averaging (rms) mode.
- o) Use the peak marker function to identify the highest amplitude level over each of the measured frequency ranges. Record the frequency and amplitude and capture a plot for inclusion in the test report; also provide tabular data, if required.
- p) Repeat steps i) to o) with the input test signals firstly tuned to a middle band/block frequency/channel, and then tuned to a high band/block frequency/channel.
- q) Repeat steps b) to p) with the narrowband test signal.
- r) Repeat steps b) to q) for all authorized frequency bands/blocks used by the EUT.

Note1. In 9 kHz-150 kHz and 150 kHz-30 MHz bands, RBW was reduced to 1 kHz and 10 kHz and correction factor was applied according to section 5.7.2 of ANSI C63.26-2015

Band	9 ~ 150 kHz Correction	150 kHz ~ 30 MHz Correction
Below 1 GHz (Ref.RBW: 100 kHz)	20 dB	10 dB
Above 1 GHz (Ref.RBW: 1 MHz)	30 dB	20 dB

Note2. Among the data of simultaneous and single band emission conditions, the single emission condition is the worst.

Test Results: Plot data of Out-of-band/out-of-block emissions

Out-of-band (two adjacent test signals) / 600 MHz / Downlink / LTE 5 MHz / Lower

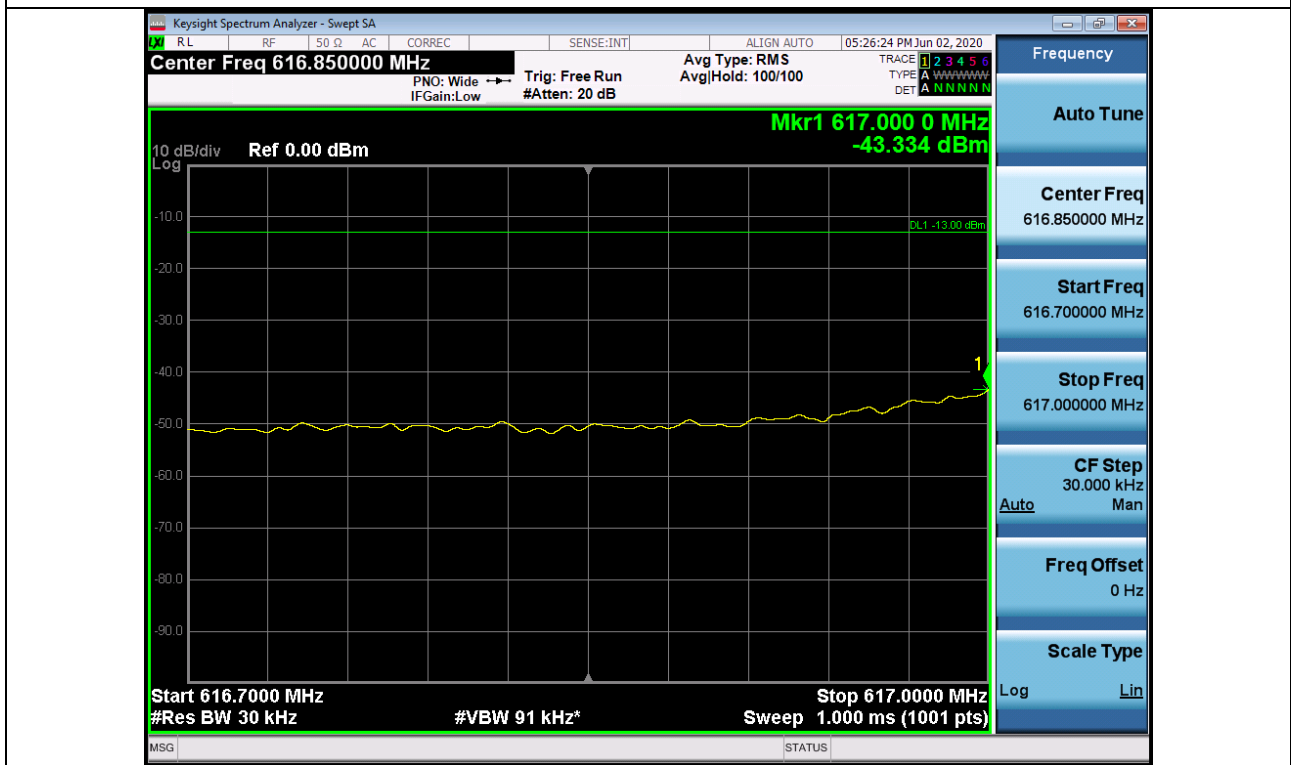

Out-of-band (two adjacent test signals) / 600 MHz / Downlink / LTE 5 MHz / Upper



+3 dB above Out-of-band (two adjacent test signals) / 600 MHz / Downlink / LTE 5 MHz / Lower

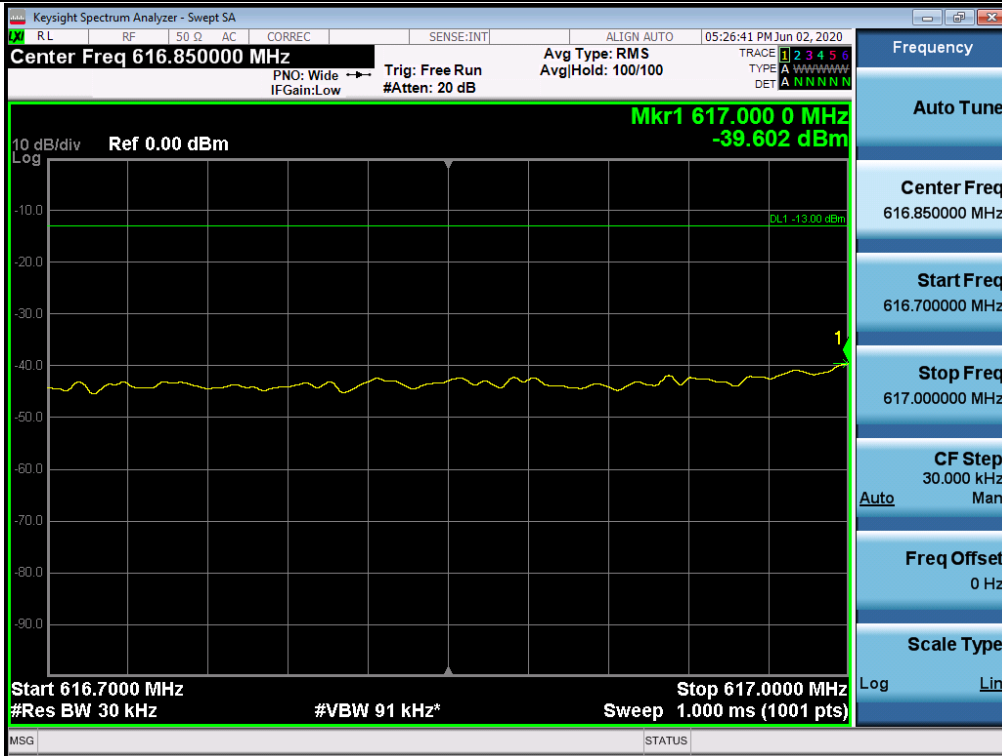

+3 dB above Out-of-band (two adjacent test signals) / 600 MHz / Downlink / LTE 5 MHz / Upper

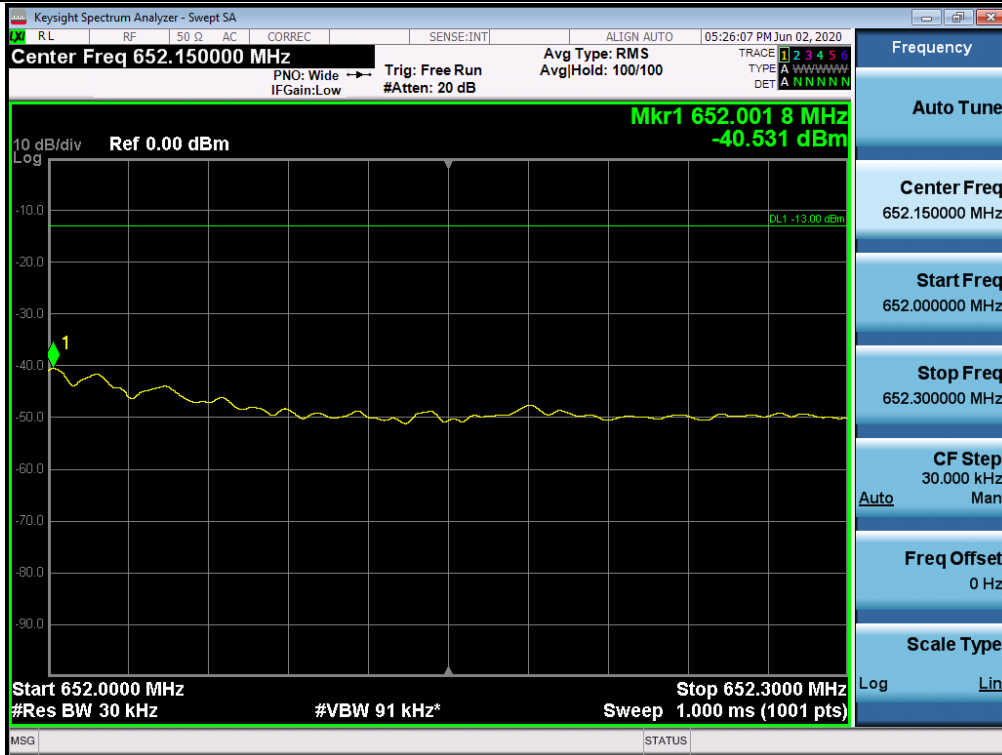

Out-of-band (two adjacent test signals) / 600 MHz / Downlink / LTE 10 MHz / Lower

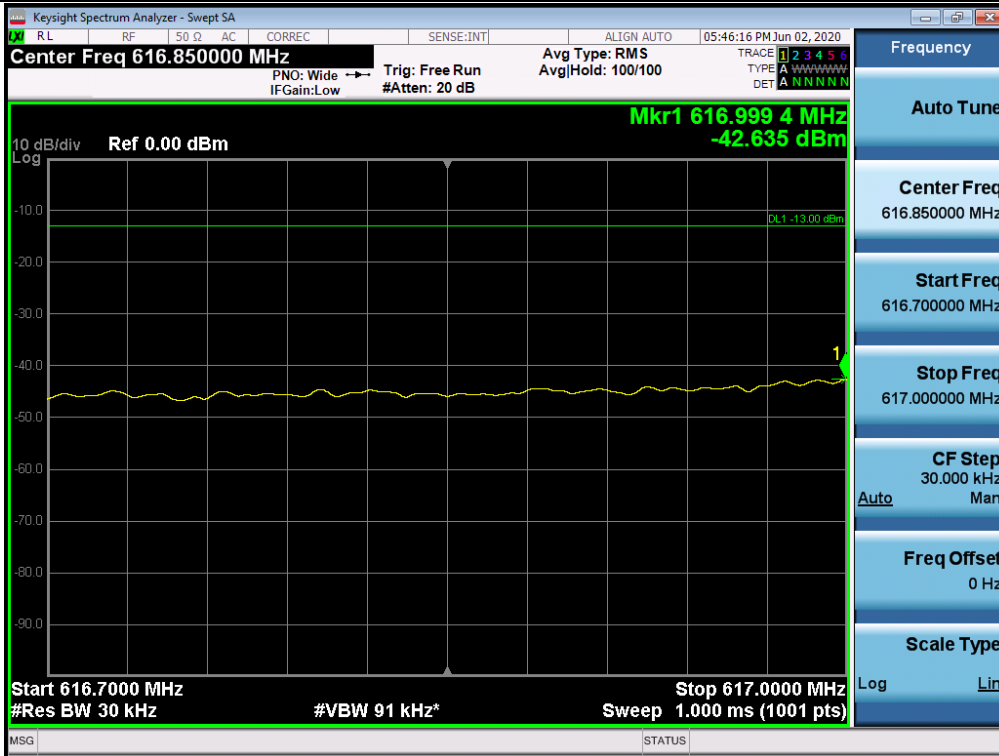

Out-of-band (two adjacent test signals) / 600 MHz / Downlink / LTE 10 MHz / Upper



+3 dB above Out-of-band (two adjacent test signals) / 600 MHz / Downlink / LTE 10 MHz / Lower

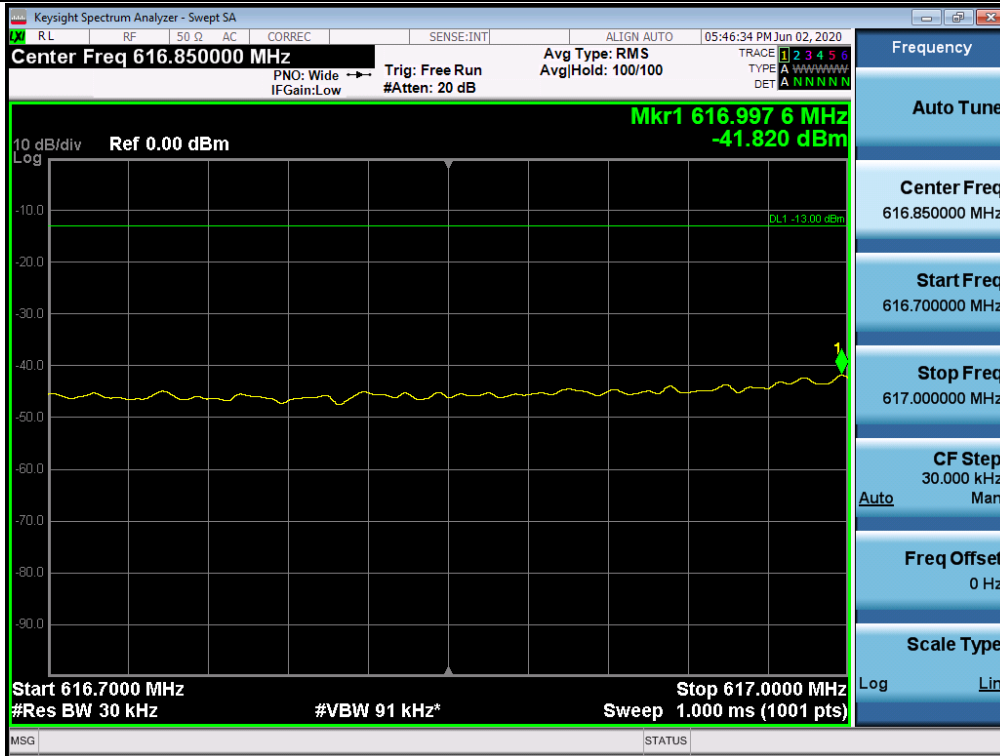

+3 dB above Out-of-band (two adjacent test signals) / 600 MHz / Downlink / LTE 10 MHz / Upper

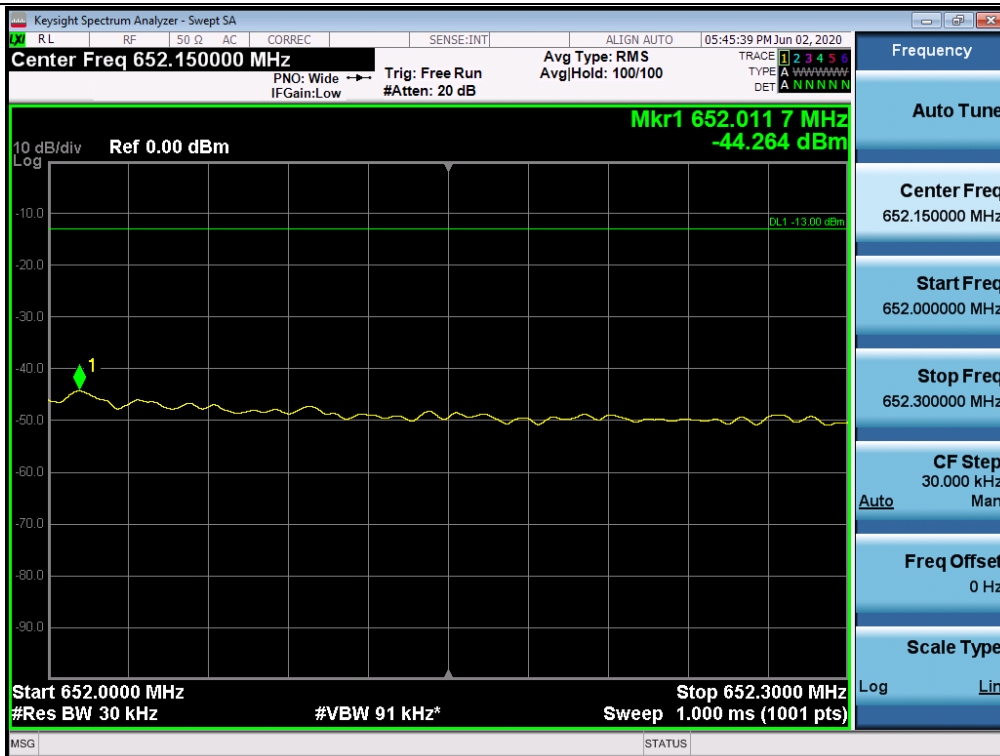

Out-of-band (two adjacent test signals) / ESMR / Downlink / CDMA / Lower

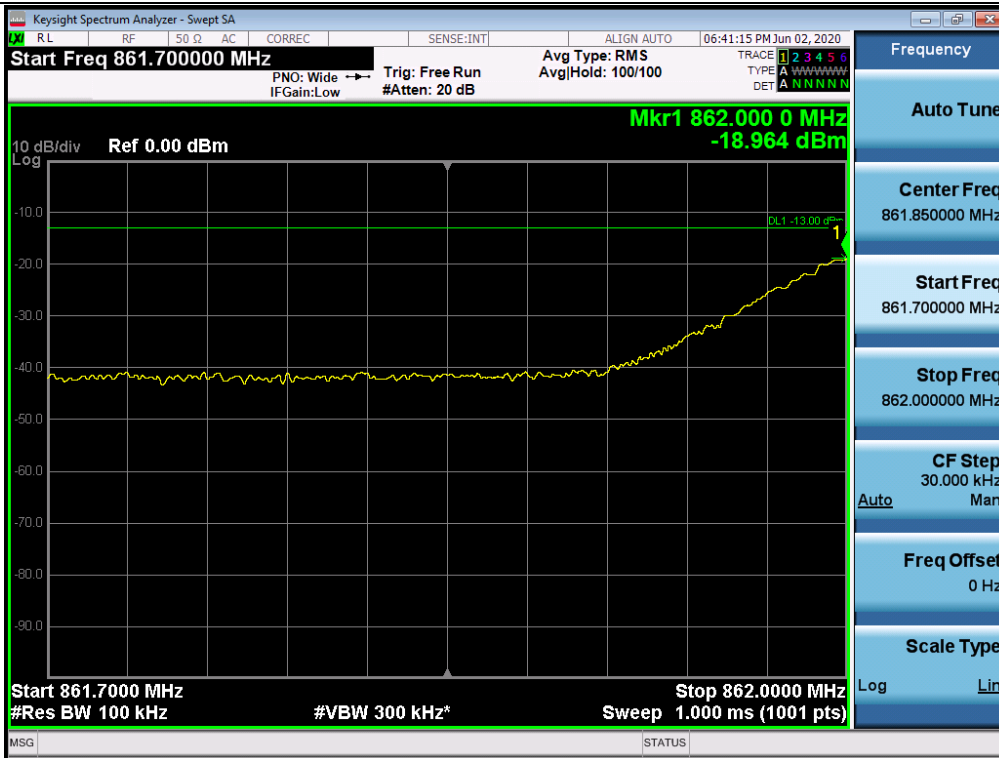

Out-of-band (two adjacent test signals) / ESMR / Downlink / CDMA / Upper



+3 dB above Out-of-band (two adjacent test signals) / ESMR / Downlink / CDMA / Lower

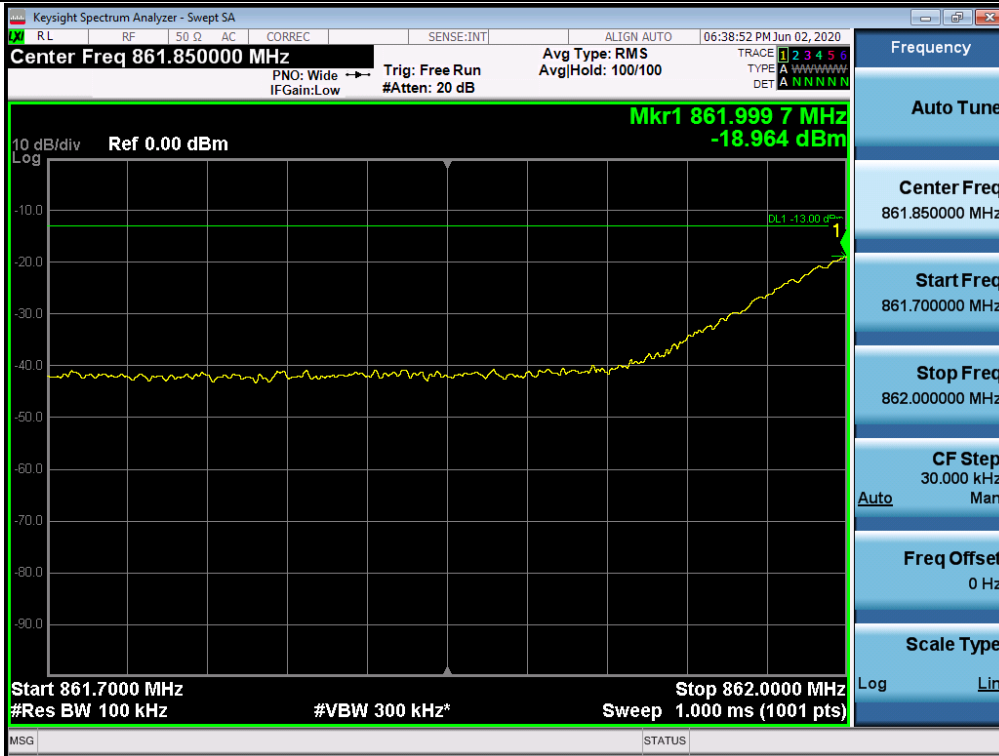

+3 dB above Out-of-band (two adjacent test signals) / ESMR / Downlink / CDMA / Upper



Out-of-band (two adjacent test signals) / Cellular / Downlink / CDMA / Lower

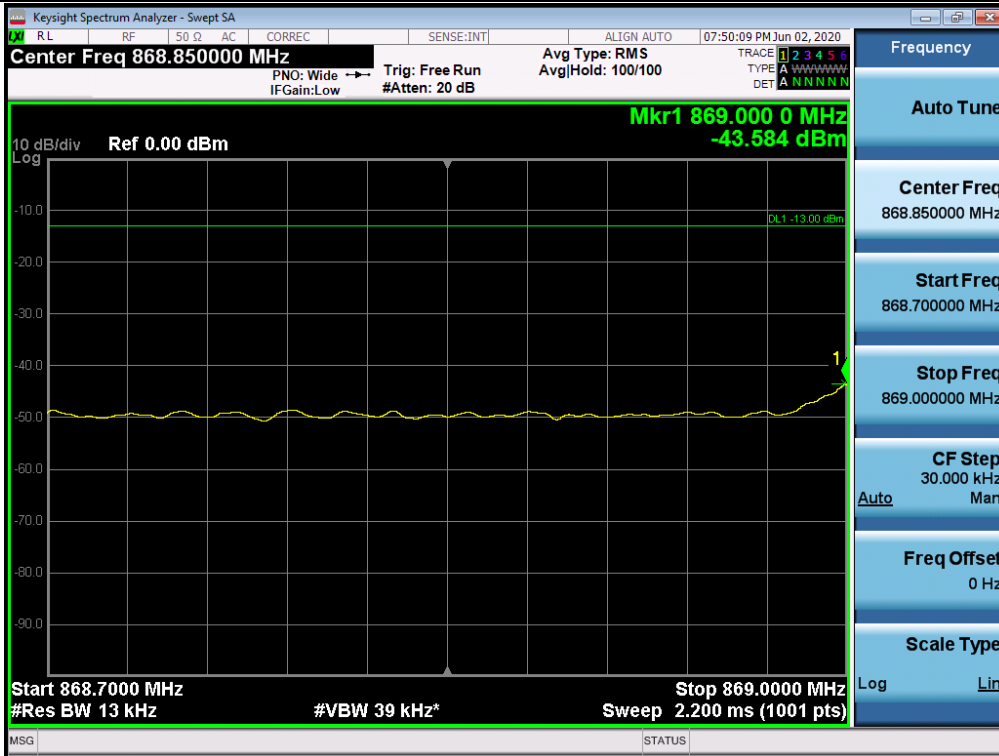

Out-of-band (two adjacent test signals) / Cellular / Downlink / CDMA / Upper



+3 dB above Out-of-band (two adjacent test signals) / Cellular / Downlink / CDMA / Lower

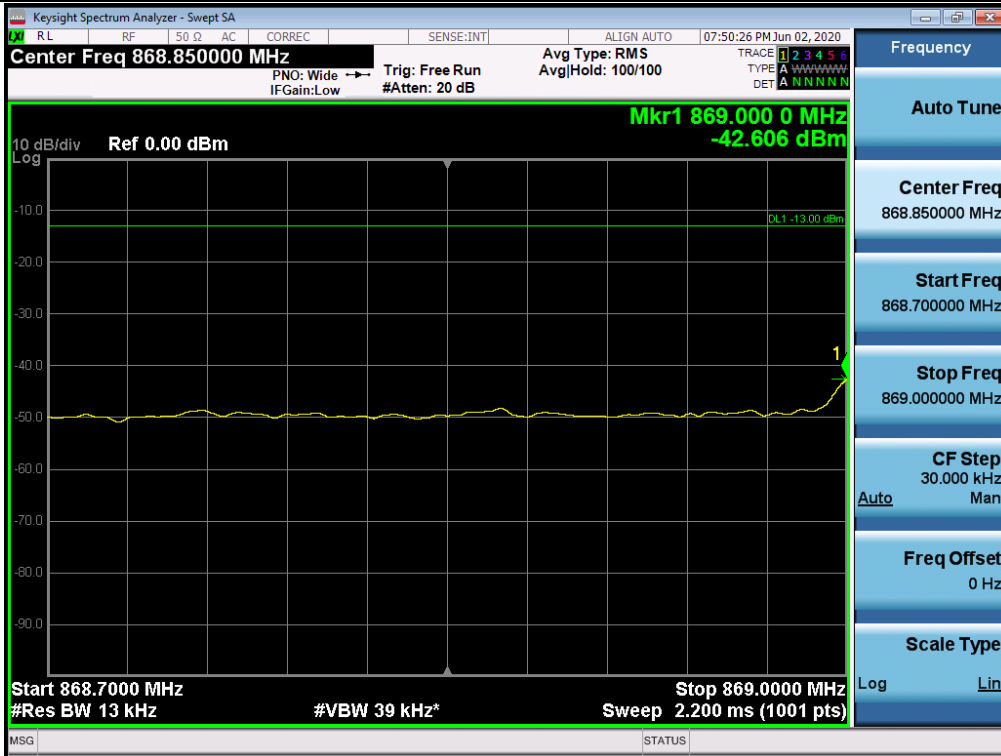

+3 dB above Out-of-band (two adjacent test signals) / Cellular / Downlink / CDMA / Upper

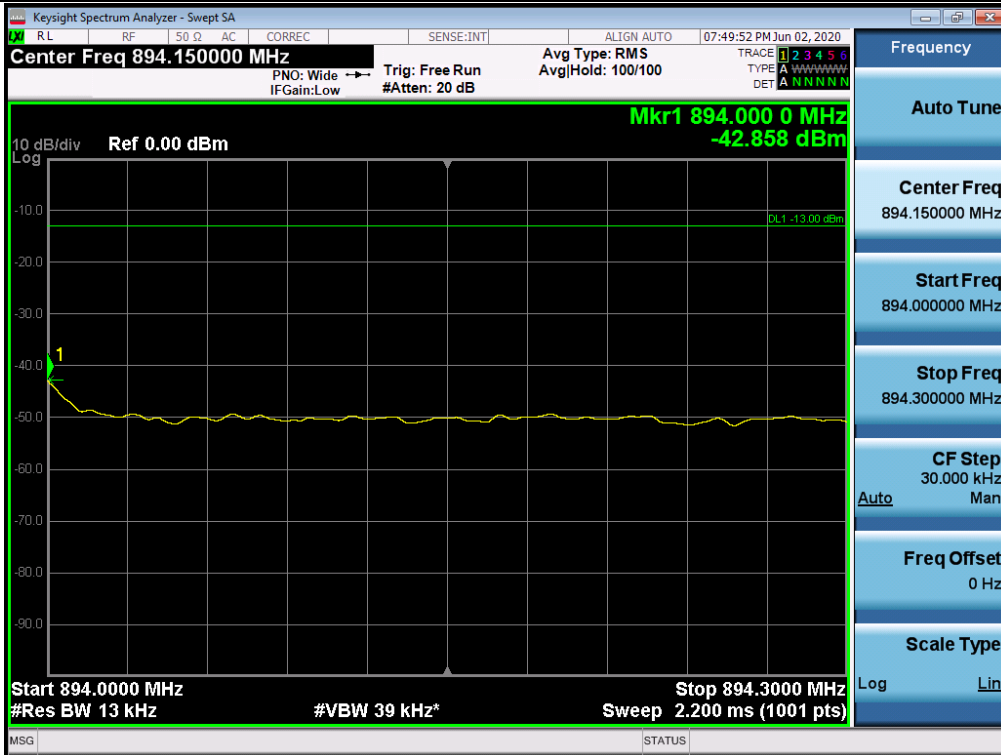

Out-of-band (two adjacent test signals) / Cellular / Downlink / WCDMA / Lower

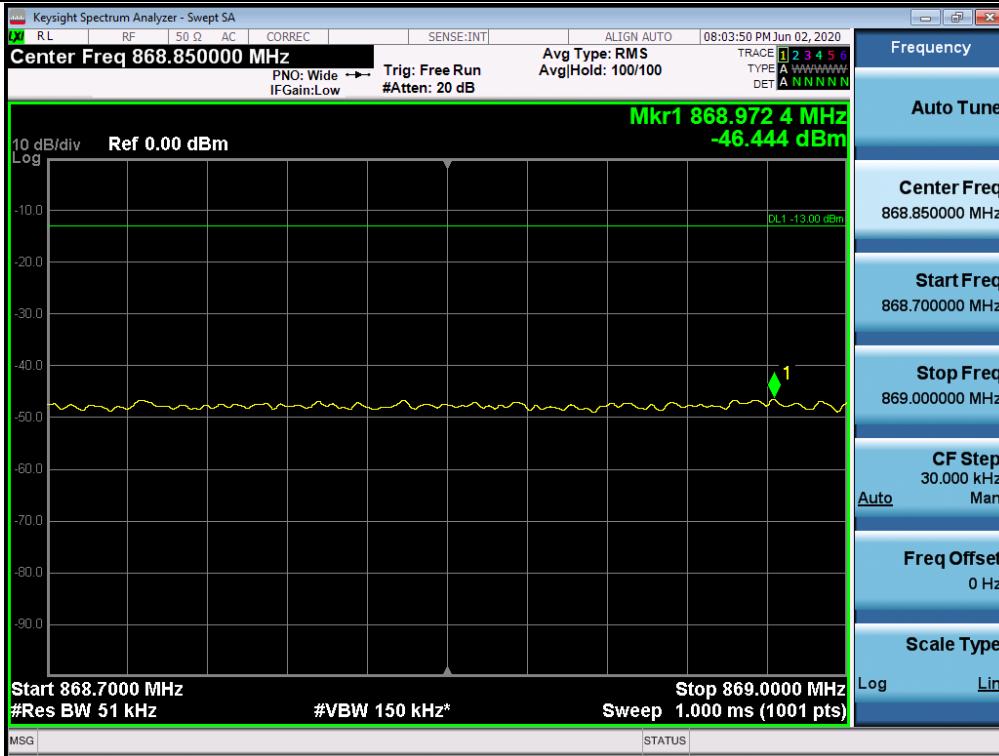

Out-of-band (two adjacent test signals) / Cellular / Downlink / WCDMA / Upper

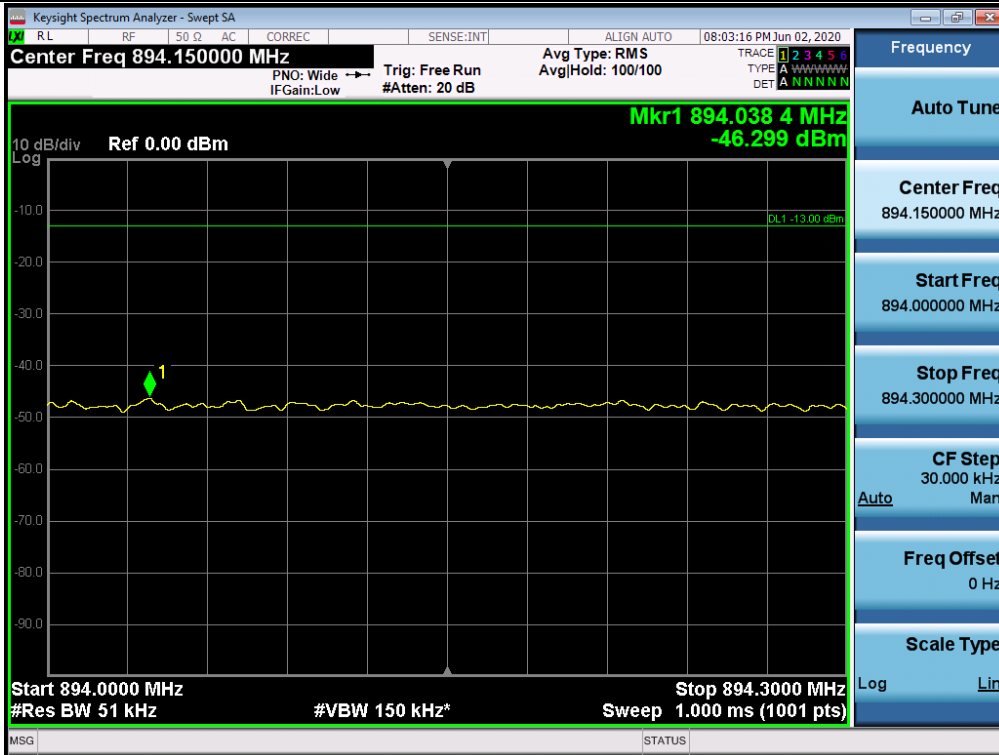

+3 dB above Out-of-band (two adjacent test signals) / Cellular / Downlink / WCDMA / Lower

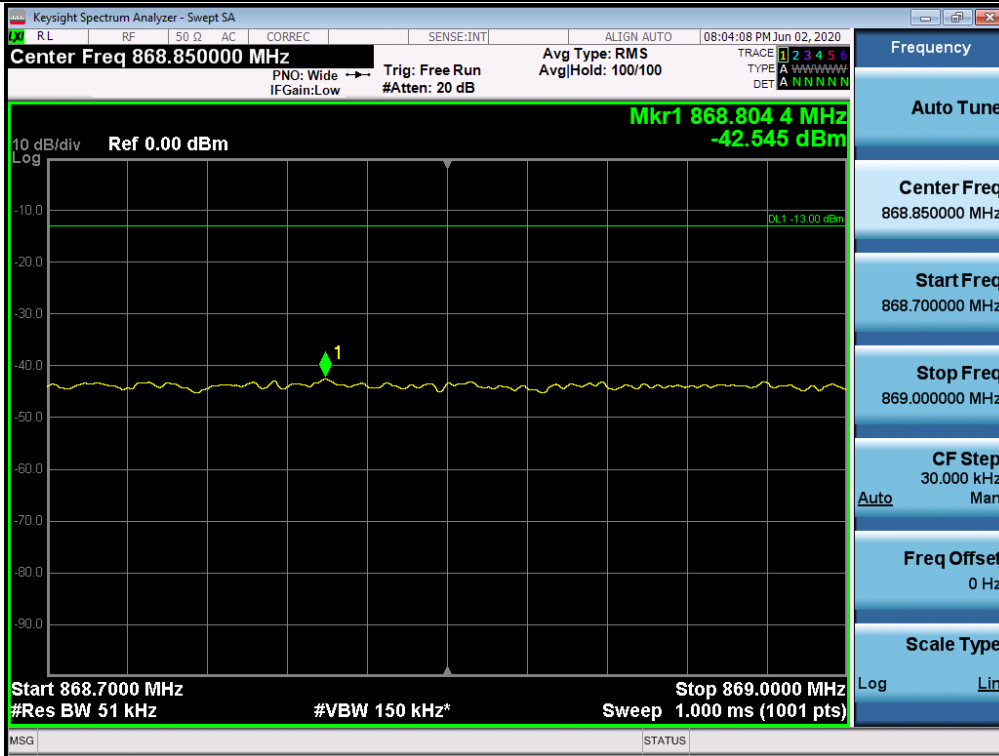

+3 dB above Out-of-band (two adjacent test signals) / Cellular / Downlink / WCDMA / Upper

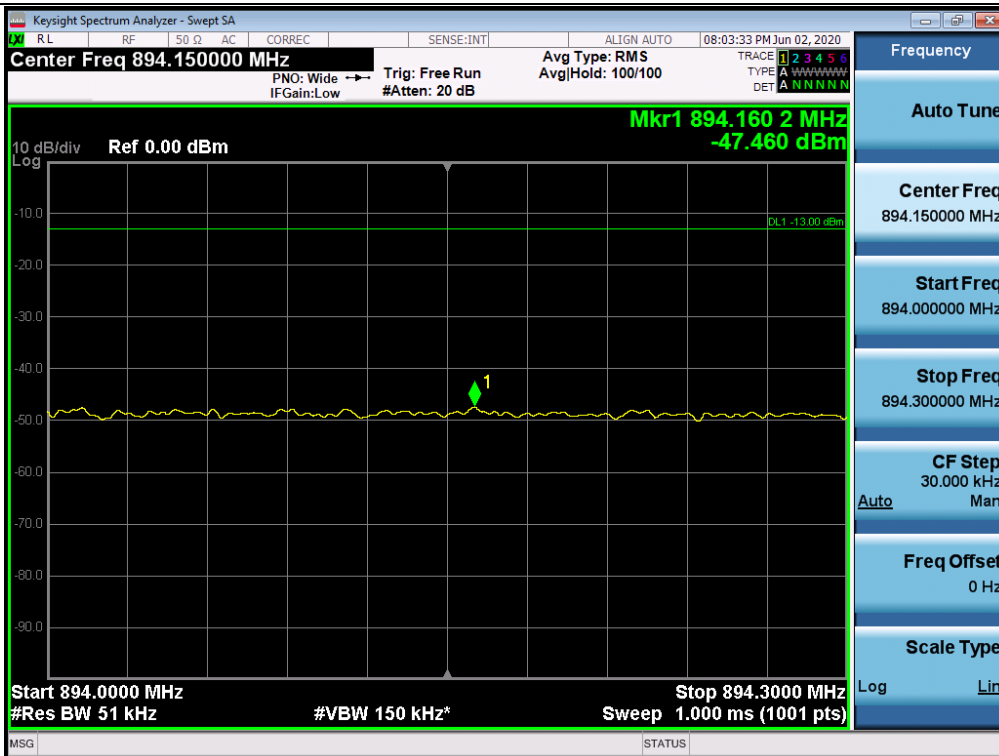

Out-of-band (two adjacent test signals) / Cellular / Downlink / LTE 5 MHz / Lower

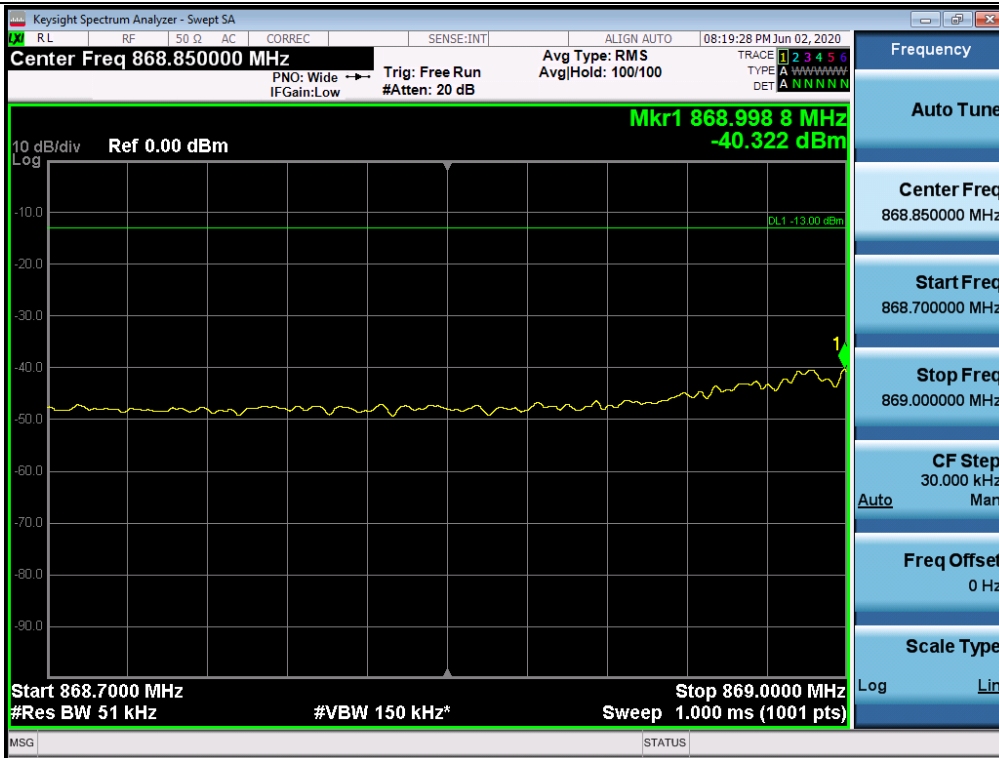

Out-of-band (two adjacent test signals) / Cellular / Downlink / LTE 5 MHz / Upper

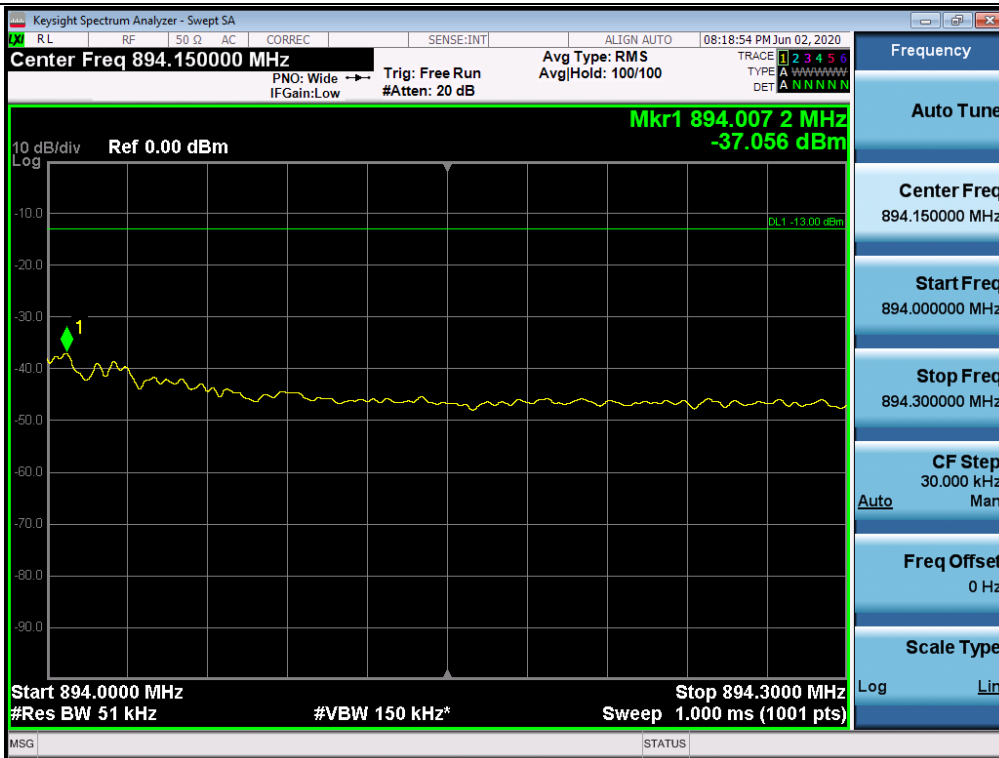

+3 dB above Out-of-band (two adjacent test signals) / Cellular / Downlink / LTE 5 MHz / Lower

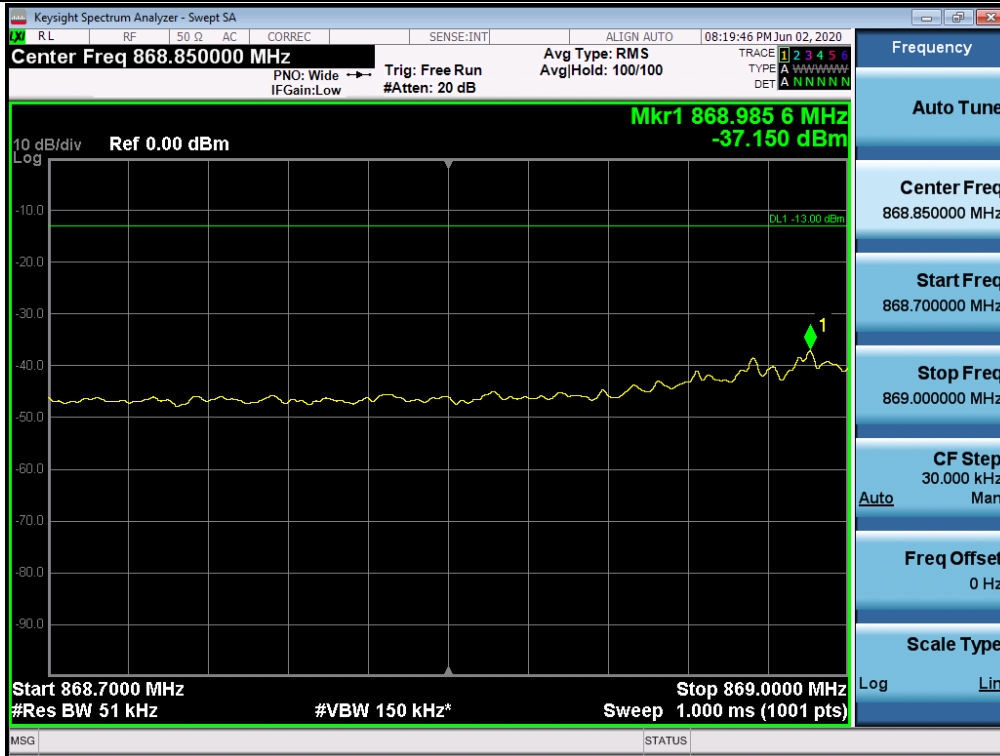

+3 dB above Out-of-band (two adjacent test signals) / Cellular / Downlink / LTE 5 MHz / Upper

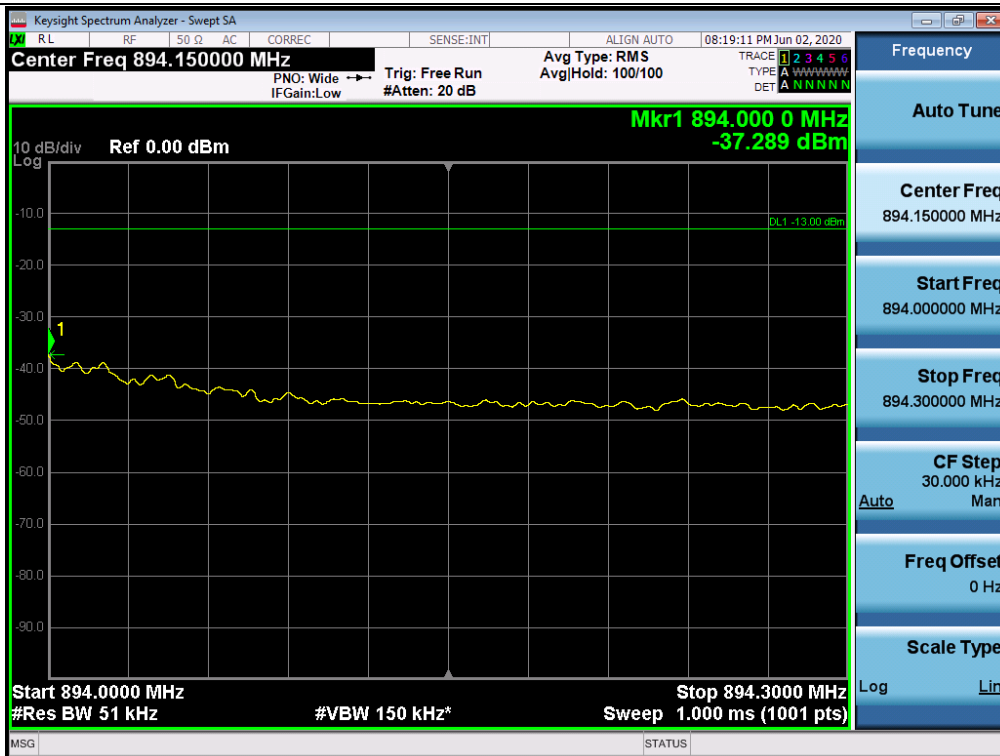

Out-of-band (two adjacent test signals) / Cellular / Downlink / LTE 10 MHz / Lower

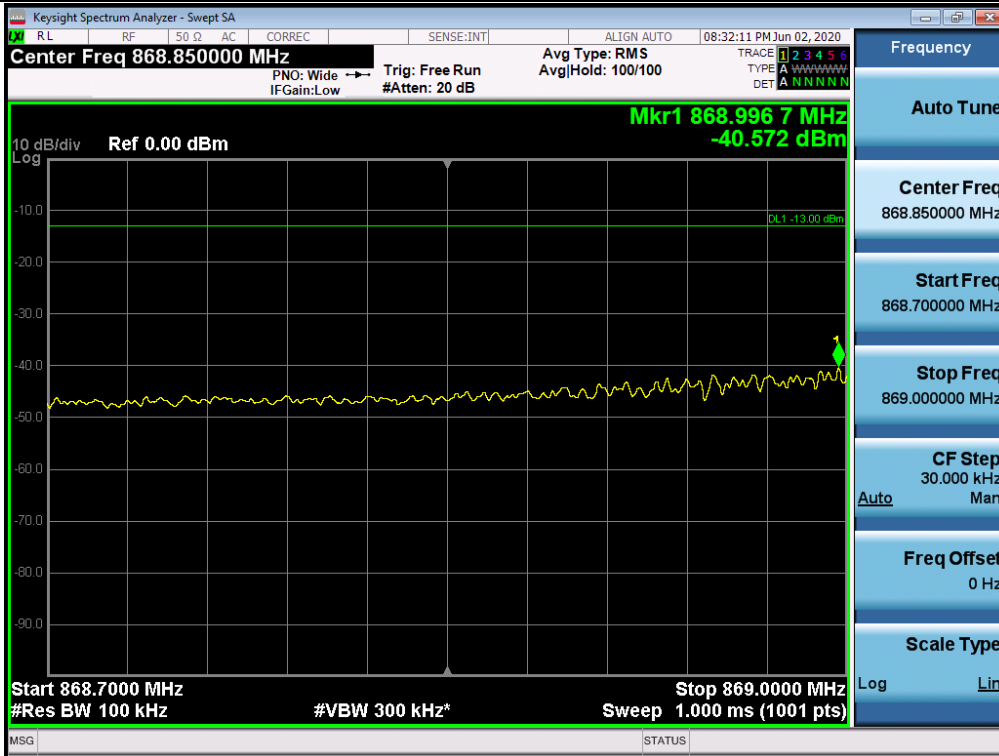

Out-of-band (two adjacent test signals) / Cellular / Downlink / LTE 10 MHz / Upper

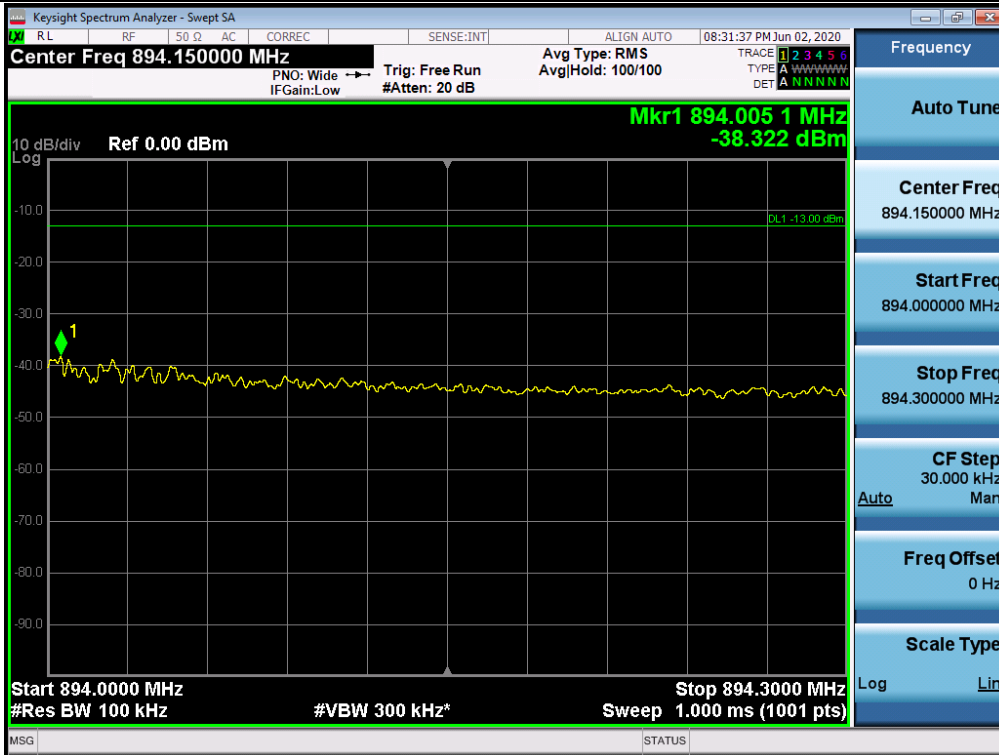

+3 dB above Out-of-band (two adjacent test signals) / Cellular / Downlink / LTE 10 MHz / Lower

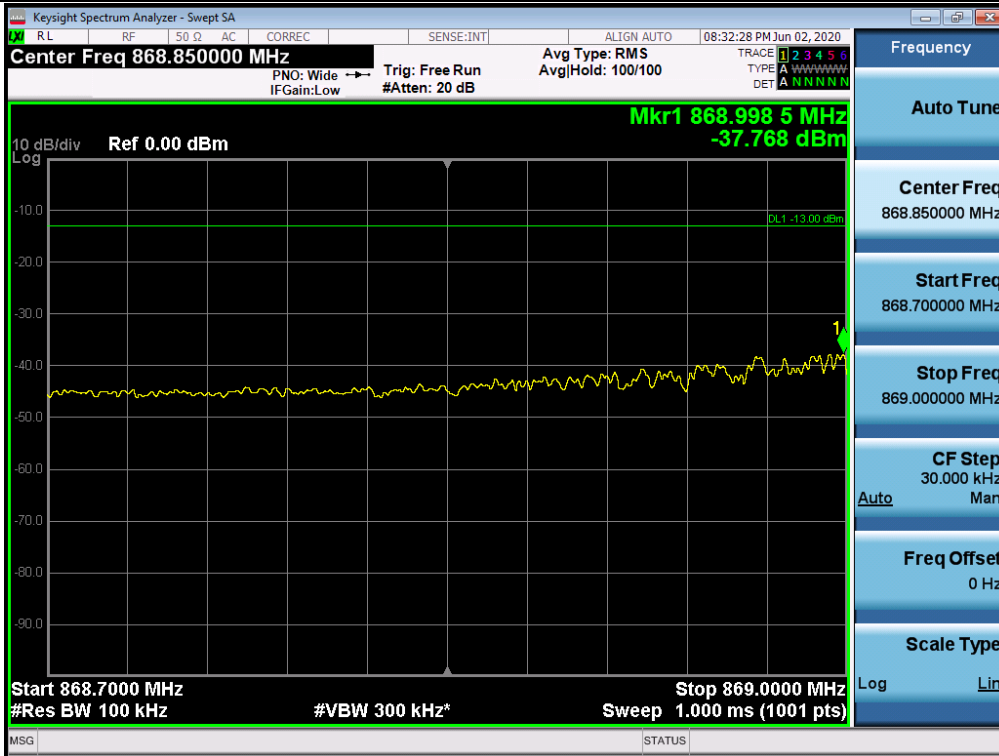

+3 dB above Out-of-band (two adjacent test signals) / Cellular / Downlink / LTE 10 MHz / Upper

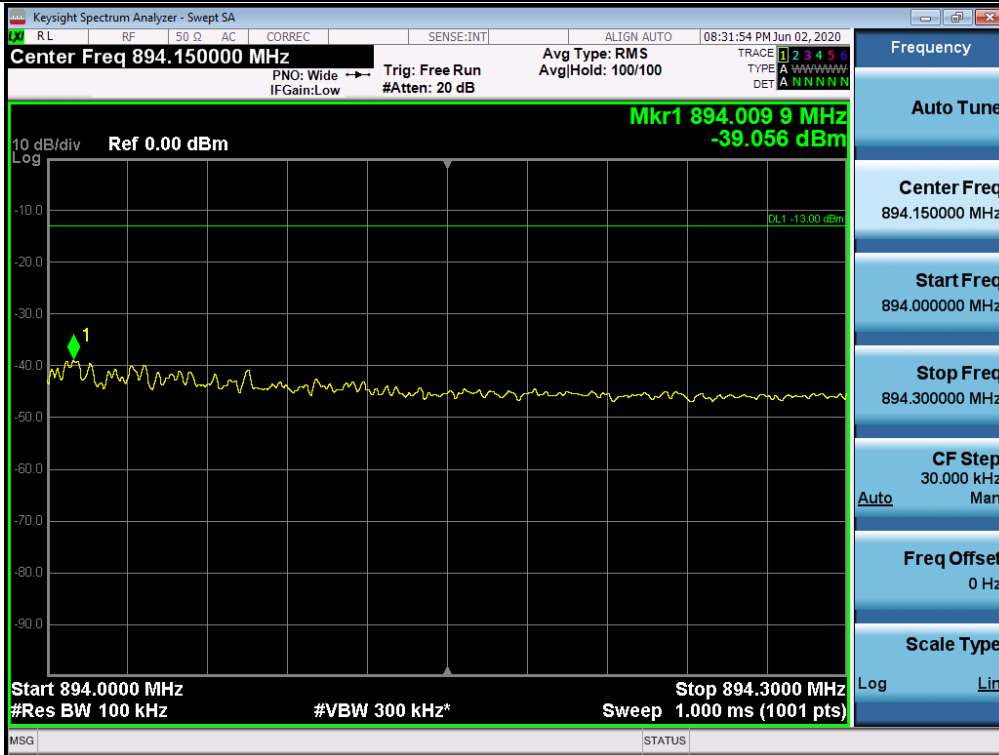

Out-of-band (two adjacent test signals) / WCS / Downlink / LTE 5 MHz / Lower

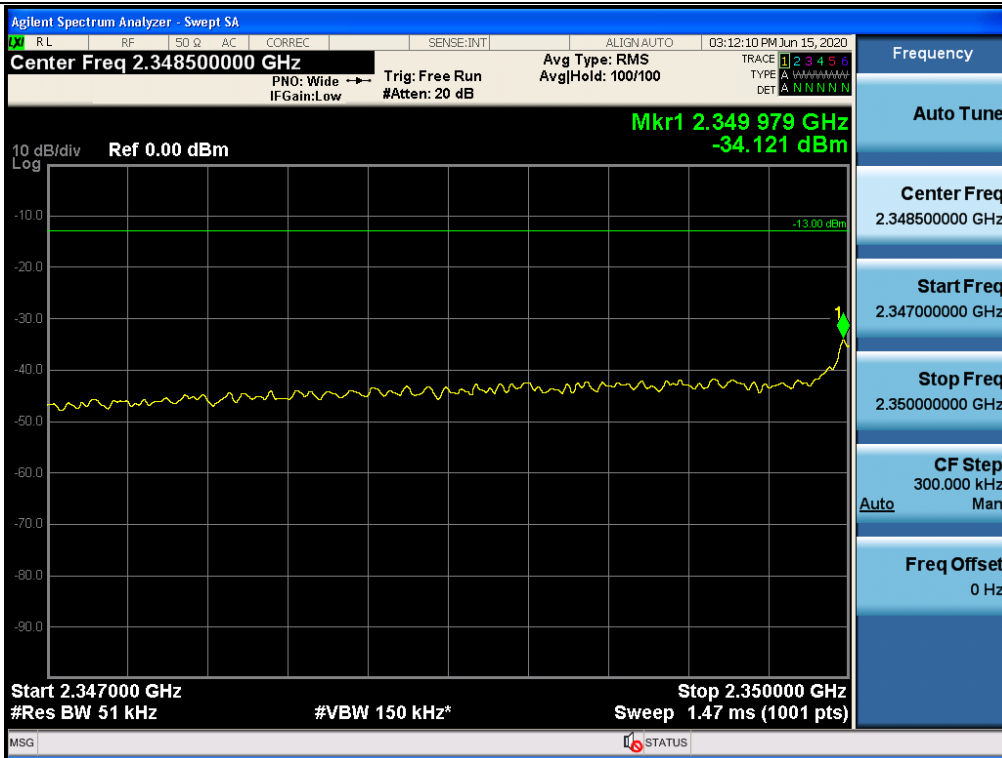

Out-of-band (two adjacent test signals) / WCS / Downlink / LTE 5 MHz / Upper

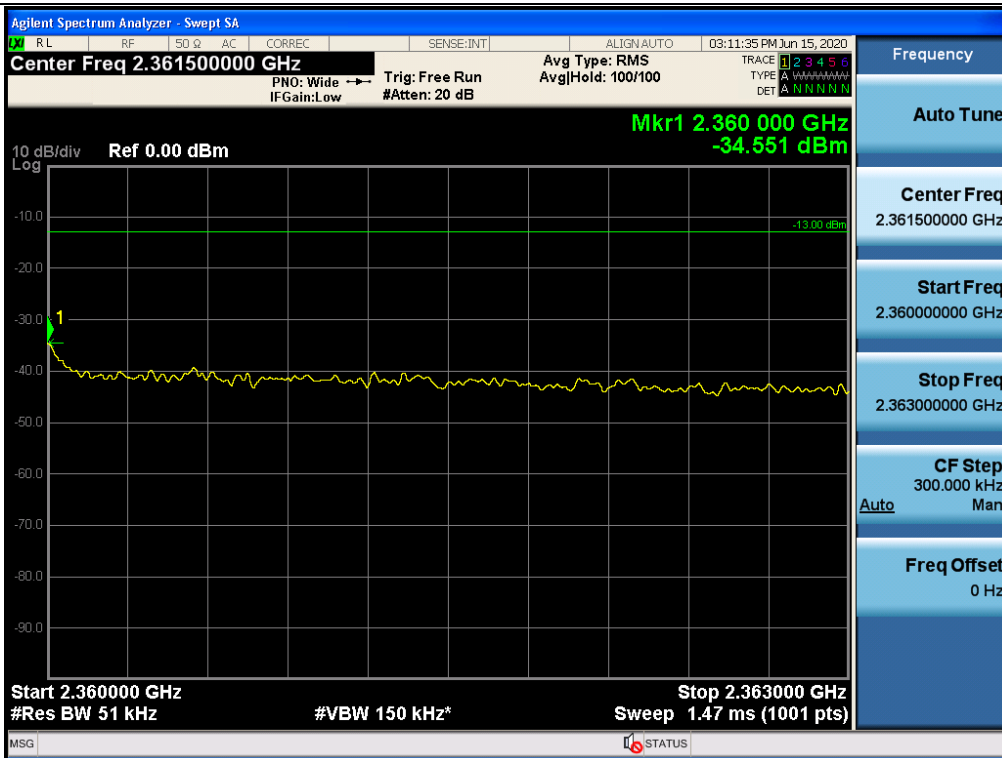

+3 dB above Out-of-band (two adjacent test signals) / WCS / Downlink / LTE 5 MHz / Lower

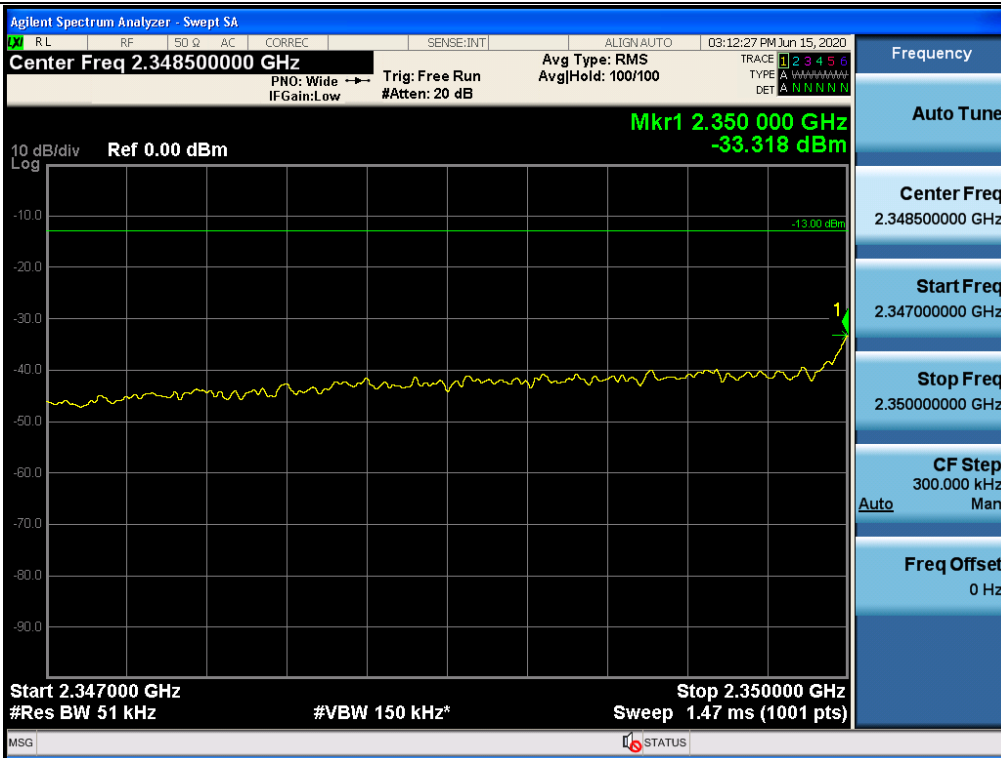

+3 dB above Out-of-band (two adjacent test signals) / WCS / Downlink / LTE 5 MHz / Upper

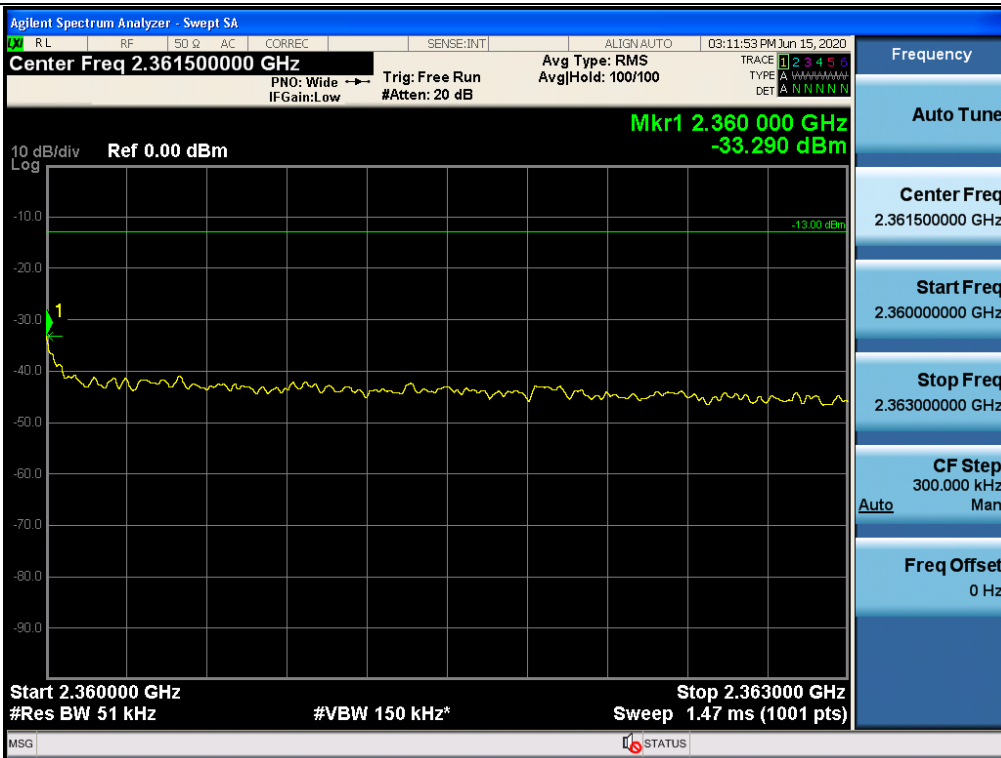

Out-of-band (single test signals) / 600 MHz / Downlink / LTE 5 MHz / Lower

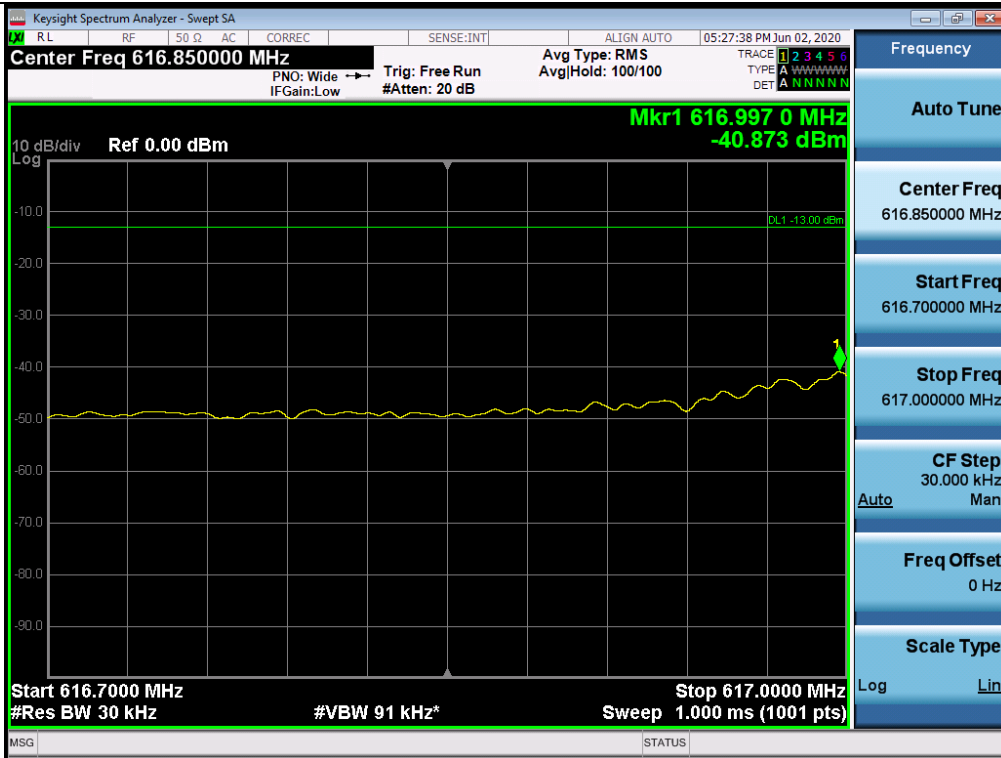

Out-of-band (single test signals) / 600 MHz / Downlink / LTE 5 MHz / Upper



+3 dB above Out-of-band (single test signals) / 600 MHz / Downlink / LTE 5 MHz / Lower

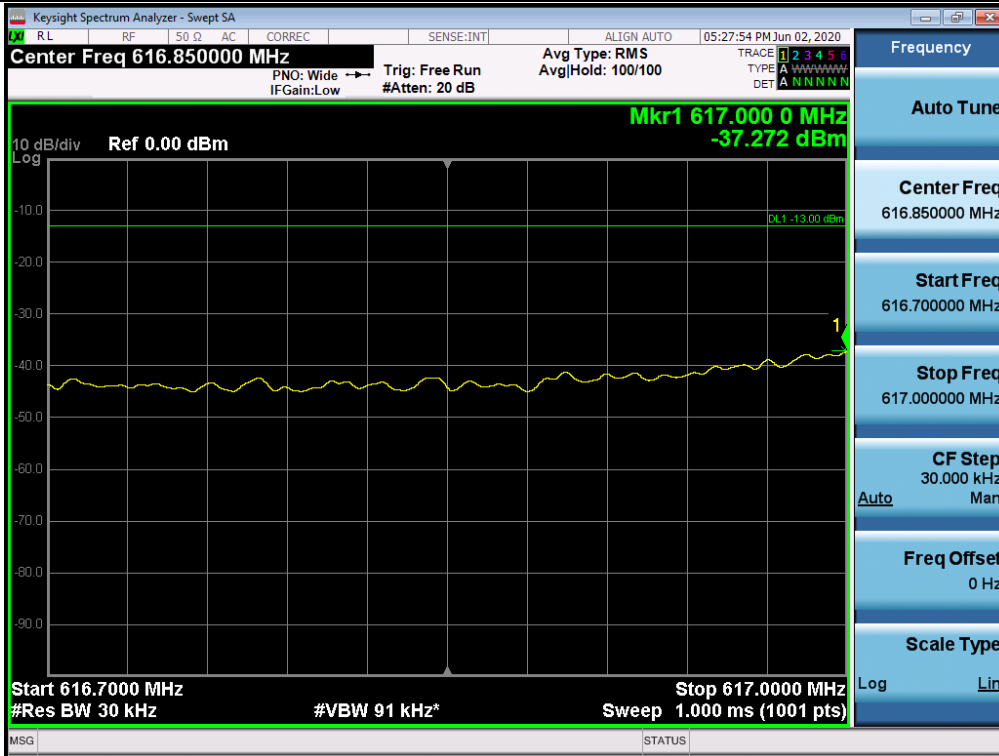

+3 dB above Out-of-band (single test signals) / 600 MHz / Downlink / LTE 5 MHz / Upper



Out-of-band (single test signals) / 600 MHz / Downlink / LTE 10 MHz / Lower

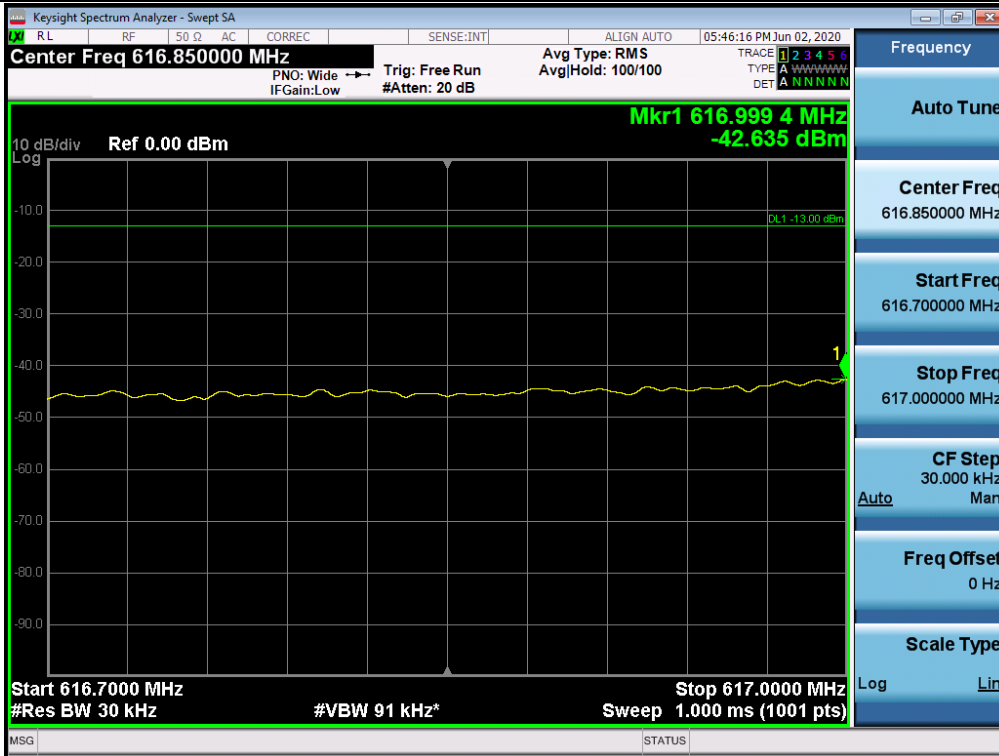

Out-of-band (single test signals) / 600 MHz / Downlink / LTE 10 MHz / Upper

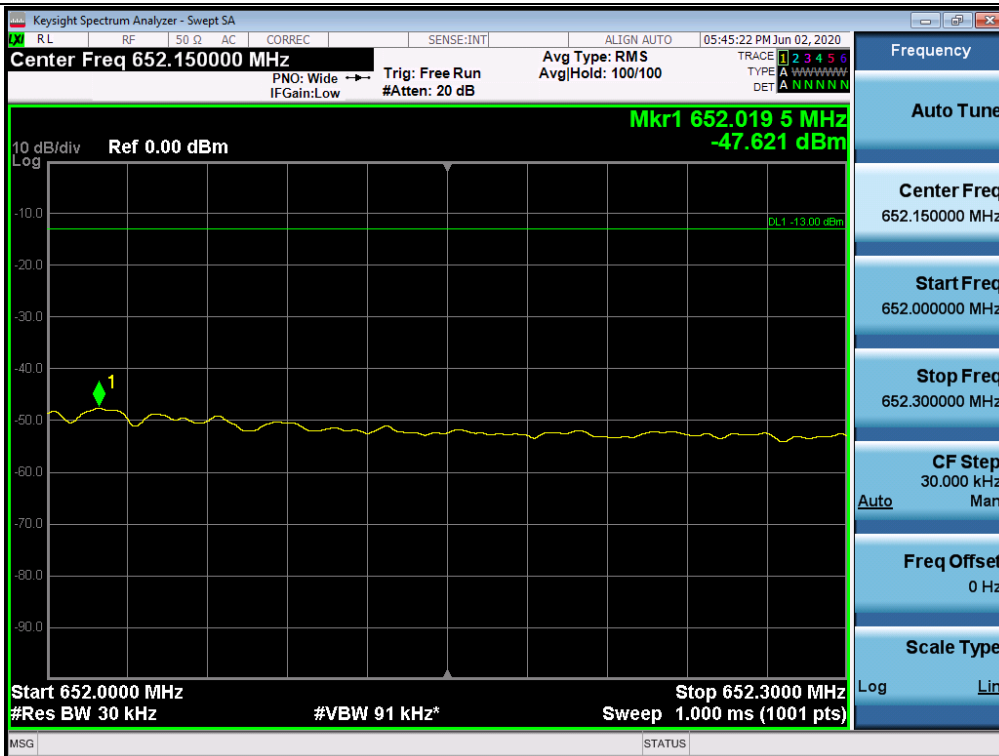

+3 dB above Out-of-band (single test signals) / 600 MHz / Downlink / LTE 10 MHz / Lower

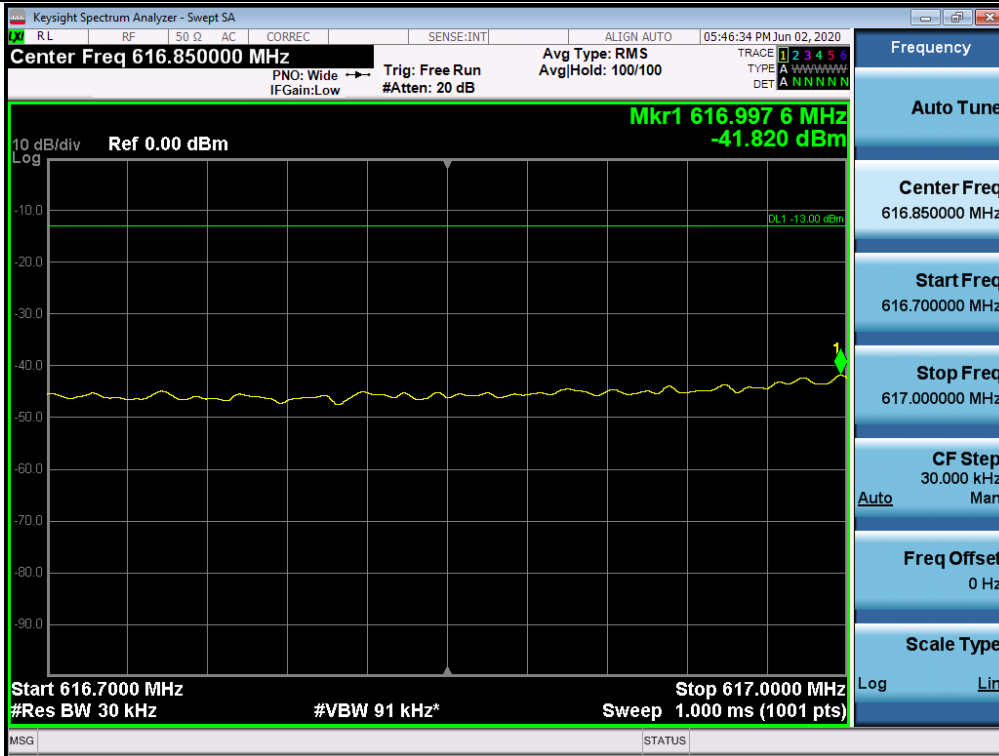

+3 dB above Out-of-band (single test signals) / 600 MHz / Downlink / LTE 10 MHz / Upper

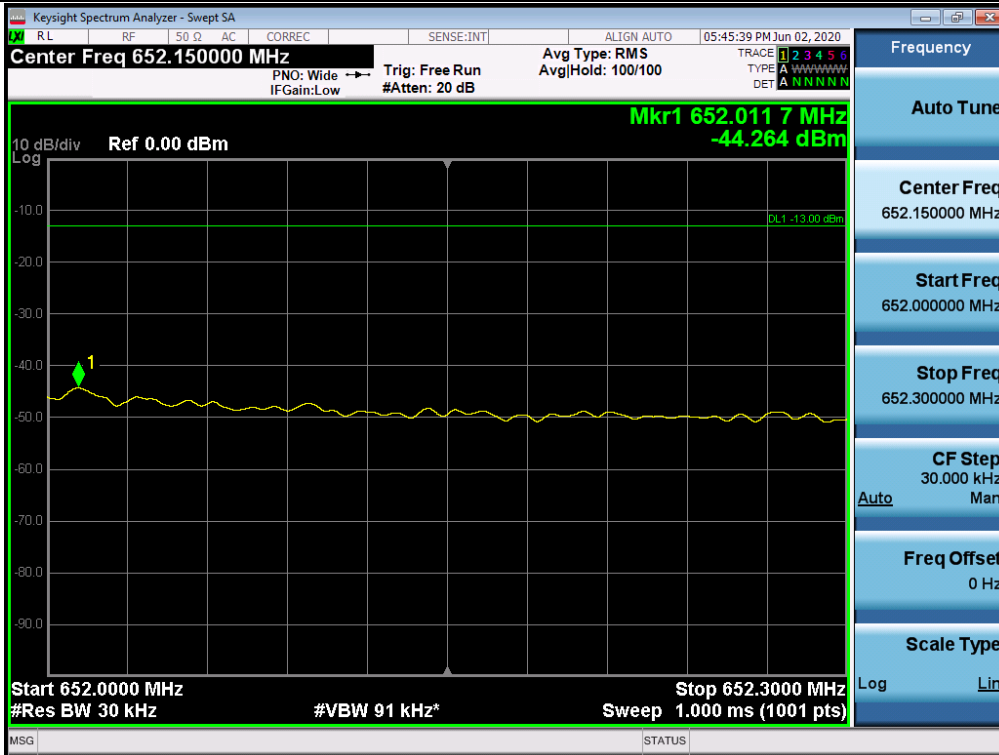

Out-of-band (single test signals) / 600 MHz / Downlink / LTE 20 MHz / Lower

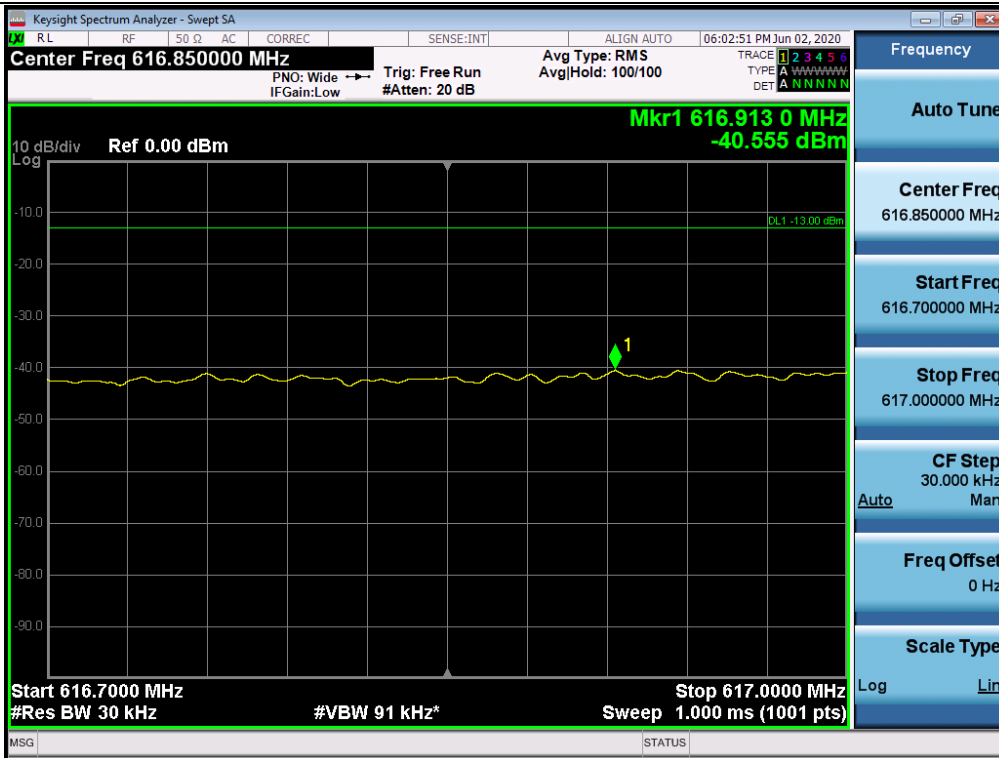

Out-of-band (single test signals) / 600 MHz / Downlink / LTE 20 MHz / Upper



+3 dB above Out-of-band (single test signals) / 600 MHz / Downlink / LTE 20 MHz / Lower

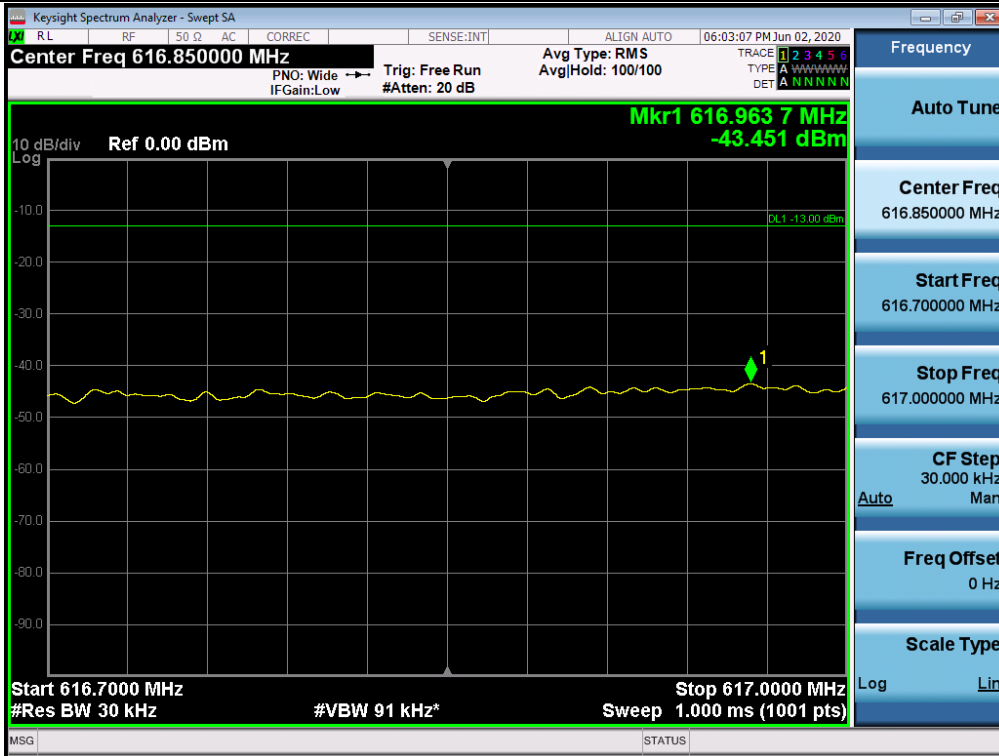

+3 dB above Out-of-band (single test signals) / 600 MHz / Downlink / LTE 20 MHz / Upper

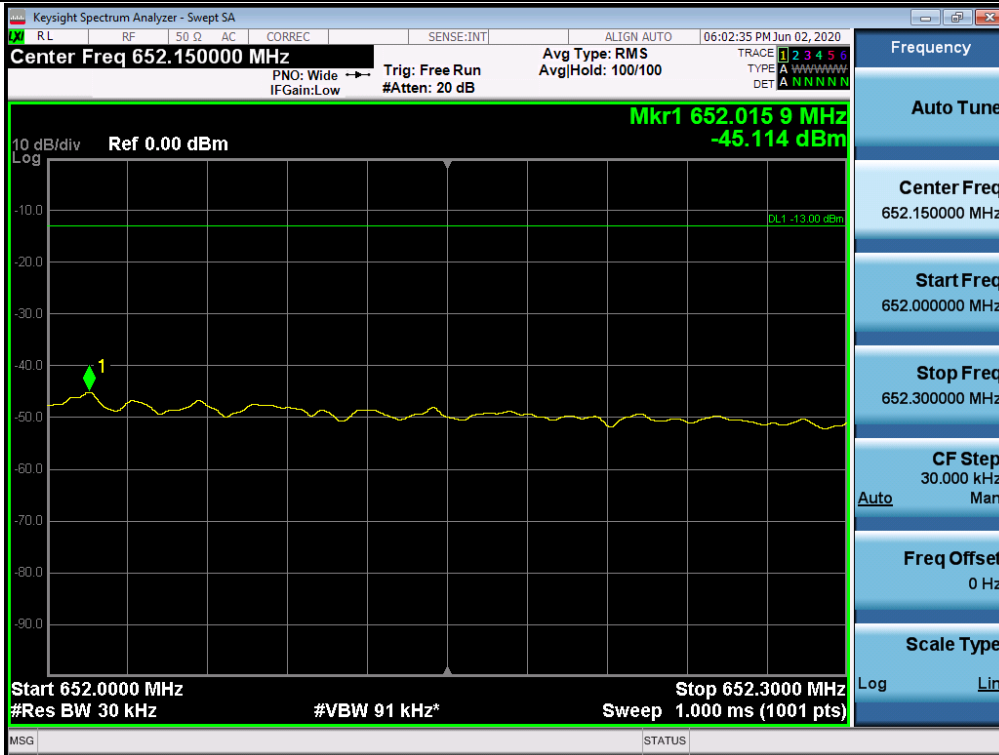

Out-of-band (single test signals) / ESMR / Downlink / CDMA / Lower



Out-of-band (single test signals) / ESMR / Downlink / CDMA / Upper

