

FCC TEST REPORT

For

Rosewill Inc.

300Mbps 802.11n/a/b/g Wireless Dual Band USB Adapter

Model No.: RNX-N600UBE

Prepared for : Rosewill Inc.
Address : 17708, Rowland Street, City of Industry, CA, 91748, United States

Prepared by : Shenzhen LCS Compliance Testing Laboratory Ltd.
Address : 1F., Xingyuan Industrial Park, Tongda Road, Bao'an Blvd., Bao'an District, Shenzhen, Guangdong, China

Date of receipt of test sample : January 22, 2013
Number of tested samples : 1
Serial number : Prototype
Date of Test : January 22, 2013 - February 28, 2013
Date of Report : February 28, 2013

FCC TEST REPORT
FCC CFR 47 PART 15 C(15.247)

Report Reference No. : **LCS130122282TF**

Date of Issue : February 28, 2013

Testing Laboratory Name..... : **Shenzhen LCS Compliance Testing Laboratory Ltd.**

Address : 1F., Xingyuan Industrial Park, Tongda Road, Bao'an Blvd.,
 Bao'an District, Shenzhen, Guangdong, China

Testing Location/ Procedure..... : Full application of Harmonised standards
 Partial application of Harmonised standards
 Other standard testing method

Applicant's Name..... : **Rosewill Inc.**

Address : 17708, Rowland Street, City of Industry, CA, 91748, United States

Test Specification

Standard : FCC CFR 47 PART 15 C(15.247)

Test Report Form No...... : LCSEMC-1.0

TRF Originator : Shenzhen LCS Compliance Testing Laboratory Ltd.

Master TRF : Dated 2011-03

SHENZHEN LCS COMPLIANCE TESTING LABORATORY LTD. All rights reserved.

This publication may be reproduced in whole or in part for non-commercial purposes as long as the Shenzhen LCS Compliance Testing Laboratory Ltd. is acknowledged as copyright owner and source of the material. Shenzhen LCS Compliance Testing Laboratory Ltd. takes no responsibility for and will not assume liability for damages resulting from the reader's interpretation of the reproduced material due to its placement and context.

Test Item Description. : **300Mbps 802.11n/a/b/g Wireless Dual Band USB Adapter**

Trade Mark : 

Model/ Type reference..... : RNX-N600UBE

Ratings : DC 5V

Result : **Positive**

Compiled by:

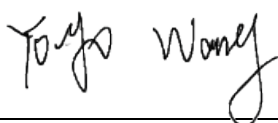

Yoyo Wang/ File administrators

Supervised by:



Vito Cao/ Technique principal

Approved by:



Gavin Liang/ Manager

FCC -- TEST REPORT

Test Report No. : LCS130122282TF	<u>February 28, 2013</u> Date of issue
---	---

Type / Model.....	: RNX-N600UBE
EUT.....	: 300Mbps 802.11n/a/b/g Wireless Dual Band USB Adapter
Applicant..... : Rosewill Inc.	
Address.....	: 17708, Rowland Street, City of Industry, CA, 91748, United States
Telephone.....	: /
Fax.....	: /
Manufacturer..... : ZIONCOM ELECTRONICS (SHENZHEN) LTD.	
Address.....	: Building A1~A2, Lantian Science Technology Park, Xinyu Road Xinqiao Henggang Block, Shajing Street, Baoan District, Shenzhen City, China
Telephone.....	: /
Fax.....	: /
Factory..... : ZIONCOM ELECTRONICS (SHENZHEN) LTD.	
Address.....	: Building A1~A2, Lantian Science Technology Park, Xinyu Road Xinqiao Henggang Block, Shajing Street, Baoan District, Shenzhen City, China
Telephone.....	: /
Fax.....	: /

Test Result:	Positive
---------------------	-----------------

The test report merely corresponds to the test sample.
 It is not permitted to copy extracts of these test result without the written permission of the test laboratory.

TABLE OF CONTENTS

1. GENERAL INFORMATION	5
1.1. DESCRIPTION OF DEVICE (EUT)	5
1.2. HOST SYSTEM CONFIGURATION LIST AND DETAILS	6
1.3. EXTERNAL I/O PORT	6
1.4. DESCRIPTION OF TEST FACILITY	7
1.5. STATEMENT OF THE MEASUREMENT UNCERTAINTY	7
1.6. MEASUREMENT UNCERTAINTY	7
1.7. DESCRIPTION OF TEST MODES	8
2. TEST METHODOLOGY	9
2.1. EUT CONFIGURATION	9
2.2. EUT EXERCISE	9
2.3. GENERAL TEST PROCEDURES	9
3. SYSTEM TEST CONFIGURATION	10
3.1. JUSTIFICATION	10
3.2. EUT EXERCISE SOFTWARE	10
3.3. SPECIAL ACCESSORIES	10
3.4. BLOCK DIAGRAM/SCHEMATICS	10
3.5. EQUIPMENT MODIFICATIONS	10
3.6. TEST SETUP	10
4. SUMMARY OF TEST RESULTS.....	11
5. TEST RESULT	12
5.1. MAXIMUM CONDUCTED OUTPUT POWER MEASUREMENT	12
5.2. POWER SPECTRAL DENSITY MEASUREMENT	15
5.3. 6 dB SPECTRUM BANDWIDTH MEASUREMENT	34
5.4. OCCUPIED BANDWIDTH	47
5.5. RADIATED EMISSIONS MEASUREMENT.....	60
5.6. CONDUCTED SPURIOUS EMISSIONS AND BAND EDGES TEST	73
5.7. POWER LINE CONDUCTED EMISSIONS	95
5.8. ANTENNA REQUIREMENTS.....	97
6. LIST OF MEASURING EQUIPMENTS.....	98
7. MANUFACTURER/ APPROVAL HOLDER DECLARATION	99

1. GENERAL INFORMATION

1.1. Description of Device (EUT)

EUT : 300Mbps 802.11n/a/b/g Wireless Dual Band USB Adapter

Model Number : RNX-N600UBE

Power Supply : DC 5V

Frequency Range : For 2.4GHz Band: 2412.00-2462.00MHz
For 5GHz Band: 5745.00-5825.00MHz

Channel Number : For 2.4GHz Band:
11 Channels for 20MHz Bandwidth
7 Channels for 40MHz Bandwidth
For 5GHz Band:
5 Channels for 20MHz Bandwidth
2 Channels for 40MHz Bandwidth

Modulation Technology : IEEE 802.11b: DSSS(CCK,DQPSK,DBPSK)
IEEE 802.11g: OFDM(64QAM, 16QAM, QPSK, BPSK)
IEEE 802.11n: OFDM (64QAM, 16QAM,QPSK,BPSK)
IEEE 802.11a: OFDM (64QAM, 16QAM,QPSK,BPSK)

Data Rates : IEEE 802.11b: 1-11Mbps
IEEE 802.11g: 6-54Mbps
IEEE 802.11n: MCS0-MCS15
IEEE 802.11a: 6-54Mbps

Antenna Type And Gain : Standard SMA connector Antenna(Fixed by Special glue)
Antenna 1: 4.0dBi(Max.)
Antenna 2: 4.0dBi(Max.)

1.2. Host System Configuration List and Details

Manufacturer	Description	Model	Serial Number	Certificate
Lenovo	Notebook	B470	--	DoC

1.3. External I/O Port

I/O Port Description	Quantity	Cable
USB Port	1	1.5m,unshielded

1.4. Description of Test Facility

Site Description

EMC Lab.

: Accredited by CNAS, June 04, 2010

The Certificate Registration Number. is L4595.

Accredited by FCC, July 14, 2011

The Certificate Registration Number. is 899208.

Accredited by Industry Canada, May. 02, 2011

The Certificate Registration Number. is 9642A-1

1.5. Statement of The Measurement Uncertainty

The data and results referenced in this document are true and accurate. The reader is cautioned that there may be errors within the calibration limits of the equipment and facilities. The measurement uncertainty was calculated for all measurements listed in this test report acc. To CISPR 16 – 4 “Specification for radio disturbance and immunity measuring apparatus and methods – Part 4: Uncertainty in EMC Measurements” and is documented in the LCS quality system acc. To DIN EN ISO/IEC 17025. Furthermore, component and process variability of devices similar to that tested may result in additional deviation. The manufacturer has the sole responsibility of continued compliance of the device.

1.6. Measurement Uncertainty

Test Item	Frequency Range	Uncertainty	Note
Radiation Uncertainty	9KHz~30MHz	± 3.10dB	(1)
	30MHz~200MHz	± 2.96dB	(1)
	200MHz~1000MHz	± 3.10dB	(1)
	1GHz~26.5GHz	± 3.80dB	(1)
	26.5GHz~40GHz	± 3.90dB	(1)
Conduction Uncertainty	150kHz~30MHz	± 1.63dB	(1)
Power disturbance	30MHz~300MHz	± 1.60dB	(1)

(1). This uncertainty represents an expanded uncertainty expressed at approximately the 95% confidence level using a coverage factor of k=2.

1.7. Description Of Test Modes

The EUT has been tested under operating condition.

This test was performed with EUT in X, Y, Z position and the worse case was found when EUT in X position.

Worst-case mode and channel used for 150kHz-30 MHz power line conducted emissions was the mode and channel with the highest output power, that was determined to be 802.11n HT20 mode(Low Channel, 2.4GHz Band).

Worst-case mode and channel used for 9kHz-1000 MHz radiated emissions was the mode and channel with the highest output power, that was determined to be 802.11n HT20 mode(Low Channel, 2.4GHz Band).

Worst-Case data rates were utilized from preliminary testing of the Chipset, worst-case data rates used during the testing are as follows:

For 2.4GHz Band:

802.11b Mode : 1 Mbps, DSSS.

802.11g Mode : 6 Mbps, OFDM.

802.11n Mode HT20:.MCS0, OFDM.

802.11n Mode HT40:.MCS0, OFDM.

For 5GHz Band:

802.11n Mode HT20:.MCS8, OFDM.

802.11n Mode HT40:.MCS8, OFDM.

802.11a Mode : 6 Mbps, OFDM.

Antenna & Bandwidth

Antenna	Single (Port.1)		Two (Port.1 + Port.2)	
	20MHz	40MHz	20MHz	40MHz
802.11a	<input checked="" type="checkbox"/>	<input type="checkbox"/>	<input type="checkbox"/>	<input type="checkbox"/>
802.11b	<input checked="" type="checkbox"/>	<input type="checkbox"/>	<input type="checkbox"/>	<input type="checkbox"/>
802.11g	<input checked="" type="checkbox"/>	<input type="checkbox"/>	<input type="checkbox"/>	<input type="checkbox"/>
802.11n	<input type="checkbox"/>	<input type="checkbox"/>	<input checked="" type="checkbox"/>	<input checked="" type="checkbox"/>

Channel List & Frequency

Frequency Band	Channel No.	Frequency(MHz)	Channel No.	Frequency(MHz)
2412~2462MHz	1	2412	7	2442
	2	2417	8	2447
	3	2422	9	2452
	4	2427	10	2457
	5	2432	11	2462
	6	2437	--	--

Frequency Band	Channel No.	Frequency(MHz)	Channel No.	Frequency(MHz)
5745~5825MHz Band 4	149	5745	159	5795
	151	5755	161	5805
	153	5765	165	5825
	157	5785	--	--

2. TEST METHODOLOGY

All measurements contained in this report were conducted with ANSI C63.4-2003, American National Standard for Methods of Measurement of Radio-Noise Emissions from Low-Voltage Electrical and Electronic Equipment in the range of 9 kHz to 40 GHz.

The radiated testing was performed at an antenna-to-EUT distance of 3 meters. All radiated and conducted emissions measurement was performed at Shenzhen LCS Compliance Testing Laboratory Ltd..

2.1. EUT Configuration

The EUT configuration for testing is installed on RF field strength measurement to meet the Commissions requirement and operating in a manner that intends to maximize its emission characteristics in a continuous normal application.

2.2. EUT Exercise

The EUT was operated in the engineering mode to fix the TX frequency that was for the purpose of the measurements.

According to FCC's request, Test Procedure KDB558074 D01 DTS Meas Guidance v02 and KDB 6622911 are required to be used for this kind of FCC 15.247 digital modulation device.

According to its specifications, the EUT must comply with the requirements of the Section 15.203, 15.205, 15.207, 15.209 and 15.247 under the FCC Rules Part 15 Subpart C.

2.3. General Test Procedures

2.3.1 Conducted Emissions

The EUT is placed on the turntable, which is 0.8 m above ground plane. According to the requirements in Section 13.1.4.1 of ANSI C63.4 Conducted emissions from the EUT measured in the frequency range between 0.15 MHz and 30MHz using Quasi-peak and average detector modes.

2.3.2 Radiated Emissions

The EUT is placed on a turn table, which is 0.8 m above ground plane. The turntable shall rotate 360 degrees to determine the position of maximum emission level. EUT is set 3m away from the receiving antenna, which varied from 1m to 4m to find out the highest emission. And also, each emission was to be maximized by changing the polarization of receiving antenna both horizontal and vertical. In order to find out the maximum emissions, exploratory radiated emission measurements were made according to the requirements in Section 13.1.4.1 of ANSI C63.4

3. SYSTEM TEST CONFIGURATION

3.1. Justification

The system was configured for testing in a continuous transmit condition.

3.2. EUT Exercise Software

N/A

3.3. Special Accessories

N/A

3.4. Block Diagram/Schematics

Please refer to the related document

3.5. Equipment Modifications

Shenzhen LCS Compliance Testing Laboratory Ltd. has not done any modification on the EUT.

3.6. Test Setup

Please refer to the test setup photo.

4. SUMMARY OF TEST RESULTS

Applied Standard: FCC Part 15 Subpart C		
FCC Rules	Description of Test	Result
§15.247(b)	Maximum Conducted Output Power	Compliant
§15.247(e)	Power Spectral Density	Compliant
§15.247(a)(2)	6dB Bandwidth	Compliant
§15.247(a)	Occupied Bandwidth	Compliant
§15.209, §15.247(d)	Radiated and Conducted Spurious Emissions	Compliant
§15.205	Emissions at Restricted Band	Compliant
§15.207(a)	Conducted Emissions	Compliant
§15.203	Antenna Requirements	Compliant
§15.247(i)§2.1093	RF Exposure	Compliant

5. TEST RESULT

5.1. Maximum Conducted Output Power Measurement

5.1.1. Standard Applicable

According to §15.247(b): For systems using digital modulation in the 2400-2483.5 MHz and 5725-5850 MHz band, the limit for maximum peak conducted output power is 30dBm. The limit has to be reduced by the amount in dB that the gain of the antenna exceeds 6dBi. In case of point-to-point operation, the limit has to be reduced by 1dB for every 3dB that the directional gain of the antenna exceeds 6dBi.

Systems operating in the 5725-5850 MHz band that are used exclusively for fixed, point-to-point operations may employ transmitting antennas with directional gain greater than 6 dBi without any corresponding reduction in transmitter peak output power.

5.1.2. Measuring Instruments and Setting

Please refer to section 6 of equipments list in this report. The following table is the setting of the power meter.

5.1.3. Test Procedures

The transmitter output (antenna port) was connected to the power meter.

5.1.4. Test Setup Layout

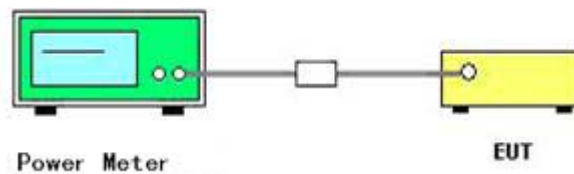

5.1.5. EUT Operation during Test

The EUT was programmed to be in continuously transmitting mode.

5.1.6. Test Result of Maximum Conducted Output Power

Temperature	25°C	Humidity	60%
Test Engineer	Leo	Configurations	802.11a/b/g/n

For 2.4GHz Band:

802.11b/Port.1

Channel	Frequency (MHz)	AV Conducted Power (dBm)	Max. Limit (dBm)	Result
1	2412	3.53	30	Complies
6	2437	3.11	30	Complies
11	2462	2.93	30	Complies

802.11g/Port.1

Channel	Frequency (MHz)	AV Conducted Power (dBm)	Max. Limit (dBm)	Result
1	2412	4.19	30	Complies
6	2437	4.01	30	Complies
11	2462	3.96	30	Complies

802.11n HT20

Channel	Frequency (MHz)	AV Conducted Power(dBm)			Max. Limit (dBm)	Result
		Port.1	Port.2	Port.1+Port.2		
1	2412	1.37	1.39	4.39	30	Complies
6	2437	1.33	1.31	4.33	30	Complies
11	2462	1.31	1.29	4.31	30	Complies

802.11n HT40

Channel	Frequency (MHz)	AV Conducted Power(dBm)			Max. Limit (dBm)	Result
		Port.1	Port.2	Port.1+Port.2		
3	2422	0.51	0.52	3.53	30	Complies
6	2437	0.50	0.49	3.51	30	Complies
9	2452	0.47	0.47	3.48	30	Complies

For 5GHz Band:

802.11n HT20

Channel	Frequency (MHz)	AV Conducted Power(dBm)			Max. Limit (dBm)	Result
		Port.1	Port.2	Port.1+Port.2		
149	5745	0.41	0.39	3.41	30	Complies
157	5785	0.39	0.38	3.40	30	Complies
165	5825	0.38	0.39	3.40	30	Complies

802.11n HT40

Channel	Frequency (MHz)	AV Conducted Power(dBm)			Max. Limit (dBm)	Result
		Port.1	Port.2	Port.1+Port.2		
151	5755	0.44	0.42	3.44	30	Complies
159	5795	0.43	0.41	3.43	30	Complies

802.11a/Port.1

Channel	Frequency (MHz)	AV Conducted Power (dBm)	Max. Limit (dBm)	Result
149	5745	3.41	30	Complies
157	5785	3.39	30	Complies
165	5825	3.36	30	Complies

5.2. Power Spectral Density Measurement

5.2.1. Standard Applicable

According to §15.247(e): For digitally modulated systems, the power spectral density conducted from the intentional radiator to the antenna shall not be greater than 8 dBm in any 3 kHz band during any time interval of continuous transmission.

5.2.2. Measuring Instruments and Setting

Please refer to section 6 of equipments list in this report. The following table is the setting of Spectrum Analyzer.

5.2.3. Test Procedures

1. The transmitter was connected directly to a Spectrum Analyzer through a directional couple.
2. The power was monitored at the coupler port with a Spectrum Analyzer. The power level was set to the maximum level.
3. Set the RBW = 3 kHz.
4. Set the VBW $\geq 3 \times$ RBW
5. Set the span to 1.5 times the DTS channel bandwidth.
6. Detector = peak.
7. Sweep time = auto couple.
8. Trace mode = max hold.
9. Allow trace to fully stabilize.
10. Use the peak marker function to determine the maximum power level in any 3 kHz band segment within the fundamental EBW.

5.2.4. Test Setup Layout

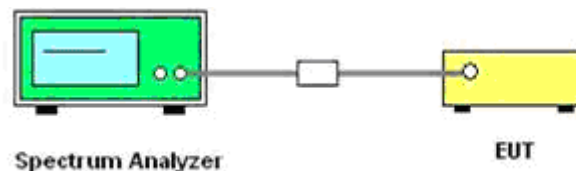

5.2.5. EUT Operation during Test

The EUT was programmed to be in continuously transmitting mode.

5.2.6. Test Result of Power Spectral Density

Temperature	25°C	Humidity	60%
Test Engineer	Leo	Configurations	802.11a/b/g/n

For 2.4GHz Band:

802.11b/Port.1

Channel	Frequency (MHz)	Power Density (dBm/3KHz)	Max. Limit (dBm/3KHz)	Result
1	2412	-23.06	8	Complies
6	2437	-23.35	8	Complies
11	2462	-23.93	8	Complies

802.11g/Port.1

Channel	Frequency (MHz)	Power Density (dBm/3KHz)	Max. Limit (dBm/3KHz)	Result
1	2412	-25.52	8	Complies
6	2437	-25.34	8	Complies
11	2462	-25.77	8	Complies

802.11n HT20

Channel	Frequency (MHz)	Power Density(dBm/3KHz)			Max. Limit (dBm/3KHz)	Result
		Port.1	Port.2	Port.1+Port.2		
1	2412	-27.49	-27.12	-24.29	8	Complies
6	2437	-27.74	-27.39	-24.55	8	Complies
11	2462	-27.21	-27.8	-24.48	8	Complies

802.11n HT40

Channel	Frequency (MHz)	Power Density (dBm/3KHz)			Max. Limit (dBm/3KHz)	Result
		Port.1	Port.2	Port.1+Port.2		
3	2422	-29.32	-28.5	-25.88	8	Complies
6	2437	-28.48	-29.12	-25.78	8	Complies
9	2452	-28.74	-27.26	-24.93	8	Complies

For 5GHz Band:

802.11n HT20

Channel	Frequency (MHz)	Power Density (dBm/3KHz)			Max. Limit (dBm/3KHz)	Result
		Port.1	Port.2	Port.1+Port.2		
149	5745	-27.27	-27.44	-24.34	8	Complies
157	5785	-28.08	-28.79	-25.41	8	Complies
165	5825	-27.05	-27.74	-24.37	8	Complies

802.11n HT40

Channel	Frequency (MHz)	Power Density (dBm/3KHz)			Max. Limit (dBm/3KHz)	Result
		Port.1	Port.2	Port.1+Port.2		
151	5755	-28	-23.48	-22.17	8	Complies
159	5795	-24.3	-25.23	-21.73	8	Complies

802.11a/Port.1

Channel	Frequency (MHz)	Power Density (dBm/3KHz)	Max. Limit (dBm/3KHz)	Result
149	5745	-27.08	8	Complies
157	5785	-28.05	8	Complies
165	5825	-27.44	8	Complies

Test Plots of 2.4GHz Band

802.11b power density / port.1

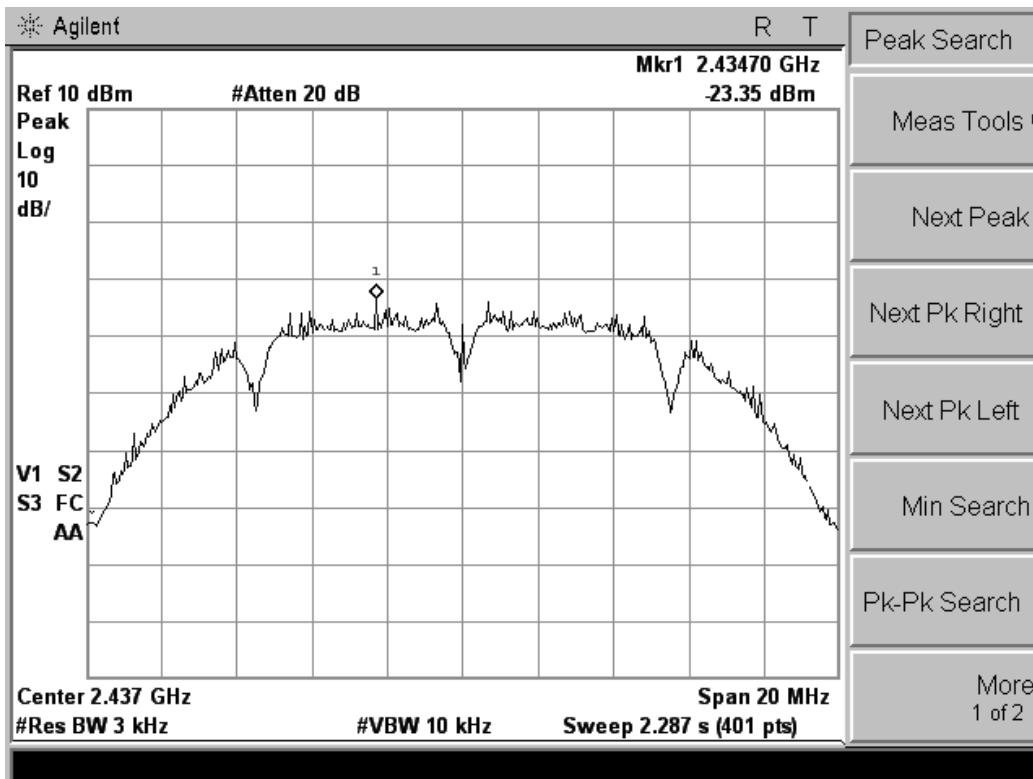
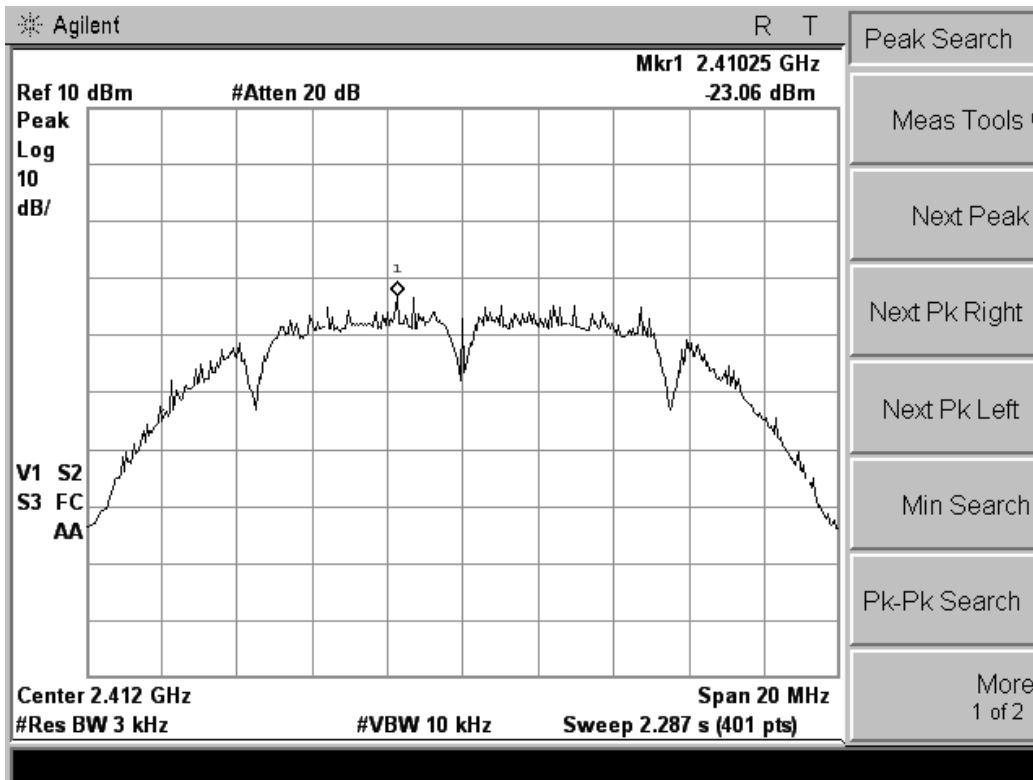

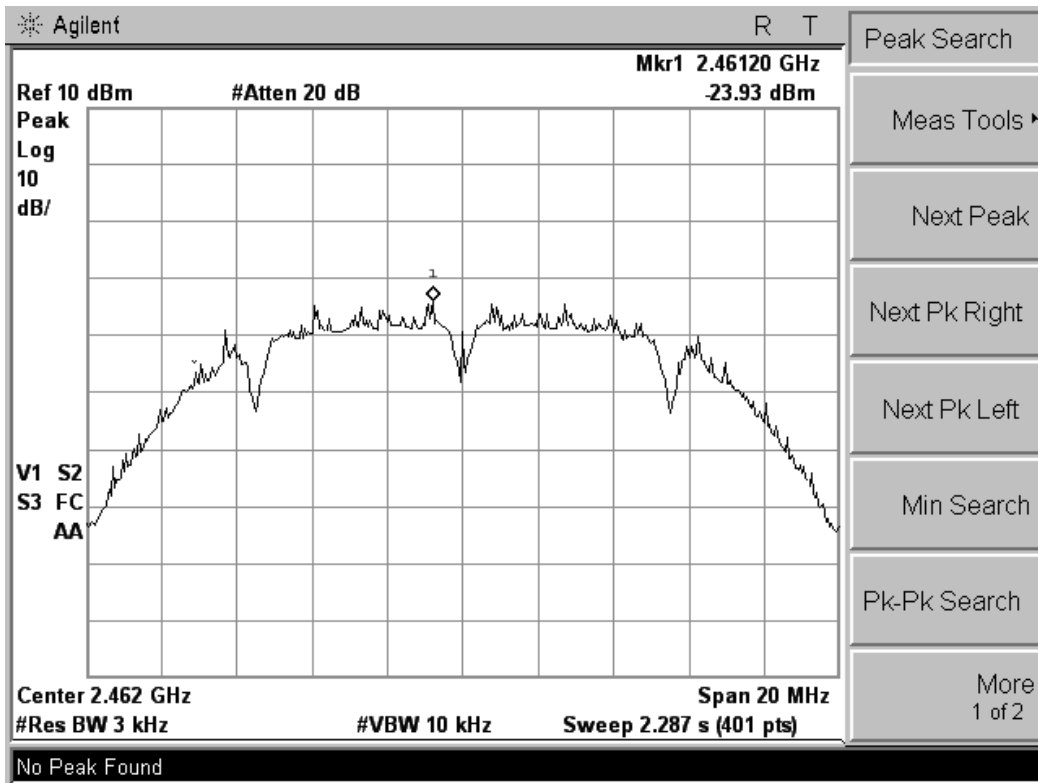

802.11g power density / port.1

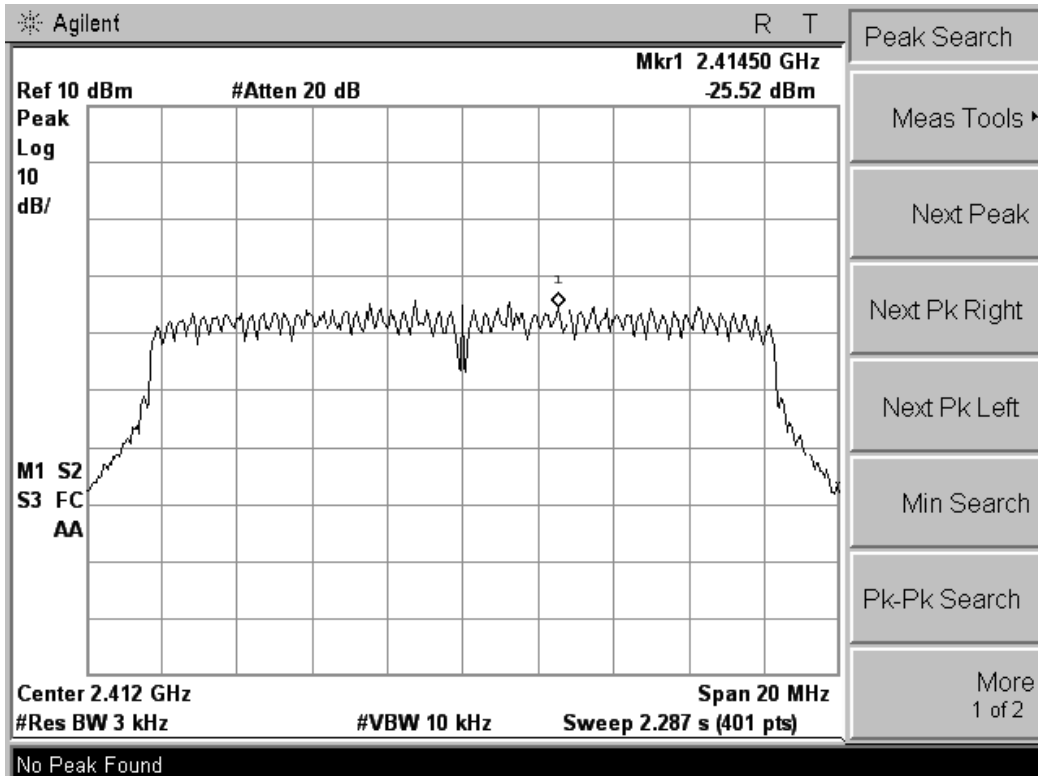

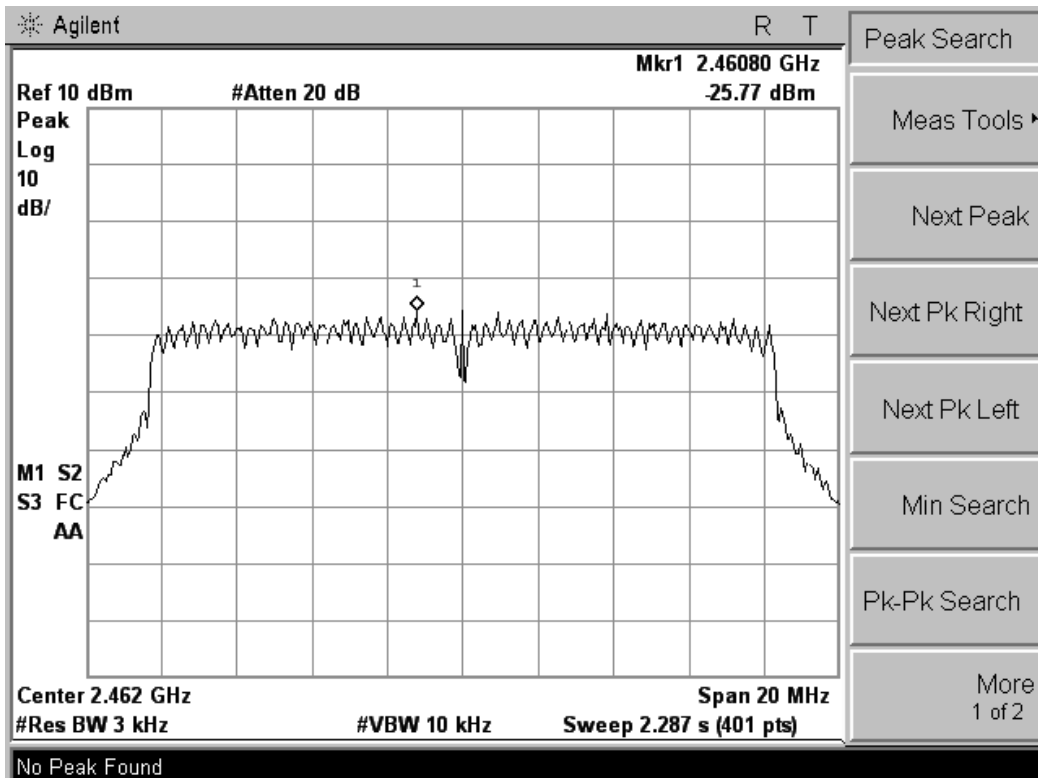
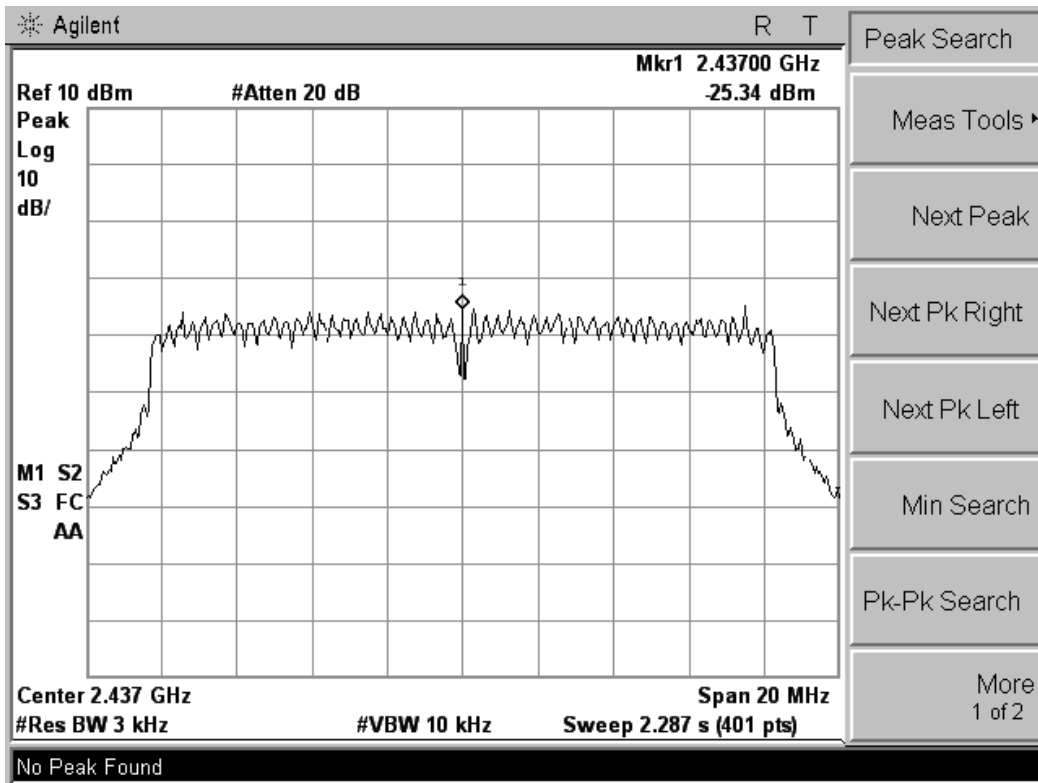

802.11n HT20 power density / port.1

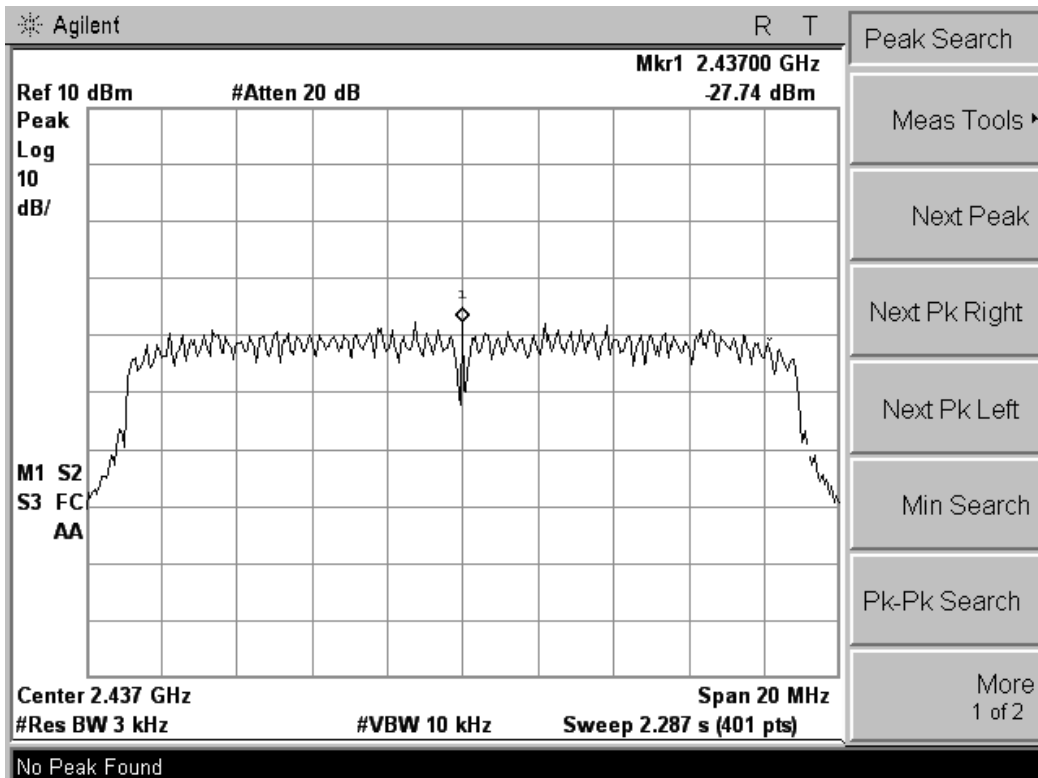
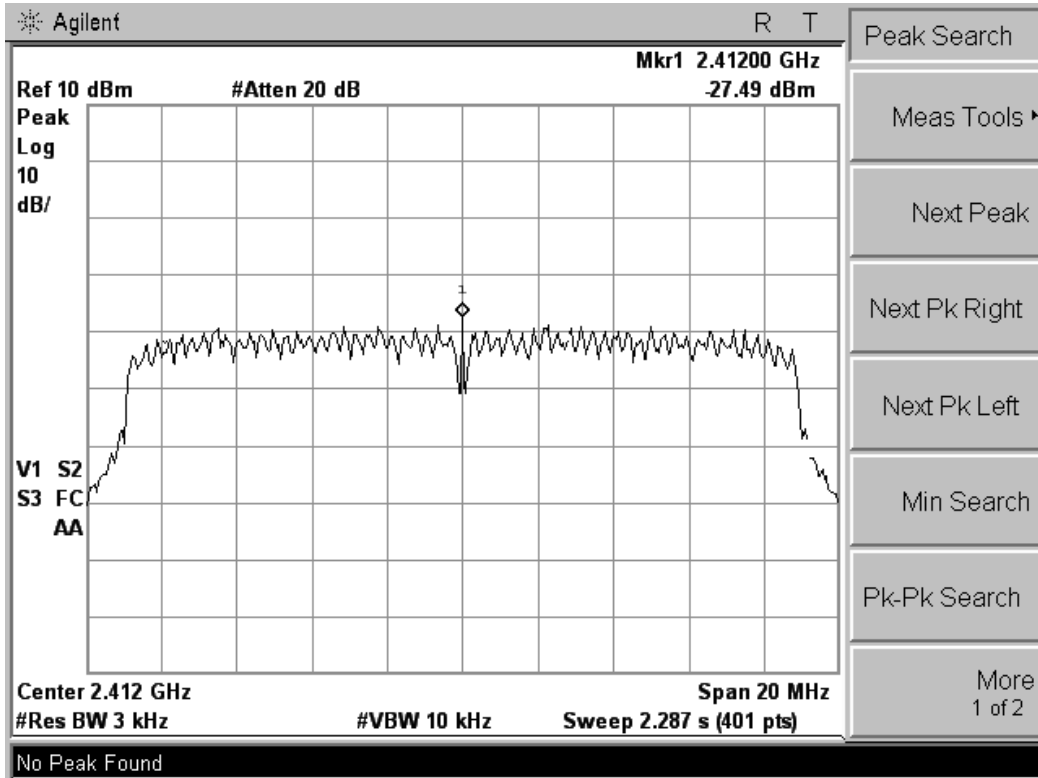

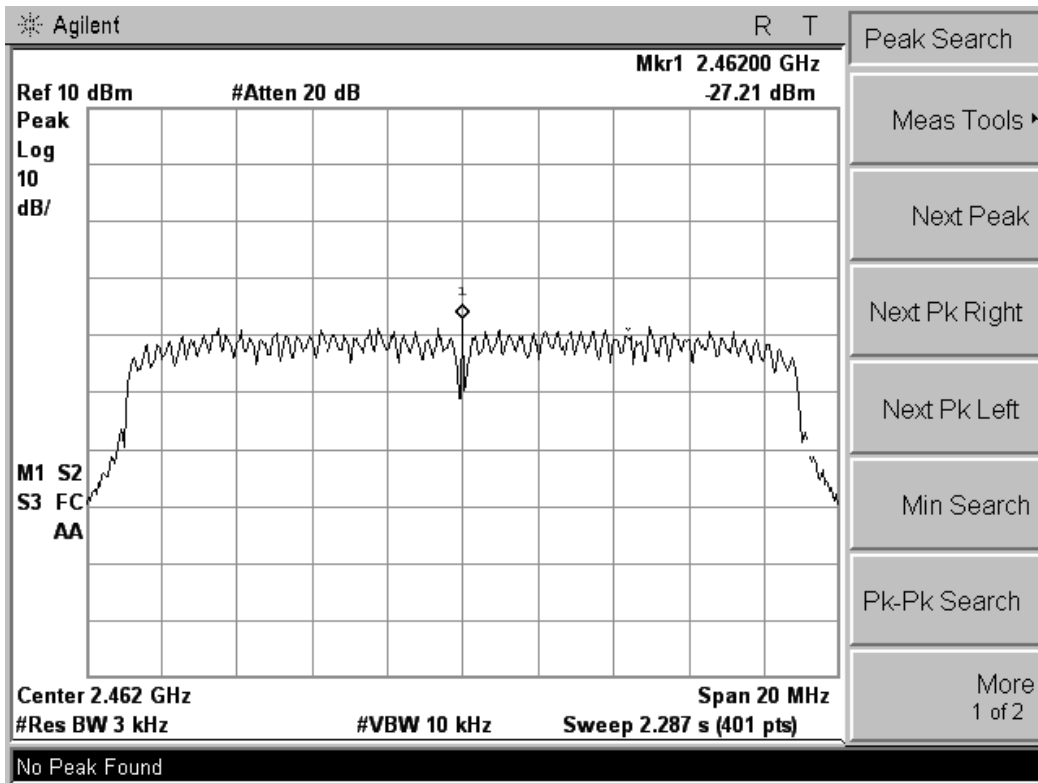

802.11n HT20 power density / port.2

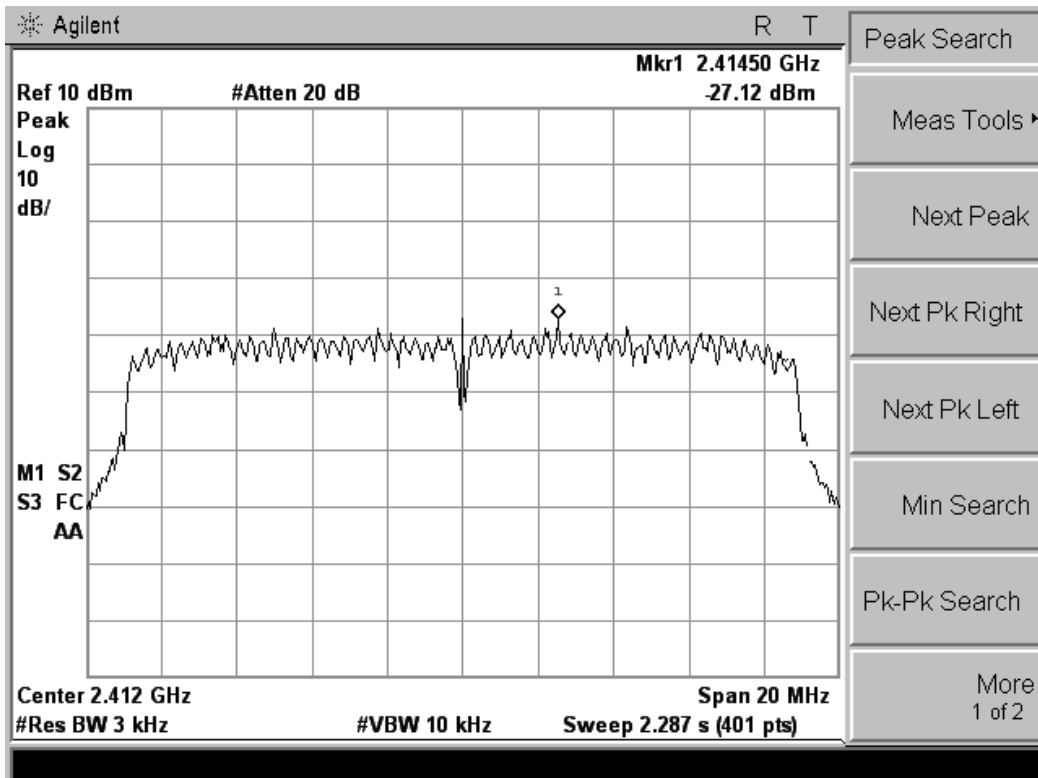

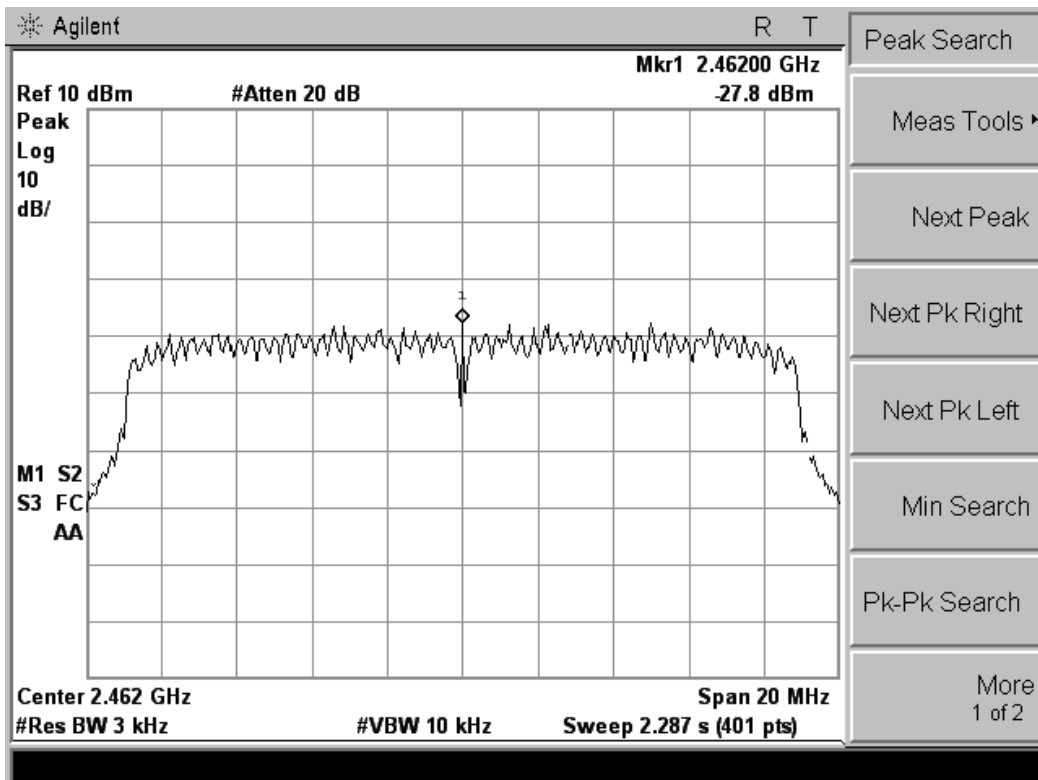
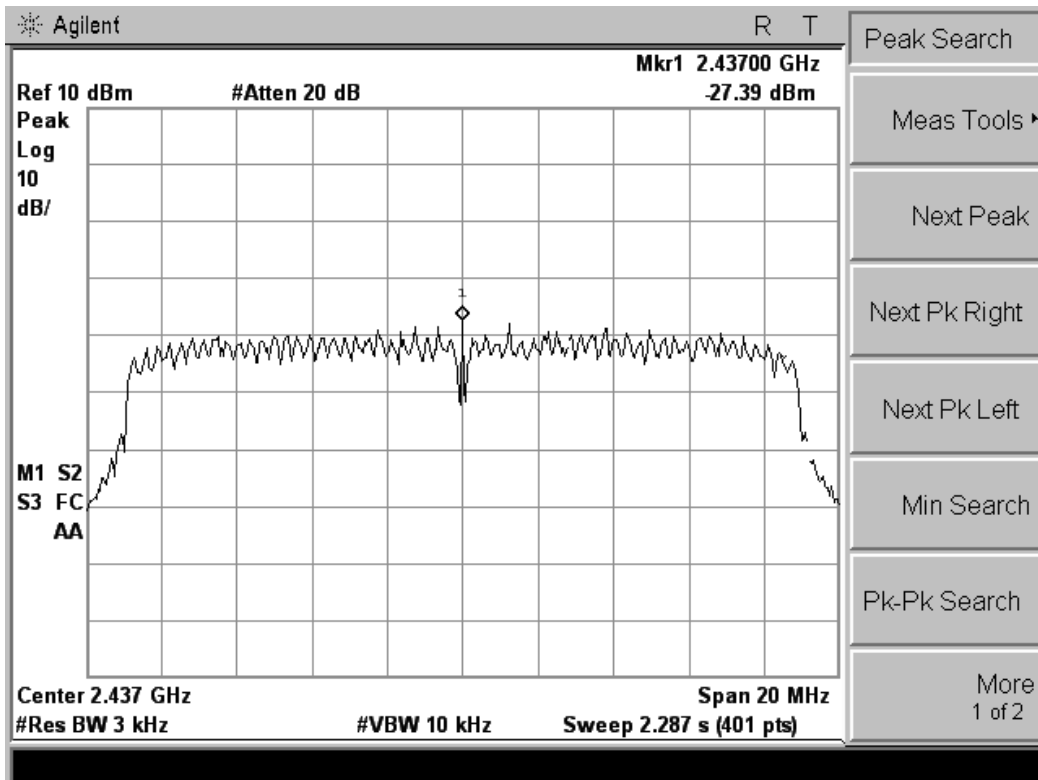

802.11n HT40 power density / port.1

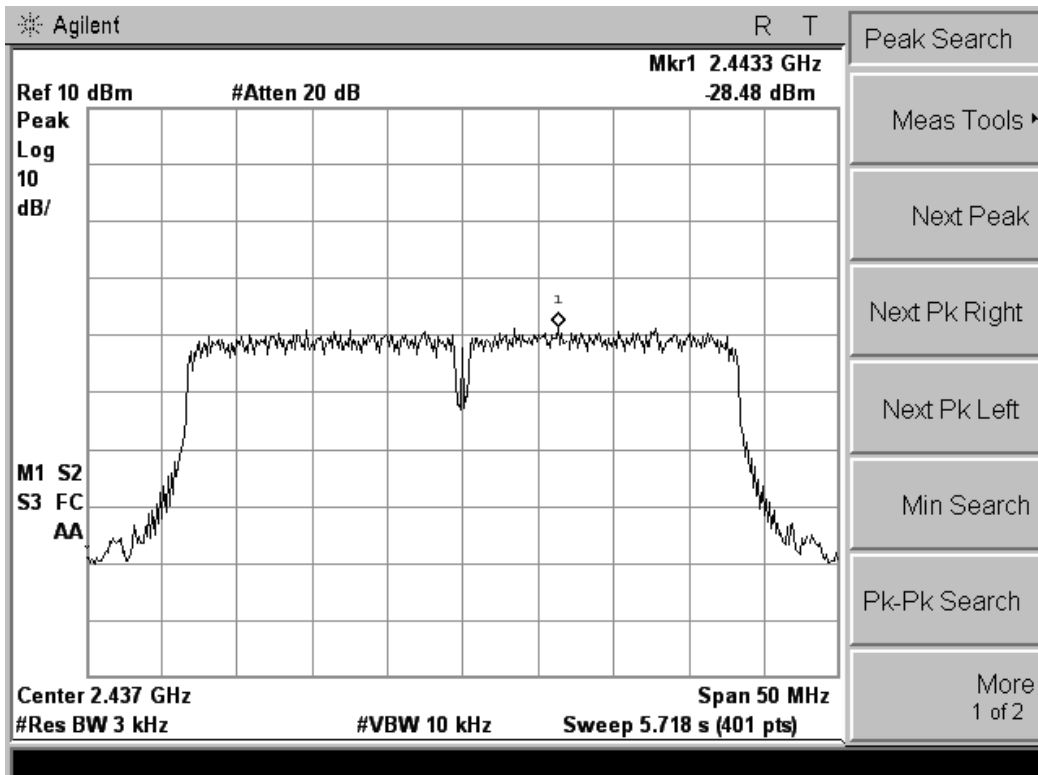
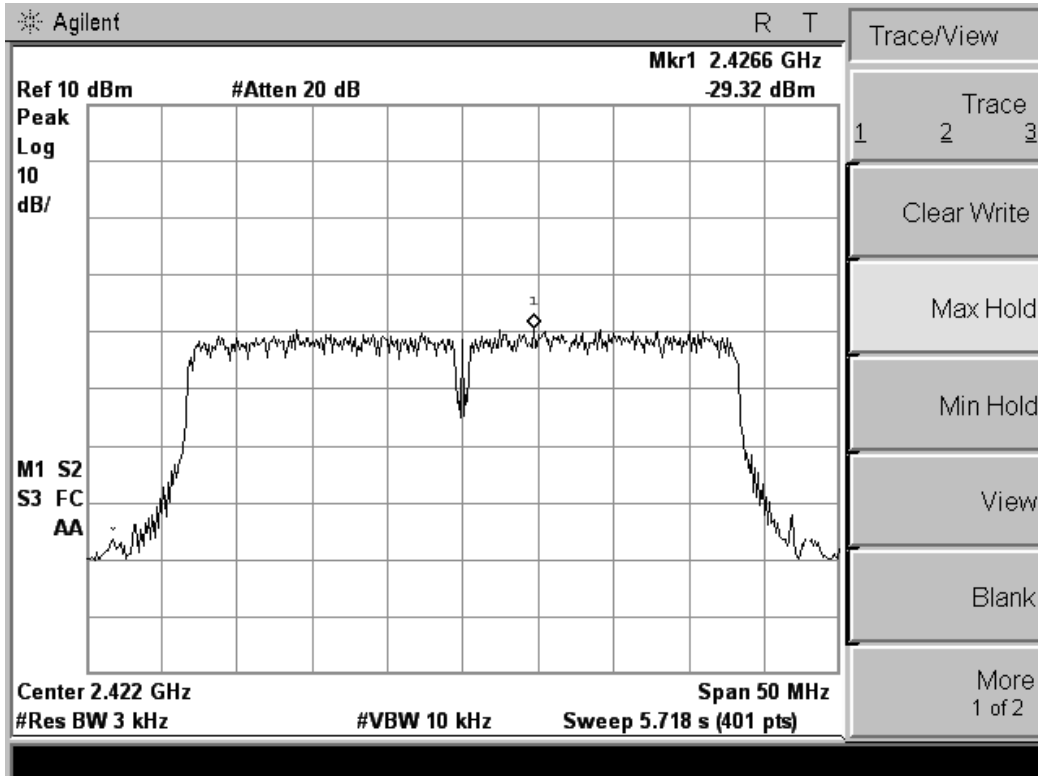

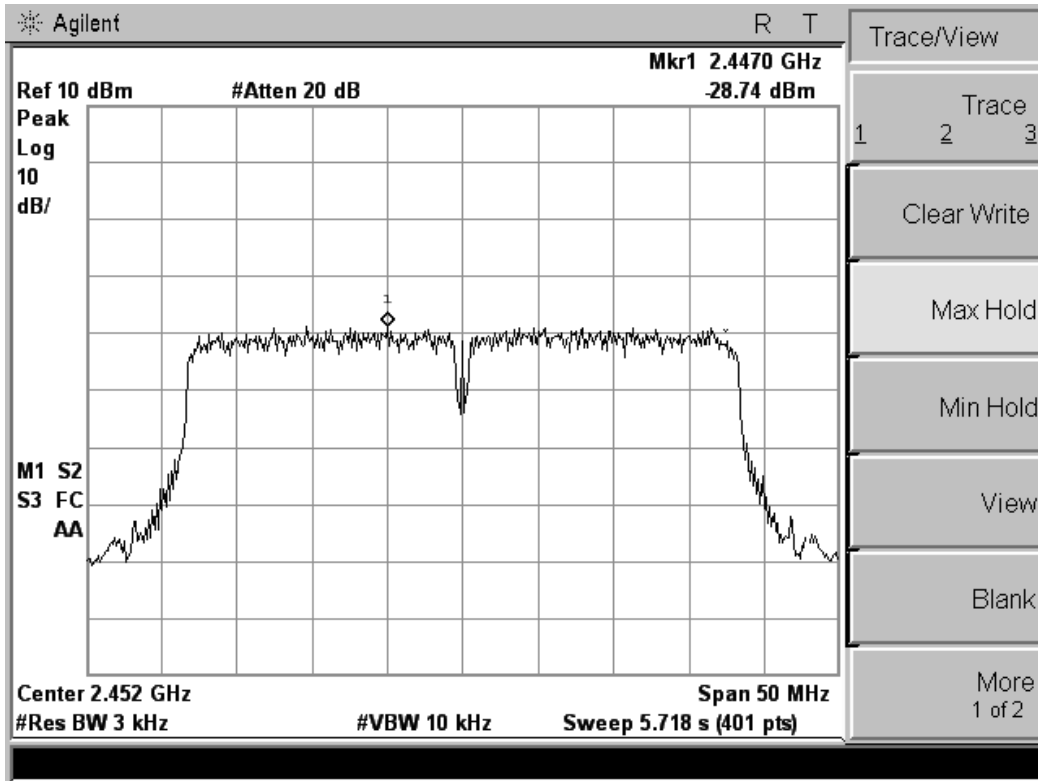

802.11n HT40 power density / port.2

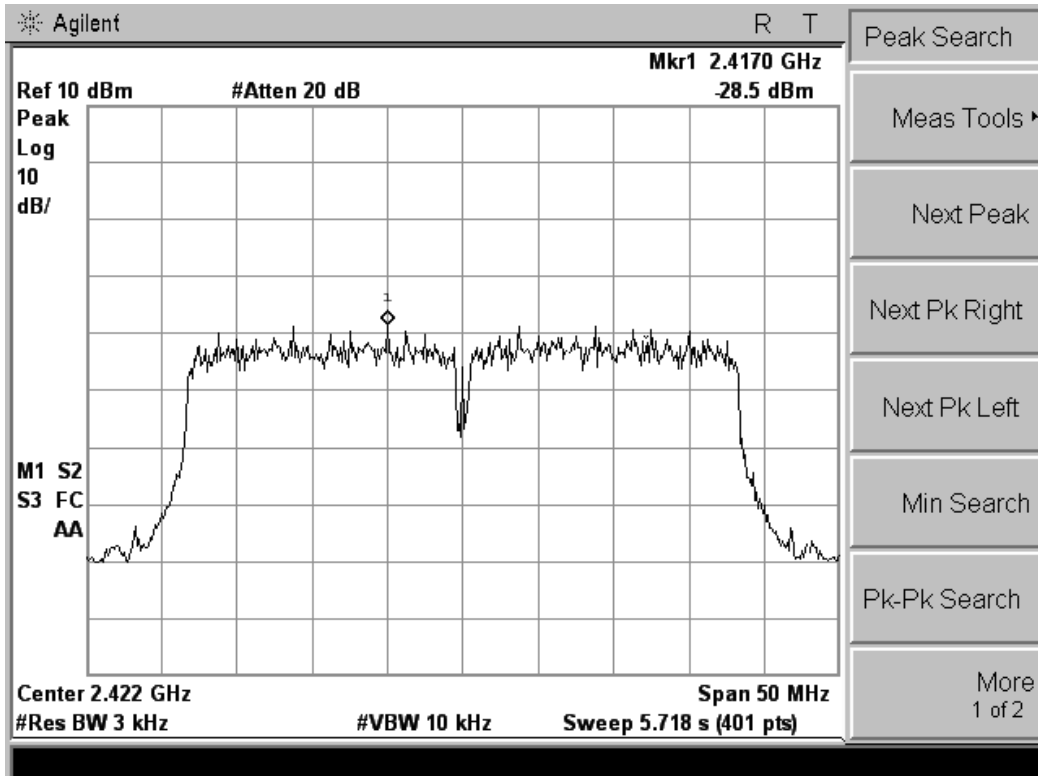

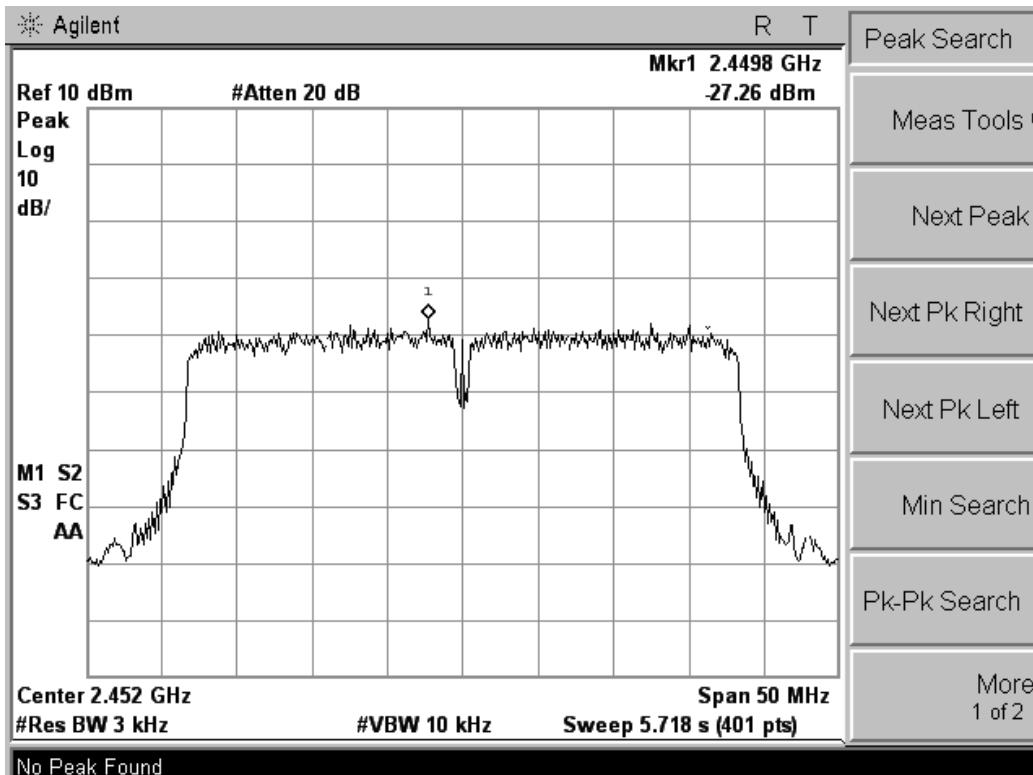
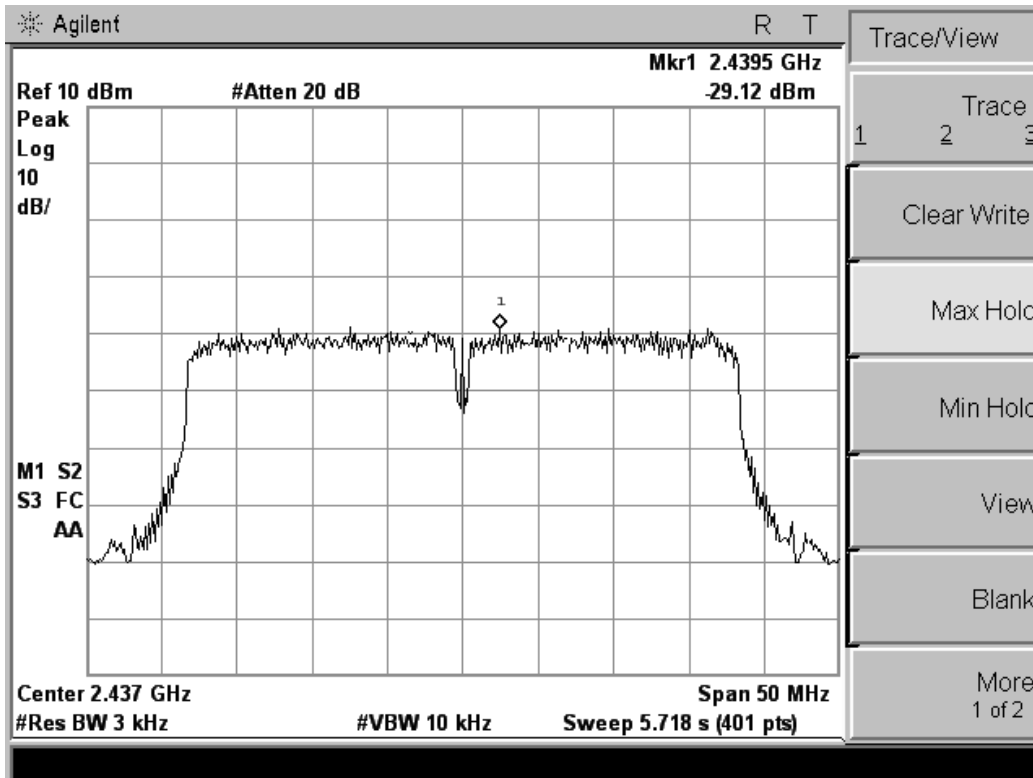

Test Plots of 5GHz Band
802.11n HT20 power density / port.1

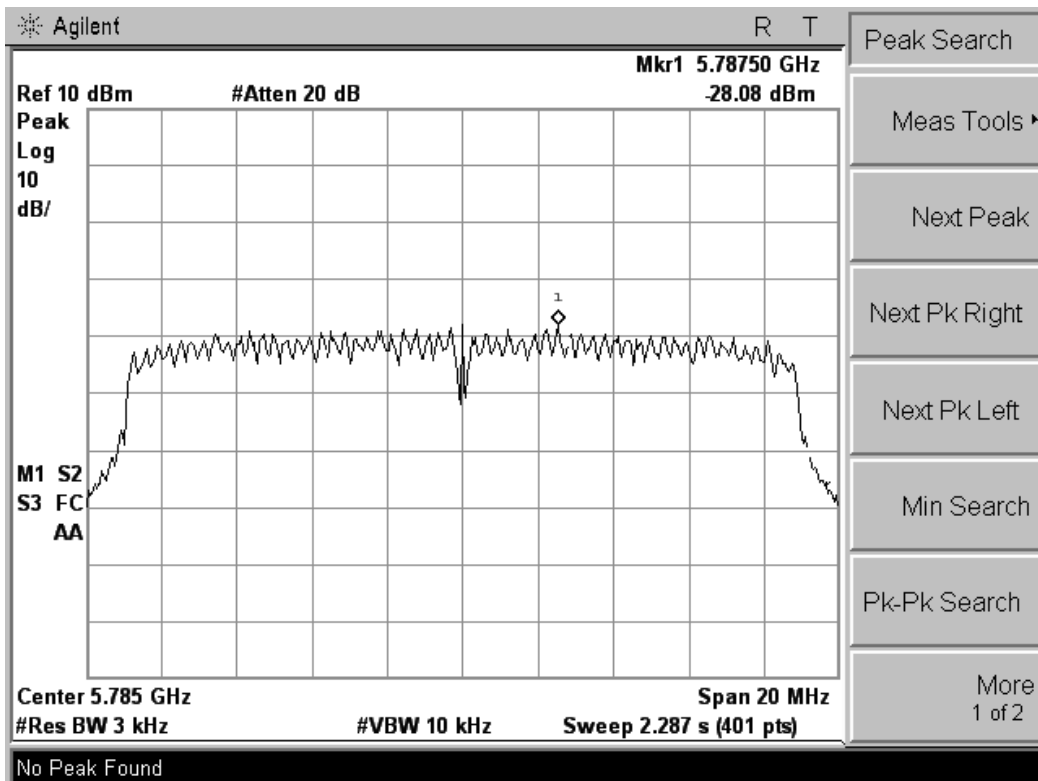
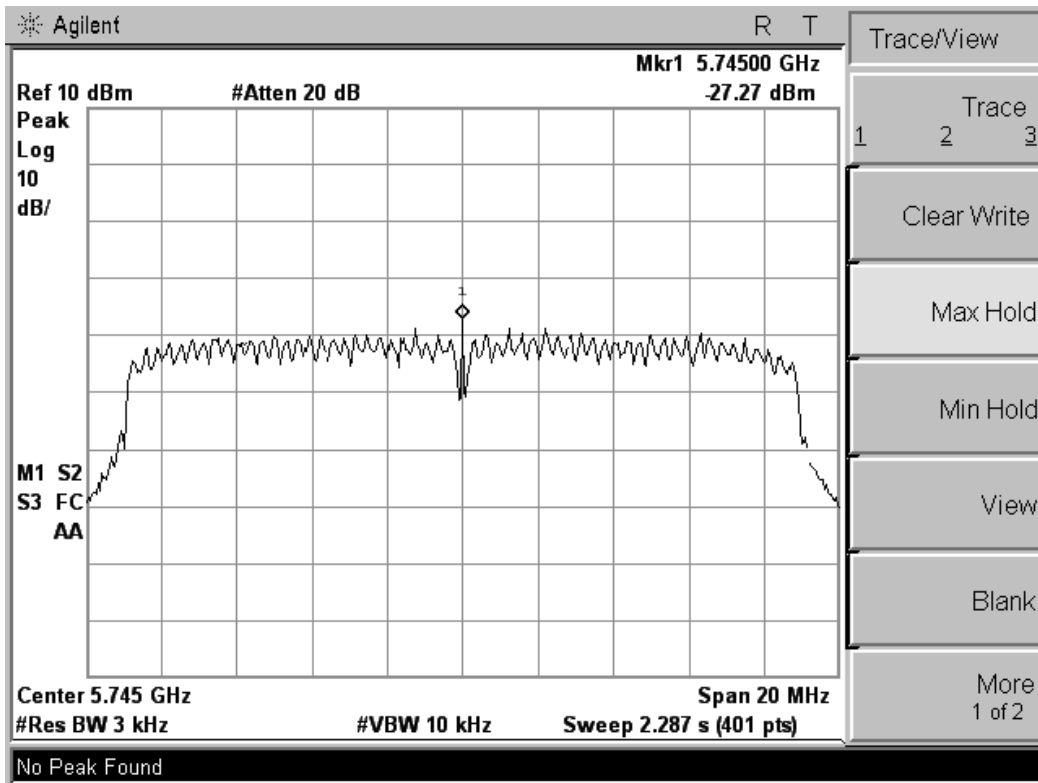

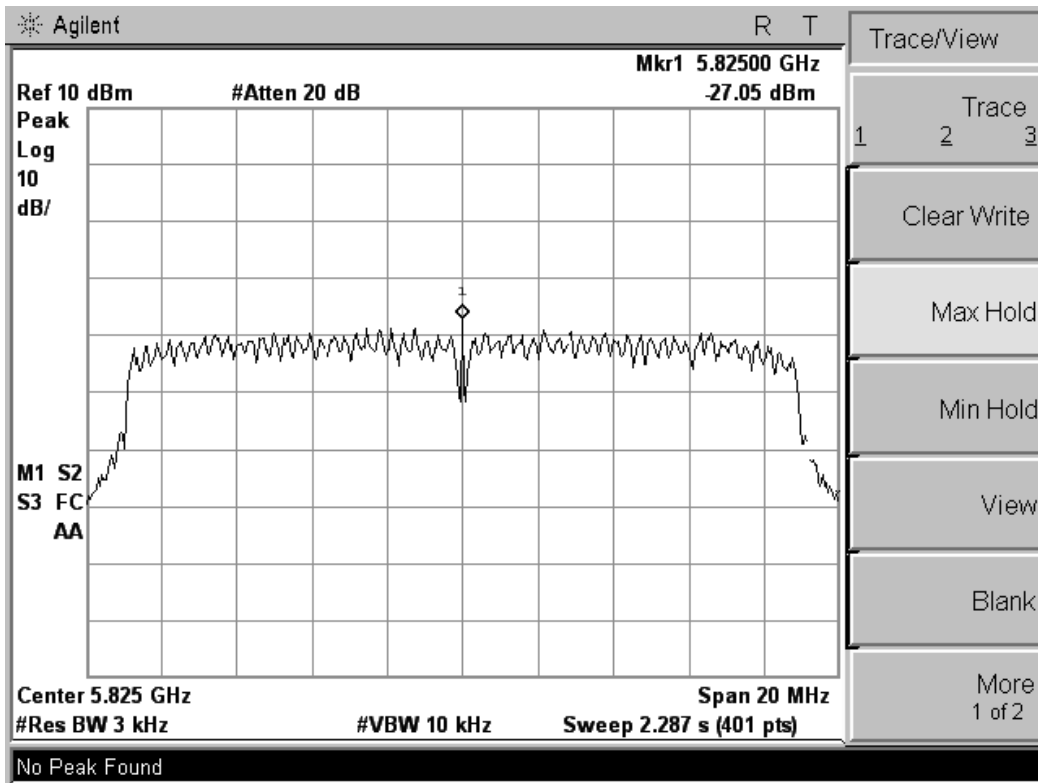

802.11n HT20 power density / port.2

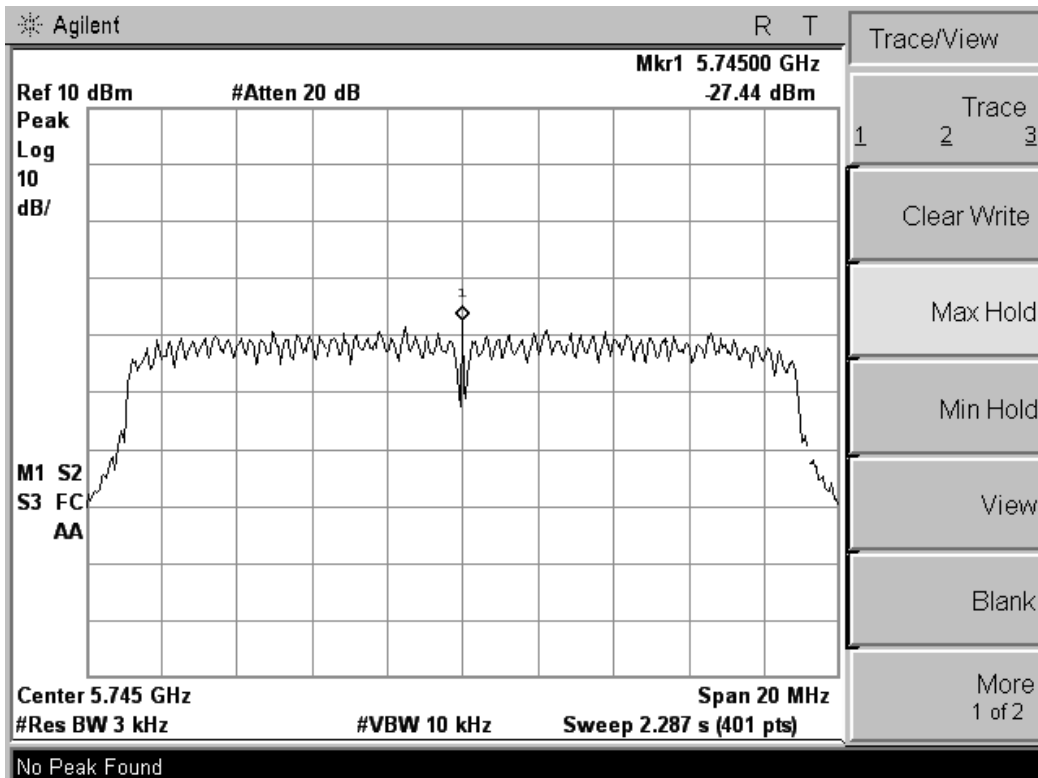

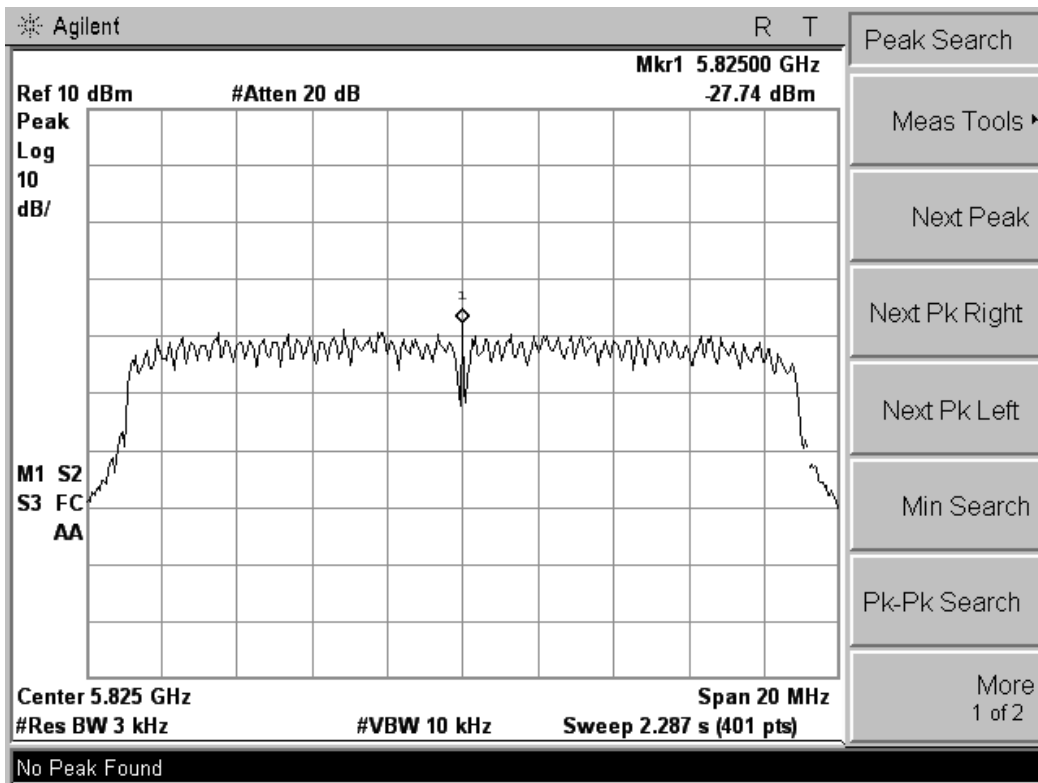
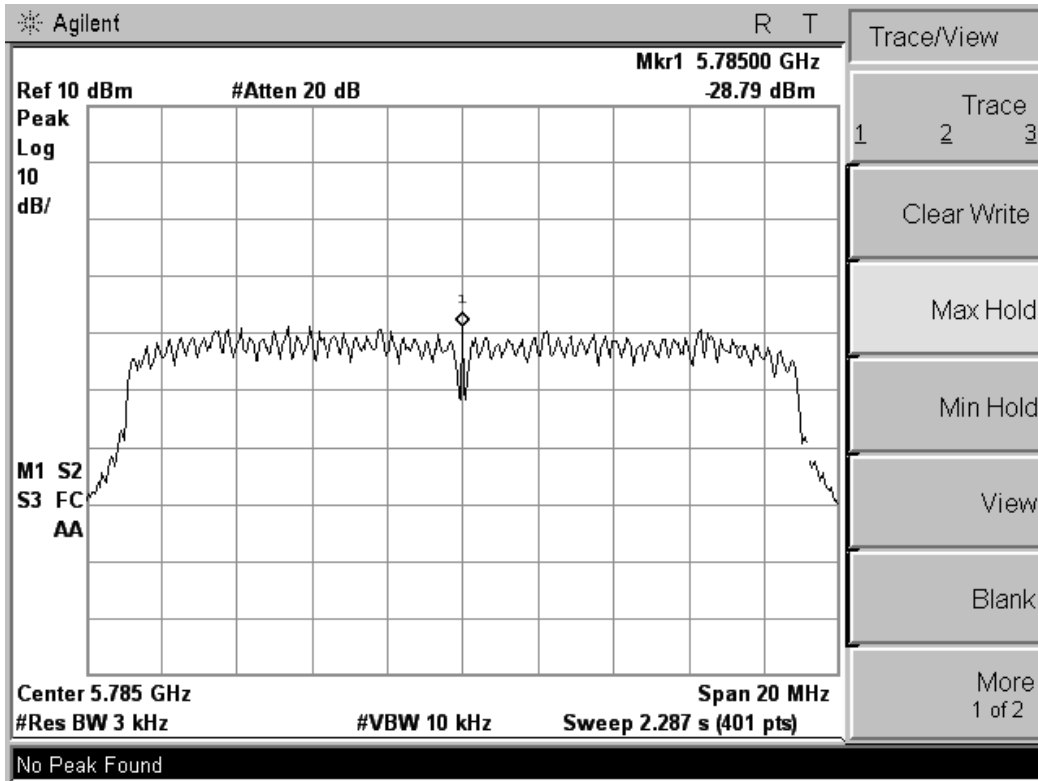

802.11n HT40 power density / port.1

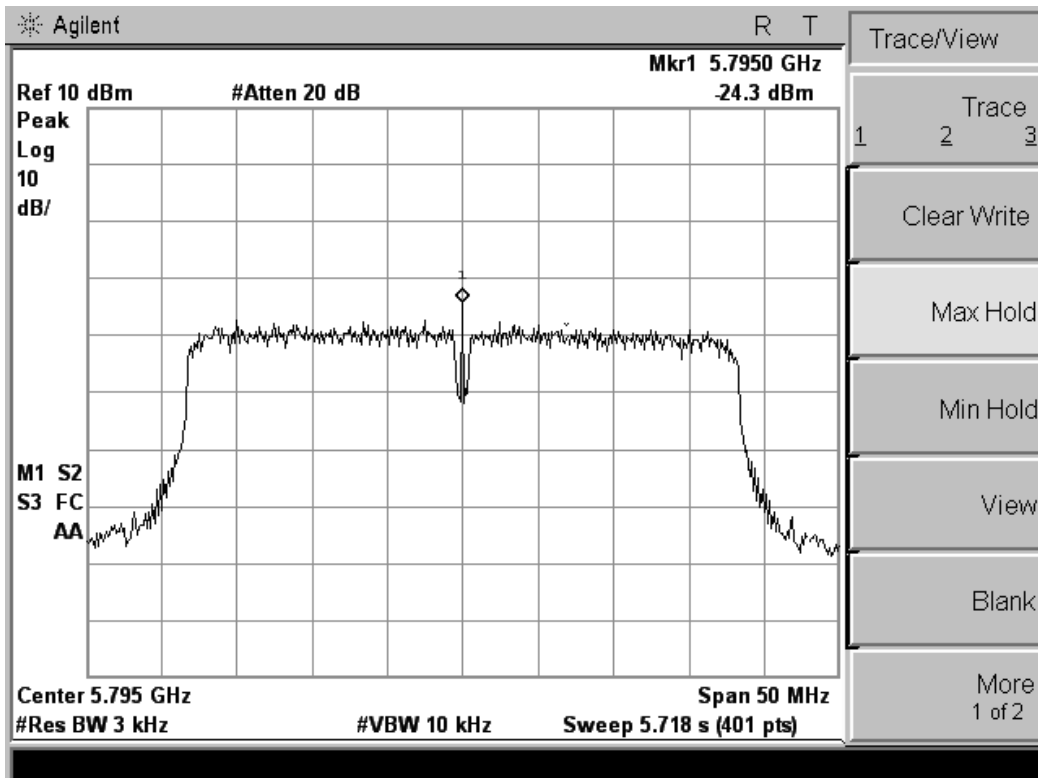
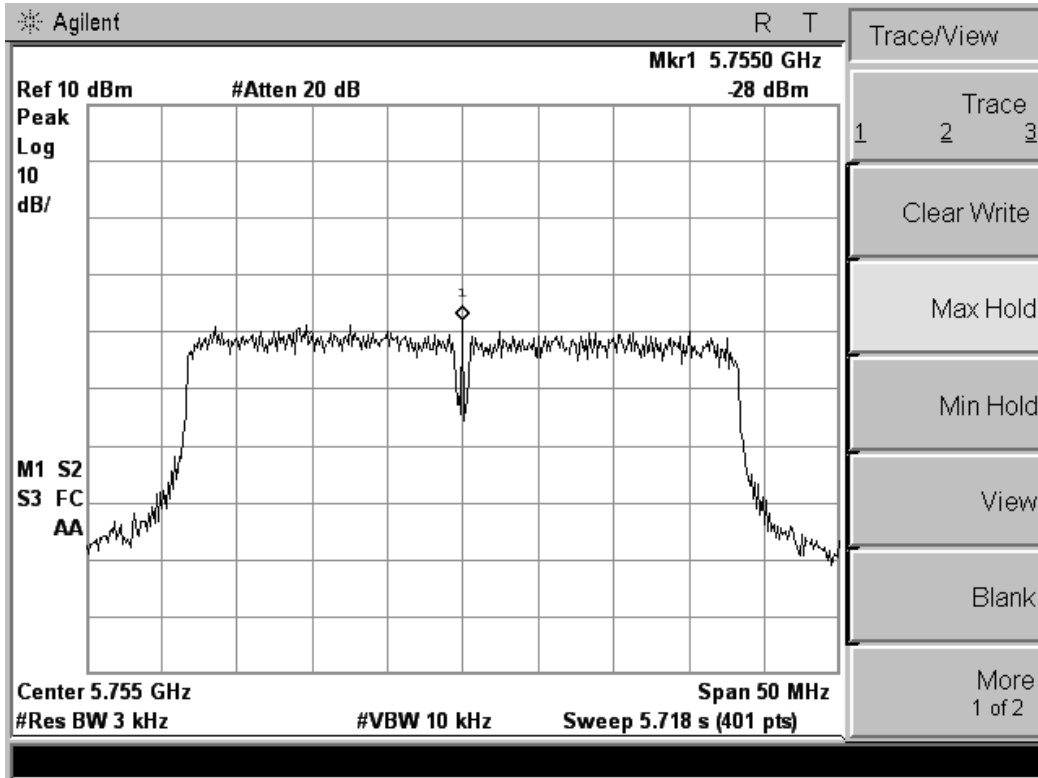

802.11n HT40 power density / port.2

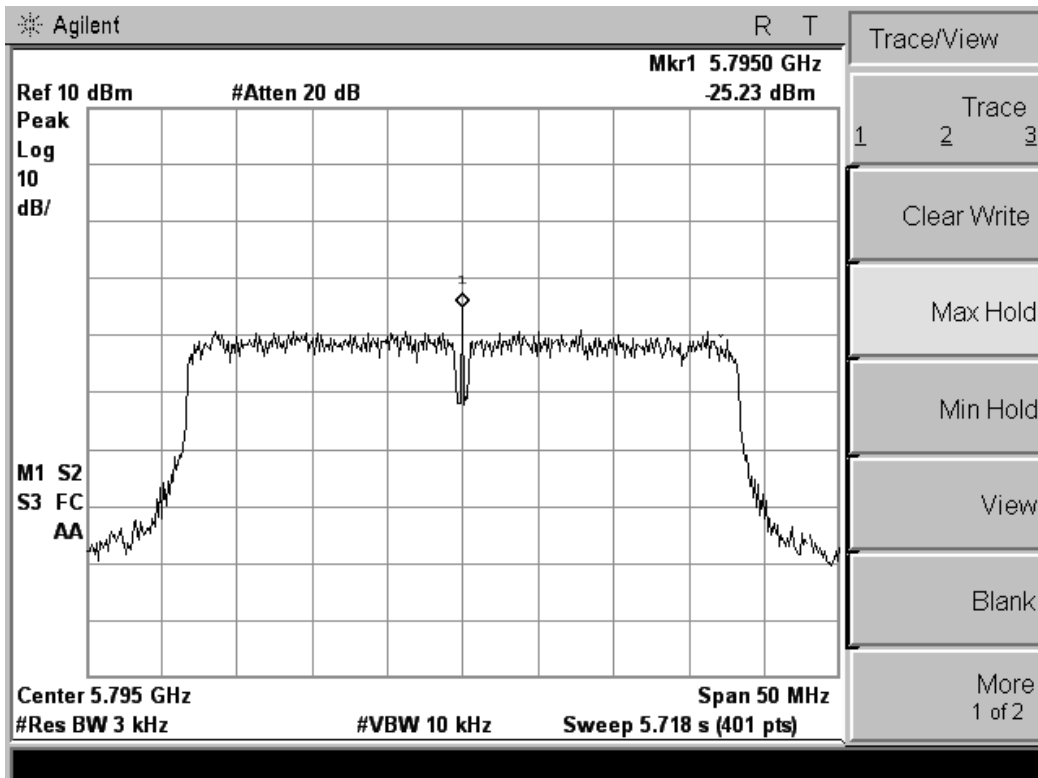
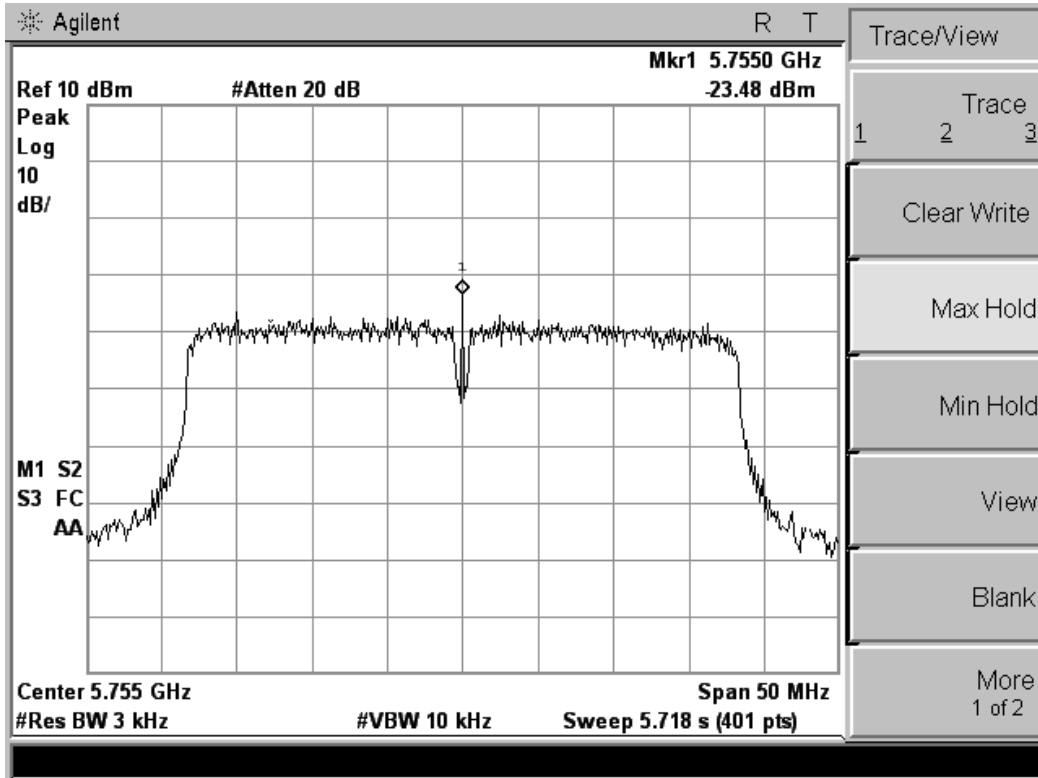

802.11a power density / port.1

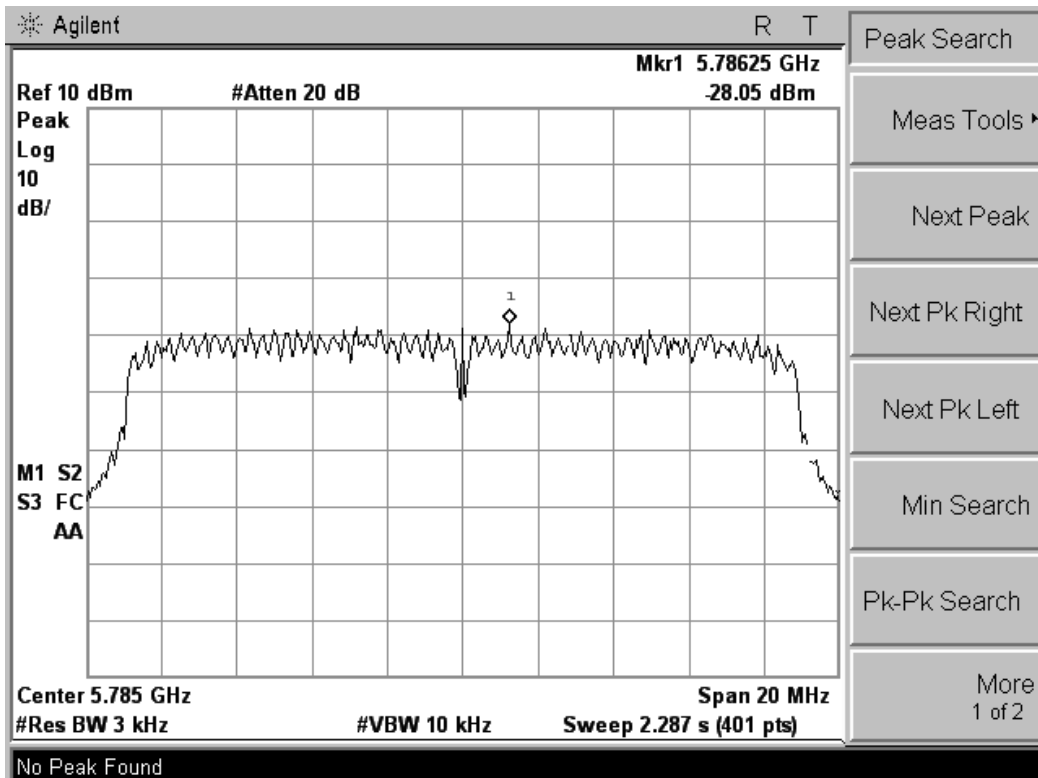
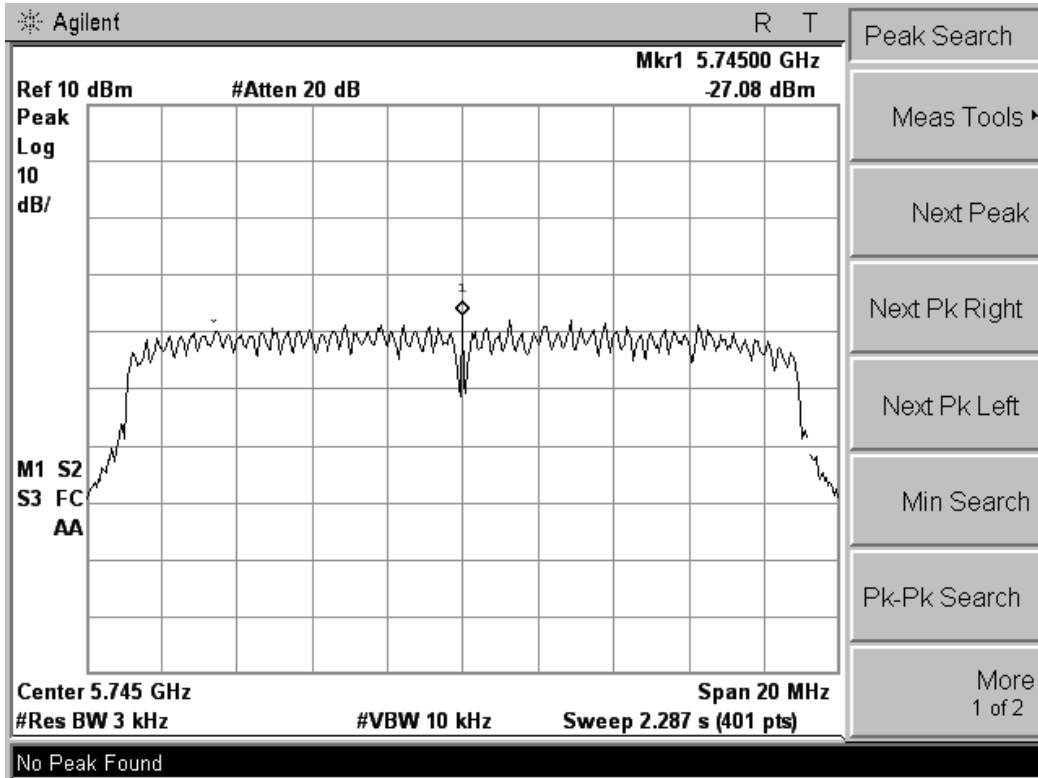

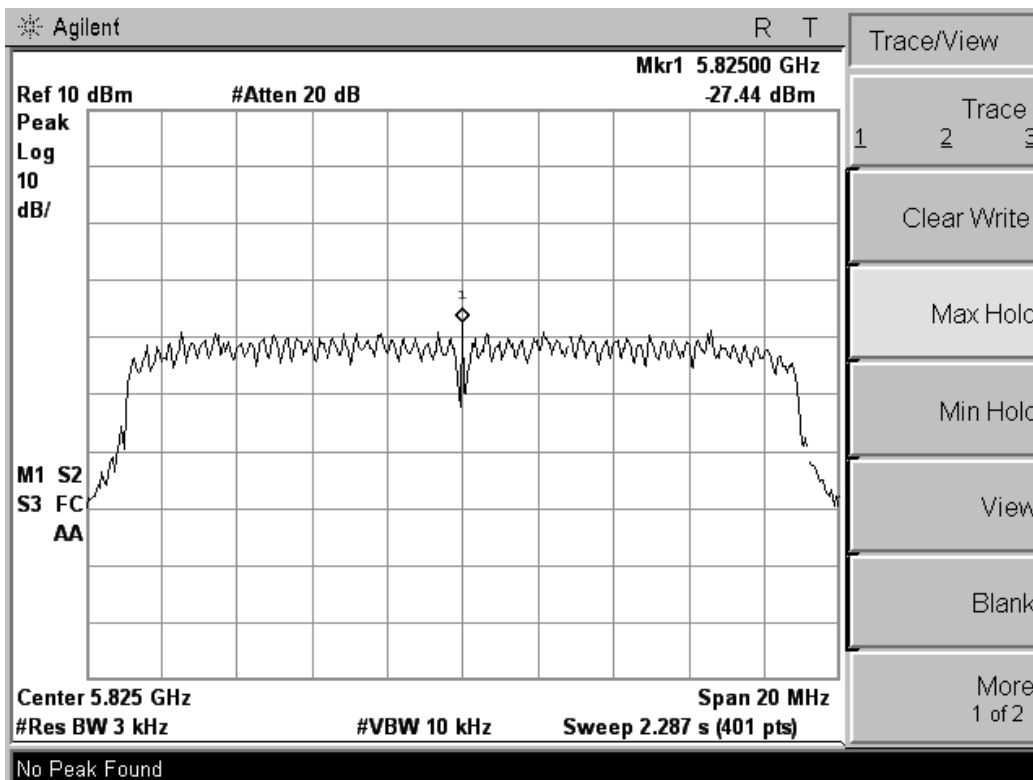

5.3. 6 dB Spectrum Bandwidth Measurement

5.3.1. Standard Applicable

According to §15.247(a)(2): For digital modulation systems, the minimum 6 dB bandwidth shall be at least 500 kHz.

5.3.2. Measuring Instruments and Setting

Please refer to section 6 of equipments list in this report. The following table is the setting of the Spectrum Analyzer.

Spectrum Parameter	Setting
Attenuation	Auto
Span Frequency	> RBW
Detector	Peak
Trace	Max Hold
Sweep Time	100ms

5.3.3. Test Procedures

1. The transmitter output (antenna port) was connected to the spectrum analyser in peak hold mode.
2. The resolution bandwidth and the video bandwidth were set according to KDB558074.
3. Measured the spectrum width with power higher than 6dB below carrier.

5.3.4. Test Setup Layout

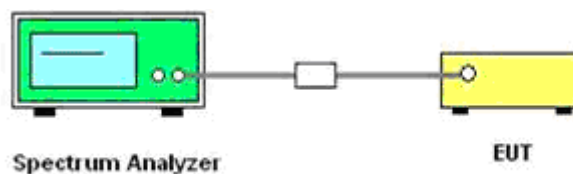

5.3.5. EUT Operation during Test

The EUT was programmed to be in continuously transmitting mode.

5.3.6. Test Result of 6dB Spectrum Bandwidth

Temperature	25°C	Humidity	60%
Test Engineer	Leo	Configurations	802.11a/b/g/n

For 2.4GHz Band:

802.11b/Port.1

Channel	Frequency	6dB Bandwidth (MHz)	Min. Limit (kHz)	Result
1	2412	12.021	500	Complies
6	2437	10.174	500	Complies
11	2462	12.054	500	Complies

802.11g/Port.1

Channel	Frequency	6dB Bandwidth (MHz)	Min. Limit (kHz)	Result
1	2412	16.312	500	Complies
6	2437	16.317	500	Complies
11	2462	16.314	500	Complies

802.11n HT20/Port.1+Port.2

Channel	Frequency	6dB Bandwidth (MHz)	Min. Limit (kHz)	Result
1	2412	16.902	500	Complies
6	2437	16.564	500	Complies
11	2462	16.889	500	Complies

802.11n HT40/Port.1+Port.2

Channel	Frequency	6dB Bandwidth (MHz)	Min. Limit (kHz)	Result
3	2422	35.697	500	Complies
6	2437	35.601	500	Complies
9	2452	35.496	500	Complies

For 5GHz Band:

802.11n HT20/Port.1+Port.2

Channel	Frequency	6dB Bandwidth (MHz)	Min. Limit (kHz)	Result
149	5745	16.702	500	Complies
157	5785	16.781	500	Complies
165	5825	16.813	500	Complies

802.11n HT40/Port.1+Port.2

Channel	Frequency	6dB Bandwidth (MHz)	Min. Limit (kHz)	Result
151	5755	36.305	500	Complies
159	5795	36.328	500	Complies

802.11a/Port.1

Channel	Frequency	6dB Bandwidth (MHz)	Min. Limit (kHz)	Result
149	5745	16.660	500	Complies
157	5785	16.941	500	Complies
165	5825	16.703	500	Complies

Test Plots of 2.4GHz Band
802.11b channel, 6dB bandwidth / port.1

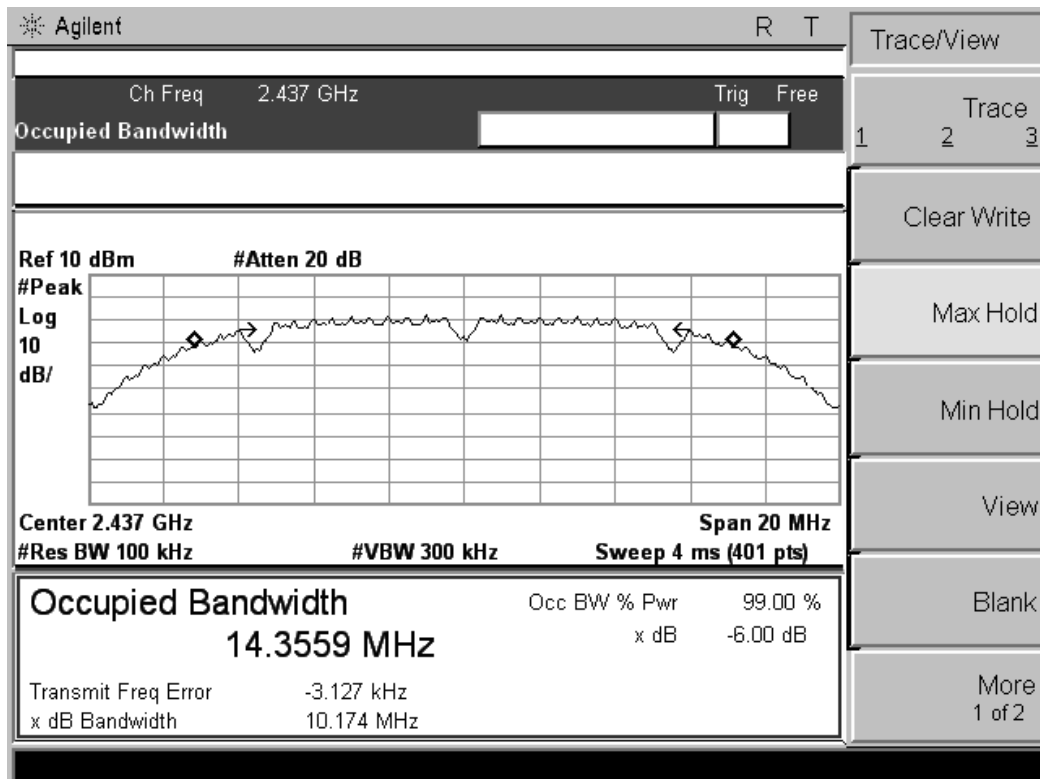
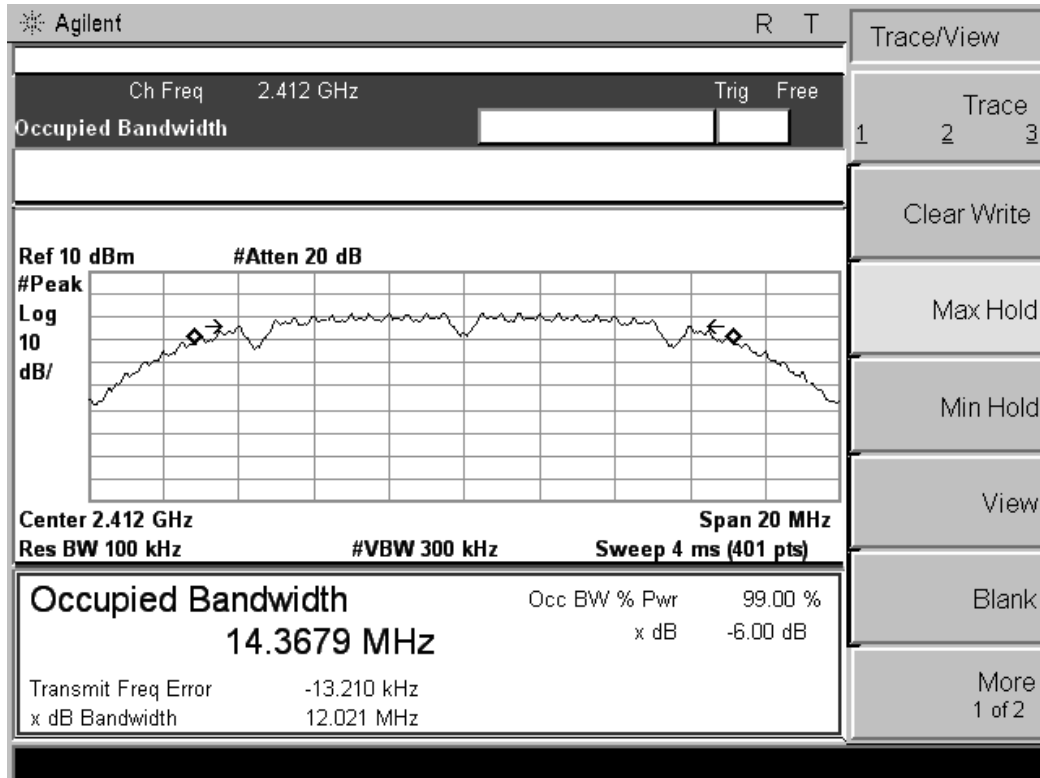

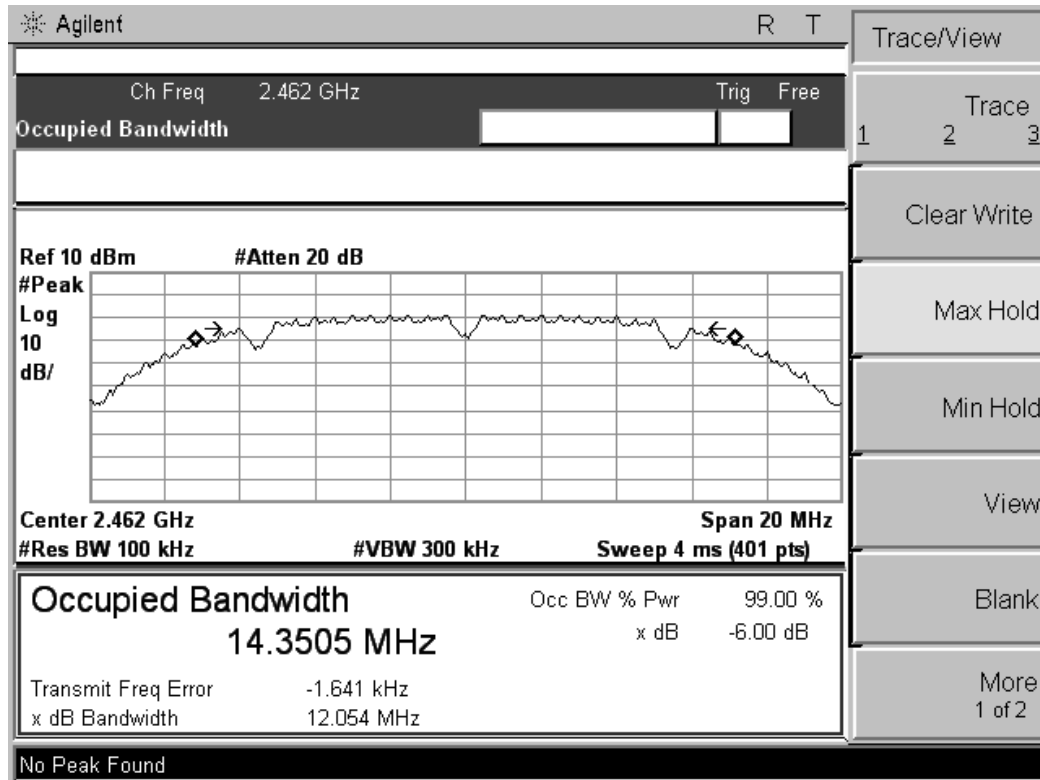

802.11g channel, 6dB bandwidth / port.1

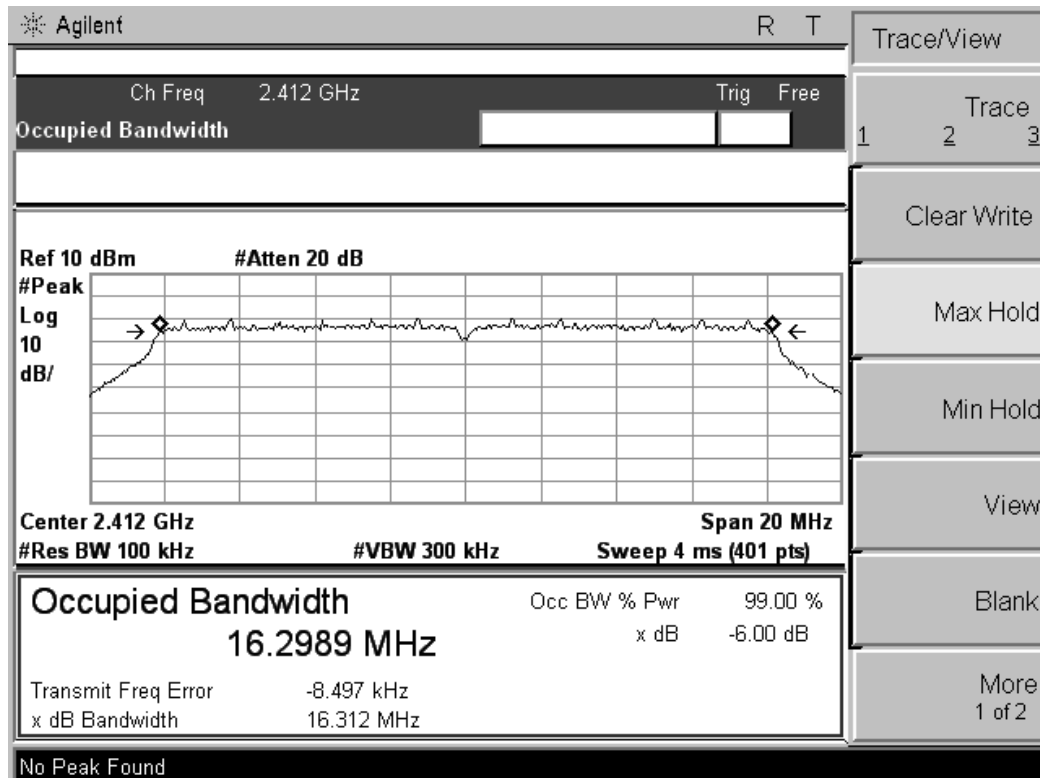

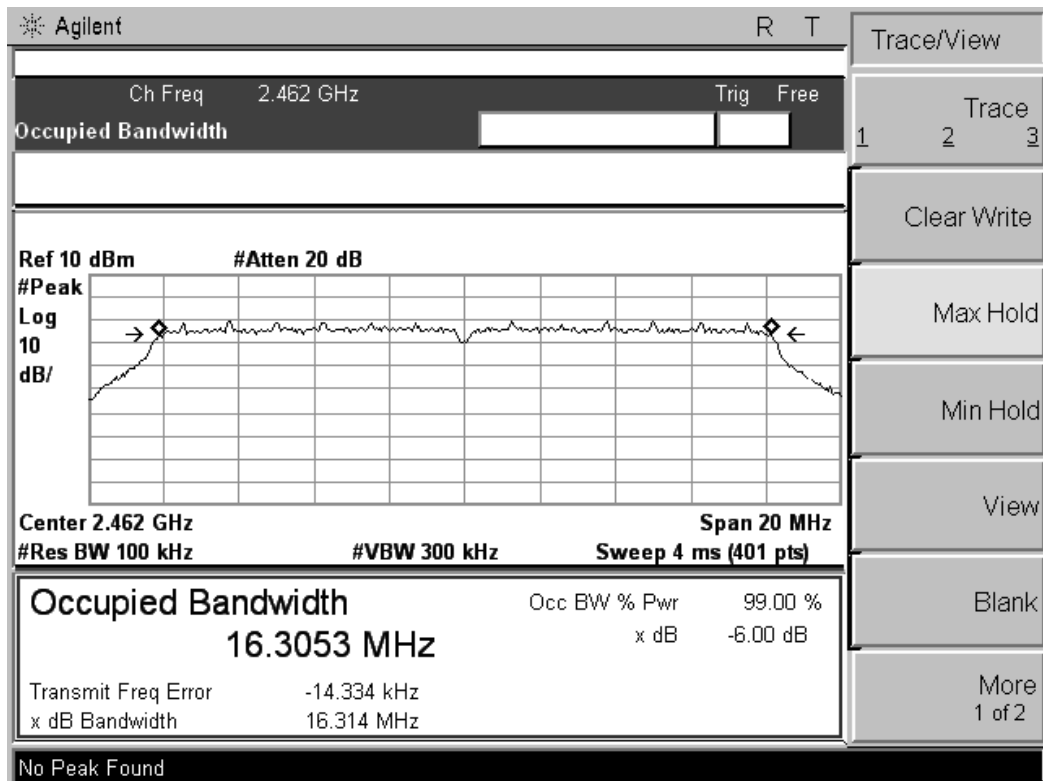
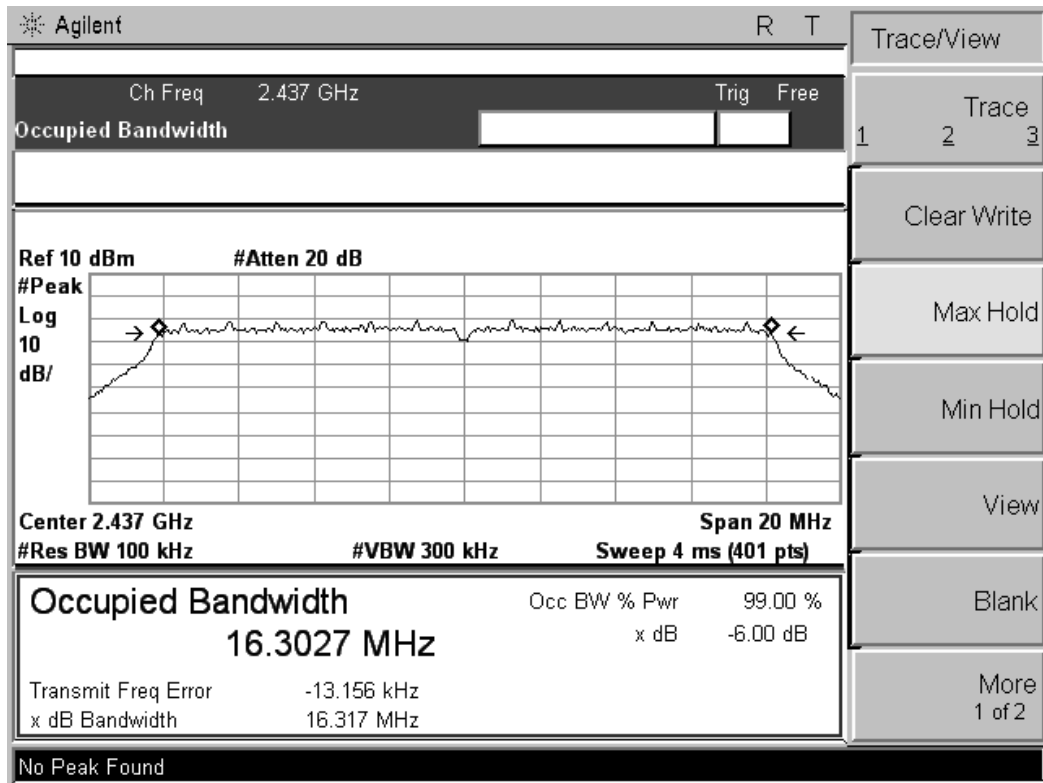

802.11n HT20 channel, 6dB bandwidth / port.1+ port.2

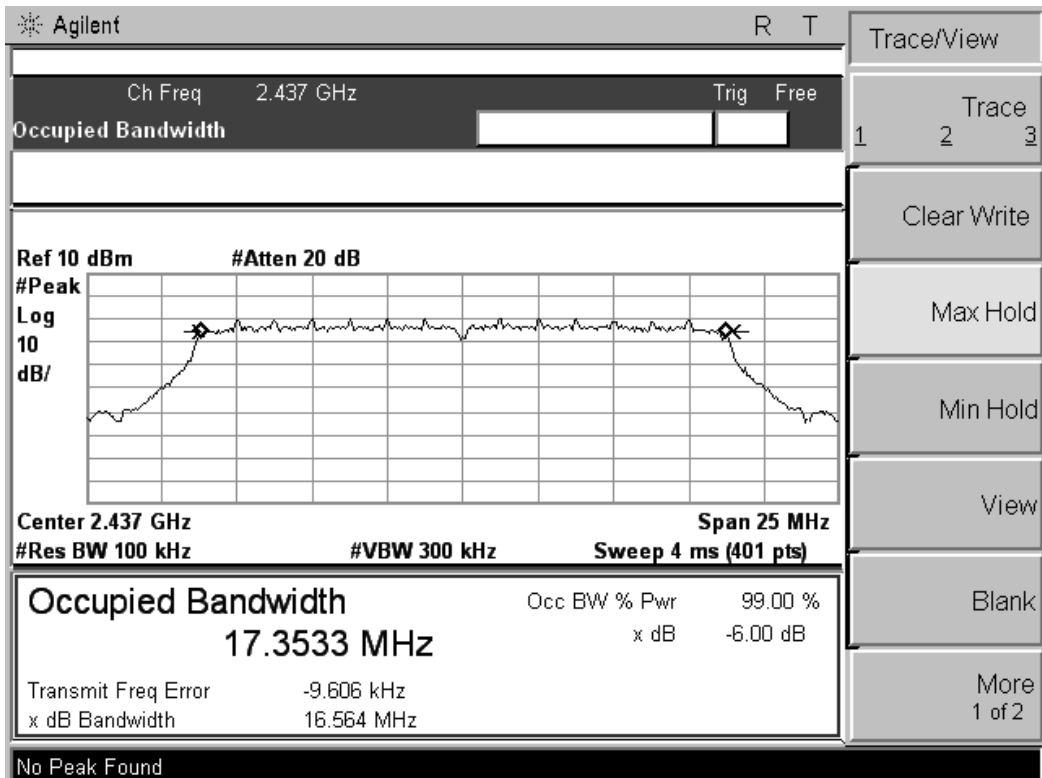
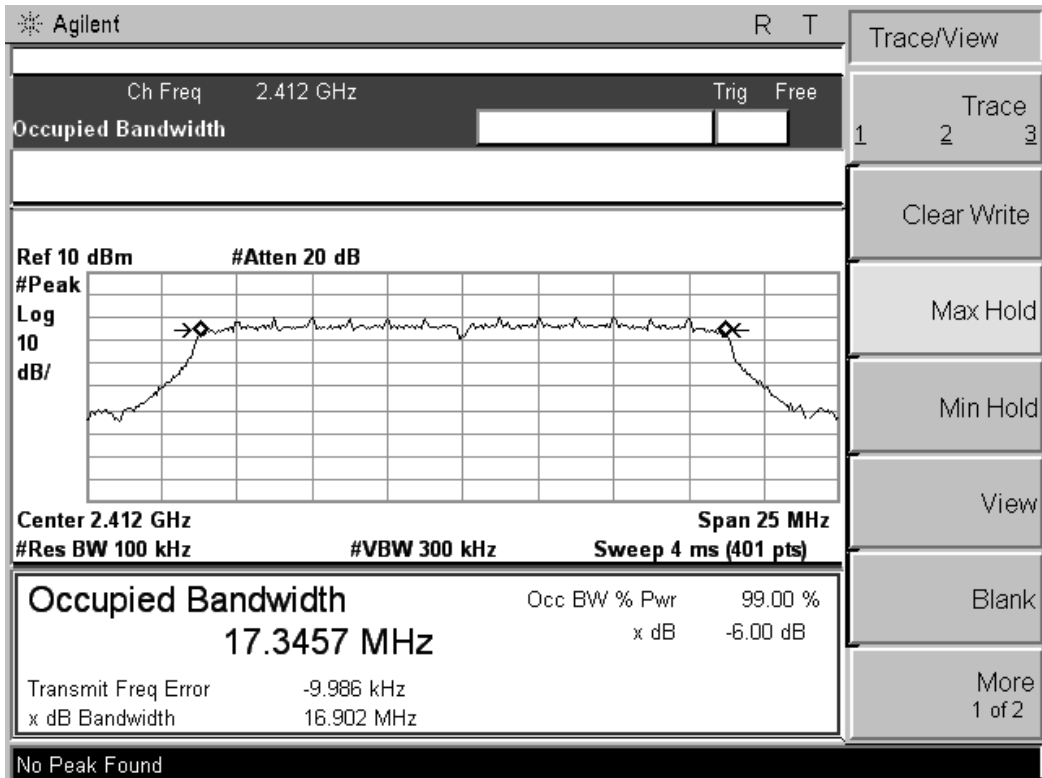

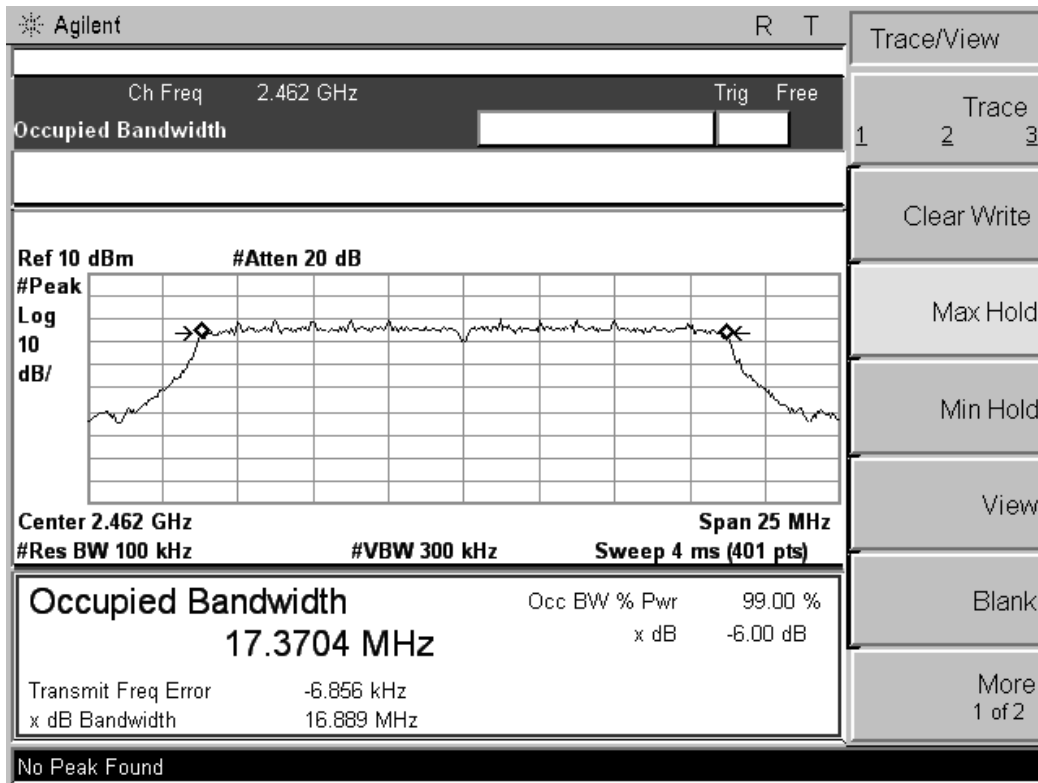

802.11n HT40 channel, 6dB bandwidth / port.1+ port.2

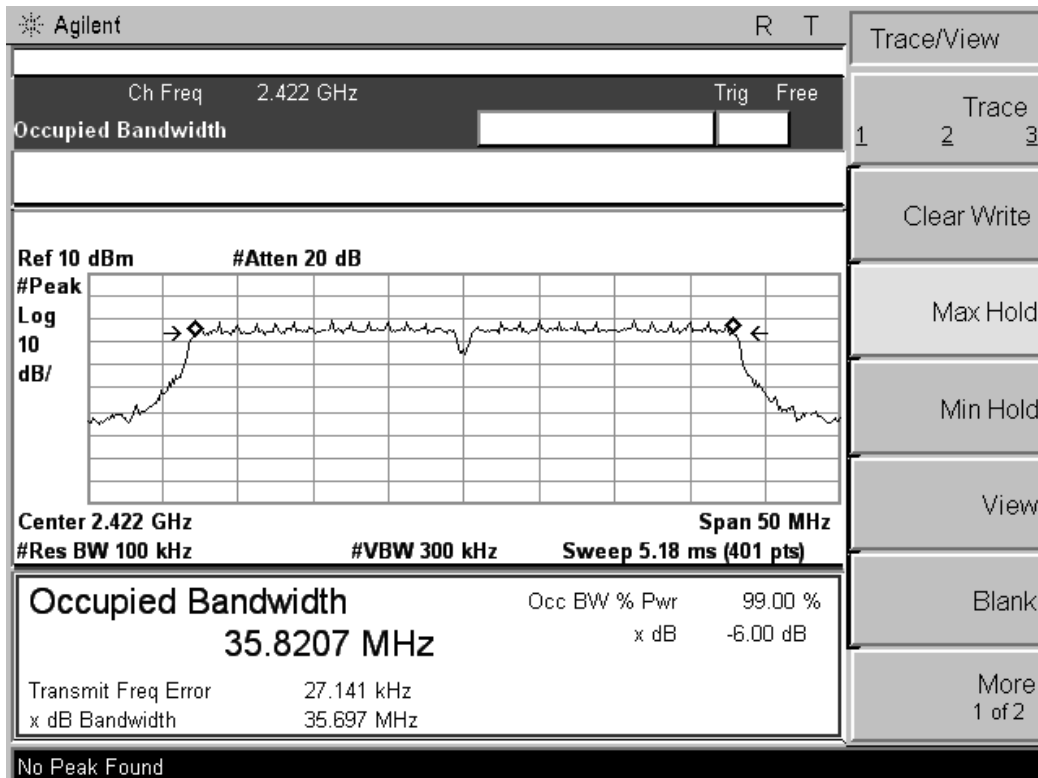

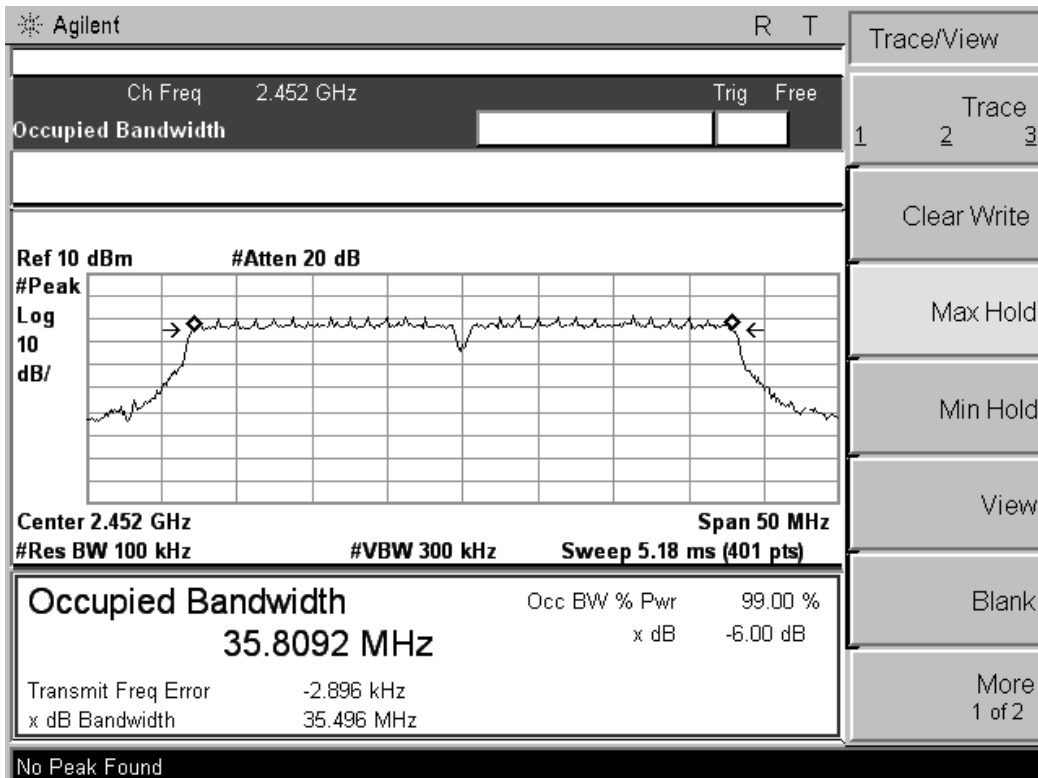
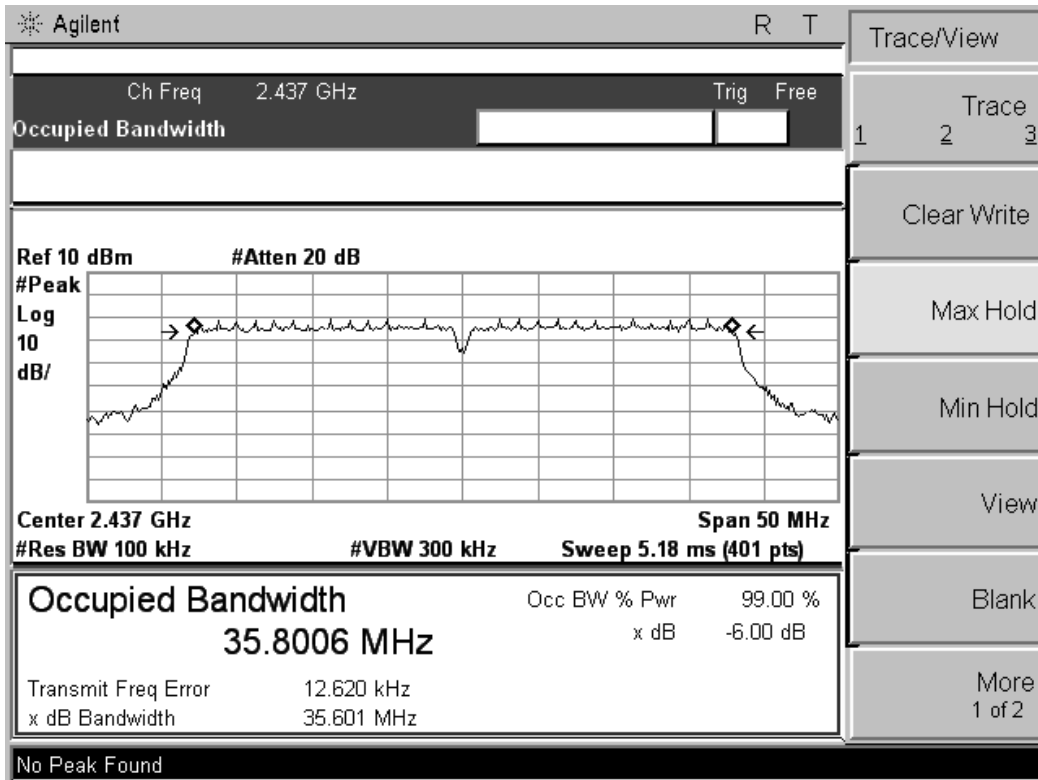

Test Plots of 5GHz Band

802.11n HT20 channel, 6dB bandwidth / port.1+ port.2

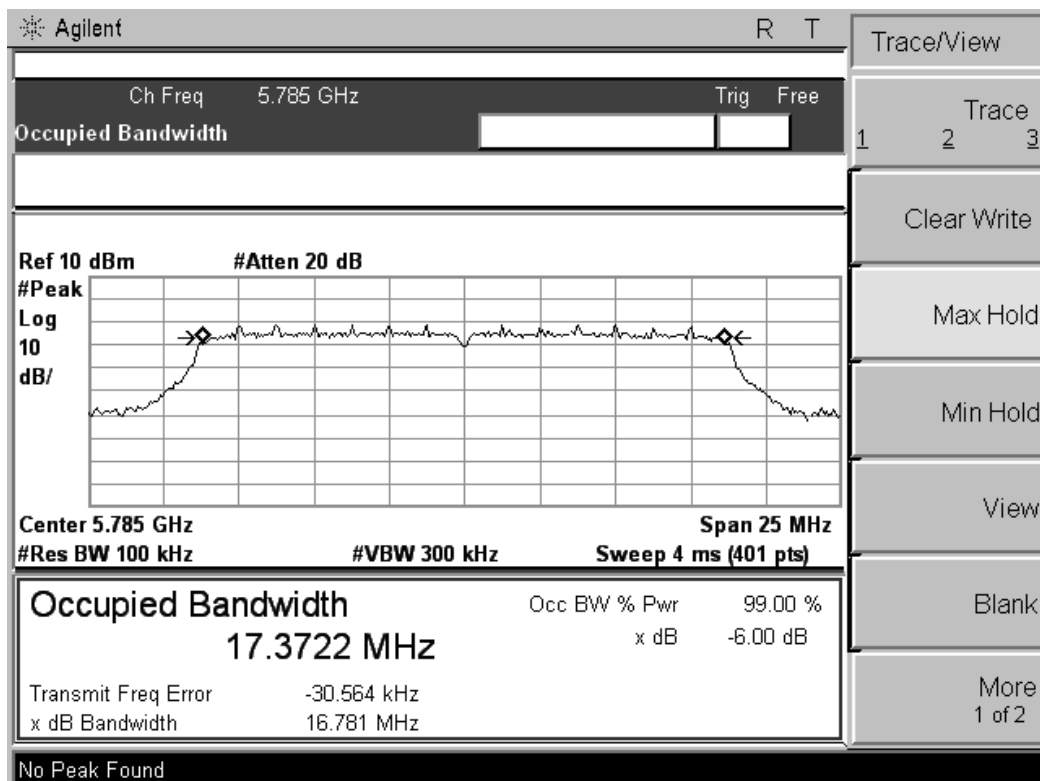
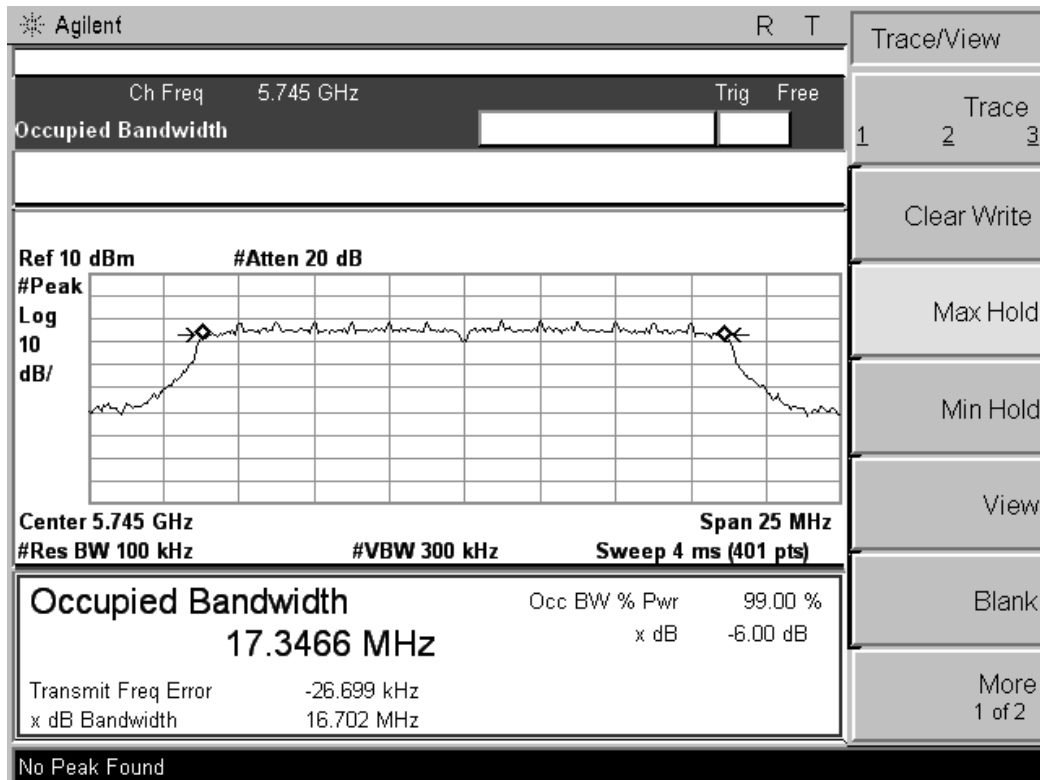

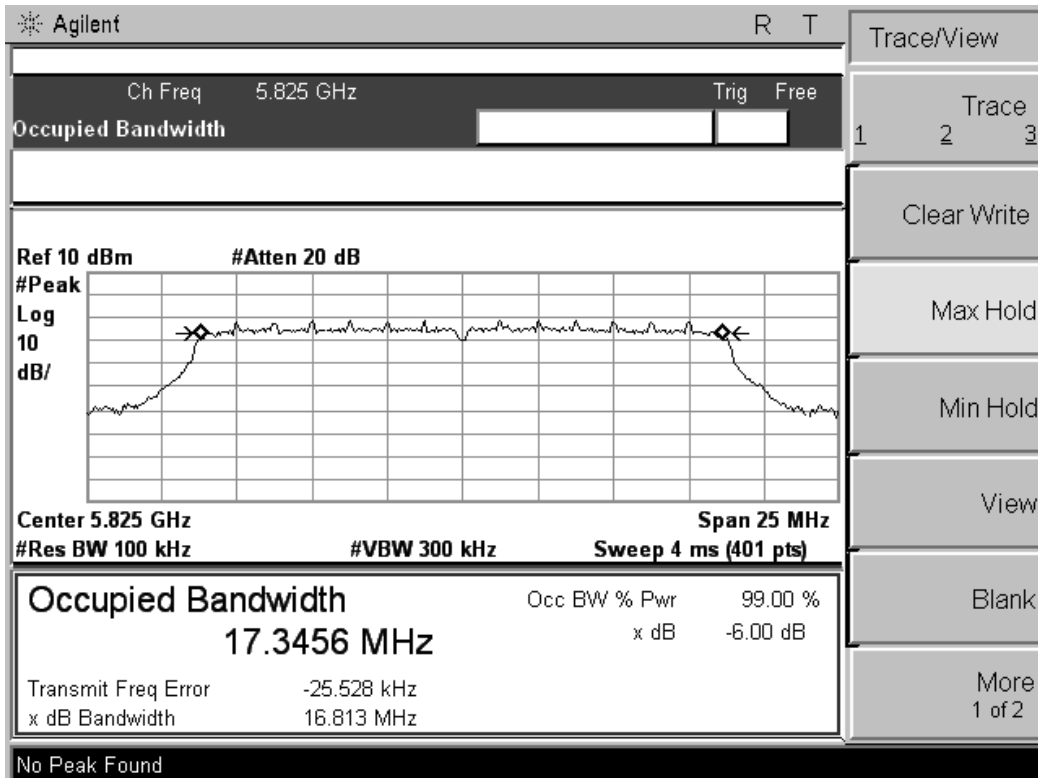

802.11n HT40 channel, 6dB bandwidth / port.1+ port.2

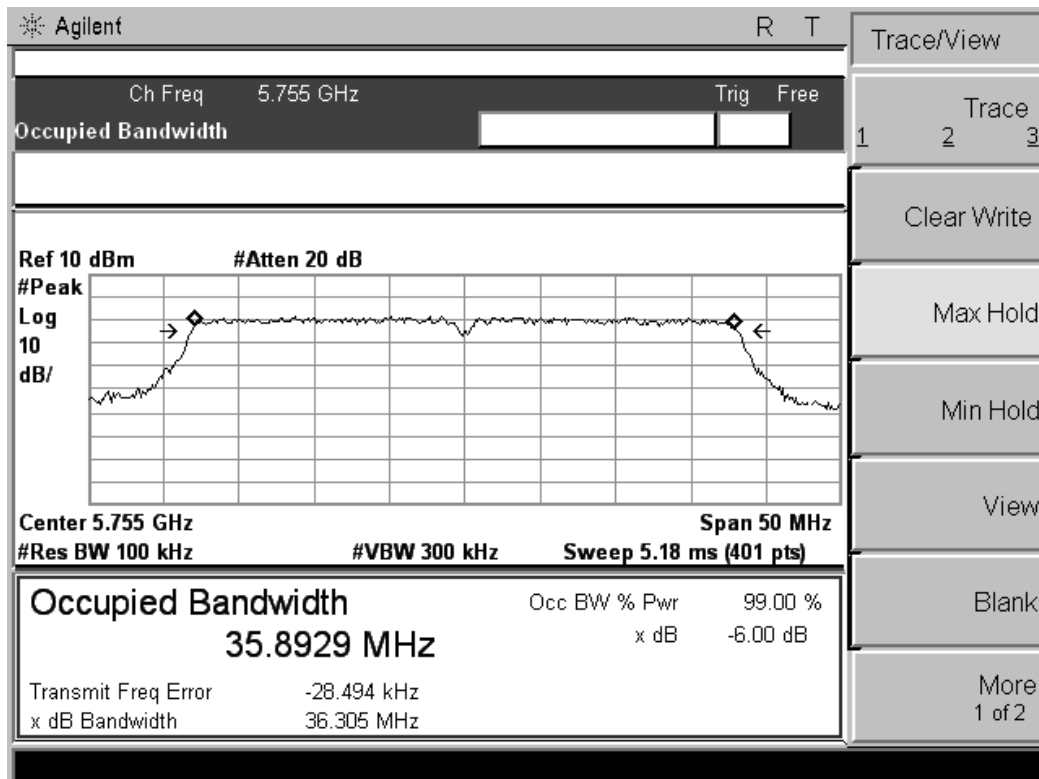

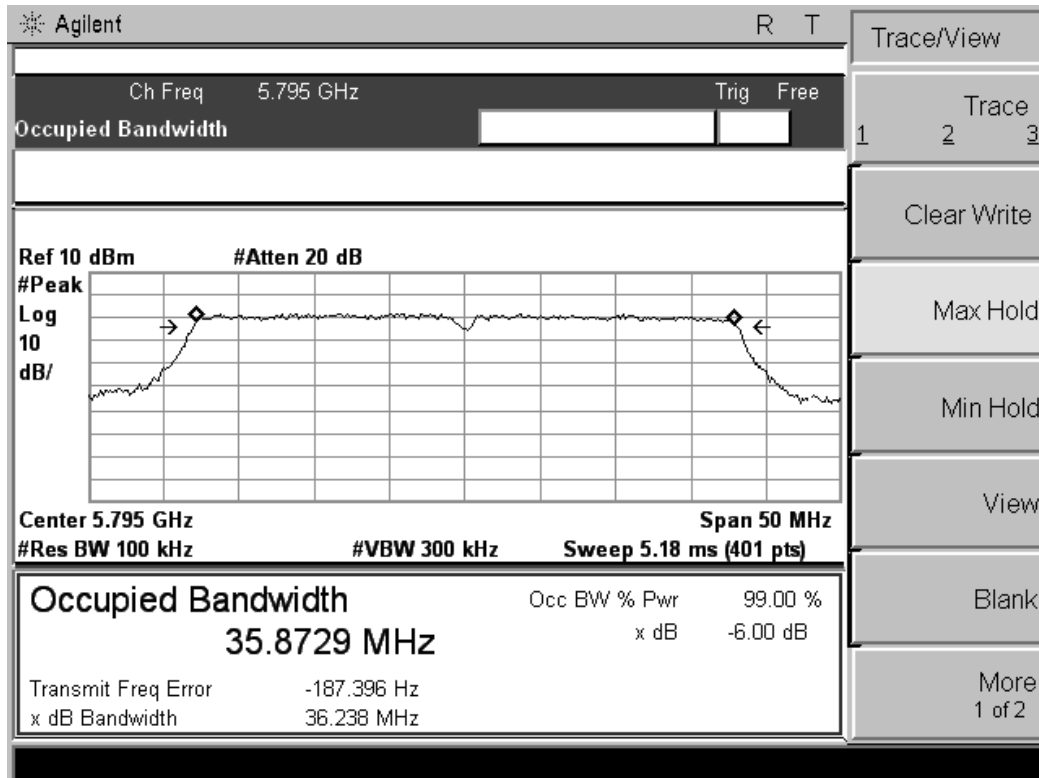

802.11a channel, 6dB bandwidth / port.1

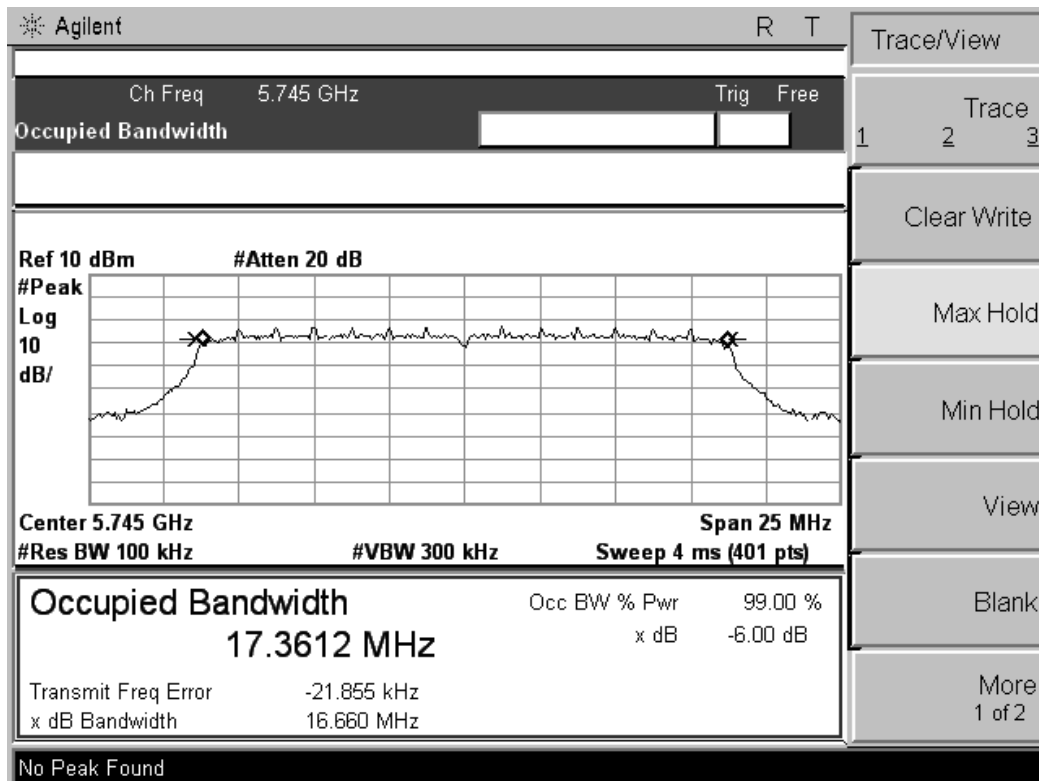

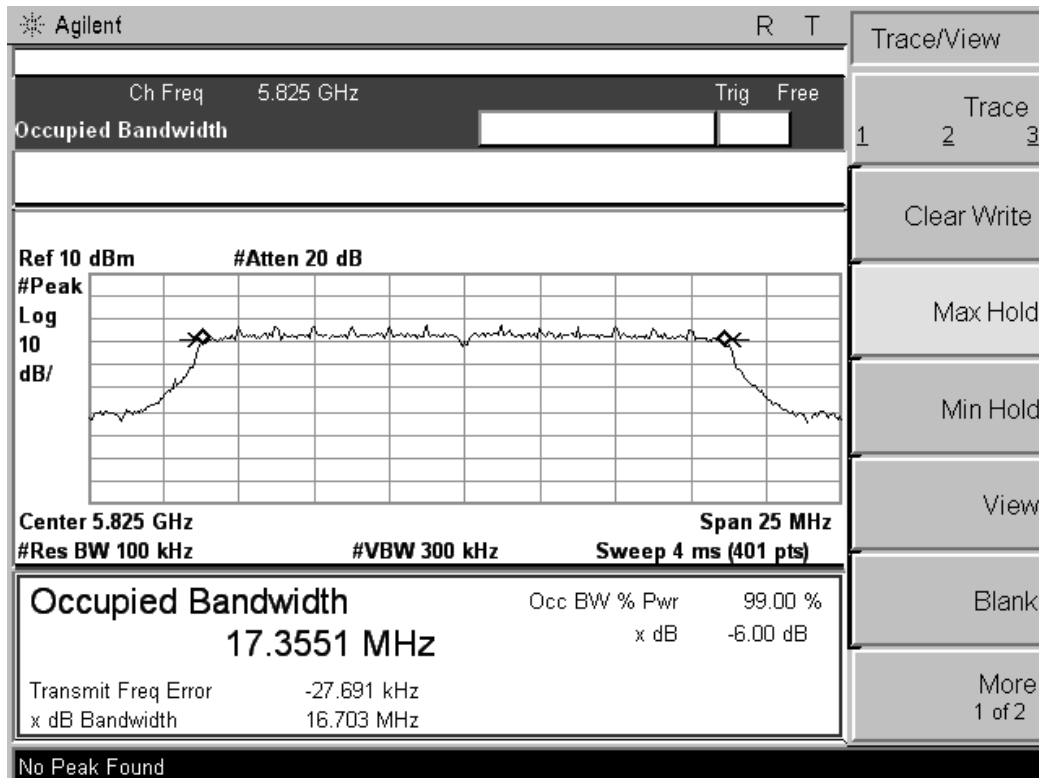
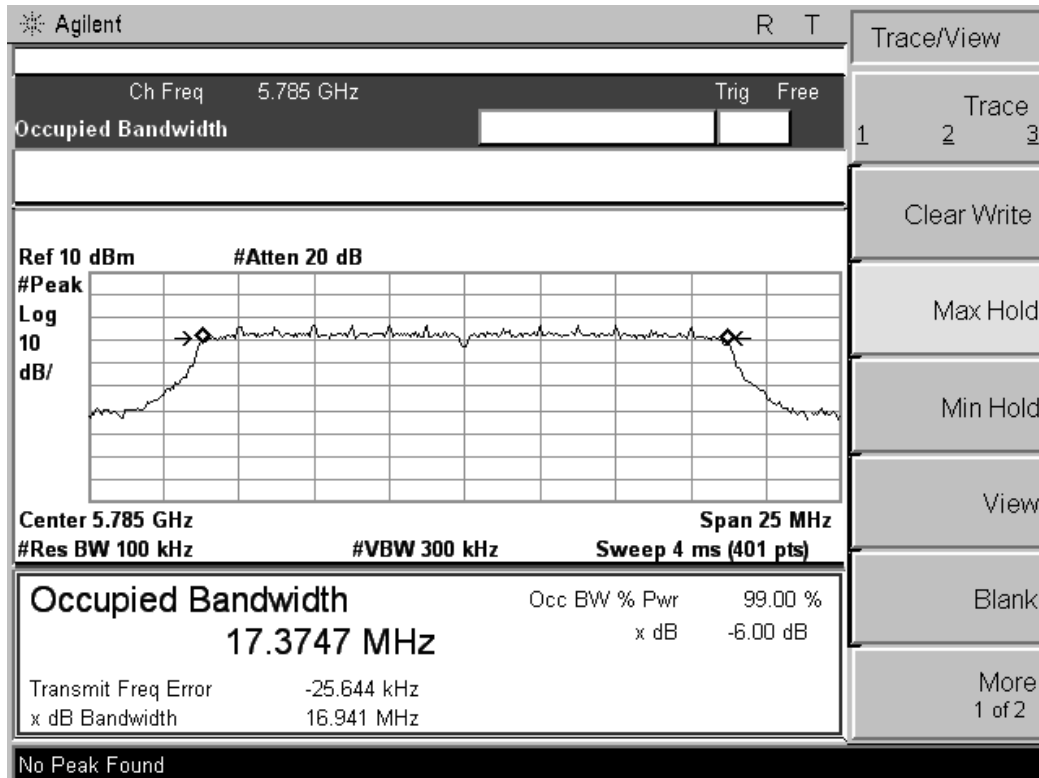

5.4. Occupied Bandwidth

5.4.1. Standard Applicable

According to §15.247(a): Operation under the provisions of this section is limited to frequency hopping and digitally modulated intentional radiators that comply with the following provisions:

For systems using digital modulation techniques, the EUT may operate in the 902-928 MHz, 2400-2483.5 MHz and 5725-5850 MHz bands. The minimum 6dB bandwidth shall be at least 500 kHz.

5.4.2. Measuring Instruments and Setting

Please refer to section 6 of equipments list in this report. The following table is the setting of the Spectrum Analyzer.

Spectrum Parameter	Setting
Attenuation	Auto
Span Frequency	> RBW
RBW	1% to 3% of the band
VBW	3 times the RBW
Detector	Peak
Trace	Max Hold
Sweep Time	100ms

5

5.4.3. Test Procedures

The transmitter output is connected to the spectrum analyzer. The RBW is set to 1% to 3% of the bandwidth. The VBW is set to 3 times the RBW. The sweep time is coupled. The spectrum analyzer internal bandwidth measurement function is utilized.

5.4.4. Test Setup Layout

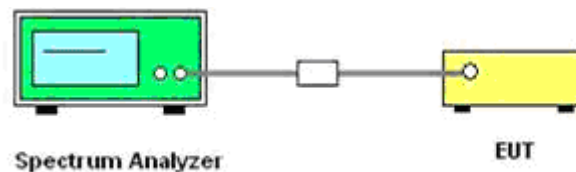

5.4.5. EUT Operation during Test

The EUT was programmed to be in continuously transmitting mode.

5.4.6. Test Result of 99% Occupied Bandwidth.

Temperature	25°C	Humidity	60%
Test Engineer	Leo	Configurations	802.11b/g

For 2.4GHz Band:

802.11b/Port.1

Channel	Frequency (MHz)	99% OBW (MHz)
1	2412	14.359
6	2437	14.364
11	2462	14.359

802.11g/Port.1

Channel	Frequency (MHz)	99% OBW (MHz)
1	2412	16.309
6	2437	16.301
11	2462	16.307

802.11n HT20/Port.1+Port.2

Channel	Frequency (MHz)	99% OBW (MHz)
1	2412	17.360
6	2437	17.386
11	2462	17.363

802.11n HT40/Port.1+Port.2

Channel	Frequency (MHz)	99% OBW (MHz)
3	2422	35.820
6	2437	35.802
9	2452	35.801

For 5GHz Band:

802.11n HT20/Port.1+Port.2

Channel	Frequency (MHz)	99% OBW (MHz)
149	5745	17.348
157	5785	17.365
165	5825	17.350

802.11n HT40/Port.1+Port.2

Channel	Frequency (MHz)	99% OBW (MHz)
151	5755	35.893
159	5795	35.770

802.11a/Port.1

Channel	Frequency (MHz)	99% OBW (MHz)
149	5745	17.355
157	5785	17.387
165	5825	17.350

Test Plots of 2.4GHz Band

802.11b channel, 99% Occupied Bandwidth / port.1

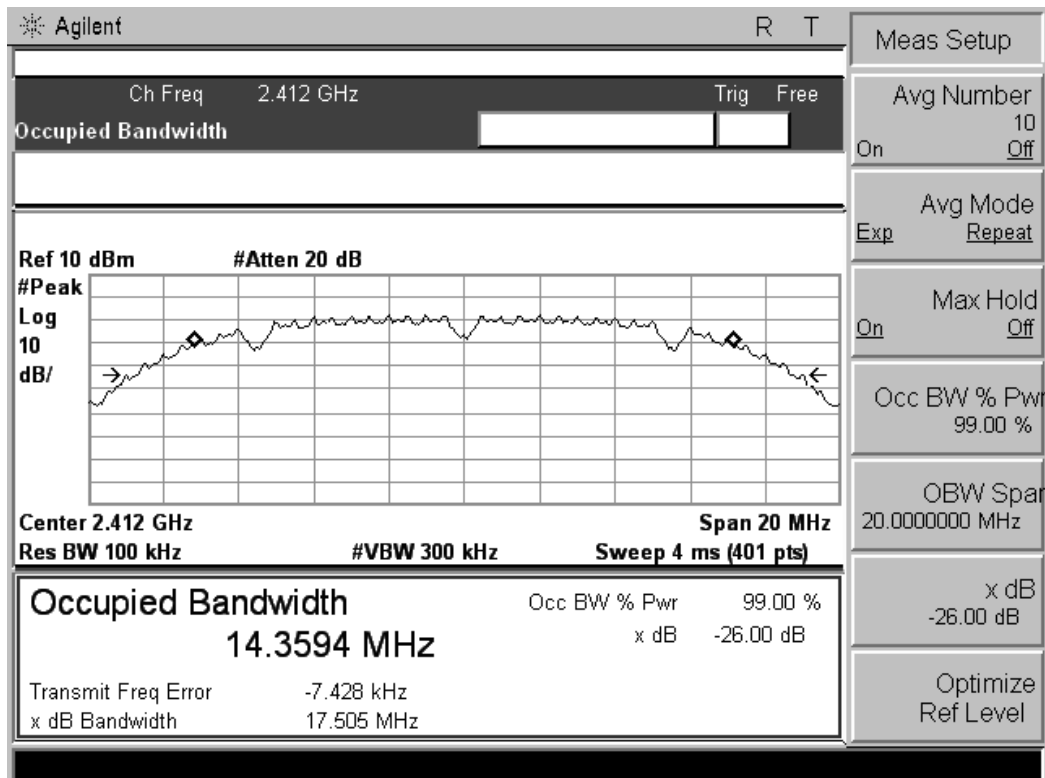

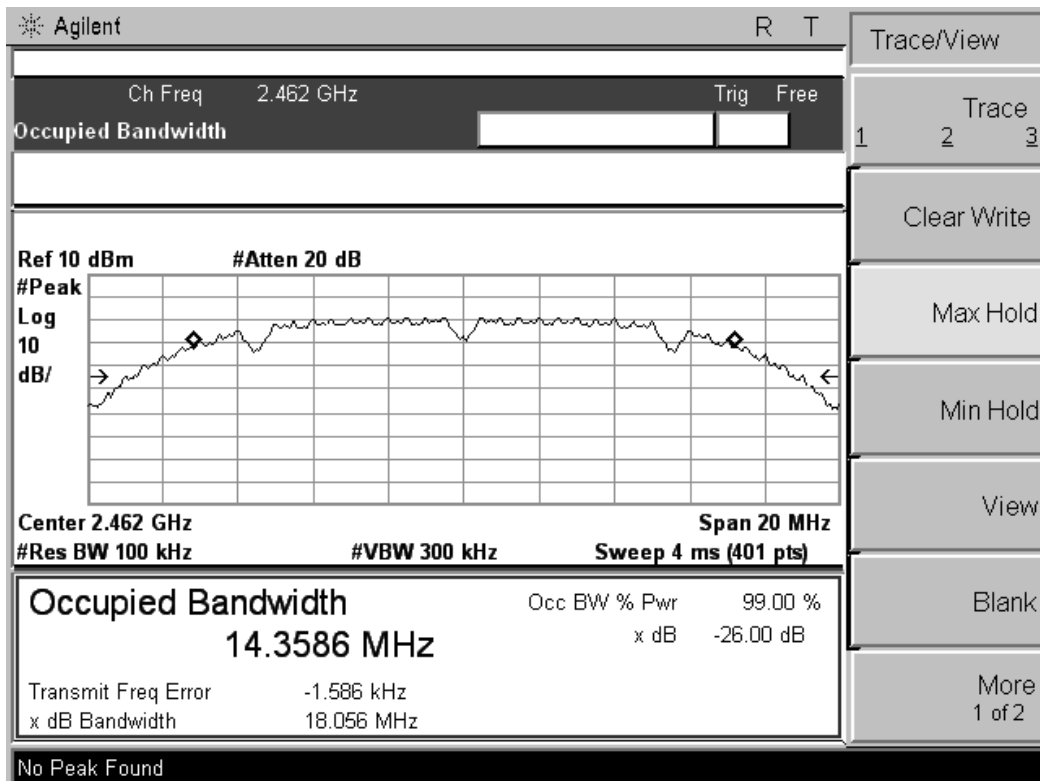
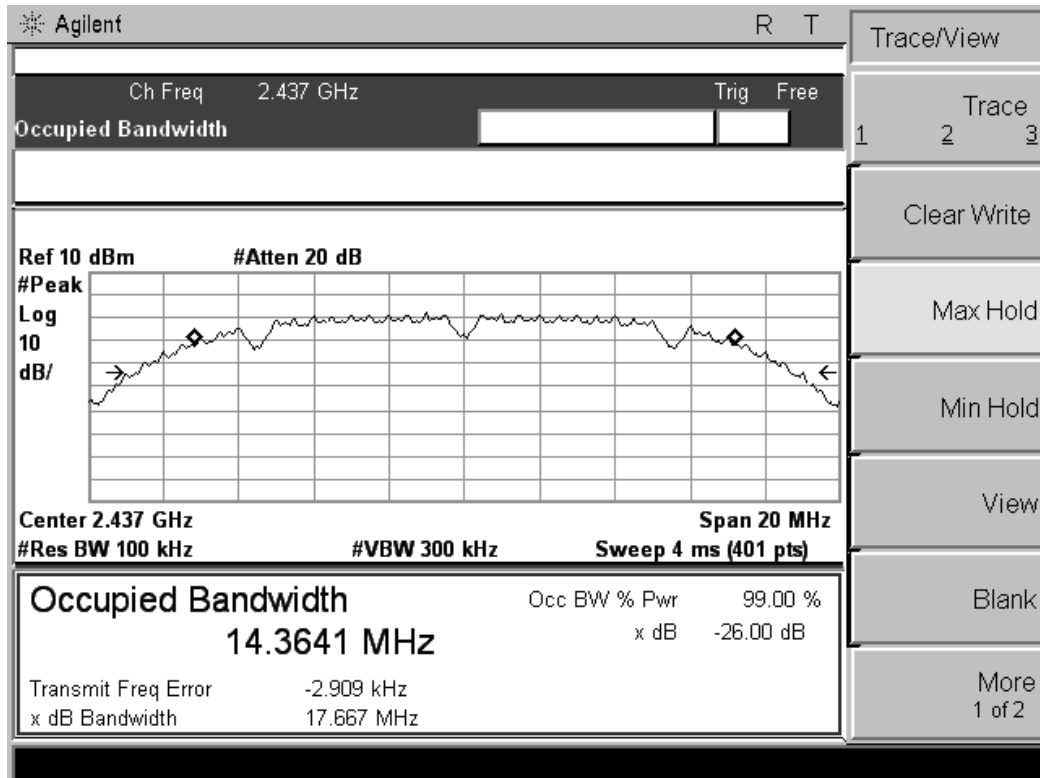

802.11g channel, 99% Occupied Bandwidth / port.1

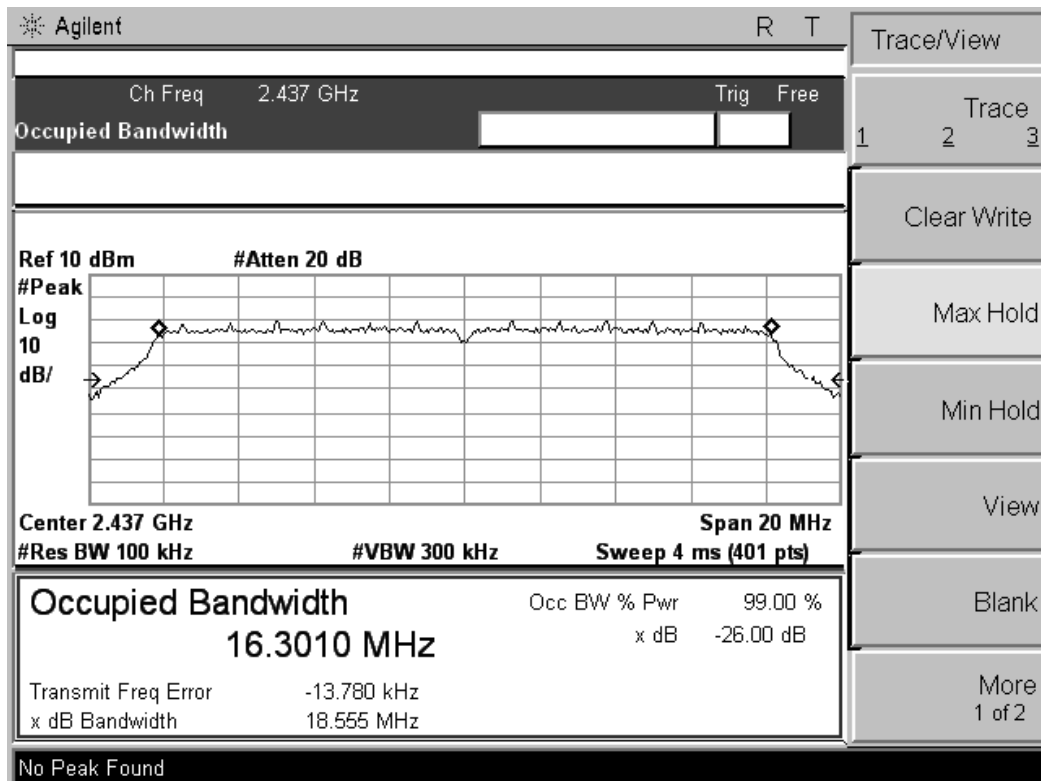
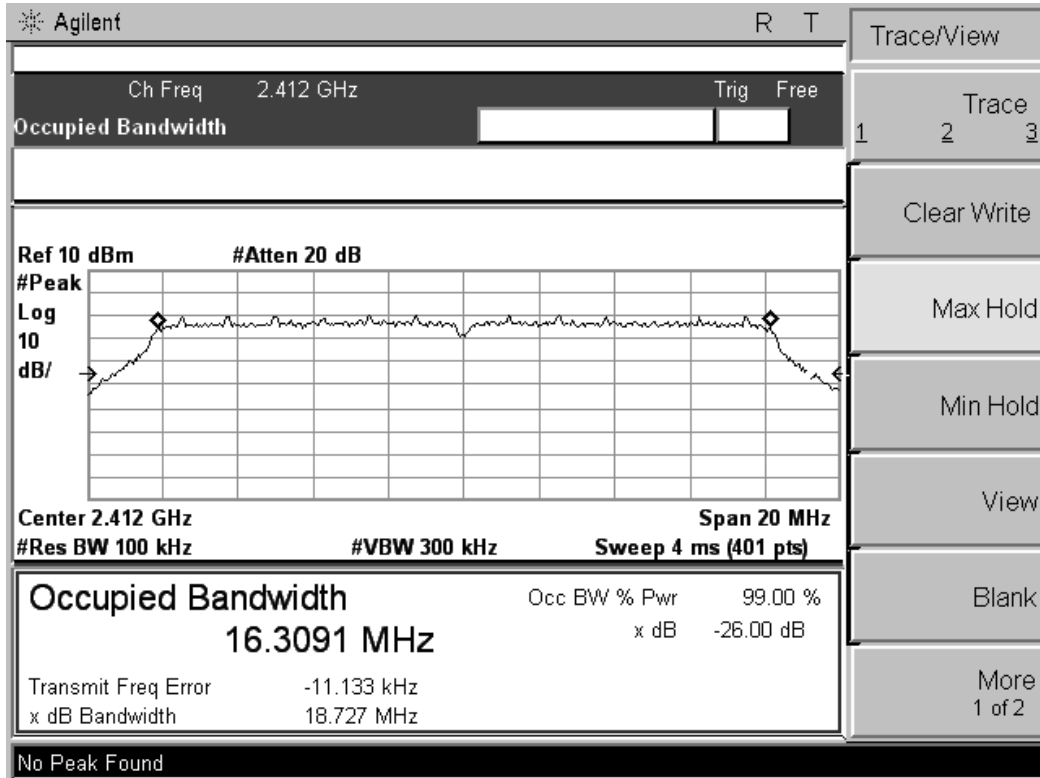

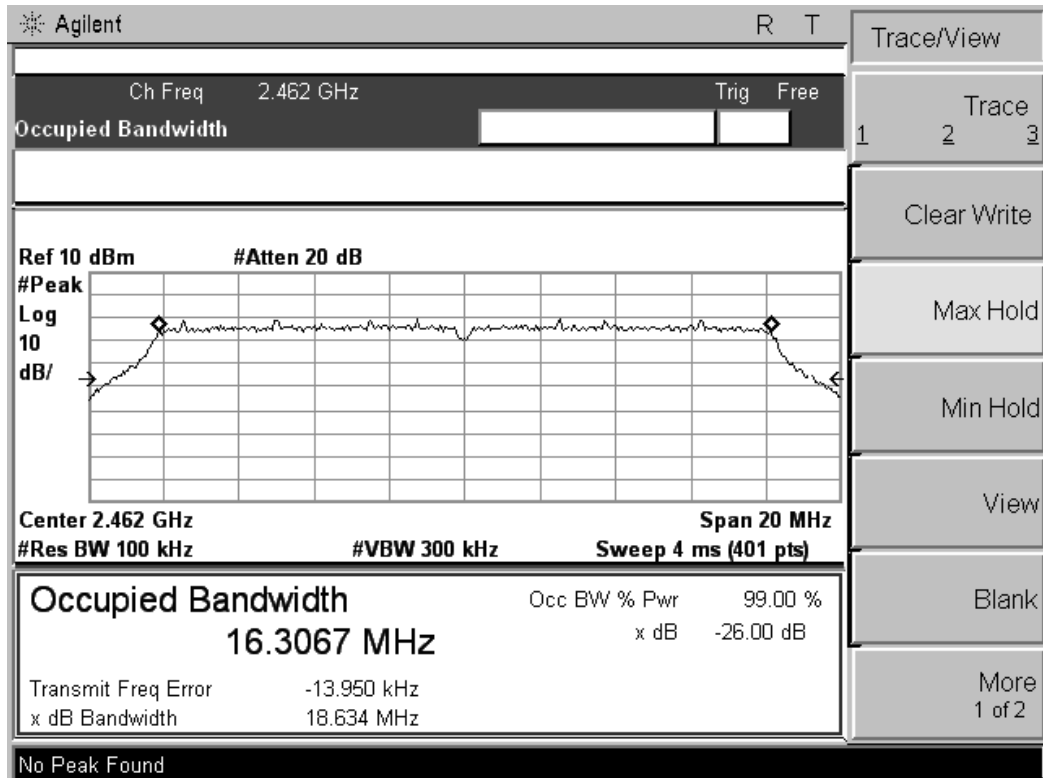

802.11n HT20 channel, 99% Occupied Bandwidth / port.1+ port.2

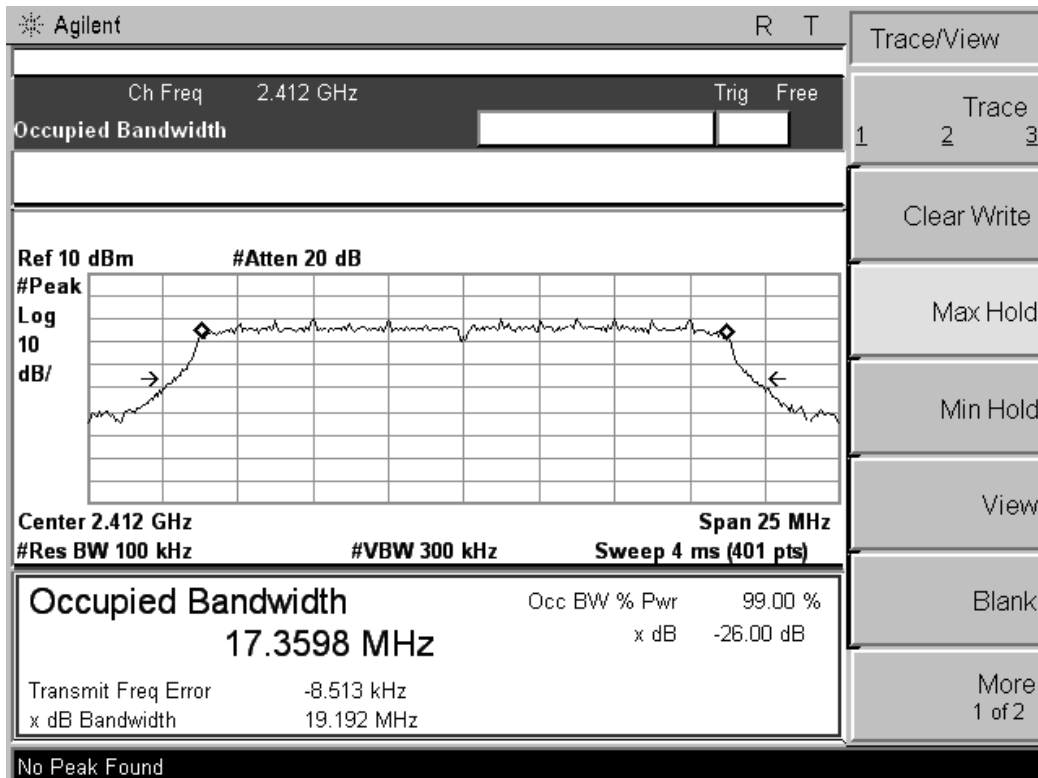

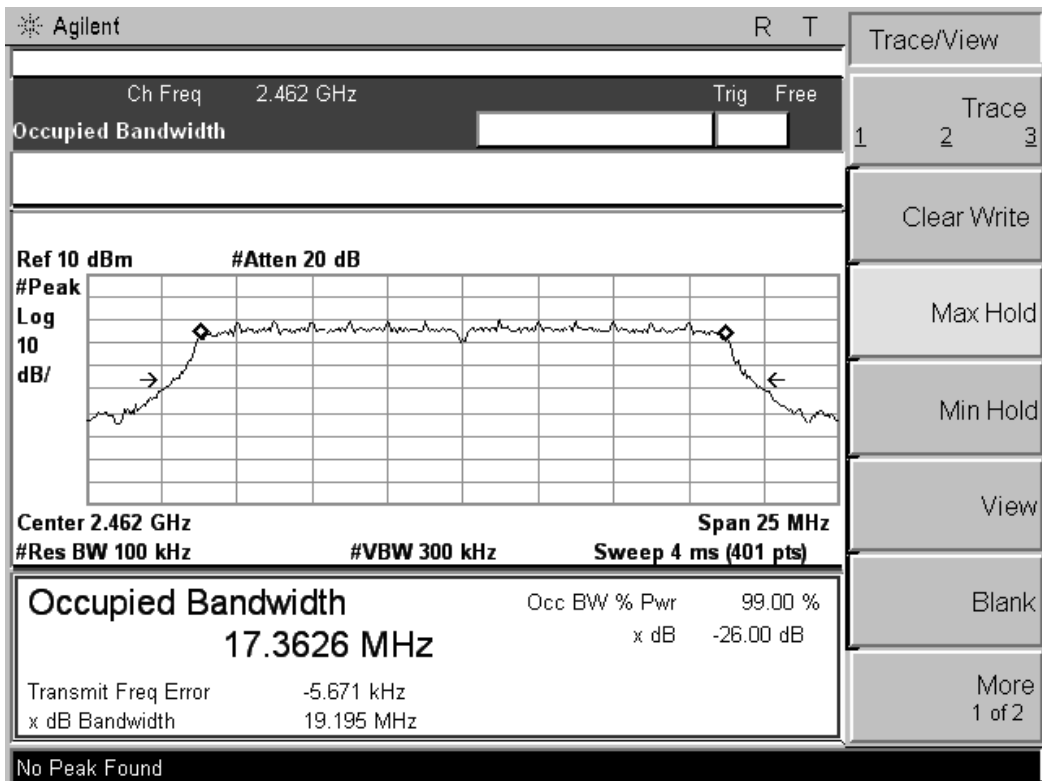
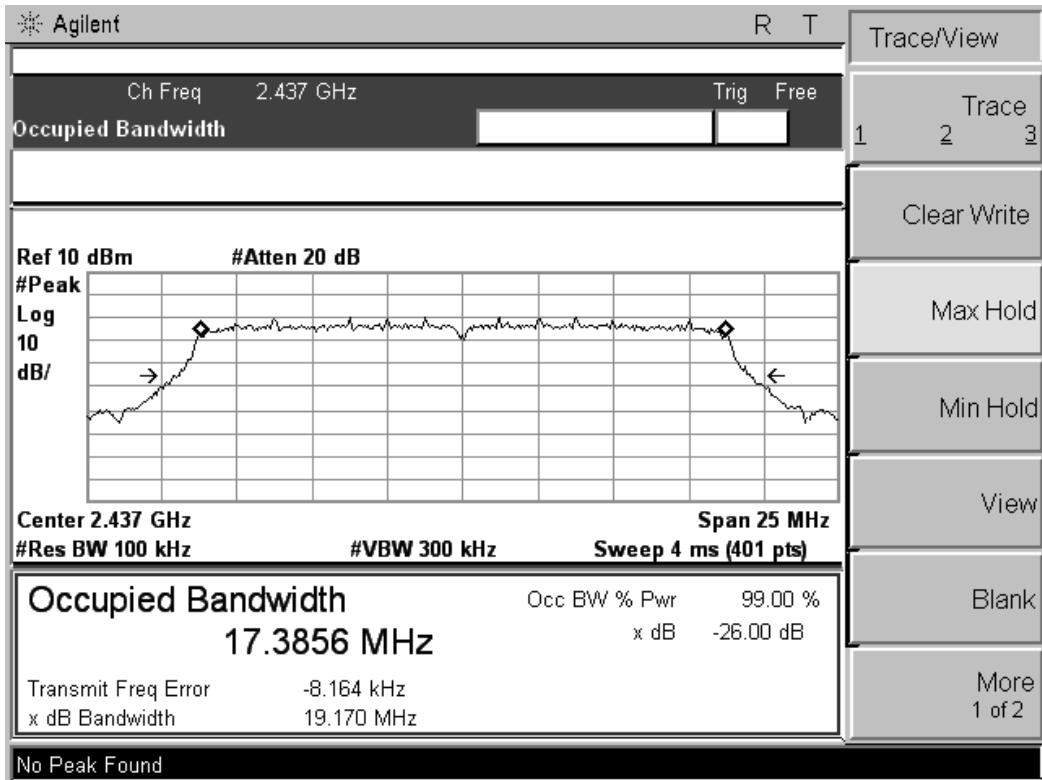

802.11n HT40 channel, 99% Occupied Bandwidth / port.1+ port.2

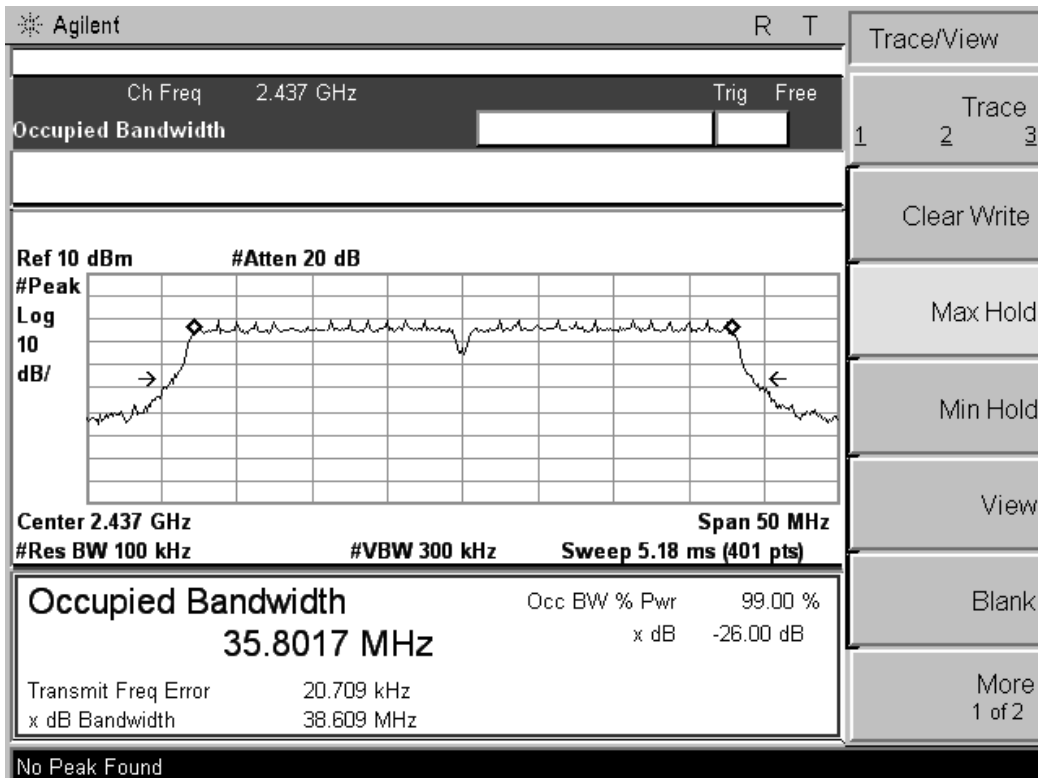
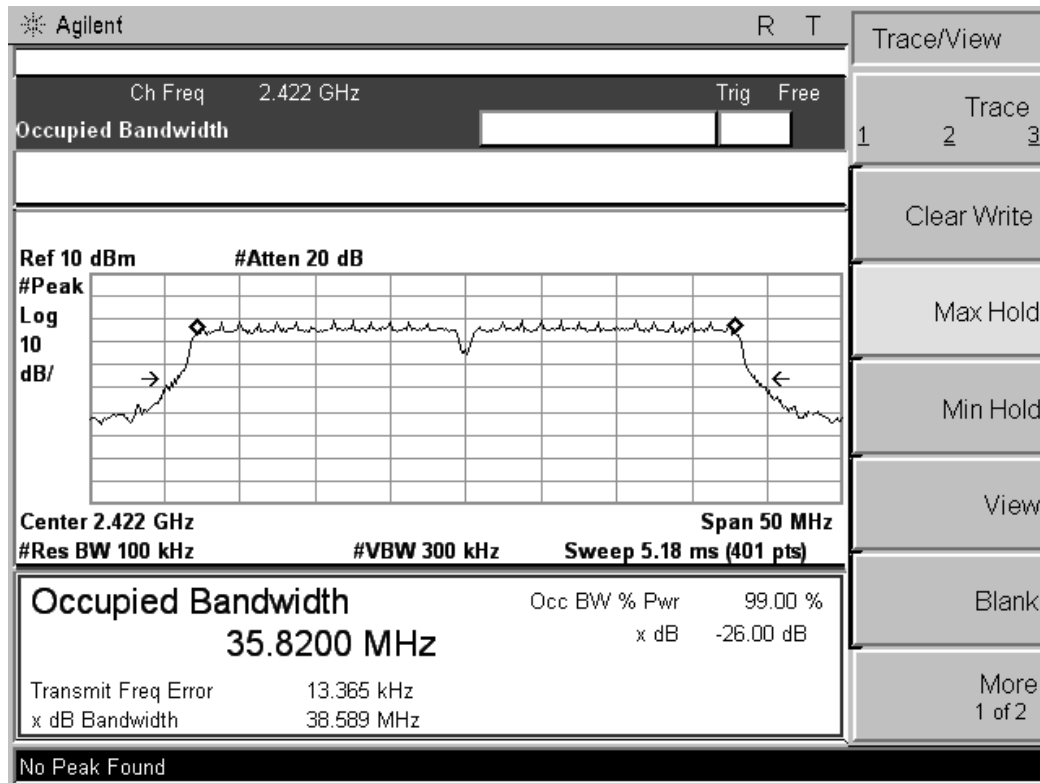

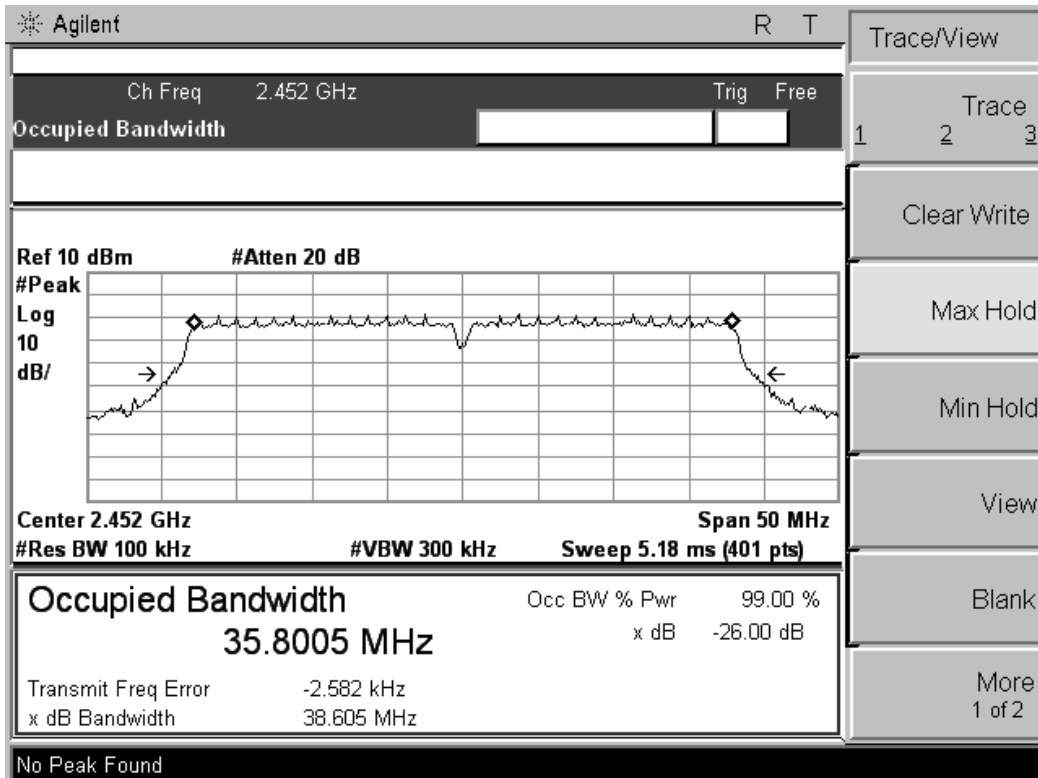

Test Plots of 5GHz Band

802.11n HT20 channel, 99% Occupied Bandwidth / port.1+ port.2

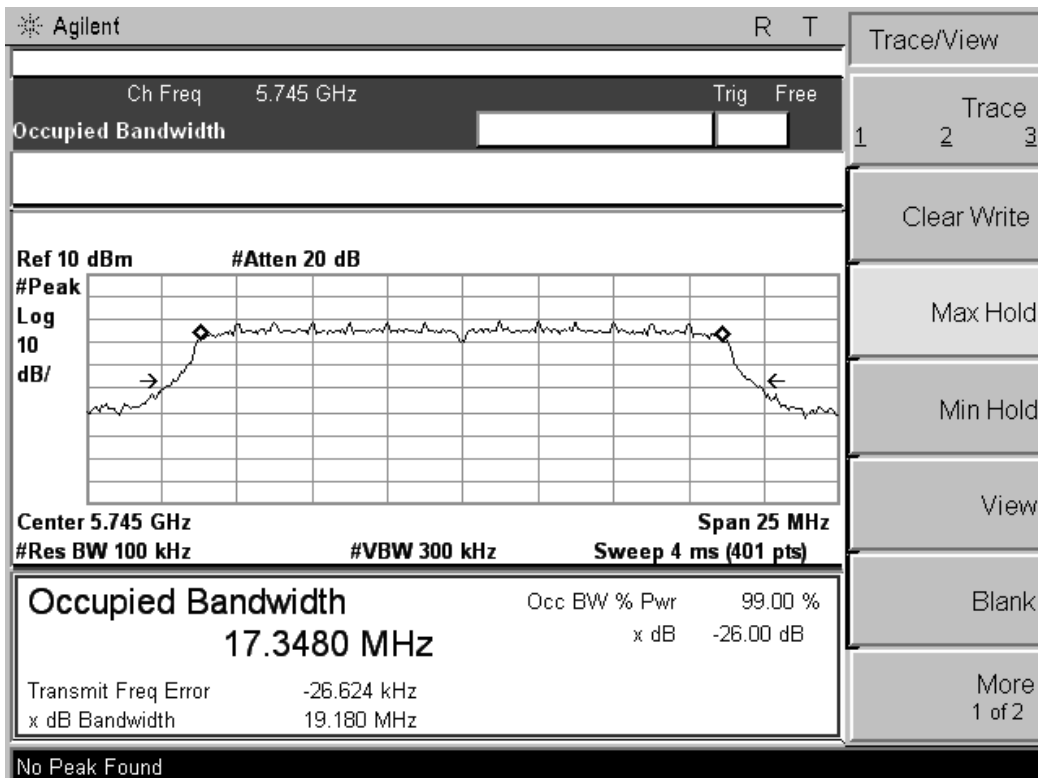

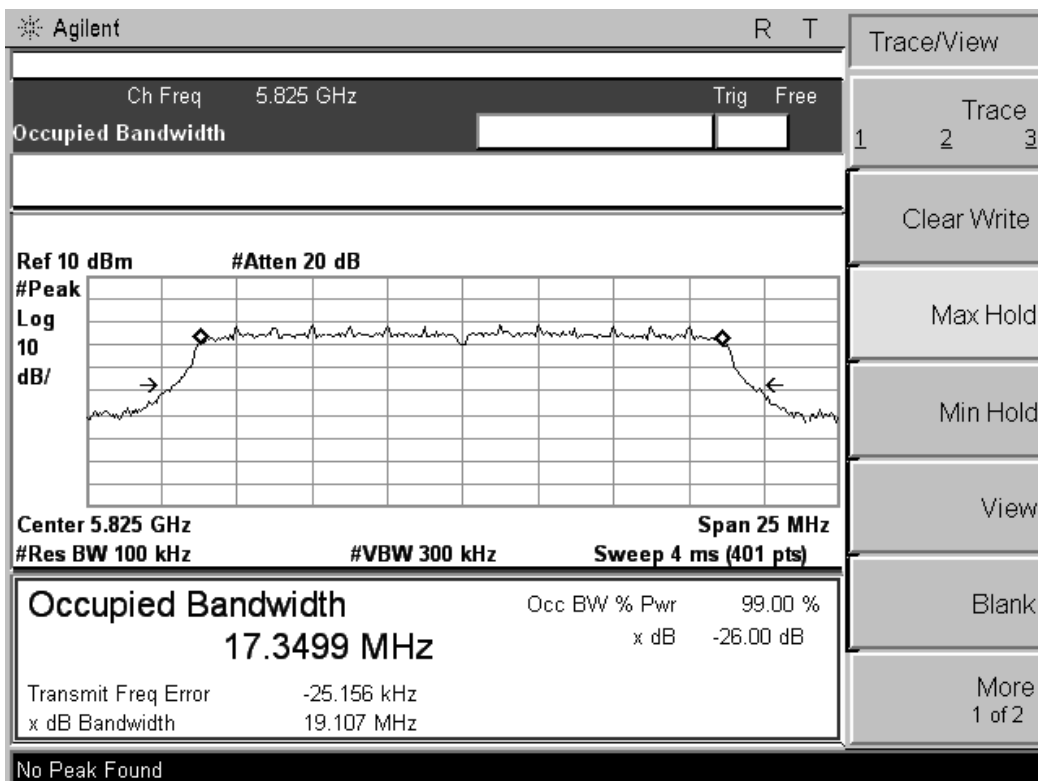
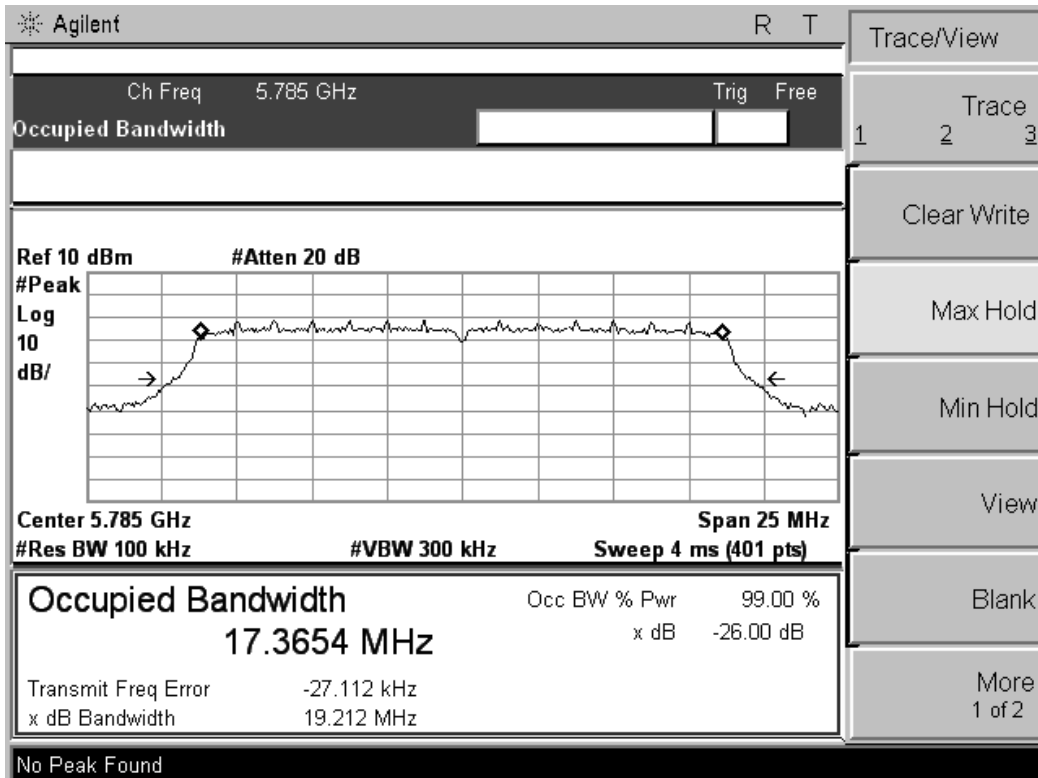

802.11n HT40 channel, 99% Occupied Bandwidth / port.1+ port.2

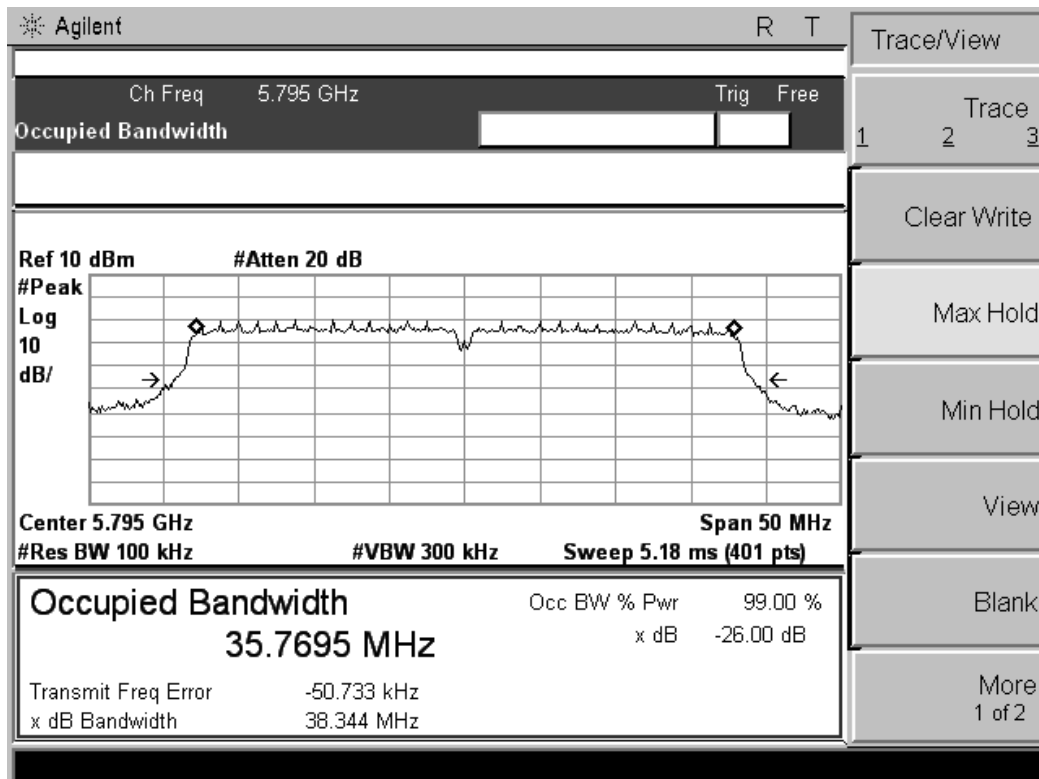
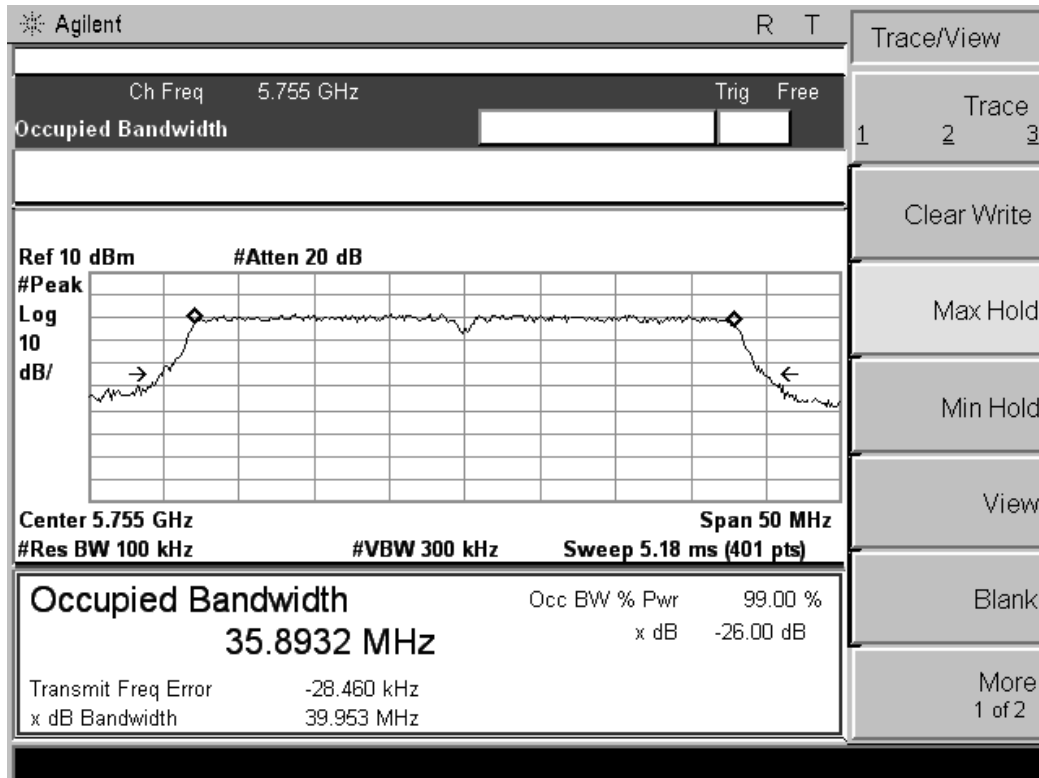

802.11a channel, 99% Occupied Bandwidth / port.1

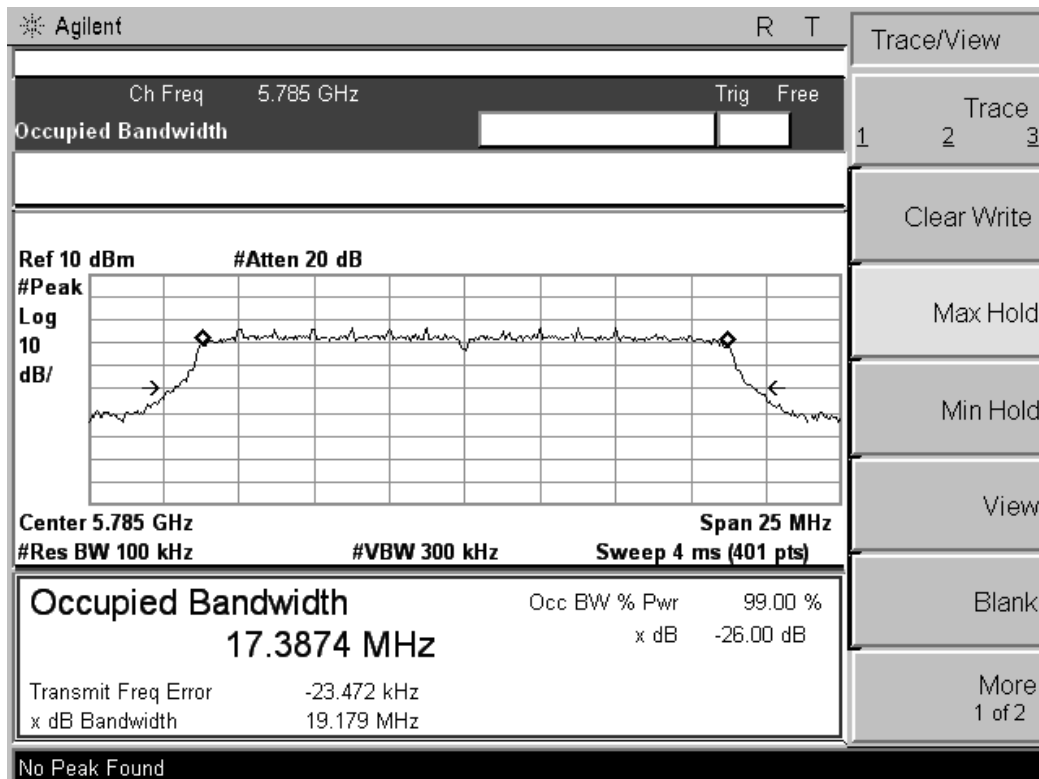
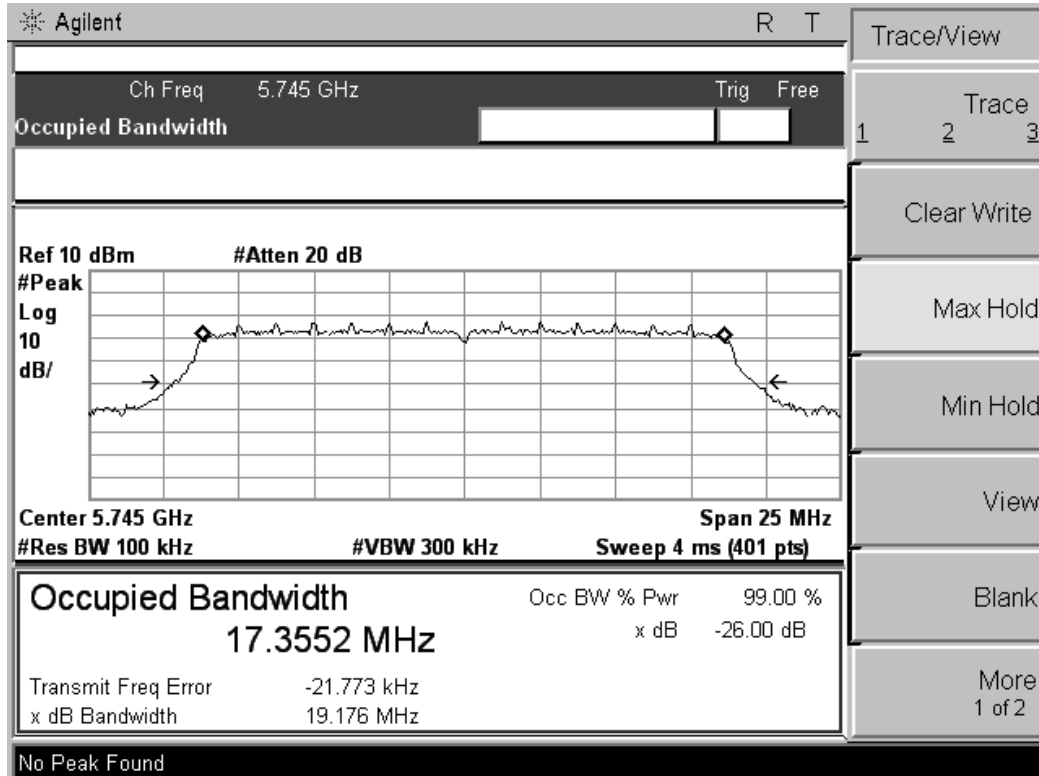

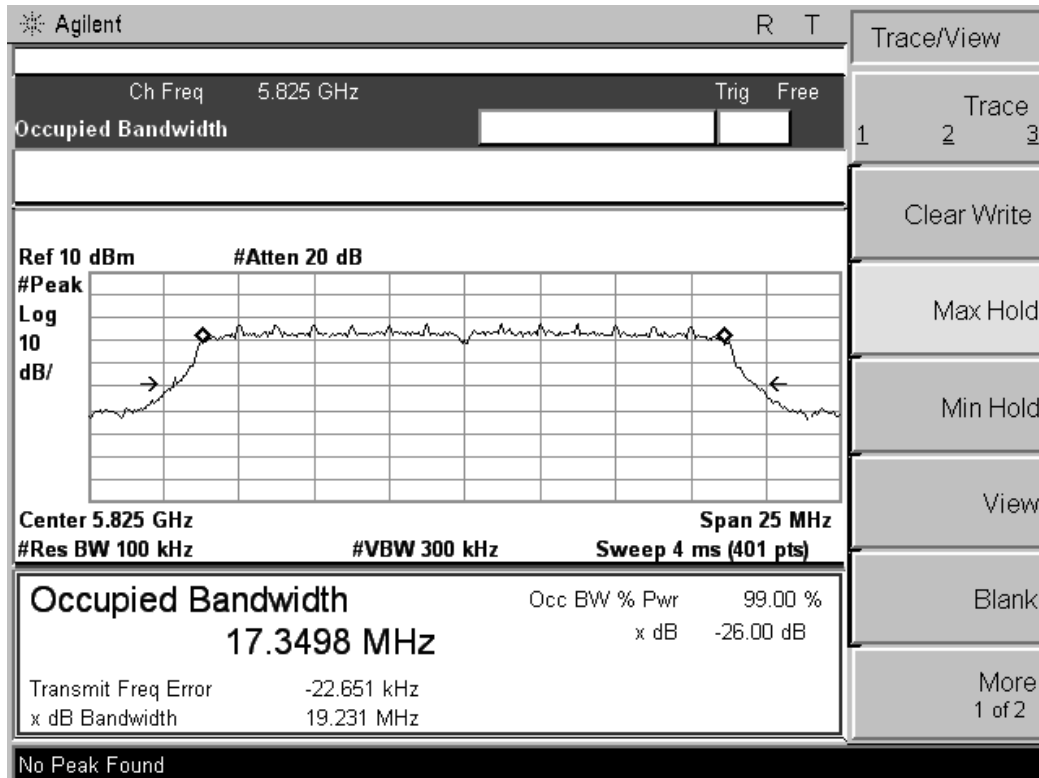

5.5. Radiated Emissions Measurement

5.5.1. Standard Applicable

According to §15.247 (d): 20dBc in any 100 kHz bandwidth outside the operating frequency band. In case the emission fall within the restricted band specified on 15.205(a), then the 15.209(a) limit in the table below has to be followed.

Frequencies(MHz)	Field Strength(microvolts/meter)	Measurement Distance(meters)
0.009~0.490	2400/F(KHz)	300
0.490~1.705	24000/F(KHz)	30
1.705~30.0	30	30
30~88	100	3
88~216	150	3
216~960	200	3
Above 960	500	3

5.5.2. Measuring Instruments and Setting

Please refer to section 6 of equipments list in this report. The following table is the setting of spectrum analyzer and receiver.

Spectrum Parameter	Setting
Attenuation	Auto
Start Frequency	1000 MHz
Stop Frequency	10th carrier harmonic
RB / VB (Emission in restricted band)	1MHz / 1MHz for Peak, 1 MHz / 10Hz for Average
RB / VB (Emission in non-restricted band)	1MHz / 1MHz for Peak, 1 MHz / 10Hz for Average

Receiver Parameter	Setting
Attenuation	Auto
Start ~ Stop Frequency	9kHz~150kHz / RB 200Hz for QP
Start ~ Stop Frequency	150kHz~30MHz / RB 9kHz for QP
Start ~ Stop Frequency	30MHz~1000MHz / RB 100kHz for QP

5.5.3. Test Procedures

1. Configure the EUT according to ANSI C63.4. The EUT was placed on the top of the turntable 0.8 meter above ground. The phase center of the receiving antenna mounted on the top of a height-variable antenna tower was placed 3 meters far away from the turntable.
2. Power on the EUT and all the supporting units. The turntable was rotated by 360 degrees to determine the position of the highest radiation.
3. The height of the broadband receiving antenna was varied between one meter and four meters above ground to find the maximum emissions field strength of both horizontal and vertical polarization.

4. For each suspected emissions, the antenna tower was scan (from 1 m to 4 m) and then the turntable was rotated (from 0 degree to 360 degrees) to find the maximum reading
5. Set the test-receiver system to Peak or CISPR quasi-peak Detect Function with specified bandwidth under Maximum Hold Mode.
6. For emissions above 1GHz, use 1MHz VBW and RBW for peak reading. Then 1MHz RBW and 10Hz VBW for average reading in spectrum analyzer.
7. When the radiated emissions limits are expressed in terms of the average value of the emissions, and pulsed operation is employed, the measurement field strength shall be determined by averaging over one complete pulse train, including blanking intervals, as long as the pulse train does not exceed 0.1 seconds. As an alternative (provided the transmitter operates for longer than 0.1 seconds) or in cases where the pulse train exceeds 0.1 seconds, the measured field strength shall be determined from the average absolute voltage during a 0.1 second interval during which the field strength is at its maximum value.
8. If the emissions level of the EUT in peak mode was 3 dB lower than the average limit specified, then testing will be stopped and peak values of EUT will be reported, otherwise, the emissions which do not have 3 dB margin will be repeated one by one using the quasi-peak method for below 1GHz.
9. For testing above 1GHz, the emissions level of the EUT in peak mode was lower than average limit (that means the emissions level in peak mode also complies with the limit in average mode), then testing will be stopped and peak values of EUT will be reported, otherwise, the emissions will be measured in average mode again and reported.
10. In case the emission is lower than 30MHz, loop antenna has to be used for measurement and the recorded data should be QP measured by receiver. High – Low scan is not required in this case.

5.5.4. Test Setup Layout

For radiated emissions below 30MHz

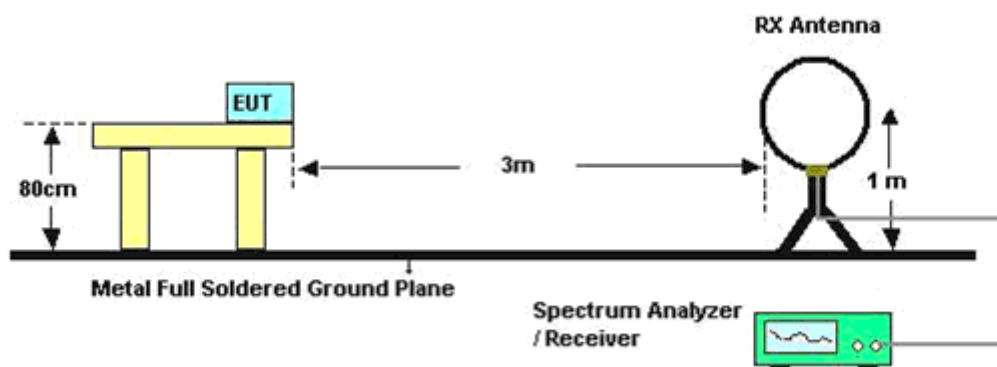

For radiated emissions above 30MHz

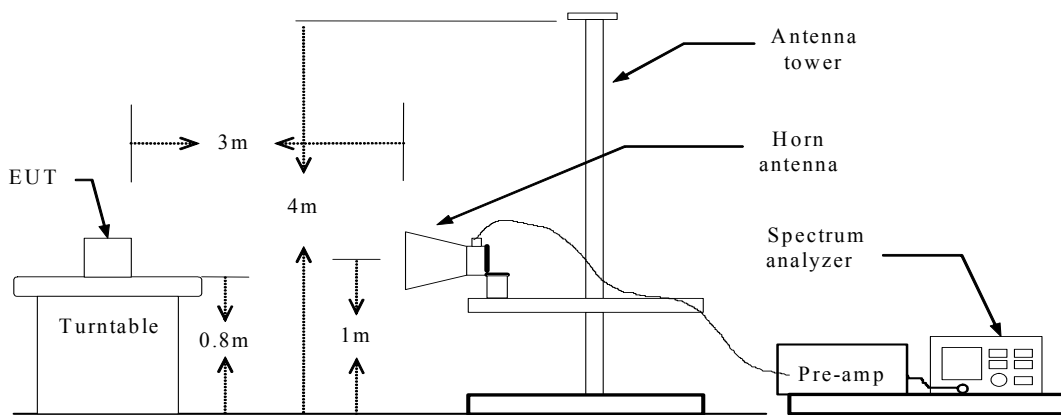
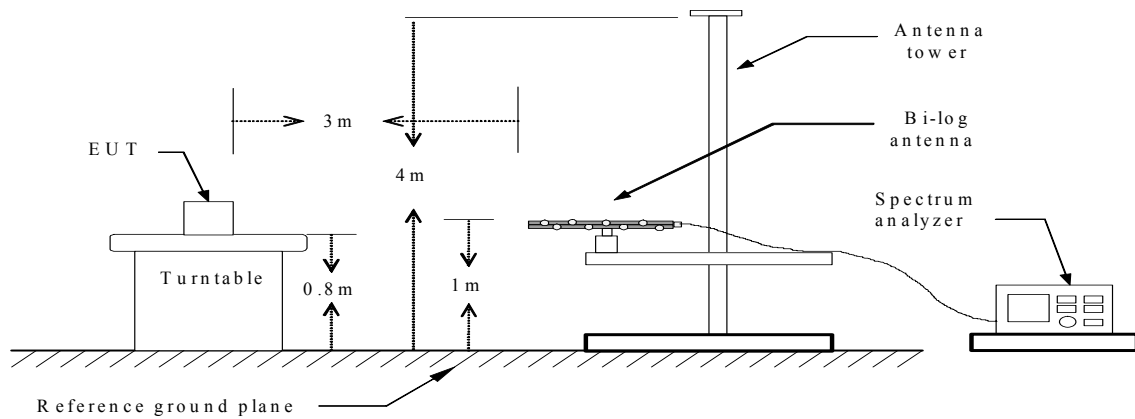

Above 10 GHz shall be extrapolated to the specified distance using an extrapolation factor of 20 dB/decade from 3m to 1.5m.

Distance extrapolation factor = $20 \log (\text{specific distance [3m]} / \text{test distance [1.5m]})$ (dB);

Limit line = specific limits (dBuV) + distance extrapolation factor [6 dB].

5.5.5. EUT Operation during Test

The EUT was programmed to be in continuously transmitting mode.

5.5.6. Results of Radiated Emissions (9kHz~30MHz)

Temperature	25°C	Humidity	60%
Test Engineer	Leo	Configurations	802.11a/b/g/n

Freq. (MHz)	Level (dBuV)	Over Limit (dB)	Over Limit (dBuV)	Remark
-	-	-	-	See Note

Note:

The amplitude of spurious emissions which are attenuated by more than 20 dB below the permissible value has no need to be reported.

Distance extrapolation factor = 40 log (specific distance / test distance) (dB);

Limit line = specific limits (dBuV) + distance extrapolation factor.

5.5.7. Results of Radiated Emissions (30MHz~1GHz)

Temperature	25°C	Humidity	60%
Test Engineer	Leo	Configurations	802.11n HT20 (Low CH, 2.4GHz Band)

Test result for 802.11n HT20 (Low Channel, 2.4GHz Band)

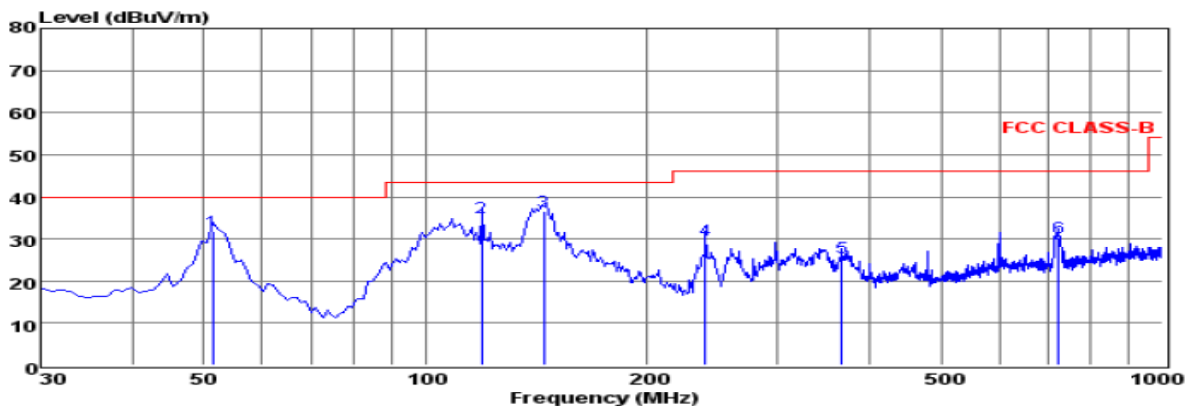

```

Env. /Ins:          24°C / 56%
EUT:               300Mbps 802.11n/a/b/g Wireless Dual Band USB Adapter
M/N:               RNX-N600UBE
Power Rating:      DC 5V
Test Mode:         Tx-2412 (802.11n20, 2.4G)
Operator:          Andy
Memo:
pol:               HORIZONTAL
    
```

	Freq	Reading	CabLos	AntFac	PreFac	Measured	Limit	Over	Remark
	MHz	dBuV	dB	dB/m	dB	dBuV/m	dBuV/m	dB	
1	51.34	18.15	0.54	13.19	0.00	31.88	40.00	-8.12	QP
2	119.24	23.84	0.64	10.61	0.00	35.09	43.50	-8.41	QP
3	144.46	27.49	0.77	8.22	0.00	36.48	43.50	-7.02	QP
4	239.52	16.60	1.01	12.07	0.00	29.68	46.00	-16.32	QP
5	366.59	10.09	1.14	14.48	0.00	25.71	46.00	-20.29	QP
6	722.58	9.73	1.63	19.09	0.00	30.45	46.00	-15.55	QP

Note: 1. All readings are Quasi-peak values.
 2. Measured = Reading + Antenna Factor + Cable Loss - Amp Factor.
 3. The emission levels that are 20dB below the official limit are not reported.

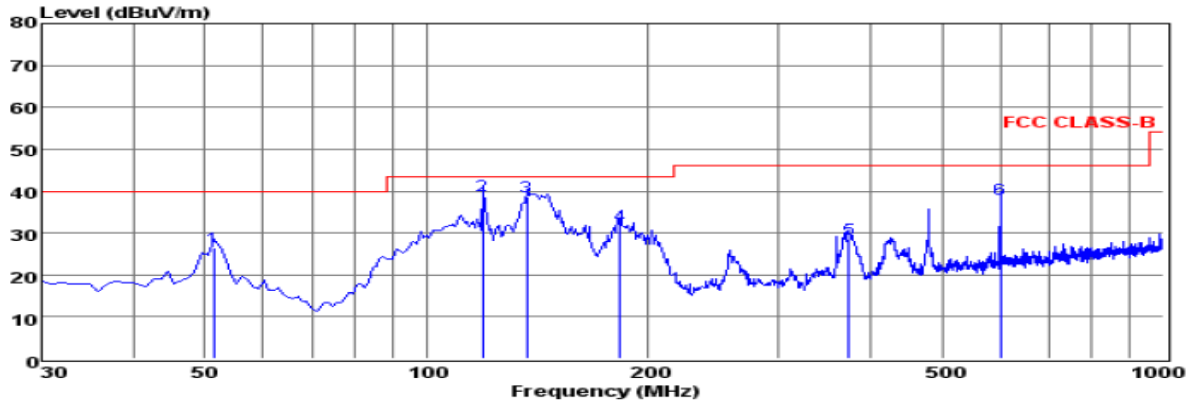

Env. /Ins: 24°C /56%
 EUT: 300Mbps 802.11n/a/b/g Wireless Dual Band USB Adapter
 M/N: RNX-N600UBE
 Power Rating: DC 5V
 Test Mode: Tx-2412(802.11n20, 2.4G)
 Operator: Andy
 Memo:
 pol: VERTICAL

	Freq	Reading	CabLos	AntFac	PreFac	Measured	Limit	Over	Remark
	MHz	dBuV	dB	dB/m	dB	dBuV/m	dBuV/m	dB	
1	51.34	12.67	0.54	13.19	0.00	26.40	40.00	-13.60	QP
2	119.24	27.57	0.64	10.61	0.00	38.82	43.50	-4.68	QP
3	136.70	29.41	0.70	8.43	0.00	38.54	43.50	-4.96	QP
4	183.26	21.02	0.70	9.97	0.00	31.69	43.50	-11.81	QP
5	374.35	12.92	1.10	14.54	0.00	28.56	46.00	-17.44	QP
6	600.36	18.06	1.43	18.45	0.00	37.94	46.00	-8.06	QP

Note: 1. All readings are Quasi-peak values.
 2. Measured = Reading + Antenna Factor + Cable Loss - Amp Factor.
 3. The emission levels that are 20dB below the official limit are not reported.

Note:

Pre-scan all mode and recorded the worst case results in this report (802.11n HT20 (Low Channel, 2.4GHz Band)).

Emission level (dBuV/m) = 20 log Emission level (uV/m).

Corrected Reading: Antenna Factor + Cable Loss + Read Level - Preamp Factor = Level.

5.5.8. Results for Radiated Emissions (Above 1GHz)

For 2.4GHz Band:

802.11b/Port.1

Channel 1

Freq MHz	Read Level dBuV	Ant. Fac dB/m	Pre. Fac dB	Cab.Los dB	Limit Line dBuV/m	Over limit dB	Remark	Pol/Phase
4824.11	49.31	33.06	35.04	3.94	74	-22.73	Peak	Horizontal
4824.24	38.67	33.06	35.04	3.94	54	-13.37	Average	Horizontal
4824.11	49.74	33.06	35.04	3.94	74	-22.30	Peak	Vertical
4824.23	39.24	33.06	35.04	3.94	54	-12.80	Average	Vertical

Channel 6

Freq MHz	Read Level dBuV	Ant. Fac dB/m	Pre. Fac dB	Cab.Los dB	Limit Line dBuV/m	Over limit dB	Remark	Pol/Phase
4874.64	49.41	33.16	35.15	3.96	74	-22.62	Peak	Horizontal
4874.64	38.27	33.16	35.15	3.96	54	-13.76	Average	Horizontal
4874.64	49.43	33.16	35.15	3.96	74	-22.60	Peak	Vertical
4874.64	39.11	33.16	35.15	3.96	54	-12.92	Average	Vertical

Channel 11

Freq MHz	Read Level dBuV	Ant. Fac dB/m	Pre. Fac dB	Cab.Los dB	Limit Line dBuV/m	Over limit dB	Remark	Pol/Phase
4924.36	48.27	33.26	35.14	3.98	74	-23.63	Peak	Horizontal
4924.36	38.71	33.26	35.14	3.98	54	-13.19	Average	Horizontal
4924.36	47.13	33.26	35.14	3.98	74	-24.77	Peak	Vertical
4924.36	36.84	33.26	35.14	3.98	54	-15.06	Average	Vertical

802.11g/Port.1

Channel 1

Freq MHz	Read Level dBuV	Ant. Fac dB/m	Pre. Fac dB	Cab.Los dB	Limit Line dBuV/m	Over limit dB	Remark	Pol/Phase
4824.73	47.11	33.06	35.04	3.94	74	-24.93	Peak	Horizontal
4824.91	35.31	33.06	35.04	3.94	54	-16.73	Average	Horizontal
4824.71	46.69	33.06	35.04	3.94	74	-25.35	Peak	Vertical
4824.93	34.54	33.06	35.04	3.94	54	-17.50	Average	Vertical

Channel 6

Freq MHz	Read Level dBuV	Ant. Fac dB/m	Pre. Fac dB	Cab.Los dB	Limit Line dBuV/m	Over limit dB	Remark	Pol/Phase
4874.35	46.27	33.16	35.15	3.96	74	-25.76	Peak	Horizontal
4874.35	35.14	33.16	35.15	3.96	54	-16.89	Average	Horizontal
4874.35	45.69	33.16	35.15	3.96	74	-26.34	Peak	Vertical
4874.35	34.41	33.16	35.15	3.96	54	-17.62	Average	Vertical

Channel 11

Freq MHz	Read Level dBuV	Ant. Fac dB/m	Pre. Fac dB	Cab.Los dB	Limit Line dBuV/m	Over limit dB	Remark	Pol/Phase
4924.81	48.61	33.26	35.14	3.98	74	-23.29	Peak	Horizontal
4924.81	36.03	33.26	35.14	3.98	54	-15.87	Average	Horizontal
4924.81	46.19	33.26	35.14	3.98	74	-25.71	Peak	Vertical
4924.81	35.49	33.26	35.14	3.98	54	-16.41	Average	Vertical

802.11n HT20/Port.1+Port.2

Channel 1

Freq MHz	Read Level dBuV	Ant. Fac dB/m	Pre. Fac dB	Cab.Los dB	Limit Line dBuV/m	Over limit dB	Remark	Pol/Phase
4824.75	43.21	33.06	35.04	3.94	74	-28.83	Peak	Horizontal
4824.96	33.76	33.06	35.04	3.94	54	-18.28	Average	Horizontal
4824.75	42.07	33.06	35.04	3.94	74	-29.97	Peak	Vertical
4824.96	32.43	33.06	35.04	3.94	54	-19.61	Average	Vertical

Channel 6

Freq MHz	Read Level dBuV	Ant. Fac dB/m	Pre. Fac dB	Cab.Los dB	Limit Line dBuV/m	Over limit dB	Remark	Pol/Phase
4874.42	44.64	33.16	35.15	3.96	74	-27.39	Peak	Horizontal
4874.42	34.11	33.16	35.15	3.96	54	-17.92	Average	Horizontal
4874.42	43.27	33.16	35.15	3.96	74	-28.76	Peak	Vertical
4874.42	33.54	33.16	35.15	3.96	54	-18.49	Average	Vertical

Channel 11

Freq MHz	Read Level dBuV	Ant. Fac dB/m	Pre. Fac dB	Cab.Los dB	Limit Line dBuV/m	Over limit dB	Remark	Pol/Phase
4924.68	47.13	33.26	35.14	3.98	74	-24.77	Peak	Horizontal
4924.68	38.26	33.26	35.14	3.98	54	-13.64	Average	Horizontal
4924.68	45.67	33.26	35.14	3.98	74	-26.23	Peak	Vertical
4924.68	39.74	33.26	35.14	3.98	54	-12.16	Average	Vertical

802.11n HT40/Port.1+Port.2

Channel 3

Freq MHz	Read Level dBuV	Ant. Fac dB/m	Pre. Fac dB	Cab.Los dB	Limit Line dBuV/m	Over limit dB	Remark	Pol/Phase
4844.71	43.21	33.06	35.04	3.94	74	-28.83	Peak	Horizontal
4844.93	33.76	33.06	35.04	3.94	54	-18.28	Average	Horizontal
4844.72	42.07	33.06	35.04	3.94	74	-29.97	Peak	Vertical
4844.91	32.43	33.06	35.04	3.94	54	-19.61	Average	Vertical

Channel 6

Freq MHz	Read Level dBuV	Ant. Fac dB/m	Pre. Fac dB	Cab.Los dB	Limit Line dBuV/m	Over limit dB	Remark	Pol/Phase
4874.42	44.64	33.16	35.15	3.96	74	-27.39	Peak	Horizontal
4874.42	34.11	33.16	35.15	3.96	54	-17.92	Average	Horizontal
4874.42	43.27	33.16	35.15	3.96	74	-28.76	Peak	Vertical
4874.42	33.54	33.16	35.15	3.96	54	-18.49	Average	Vertical

Channel 9

Freq MHz	Read Level dBuV	Ant. Fac dB/m	Pre. Fac dB	Cab.Los dB	Limit Line dBuV/m	Over limit dB	Remark	Pol/Phase
4904.63	47.13	33.26	35.14	3.98	74	-24.77	Peak	Horizontal
4904.62	38.26	33.26	35.14	3.98	54	-13.64	Average	Horizontal
4904.63	45.67	33.26	35.14	3.98	74	-26.23	Peak	Vertical
4904.61	39.74	33.26	35.14	3.98	54	-12.16	Average	Vertical

For 5GHz Band:

802.11 HT20/Port.1+Port.2

Channel 149

Freq GHz	Read Level dBuV	Ant. Fac dB/m	Pre. Fac dB	Cab.Los dB	Limit Line dBuV/m	Over limit dB	Remark	Pol/Phase
11.49	45.37	33.06	35.04	3.94	74	-26.67	Peak	Horizontal
11.49	35.62	33.06	35.04	3.94	54	-16.42	Average	Horizontal
17.235	44.74	33.06	35.04	3.94	74	-27.3	Peak	Vertical
17.235	33.69	33.06	35.04	3.94	54	-18.35	Average	Vertical

Channel 157

Freq GHz	Read Level dBuV	Ant. Fac dB/m	Pre. Fac dB	Cab.Los dB	Limit Line dBuV/m	Over limit dB	Remark	Pol/Phase
11.57	46.28	33.16	35.15	3.96	74	-25.75	Peak	Horizontal
11.57	38.16	33.16	35.15	3.96	54	-13.87	Average	Horizontal
17.335	45.77	33.16	35.15	3.96	74	-26.26	Peak	Vertical
17.335	39.45	33.16	35.15	3.96	54	-12.58	Average	Vertical

Channel 165

Freq GHz	Read Level dBuV	Ant. Fac dB/m	Pre. Fac dB	Cab.Los dB	Limit Line dBuV/m	Over limit dB	Remark	Pol/Phase
11.65	48.72	33.26	35.14	3.98	74	-23.18	Peak	Horizontal
11.65	39.18	33.26	35.14	3.98	54	-12.72	Average	Horizontal
17.475	46.22	33.26	35.14	3.98	74	-25.68	Peak	Vertical
17.475	40.29	33.26	35.14	3.98	54	-11.61	Average	Vertical

802.11 HT40/Port.1+Port.2

Channel 151

Freq GHz	Read Level dBuV	Ant. Fac dB/m	Pre. Fac dB	Cab.Los dB	Limit Line dBuV/m	Over limit dB	Remark	Pol/Phase
11.51	43.23	33.06	35.04	3.94	74	-28.67	Peak	Horizontal
11.51	33.74	33.06	35.04	3.94	54	-18.16	Average	Horizontal
17.265	42.19	33.06	35.04	3.94	74	-29.71	Peak	Vertical
17.265	32.53	33.06	35.04	3.94	54	-19.37	Average	Vertical

Channel 159

Freq GHz	Read Level dBuV	Ant. Fac dB/m	Pre. Fac dB	Cab.Los dB	Limit Line dBuV/m	Over limit dB	Remark	Pol/Phase
11.59	44.7	33.16	35.15	3.96	74	-27.2	Peak	Horizontal
11.59	34.19	33.16	35.15	3.96	54	-17.71	Average	Horizontal
17.385	43.23	33.16	35.15	3.96	74	-28.67	Peak	Vertical
17.385	33.56	33.16	35.15	3.96	54	-18.34	Average	Vertical

802.11a/Port.1

Channel 149

Freq GHz	Read Level dBuV	Ant. Fac dB/m	Pre. Fac dB	Cab.Los dB	Limit Line dBuV/m	Over limit dB	Remark	Pol/Phase
11.49	45.71	33.06	35.04	3.94	74	-26.33	Peak	Horizontal
11.49	37.25	33.06	35.04	3.94	54	-14.79	Average	Horizontal
17.235	46.28	33.06	35.04	3.94	74	-25.76	Peak	Vertical
17.235	38.16	33.06	35.04	3.94	54	-13.88	Average	Vertical

Channel 157

Freq GHz	Read Level dBuV	Ant. Fac dB/m	Pre. Fac dB	Cab.Los dB	Limit Line dBuV/m	Over limit dB	Remark	Pol/Phase
11.57	45.89	33.16	35.15	3.96	74	-26.14	Peak	Horizontal
11.57	34.12	33.16	35.15	3.96	54	-17.91	Average	Horizontal
17.335	44.31	33.16	35.15	3.96	74	-27.72	Peak	Vertical
17.335	33.79	33.16	35.15	3.96	54	-18.24	Average	Vertical

Channel 165

Freq GHz	Read Level dBuV	Ant. Fac dB/m	Pre. Fac dB	Cab.Los dB	Limit Line dBuV/m	Over limit dB	Remark	Pol/Phase
11.65	44.26	33.26	35.14	3.98	74	-27.64	Peak	Horizontal
11.65	32.68	33.26	35.14	3.98	54	-19.22	Average	Horizontal
17.475	43.17	33.26	35.14	3.98	74	-28.73	Peak	Vertical
17.475	31.95	33.26	35.14	3.98	54	-19.95	Average	Vertical

Notes:

1. Measuring frequencies from 9k~10th harmonic or 40GHz (which is less), No emission found between lowest internal used/generated frequency to 30 MHz.
2. Radiated emissions measured in frequency range from 9k~10th harmonic or 40GHz (which is less) were made with an instrument using Peak detector mode.
3. Data of measurement within this frequency range shown “ --- ” in the table above means the reading of emissions are attenuated more than 20dB below the permissible limits or the field strength is too small to be measured.

5.5.9. Results of 5GHz Band 4 for Band Edges Test (Radiated)

802.11 HT20/Port.1+Port.2

Channel 149

Freq. MHz	Read Level dBuV	Ant. Fac dB/m	Pre. Fac dB	Cab.Los dB	Limit Line dBuV/m	Over limit dB	Remark	Pol/Phase
5380.11	59.31	33.26	35.14	3.98	74	-12.59	Peak	Horizontal
5380.09	43.67	33.26	35.14	3.98	54	-8.23	Average	Horizontal
5410.00	47.43	33.26	35.16	4.01	74	-24.46	Peak	Horizontal
5410.00	41.17	33.26	35.16	4.01	54	-10.72	Average	Horizontal
5725.00	47.59	33.28	35.18	4.05	74	-24.26	Peak	Vertical
5724.97	40.24	33.28	35.18	4.05	54	-11.61	Average	Vertical

Channel 165

Freq. MHz	Read Level dBuV	Ant. Fac dB/m	Pre. Fac dB	Cab.Los dB	Limit Line dBuV/m	Over limit dB	Remark	Pol/Phase
5851.11	59.39	33.30	35.20	4.06	74	-12.45	Peak	Horizontal
5851.09	43.77	33.30	35.20	4.06	54	-8.07	Average	Horizontal
5950.00	48.43	33.30	35.22	4.08	74	-23.41	Peak	Horizontal
5950.00	41.19	33.30	35.22	4.08	54	-10.65	Average	Horizontal

802.11 HT40/Port.1+Port.2

Channel 151

Freq MHz	Read Level dBuV	Ant. Fac dB/m	Pre. Fac dB	Cab.Los dB	Limit Line dBuV/m	Over limit dB	Remark	Pol/Phase
5400.00	58.77	33.26	35.14	3.98	74	-13.13	Peak	Horizontal
5400.00	41.10	33.26	35.14	3.98	54	-10.80	Average	Horizontal
5730.56	48.01	33.28	35.18	4.05	74	-23.84	Peak	Vertical
5730.56	39.87	33.28	35.18	4.05	54	-11.98	Average	Vertical

Channel 159

Freq MHz	Read Level dBuV	Ant. Fac dB/m	Pre. Fac dB	Cab.Los dB	Limit Line dBuV/m	Over limit dB	Remark	Pol/Phase
5850.00	60.71	33.30	35.20	4.06	74	-11.13	Peak	Horizontal
5850.00	43.66	33.30	35.20	4.06	54	-8.18	Average	Horizontal
5950.56	49.31	33.30	35.22	4.08	74	-22.53	Peak	Vertical
5950.56	40.02	33.30	35.22	4.08	54	-11.82	Average	Vertical

802.11a/Port.1

Channel 149

Freq MHz	Read Level dBuV	Ant. Fac dB/m	Pre. Fac dB	Cab.Los dB	Limit Line dBuV/m	Over limit dB	Remark	Pol/Phase
5380.11	60.12	33.26	35.14	3.98	74	-11.78	Peak	Horizontal
5380.09	43.77	33.26	35.14	3.98	54	-8.13	Average	Horizontal
5410.00	48.56	33.26	35.16	4.01	74	-23.33	Peak	Vertical
5410.00	41.64	33.26	35.16	4.01	54	-10.25	Average	Vertical
5725.00	47.78	33.28	35.18	4.05	74	-24.07	Peak	Vertical
5724.97	40.33	33.28	35.18	4.05	54	-11.52	Average	Vertical

Channel 165

Freq MHz	Read Level dBuV	Ant. Fac dB/m	Pre. Fac dB	Cab.Los dB	Limit Line dBuV/m	Over limit dB	Remark	Pol/Phase
5851.11	59.57	33.30	35.20	4.06	74	-12.27	Peak	Horizontal
5851.09	43.83	33.30	35.20	4.06	54	-8.01	Average	Horizontal
5950.00	48.66	33.30	35.22	4.08	74	-23.18	Peak	Vertical
5950.00	41.31	33.30	35.22	4.08	54	-10.53	Average	Vertical

5.6. Conducted Spurious Emissions and Band Edges Test

5.6.1. Standard Applicable

According to §15.247 (d): In any 100 kHz bandwidth outside the frequency band in which the spread spectrum or digitally modulated intentional radiator is operating, the radio frequency power that is produced by the intentional radiator shall be at least 20 dB below that in the 100 kHz bandwidth within the band that contains the highest level of the desired power, based on either an RF conducted or a radiated measurement. Attenuation below the general limits specified in Section 15.209(a) is not required. In addition, radiated emissions which fall in the restricted bands, as defined in Section 15.205(a), must also comply with the radiated emission limits specified in Section 15.209(a) (see Section 15.205(c)).

5.6.2. Measuring Instruments and Setting

Please refer to section 6 of equipments list in this report. The following table is the setting of the spectrum analyzer.

Spectrum Parameter	Setting
Detector	Peak
Attenuation	Auto
RB / VB (Emission in restricted band)	100KHz/300KHz
RB / VB (Emission in non-restricted band)	100KHz/300KHz

5.6.3. Test Procedures

The transmitter output is connected to a spectrum analyzer. The resolution bandwidth is set to 100 kHz. The video bandwidth is set to 100 kHz

The spectrum from 9kHz to 40GHz is investigated with the transmitter set to the lowest, middle, and highest channels.

Preliminary tests on individual chains, and on all chains with a combiner, were performed. The worst-case configuration was with a combiner, therefore final test were performed with all chains feeding a combiner.

5.6.4. Test Setup Layout

This test setup layout is the same as that shown in section 5.4.4.

5.6.5. EUT Operation during Test

The EUT was programmed to be in continuously transmitting mode.

5.6.6. Test Results of Conducted Spurious Emissions

For 2.4GHz Band:

802.11b/Port.1

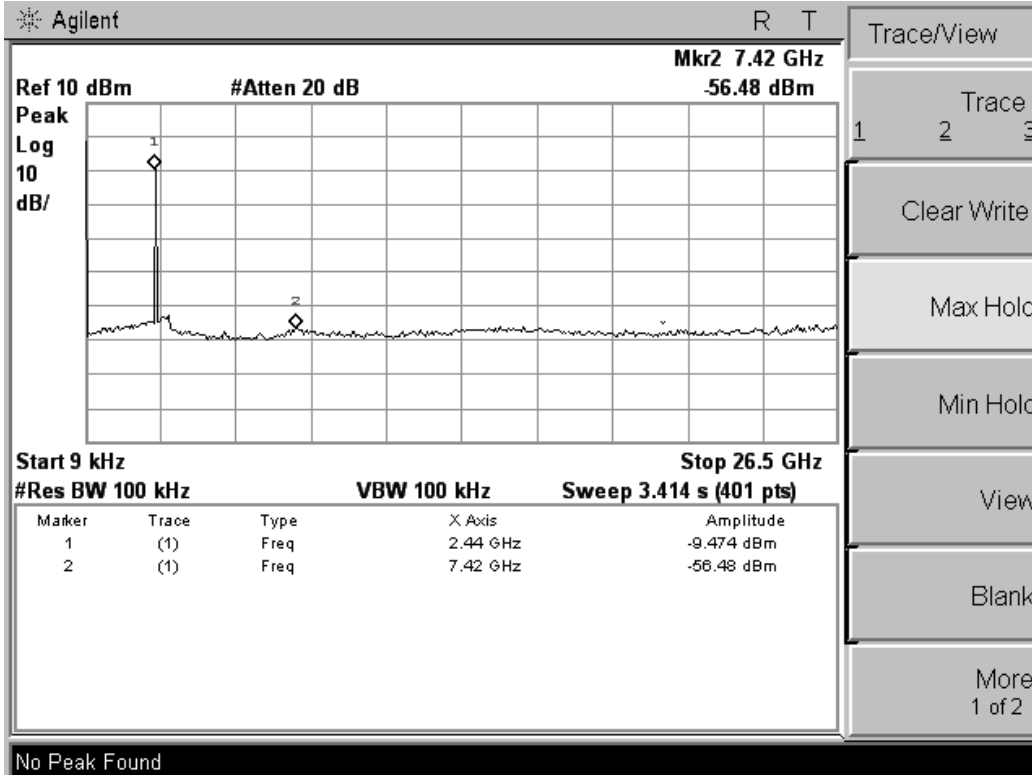
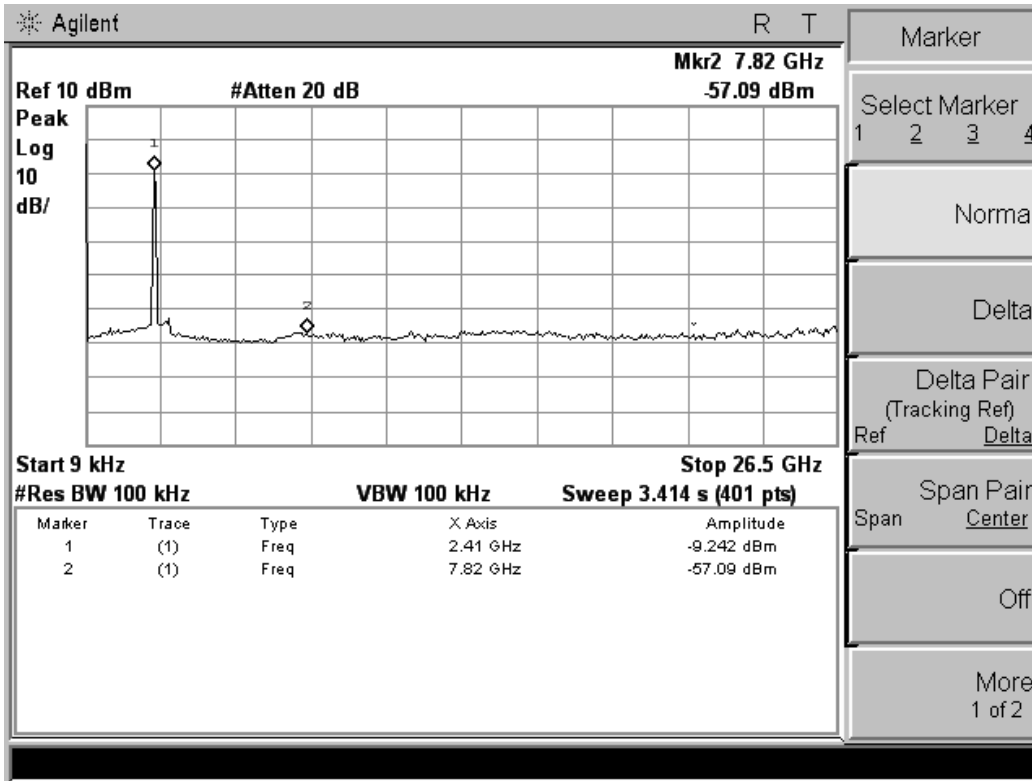

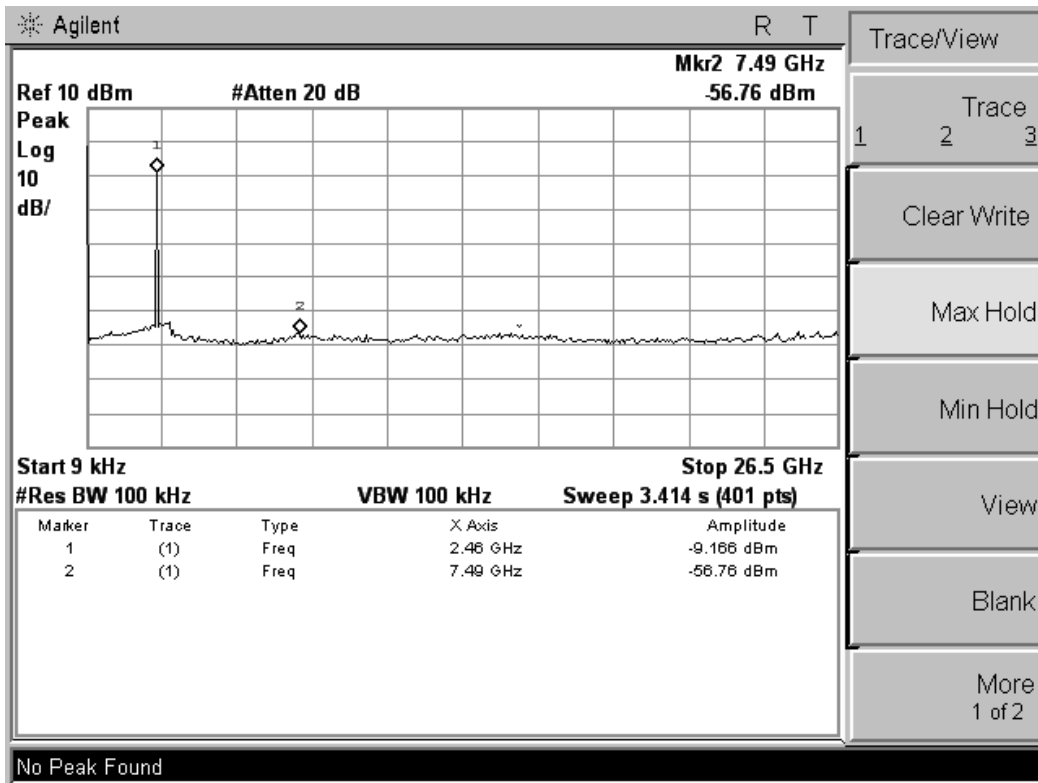

802.11g/Port.1

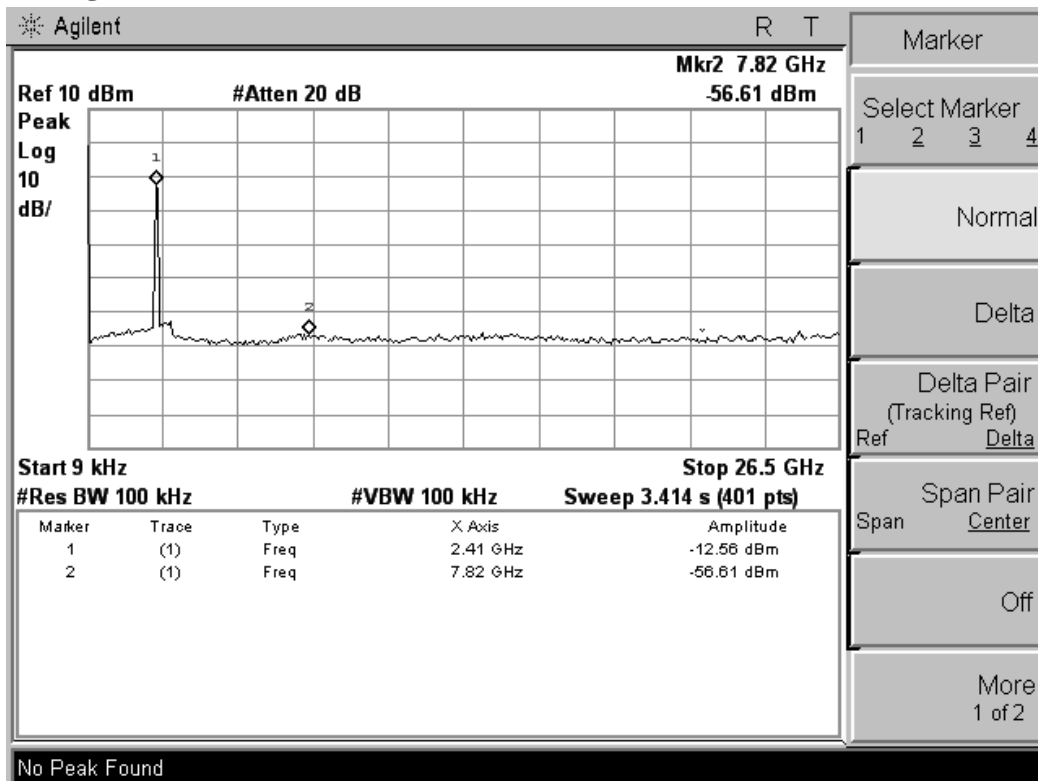

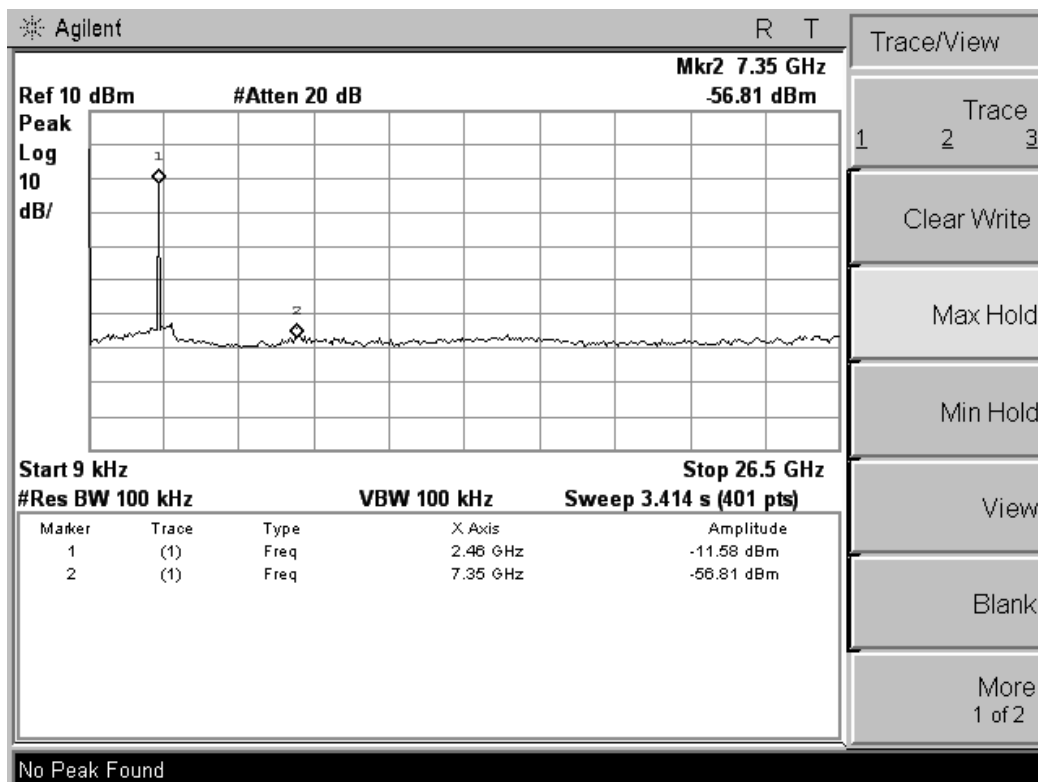
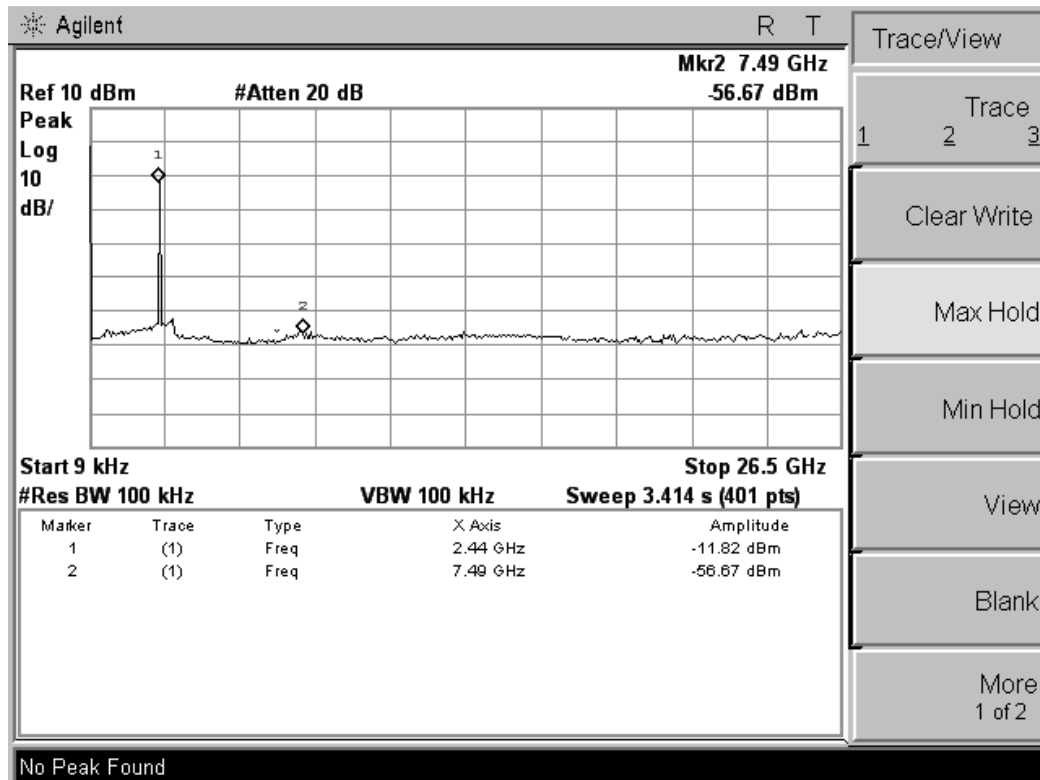

802.11n HT20/Port.1+Port.2

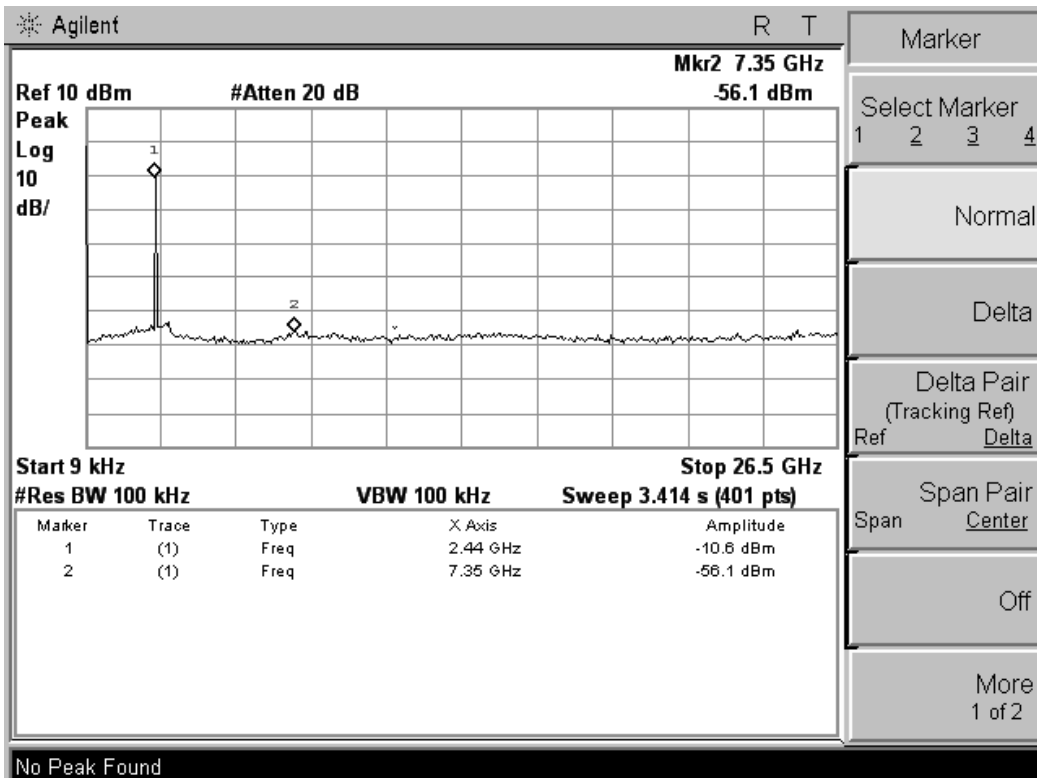
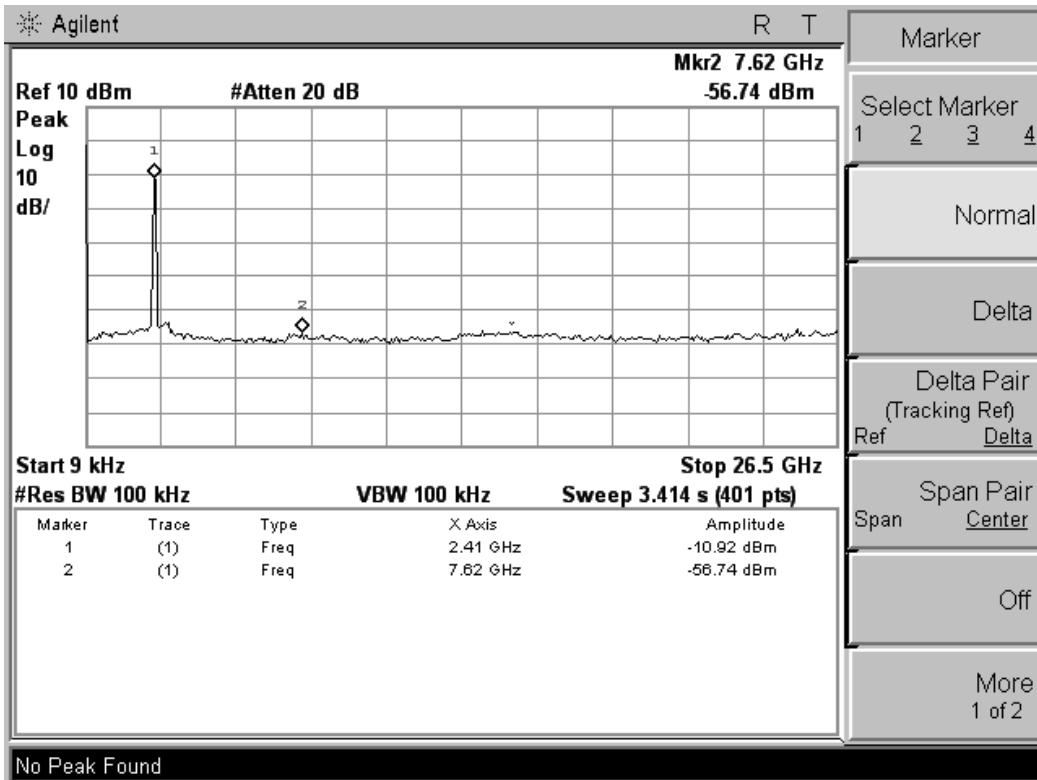

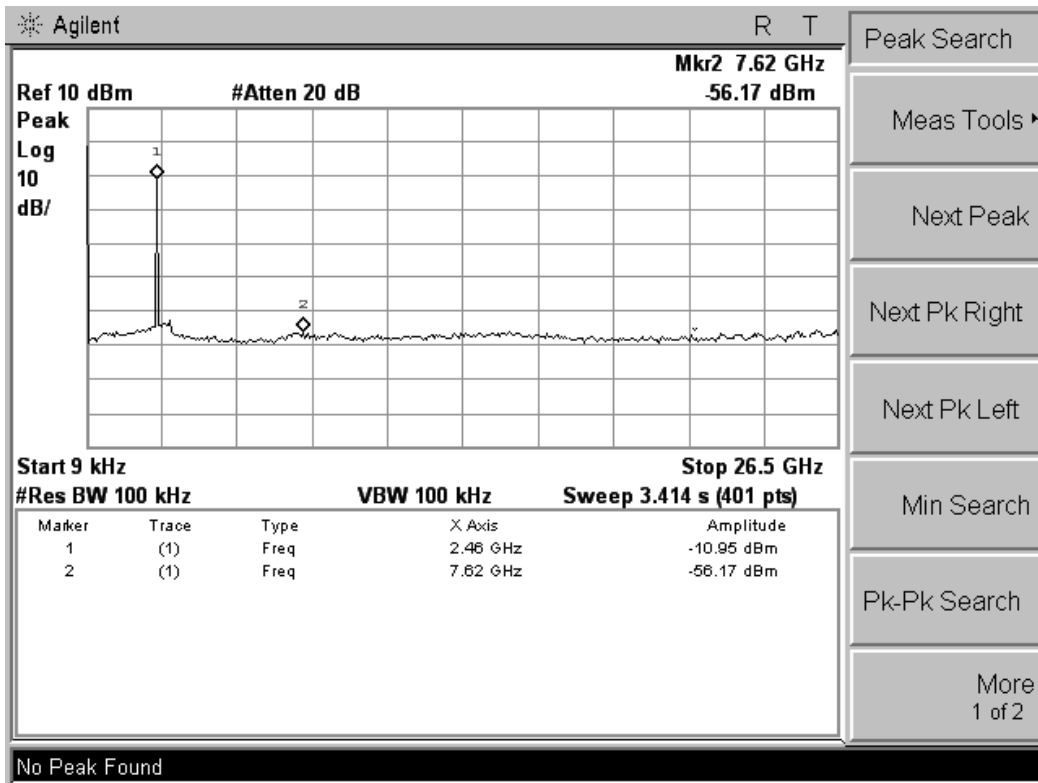

802.11n HT40/Port.1+Port.2

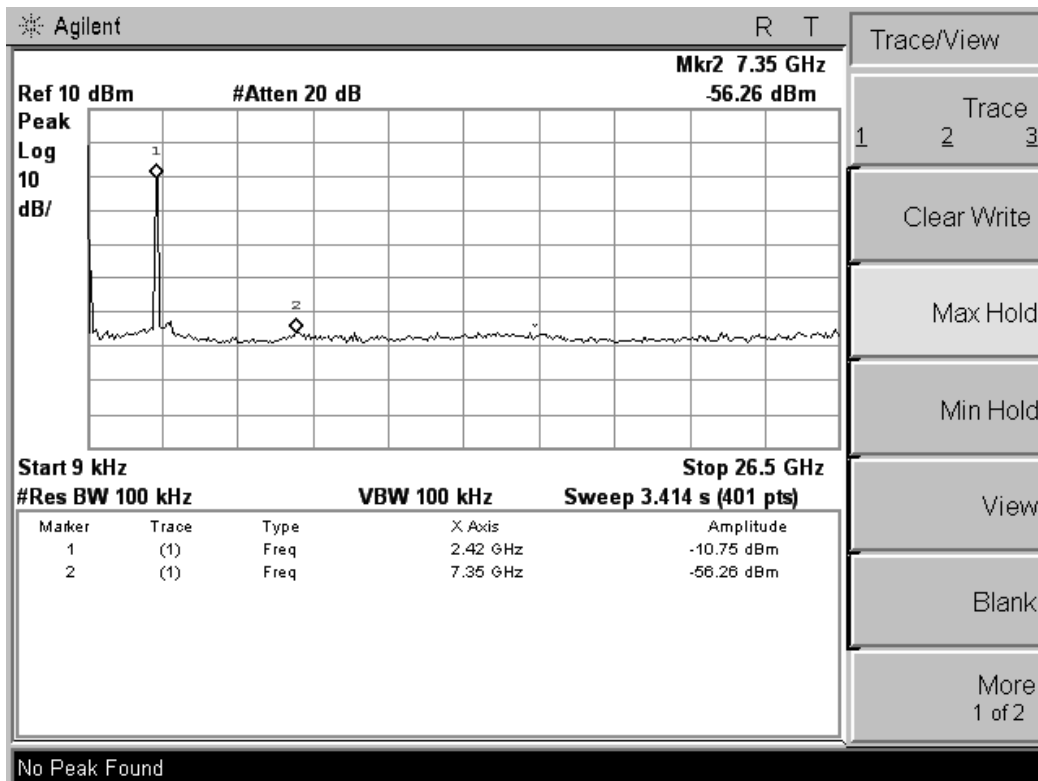

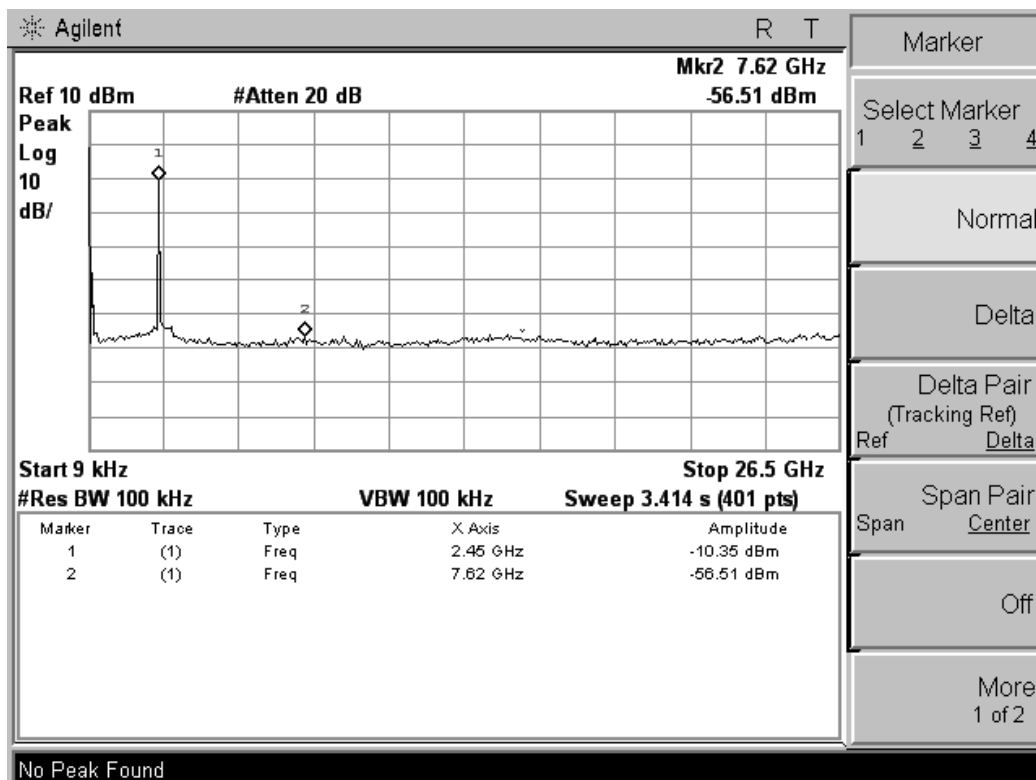
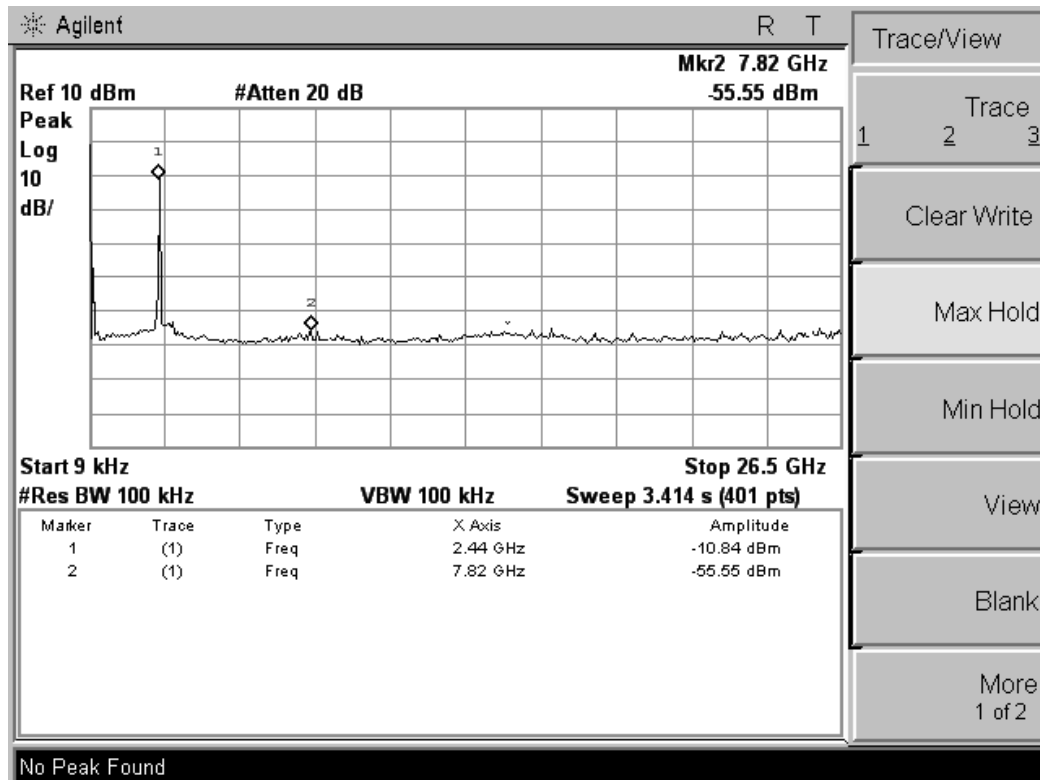

**For 5GHz Band:
802.11n HT20/Port.1+Port.2**

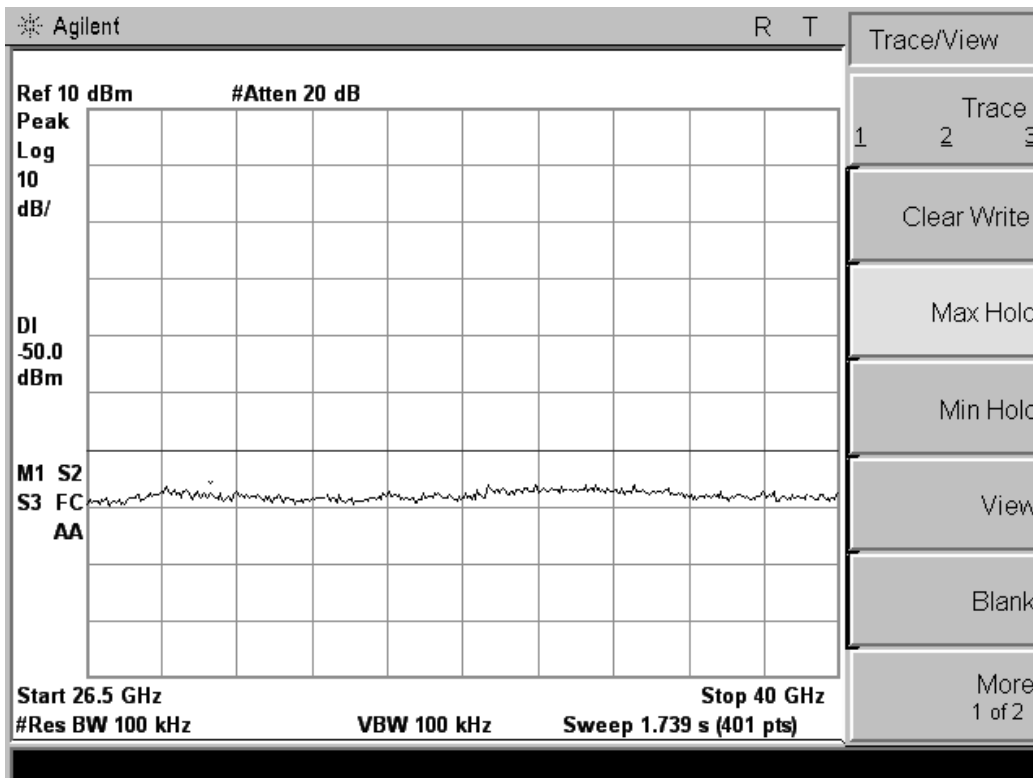
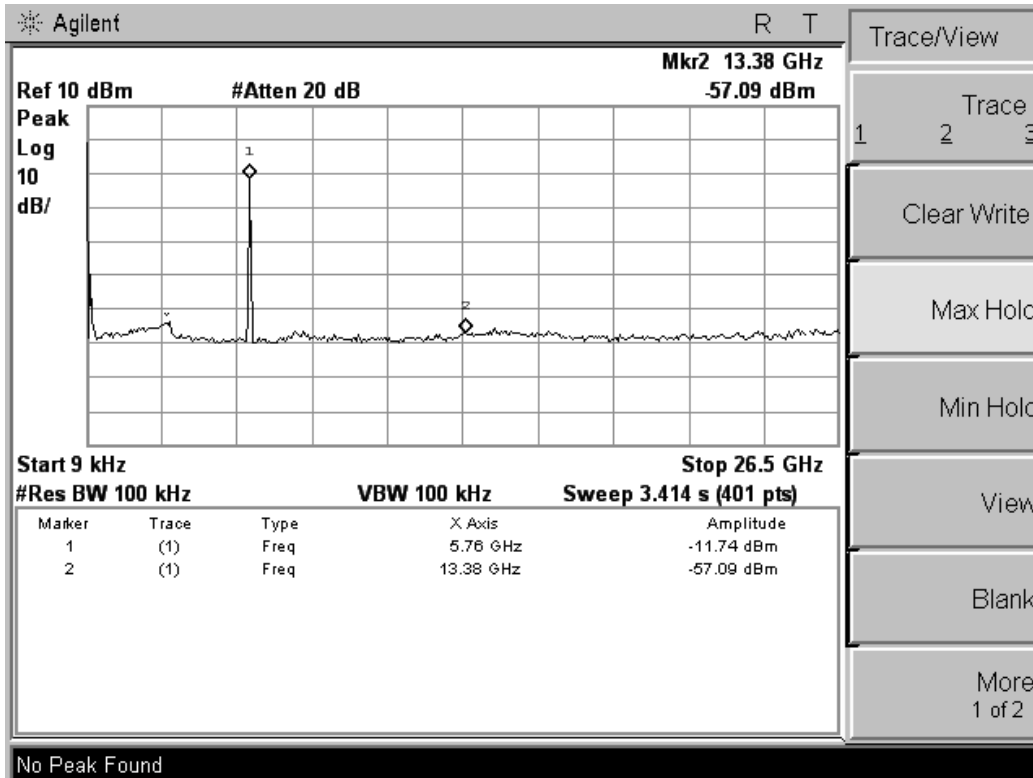

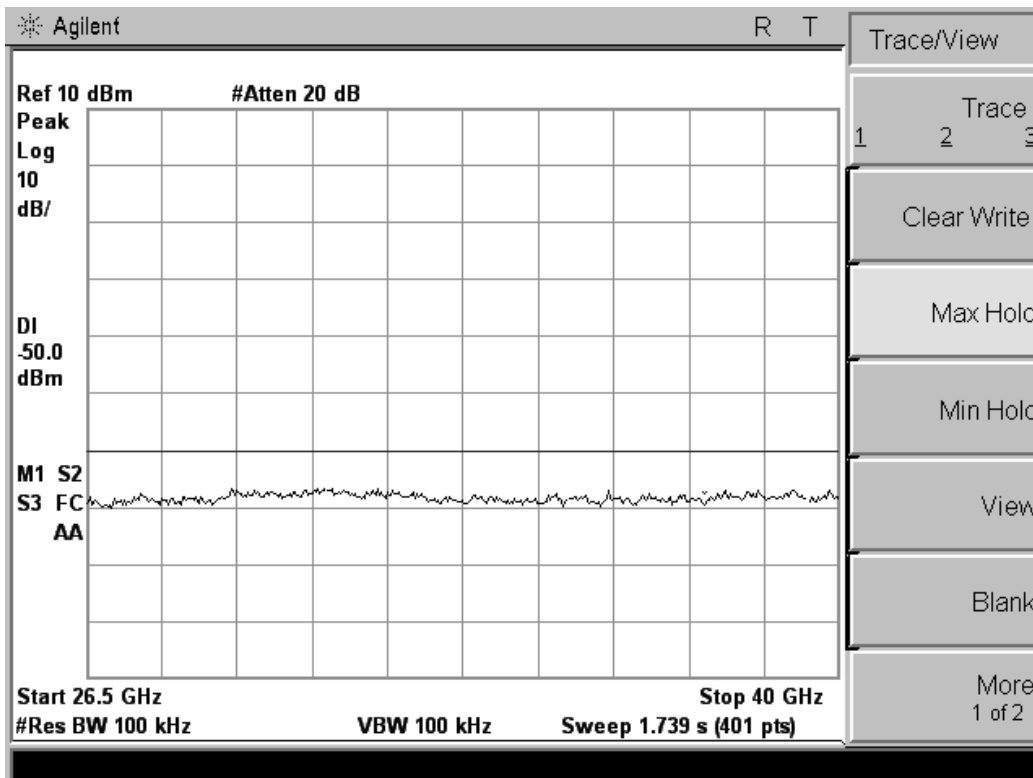
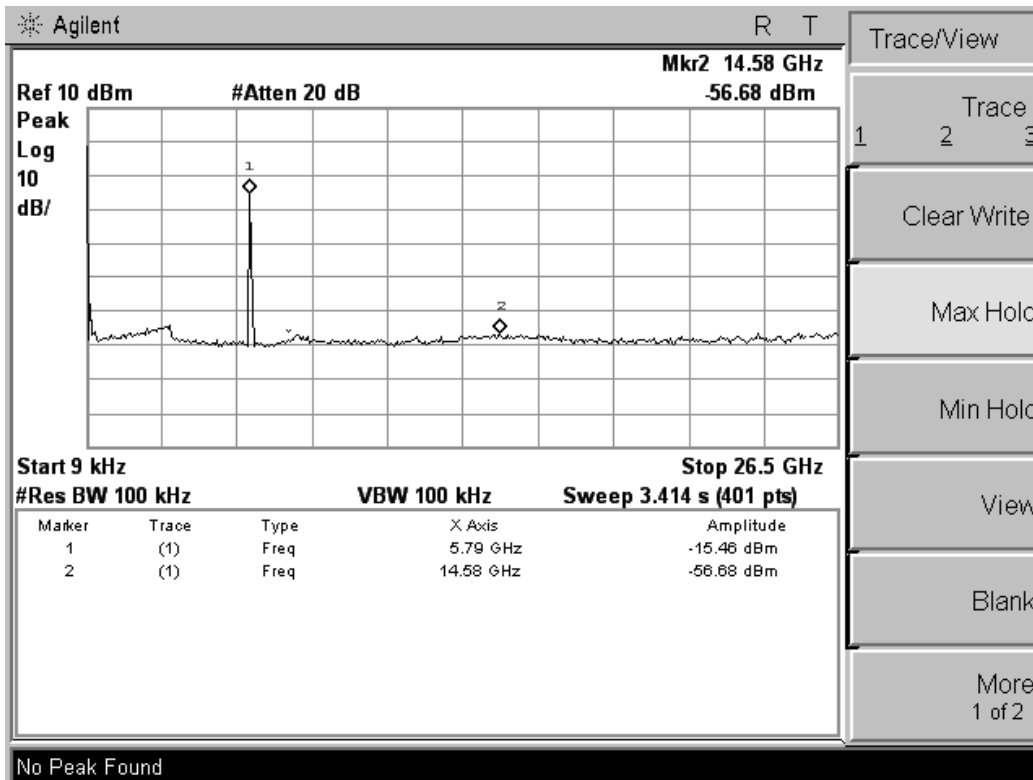

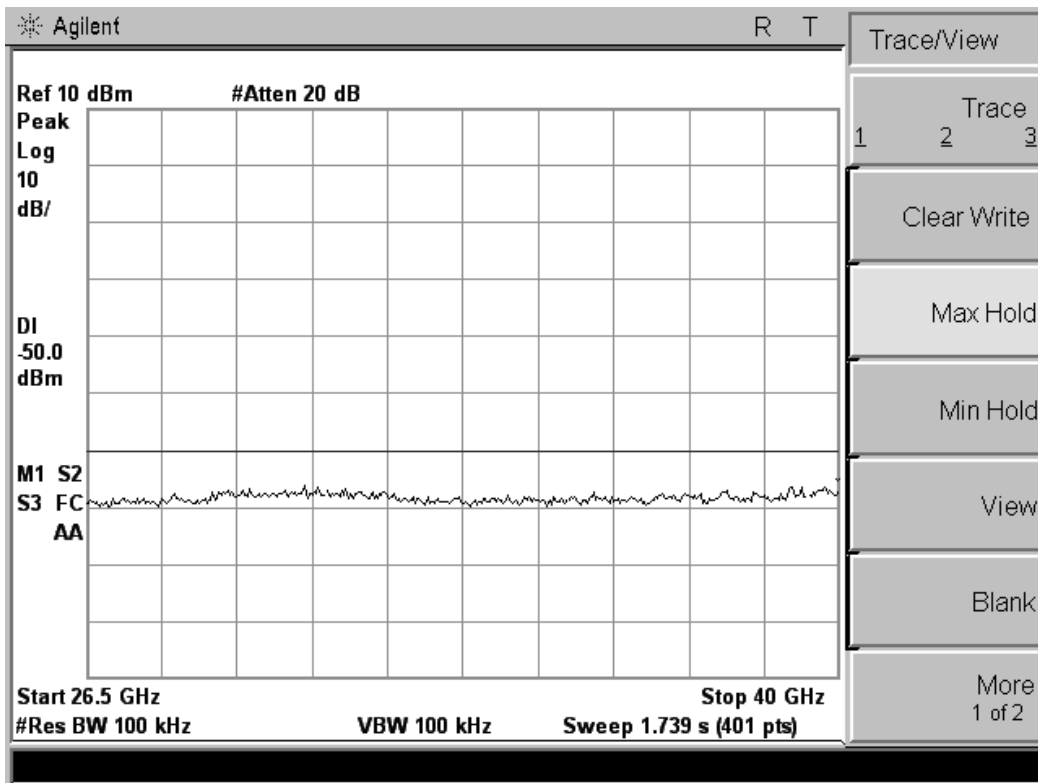
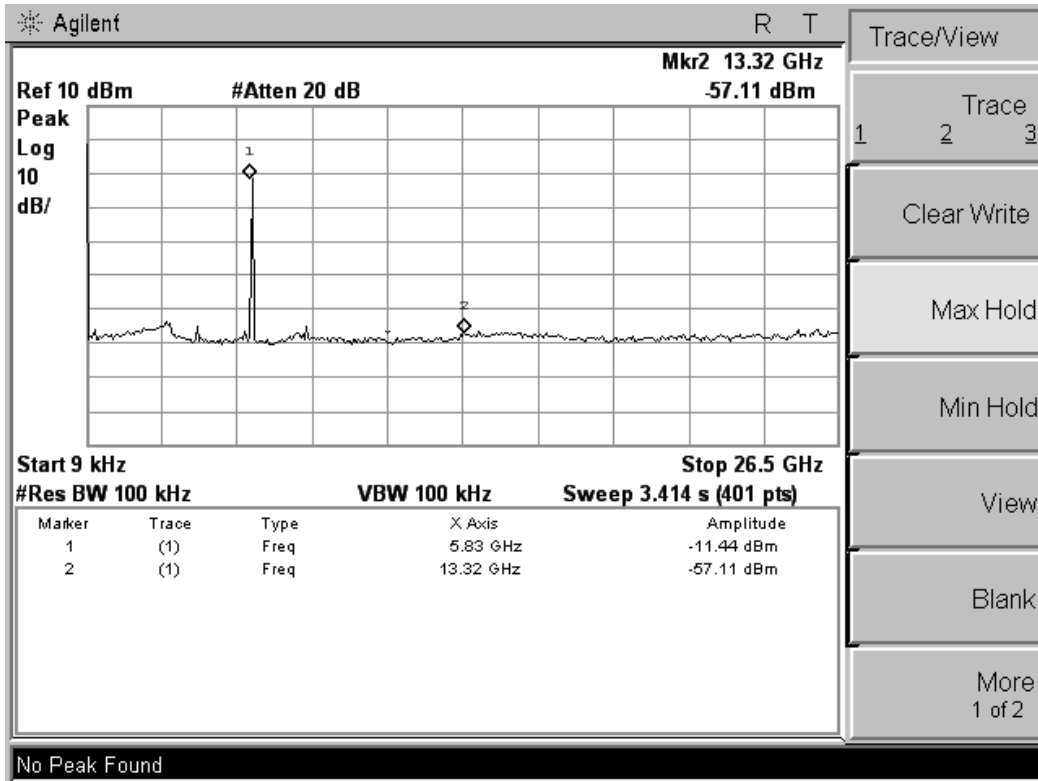

802.11n HT40/Port.1+Port.2

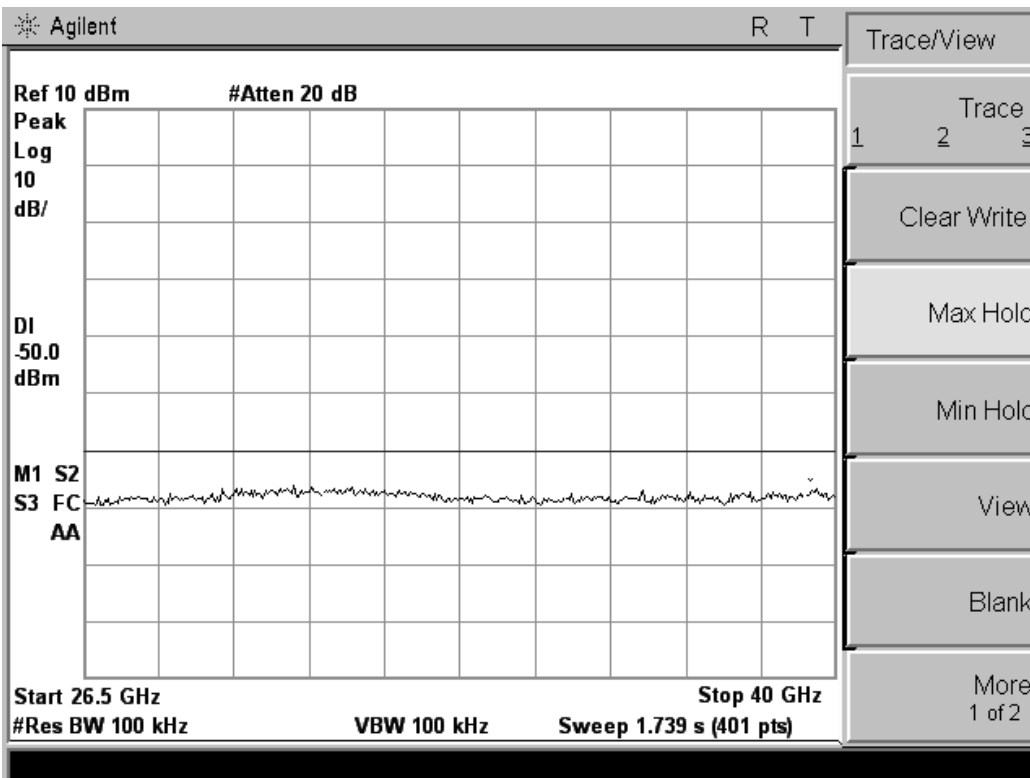
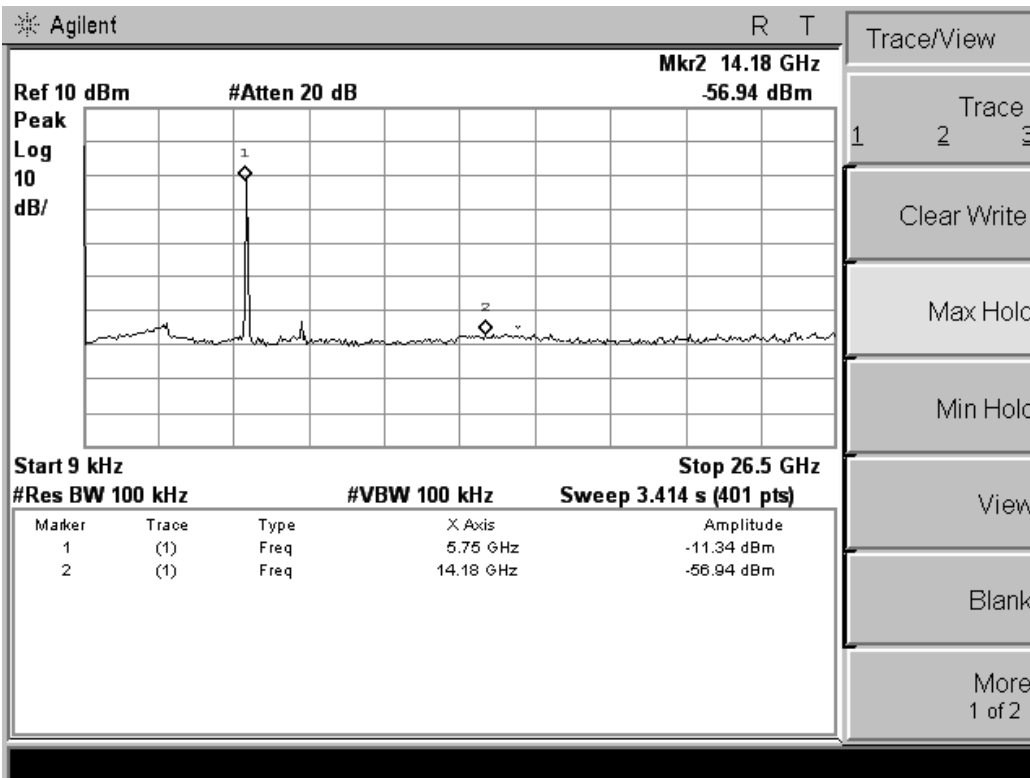

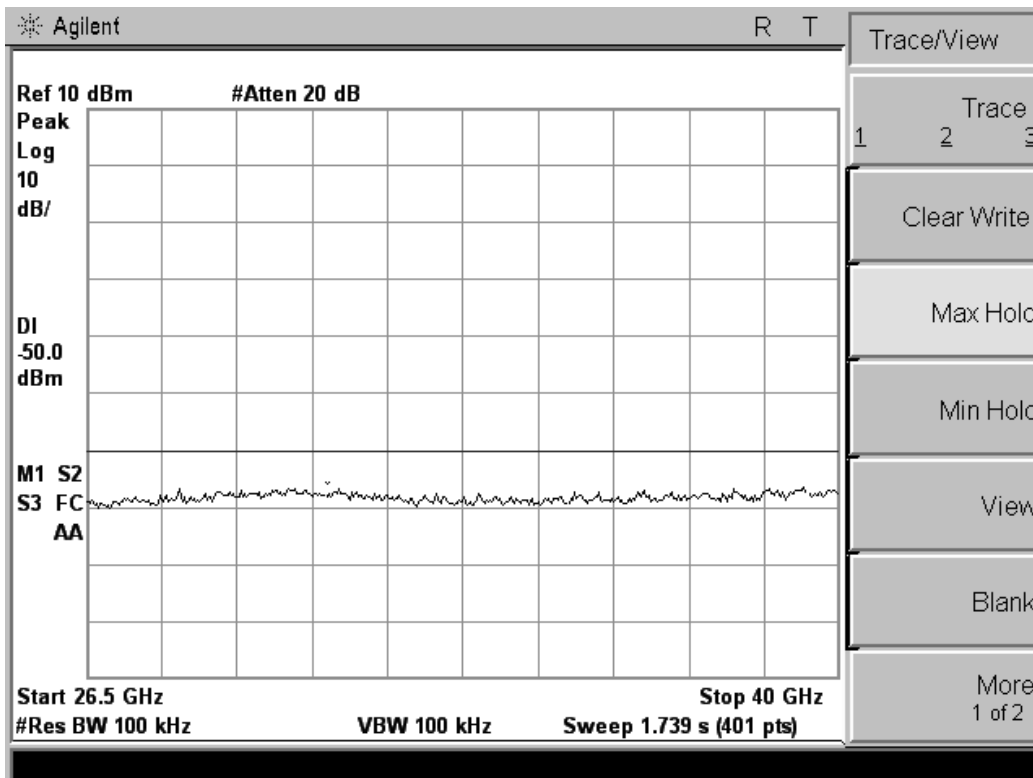
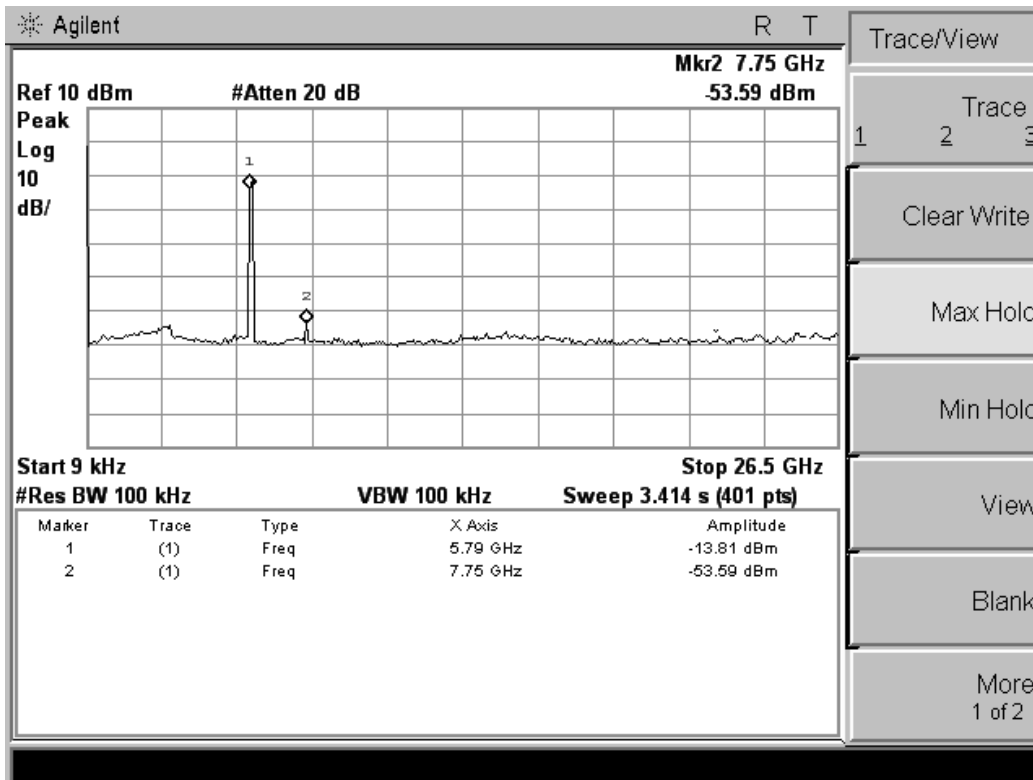

802.11a/Port.1

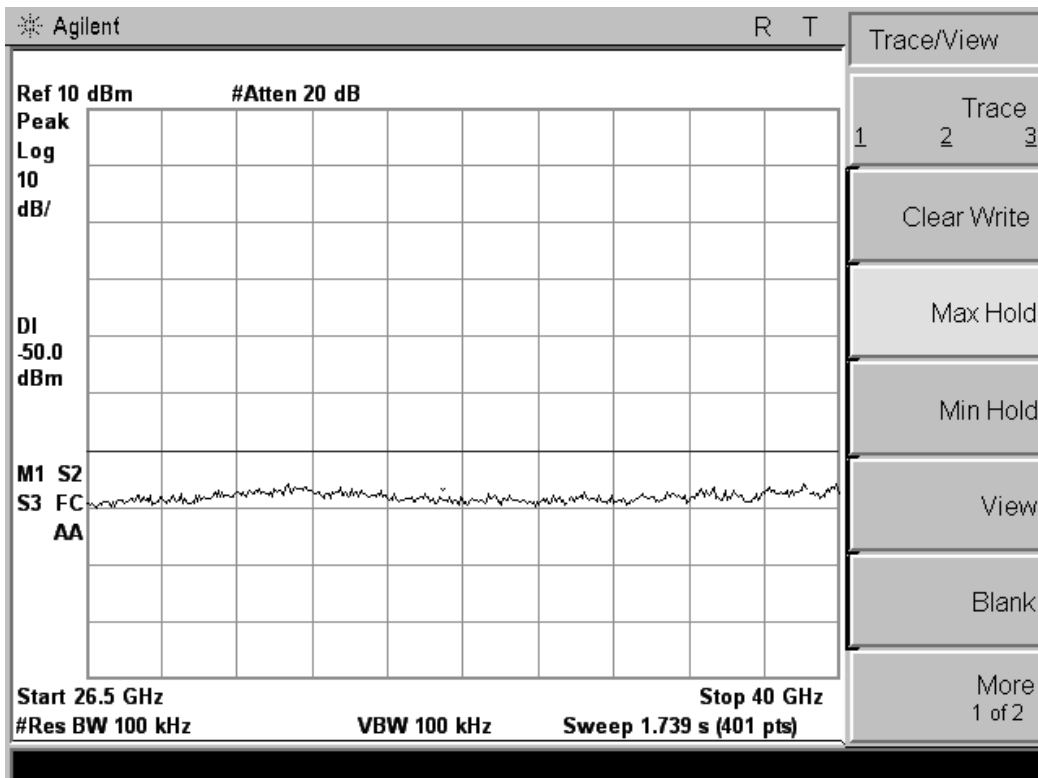
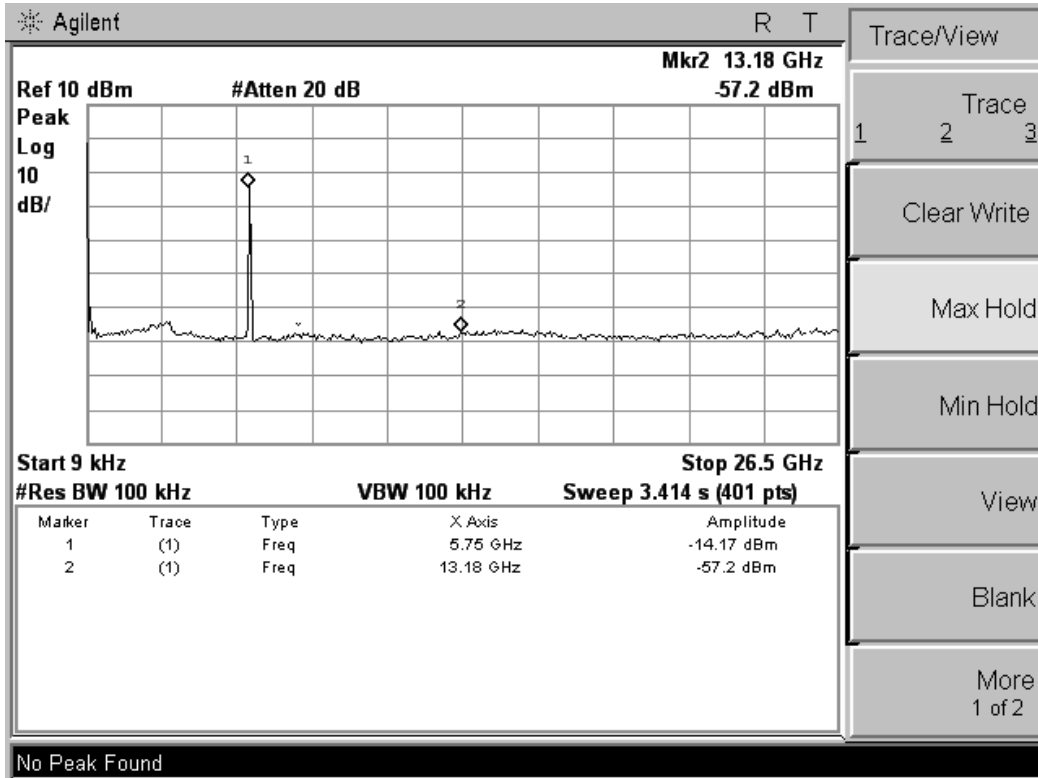

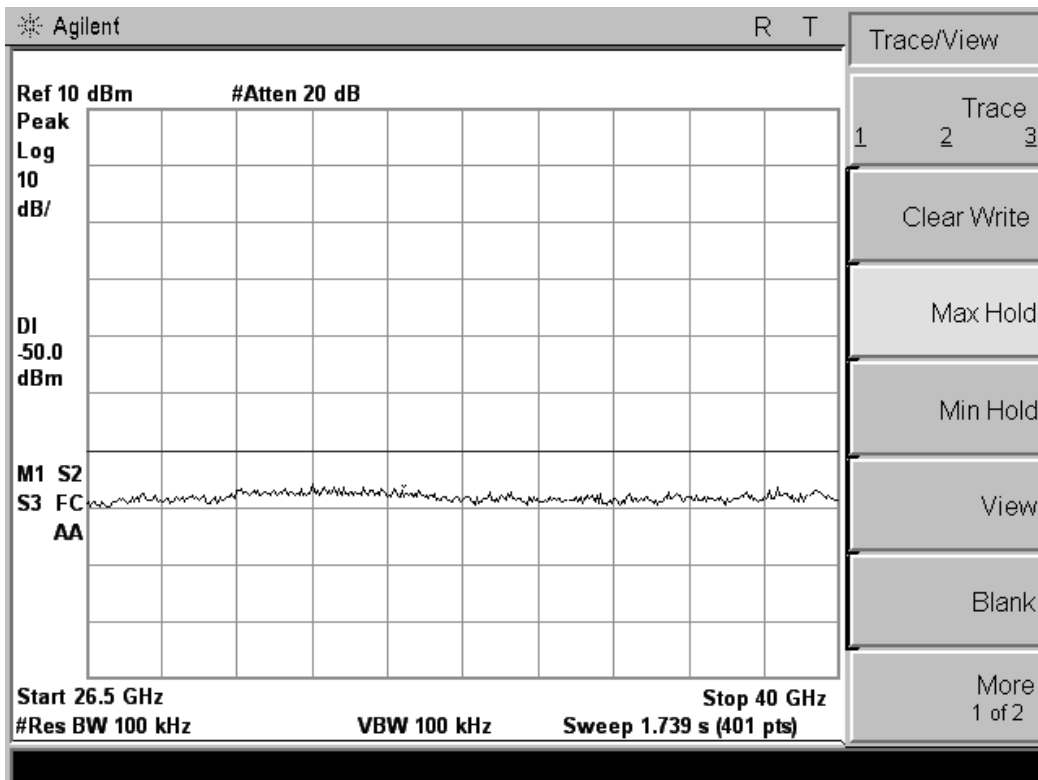
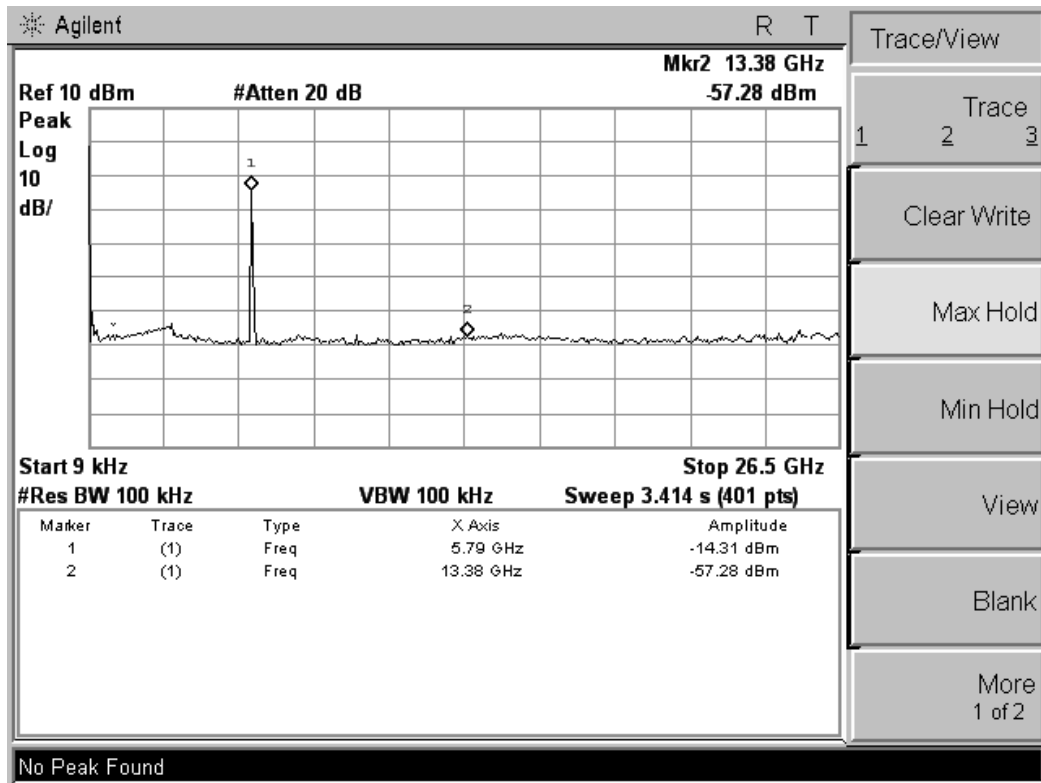

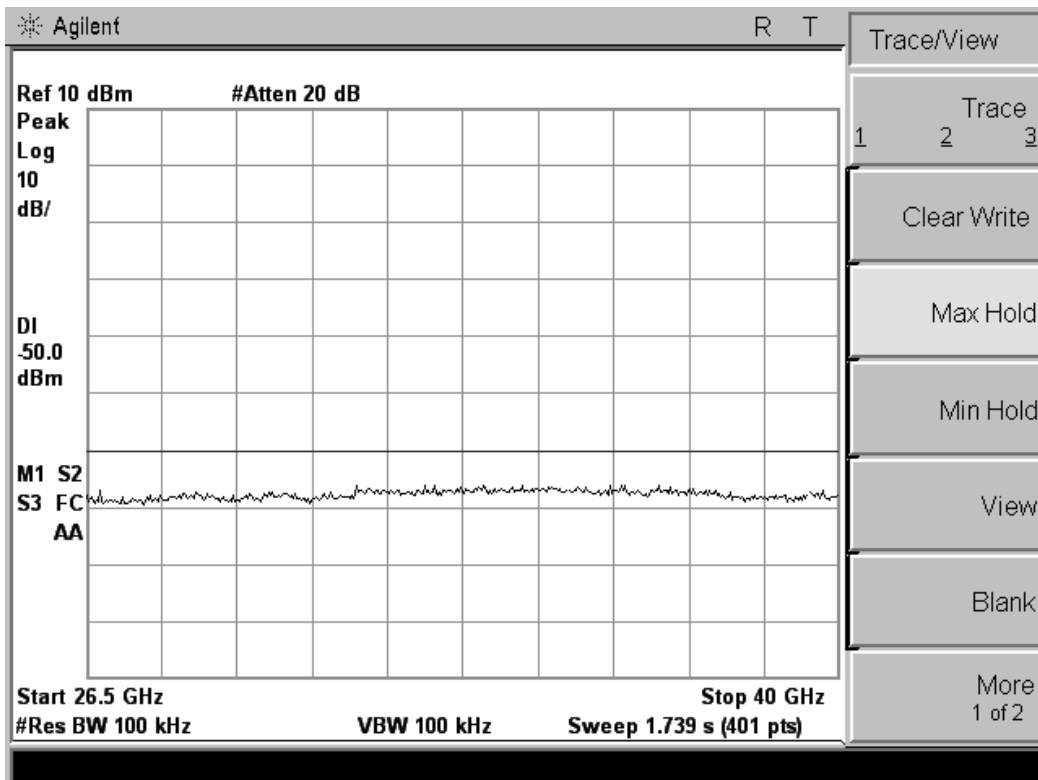
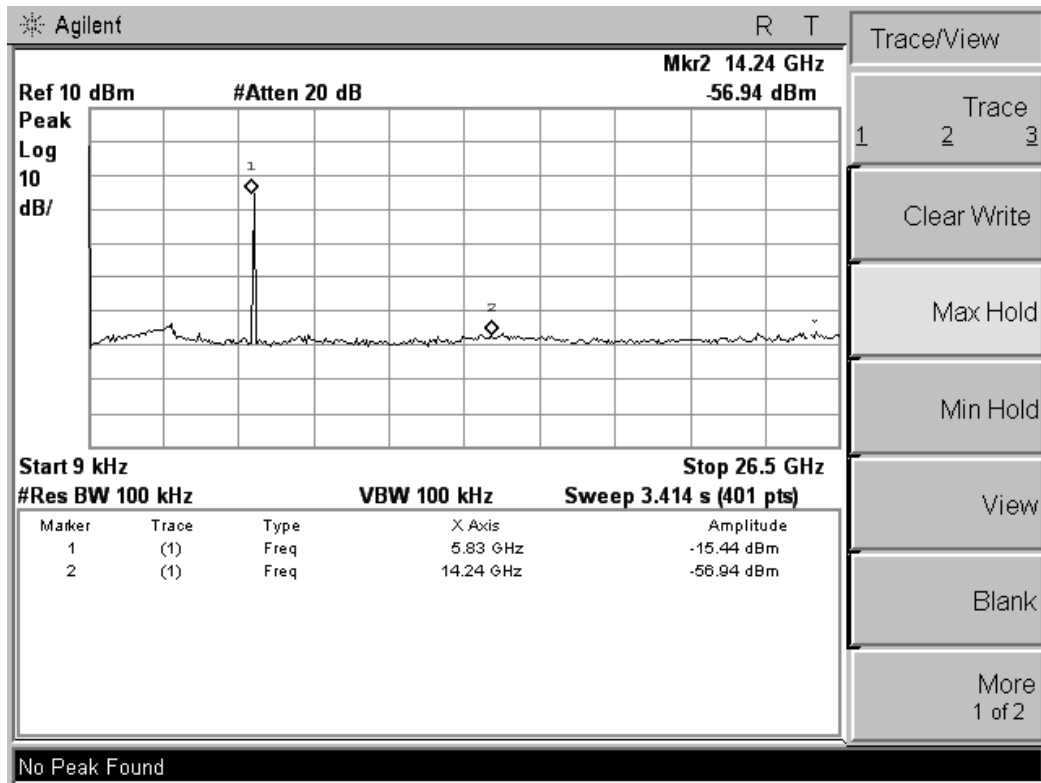

5.6.7. Test Results of Band Edges Test

For 2.4GHz Band:

802.11b/Port.1

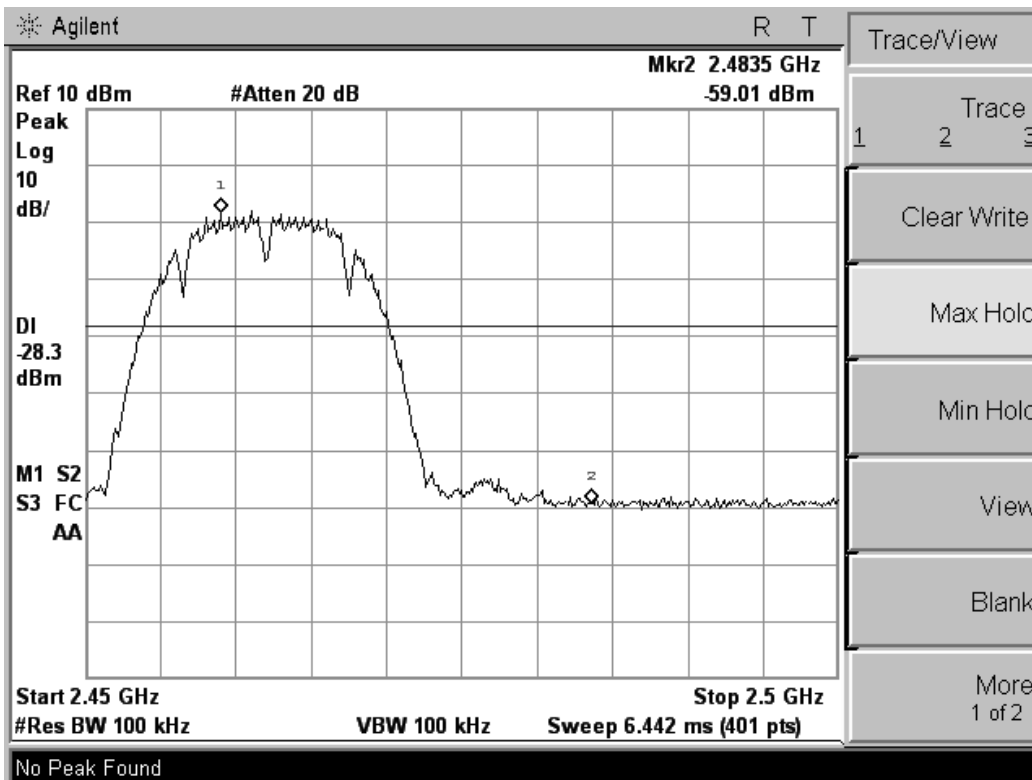
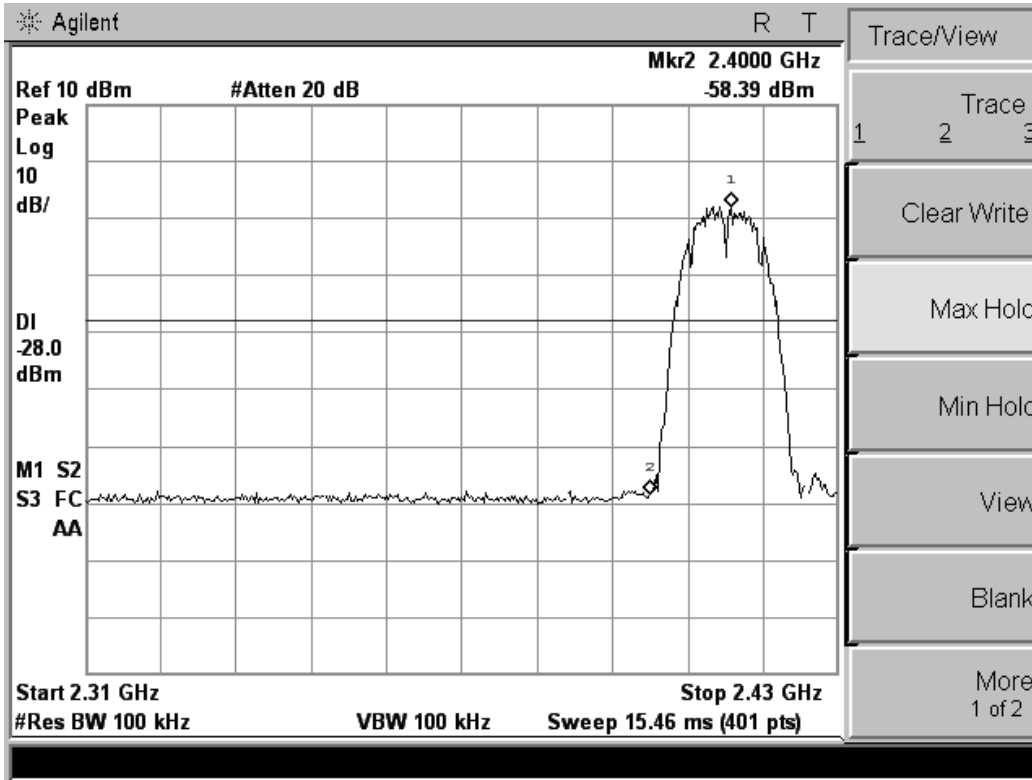

802.11g/Port.1

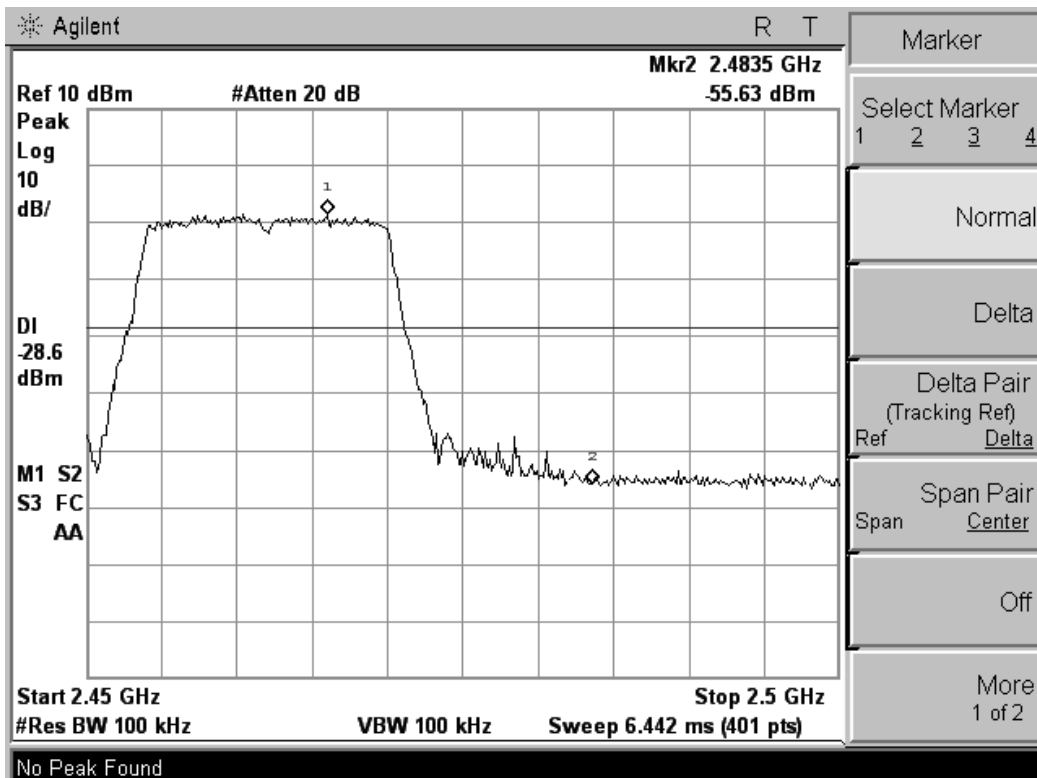
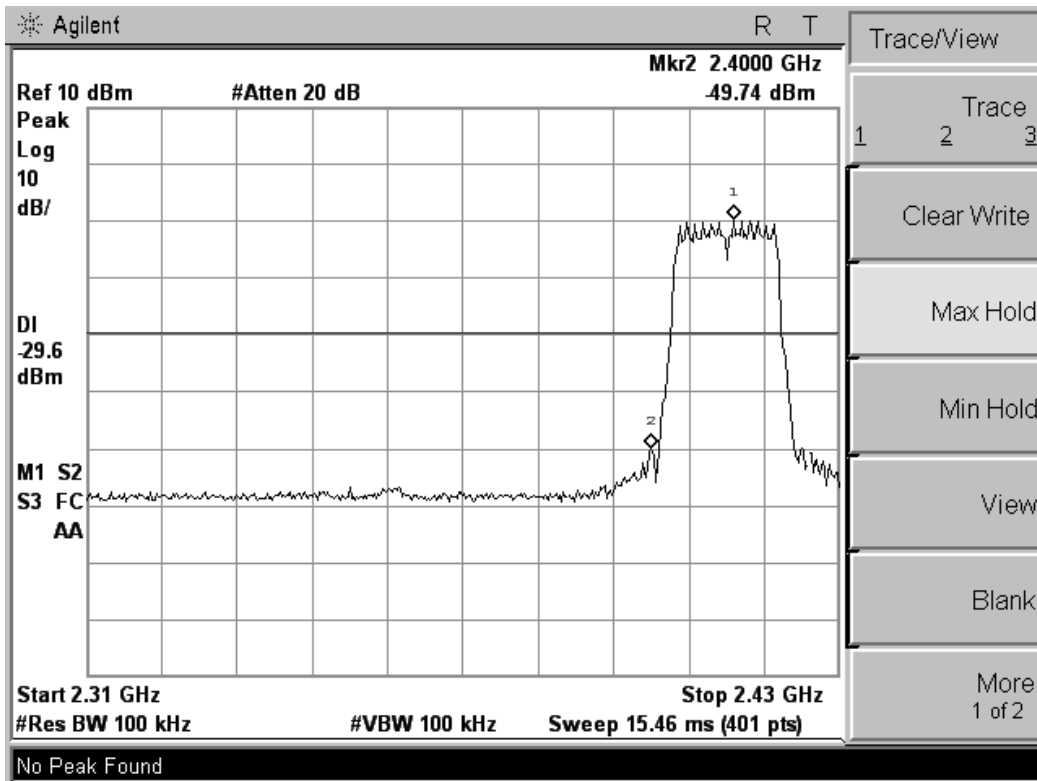

802.11n HT20/Port.1+Port.2

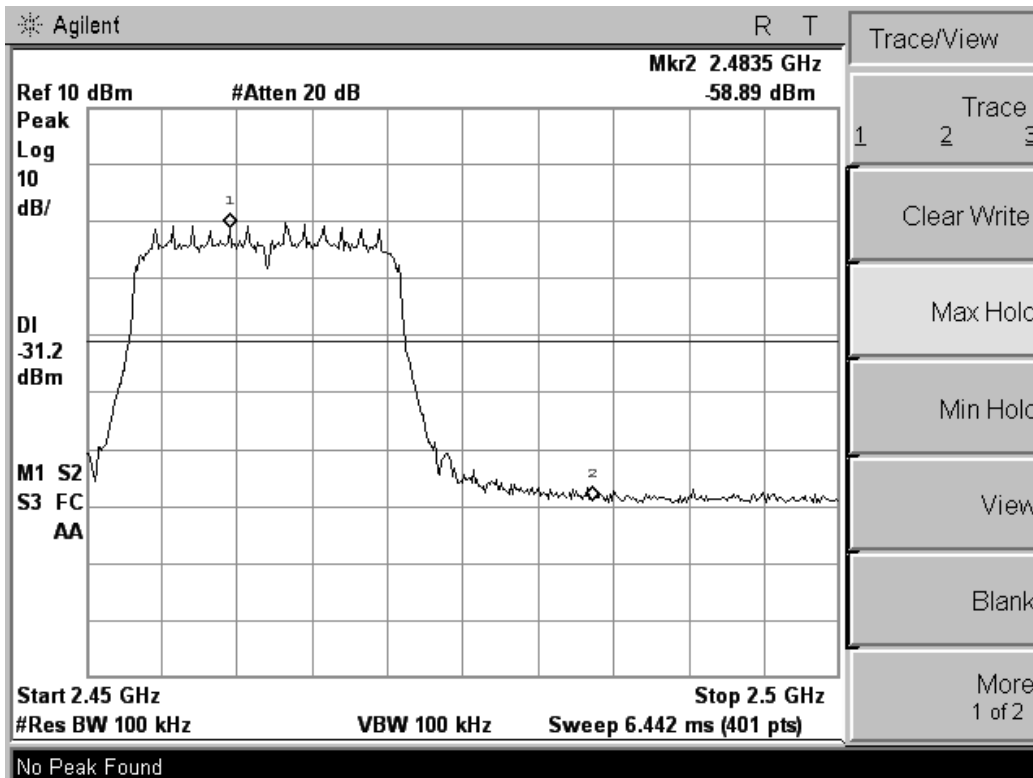
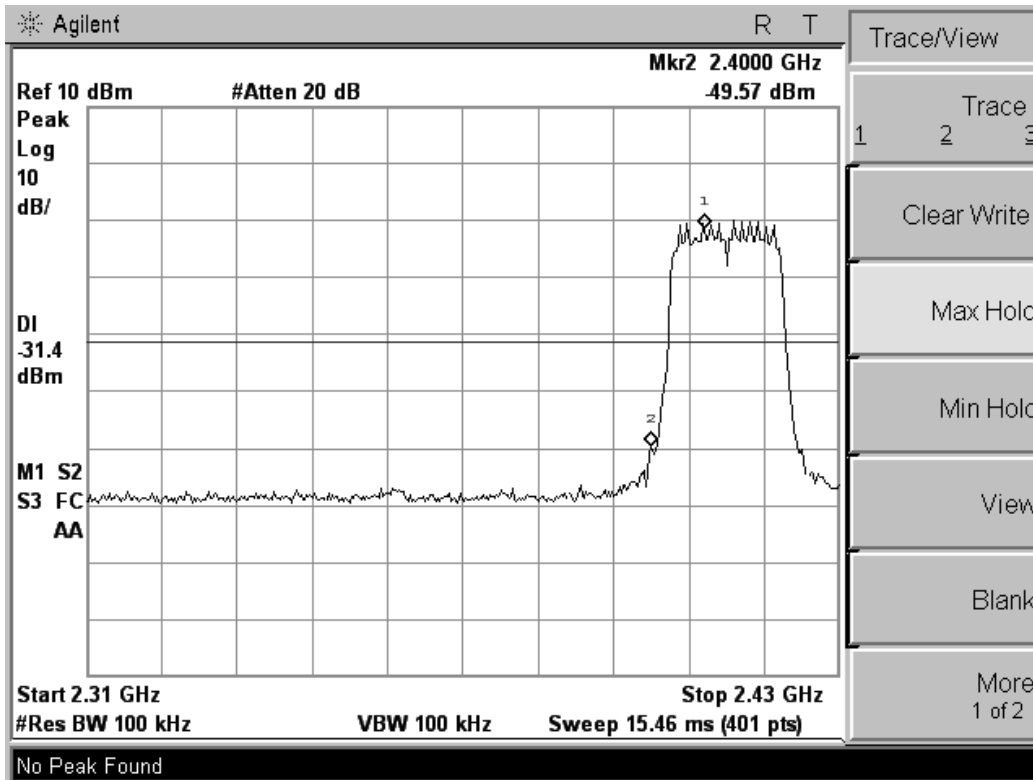

802.11n HT40/Port.1+Port.2

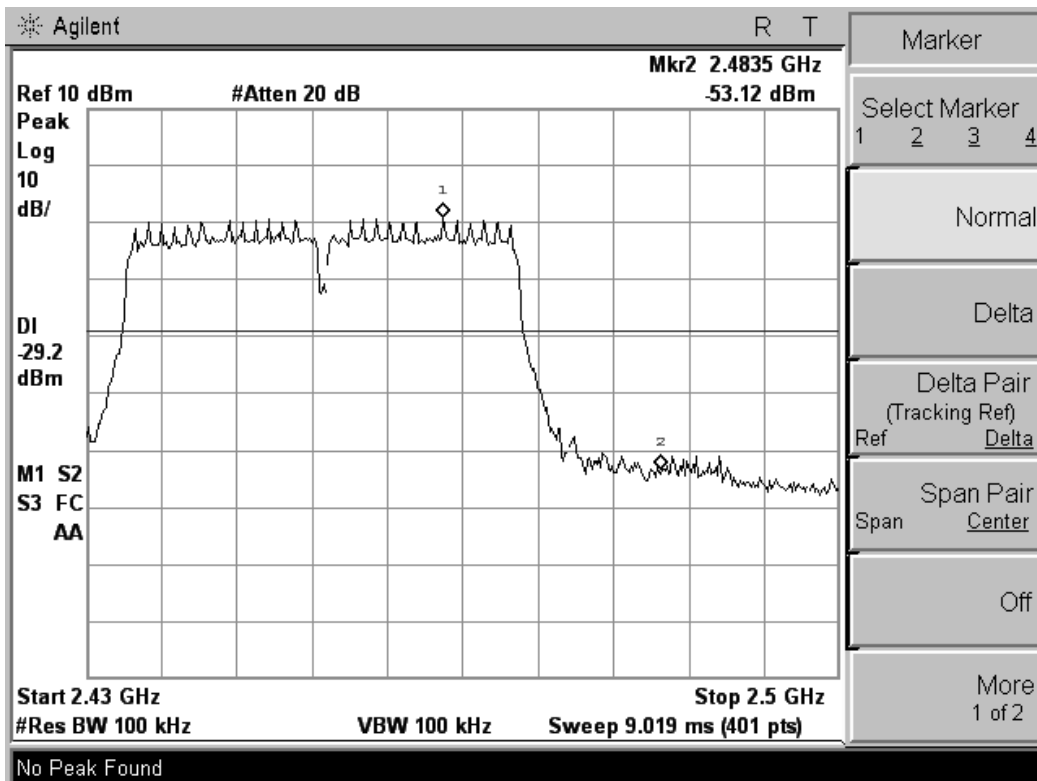
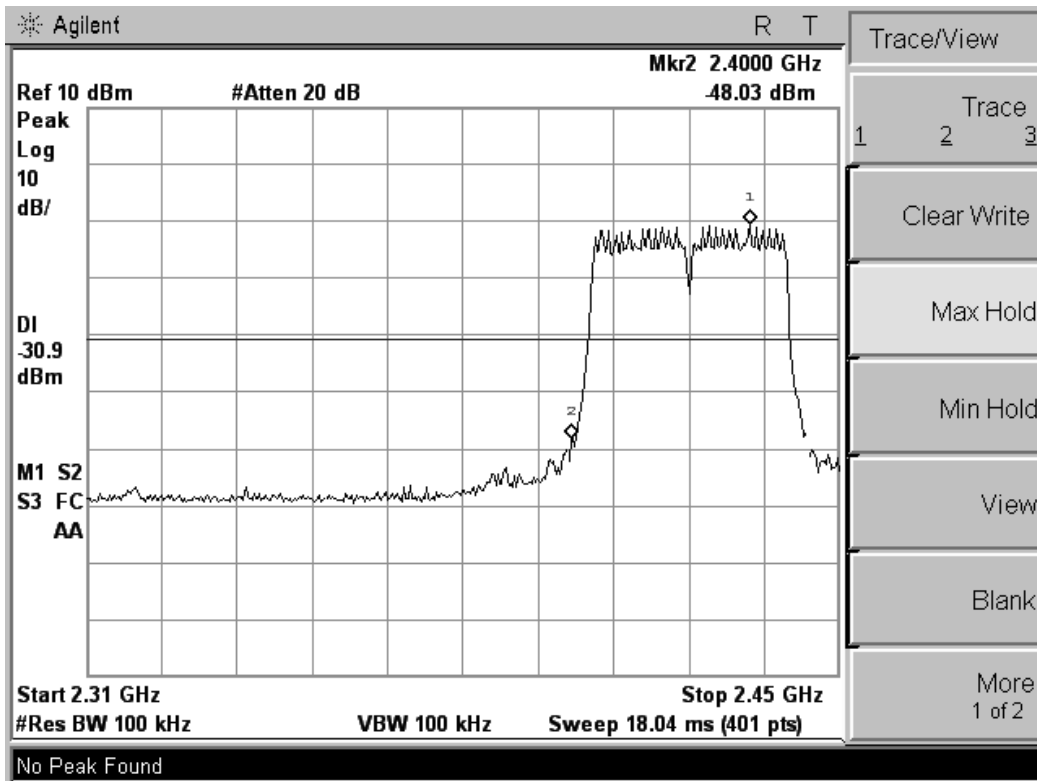

For 5GHz Band:

802.11n HT20/Port.1+Port.2

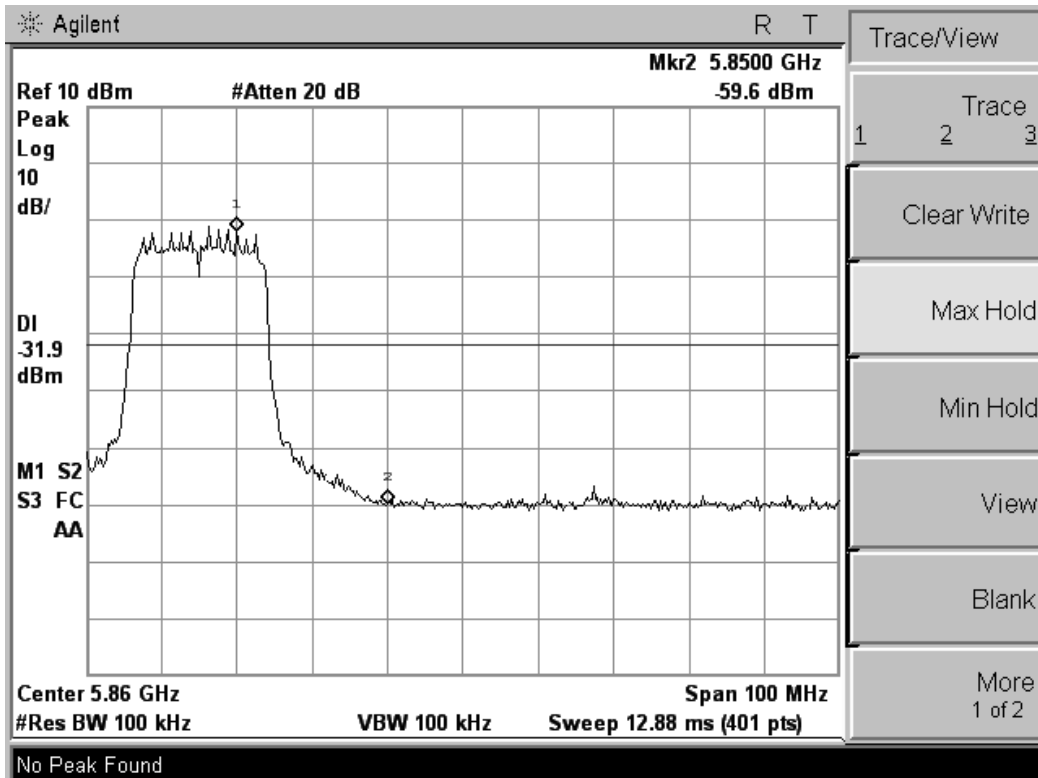
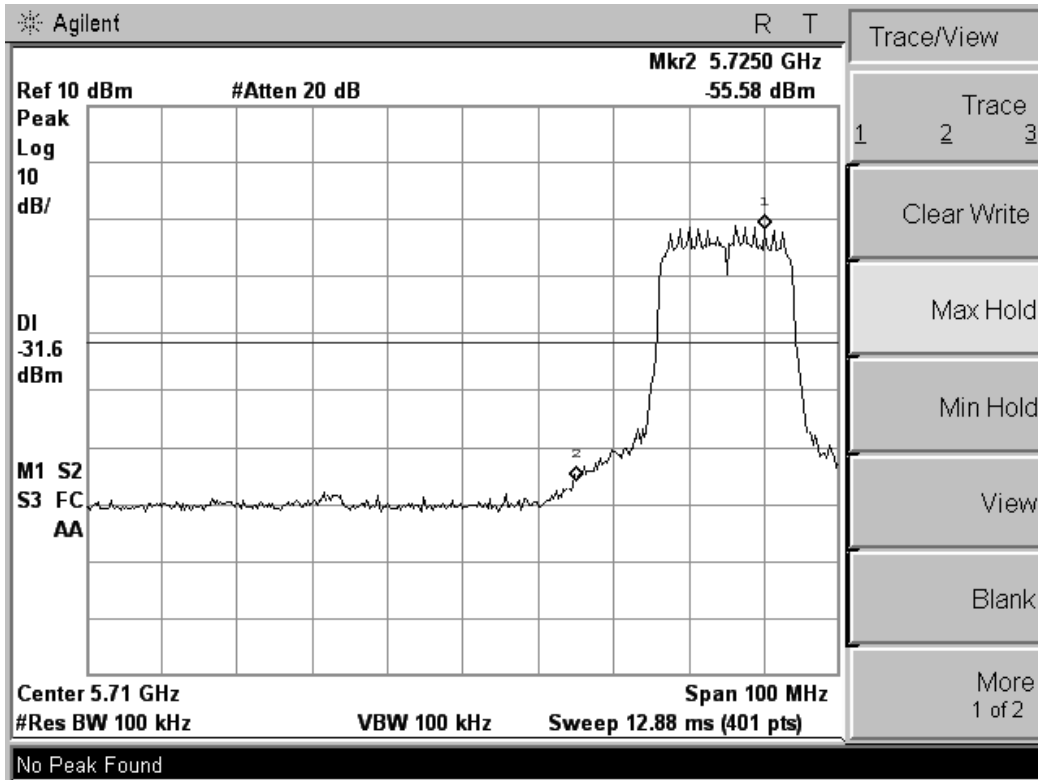

802.11n HT40/Port.1+Port.2

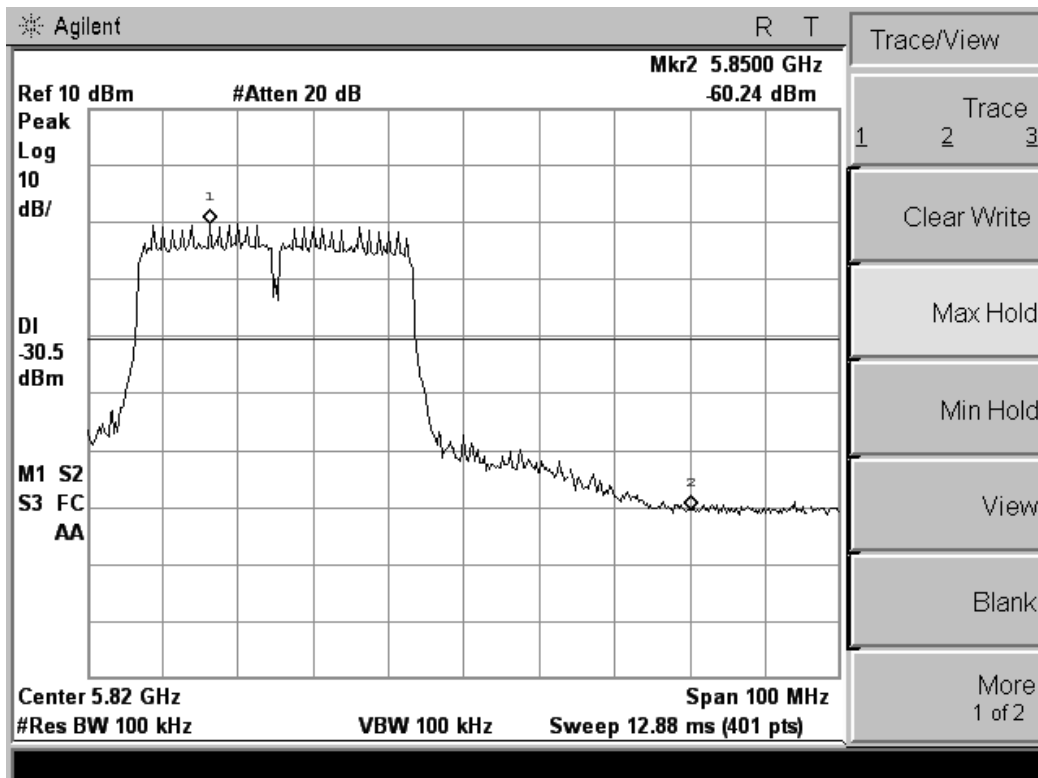
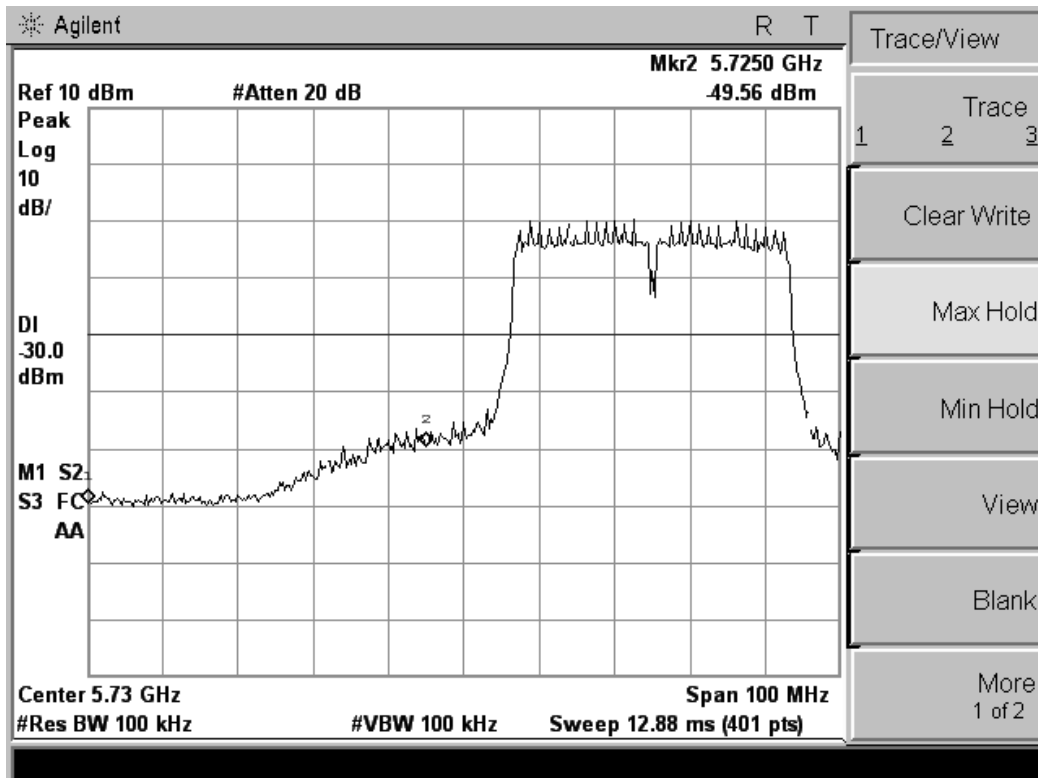

802.11a/Port.1

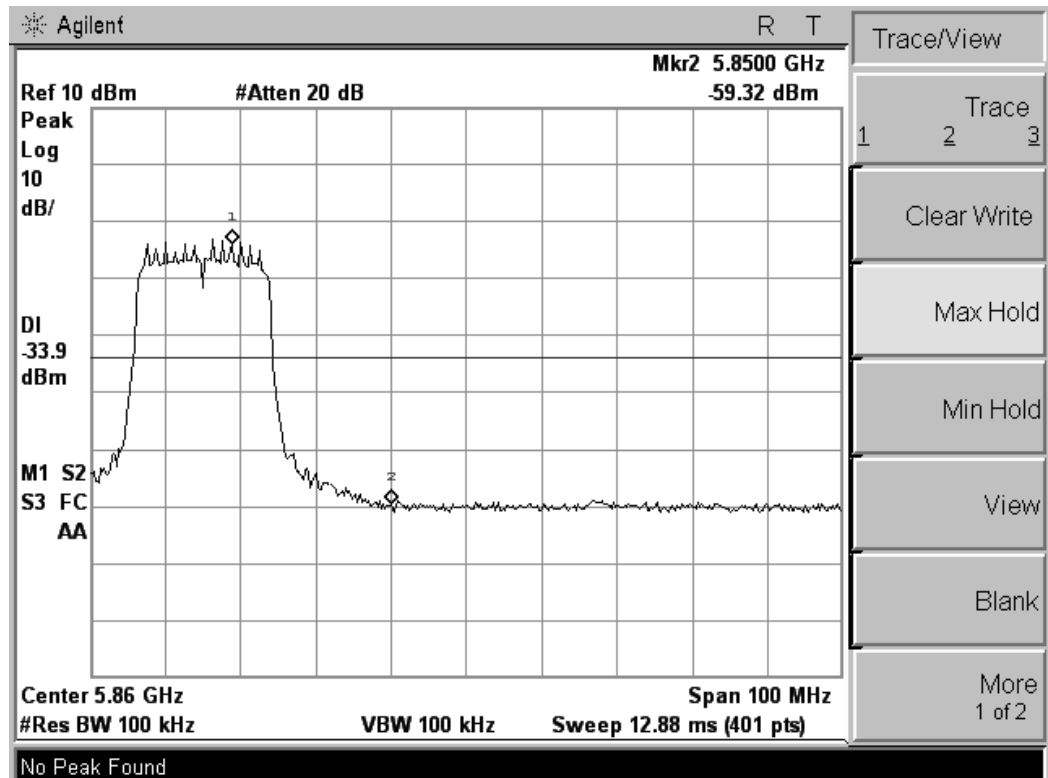
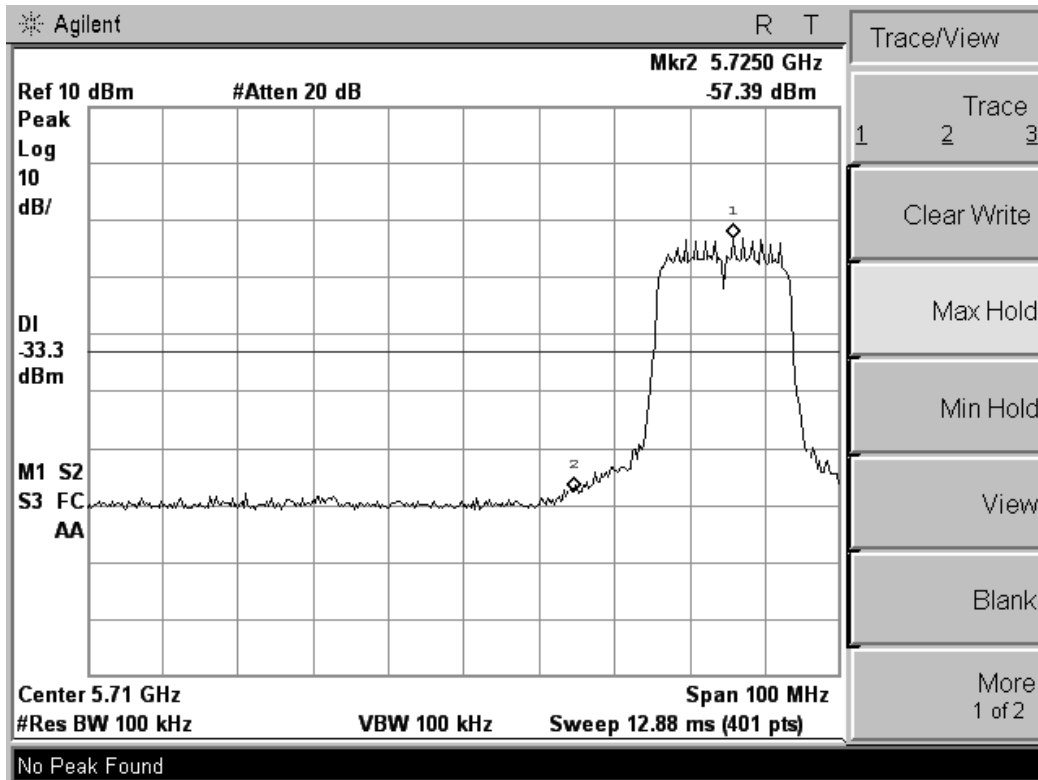

5.7. Power line conducted emissions

5.7.1 Standard Applicable

According to §15.207 (a): For an intentional radiator which is designed to be connected to the public utility (AC) power line, the radio frequency voltage that is conducted back onto the AC power line on any frequency or frequencies within the band 150 kHz to 30 MHz shall not exceed 250 microvolts (The limit decreases linearly with the logarithm of the frequency in the range 0.15 MHz to 0.50 MHz). The limits at specific frequency range is listed as follows:

Frequency Range (MHz)	Limits (dB μ V)	
	Quasi-peak	Average
0.15 to 0.50	66 to 56	56 to 46
0.50 to 5	56	46
5 to 30	60	50

5.7.2 Block Diagram of Test Setup

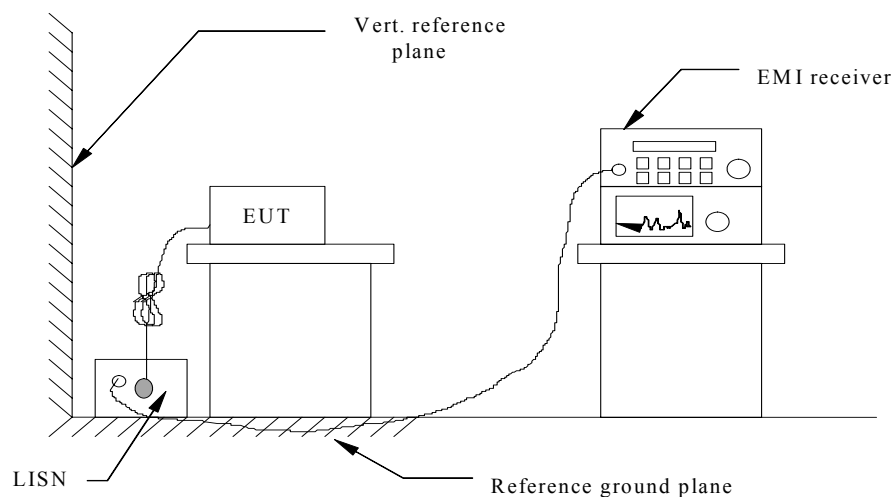

5.7.3 Test Results

PASS.

The test data please refer to following page.

Test result for 802.11n HT20 (Low Channel, 2.4GHz Band)

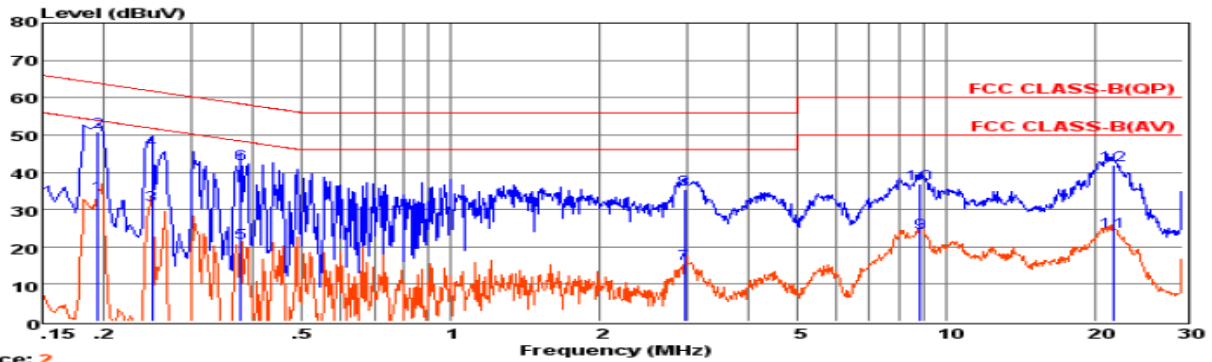

Trace: 2
 Env. Ins: 24*/56%
 EUT: 300Mbps 802.11n/a/b/g Wireless Dual Band USB Adapter
 M/N: RNX-N600UBE
 Power Rating: AC 120V/60Hz
 Test Mode: Tx-2412(802.11n20,2.4G)
 Operator: Andy
 Memo:
 Pol: LINE

Freq	Reading	LisnFac	CabLos	Measured	Limit	Over	Remark	
MHz	dBpW	dB	dB	dBpW	dBpW	dB		
1	0.19	24.36	9.62	0.02	34.00	53.84	-19.84	Average
2	0.19	41.33	9.62	0.02	50.97	63.84	-12.87	QP
3	0.25	21.49	9.63	0.03	31.15	51.78	-20.63	Average
4	0.25	36.54	9.63	0.03	46.20	61.78	-15.58	QP
5	0.38	11.44	9.62	0.04	21.10	48.34	-27.24	Average
6	0.38	32.45	9.62	0.04	42.11	58.34	-16.23	QP
7	2.96	5.77	9.64	0.06	15.47	46.00	-30.53	Average
8	2.96	25.74	9.64	0.06	35.44	56.00	-20.56	QP
9	8.87	14.12	9.69	0.08	23.89	50.00	-26.11	Average
10	8.87	27.04	9.69	0.08	36.81	60.00	-23.19	QP
11	21.71	14.18	9.72	0.12	24.02	50.00	-25.98	Average
12	21.71	32.03	9.72	0.12	41.87	60.00	-18.13	QP

Remarks: 1. Measured = Reading + Lisn Factor +Cable Loss.
 2. The emission levels that are 20dB below the official limit are not reported.

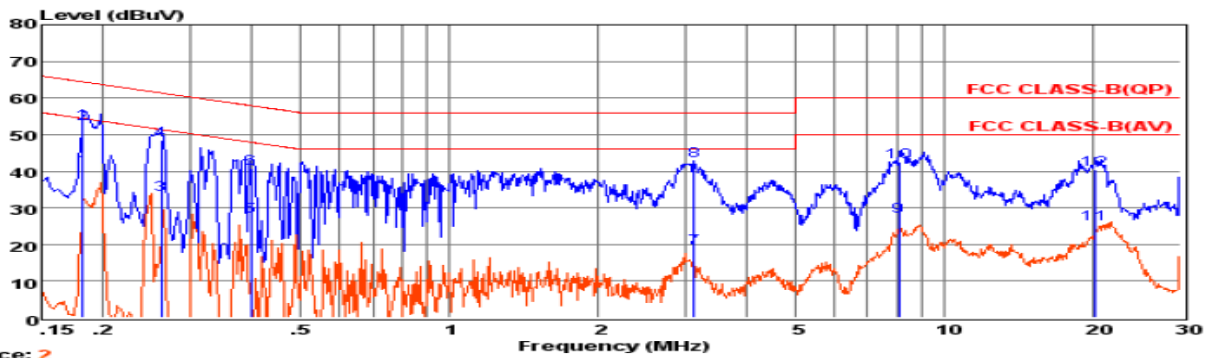

Trace: 2
 Env. Ins: 24*/56%
 EUT: 300Mbps 802.11n/a/b/g Wireless Dual Band USB Adapter
 M/N: RNX-N600UBE
 Power Rating: AC 120V/60Hz
 Test Mode: Tx-2412(802.11n20,2.4G)
 Operator: Andy
 Memo:
 Pol: NEUTRAL

Freq	Reading	LisnFac	CabLos	Measured	Limit	Over	Remark	
MHz	dBpW	dB	dB	dBpW	dBpW	dB		
1	0.18	31.17	9.63	0.02	40.82	54.42	-13.60	Average
2	0.18	43.21	9.63	0.02	52.86	64.42	-11.56	QP
3	0.26	23.89	9.60	0.03	33.52	51.38	-17.86	Average
4	0.26	38.94	9.60	0.03	48.57	61.38	-12.81	QP
5	0.40	17.87	9.61	0.04	27.52	47.90	-20.38	Average
6	0.40	30.96	9.61	0.04	40.61	57.90	-17.29	QP
7	3.12	9.33	9.64	0.06	19.03	46.00	-26.97	Average
8	3.12	33.27	9.64	0.06	42.97	56.00	-13.03	QP
9	8.11	17.78	9.70	0.07	27.55	50.00	-22.45	Average
10	8.11	32.83	9.70	0.07	42.60	60.00	-17.40	QP
11	20.16	15.61	9.88	0.12	25.61	50.00	-24.39	Average
12	20.16	30.59	9.88	0.12	40.59	60.00	-19.41	QP

Remarks: 1. Measured = Reading + Lisn Factor +Cable Loss.
 2. The emission levels that are 20dB below the official limit are not reported.

***Note: Pre-scan all mode and recorded the worst case results in this report (802.11n HT20 (Low Channel, 2.4GHz Band)).

5.8. Antenna Requirements

5.8.1. Standard Applicable

According to § 15.203 & RSS-Gen, an intentional radiator shall be designed to ensure that no antenna other than that furnished by the responsible party shall be used with the device.

5.8.2. Antenna Connector Construction

The EUT used two standard SMA connectors which permanently attached on PCB. The antenna is permanently attached by special glue. Please see EUT photo for details.

5.8.3. Results: Compliance.

6. LIST OF MEASURING EQUIPMENTS

Instrument	Manufacturer	Model No.	Serial No.	Characteristics	Cal Date	Due Date
EMC Receiver	R&S	ESCS 30	100174	9kHz – 2.75GHz	June 18,2012	June 17,2013
Signal analyzer	Agilent	E4448A(External mixers to 40GHz)	US44300469	9kHz-40GHz	July 16,2012	July 15,2013
LISN	MESS Tec	NNB-2/16Z	99079	9KHz-30MHz	June 18,2012	June 17,2013
LISN (Support Unit)	EMCO	3819/2NM	9703-1839	9KHz-30MHz	June 18,2012	June 17,2013
RF Cable-CON	UTIFLEX	3102-26886-4	CB049	9KHz-30MHz	June 18,2012	June 17,2013
ISN	SCHAFFNER	ISN ST08	21653	9KHz-30MHz	June 18,2012	June 17,2013
3m Semi Anechoic Chamber	SIDT FRANKONIA	SAC-3M	03CH03-HY	30M-1GHz 3m	June 18,2012	June 17,2013
Amplifier	SCHAFFNER	COA9231A	18667	9kHz-2GHz	June 18,2012	June 17,2013
Amplifier	Agilent	8449B	3008A02120	1GHz-26.5GHz	July 16,2012	July 15,2013
Amplifier	MITEQ	AMF-6F-260400	9121372	26.5GHz-40GHz	July 16,2012	July 15,2013
Spectrum Analyzer	Agilent	E4407B	MY41440292	9k-26.5GHz	July 16,2012	July 15,2013
Loop Antenna	R&S	HFH2-Z2	860004/001	9k-30MHz	June 18,2012	June 17,2013
By-log Antenna	SCHAFFNER	CBL 6112D	22237	30MHz-1GHz	June 10,2012	June 09,2013
Horn Antenna	EMCO	3115	6741	1GHz-18GHz	June 10,2012	June 09,2013
Horn Antenna	SCHWARZBECK	BBHA9170	BBHA9170154	15GHz-40GHz	June 10,2012	June 09,2013
RF Cable-R03m	Jye Bao	RG142	CB021	30MHz-1GHz	June 18,2012	June 17,2013
RF Cable-HIGH	SUHNER	SUCOFLEX 106	03CH03-HY	1GHz-40GHz	June 18,2012	June 17,2013
Spectrum Meter	R&S	FSP 30	100023	9kHz-30GHz	July 16,2012	July 15,2013
Power Meter	R&S	NRVS	100444	DC-40GHz	June 18,2012	June 17,2013
Power Sensor	R&S	NRV-Z51	100458	DC-30GHz	June 18,2012	June 17,2013
Power Sensor	R&S	NRV-Z32	10057	30MHz-6GHz	June 18,2012	June 17,2013
AC Power Source	HPC	HPA-500E	HPA-9100024	AC 0~300V	June 18,2012	June 17,2013
DC power Source	GW	GPC-6030D	C671845	DC 1V-60V	June 18,2012	June 17,2013
Temp. and Humidigy	Giant Force	GTH-225-20-S	MAB0103-00	N/A	June 18,2012	June 17,2013
RF CABLE-1m	JYE Bao	RG142	CB034-1m	20MHz-7GHz	June 18,2012	June 17,2013
RF CABLE-2m	JYE Bao	RG142	CB)35-2m	20MHz-1GHz	June 18,2012	June 17,2013
Vector signal Generator	R&S	SMU200A	102098	100kHz~6GHz	June 18,2012	June 17,2013
Signal Generator	R&S	SMR40	10016	10MHz~40GHz	July 16,2012	July 15,2013
Oscilloscope	Tektonix	TDS380	B016197	400MHz/2GRS	July 16,2012	July 15,2013

7. MANUFACTURER/ APPROVAL HOLDER DECLARATION

The following series model(s):

--	--	--	--
----	----	----	----

Belong to the tested device:

Product description : 300Mbps 802.11n/a/b/g Wireless Dual Band
USB Adapter

Model name : RNX-N600UBE

Remark: No additional models were tested.

-----THE END OF REPORT-----