



FCC PART 15C TEST REPORT FOR CERTIFICATION
On Behalf of

Rosewill Inc.

AC750 Wireless Dual Band Gigabit Router

Model Number: RNX-AC750RT

FCC ID: W6RRNX-AC750RT

Prepared for : Rosewill Inc.
17708 Rowland Street, City of Industry, CA 91748, USA.

Prepared By : Audix Technology (Shenzhen) Co., Ltd.
No. 6, Ke Feng Rd., 52 Block,
Shenzhen Science & Industrial Park,
Nantou, Shenzhen, Guangdong, China

Tel: (0755) 26639496

Report Number : ACS-F14295
Date of Test : Apr.16 ~ Sep.26, 2014
Date of Report : Oct.11, 2014

TABLE OF CONTENTS

Description	Page
1. SUMMARY OF STANDARDS AND RESULTS	1-1
1.1. Description of Standards and Results	1-1
2. GENERAL INFORMATION	2-1
2.1. Description of Device (EUT)	2-1
2.2. Test Information	2-2
2.3. Tested Supporting System Details	2-2
2.4. Block Diagram of Test Setup	2-2
2.5. Test Facility	2-3
2.6. Measurement Uncertainty (95% confidence levels, k=2).....	2-3
3. POWER LINE CONDUCTED EMISSION TEST.....	3-1
3.1. Test Equipments	3-1
3.2. Block Diagram of Test Setup	3-1
3.3. Power Line Conducted Emission Test Limits	3-1
3.4. Configuration of EUT on Test.....	3-2
3.5. Operating Condition of EUT	3-2
3.6. Test Procedure	3-2
3.7. Power Line Conducted Emission Test Results	3-2
4. RADIATED EMISSION TEST	4-1
4.1. Test Equipment.....	4-1
4.2. Block Diagram of Test Setup	4-2
4.3. Radiated Emission Limit	4-3
4.4. EUT Configuration on Test	4-3
4.5. Operating Condition of EUT	4-3
4.6. Test Procedure	4-4
4.7. Radiated Emission Test Results	4-4
5. BAND EDGE COMPLIANCE TEST	5-1
5.1. Test Equipment.....	5-1
5.2. Limit	5-1
5.3. Test Produce	5-1
5.4. Test Results	5-1
6. 20dB & 26dB Bandwidth Test	6-1
6.1. Test Equipment.....	6-1
6.2. Limit	6-1
6.3. Test Procedure	6-1
6.4. Test Results	6-1
7. OUTPUT POWER TEST	7-1
7.1. Test Equipment.....	7-1
7.2. Limit	7-1
7.3. Test Procedure	7-1
7.4. Test Results	7-2
8. POWER SPECTRAL DENSITY TEST	8-1
8.1. Test Equipment.....	8-1
8.2. Limit	8-1
8.3. Test Procedure	8-1
8.4. Test Results	8-2
9. PEAK EXCURSION MEASUREMENT	9-1
9.1. Test Equipment.....	9-1

9.2.	Limit	9-1
9.3.	Test Procedure	9-1
9.4.	Test Results	9-2
10.	FREQUENCY STABILITY MEASUREMENT	10-1
10.1.	Test Equipment	10-1
10.2.	Limit	10-1
10.3.	Test Procedure	10-1
10.4.	Test Result	10-2
11.	MPE ESTIMATION	11-1
11.1.	Limit for General Population/ Uncontrolled Exposures	11-1
11.2.	Estimation Result	11-1
12.	NTENNA REQUIREMENT	12-1
12.1.	STANDARD APPLICABLE	12-1
12.2.	ANTENNA CONNECTED CONSTRUCTION	12-1
13.	DEVIATION TO TEST SPECIFICATIONS	13-1
14.	PHOTOGRAPH OF TEST	14-1
14.1.	Photos of Power Line Conducted Emission Test	14-1
14.2.	Photos of Radiated Emission Test	14-2

TEST REPORT CERTIFICATION

Applicant : Rosewill Inc.
Manufacturer : Rosewill Inc.
EUT Description : AC750 Wireless Dual Band Gigabit Router
FCC ID : W6RRNX-AC750RT
(A) MODEL NO. : RNX-AC750RT
(B) SERIAL NO. : N/A
(C) POWER SUPPLY : Input: 100~240V~, 50/60Hz, 0.3A
Output: 12V---1.5A
(D) TEST VOLTAGE : DC 12V From Adapter input AC 120V/60Hz

Tested for comply with:
FCC Rules and Regulations Part 15 Subpart E: 2013

Test procedure used:
ANSI C63.10:2009
KDB789033D01: KDB644545D01

The device described above is tested by AUDIX TECHNOLOGY (SHENZHEN) CO., LTD. to confirm comply with all the FCC Part 15 Subpart C requirements. The test results are contained in this test report and AUDIX TECHNOLOGY (SHENZHEN) CO., LTD. is assumed full responsibility for the accuracy and completeness of these tests. Also, this report shows that the Equipment Under Test (EUT) is to be technically compliant with the FCC and IC requirements. This report contains data that are not covered by the NVLAP accreditation.

This Report is made under FCC Part 2.1075. No modifications were required during testing to bring this product into compliance.

This report applies to above tested sample only. This report shall not be reproduced in part without written approval of AUDIX TECHNOLOGY (SHENZHEN) CO., LTD.

The report must not be used by the client to claim product certification, approval, or endorsement by NVLAP, NIST, or any agency of the federal government.

Date of Test : Apr.16 ~ Sep.16, 2014 Report of date: Oct.11, 2014

Prepared by : April Tseng / Assistant Reviewed by : Sunny Lu / Assistant Manager

信華科技(深圳)有限公司
Audix Technology (Shenzhen) Co., Ltd.
EMC 部門報告專用章

Stamp only for EMC Dept. Report

Signature: David Jin

Approved & Authorized Signer : David Jin / Manager

1. SUMMARY OF STANDARDS AND RESULTS

1.1. Description of Standards and Results

The EUT have been tested according to the applicable standards as referenced below.

EMISSION		
Description of Test Item	Standard	Results
Power Line Conducted Emission	FCC Part 15: 15.207 ANSI C63.10: 2009	PASS
Radiated Emission	FCC Part 15: 15.209 ANSI C63.10: 2009	PASS
Band Edge Compliance	FCC Part 15: 15.247 ANSI C63.10: 2009	PASS
26dB Bandwidth Test	FCC Part 15: 15.407(a)	PASS
Output Power Test	FCC Part 15: 15.407(a)	PASS
Power Spectral Density Test	FCC Part 15: 15.407(a)	PASS
Peak Excursion	FCC Part 15: 15.407(a)	PASS
Frequency Stability	FCC Part 15: 15.407(g) ANSI C63.10: 2009	PASS
Antenna requirement	FCC Part 15: 15.203	PASS

2. GENERAL INFORMATION

2.1. Description of Device (EUT)

Product Name : AC750 Wireless Dual Band Gigabit Router

Model No. : RNX-AC750RT

FCC ID : W6RRNX-AC750RT

Radio : IEEE802.11 a/b/g/n/ac

Operation Frequency : IEEE 802.11a: 5180MHz—5240MHz
5745MHz—5825MHz

IEEE 802.11ac VHT20: 5180MHz—5240MHz,
5745MHz—5825MHz

IEEE 802.11ac VHT40: 5190MHz—5230MHz,
5755MHz—5795MHz

IEEE 802.11ac VHT80: 5210MHz, 5775MHz

IEEE 802.11b: 2412MHz—2462MHz

IEEE 802.11g: 2412MHz—2462MHz

IEEE802.11nHT20: 2412MHz—2462MHz;5180MHz—5240MHz,
5745MHz—5825MHz

IEEE802.11nHT40: 2422MHz—2452MHz5190MHz—5230MHz,
5755MHz—5795MHz

Modulation Technology : IEEE 802.11b: DSSS(CCK,DQPSK,DBPSK)

IEEE 802.11a/g: OFDM(64QAM, 16QAM, QPSK, BPSK)

IEEE 802.11ac VHT20, VHT40, VHT80: OFDM (16QAM, 64QAM,
256QAM, QPSK, BPSK)

IEEE 802.11n HT20, HT40: OFDM (64QAM, 16QAM,QPSK,BPSK)

Antenna : Antenna 0:

Assembly Gain Dipole antenna,
2.4GHz: 2dBi(max)
5GHz: 3dBi(max)

Antenna 1:

Dipole antenna,
2.4GHz: 2dBi(max)

Applicant : Rosewill Inc.
17708 Rowland Street, City of Industry, CA 91748, USA.

Manufacturer : Rosewill Inc.
17708 Rowland Street, City of Industry, CA 91748, USA.

Power Adaptor : Manufacture :HuntKey, M/N: HKA01812015-2K
 Power Cable: Unshielded, Detachable, 1.5m

Date of Test : Apr.16 ~ Sep.26, 2014

Date of Receipt : Apr.14, 2014

Sample Type : Prototype production

2.2. Test Information

A special test software was used to control EUT work in Continuous TX mode(100% duty cycle), and select test channel, wireless mode and data rate.

This device have two antennas , only antenna 0 use 5GHz band.

2.3. Tested Supporting System Details

No.	Description	ACS No.	Manufacturer	Model	Serial Number	Approved type
1.	Personal Computer	Test PC M	DELL	Studio 540	224XK2X	<input checked="" type="checkbox"/> FCC DoC <input checked="" type="checkbox"/> BSMI ID:R33002
		Power Cord: Unshielded, Detachable, 1.8m Display Card: HD3450 (DVI+VGA+HDMI)				
2.	USB Mouse	ACS-EMC-M04R	DELL	M0C5UO	512024282	<input checked="" type="checkbox"/> FCC DoC <input checked="" type="checkbox"/> BSMI ID: R41108
		Power Cord: shielded, Undetachable, 1.8m				
3.	USB Keyboard	ACS-EMC- K03R	DELL	SK-8115	CN-ODJ313-71 616-711-04WJ	<input checked="" type="checkbox"/> FCC DoC <input checked="" type="checkbox"/> BSMI ID: T3A002
		Power Cord: shielded, Undetachable, 2.0m				
4.	USB Disk	N/A	Kingston	N/A	N/A	4GB mini memory

2.4. Block Diagram of Test Setup

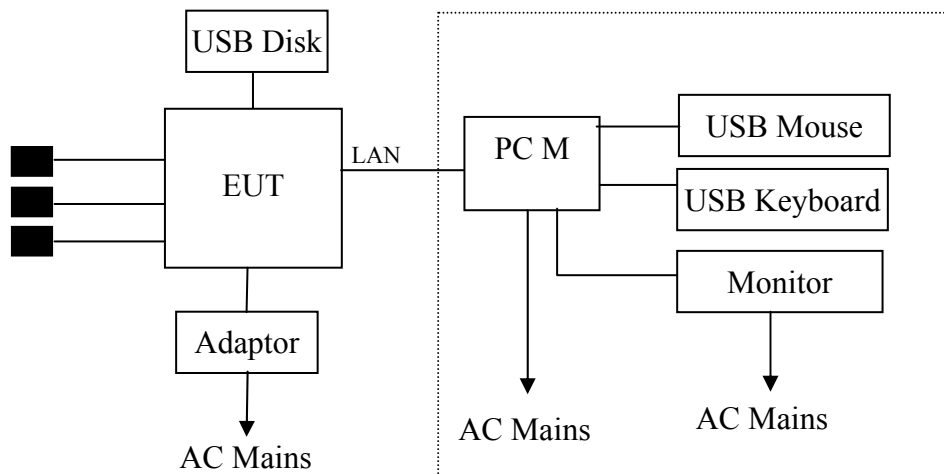

■ :100Ω

(EUT: AC750 Wireless Dual Band Gigabit Router)

2.5. Test Facility

Site Description

Name of Firm : Audix Technology (Shenzhen) Co., Ltd.
No. 6, Ke Feng Rd., 52 Block, Shenzhen
Science & Industrial Park, Nantou,
Shenzhen, Guangdong, China

3m Anechoic Chamber : Certificated by FCC, USA
Registration Number: 90454
Valid Date: Feb.22, 2015

3m & 10m Anechoic Chamber : Certificated by FCC, USA
Registration Number: 794232
Valid Date: Oct.31, 2015

EMC Lab. : Certificated by Industry Canada
Registration Number: IC 5183A-1
Valid Date: Jun.13, 2014

: Certificated by DAkkS, Germany
Registration No: D-PL-12151-01-00
Valid Date: Dec.15, 2016

Accredited by NVLAP, USA
NVLAP Code: 200372-0
Valid Date: Mar.31, 2015

2.6. Measurement Uncertainty (95% confidence levels, k=2)

Test Item	Uncertainty
Uncertainty for Conduction emission test in No. 1 Conduction	3.10 dB(150kHz to 30MHz)
Uncertainty for Radiation Emission test in 3m chamber	3.22 dB(30~200MHz, Polarize: H)
	3.23 dB(30~200MHz, Polarize: V)
	3.49 dB(200M~1GHz, Polarize: H)
	3.39 dB(200M~1GHz, Polarize: V)
Uncertainty for Radiation Emission test in 3m chamber (1GHz-18GHz)	4.97 dB(1~6GHz, Distance: 3m)
	4.99 dB(6~18GHz, Distance: 3m)
Uncertainty for Radiated Spurious Emission test in RF chamber	3.57 dB
Uncertainty for Conduction Spurious emission test	2.00 dB
Uncertainty for Output power test	0.73 dB
Uncertainty for Power density test	2.00 dB
Uncertainty for Frequency range test	7×10^{-8}
Uncertainty for Bandwidth test	83 kHz
Uncertainty for DC power test	0.038 %
Uncertainty for test site temperature and humidity	0.6°C
	3%

3. POWER LINE CONDUCTED EMISSION TEST

3.1. Test Equipments

Item	Equipment	Manufacturer	Model No.	Serial No.	Last Cal.	Cal. Interval
1.	1# Shielding Room	AUDIX	N/A	N/A	Apr.17,14	1 Year
2.	Test Receiver	Rohde & Schwarz	ESHS10	838693/001	Oct.31, 13	1 Year
3.	L.I.S.N.#1	Rohde & Schwarz	ESH2-Z5	100429	Jan.22, 14	1 Year
4.	L.I.S.N.#3	Kyoritsu	KNW-242C	8-1920-1	Apr. 28,14	1 Year
5.	Terminator	Hubersuhner	50Ω	No. 1	Apr. 28,14	1 Year
6.	Terminator	Hubersuhner	50Ω	No. 2	Apr. 28,14	1 Year
7.	RF Cable	Hubersuhner	RG58	0100.6954.20#	Jan.22, 14	1 Year
8.	Coaxial Switch	Anritsu	MP59B	6200298346	Apr. 28,14	1 Year
9.	Pulse Limiter	Rohde & Schwarz	ESH3-Z2	101838	Jan.22, 14	1 Year

3.2. Block Diagram of Test Setup

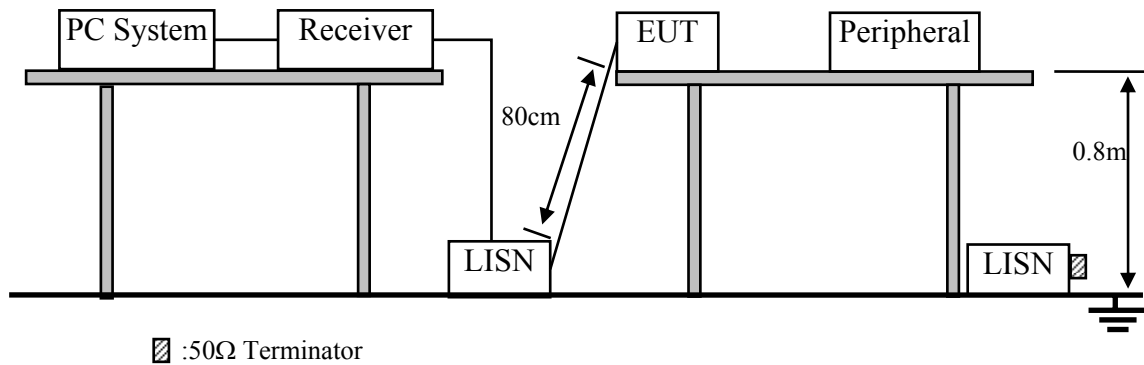

3.3. Power Line Conducted Emission Test Limits

Frequency	Maximum RF Line Voltage	
	Quasi-Peak Level dB(μV)	Average Level dB(μV)
150kHz ~ 500kHz	66 ~ 56*	56 ~ 46*
500kHz ~ 5MHz	56	46
5MHz ~ 30MHz	60	50

Notes: 1. * Decreasing linearly with logarithm of frequency.

2. The lower limit shall apply at the transition frequencies.

3.4. Configuration of EUT on Test

The following equipment are installed on Power Line Conducted Emission Test to meet the commission requirement and operating regulations in a manner which tends to maximize its emission characteristics in a normal application.

3.4.1. AC750 Wireless Dual Band Gigabit Router (EUT)

Model Number : RNX-AC750RT

Serial Number : N/A

3.4.2. Support Equipment: As Tested Supporting System Details, in Section 2.2.

3.5. Operating Condition of EUT

3.5.1. Setup the EUT and simulator as shown as Section 3.2.

3.5.2. Turned on the power of all equipment.

3.5.3. PC run test software to control EUT work in Tx mode.

3.6. Test Procedure

The EUT was placed on a non-metallic table, 80cm above the ground plane. The EUT Power connected to the power mains through a line impedance stabilization network (L.I.S.N. 1#). This provides a 50 ohm coupling impedance for the EUT (Please refer the block diagram of the test setup and photographs). The AC line are checked to find out the maximum conducted emission. In order to find the maximum emission levels, the relative positions of equipment and all of the interface cables shall be changed according to ANSI C63.10: 2009 on Conducted Emission Test.

The bandwidth of test receiver (R & S ESHS10) is set at 9kHz.

The frequency range from 150kHz to 30MHz is checked.

3.7. Power Line Conducted Emission Test Results

PASS. (All emissions not reported below are too low against the prescribed limits.)

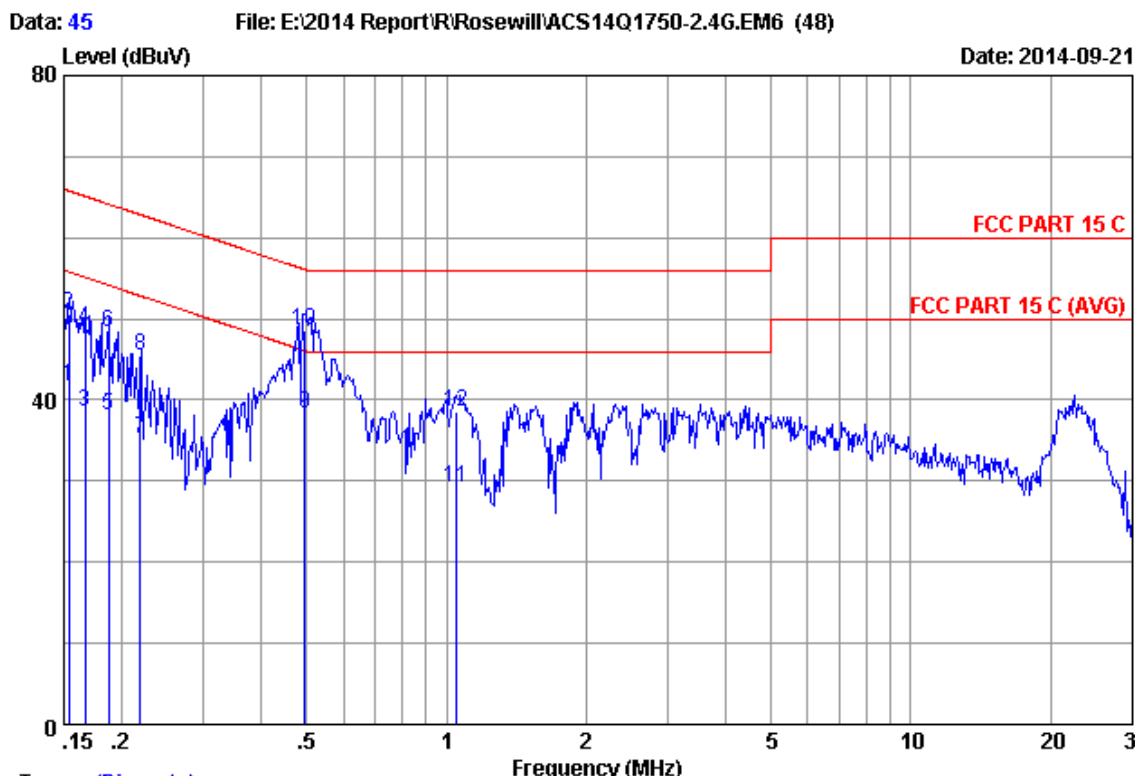

Trace: (Discrete)

Site no :1# Conduction Data No :45
 Dis./Ant. :2014 ESH2-Z5 LINE
 Limit :FCC PART 15 C
 Env./Ins. :26.1*C/56% Engineer :Nick_Huang
 EUT :AC750 Wireless Dual Band
 Power Rating :DC 12V Adapter Input AC 230V/50Hz
 Test Mode :TX Mode(5G)
 M/N:PW-AC4573R

No	Freq (MHz)	LISN Factor (dB)	Cable Loss (dB)	Reading (dBuV)	Emission Level (dBuV)	Limits (dBuV)	Margin (dB)	Remark
1	0.15400	0.12	9.87	31.60	41.59	55.78	14.19	Average
2	0.15400	0.12	9.87	40.65	50.64	65.78	15.14	QP
3	0.16700	0.12	9.87	28.51	38.50	55.11	16.61	Average
4	0.16700	0.12	9.87	38.84	48.83	65.11	16.28	QP
5	0.18700	0.13	9.88	28.09	38.10	54.17	16.07	Average
6	0.18700	0.13	9.88	38.30	48.31	64.17	15.86	QP
7	0.21900	0.13	9.88	25.30	35.31	52.86	17.55	Average
8	0.21900	0.13	9.88	35.35	45.36	62.86	17.50	QP
9	0.49500	0.15	9.88	28.40	38.43	46.08	7.65	Average
10	0.49500	0.15	9.88	38.49	48.52	56.08	7.56	QP
11	1.048	0.17	9.89	19.20	29.26	46.00	16.74	Average
12	1.048	0.17	9.89	28.51	38.57	56.00	17.43	QP

Remarks: 1.Emission Level=LISN Factor+Cable Loss(Include 10dB pulse limit)+Reading.
 2.If the average limit is met when using a quasi-peak detector, the EUT shall be deemed to meet both limits and measurement with average detector is unnecessary.

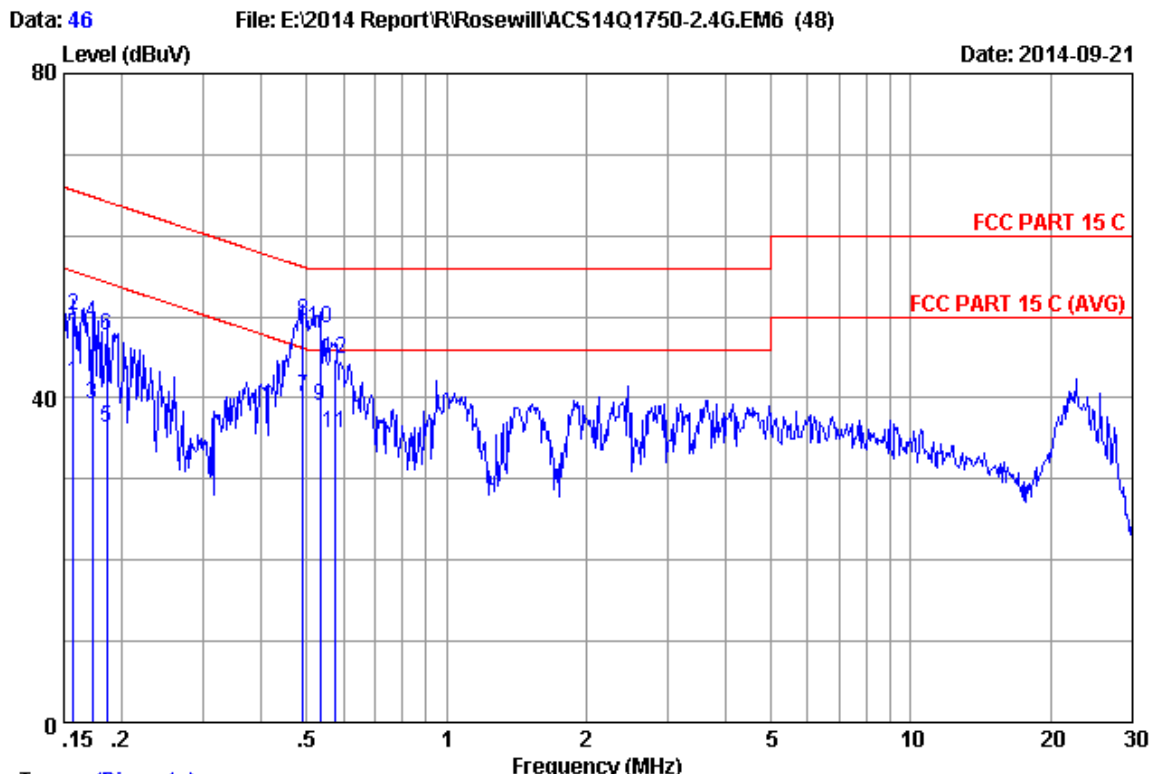

Trace: (Discrete)

Site no :1# Conduction Data No :46
 Dis./Ant. :2014 ESH2-25 NEUTRAL
 Limit :FCC PART 15 C
 Env./Ins. :26.1*C/56% Engineer :Nick_Huang
 EUT :AC750 Wireless Dual Band
 Power Rating :DC 12V Adapter Input AC 230V/50Hz
 Test Mode :TX Mode(5G)
 M/N:PW-AC4573R

No	Freq (MHz)	LISN Factor (dB)	Cable Loss (dB)	Reading (dBuV)	Emission Level (dBuV)	Limits (dBuV)	Margin (dB)	Remark
1	0.15700	0.13	9.87	31.90	41.90	55.62	13.72	Average
2	0.15700	0.13	9.87	40.13	50.13	65.62	15.49	QP
3	0.17300	0.13	9.87	29.30	39.30	54.82	15.52	Average
4	0.17300	0.13	9.87	39.31	49.31	64.82	15.51	QP
5	0.18600	0.13	9.88	26.40	36.41	54.21	17.80	Average
6	0.18600	0.13	9.88	37.64	47.65	64.21	16.56	QP
7	0.49100	0.15	9.88	30.10	40.13	46.15	6.02	Average
8	0.49100	0.15	9.88	39.37	49.40	56.15	6.75	QP
9	0.53400	0.15	9.88	28.90	38.93	46.00	7.07	Average
10	0.53400	0.15	9.88	38.45	48.48	56.00	7.52	QP
11	0.57600	0.15	9.88	25.60	35.63	46.00	10.37	Average
12	0.57600	0.15	9.88	34.76	44.79	56.00	11.21	QP

Remarks: 1.Emission Level=LISN Factor+Cable Loss(Include 10dB pulse limit)+Reading.

2.If the average limit is met when using a quasi-peak detector, the EUT shall be deemed to meet both limits and measurement with average detector is unnecessary.

4. RADIATED EMISSION TEST

4.1. Test Equipment

4.1.1. For frequency range 30MHz~1000MHz (In 3m Anechoic Chamber)

Item	Equipment	Manufacturer	Model No.	Serial No.	Last Cal.	Cal. Interval
1.	3#Chamber	AUDIX	N/A	N/A	Nov.24, 13	1 Year
2.	EMI Spectrum	Agilent	E4407B	MY41440292	Apr. 28,14	1 Year
3.	Test Receiver	Rohde & Schwarz	ESVS10	834468/011	Apr. 28,14	1 Year
4.	Amplifier	HP	8447D	2648A04738	Apr. 28,14	1 Year
5.	Bilog Antenna	TESEQ	CBL6112D	35375	Jun. 18, 14	1 Year
6.	RF Cable	MIYAZAKI	CFD400-NL	3# Chamber No.1	Apr. 28,14	1 Year
7.	Coaxial Switch	Anritsu	MP59B	6200313662	Apr. 28,14	1 Year

4.1.2. For frequency range 1GHz~40GHz (In 3m Anechoic Chamber)

Item	Equipment	Manufacturer	Model No.	Serial No.	Last Cal.	Cal. Interval
1.	3#Chamber	AUDIX	N/A	N/A	Nov.03, 13	1 Year
2.	Spectrum Analyzer	Agilent	E4407B	MY41440292	Apr. 28,14	1 Year
3.	Horn Antenna	ETS	3115	9607-4877	Aug.27, 13	1 Year
4.	Horn Antenna	ETS	3116	00060089	Aug.27, 14	1 Year
5.	Amplifier	Agilent	8449B	3008A00863	Apr. 28,14	1 Year
6.	RF Cable	Hubersuhner	SUCOFLEX106	77977/6	Apr. 28,14	1 Year
7.	RF Cable	Hubersuhner	SUCOFLEX106	28616/2	Apr. 28,14	1 Year
8.	MPEG2 Measurement Generator	ROHDE&SC HWARZ	DVG	100319	Dec.11, 13	1 Year
9.	TV Transmitter	ROHDE&SC HWARZ	SFQ	100521	Apr. 28,14	1 Year
10.	Pattern Generator	Philips	PM5418	LO625020	Apr. 28,14	1 Year

4.2. Block Diagram of Test Setup

4.2.1. For frequency range 30MHz-1000MHz

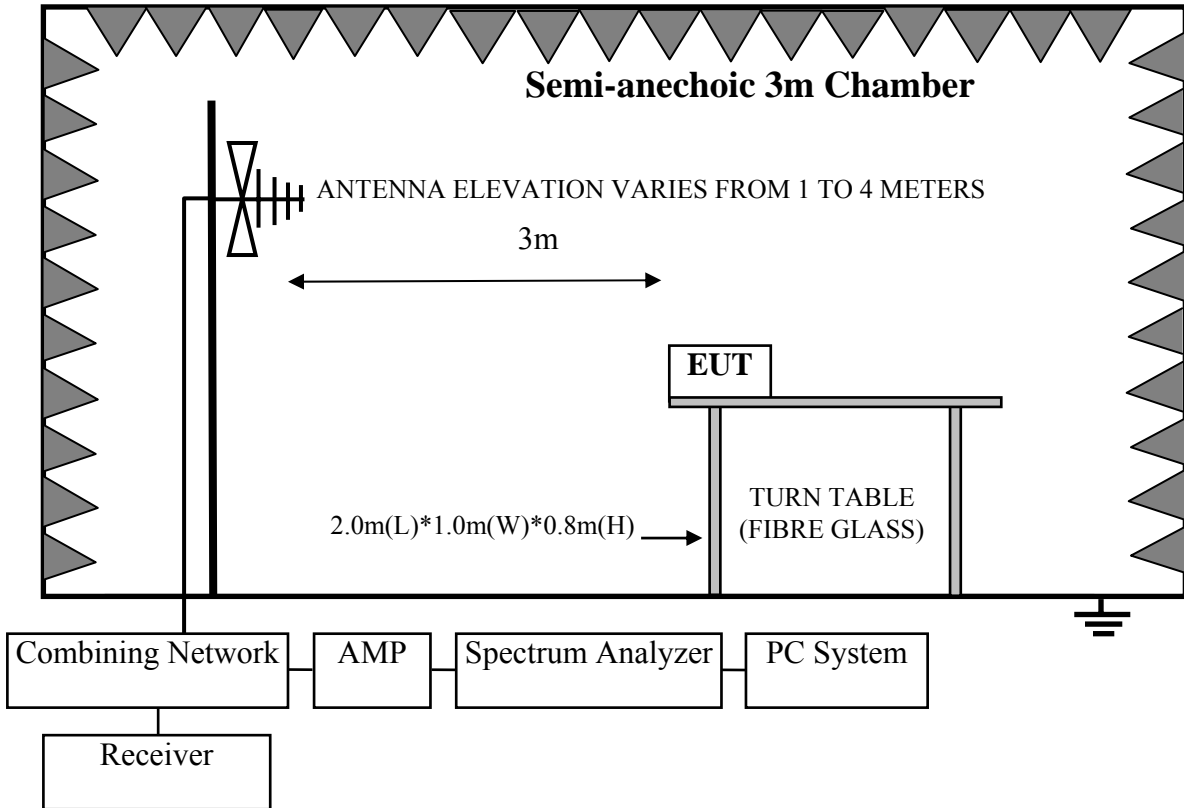

4.2.2. For frequency range 1GHz-40GHz

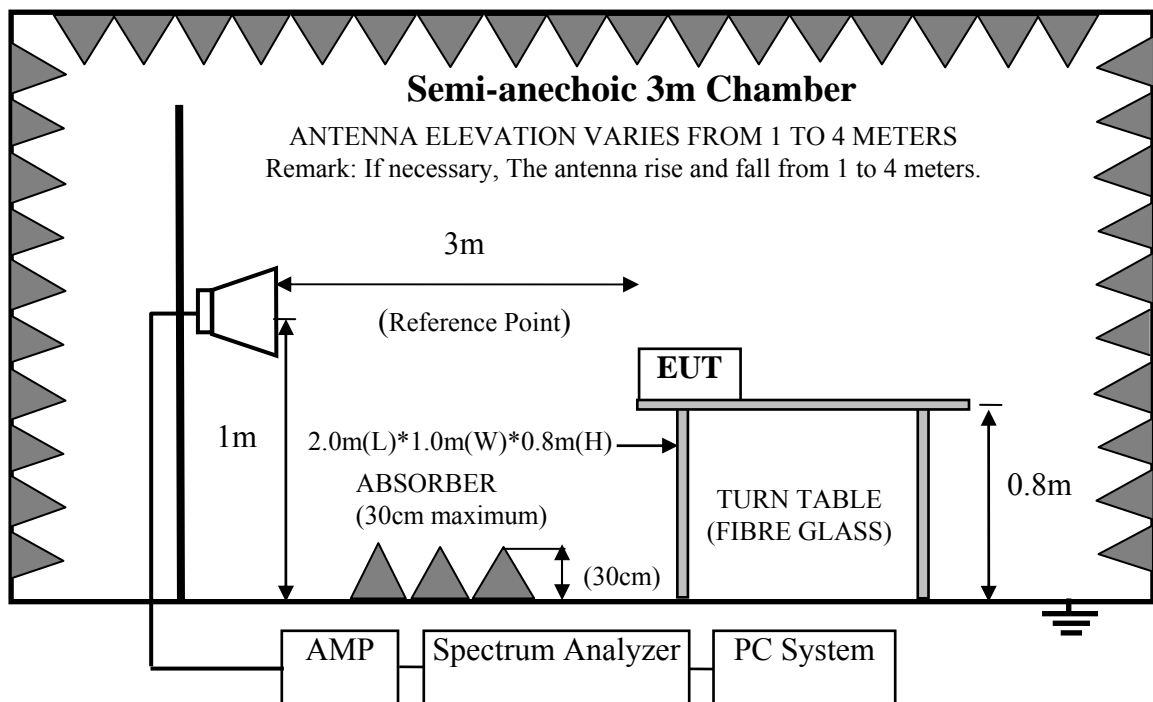

4.3.Radiated Emission Limit

For transmitters operating in the 5.15-5.25 GHz; 5.25-5.35GHz; 5.47-5.725GHz band: all emissions outside of those band shall not exceed an EIRP of -27 dBm/MHz.

Unwanted emissions below 1 GHz and those emissions appearing within 15.205 restricted frequency bands must comply with the general field strength limits set forth in Section 15.209

4.3.1.15.209 limits

FREQUENCY MHz	DISTANCE Meters	FIELD STRENGTHS LIMIT	
		μV/m	dB(μV)/m
30 ~ 88	3	100	40.0
88 ~ 216	3	150	43.5
216 ~ 960	3	200	46.0
960 ~ 1000	3	500	54.0
Above 1000	3	74.0 dB(μV)/m (Peak) 54.0 dB(μV)/m (Average)	

Remark : (1) Emission level dBμV = 20 log Emission level μV/m

(2) The smaller limit shall apply at the cross point between two frequency bands.

(3) Distance is the distance in meters between the measuring instrument, antenna and the closest point of any part of the device or system.

4.3.2.15.205 Restricted bands of operation

MHz	MHz	MHz	GHz
0.090 - 0.110	16.42 - 16.423	399.9 - 410	4.5 - 5.15
¹ 0.495 - 0.505	16.69475 - 16.69525	608 - 614	5.35 - 5.46
2.1735 - 2.1905	16.80425 - 16.80475	960 - 1240	7.25 - 7.75
4.125 - 4.128	25.5 - 25.67	1300 - 1427	8.025 - 8.5
4.17725 - 4.17775	37.5 - 38.25	1435 - 1626.5	9.0 - 9.2
4.20725 - 4.20775	73 - 74.6	1645.5 - 1646.5	9.3 - 9.5
6.215 - 6.218	74.8 - 75.2	1660 - 1710	10.6 - 12.7
6.26775 - 6.26825	108 - 121.94	1718.8 - 1722.2	13.25 - 13.4
6.31175 - 6.31225	123 - 138	2200 - 2300	14.47 - 14.5
8.291 - 8.294	149.9 - 150.05	2310 - 2390	15.35 - 16.2
8.362 - 8.366	156.52475 - 156.52525	2483.5 - 2500	17.7 - 21.4
8.37625 - 8.38675	156.7 - 156.9	2690 - 2900	22.01 - 23.12
8.41425 - 8.41475	162.0125 - 167.17	3260 - 3267	23.6 - 24.0
12.29 - 12.293	167.72 - 173.2	3332 - 3339	31.2 - 31.8
12.51975 - 12.52025	240 - 285	3345.8 - 3358	36.43 - 36.5
12.57675 - 12.57725	322 - 335.4	3600 - 4400	(²)

4.4.EUT Configuration on Test

The configurations of EUT are listed in Section 3.4.

4.5.Operating Condition of EUT

Same as Conducted Emission test that is listed in Section 3.5. except the test set up replaced by Section 4.2.

4.6. Test Procedure

EUT and its simulators are placed on a turn table, which is 0.8 meter high above ground. The turn table can rotate 360 degrees to determine the position of the maximum emission level. Power on the EUT and let it working in test mode, then test it. EUT is set 3 meters away from the receiving antenna, which is mounted on a antenna tower. The antenna can be moved up and down between 1 meter and 4 meters to find out the maximum emission level. Broadband antenna (calibrated bilog antenna) is used as receiving antenna. Both horizontal and vertical polarization of the antenna are set on test.

For emissions below 1GHz and those emissions appearing within 15.205 restricted frequency bands use below procedure:

The bandwidth of the EMI test receiver (R&S ESVS10) is set at 120kHz for frequency range from 30MHz to 1000 MHz.

The bandwidth of the Spectrum's VBW is set at 1MHz and RBW is set at 1MHz for peak emissions measurement above 1GHz and 1MHz RBW, 10Hz VBW for average emissions measure above 1GHz

For the emissions above 1GHz and not appearing within 15.205 restricted frequency bands use below procedure:

- (1).The maximum emission at 3m distance was measured and recorded with receive antenna in both vertical and horizontal by rotating the turntable and by lowering the receive antenna.
- (2).The EUT was then removed and replaced with a substitution antenna in the same position and the substitution antenna must have the same polarization with the receive antenna.
- (3). A signal which have the same frequency obtained in step 2 was fed to the substitution, the receive antenna was raised and lowered to obtain a maximum reading at the test receiver, the level of the signal generator was adjusted until the measured field strength level in step 2 was obtained, recorded the level of the signal generator.
- (4).Repeated step 4 with both antenna polarizations
- (5).The spurious emissions is equal to the power supplied by the signal generator and corrections due to the gain of the substitution antenna and the cable loss between the signal generator and the substitution antenna.
- (6).Per KDB789033 clause H 2)d).if the test distance is 3m,the EIRP(dBm)=E(dBuv/m)-95.2
Get the result of all unwanted emission outside the restricted band is less than the -27dBm/MHz.

We had checked frequency range that is 30MHz to 10th harmonic (40GHz) and no any emissions were found from 18GHz to 40GHz, so the radiated emission from 18GHz to 40GHz were not record.

4.7. Radiated Emission Test Results

PASS.

All the emissions from 30MHz to 1 GHz were comply with 15.209 limits.

No any emissions were found from 18GHz to 40GHz, So the Radiated emissions from 18GHz to 40GHz were not record.

All other emission comply with 15.407 (b)(1) requirements.

Duty cycle

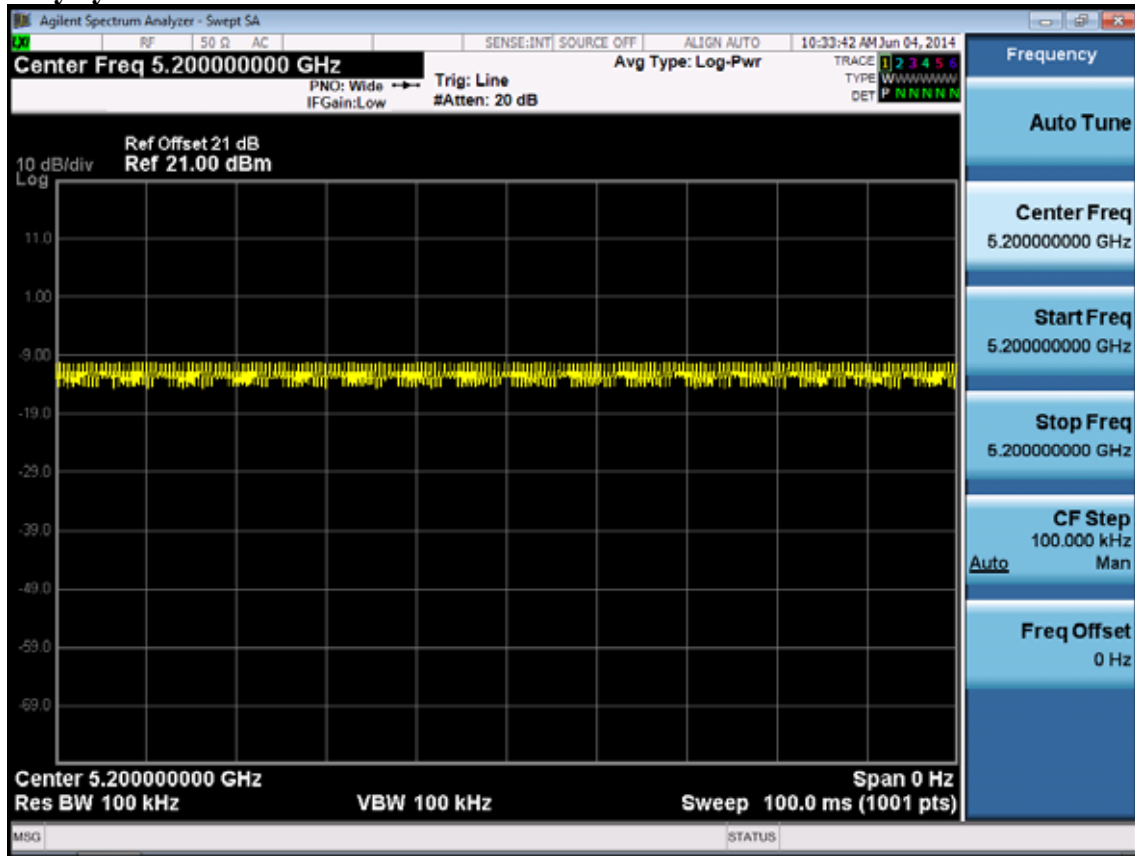

Note: The Duty Cycle is close to 100%.

Frequency: 30MHz~1GHz

Postcode:518057

Data: 9

File: E:\2014 Report\Rosewill\ACS14Q1750-2.4G.EM6 (12)

Date: 2014-09-21

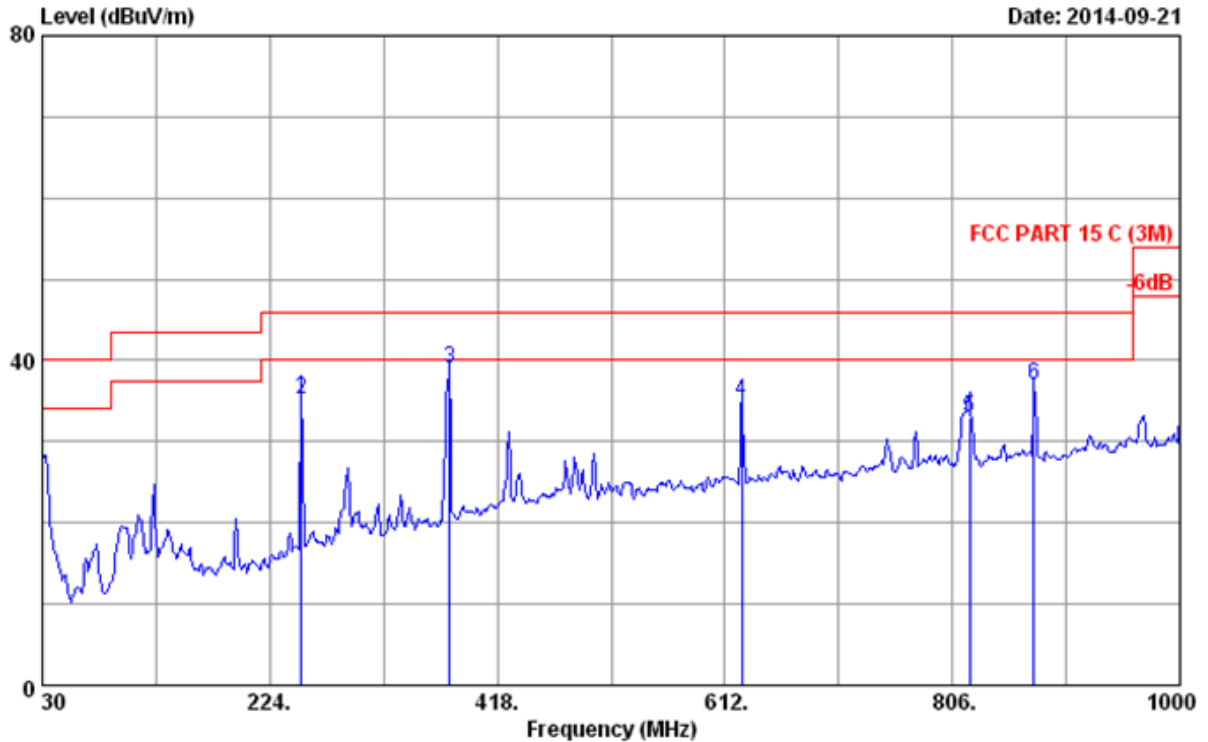

Site no. : 3m Chamber Data no. : 9
 Dis. / Ant. : 3m 2014 CBL6112D 35375 Ant. pol. : HORIZONTAL
 Limit : FCC PART 15 C (3M)
 Env. / Ins. : 24*C/56% Engineer : Leo_Li
 EUT : AC750 Wireless Dual Band Gigabit Router
 Power rating : DC 12V From Adapter Input AC 120V/60Hz
 Test Mode : TX Mode(5G)
 M/N:PW-AC4573R

No.	Freq. (MHz)	Ant. Factor (dB/m)	Cable Loss (dB)	Reading (dBuV)	Emission Level (dBuV/m)	Limits (dBuV/m)	Margin (dB)	Remark
1	30.000	19.60	0.60	5.29	25.49	40.00	14.51	QP
2	251.160	13.06	2.08	19.96	35.10	46.00	10.90	QP
3	377.260	15.85	2.70	20.50	39.05	46.00	6.95	QP
4	626.550	19.73	3.82	11.33	34.88	46.00	11.12	QP
5	820.550	21.10	4.56	7.36	33.02	46.00	12.98	QP
6	875.840	21.78	4.78	10.36	36.92	46.00	9.08	QP

Remarks: 1. Emission Level= Antenna Factor + Cable Loss + Reading.
 2. The emission levels that are 20dB below the official limit are not reported.

Data: 10 File: E:\2014 Report\R\Rosewill\ACS14Q1750-2.4G.EM6 (12)

Date: 2014-09-21

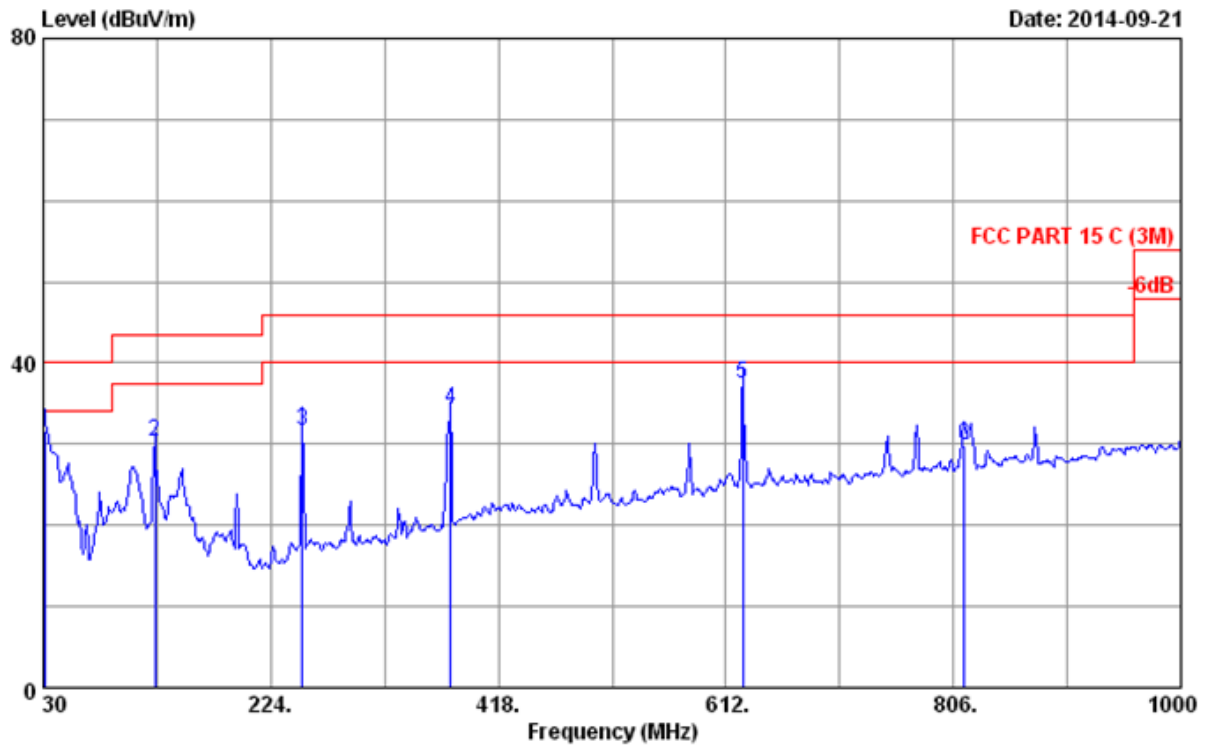

Site no. : 3m Chamber Data no. : 10
 Dis. / Ant. : 3m 2014 CBL6112D 35375 Ant. pol. : VERTICAL
 Limit : FCC PART 15 C (3M)
 Env. / Ins. : 24°C/56% Engineer : Leo_Li
 EUT : AC750 Wireless Dual Band Gigabit Router
 Power rating : DC 12V From Adapter Input AC 120V/60Hz
 Test Mode : TX Mode (5G)
 M/N:PW-AC4573R

No.	Freq. (MHz)	Ant. Factor (dB/m)	Cable Loss (dB)	Reading (dBuV)	Emission Level (dBuV/m)	Limits (dBuV/m)	Margin (dB)	Remark
1	31.940	18.82	0.62	12.29	31.73	40.00	8.27	QP
2	125.060	12.85	1.35	16.19	30.39	43.50	13.11	QP
3	251.160	13.06	2.08	16.40	31.54	46.00	14.46	QP
4	377.260	15.85	2.70	15.76	34.31	46.00	11.69	QP
5	626.550	19.73	3.82	13.88	37.43	46.00	8.57	QP
6	815.700	21.01	4.54	4.25	29.80	46.00	16.20	QP

Remarks: 1. Emission Level= Antenna Factor + Cable Loss + Reading.
 2. The emission levels that are 20dB below the official limit are not reported.

Frequency: 1GHz~18GHz

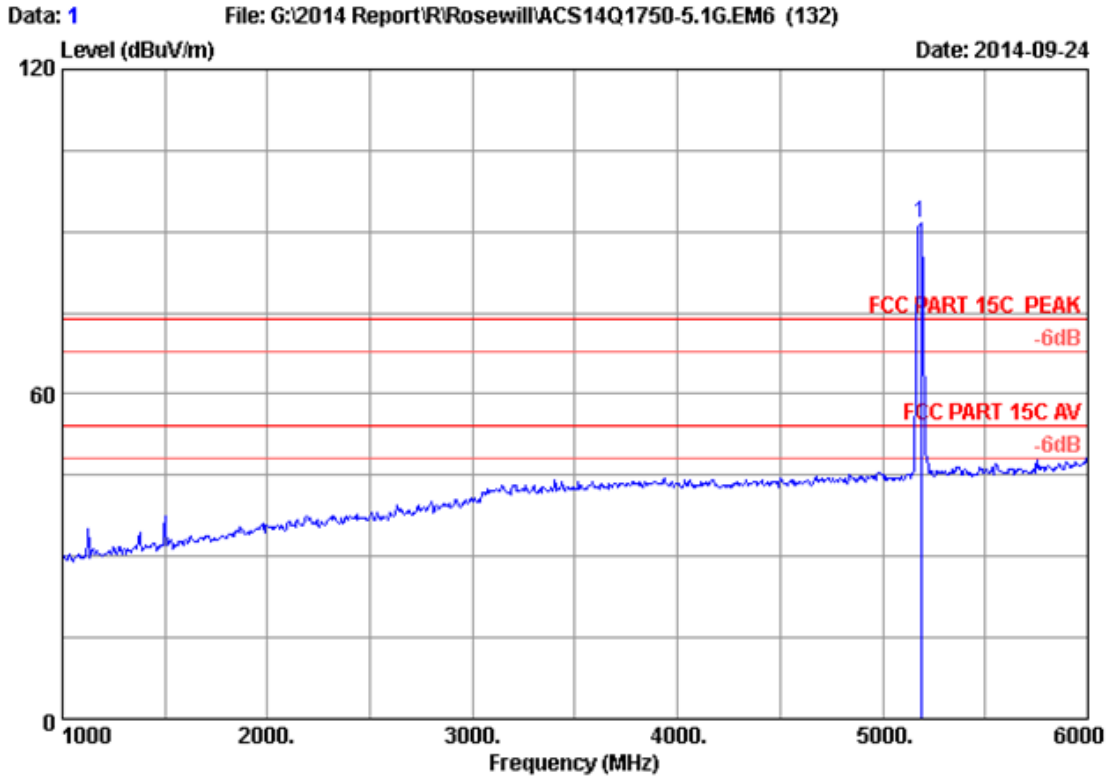

Site no. : 3m Chamber Data no. : 1
 Dis. / Ant. : 3m 2014 3115 (4580) Ant. pol. : HORIZONTAL
 Limit : FCC PART 15C PEAK
 Env. / Ins. : 24°C/56% Engineer : Leo-Li
 EUT : AC750 Wireless Dual Band Gigabit Router
 Power Rating : DC 12V From Adapter Input AC 120V/60Hz
 Test Mode : IEEE802.11a 5180MHz Tx
 M/N : RNX-AC750RT

No.	Freq. (MHz)	Ant. Factor (dB/m)	Cable Loss (dB)	AMP factor (dB)	Reading (dBuV)	Emission Level (dBuV/m)	Limits (dBuV/m)	Margin (dB)	Remark
1	5185.000	33.50	8.96	35.70	84.87	91.63	74.00	-17.63	Peak

Remarks: 1. Emission Level= Antenna Factor + Cable Loss + Reading - Amp Factor
 2. The emission levels that are 20dB below the official limit are not reported.

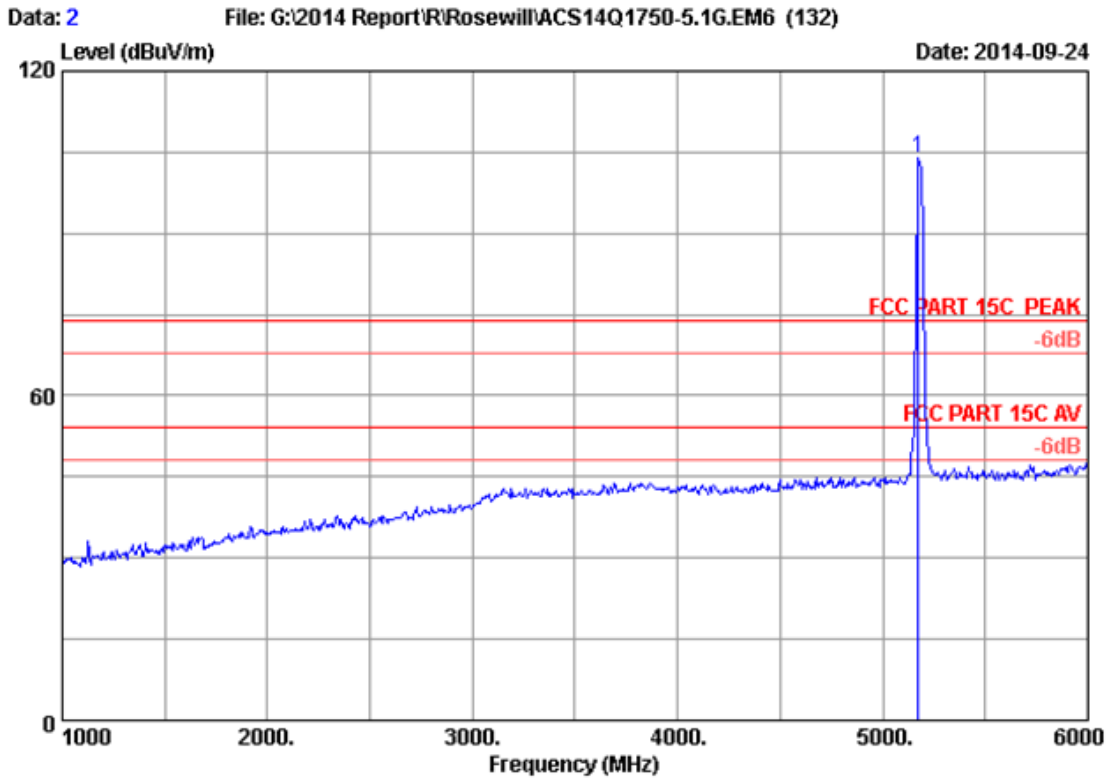

Site no. : 3m Chamber Data no. : 2
 Dis. / Ant. : 3m 2014 3115 (4580) Ant. pol. : VERTICAL
 Limit : FCC PART 15C PEAK
 Env. / Ins. : 24°C/56% Engineer : Leo-Li
 EUT : AC750 Wireless Dual Band Gigabit Router
 Power Rating : DC 12V From Adapter Input AC 120V/60Hz
 Test Mode : IEEE802.11a 5180MHz Tx
 M/N : RNX-AC750RT

No.	Freq. (MHz)	Ant. Factor (dB/m)	Cable Loss (dB)	AMP factor (dB)	Reading (dBuV)	Emission Level (dBuV/m)	Limits (dBuV/m)	Margin (dB)	Remark
1	5175.000	33.48	8.95	35.70	97.30	104.03	74.00	-30.03	Peak

Remarks: 1. Emission Level= Antenna Factor + Cable Loss + Reading - Amp Factor
 2. The emission levels that are 20dB below the official limit are not reported.

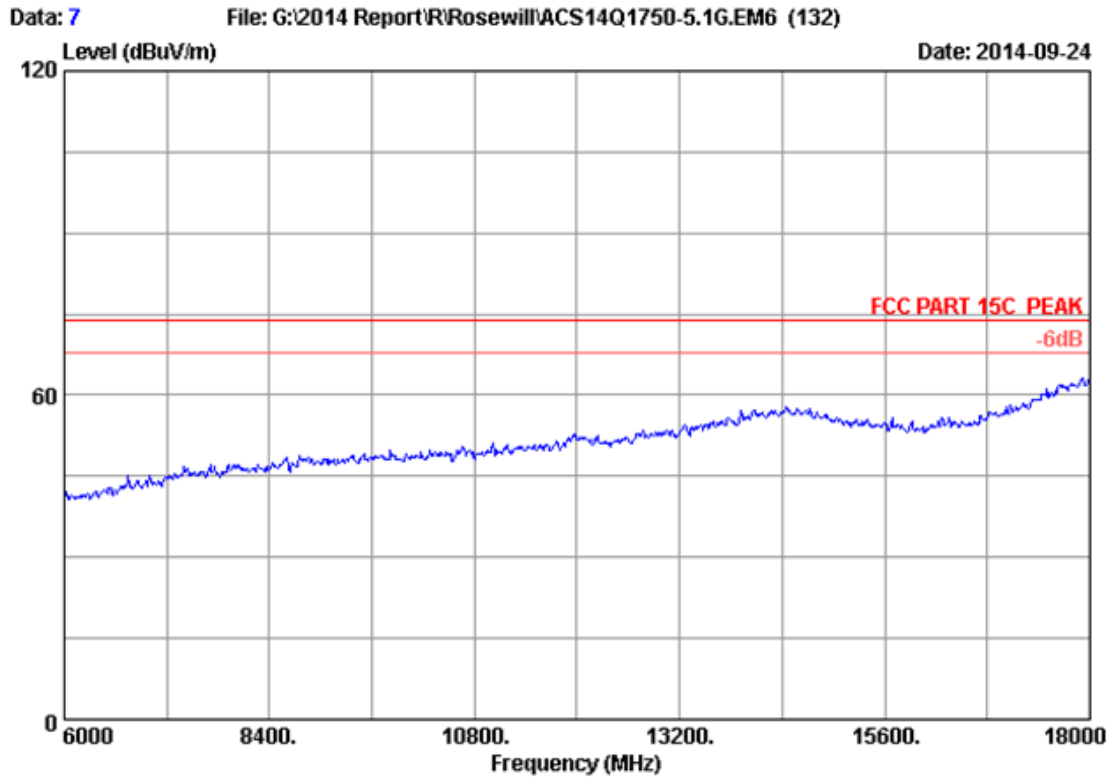

Site no. : 3m Chamber Data no. : 7
Dis. / Ant. : 3m 2014 3115 (4580) Ant. pol. : VERTICAL
Limit : FCC PART 15C PEAK
Env. / Ins. : 24°C/56% Engineer : Leo-Li
EUT : AC750 Wireless Dual Band Gigabit Router
Power Rating : DC 12V From Adapter Input AC 120V/60Hz
Test Mode : IEEE802.11a 5180MHz Tx
M/N : RNX-AC750RT

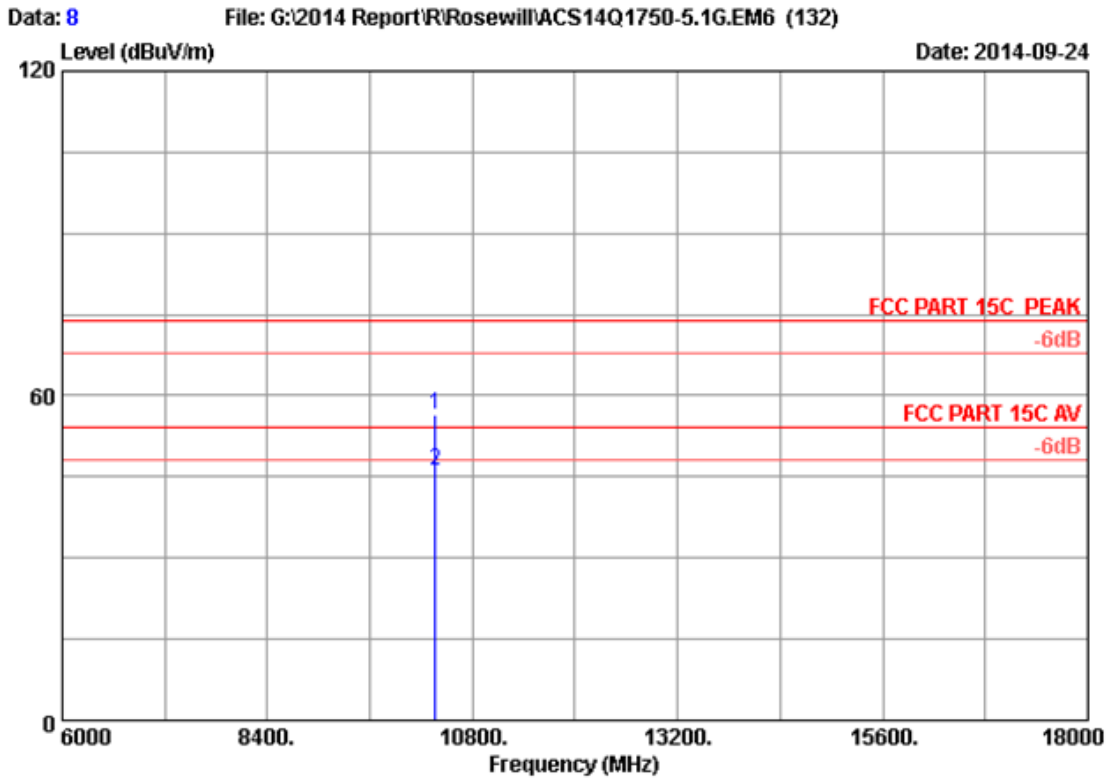

Site no. : 3m Chamber Data no. : 8
 Dis. / Ant. : 3m 2014 3115 (4580) Ant. pol. : VERTICAL
 Limit : FCC PART 15C PEAK
 Env. / Ins. : 24°C/56% Engineer : Leo-Li
 EUT : AC750 Wireless Dual Band Gigabit Router
 Power Rating : DC 12V From Adapter Input AC 120V/60Hz
 Test Mode : IEEE802.11a 5180MHz Tx
 M/N : RNX-AC750RT

No.	Freq. (MHz)	Ant. Factor (dB/m)	Cable Loss (dB)	AMP factor (dB)	Reading (dBuV)	Emission Level (dBuV/m)	Limits (dBuV/m)	Margin (dB)	Remark
1	10360.000	38.14	12.64	35.45	41.11	56.44	74.00	17.56	Peak
2	10360.000	38.14	12.64	35.45	30.96	46.29	54.00	7.71	Average

Remarks: 1. Emission Level= Antenna Factor + Cable Loss + Reading - Amp Factor
 2. The emission levels that are 20dB below the official limit are not reported.

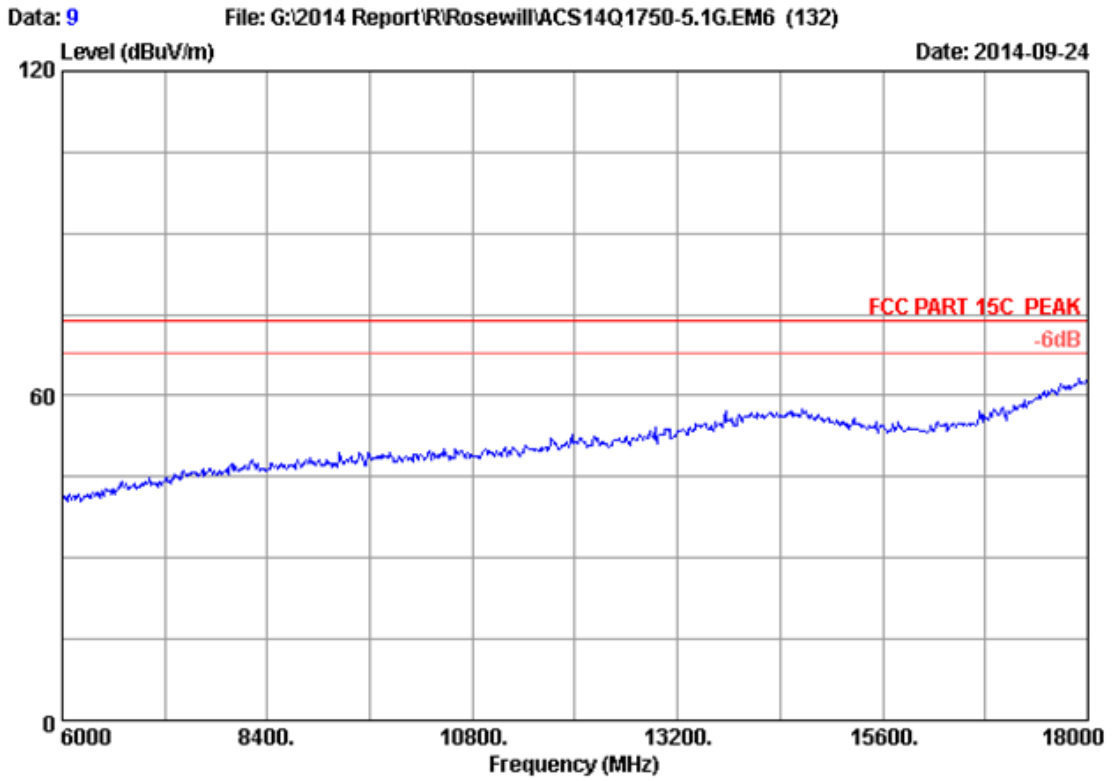

Site no. : 3m Chamber Data no. : 9
Dis. / Ant. : 3m 2014 3115 (4580) Ant. pol. : HORIZONTAL
Limit : FCC PART 15C PEAK
Env. / Ins. : 24°C/56% Engineer : Leo-Li
EUT : AC750 Wireless Dual Band Gigabit Router
Power Rating : DC 12V From Adapter Input AC 120V/60Hz
Test Mode : IEEE802.11a 5180MHz Tx
M/N : RNX-AC750RT

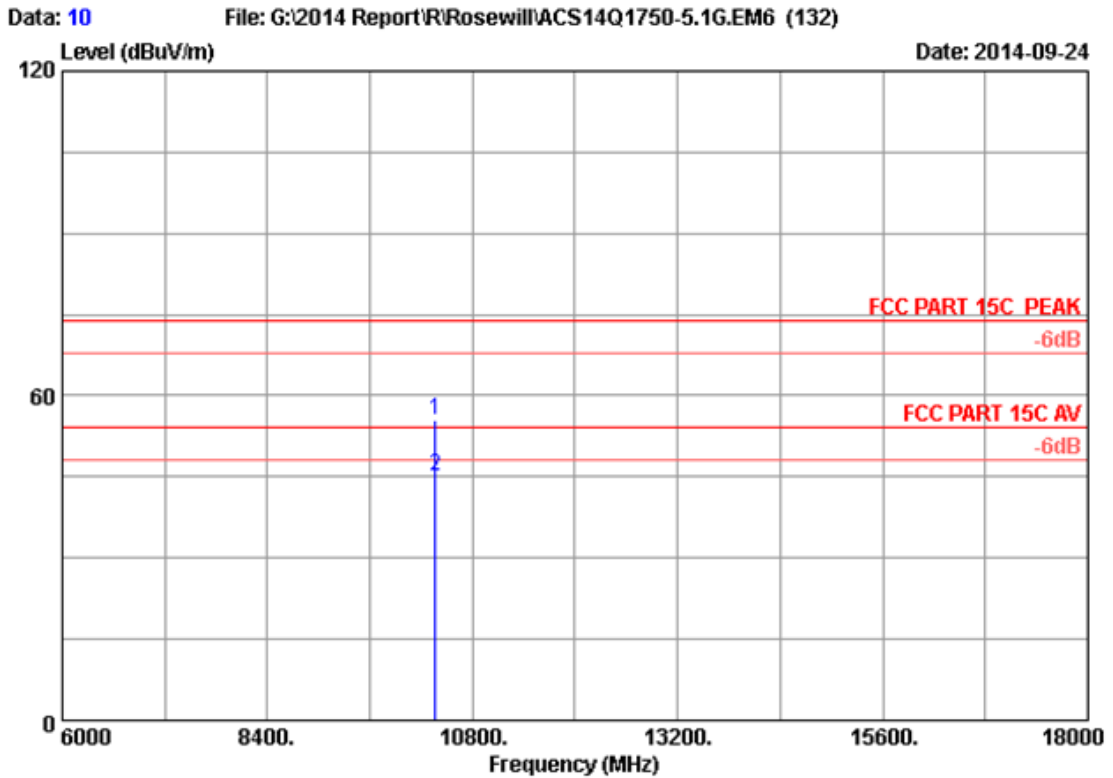

Site no. : 3m Chamber Data no. : 10
 Dis. / Ant. : 3m 2014 3115 (4580) Ant. pol. : HORIZONTAL
 Limit : FCC PART 15C PEAK
 Env. / Ins. : 24°C/56% Engineer : Leo-Li
 EUT : AC750 Wireless Dual Band Gigabit Router
 Power Rating : DC 12V From Adapter Input AC 120V/60Hz
 Test Mode : IEEE802.11a 5180MHz Tx
 M/N : RNX-AC750RT

No.	Freq. (MHz)	Ant. Factor (dB/m)	Cable Loss (dB)	AMP factor (dB)	Reading (dBuV)	Emission Level (dBuV/m)	Limits (dBuV/m)	Margin (dB)	Remark
1	10360.000	38.14	12.64	35.45	40.04	55.37	74.00	18.63	Peak
2	10360.000	38.14	12.64	35.45	29.71	45.04	54.00	8.96	Average

Remarks: 1. Emission Level= Antenna Factor + Cable Loss + Reading - Amp Factor
 2. The emission levels that are 20dB below the official limit are not reported.

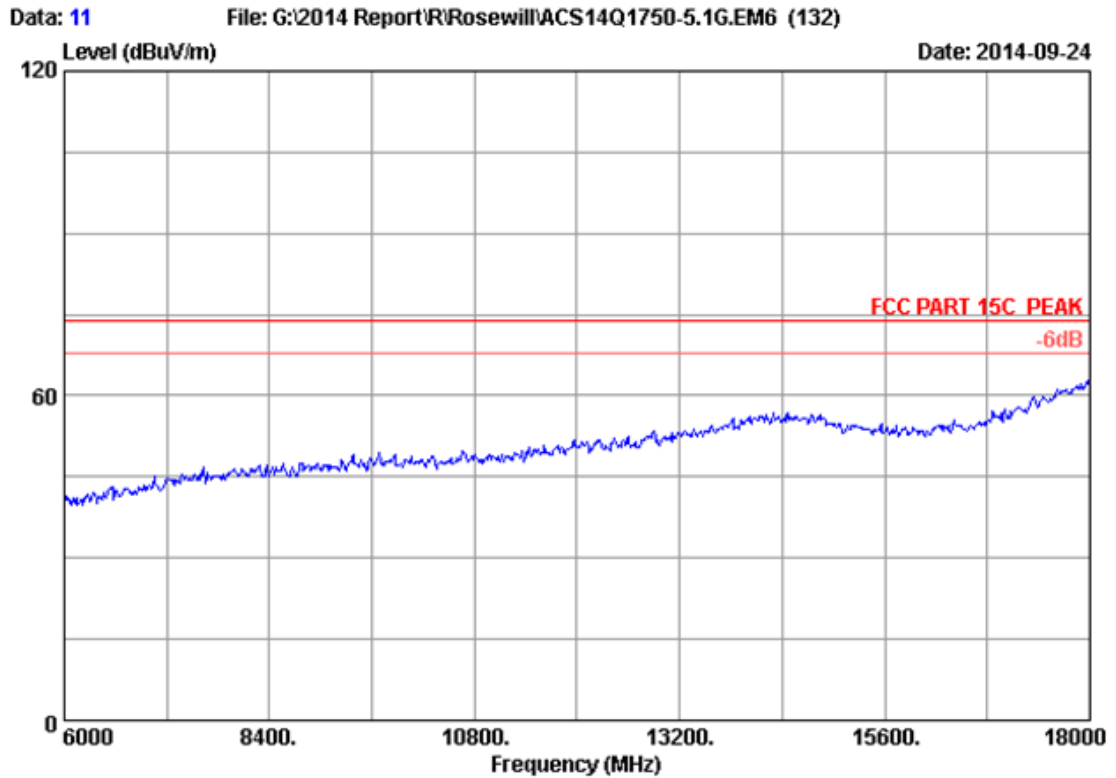

Site no. : 3m Chamber Data no. : 11
Dis. / Ant. : 3m 2014 3115 (4580) Ant. pol. : HORIZONTAL
Limit : FCC PART 15C PEAK
Env. / Ins. : 24°C/56% Engineer : Leo-Li
EUT : AC750 Wireless Dual Band Gigabit Router
Power Rating : DC 12V From Adapter Input AC 120V/60Hz
Test Mode : IEEE802.11a 5200MHz Tx
M/N : RNX-AC750RT

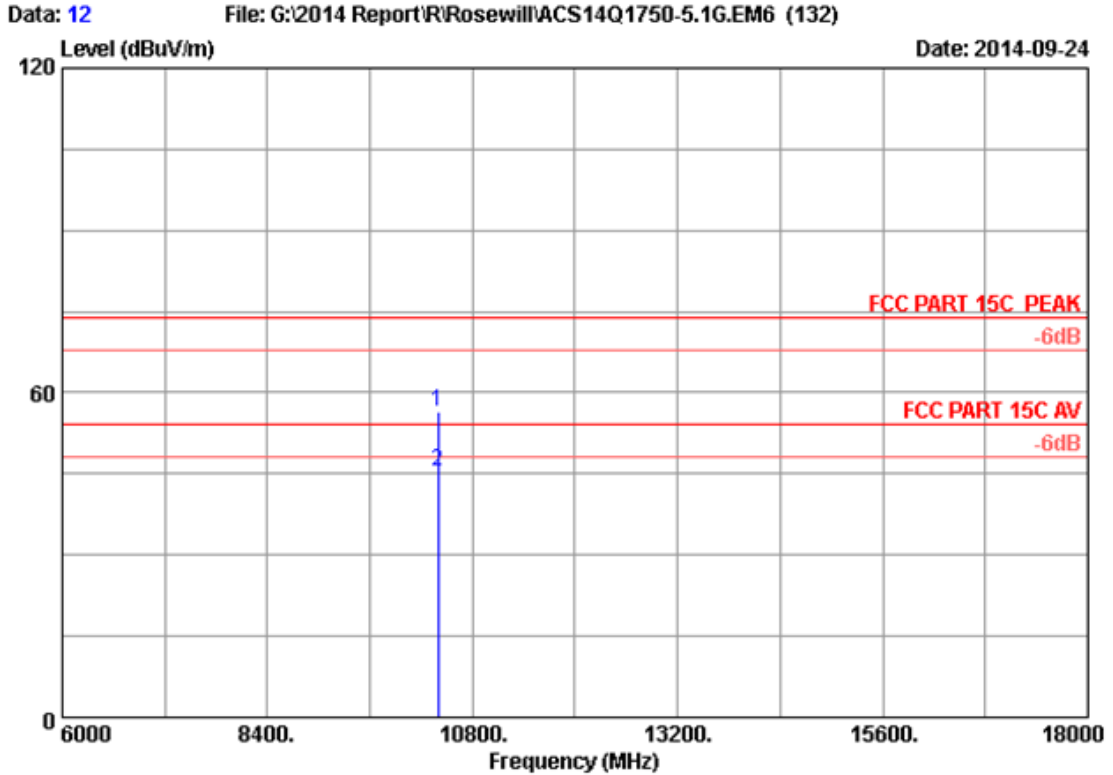

Site no. : 3m Chamber Data no. : 12
 Dis. / Ant. : 3m 2014 3115 (4580) Ant. pol. : HORIZONTAL
 Limit : FCC PART 15C PEAK
 Env. / Ins. : 24°C/56% Engineer : Leo-Li
 EUT : AC750 Wireless Dual Band Gigabit Router
 Power Rating : DC 12V From Adapter Input AC 120V/60Hz
 Test Mode : IEEE802.11a 5200MHz Tx
 M/N : RNX-AC750RT

No.	Freq. (MHz)	Ant. Factor (dB/m)	Cable Loss (dB)	AMP factor (dB)	Reading (dBuV)	Emission Level (dBuV/m)	Limits (dBuV/m)	Margin (dB)	Remark
1	10400.000	38.16	12.66	35.44	41.03	56.41	74.00	17.59	Peak
2	10400.000	38.16	12.66	35.44	30.10	45.48	54.00	8.52	Average

Remarks: 1. Emission Level= Antenna Factor + Cable Loss + Reading - Amp Factor
 2. The emission levels that are 20dB below the official limit are not reported.

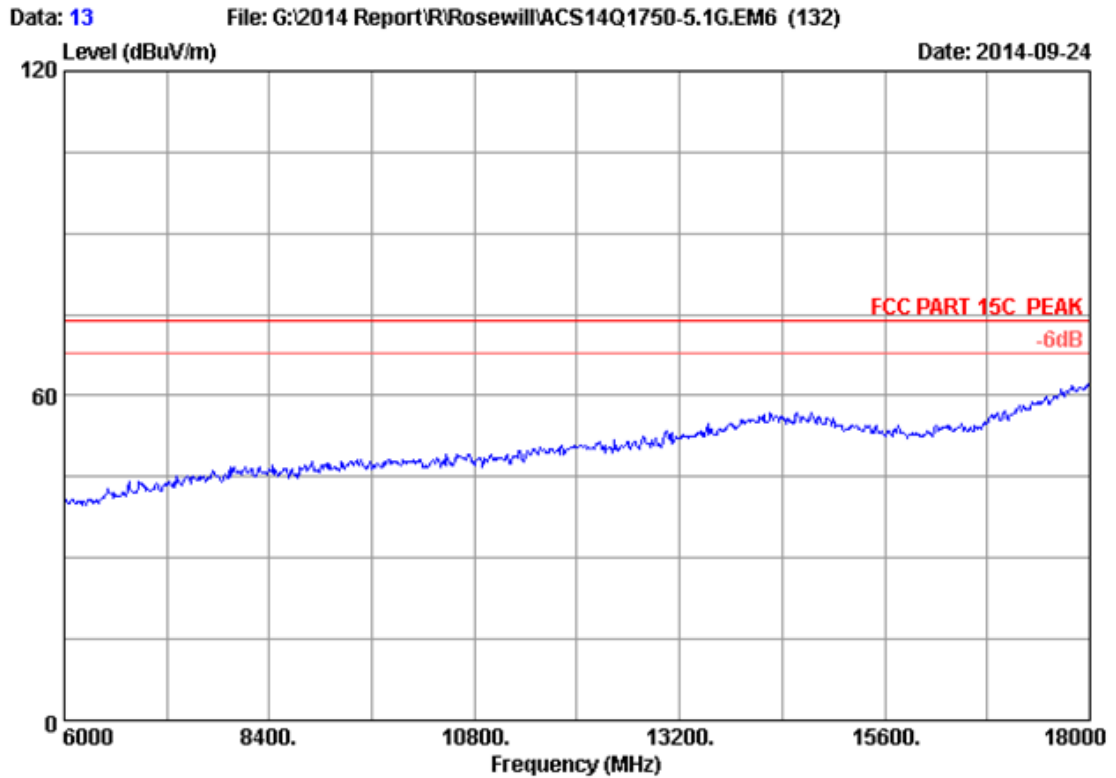

Site no. : 3m Chamber Data no. : 13
Dis. / Ant. : 3m 2014 3115 (4580) Ant. pol. : VERTICAL
Limit : FCC PART 15C PEAK
Env. / Ins. : 24°C/56% Engineer : Leo-Li
EUT : AC750 Wireless Dual Band Gigabit Router
Power Rating : DC 12V From Adapter Input AC 120V/60Hz
Test Mode : IEEE802.11a 5200MHz Tx
M/N : RNX-AC750RT

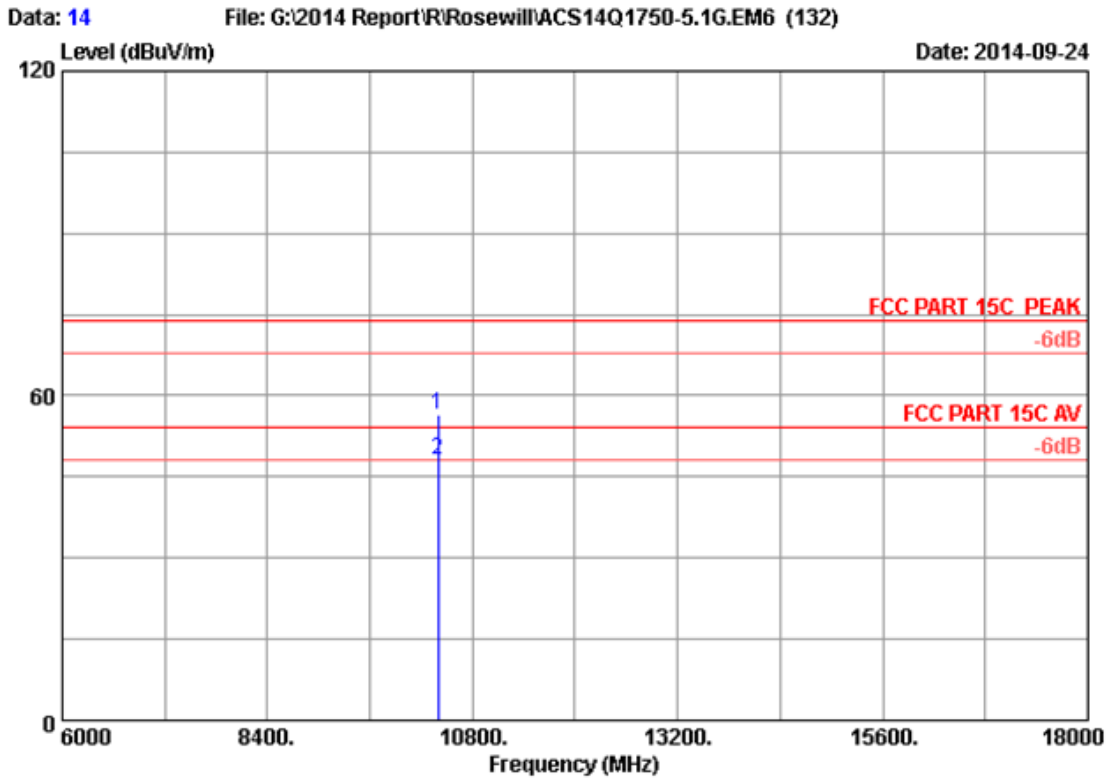

Site no. : 3m Chamber Data no. : 14
 Dis. / Ant. : 3m 2014 3115 (4580) Ant. pol. : VERTICAL
 Limit : FCC PART 15C PEAK
 Env. / Ins. : 24°C/56% Engineer : Leo-Li
 EUT : AC750 Wireless Dual Band Gigabit Router
 Power Rating : DC 12V From Adapter Input AC 120V/60Hz
 Test Mode : IEEE802.11a 5200MHz Tx
 M/N : RNX-AC750RT

No.	Freq. (MHz)	Ant. Factor (dB/m)	Cable Loss (dB)	AMP factor (dB)	Reading (dBuV)	Emission Level (dBuV/m)	Limits (dBuV/m)	Margin (dB)	Remark
1	10400.000	38.16	12.66	35.44	41.13	56.51	74.00	17.49	Peak
2	10400.000	38.16	12.66	35.44	32.81	48.19	54.00	5.81	Average

Remarks: 1. Emission Level= Antenna Factor + Cable Loss + Reading - Amp Factor
 2. The emission levels that are 20dB below the official limit are not reported.

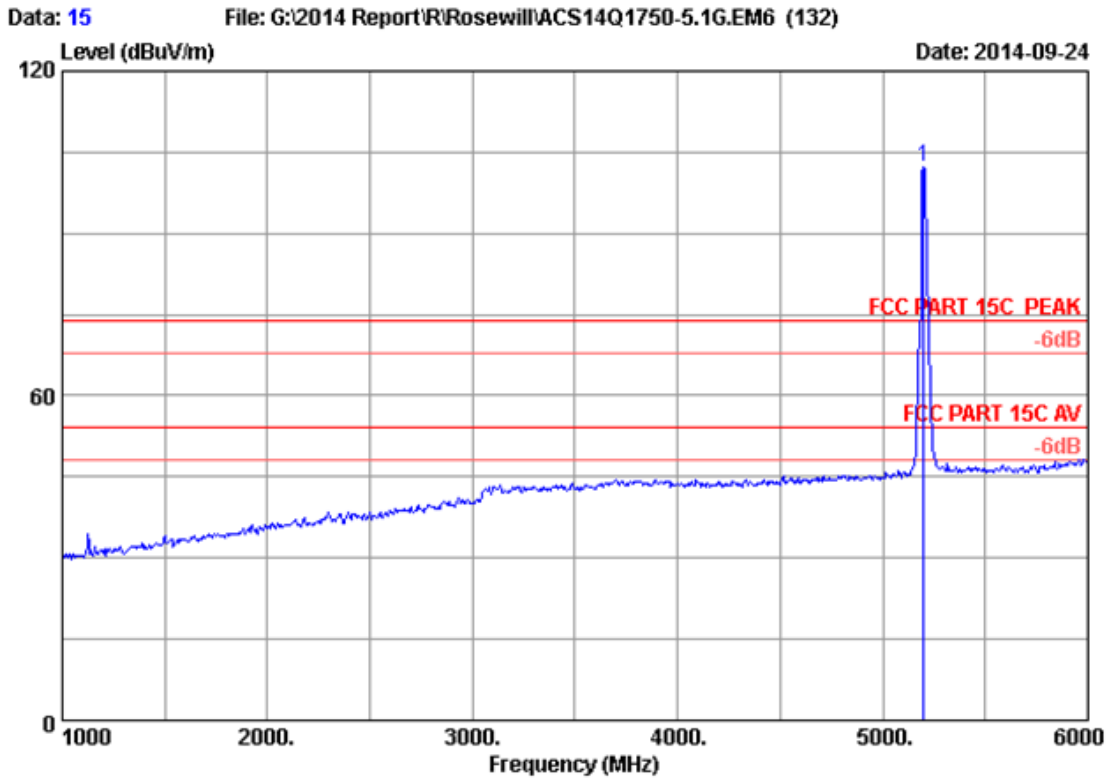

Site no. : 3m Chamber Data no. : 15
 Dis. / Ant. : 3m 2014 3115 (4580) Ant. pol. : VERTICAL
 Limit : FCC PART 15C PEAK
 Env. / Ins. : 24°C/56% Engineer : Leo-Li
 EUT : AC750 Wireless Dual Band Gigabit Router
 Power Rating : DC 12V From Adapter Input AC 120V/60Hz
 Test Mode : IEEE802.11a 5200MHz Tx
 M/N : RNX-AC750RT

No.	Freq. (MHz)	Ant. Factor (dB/m)	Cable Loss (dB)	AMP factor (dB)	Reading (dBuV)	Emission Level (dBuV/m)	Limits (dBuV/m)	Margin (dB)	Remark
1	5200.000	33.52	8.97	35.70	95.40	102.19	74.00	-28.19	Peak

Remarks: 1. Emission Level= Antenna Factor + Cable Loss + Reading - Amp Factor
 2. The emission levels that are 20dB below the official limit are not reported.

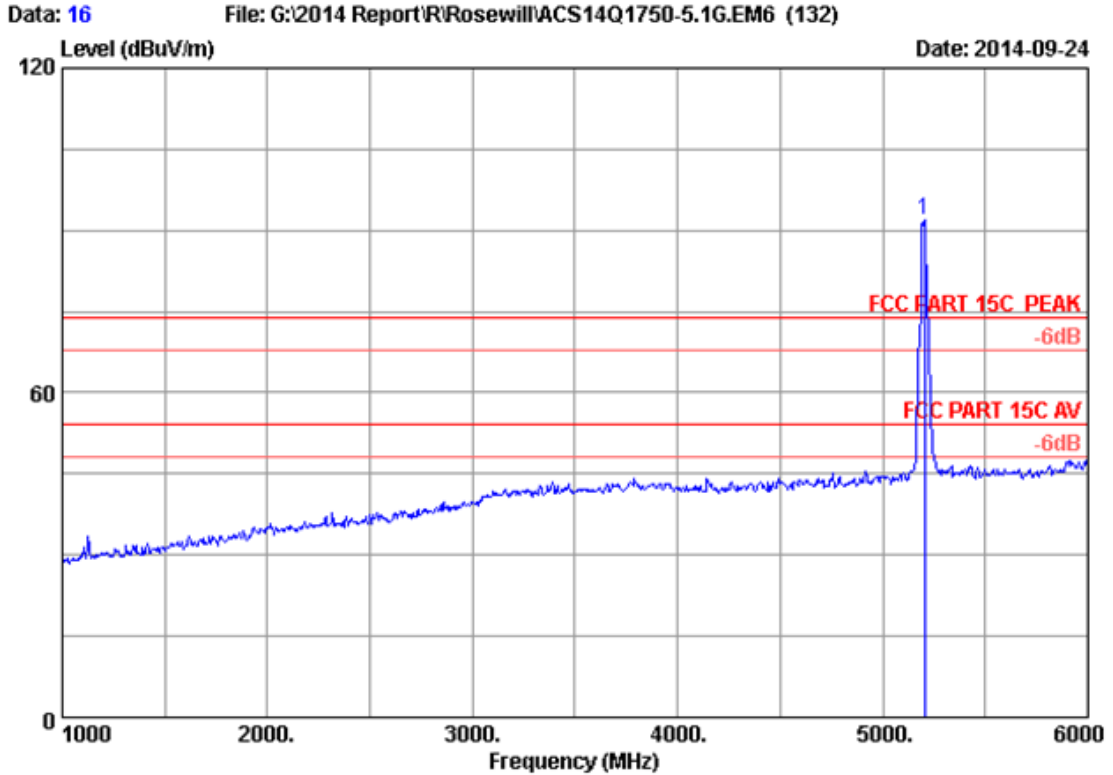

Site no. : 3m Chamber Data no. : 16
 Dis. / Ant. : 3m 2014 3115 (4580) Ant. pol. : HORIZONTAL
 Limit : FCC PART 15C PEAK
 Env. / Ins. : 24°C/56% Engineer : Leo-Li
 EUT : AC750 Wireless Dual Band Gigabit Router
 Power Rating : DC 12V From Adapter Input AC 120V/60Hz
 Test Mode : IEEE802.11a 5200MHz Tx
 M/N : RNX-AC750RT

No.	Freq. (MHz)	Ant. Factor (dB/m)	Cable Loss (dB)	AMP factor (dB)	Reading (dBuV)	Emission Level (dBuV/m)	Limits (dBuV/m)	Margin (dB)	Remark
1	5205.000	33.53	8.98	35.70	84.96	91.77	74.00	-17.77	Peak

Remarks: 1. Emission Level= Antenna Factor + Cable Loss + Reading - Amp Factor
 2. The emission levels that are 20dB below the official limit are not reported.

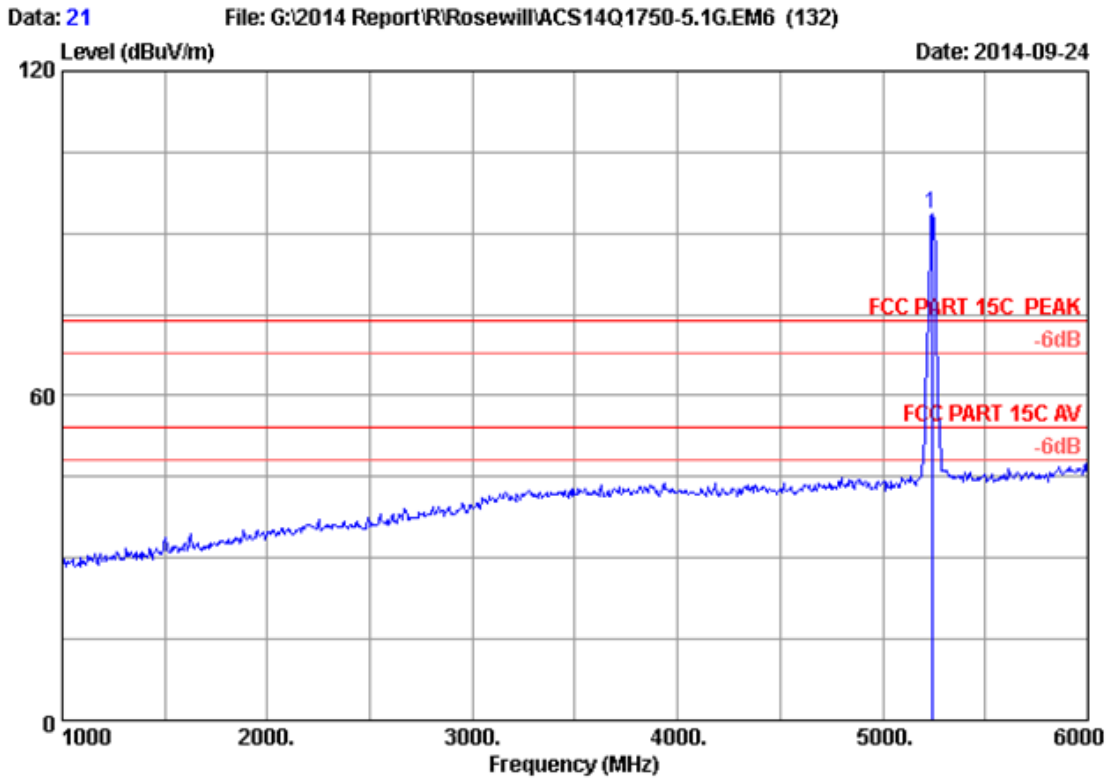

Site no. : 3m Chamber Data no. : 21
 Dis. / Ant. : 3m 2014 3115 (4580) Ant. pol. : HORIZONTAL
 Limit : FCC PART 15C PEAK
 Env. / Ins. : 24°C/56% Engineer : Leo-Li
 EUT : AC750 Wireless Dual Band Gigabit Router
 Power Rating : DC 12V From Adapter Input AC 120V/60Hz
 Test Mode : IEEE802.11a 5240MHz Tx
 M/N : RNX-AC750RT

No.	Freq. (MHz)	Ant. Factor (dB/m)	Cable Loss (dB)	AMP factor (dB)	Reading (dBuV)	Emission Level (dBuV/m)	Limits (dBuV/m)	Margin (dB)	Remark
1	5240.000	33.58	9.02	35.70	86.54	93.44	74.00	-19.44	Peak

Remarks: 1. Emission Level= Antenna Factor + Cable Loss + Reading - Amp Factor
 2. The emission levels that are 20dB below the official limit are not reported.

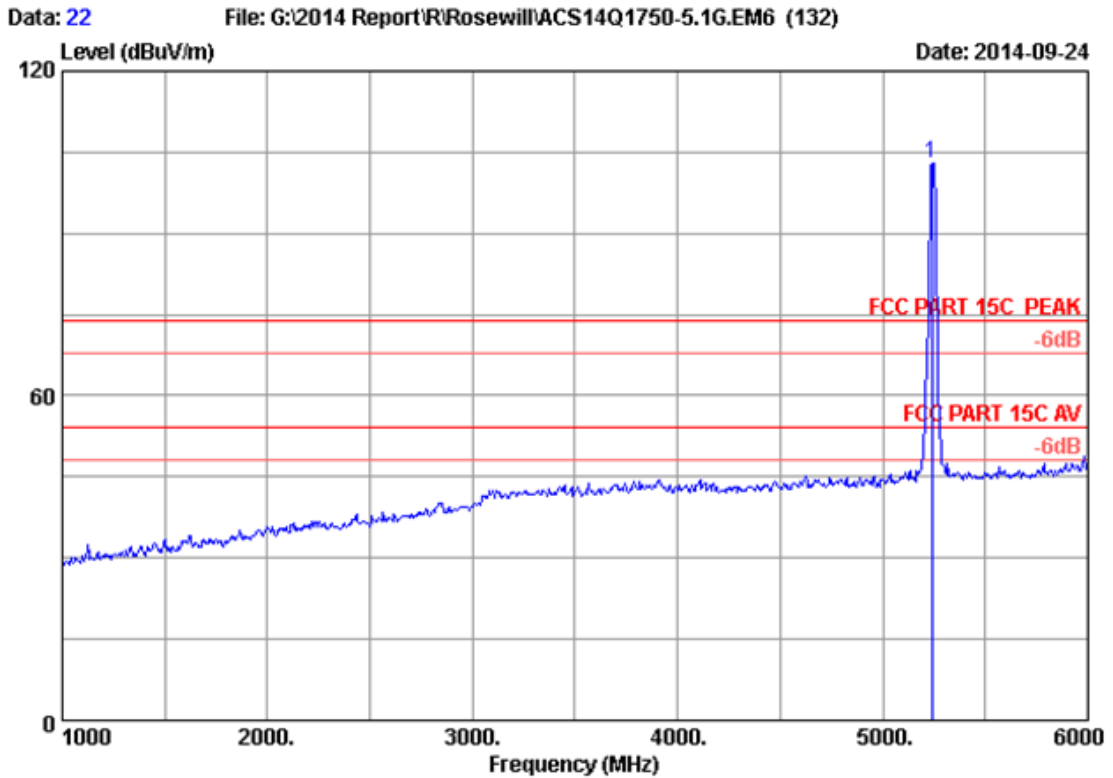

Site no. : 3m Chamber Data no. : 22
 Dis. / Ant. : 3m 2014 3115 (4580) Ant. pol. : VERTICAL
 Limit : FCC PART 15C PEAK
 Env. / Ins. : 24°C/56% Engineer : Leo-Li
 EUT : AC750 Wireless Dual Band Gigabit Router
 Power Rating : DC 12V From Adapter Input AC 120V/60Hz
 Test Mode : IEEE802.11a 5240MHz Tx
 M/N : RNX-AC750RT

No.	Freq. (MHz)	Ant. Factor (dB/m)	Cable Loss (dB)	AMP factor (dB)	Reading (dBuV)	Emission Level (dBuV/m)	Limits (dBuV/m)	Margin (dB)	Remark
1	5240.000	33.58	9.02	35.70	96.20	103.10	74.00	-29.10	Peak

Remarks: 1. Emission Level= Antenna Factor + Cable Loss + Reading - Amp Factor
 2. The emission levels that are 20dB below the official limit are not reported.

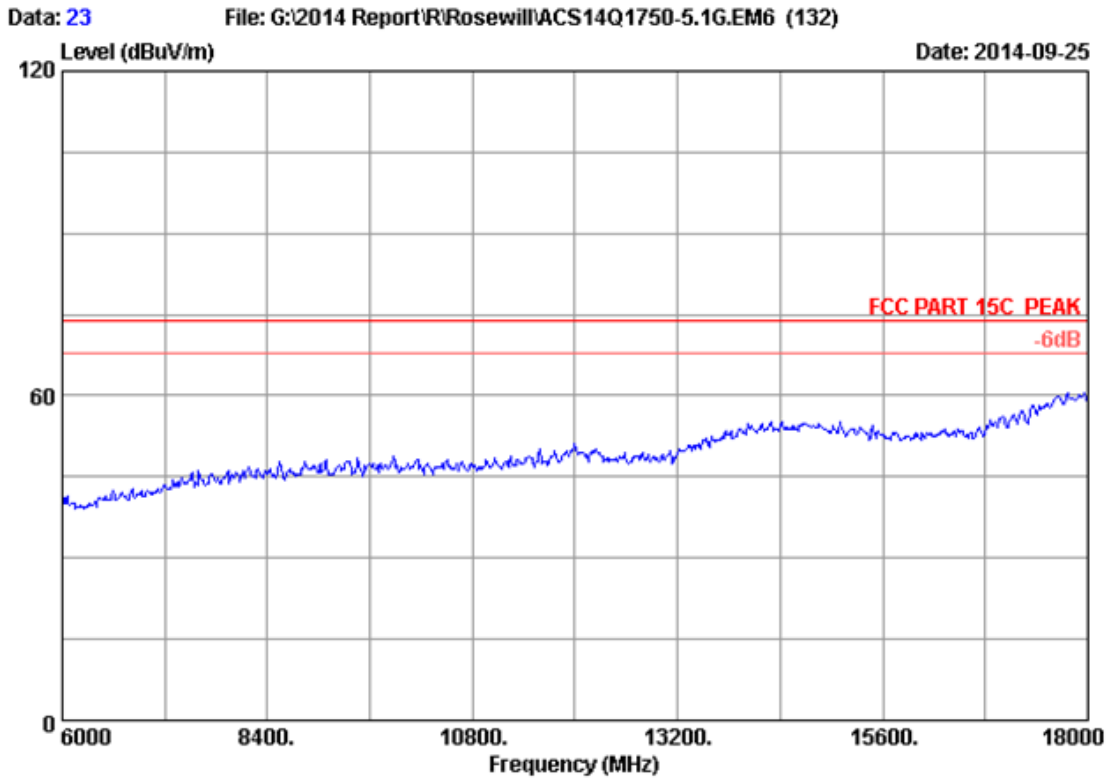

Site no. : 3m Chamber Data no. : 23
Dis. / Ant. : 3m 2014 3115 (4580) Ant. pol. : HORIZONTAL
Limit : FCC PART 15C PEAK
Env. / Ins. : 24*C/56% Engineer : Leo-Li
EUT : AC750 Wireless Dual Band Gigabit Router
Power Rating : DC 12V From Adapter Input AC 120V/60Hz
Test Mode : IEEE802.11a 5240MHz Tx
M/N : RNX-AC750RT

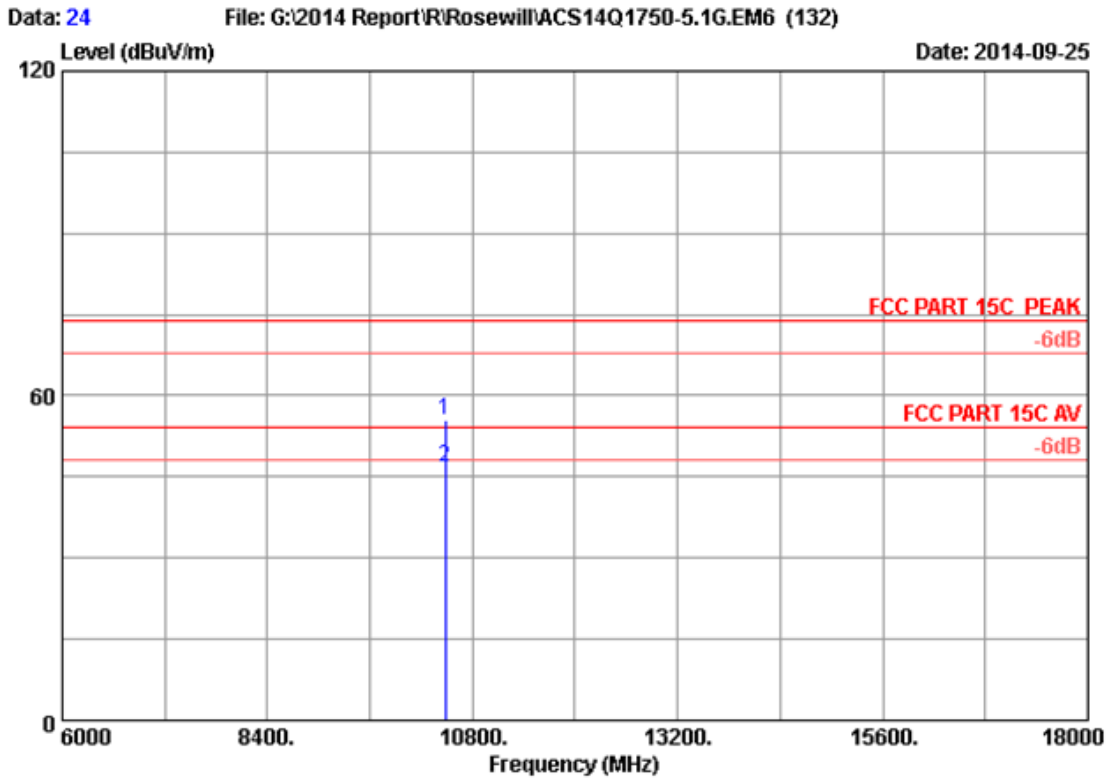

Site no. : 3m Chamber Data no. : 24
 Dis. / Ant. : 3m 2014 3115 (4580) Ant. pol. : HORIZONTAL
 Limit : FCC PART 15C PEAK
 Env. / Ins. : 24°C/56% Engineer : Leo-Li
 EUT : AC750 Wireless Dual Band Gigabit Router
 Power Rating : DC 12V From Adapter Input AC 120V/60Hz
 Test Mode : IEEE802.11a 5240MHz Tx
 M/N : RNX-AC750RT

No.	Freq. (MHz)	Ant. Factor (dB/m)	Cable Loss (dB)	AMP factor (dB)	Reading (dBuV)	Emission Level (dBuV/m)	Limits (dBuV/m)	Margin (dB)	Remark
1	10480.000	38.19	12.70	35.43	39.87	55.33	74.00	18.67	Peak
2	10480.000	38.19	12.70	35.43	31.18	46.64	54.00	7.36	Average

Remarks: 1. Emission Level= Antenna Factor + Cable Loss + Reading - Amp Factor
 2. The emission levels that are 20dB below the official limit are not reported.

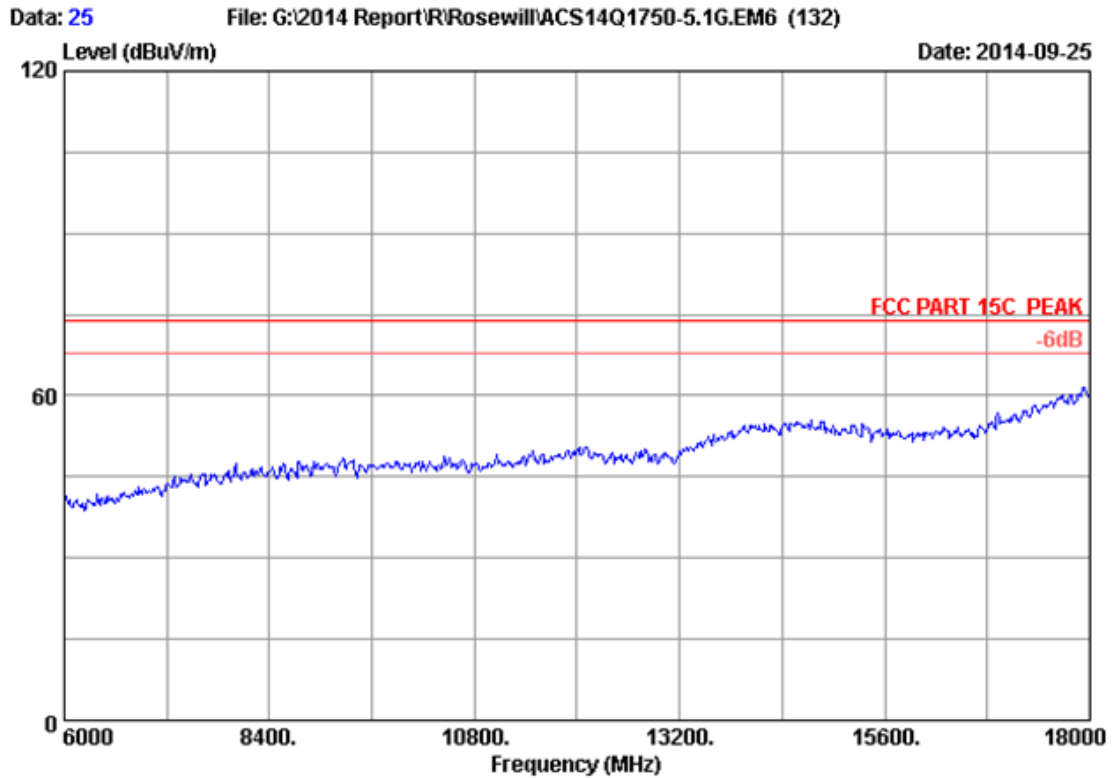

Site no. : 3m Chamber Data no. : 25
Dis. / Ant. : 3m 2014 3115 (4580) Ant. pol. : VERTICAL
Limit : FCC PART 15C PEAK
Env. / Ins. : 24°C/56% Engineer : Leo-Li
EUT : AC750 Wireless Dual Band Gigabit Router
Power Rating : DC 12V From Adapter Input AC 120V/60Hz
Test Mode : IEEE802.11a 5240MHz Tx
M/N : RNX-AC750RT

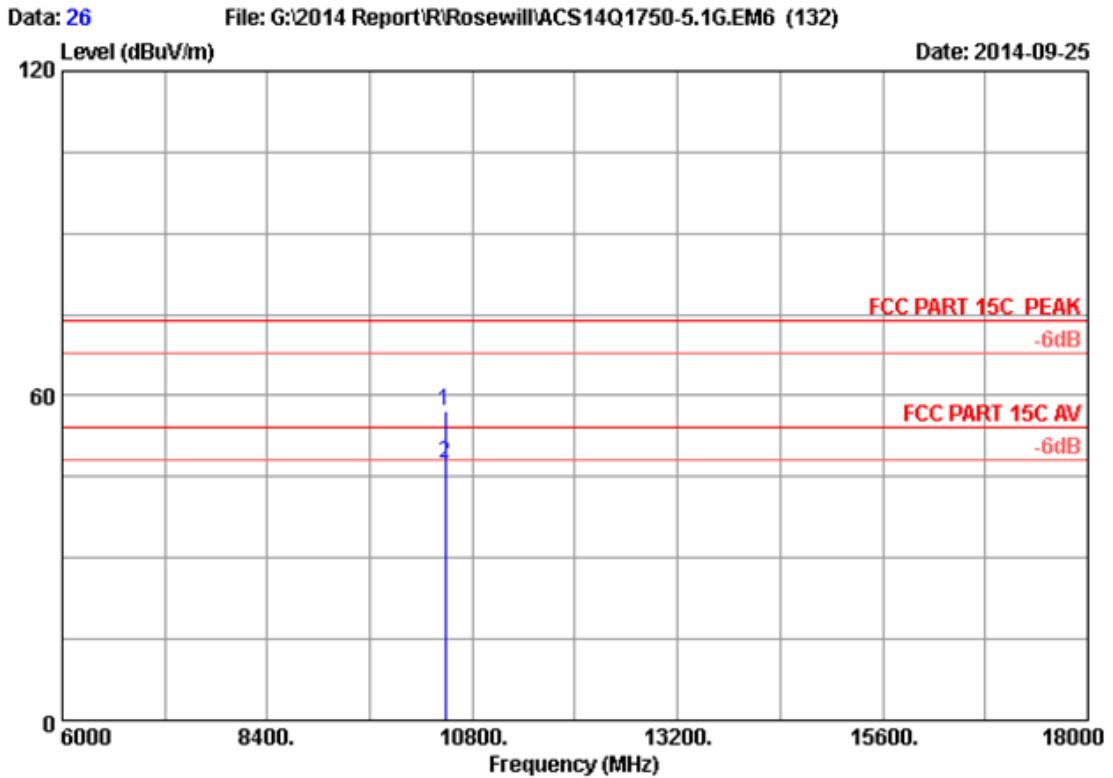

Site no. : 3m Chamber Data no. : 26
 Dis. / Ant. : 3m 2014 3115 (4580) Ant. pol. : VERTICAL
 Limit : FCC PART 15C PEAK
 Env. / Ins. : 24°C/56% Engineer : Leo-Li
 EUT : AC750 Wireless Dual Band Gigabit Router
 Power Rating : DC 12V From Adapter Input AC 120V/60Hz
 Test Mode : IEEE802.11a 5240MHz Tx
 M/N : RNX-AC750RT

No.	Freq. (MHz)	Ant. Factor (dB/m)	Cable Loss (dB)	AMP factor (dB)	Reading (dBuV)	Emission Level (dBuV/m)	Limits (dBuV/m)	Margin (dB)	Remark
1	10480.000	38.19	12.70	35.43	41.68	57.14	74.00	16.86	Peak
2	10480.000	38.19	12.70	35.43	32.05	47.51	54.00	6.49	Average

Remarks: 1. Emission Level= Antenna Factor + Cable Loss + Reading - Amp Factor
 2. The emission levels that are 20dB below the official limit are not reported.

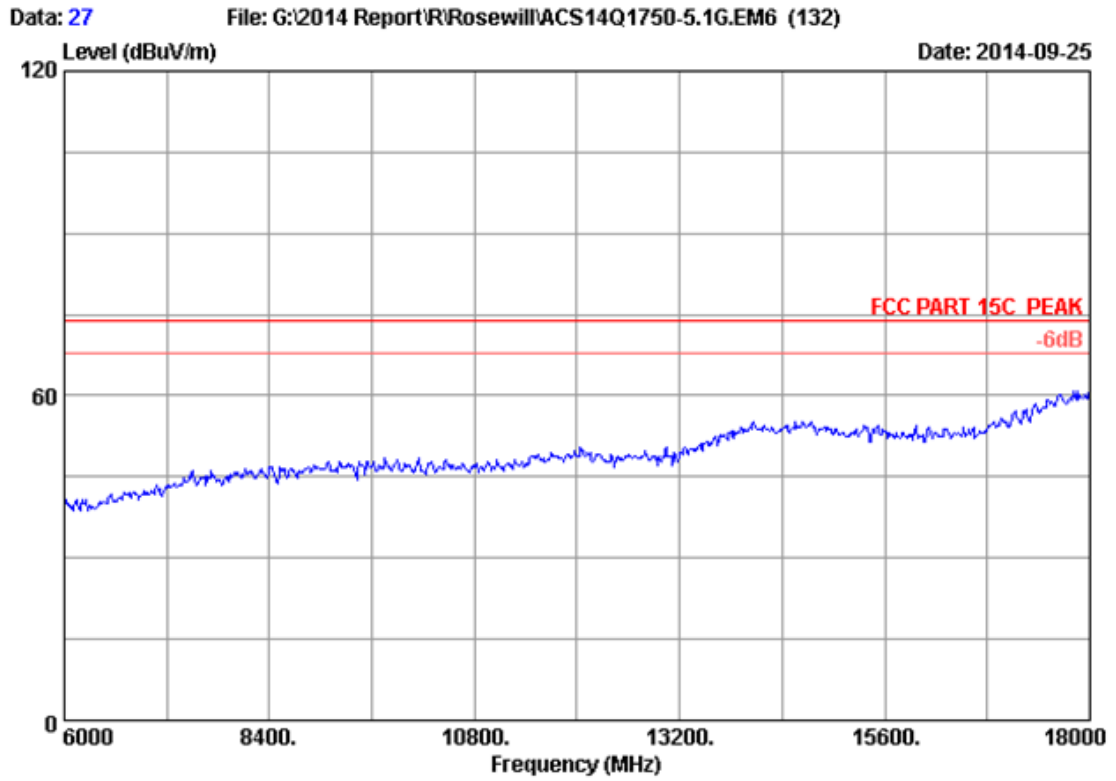

Site no. : 3m Chamber Data no. : 27
Dis. / Ant. : 3m 2014 3115 (4580) Ant. pol. : VERTICAL
Limit : FCC PART 15C PEAK
Env. / Ins. : 24°C/56% Engineer : Leo-Li
EUT : AC750 Wireless Dual Band Gigabit Router
Power Rating : DC 12V From Adapter Input AC 120V/60Hz
Test Mode : IEEE802.11nHT20 5240MHz Tx
M/N : RNX-AC750RT

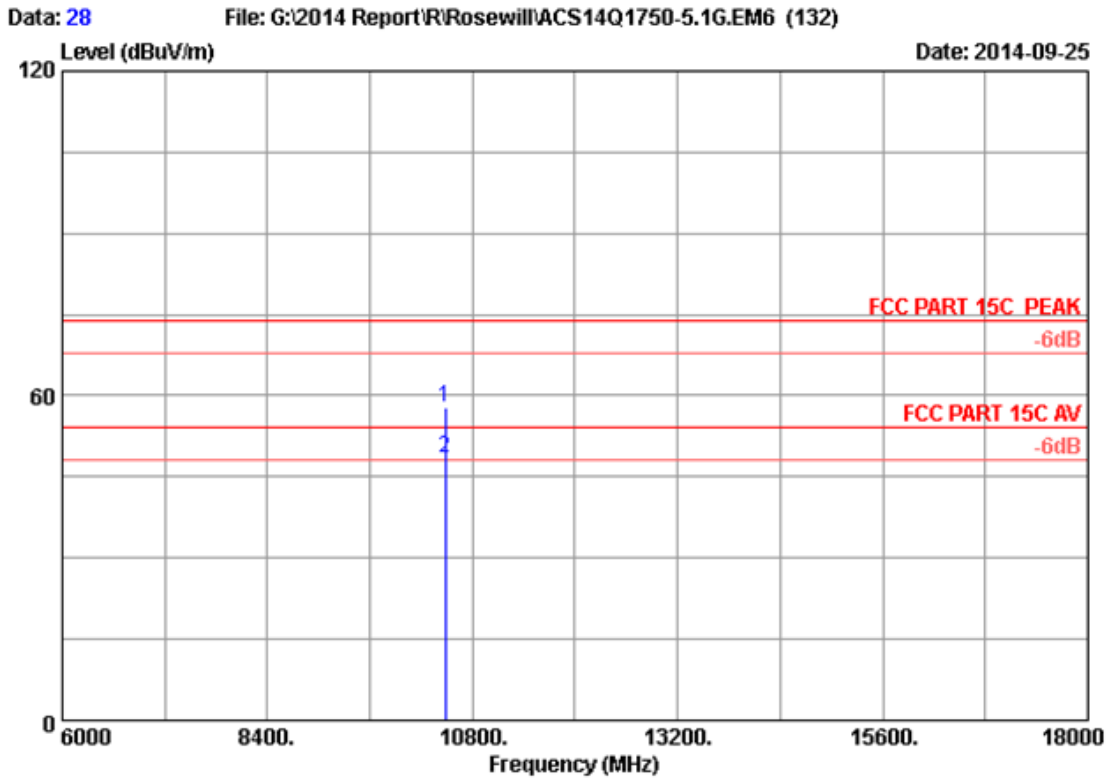

Site no. : 3m Chamber Data no. : 28
 Dis. / Ant. : 3m 2014 3115 (4580) Ant. pol. : VERTICAL
 Limit : FCC PART 15C PEAK
 Env. / Ins. : 24°C/56% Engineer : Leo-Li
 EUT : AC750 Wireless Dual Band Gigabit Router
 Power Rating : DC 12V From Adapter Input AC 120V/60Hz
 Test Mode : IEEE802.11nHT20 5240MHz Tx
 M/N : RNX-AC750RT

No.	Freq. (MHz)	Ant. Factor (dB/m)	Cable Loss (dB)	AMP factor (dB)	Reading (dBuV)	Emission Level (dBuV/m)	Limits (dBuV/m)	Margin (dB)	Remark
1	10480.000	38.19	12.70	35.43	42.36	57.82	74.00	16.18	Peak
2	10480.000	38.19	12.70	35.43	33.13	48.59	54.00	5.41	Average

Remarks: 1. Emission Level= Antenna Factor + Cable Loss + Reading - Amp Factor
 2. The emission levels that are 20dB below the official limit are not reported.

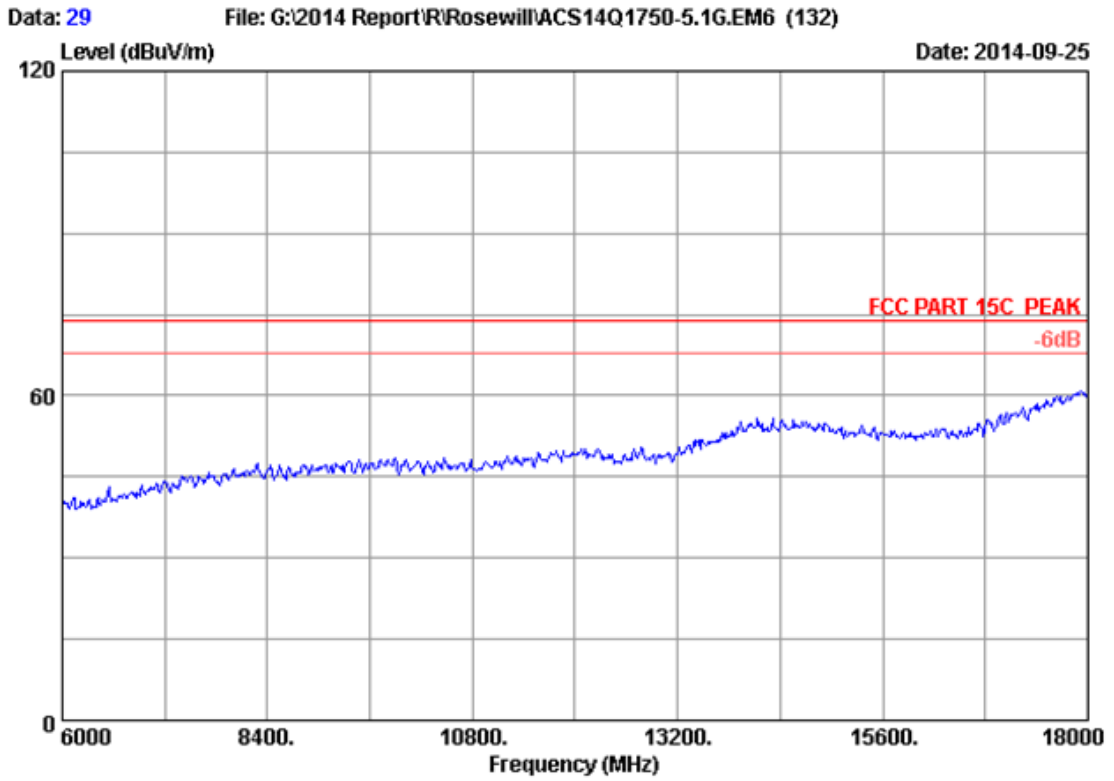

Site no. : 3m Chamber Data no. : 29
Dis. / Ant. : 3m 2014 3115 (4580) Ant. pol. : HORIZONTAL
Limit : FCC PART 15C PEAK
Env. / Ins. : 24°C/56% Engineer : Leo-Li
EUT : AC750 Wireless Dual Band Gigabit Router
Power Rating : DC 12V From Adapter Input AC 120V/60Hz
Test Mode : IEEE802.11nHT20 5240MHz Tx
M/N : RNX-AC750RT

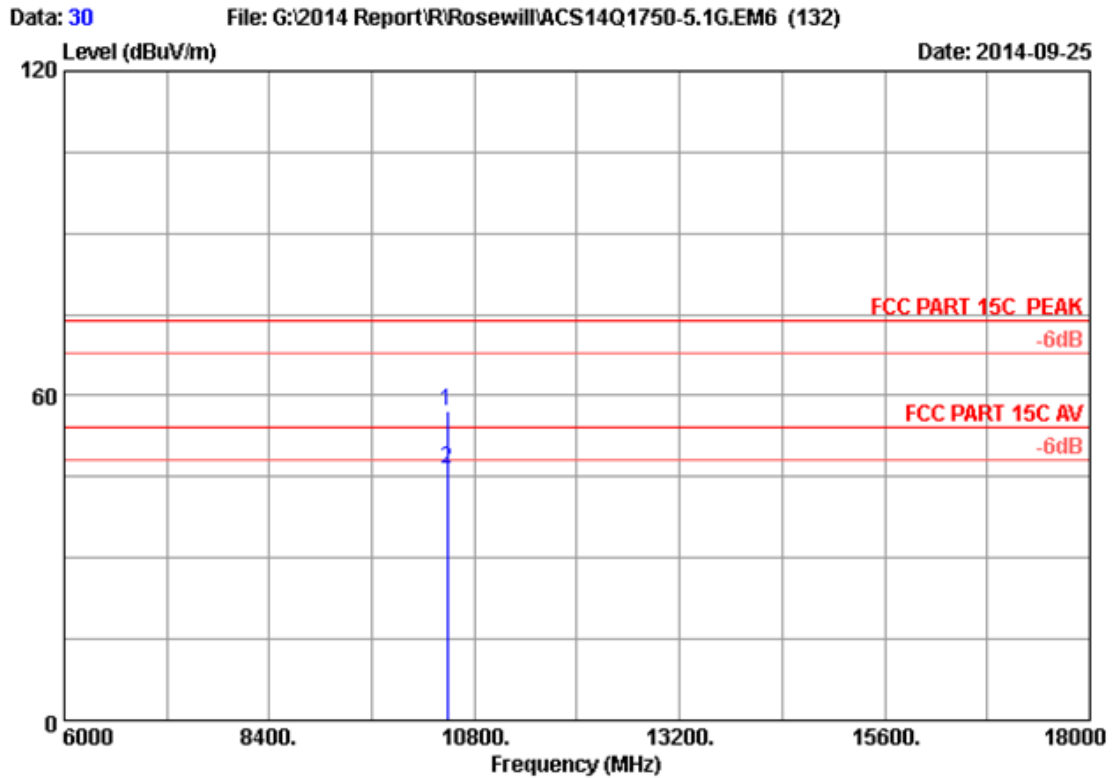

Site no. : 3m Chamber Data no. : 30
 Dis. / Ant. : 3m 2014 3115 (4580) Ant. pol. : HORIZONTAL
 Limit : FCC PART 15C PEAK
 Env. / Ins. : 24°C/56% Engineer : Leo-Li
 EUT : AC750 Wireless Dual Band Gigabit Router
 Power Rating : DC 12V From Adapter Input AC 120V/60Hz
 Test Mode : IEEE802.11nHT20 5240MHz Tx
 M/N : RNX-AC750RT

No.	Freq. (MHz)	Ant. Factor (dB/m)	Cable Loss (dB)	AMP factor (dB)	Reading (dBuV)	Emission Level (dBuV/m)	Limits (dBuV/m)	Margin (dB)	Remark
1	10480.000	38.19	12.70	35.43	41.63	57.09	74.00	16.91	Peak
2	10480.000	38.19	12.70	35.43	31.05	46.51	54.00	7.49	Average

Remarks: 1. Emission Level= Antenna Factor + Cable Loss + Reading - Amp Factor
 2. The emission levels that are 20dB below the official limit are not reported.

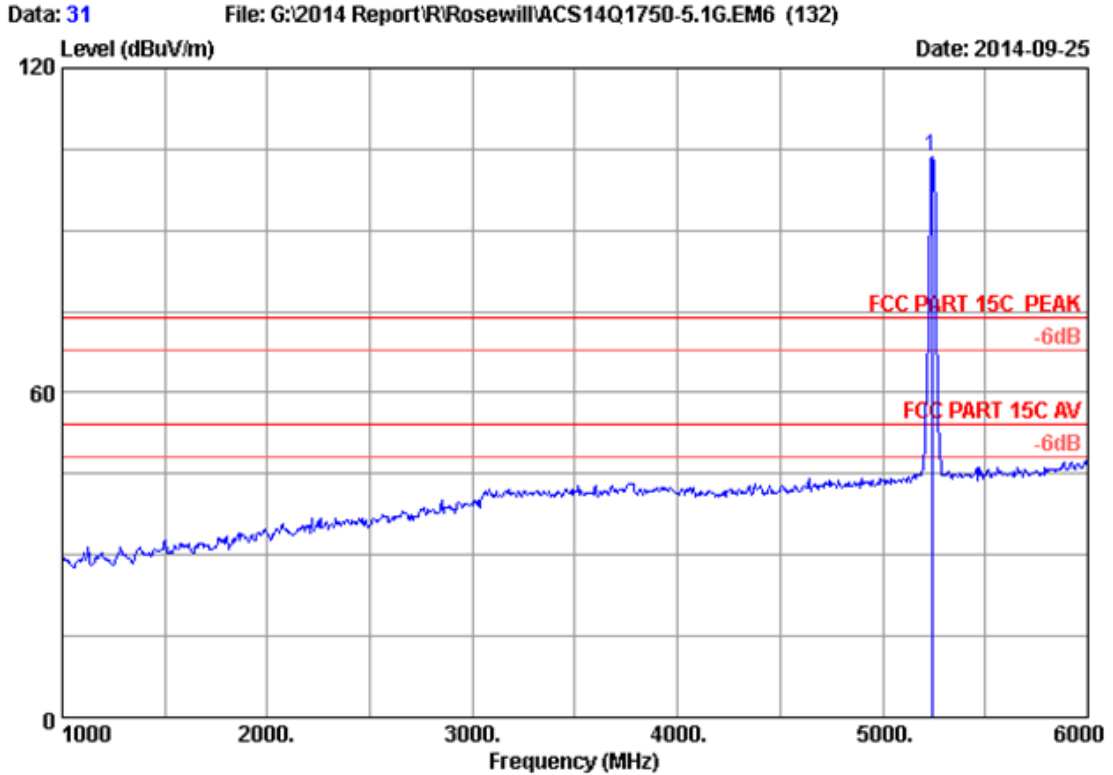

Site no. : 3m Chamber Data no. : 31
 Dis. / Ant. : 3m 2014 3115 (4580) Ant. pol. : VERTICAL
 Limit : FCC PART 15C PEAK
 Env. / Ins. : 24°C/56% Engineer : Leo-Li
 EUT : AC750 Wireless Dual Band Gigabit Router
 Power Rating : DC 12V From Adapter Input AC 120V/60Hz
 Test Mode : IEEE802.11nHT20 5240MHz Tx
 M/N : RNX-AC750RT

No.	Freq. (MHz)	Ant. Factor (dB/m)	Cable Loss (dB)	AMP factor (dB)	Reading (dBuV)	Emission Level (dBuV/m)	Limits (dBuV/m)	Margin (dB)	Remark
1	5240.000	33.58	9.02	35.70	96.73	103.63	74.00	-29.63	Peak

Remarks: 1. Emission Level= Antenna Factor + Cable Loss + Reading - Amp Factor
 2. The emission levels that are 20dB below the official limit are not reported.

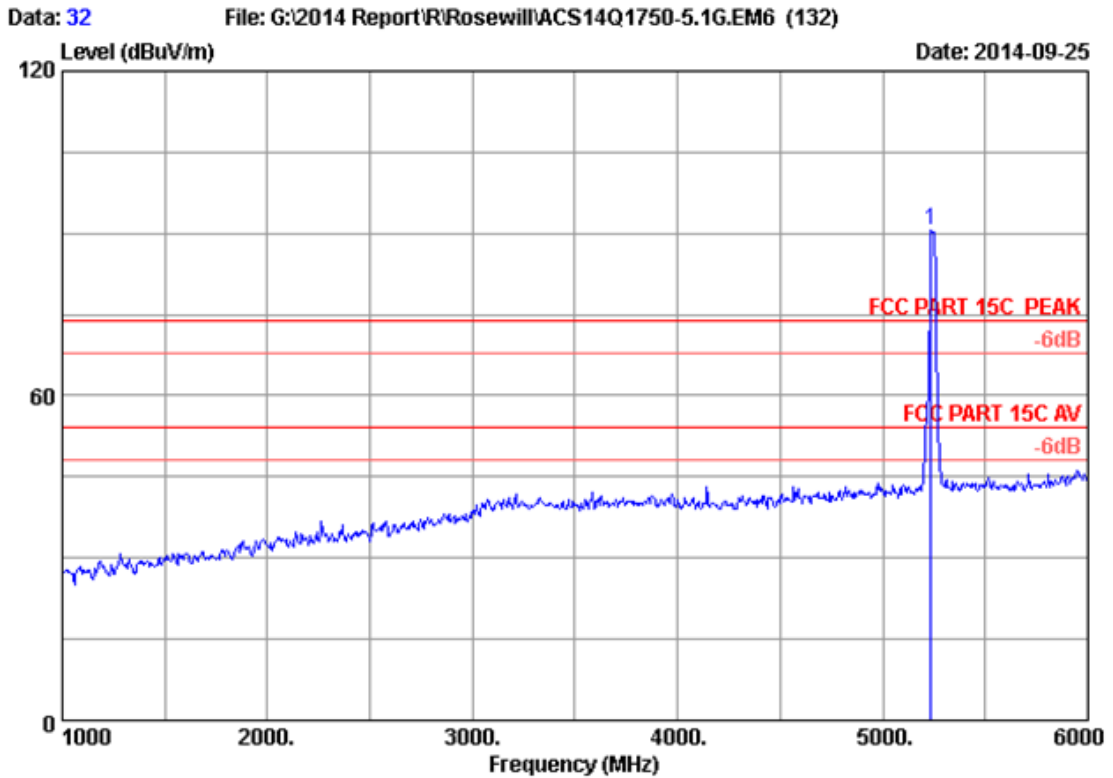

Site no. : 3m Chamber Data no. : 32
 Dis. / Ant. : 3m 2014 3115 (4580) Ant. pol. : HORIZONTAL
 Limit : FCC PART 15C PEAK
 Env. / Ins. : 24°C/56% Engineer : Leo-Li
 EUT : AC750 Wireless Dual Band Gigabit Router
 Power Rating : DC 12V From Adapter Input AC 120V/60Hz
 Test Mode : IEEE802.11nHT20 5240MHz Tx
 M/N : RNX-AC750RT

No.	Freq. (MHz)	Ant. Factor (dB/m)	Cable Loss (dB)	AMP factor (dB)	Reading (dBuV)	Emission Level (dBuV/m)	Limits (dBuV/m)	Margin (dB)	Remark
1	5235.000	33.58	9.01	35.70	83.62	90.51	74.00	-16.51	Peak

Remarks: 1. Emission Level= Antenna Factor + Cable Loss + Reading - Amp Factor
 2. The emission levels that are 20dB below the official limit are not reported.

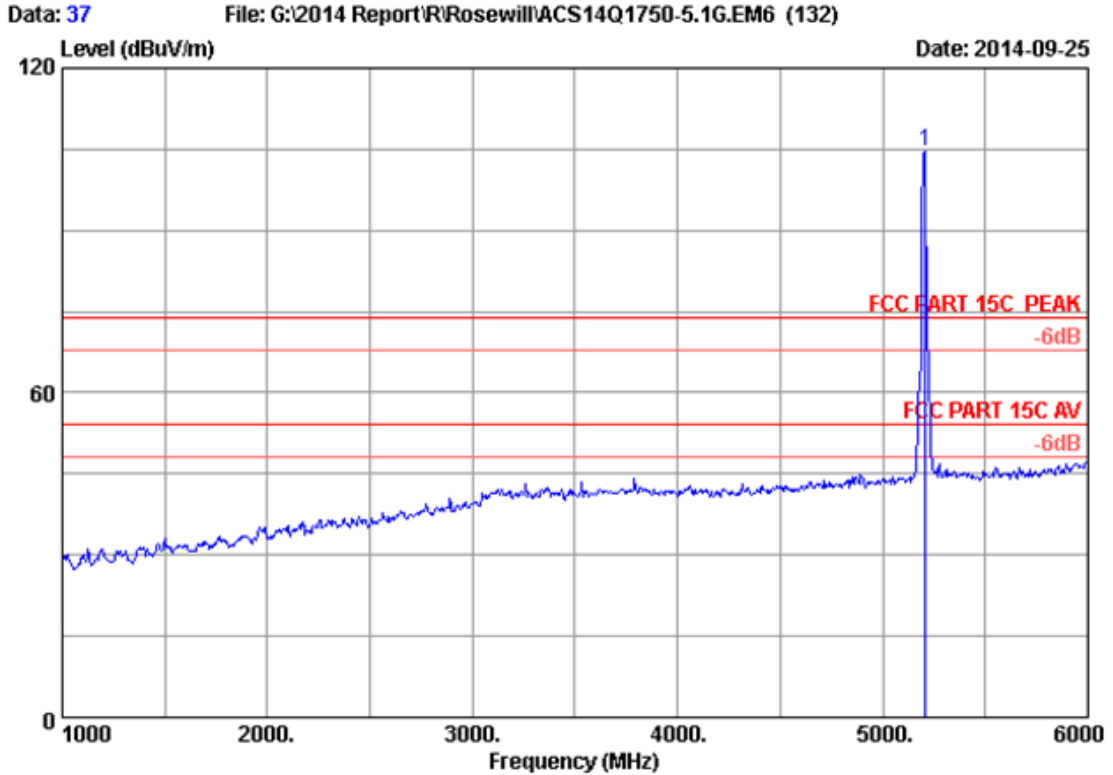

Site no. : 3m Chamber Data no. : 37
 Dis. / Ant. : 3m 2014 3115 (4580) Ant. pol. : VERTICAL
 Limit : FCC PART 15C PEAK
 Env. / Ins. : 24°C/56% Engineer : Leo-Li
 EUT : AC750 Wireless Dual Band Gigabit Router
 Power Rating : DC 12V From Adapter Input AC 120V/60Hz
 Test Mode : IEEE802.11nHT20 5200MHz Tx
 M/N : RNX-AC750RT

No.	Freq. (MHz)	Ant. Factor (dB/m)	Cable Loss (dB)	AMP factor (dB)	Reading (dBuV)	Emission Level (dBuV/m)	Limits (dBuV/m)	Margin (dB)	Remark
1	5210.000	33.54	8.98	35.70	97.87	104.69	74.00	-30.69	Peak

Remarks: 1. Emission Level= Antenna Factor + Cable Loss + Reading - Amp Factor
 2. The emission levels that are 20dB below the official limit are not reported.

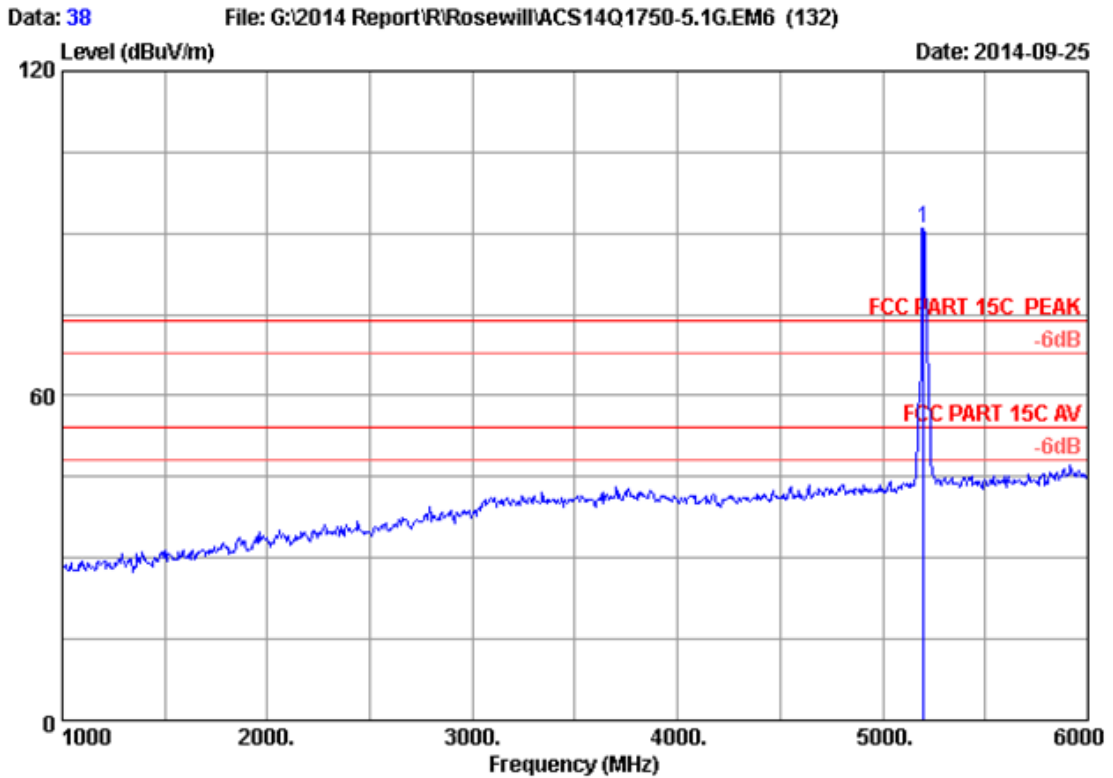

Site no. : 3m Chamber Data no. : 38
 Dis. / Ant. : 3m 2014 3115 (4580) Ant. pol. : HORIZONTAL
 Limit : FCC PART 15C PEAK
 Env. / Ins. : 24°C/56% Engineer : Leo-Li
 EUT : AC750 Wireless Dual Band Gigabit Router
 Power Rating : DC 12V From Adapter Input AC 120V/60Hz
 Test Mode : IEEE802.11nHT20 5200MHz Tx
 M/N : RNX-AC750RT

No.	Freq. (MHz)	Ant. Factor (dB/m)	Cable Loss (dB)	AMP factor (dB)	Reading (dBuV)	Emission Level (dBuV/m)	Limits (dBuV/m)	Margin (dB)	Remark
1	5200.000	33.52	8.97	35.70	84.30	91.09	74.00	-17.09	Peak

Remarks: 1. Emission Level= Antenna Factor + Cable Loss + Reading - Amp Factor
 2. The emission levels that are 20dB below the official limit are not reported.

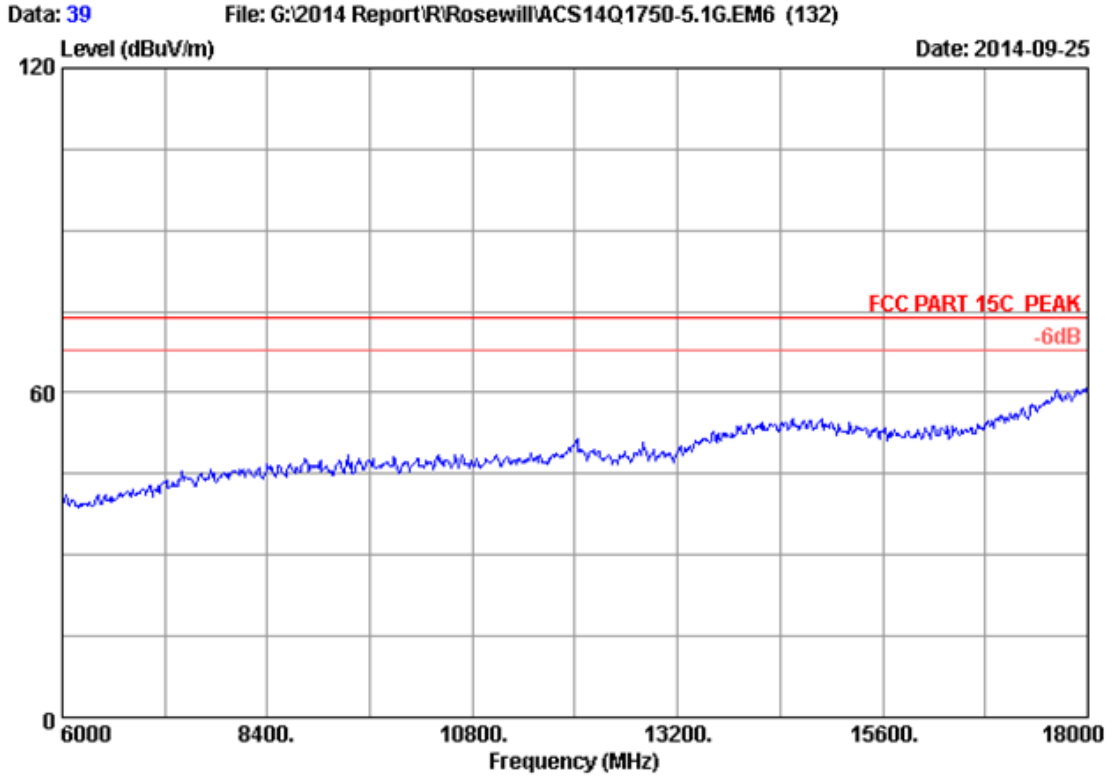

Site no. : 3m Chamber Data no. : 39
Dis. / Ant. : 3m 2014 3115 (4580) Ant. pol. : HORIZONTAL
Limit : FCC PART 15C PEAK
Env. / Ins. : 24*C/56% Engineer : Leo-Li
EUT : AC750 Wireless Dual Band Gigabit Router
Power Rating : DC 12V From Adapter Input AC 120V/60Hz
Test Mode : IEEE802.11nHT20 5200MHz Tx
M/N : RNX-AC750RT

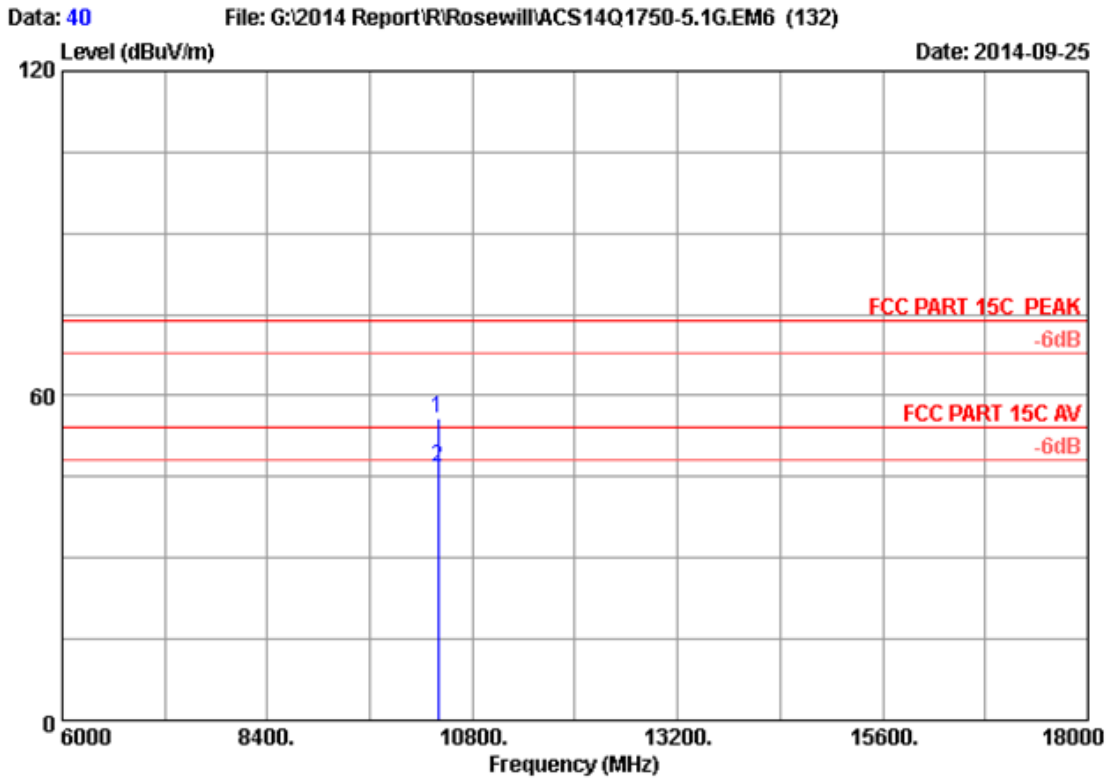

Site no. : 3m Chamber Data no. : 40
 Dis. / Ant. : 3m 2014 3115 (4580) Ant. pol. : HORIZONTAL
 Limit : FCC PART 15C PEAK
 Env. / Ins. : 24°C/56% Engineer : Leo-Li
 EUT : AC750 Wireless Dual Band Gigabit Router
 Power Rating : DC 12V From Adapter Input AC 120V/60Hz
 Test Mode : IEEE802.11nHT20 5200MHz Tx
 M/N : RNX-AC750RT

No.	Freq. (MHz)	Ant. Factor (dB/m)	Cable Loss (dB)	AMP factor (dB)	Reading (dBuV)	Emission Level (dBuV/m)	Limits (dBuV/m)	Margin (dB)	Remark
1	10400.000	38.16	12.66	35.44	40.35	55.73	74.00	18.27	Peak
2	10400.000	38.16	12.66	35.44	31.42	46.80	54.00	7.20	Average

Remarks: 1. Emission Level= Antenna Factor + Cable Loss + Reading - Amp Factor
 2. The emission levels that are 20dB below the official limit are not reported.

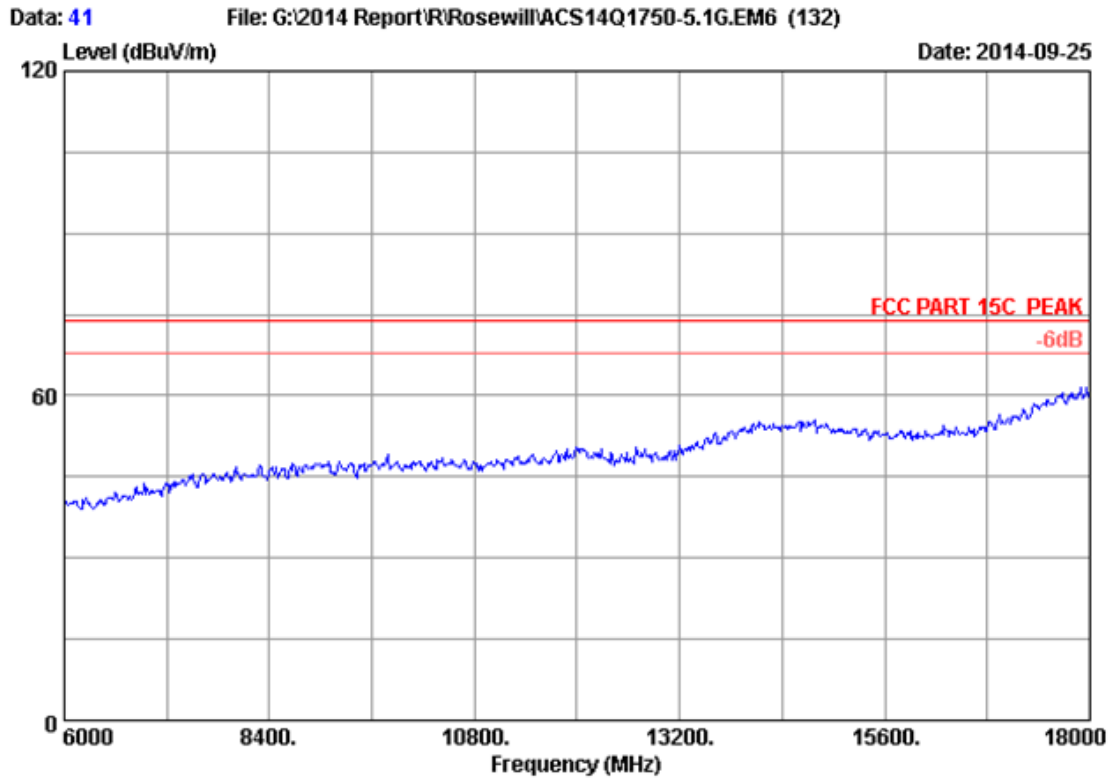

Site no. : 3m Chamber Data no. : 41
Dis. / Ant. : 3m 2014 3115 (4580) Ant. pol. : VERTICAL
Limit : FCC PART 15C PEAK
Env. / Ins. : 24°C/56% Engineer : Leo-Li
EUT : AC750 Wireless Dual Band Gigabit Router
Power Rating : DC 12V From Adapter Input AC 120V/60Hz
Test Mode : IEEE802.11nHT20 5200MHz Tx
M/N : RNX-AC750RT