



# FCC Part 15E Test Report

## FCC ID:W6R-AC2030PCE

Product Name:	AC2030 Wireless Dual Band PCI-Express Adapter
Trademark:	Rosewill
Model Name :	RNX-AC2030PCE
Prepared For :	Rosewill Inc.
Address :	17708 Rowland Street, City of Industry, CA 91748, USA
Prepared By :	Shenzhen BCTC Testing Co., Ltd.
Address :	BCTC Building & 1-2F, East of B Building, Pengzhou Industrial, Fuyuan 1st Road, Qiaotou Community, Fuyong Street, Bao'an District, Shenzhen, China
Test Date:	Jan. 02, 2019 to Jan. 29, 2019
Date of Report :	Jan. 29, 2019
Report No.:	BCTC-LH181203522-1E



### TEST RESULT CERTIFICATION

**Applicant's name** ..... : Rosewill Inc.  
**Address** ..... : 17708 Rowland Street, City of Industry, CA 91748, USA  
**Manufacturer's Name**..... : Rosewill Inc.  
**Address** ..... : 17708 Rowland Street, City of Industry, CA 91748, USA

**Product description**

**Product name** ..... : AC2030 Wireless Dual Band PCI-Express Adapter  
**Trademark** ..... : Rosewill  
**Model and/or type reference** : RNX-AC2030PCE  
**Standards** : FCC Part15 15.407  
 ANSI C63.10-2013  
 KDB 662911 D01 v02r01  
 KDB 789033 D02 v01r02

This device described above has been tested by BCTC, and the test results show that the equipment under test (EUT) is in compliance with the FCC requirements. And it is applicable only to the tested sample identified in the report.

This report shall not be reproduced except in full, without the written approval of BCTC, this document may be altered or revised by BCTC, personal only, and shall be noted in the revision of the document.

Prepared by(Engineer):      Leke Xie      Leke Xie

Reviewer(Supervisor):      Eric Yang      Eric Yang

Approved(Manager):      Carson Zhang      Carson Zhang





**Table of Contents**

	<b>Page</b>
<b>1 . SUMMARY OF TEST RESULTS</b>	<b>7</b>
1.1 TEST FACILITY	8
1.2 MEASUREMENT UNCERTAINTY	8
<b>2 . GENERAL INFORMATION</b>	<b>9</b>
2.1 GENERAL DESCRIPTION OF EUT	9
2.2 DESCRIPTION OF TEST MODES	11
2.3 BLOCK DIGRAM SHOWING THE CONFIGURATION OF SYSTEM TESTED	11
2.4 DESCRIPTION OF SUPPORT UNITS(CONDUCTED MODE)	12
2.5 EQUIPMENTS LIST FOR ALL TEST ITEMS	13
<b>3 . EMC EMISSION TEST</b>	<b>15</b>
3.1 CONDUCTED EMISSION MEASUREMENT	15
3.1.1 POWER LINE CONDUCTED EMISSION LIMITS	15
3.1.2 TEST PROCEDURE	16
3.1.3 DEVIATION FROM TEST STANDARD	16
3.1.4 TEST SETUP	16
3.1.5 EUT OPERATING CONDITIONS	16
3.1.6 TEST RESULTS	17
3.2 RADIATED EMISSION MEASUREMENT	21
3.2.1 APPLICABLE STANDARD	21
3.2.2 CONFORMANCE LIMIT	21
3.2.3 MEASURING INSTRUMENTS	21
3.2.4 TEST CONFIGURATION	22
3.2.5 TEST PROCEDURE	23
3.2.6 TEST RESULTS (9KHZ – 30 MHZ)	24
3.2.7 TEST RESULTS (30MHZ – 1GHZ)	25
3.2.8 TEST RESULTS (1GHZ-40GHZ)	29
<b>4 . POWER SPECTRAL DENSITY TEST</b>	<b>30</b>
4.1 APPLIED PROCEDURES / LIMIT	30
4.2 TEST PROCEDURE	31
4.3 DEVIATION FROM STANDARD	31
4.4 TEST SETUP	31
4.5 EUT OPERATION CONDITIONS	31
4.6 TEST RESULTS	33
<b>5 . 6DB &amp; 99% EMISSION BANDWIDTH</b>	<b>36</b>



**Table of Contents**

	<b>Page</b>
5.1 APPLIED PROCEDURES / LIMIT	36
5.2 TEST PROCEDURE	36
5.3 EUT OPERATION CONDITIONS	37
5.4 TEST RESULTS	38
<b>6 . MAXIMUM CONDUCTED OUTPUT POWER</b>	<b>43</b>
6.1 PPLIED PROCEDURES / LIMIT	43
6.2 TEST PROCEDURE	43
6.3 DEVIATION FROM STANDARD	43
6.4 TEST SETUP	43
6.5 EUT OPERATION CONDITIONS	43
6.6 TEST RESULTS	44
<b>7 . OUT OF BAND EMISSIONS</b>	<b>45</b>
7.1 APPLICABLE STANDARD	45
7.2 TEST PROCEDURE	45
7.3 DEVIATION FROM STANDARD	45
7.4 TEST SETUP	45
7.5 EUT OPERATION CONDITIONS	45
7.6 TEST RESULTS	46
<b>8. SPURIOUS RF CONDUCTED EMISSIONS</b>	<b>49</b>
8.1 CONFORMANCE LIMIT	49
8.2 MEASURING INSTRUMENTS	49
8.3 TEST SETUP	49
8.4 TEST PROCEDURE	49
8.5 TEST RESULTS	49
<b>9. FREQUENCY STABILITY MEASUREMENT</b>	<b>55</b>
9.1 LIMIT	55
9.2 TEST PROCEDURES	55
9.3 TEST SETUP LAYOUT	55
9.4 EUT OPERATION DURING TEST	55
9.5 TEST RESULTS	56
<b>10. ANTENNA REQUIREMENT</b>	<b>60</b>
10.1 STANDARD REQUIREMENT	60
10.2 EUT ANTENNA	60
<b>11. EUT TEST PHOTO</b>	<b>61</b>



## Table of Contents

	Page
12. EUT PHOTO	65



**Revision History**

Report No.	Version	Description	Issued Date
BCTC-LH181203522-1E	Rev.01	Initial issue of report	Jan. 29, 2019



### 1. SUMMARY OF TEST RESULTS

Test procedures according to the technical standards:

FCC Part15 (15.407) , Subpart E			
Standard Section	Test Item	Judgment	Remark
15.209(a), 15.407 (b)(1) 15.407 (b)(6)	Spurious Radiated Emissions	PASS	
15.407 (a)(1) 15.1049	6 dB and 99% Emission Bandwidth	PASS	
15.407 (a)(1) 15.407 (a)(3)	Maximum Conducted Output Power	PASS	
2.1051, 15.407(b)(1)	Band Edge	PASS	
15.407 (a)(1)	Power Spectral Density	PASS	
2.1051, 15.407(b)	Spurious Emissions at Antenna Terminals	PASS	
15.203	Antenna Requirement	PASS	

NOTE:

(1) "N/A" denotes test is not applicable in this Test Report



**1.1 TEST FACILITY**

Shenzhen BCTC Testing Co., Ltd.

Add. : BCTC Building & 1-2F, East of B Building, Pengzhou Industrial, Fuyuan 1st Road, Qiaotou Community, Fuyong Street, Bao'an District, Shenzhen, China

FCC Test Firm Registration Number: 712850

IC Registered No.: 23583

**1.2 MEASUREMENT UNCERTAINTY**

The reported uncertainty of measurement  $y \pm U$  , where expended uncertainty  $U$  is based on a standard uncertainty multiplied by a coverage factor of  $k=2$  , providing a level of confidence of approximately **95 %**.

No.	Item	Uncertainty
1	3m chamber Radiated spurious emission(30MHz-1GHz)	U=4.3dB
2	3m chamber Radiated spurious emission(1GHz-18GHz)	U=4.5dB
3	3m chamber Radiated spurious emission(18GHz-40GHz)	U=3.34dB
4	Conducted Adjacent channel power	U=1.38dB
5	Conducted output power uncertainty Above 1G	U=1.576dB
6	Conducted output power uncertainty below 1G	U=1.28dB
7	humidity uncertainty	U=5.3%
8	Temperature uncertainty	U=0.59℃
9	Radiated disturbance(30MHz-1000MHz)	U=4.8dB
10	Radiated disturbance(1GHz-6GHz)	U=4.9dB
11	Radiated disturbance(1GHz-18GHz)	U=5.0dB





2. GENERAL INFORMATION

2.1 GENERAL DESCRIPTION OF EUT

Equipment	AC2030 Wireless Dual Band PCI-Express Adapter	
Trade Name	Rosewill	
Model Name	RNX-AC2030PCE	
Model Difference	N/A	
Product Description	IEEE 802.11 WLAN Mode Supported	<input checked="" type="checkbox"/> 802.11a/n (20MHz channel bandwidth) <input checked="" type="checkbox"/> 802.11n (40MHz channel bandwidth) <input checked="" type="checkbox"/> 802.11ac(80MHz channel bandwidth)
	Data Rate	802.11a: 6,9,12,18,24,36,48,54Mbps; 802.11n(HT20/HT40):MCS0-MCS15; 802.11ac(VHT80):NSS1, MCS0-MCS9
	Modulation	OFDM with BPSK/QPSK/16QAM/64QAM/256QAM for 802.11a/n/ac;
	Operating Frequency Range	<input checked="" type="checkbox"/> 5745-5825 MHz for 802.11a/n(HT20); 5755-5795 MHz for 802.11a/n(HT40); 5775MHz for 802.11 ac80;
	Number of Channels	<input checked="" type="checkbox"/> 5 channels for 802.11a/n20 in the 5745-5825MHz band ; 2 channels for 802.11 n40 in the 5755-5795MHz band ; 1 channels for 802.11 ac80 in the 5775MHz band ;
	Based on the application, features, or specification exhibited in User's Manual, the EUT is considered as an ITE/Computing Device. More details of EUT technical specification, please refer to the User's Manual.	
Channel List	Please refer to the Note 2.	
Power	DC 5V form PC	
hardware version	N/A	
Software version	N/A	
Serial number	N/A	
Connecting I/O Port(s)	Please refer to the User's Manual	

Note:

1. For a more detailed features description, please refer to the manufacturer's specifications or the User's Manual.



2 Frequency and Channel list for 802.11a/n(20 MHz) band IV (5745-5825MHz):

802.11a/n ( 20 MHz) Carrier Frequency Channel							
Channel	Frequency (MHz)	Channel	Frequency (MHz)	Channel	Frequency (MHz)	Channel	Frequency (MHz)
149	5745	153	5765	157	5785	161	5805
165	5825	-	-	-	-	-	-

802.11n40MHz Carrier Frequency Channel					
Channel	Frequency (MHz)	Channel	Frequency (MHz)	Channel	Frequency (MHz)
151	5755	159	5795	-	-

802.11ac80MHz Carrier Frequency Channel	
Channel	Frequency (MHz)
155	5775

Tx Antenna

Antenna	Antenna Type	Antenna Gain(dBi)
Antenna 1(long)	External antenna	2
Antenna 2(Box)	External antenna	2

The Antenna 1 support for 5.8G, the Antenna 2 support for 5.8G, 5.8G transmitting do not support MIMO.

**2.2 DESCRIPTION OF TEST MODES**

Pretest Mode	Description
Mode 1	802.11a / n 20 CH36/ CH40/ CH 48 802.11a /n 20 CH149/ CH157/ CH 165
Mode 2	802.11n 40 CH38/ CH 46 802.11n 40 CH 151 / CH 159
Mode 3	802.11 ac80 CH 42/CH 155
Mode 4	802.11a / n 20 CH36/ CH40/ CH 48 802.11a /n 20 CH149/ CH157/ CH 165
Mode 5	Link Mode

Conducted Emission	
Final Test Mode	Description
Mode 5	Link Mode

For Radiated Emission	
Final Test Mode	Description
Mode 1	802.11a / n 20 CH36/ CH40/ CH 48 802.11a /n 20 CH149/ CH157/ CH 165
Mode 2	802.11n 40 CH38/ CH 46 802.11n 40 CH 151 / CH 159
Mode 3	802.11 ac80 CH 42/CH 155
Mode 4	802.11a / n 20 CH36/ CH40/ CH 48 802.11a /n 20 CH149/ CH157/ CH 165

Note:

(1) The measurements are performed at all Bit Rate of Transmitter, the worst data was reported.

**2.3 BLOCK DIGRAM SHOWING THE CONFIGURATION OF SYSTEM TESTED**

Conducted Emission Test

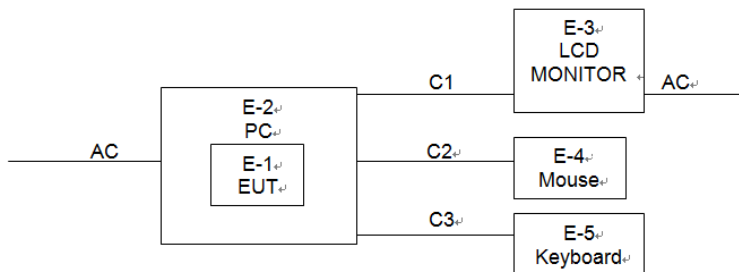

Radiated Spurious Emission

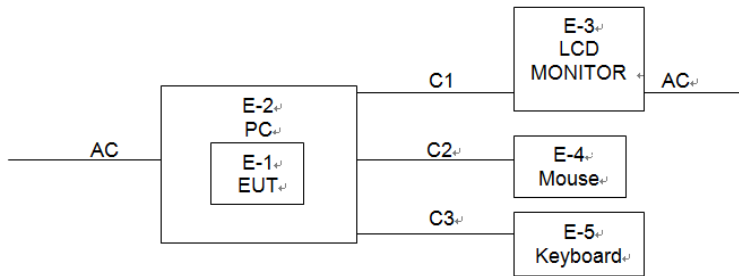

**2.4 DESCRIPTION OF SUPPORT UNITS(CONDUCTED MODE)**

The EUT has been tested as an independent unit together with other necessary accessories or support units. The following support units or accessories were used to form a representative test configuration during the tests.

Item	Equipment	Mfr/Brand	Model/Type No.	Series No.	Note
E-1	AC2030 Wireless Dual Band PCI-Express Adapter	N/A	RNX-AC2030PCE	N/A	EUT
E-2	PC	N/A	T4900C	N/A	Auxiliary
E-3	LCD MONITOR	N/A	P72P	N/A	Auxiliary
E-4	Mouse	N/A	LW300	N/A	Auxiliary
E-5	Keyboard	N/A	KB4721	N/A	Auxiliary

Item	Shielded Type	Ferrite Core	Length	Note
C-1	NO	NO	1M	HDMI cable shielded
C-2	NO	NO	1M	USB cable unshielded
C-3	NO	NO	1M	USB cable unshielded

Note:

- (1) The support equipment was authorized by Declaration of Confirmation.
- (2) For detachable type I/O cable should be specified the length in cm in 『Length』 column.



## 2.5 EQUIPMENTS LIST FOR ALL TEST ITEMS

### Radiation Test equipment

Item	Equipment	Manufacturer	Type No.	Serial No.	Last calibration	Calibrated until
1	Spectrum Analyzer (9kHz-26.5GHz)	Agilent	E4407B	MY45109572	2018.06.20	2019.06.20
2	Test Receiver (9kHz-7GHz)	R&S	ESR7	101154	2018.06.20	2019.06.20
3	Bilog Antenna (30MHz-3GHz)	SCHWARZBECK	VULB9163	VULB9163-942	2018.06.23	2019.06.23
4	Horn Antenna (1GHz-18GHz)	SCHWARZBECK	BBHA9120D	1541	2018.06.23	2021.06.22
5	Horn Antenna (18GHz-40GHz)	SCHWARZBECK	BBHA9170	822	2018.08.06	2019.08.06
6	Amplifier (9KHz-6GHz)	SCHWARZBECK	BBV9744	9744-0037	2018.06.20	2019.06.20
7	Amplifier (0.5GHz-18GHz)	SCHWARZBECK	BBV9718	9718-309	2018.06.20	2019.06.20
8	Amplifier (18GHz-40GHz)	MITEQ	TTA1840-35-HG	2034381	2018.08.06	2019.08.06
9	Loop Antenna (9KHz-30MHz)	SCHWARZBECK	FMZB1519B	014	2018.06.23	2019.06.23
10	RF cables1 (9kHz-30MHz)	Huber+Suhnar	9kHz-30MHz	B1702988-0008	2018.02.12	2019.02.12
11	RF cables2 (30MHz-1GHz)	Huber+Suhnar	30MHz-1GHz	1486150	2018.03.27	2019.03.27
12	RF cables3 (1GHz-40GHz)	Huber+Suhnar	1GHz-40GHz	1607106	2018.06.19	2019.06.19
13	Power Metter	Keysight	E4419	\	2018.04.15	2019.04.15
14	Power Sensor (AV)	Keysight	E9 300A	\	2018.04.15	2019.04.15
15	Signal Analyzer 20kHz-26.5GHz	KEYSIGHT	N9020A	MY49100060	2018.08.14	2019.08.13
16	Test Receiver 9kHz-40GHz	R&S	FSP40	100550	2018.06.13	2019.06.12
17	D.C. Power Supply	LongWei	TPR-6405D	\	\	\
18	Software	Frad	EZ-EMC	FA-03A2 RE	\	\



Conduction Test equipment

Item	Equipment	Manufacturer	Type No.	Serial No.	Last calibration	Calibrated until
1	Test Receiver	R&S	ESR3	102075	2018.06.20	2019.06.20
2	LISN	SCHWARZBEC K	NSLK8127	8127739	2018.06.19	2019.06.19
3	LISN	R&S	ENV216	101375	2018.06.20	2019.06.20
4	RF cables	Huber+Suhnar	9kHz-30MHz	B1702988-00 08	2018.02.12	2019.02.12
5	Software	Frad	EZ-EMC	EMC-CON 3A1	\	\



### 3. EMC EMISSION TEST

#### 3.1 CONDUCTED EMISSION MEASUREMENT

##### 3.1.1 POWER LINE CONDUCTED EMISSION Limits (Frequency Range 150KHz-30MHz)

FREQUENCY (MHz)	Class B (dBuV)		Standard
	Quasi-peak	Average	
0.15 -0.5	66 - 56 *	56 - 46 *	CISPR
0.50 -5.0	56.00	46.00	CISPR
5.0 -30.0	60.00	50.00	CISPR

0.15 -0.5	66 - 56 *	56 - 46 *	FCC/ RSS-247
0.50 -5.0	56.00	46.00	FCC/ RSS-247
5.0 -30.0	60.00	50.00	FCC/ RSS-247

Note:

- (1) The tighter limit applies at the band edges.
- (2) The limit of " \* " marked band means the limitation decreases linearly with the logarithm of the frequency in the range.

The following table is the setting of the receiver

Receiver Parameters	Setting
Attenuation	10 dB
Start Frequency	0.15 MHz
Stop Frequency	30 MHz
IF Bandwidth	9 kHz

### 3.1.2 TEST PROCEDURE

- The EUT was placed 0.8 meters from the horizontal ground plane with EUT being connected to the power mains through a line impedance stabilization network (LISN). All other support equipments powered from additional LISN(s). The LISN provide 50 Ohm/ 50uH of coupling impedance for the measuring instrument.
- Interconnecting cables that hang closer than 40 cm to the ground plane shall be folded back and forth in the center forming a bundle 30 to 40 cm long.
- I/O cables that are not connected to a peripheral shall be bundled in the center. The end of the cable may be terminated, if required, using the correct terminating impedance. The overall length shall not exceed 1 m.
- LISN at least 80 cm from nearest part of EUT chassis.
- For the actual test configuration, please refer to the related Item –EUT Test Photos.

### 3.1.3 DEVIATION FROM TEST STANDARD

No deviation

### 3.1.4 TEST SETUP

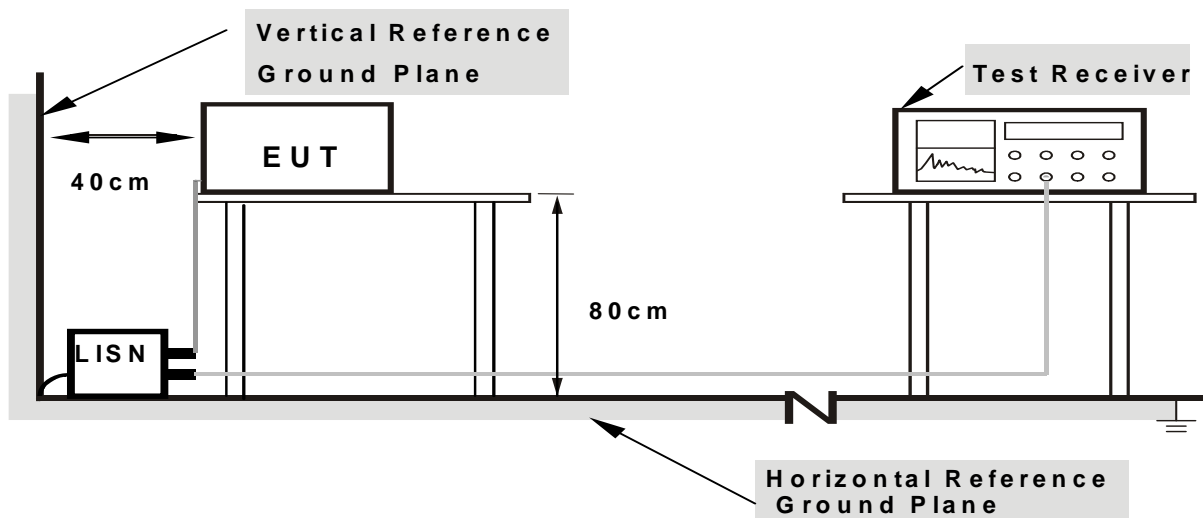

**Note: 1. Support units were connected to second LISN.**

**2. Both of LISNs (AMN) are 80 cm from EUT and at least 80 cm from other units and other metal planes**

### 3.1.5 EUT OPERATING CONDITIONS

The EUT was configured for testing in a typical fashion (as a customer would normally use it). The EUT has been programmed to continuously transmit during test. This operating condition was tested and used to collect the included data.

We pretest AC 120V and AC 230V, the worst voltage was AC 120V and the data recording in the report.





**3.1.6 TEST RESULTS**

Temperature :	26 °C	Relative Humidity :	54%
Pressure :	101kPa	Phase :	L
Test Voltage :	DC 5V form PC AC 120V/60Hz(ANT1)	Test Mode :	Mode 5

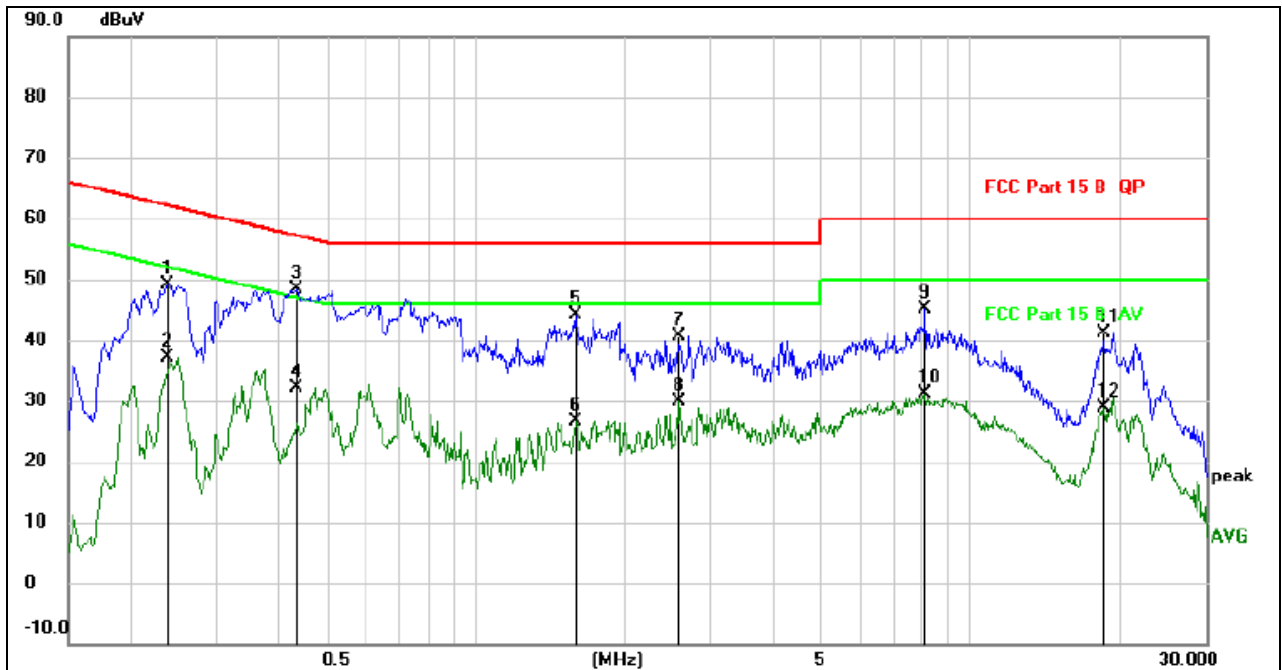

Remark:

1. All readings are Quasi-Peak and Average values.
2. Factor = Insertion Loss + Cable Loss.

No.	Mk.	Freq. MHz	Reading Level dBuV	Correct Factor	Measure- ment dBuV	Limit dBuV	Over dB	Detector	Comment
1		0.2378	39.72	9.51	49.23	62.17	-12.94	QP	
2		0.2378	27.64	9.51	37.15	52.17	-15.02	AVG	
3	*	0.4349	38.97	9.53	48.50	57.16	-8.66	QP	
4		0.4349	22.70	9.53	32.23	47.16	-14.93	AVG	
5		1.5933	34.50	9.58	44.08	56.00	-11.92	QP	
6		1.5933	17.13	9.58	26.71	46.00	-19.29	AVG	
7		2.5807	30.91	9.63	40.54	56.00	-15.46	QP	
8		2.5807	20.36	9.63	29.99	46.00	-16.01	AVG	
9		8.0624	35.37	9.71	45.08	60.00	-14.92	QP	
10		8.0624	21.51	9.71	31.22	50.00	-18.78	AVG	
11		18.6219	31.38	9.76	41.14	60.00	-18.86	QP	
12		18.6219	19.18	9.76	28.94	50.00	-21.06	AVG	



Temperature :	26 °C	Relative Humidity :	54%
Pressure :	101kPa	Phase :	N
Test Voltage :	DC 5V form PC AC 120V/60Hz (ANT1)	Test Mode :	Mode 5

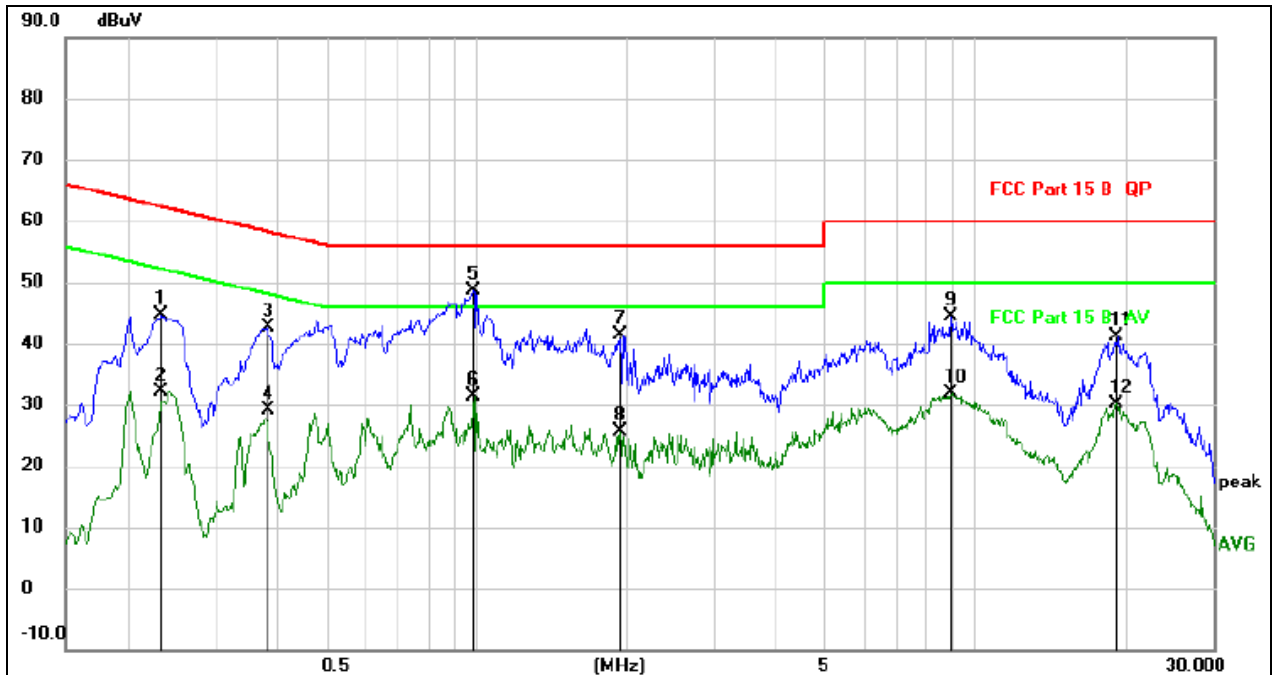

Remark:

1. All readings are Quasi-Peak and Average values.
2. Factor = Insertion Loss + Cable Loss.

No.	Mk.	Freq. MHz	Reading Level dBuV	Correct Factor	Measure- ment dBuV	Limit dBuV	Over dB	Detector	Comment
1		0.2328	35.07	9.50	44.57	62.35	-17.78	QP	
2		0.2328	22.60	9.50	32.10	52.35	-20.25	AVG	
3		0.3810	33.02	9.52	42.54	58.26	-15.72	QP	
4		0.3810	19.67	9.52	29.19	48.26	-19.07	AVG	
5	*	0.9838	39.15	9.57	48.72	56.00	-7.28	QP	
6		0.9838	21.87	9.57	31.44	46.00	-14.56	AVG	
7		1.9386	31.79	9.59	41.38	56.00	-14.62	QP	
8		1.9386	15.94	9.59	25.53	46.00	-20.47	AVG	
9		8.9161	34.63	9.70	44.33	60.00	-15.67	QP	
10		8.9161	22.09	9.70	31.79	50.00	-18.21	AVG	
11		19.1219	31.30	9.77	41.07	60.00	-18.93	QP	
12		19.1219	20.28	9.77	30.05	50.00	-19.95	AVG	



Temperature :	26 °C	Relative Humidity :	54%
Pressure :	101kPa	Phase :	L
Test Voltage :	DC 5V form PC AC 120V/60Hz(ANT2)	Test Mode :	Mode 5

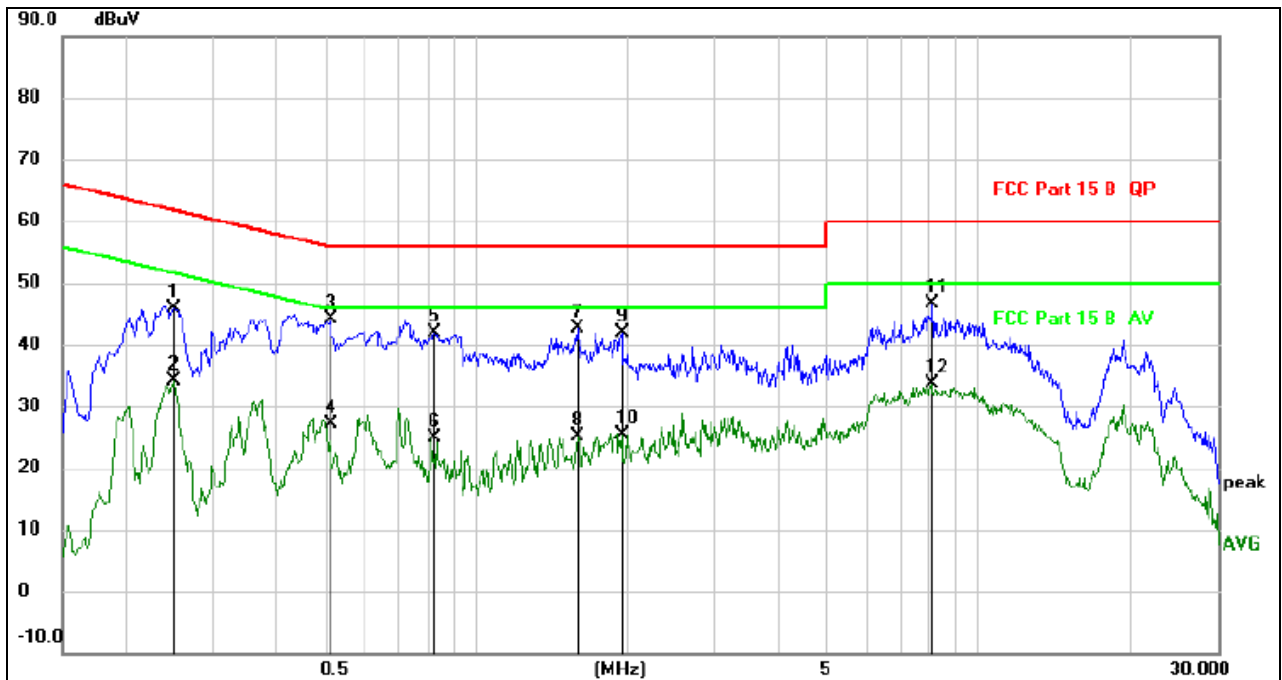

Remark:

1. All readings are Quasi-Peak and Average values.
2. Factor = Insertion Loss + Cable Loss.

No.	Mk.	Freq.	Reading Level	Correct Factor	Measurement	Limit	Over	Detector	Comment
		MHz	dBuV		dBuV	dBuV	dB		
1		0.2494	36.34	9.52	45.86	61.78	-15.92	QP	
2		0.2494	24.63	9.52	34.15	51.78	-17.63	AVG	
3	*	0.5128	34.45	9.64	44.09	56.00	-11.91	QP	
4		0.5128	17.43	9.64	27.07	46.00	-18.93	AVG	
5		0.8257	32.17	9.62	41.79	56.00	-14.21	QP	
6		0.8257	15.22	9.62	24.84	46.00	-21.16	AVG	
7		1.5931	33.00	9.58	42.58	56.00	-13.42	QP	
8		1.5931	15.63	9.58	25.21	46.00	-20.79	AVG	
9		1.9489	32.24	9.59	41.83	56.00	-14.17	QP	
10		1.9489	15.88	9.59	25.47	46.00	-20.53	AVG	
11		8.1051	36.87	9.71	46.58	60.00	-13.42	QP	
12		8.1051	24.01	9.71	33.72	50.00	-16.28	AVG	



Temperature :	26 °C	Relative Humidity :	54%
Pressure :	101kPa	Phase :	N
Test Voltage :	DC 5V form PC AC 120V/60Hz(ANT2)	Test Mode :	Mode 5

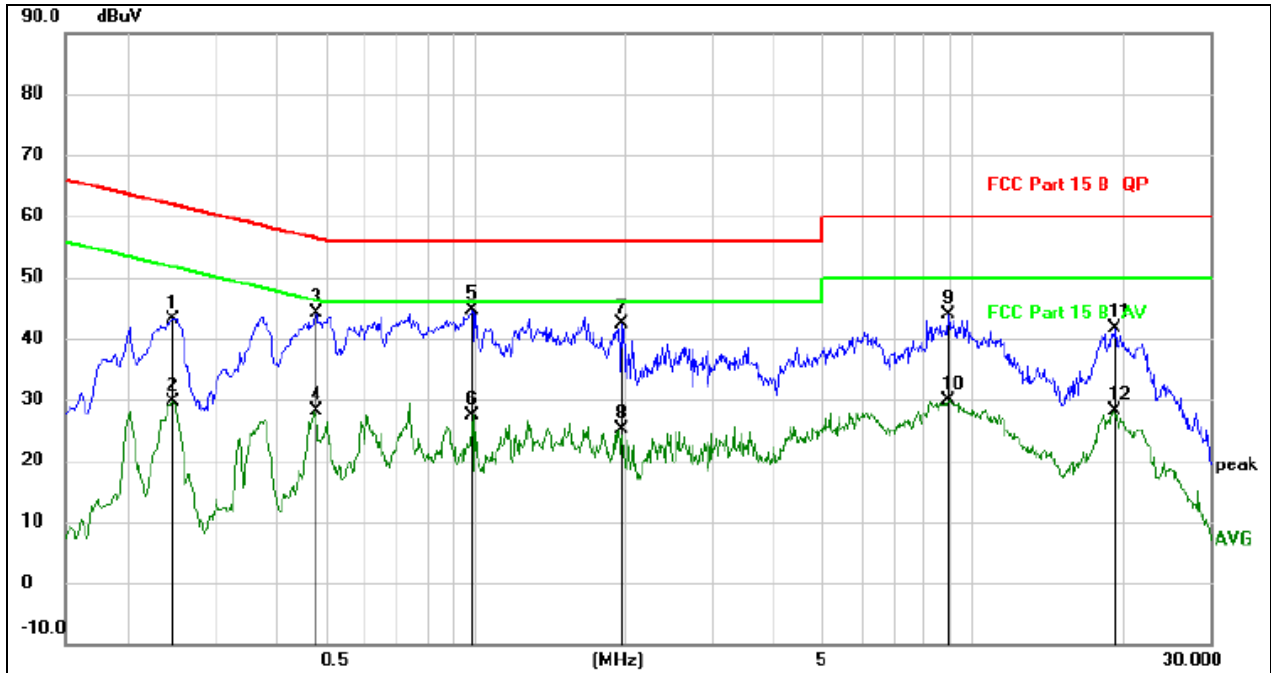

Remark:

1. All readings are Quasi-Peak and Average values.
2. Factor = Insertion Loss + Cable Loss.

No.	Mk.	Freq. MHz	Reading Level dBuV	Correct Factor	Measure- ment dBuV	Limit dBuV	Over dB	Detector	Comment
1		0.2467	33.70	9.52	43.22	61.87	-18.65	QP	
2		0.2467	20.06	9.52	29.58	51.87	-22.29	AVG	
3		0.4786	34.57	9.57	44.14	56.36	-12.22	QP	
4		0.4786	18.62	9.57	28.19	46.36	-18.17	AVG	
5	*	0.9838	35.15	9.57	44.72	56.00	-11.28	QP	
6		0.9838	17.87	9.57	27.44	46.00	-18.56	AVG	
7		1.9697	32.79	9.59	42.38	56.00	-13.62	QP	
8		1.9697	15.44	9.59	25.03	46.00	-20.97	AVG	
9		8.9161	34.13	9.70	43.83	60.00	-16.17	QP	
10		8.9161	20.09	9.70	29.79	50.00	-20.21	AVG	
11		19.3257	31.79	9.78	41.57	60.00	-18.43	QP	
12		19.3257	18.27	9.78	28.05	50.00	-21.95	AVG	



### 3.2 RADIATED EMISSION MEASUREMENT

#### 3.2.1 APPLICABLE STANDARD

According to FCC Part 15.407(d) and 15.209

#### 3.2.2 CONFORMANCE LIMIT

According to FCC Part 15.407(b)(7): radiated emissions which fall in the restricted bands, as defined in §15.205(a), must also comply with the radiated emission limits specified in §15.209(a) (see §15.205(c)).  
According to FCC Part 15.205, Restricted bands

MHz	MHz	MHz	GHz
0.090-0.110	16.42-16.423	399.9-410	4.5-5.15
10.495-0.505	16.69475-16.69525	608-614	5.35-5.46
2.1735-2.1905	16.80425-16.80475	960-1240	7.25-7.75
4.125-4.128	25.5-25.67	1300-1427	8.025-8.5
4.17725-4.17775	37.5-38.25	1435-1626.5	9.0-9.2
4.20725-4.20775	73-74.6	1645.5-1646.5	9.3-9.5
6.215-6.218	74.8-75.2	1660-1710	10.6-12.7
6.26775-6.26825	123-138	2200-2300	14.47-14.5
8.291-8.294	149.9-150.05	2310-2390	15.35-16.2
8.362-8.366	156.52475-156.52525	2483.5-2500	17.7-21.4
8.37625-8.38675	156.7-156.9	2690-2900	22.01-23.12
8.41425-8.41475	162.0125-167.17	3260-3267	23.6-24.0
12.29-12.293	167.72-173.2	3332-3339	31.2-31.8
12.51975-12.52025	240-285	3345.8-3358	36.43-36.5
12.57675-12.57725	322-335.4	3600-4400	(2)
13.36-13.41			

20dBc in any 100 kHz bandwidth outside the operating frequency band. In case the emission fall within the restricted band specified on 15.205(a), then the 15.209(a) limit in the table below has to be followed.

Restricted Frequency(MHz)	Field Strength (µV/m)	Field Strength (dBµV/m)	Measurement Distance
0.009~0.490	2400/F(KHz)	20 log (uV/m)	300
0.490~1.705	2400/F(KHz)	20 log (uV/m)	30
1.705~30.0	30	29.5	30
30-88	100	40	3
88-216	150	43.5	3
216-960	200	46	3
Above 960	500	54	3

#### Limits of Radiated Emission Measurement(Above 1000MHz)

Frequency(MHz)	Class B (dBuV/m) (at 3M)	
	PEAK	AVERAGE
Above 1000	74	54

- Remark : 1. Emission level in dBuV/m=20 log (uV/m)  
2. Measurement was performed at an antenna to the closed point of EUT distance of meters.  
3. Distance extrapolation factor =40log(Specific distance/ test distance)( dB);  
Limit line=Specific limits(dBuV) + distance extrapolation factor.

#### 3.2.3 MEASURING INSTRUMENTS

The Measuring equipment is listed in the section 6.3 of this test report.

### 3.2.4 TEST CONFIGURATION

(a) For radiated emissions below 30MHz

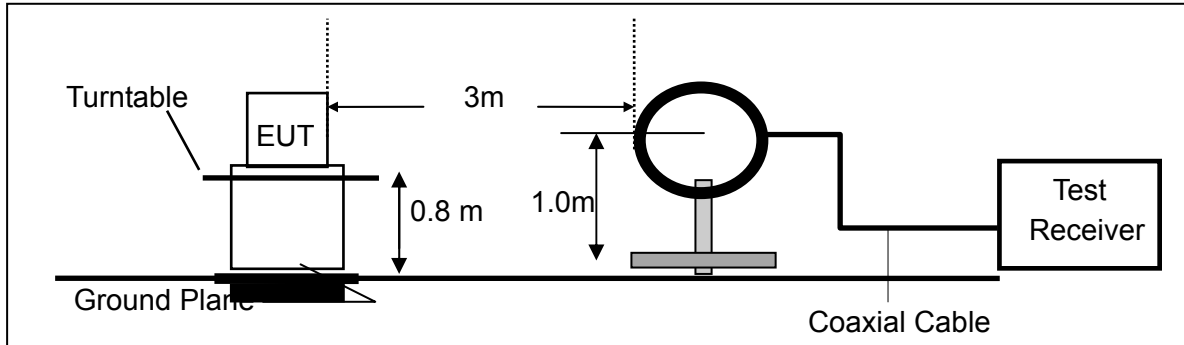

(b) For radiated emissions from 30MHz to 1000MHz

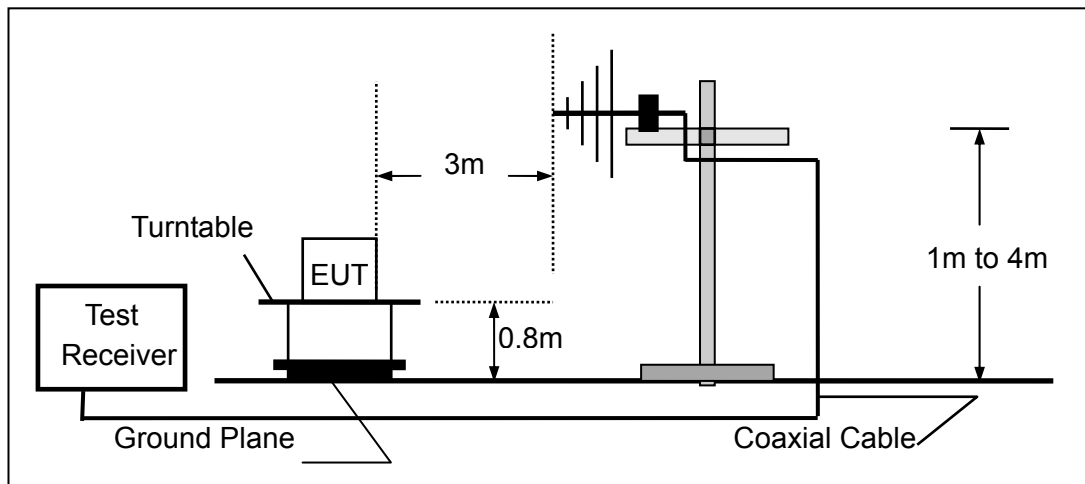

(c) For radiated emissions above 1000MHz

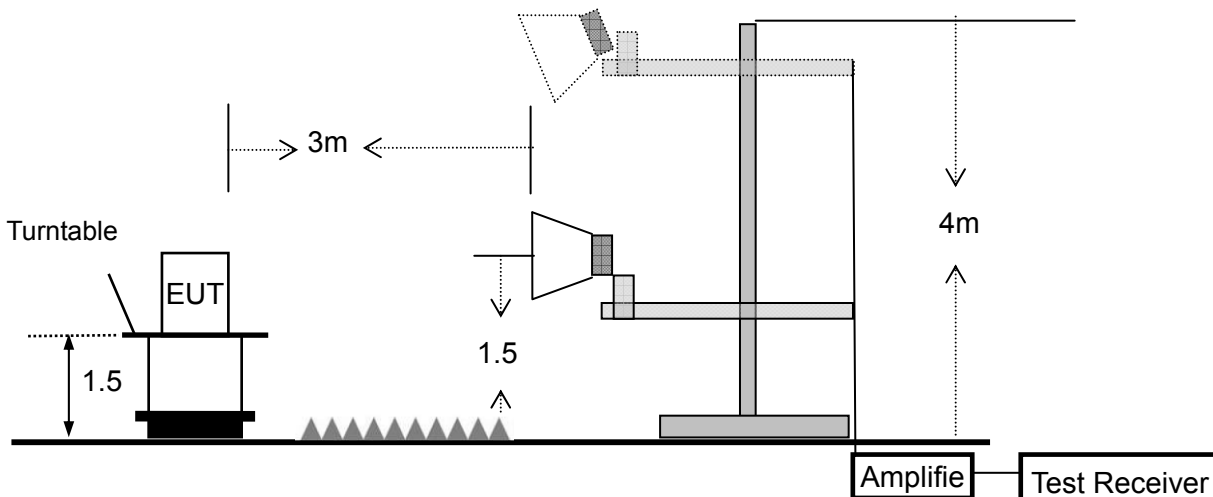



### 3.2.5 TEST PROCEDURE

The test site semi-anechoic chamber has met the requirement of NSA tolerance 4 dB according to the standards: ANSI C63.10-2013. The test distance is 3m. The setup is according to the requirements in Section 13.1.4.1 of ANSI C63.10-2013 and CAN/CSA-CEI/IEC CISPR 22.

This test is required for any spurious emission that falls in a Restricted Band, as defined in Section 15.205. It must be performed with the highest gain of each type of antenna proposed for use with the EUT.

Use the following spectrum analyzer settings:

Spectrum Parameter	Setting
Attenuation	Auto
Start Frequency	1000 MHz
Stop Frequency	10th carrier harmonic
RB / VB (emission in restricted band)	1 MHz / 1 MHz for Peak, 1 MHz / 10Hz for Average

Receiver Parameter	Setting
Attenuation	Auto
Start ~ Stop Frequency	9kHz~150kHz / RB 200Hz for QP
Start ~ Stop Frequency	150kHz~30MHz / RB 9kHz for QP
Start ~ Stop Frequency	30MHz~1000MHz / RB 120kHz for QP

- The measuring distance of at 3 m shall be used for measurements at frequency up to 1GHz. For frequencies above 1GHz, any suitable measuring distance may be used.
- The EUT was placed on the top of a rotating table 0.8 m for below 1GHz and 1.5m for above 1GHz the ground at a 3 meter. The table was rotated 360 degrees to determine the position of the highest radiation.
- The height of the equipment or of the substitution antenna shall be 0.8 m for below 1GHz and 1.5m for above 1GHz; the height of the test antenna shall vary between 1 m to 4 m. Both horizontal and vertical polarizations of the antenna are set to make the measurement.
- The initial step in collecting conducted emission data is a spectrum analyzer peak detector mode pre-scanning the measurement frequency range. Significant peaks are then marked and then Quasi Peak detector mode re-measured.
- If the Peak Mode measured value compliance with and lower than Quasi Peak Mode Limit, the EUT shall be deemed to meet QP Limits and then no additional QP Mode measurement performed.
- For the actual test configuration, please refer to the related Item –EUT Test Photos.

Note:

Both horizontal and vertical antenna polarities were tested and performed pretest to three orthogonal axis. The worst case emissions were reported

During the radiated emission test, the Spectrum Analyzer was set with the following configurations:

Frequency Band (MHz)	Function	Resolution bandwidth	Video Bandwidth
30 to 1000	QP	120 kHz	300 kHz
Above 1000	Peak	1 MHz	1 MHz
	Average	1 MHz	10 Hz

Note: for the frequency ranges below 30 MHz, a narrower RBW is used for these ranges but the measured value should add a RBW correction factor (RBWCF) where  $RBWCF [dB] = 10 * \lg(100 [kHz] / \text{narrower RBW [kHz]})$ . , the narrower RBW is 1 kHz and RBWCF is 20 dB for the frequency 9 kHz to 150 kHz, and the narrower RBW is 10 kHz and RBWCF is 10 dB for the frequency 150 kHz to 30 MHz.



**3.2.6 TEST RESULTS (9KHZ – 30 MHZ)**

Temperature:	26℃	Relative Humidity:	54%
Pressure:	101kPa	Test Voltage :	DC 5V form PC AC 12 0V/60Hz
Test Mode :	Mode 5	Polarization :	--

Freq.	Reading	Limit	Margin	State
(MHz)	(dBuV/m)	(dBuV/m)	(dB)	P/F
--	--	--	--	N/A
--	--	--	--	N/A

The amplitude of spurious emissions which are attenuated by more than 20dB below the permissible value has no need to be reported.

Distance extrapolation factor = 40 log (specific distance/test distance)(dB);

Limit line = specific limits(dBuV) + distance extrapolation factor.





**3.2.7 TEST RESULTS (30MHZ – 1GHZ)**

Temperature :	26°C	Relative Humidity :	54%
Pressure :	101 kPa	Polarization :	Horizontal
Test Voltage :	DC 5V form PC AC 120V/60Hz		
Test Mode :	Mode 5(ANT 1) - 802.11a		

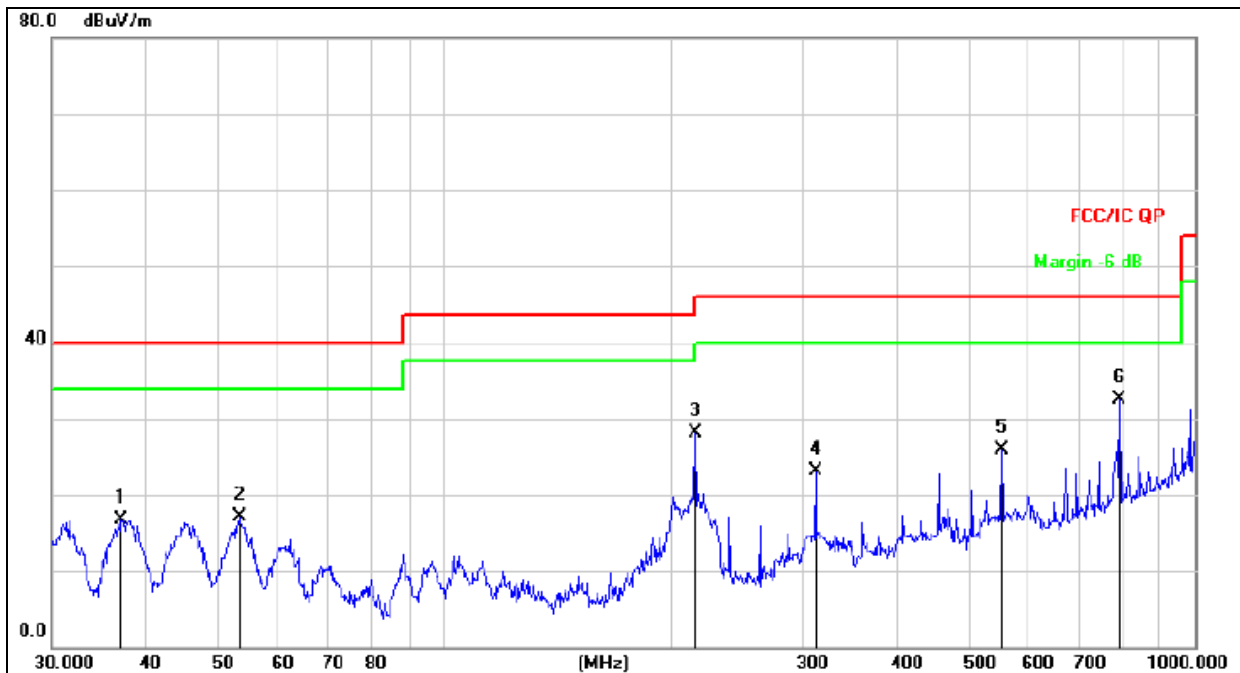

Remark:  
Factor = Antenna Factor + Cable Loss – Pre-amplifier.

No.	Mk.	Freq. MHz	Reading Level dBuV	Correct Factor dB	Measure- ment dBuV/m	Limit dB/m	Over dB	Detector
1		37.1550	32.58	-15.94	16.64	40.00	-23.36	QP
2		53.3179	32.23	-15.20	17.03	40.00	-22.97	QP
3		216.0240	44.02	-15.93	28.09	46.00	-17.91	QP
4		312.1792	36.36	-13.27	23.09	46.00	-22.91	QP
5		552.8831	33.55	-7.61	25.94	46.00	-20.06	QP
6	*	793.3960	36.20	-3.73	32.47	46.00	-13.53	QP



Temperature :	26°C	Relative Humidity :	54%
Pressure :	101kPa	Polarization :	Vertical
Test Voltage :	DC 5V form PC AC 120V/60Hz		
Test Mode :	Mode 5(ANT 1) - 802.11a		

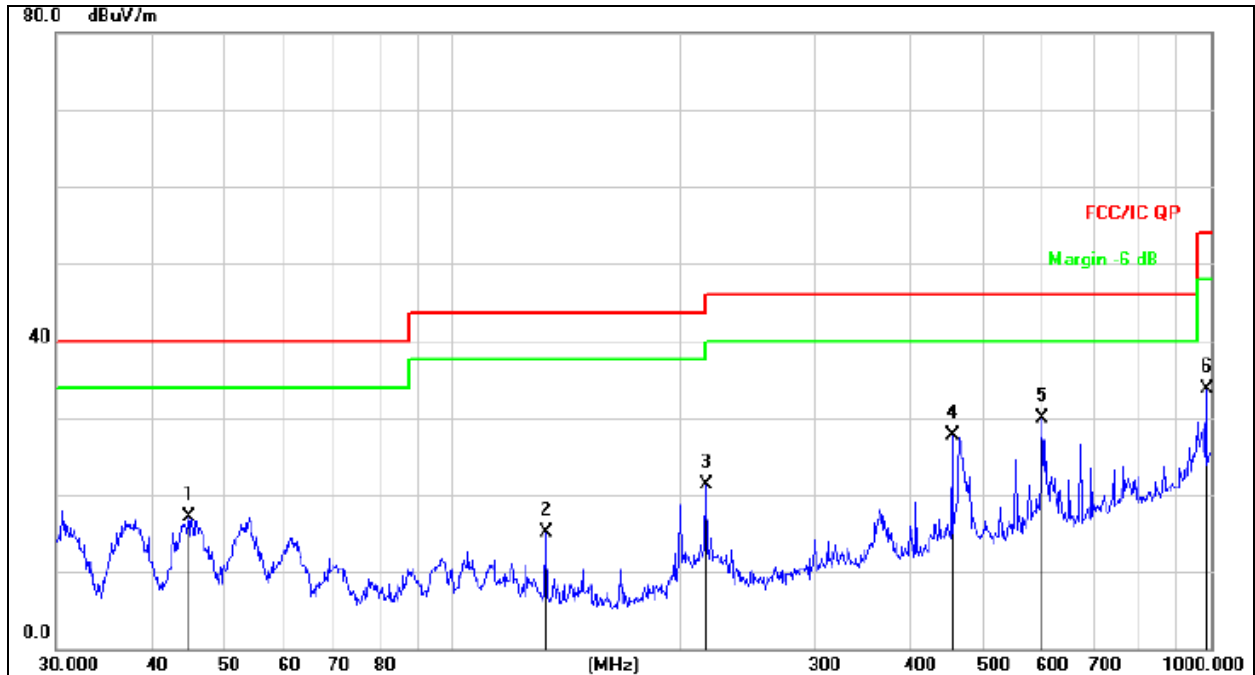

Remark:  
Factor = Antenna Factor + Cable Loss – Pre-amplifier.

No.	Mk.	Freq. MHz	Reading Level dBuV	Correct Factor dB	Measure- ment dBuV/m	Limit dB/m	Over dB	Detector
1		44.9006	32.34	-15.14	17.20	40.00	-22.80	QP
2		132.6850	33.54	-18.38	15.16	43.50	-28.34	QP
3		216.0240	37.26	-15.93	21.33	46.00	-24.67	QP
4		455.9057	37.57	-9.85	27.72	46.00	-18.28	QP
5	*	599.3211	36.44	-6.54	29.90	46.00	-16.10	QP
6		986.0717	34.56	-0.89	33.67	54.00	-20.33	QP

All the operating modes have test, and the results for worst-case reported.



Temperature :	26°C	Relative Humidity :	54%
Pressure :	101 kPa	Polarization :	Horizontal
Test Voltage :	DC 5V form PC AC 120V/60Hz		
Test Mode :	Mode 5(ANT 2) - 802.11a		

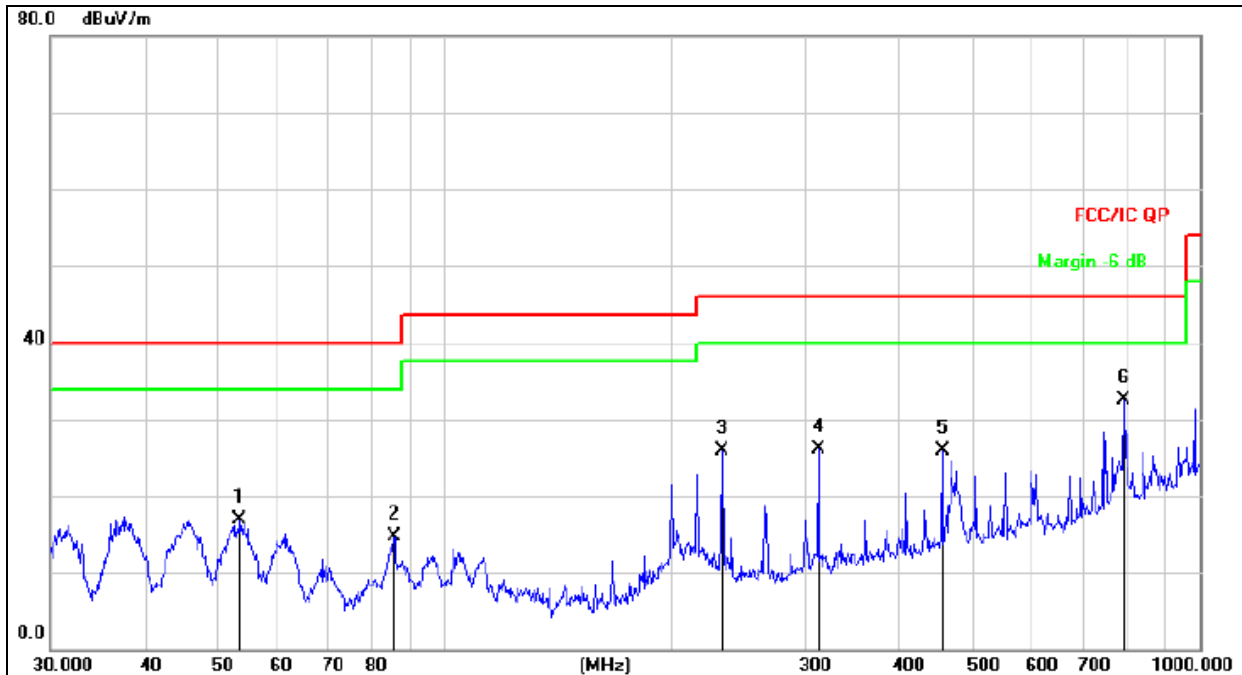

Remark:  
Factor = Antenna Factor + Cable Loss – Pre-amplifier.

No.	Mk.	Freq. MHz	Reading Level dBuV	Correct Factor dB	Measure- ment dBuV/m	Limit dB/m	Over dB	Detector
1		53.5052	32.16	-15.22	16.94	40.00	-23.06	QP
2		85.5977	33.84	-19.12	14.72	40.00	-25.28	QP
3		232.5318	41.41	-15.55	25.86	46.00	-20.14	QP
4		312.1794	39.34	-13.27	26.07	46.00	-19.93	QP
5		455.9057	35.71	-9.85	25.86	46.00	-20.14	QP
6	*	793.3960	36.20	-3.73	32.47	46.00	-13.53	QP



Temperature :	26°C	Relative Humidity :	54%
Pressure :	101kPa	Polarization :	Vertical
Test Voltage :	DC 5V form PC AC 120V/60Hz		
Test Mode :	Mode 5 (ANT 2) - 802.11a		

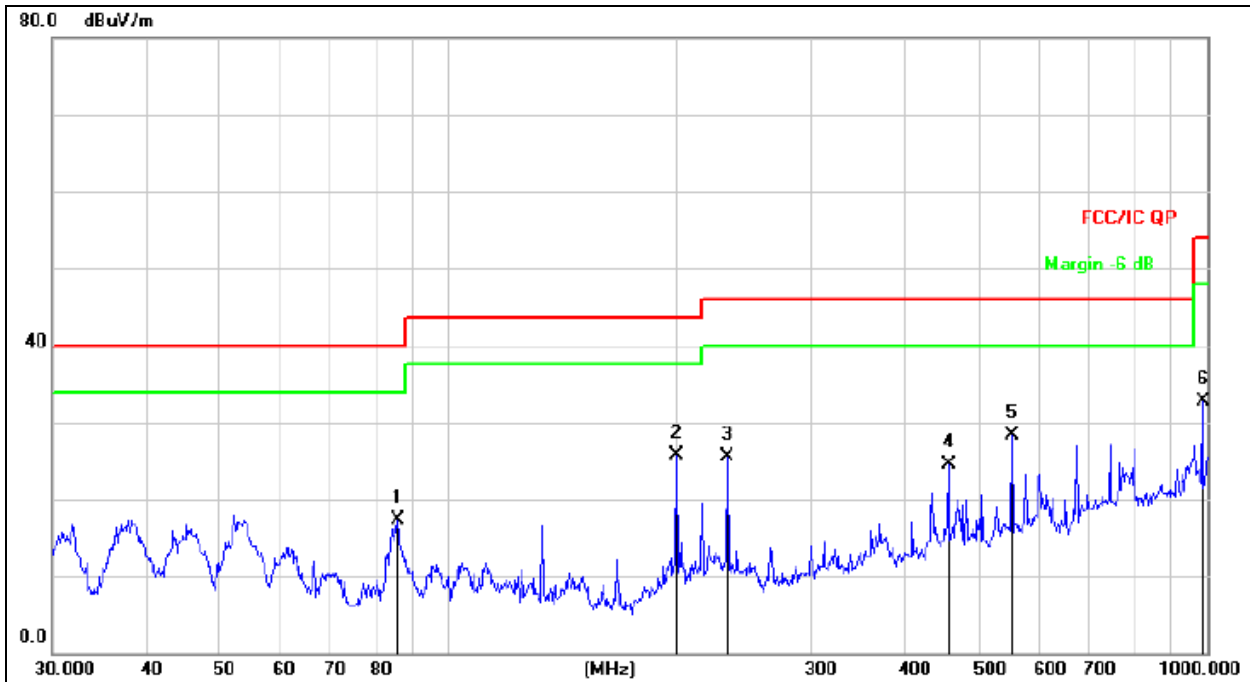

Remark:  
Factor = Antenna Factor + Cable Loss – Pre-amplifier.

No.	Mk.	Freq. MHz	Reading Level dBuV	Correct Factor dB	Measure- ment dBuV/m	Limit dB/m	Over dB	Detector
1		85.5977	36.37	-19.12	17.25	40.00	-22.75	QP
2	*	199.9856	42.07	-16.30	25.77	43.50	-17.73	QP
3		232.5318	41.14	-15.55	25.59	46.00	-20.41	QP
4		455.9057	34.27	-9.85	24.42	46.00	-21.58	QP
5		552.8831	35.84	-7.61	28.23	46.00	-17.77	QP
6		986.0717	33.57	-0.89	32.68	54.00	-21.32	QP

All the operating modes have test, and the results for worst-case reported.



**3.2.8 TEST RESULTS (1GHz-40GHz)**

Temperature :	26°C	Relative Humidity :	54%
Pressure :	1010 hPa	Test Voltage :	DC 5V
Test Mode :	TX (5.8G) -- 802.11a ANT1		

Polar	Frequency	Meter Reading	Cable loss	Antenna Factor	Preamp Factor	Emission Level	Limits	Margin	Detector Type
(H/V)	(MHz)	(dBuV)	(dB)	dB/m	(dB)	(dBuV/m)	(dBuV/m)	(dB)	
<b>Low Channel (5745 MHz)-Above 1G</b>									
Vertical	4679.195	59.92	5.94	35.40	44.00	57.26	74.00	-16.74	Pk
Vertical	4679.195	39.61	5.94	35.40	44.00	36.95	54.00	-17.05	AV
Vertical	11490.364	59.58	8.46	39.75	44.50	63.29	74.00	-10.71	Pk
Vertical	11490.364	42.13	8.46	39.75	44.50	45.84	54.00	-8.16	AV
Vertical	17235.101	55.52	10.12	38.80	44.10	60.34	74.00	-13.66	Pk
Vertical	17235.101	38.64	10.12	38.80	42.70	44.86	54.00	-9.14	AV
Horizontal	4679.332	57.93	5.94	35.18	44.00	55.05	74.00	-18.95	Pk
Horizontal	4679.332	44.55	5.94	35.18	44.00	41.67	54.00	-12.33	AV
Horizontal	11490.164	56.68	8.46	38.71	44.50	59.35	74.00	-14.65	Pk
Horizontal	11490.164	40.12	8.46	38.71	44.50	42.79	54.00	-11.21	AV
Horizontal	17235.196	58.63	10.12	38.38	44.10	63.03	74.00	-10.97	Pk
Horizontal	17235.196	42.28	10.12	38.38	44.10	46.68	54.00	-7.32	AV
<b>middle Channel (5785 MHz)-Above 1G</b>									
Vertical	4592.228	59.81	6.48	36.35	44.05	58.59	74.00	-15.41	Pk
Vertical	4592.228	43.34	6.48	36.35	44.05	42.12	54.00	-11.88	AV
Vertical	11570.203	61.15	8.47	37.88	44.51	62.99	74.00	-11.01	Pk
Vertical	11570.203	43.21	8.47	37.88	44.51	45.05	54.00	-8.95	AV
Vertical	17355.147	59.58	10.12	38.8	44.10	64.4	74.00	-9.6	Pk
Vertical	17355.147	42.32	10.12	38.8	42.70	48.54	54.00	-5.46	AV
Horizontal	4592.526	58.64	6.48	36.37	44.05	57.44	74.00	-16.56	Pk
Horizontal	4592.526	43.37	6.48	36.37	44.05	42.17	54.00	-11.83	AV
Horizontal	11570.123	60.01	8.47	38.64	44.50	62.62	74.00	-11.38	Pk
Horizontal	11570.123	42.22	8.47	38.64	44.50	44.83	54.00	-9.17	AV
Horizontal	17355.269	57.51	10.12	38.38	44.10	61.91	74.00	-12.09	Pk
Horizontal	17355.269	42.23	10.12	38.38	44.10	46.63	54.00	-7.37	AV
<b>High Channel (5825 MHz)-Above 1G</b>									
Vertical	6039.199	57.65	7.10	37.24	43.50	58.49	74.00	-15.51	Pk
Vertical	6039.199	42.21	7.10	37.24	43.50	43.05	54.00	-10.95	AV
Vertical	11652.562	58.73	8.46	37.68	44.50	60.37	74.00	-13.63	Pk
Vertical	11652.562	41.14	8.46	37.68	44.50	42.78	54.00	-11.22	AV
Vertical	17473.128	58.55	10.12	38.8	44.10	63.37	74.00	-10.63	Pk
Vertical	17473.128	40.35	10.12	38.8	42.70	46.57	54.00	-7.43	AV
Horizontal	6039.232	59.96	7.10	37.24	43.50	60.8	74.00	-13.2	Pk
Horizontal	6039.232	43.38	7.10	37.24	43.50	44.22	54.00	-9.78	AV
Horizontal	11652.319	52.26	8.46	38.57	44.50	54.79	74.00	-19.21	Pk
Horizontal	11652.319	40.14	8.46	38.57	44.50	42.67	54.00	-11.33	AV
Horizontal	17474.062	57.21	10.12	38.38	44.10	61.61	74.00	-12.39	Pk
Horizontal	17474.062	40.36	10.12	38.38	44.10	44.76	54.00	-9.24	AV

Note:"802.11a(5G)" ANT1 mode is the worst mode. PK value is lower than the Average value limit, So average didn't record.

The 26.5-40G amplitude of spurious emissions that are attenuated by more than 20dB below the permissible value has no need to be reported.

Emission level (dBuV/m) = 20 log Emission level (uV/m).

Corrected Reading: Antenna Factor + Cable Loss + Read Level - Preamp Factor = Level.



## 4. POWER SPECTRAL DENSITY TEST

### 4.1 APPLIED PROCEDURES / LIMIT

#### According to FCC §15.407(3)

Power limits:

(1) For the band 5.15-5.25 GHz.

(i) For an outdoor access point operating in the band 5.15-5.25 GHz, the maximum power spectral density shall not exceed 17 dBm in any 1 megahertz band. If transmitting antennas of directional gain greater than 6 dBi are used, both the maximum conducted output power and the maximum power spectral density shall be reduced by the amount in dB that the directional gain of the antenna exceeds 6 dBi. The maximum e.i.r.p. at any elevation angle above 30 degrees as measured from the horizon must not exceed 125 mW (21 dBm).

(ii) For an indoor access point operating in the band 5.15-5.25 GHz, the maximum power spectral density shall not exceed 17 dBm in any 1 megahertz band. If transmitting antennas of directional gain greater than 6 dBi are used, both the maximum conducted output power and the maximum power spectral density shall be reduced by the amount in dB that the directional gain of the antenna exceeds 6 dBi.

(iii) For fixed point-to-point access points operating in the band 5.15-5.25 GHz, the maximum power spectral density shall not exceed 17 dBm in any 1 megahertz band. Fixed point-to-point U-NII devices may employ antennas with directional gain up to 23 dBi without any corresponding reduction in the maximum conducted output power or maximum power spectral density. For fixed point-to-point transmitters that employ a directional antenna gain greater than 23 dBi, a 1 dB reduction in maximum conducted output power and maximum power spectral density is required for each 1 dB of antenna gain in excess of 23 dBi. Fixed, point-to-point operations exclude the use of point-to-multipoint systems, omnidirectional applications, and multiple collocated transmitters transmitting the same information. The operator of the U-NII device, or if the equipment is professionally installed, the installer, is responsible for ensuring that systems employing high gain directional antennas are used exclusively for fixed, point-to-point operations.

(iv) For client devices in the 5.15-5.25 GHz band, the maximum power spectral density shall not exceed 11 dBm in any 1 megahertz band. If transmitting antennas of directional gain greater than 6 dBi are used, both the maximum conducted output power and the maximum power spectral density shall be reduced by the amount in dB that the directional gain of the antenna exceeds 6 dBi.

(2) For the 5.25-5.35 GHz and 5.47-5.725 GHz bands, the maximum conducted output power over the frequency bands of operation shall not exceed the lesser of 250 mW or  $11 \text{ dBm} + 10 \log B$ , where B is the 26 dB emission bandwidth in megahertz. In addition, the maximum power spectral density shall not exceed 11 dBm in any 1 megahertz band. If transmitting antennas of directional gain greater than 6 dBi are used, both the maximum conducted output power and the maximum power spectral density shall be reduced by the amount in dB that the directional gain of the antenna exceeds 6 dBi.

(3) For the band 5.725-5.85 GHz, the maximum conducted output power over the frequency band of operation shall not exceed 1 W. In addition, the maximum power spectral density shall not exceed 30 dBm in any 500-kHz band. If transmitting antennas of directional gain greater than 6 dBi are used, both the maximum conducted output power and the maximum power spectral density shall be reduced by the amount in dB that the directional gain of the antenna exceeds 6 dBi. However, fixed point-to-point U-NII devices operating in this band may employ transmitting antennas with directional gain greater than 6 dBi without any corresponding reduction in transmitter conducted power. Fixed, point-to-point operations exclude the use of point-to-multipoint systems, omnidirectional applications,



and multiple collocated transmitters transmitting the same information. The operator of the U-NII device, or if the equipment is professionally installed, the installer, is responsible for ensuring that systems employing high gain directional antennas are used exclusively for fixed, point-to-point operations.

## 4.2 TEST PROCEDURE

For devices operating in the bands 5.15-5.25 GHz, 5.25-5.35 GHz, and 5.47-5.725 GHz, the above procedures make use of 1 MHz RBW to satisfy directly the 1 MHz reference bandwidth specified in § 15.407(a)(5). For devices operating in the band 5.725-5.85 GHz, the rules specify a measurement bandwidth of 500 kHz. Many spectrum analyzers do not have 500 kHz RBW, thus a narrower RBW may need to be used. The rules permit the use of a RBWs less than 1 MHz, or 500 kHz, “provided that the measured power is integrated over the full reference bandwidth” to show the total power over the specified measurement bandwidth (i.e., 1 MHz, or 500 kHz). If measurements are performed using a reduced resolution bandwidth (< 1 MHz, or < 500 kHz) and integrated over 1 MHz, or 500 KHz bandwidth, the following adjustments to the procedures apply:

- a) Set  $RBW \geq 1/T$ , where T is defined in section II.B.I.a).
- b) Set  $VBW \geq 3 RBW$ .
- c) If measurement bandwidth of Maximum PSD is specified in 500 kHz, add  $10\log(500\text{kHz}/RBW)$  to the measured result, whereas RBW (< 500 KHz) is the reduced resolution bandwidth of the spectrum analyzer set during measurement.
- d) If measurement bandwidth of Maximum PSD is specified in 1 MHz, add  $10\log(1\text{MHz}/RBW)$  to the measured result, whereas RBW (< 1 MHz) is the reduced resolution bandwidth of spectrum analyzer set during measurement.
- e) Care must be taken to ensure that the measurements are performed during a period of continuous transmission or are corrected upward for duty cycle.

Note: As a practical matter, it is recommended to use reduced RBW of 100 KHz for the sections 5.c) and 5.d) above, since RBW=100 KHZ is available on nearly all spectrum analyzers.

## 4.3 DEVIATION FROM STANDARD

No deviation.

## 4.4 TEST SETUP



## 4.5 EUT OPERATION CONDITIONS



The EUT tested system was configured as the statements of 2.1 Unless otherwise a special operating condition is specified in the follows during the testing.





4.6 TEST RESULTS

Temperature :	26 °C	Relative Humidity :	54%
Pressure :	1015 hPa	Test Voltage :	DC 5V
Test Mode :	TX Frequency Band IV (5745-5825MHz)		

Mode	Frequency	Measured Power Density (dBm/300kHz)	Factor	Measured Power Density (dBm/500kHz)	Limit (dBm/500kHz)
802.11 a	5745 MHz	-4.515	2.22	-2.295	30
	5785 MHz	-7.176	2.22	-4.956	30
	5825 MHz	-7.089	2.22	-4.869	30
802.11 n20	5745 MHz	-3.742	2.22	-1.522	30
	5785 MHz	-4.648	2.22	-2.428	30
	5825 MHz	-5.485	2.22	-3.265	30
802.11 n40	5755 MHz	-8.975	2.22	-6.755	30
	5795 MHz	-7.051	2.22	-4.831	30
802.11 AC80	5775 MHz	-3.276	2.22	-1.056	30

Note: Maximum PSD=PSD(dBm/300kHz)+10log(500kHz/300kHz)=2.22



(802.11a) PSD plot on channel 149



(802.11n20) PSD plot on channel 149



(802.11a) PSD plot on channel 157



(802.11n20) PSD plot on channel 157

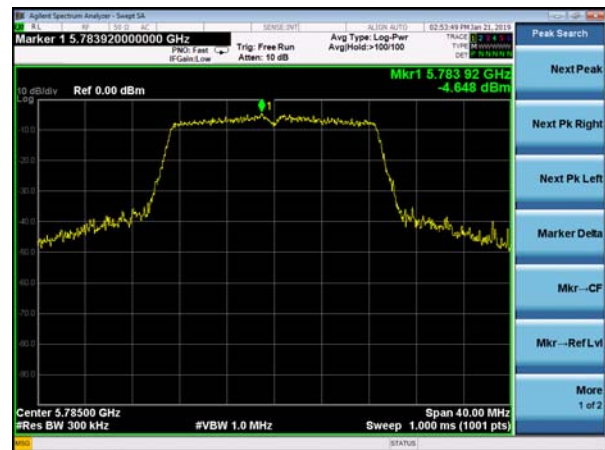

(802.11a) PSD plot on channel 165

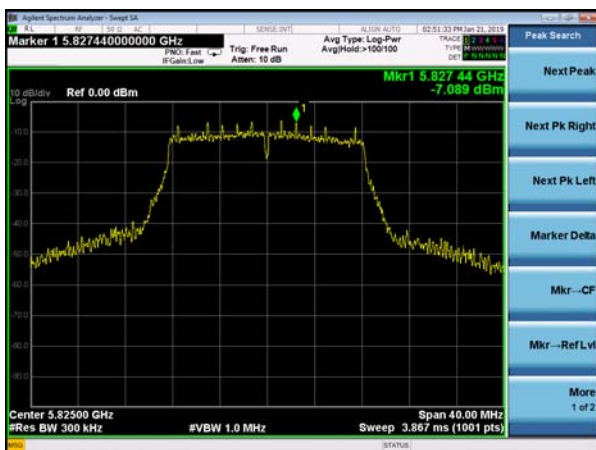

(802.11n20) PSD plot on channel 165

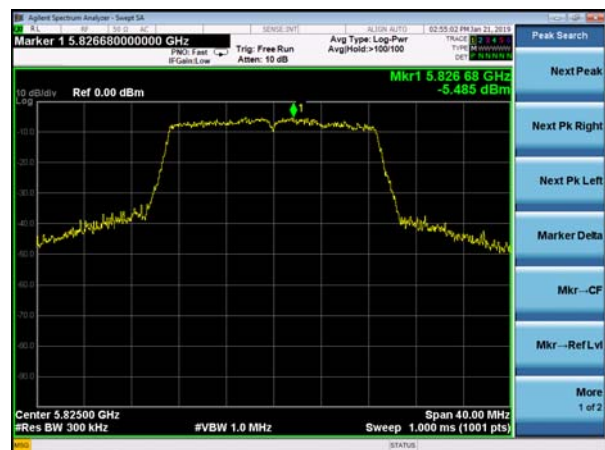



(802.11n40) PSD plot on channel 151



(802.11ac80) PSD plot on channel 155



(802.11n40) PSD plot on channel 159





## 5. 6DB & 99% EMISSION BANDWIDTH

### 5.1 APPLIED PROCEDURES / LIMIT

The maximum power spectral density is measured as a conducted emission by direct connection of a calibrated test instrument to the equipment under test. If the device cannot be connected directly, alternative techniques acceptable to the Commission may be used. Measurements in the 5.725-5.85 GHz band, the minimum bandwidth 6 dB bandwidth of U-NII devices shall be at least 500KHz. Measurements in the 5.15-5.25 GHz, 5.25-5.35 GHz, and the 5.47-5.725 GHz bands are made over a bandwidth of 1 MHz or the 26 dB emission bandwidth of the device, whichever is less. A narrower resolution bandwidth can be used, provided that the measured power is integrated over the full reference bandwidth.

### 5.2 TEST PROCEDURE



- a) Set RBW = 100KHz.
- b) Set the VBW > RBW.
- c) Detector = Peak.
- d) Trace mode = max hold.
- e) Measure the maximum width of the emission that is constrained by the frequencies associated with the two outermost amplitude points (upper and lower frequencies) that are attenuated by 6 dB relative to the maximum level measured in the fundamental emission.

The following procedure shall be used for measuring (99 %) power bandwidth:

1. Set center frequency to the nominal EUT channel center frequency.
2. Set span = 1.5 times to 5.0 times the OBW.
3. Set RBW = 1 % to 5 % of the OBW
4. Set VBW  $\geq 3 \cdot$  RBW
5. Video averaging is not permitted. Where practical, a sample detection and single sweep mode shall be used. Otherwise, peak detection and max hold mode (until the trace stabilizes) shall be used.
6. Use the 99 % power bandwidth function of the instrument (if available).
7. If the instrument does not have a 99 % power bandwidth function, the trace data points are recovered and directly summed in power units. The recovered amplitude data points, beginning at the lowest frequency, are placed in a running sum until 0.5 % of the total is reached; that frequency is recorded as the lower frequency. The process is repeated until 99.5 % of the total is reached; that frequency is recorded as the upper frequency. The 99% occupied bandwidth is the difference between these two frequencies.



### 5.3 EUT OPERATION CONDITIONS

The EUT tested system was configured as the statements of 2.4 Unless otherwise a special operating condition is specified in the follows during the testing.



**5.4 TEST RESULTS**

Temperature :	26 °C	Relative Humidity :	54%
Pressure :	101kPa	Test Voltage :	DC 5V
Test Mode :	TX Frequency Band IV (5745-5825MHz)		

Mode	Channel	Frequency (MHz)	99% bandwidth(MHz)	Result
802.11a	CH149	5745	16.655	Pass
	CH157	5785	16.703	Pass
	CH165	5825	16.660	Pass
802.11 n20	CH149	5745	17.637	Pass
	CH157	5785	17.665	Pass
	CH165	5825	17.657	Pass
802.11 n40	CH151	5755	35.918	Pass
	CH159	5795	35.934	Pass
802.11 AC80	CH155	5775	75.259	Pass

Mode	Channel	Frequency (MHz)	6dB bandwidth (MHz)	Limit (kHz)	Result
802.11a	CH149	5745	16.34	500	Pass
	CH157	5785	16.32	500	Pass
	CH165	5825	16.32	500	Pass
802.11 n20	CH149	5745	17.03	500	Pass
	CH157	5785	17.31	500	Pass
	CH165	5825	17.06	500	Pass
802.11 n40	CH151	5755	35.66	500	Pass
	CH159	5795	35.38	500	Pass
802.11 AC80	CH155	5775	75.23	500	Pass



Test plot

(802.11a) 99%Bandwidth plot on channel 149

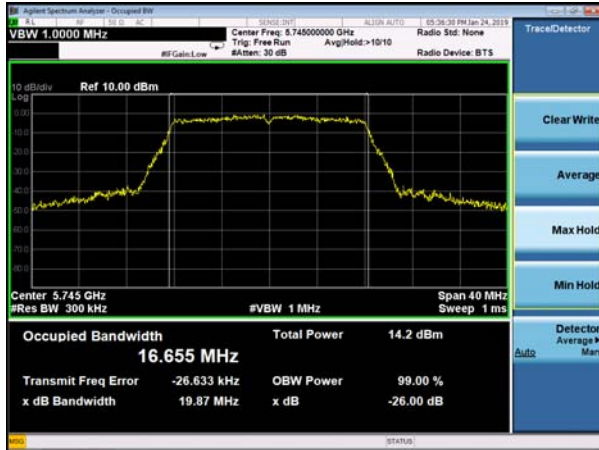

(802.11 n20) 99%Bandwidth plot on channel 149

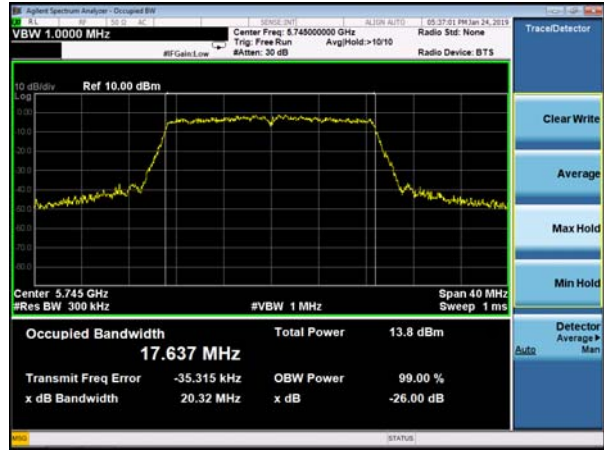

(802.11a) 99%Bandwidth plot on channel 157

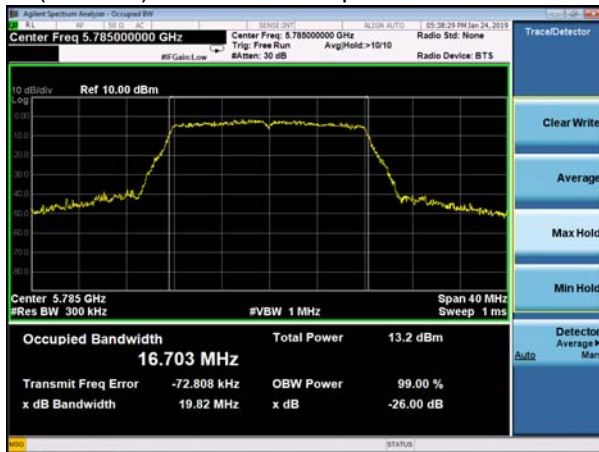

(802.11 n20) 99%Bandwidth plot on channel 157

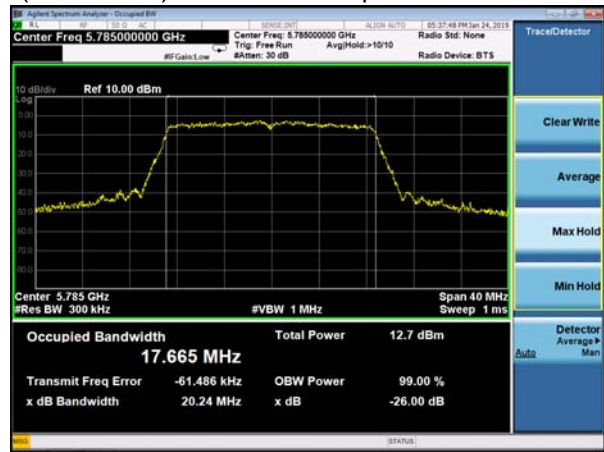

(802.11a) 99%Bandwidth plot on channel 165

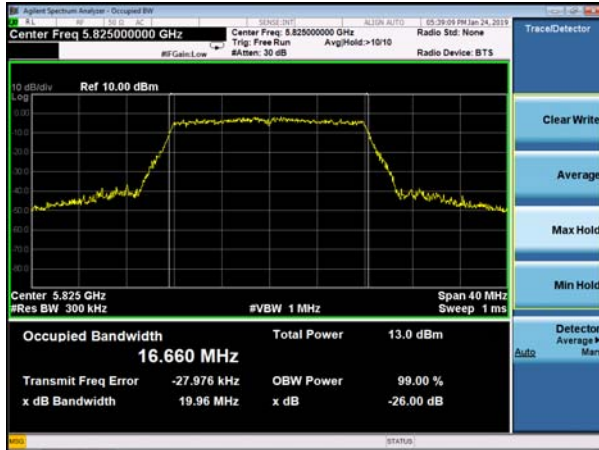

(802.11 n20) 99%Bandwidth plot on channel 165

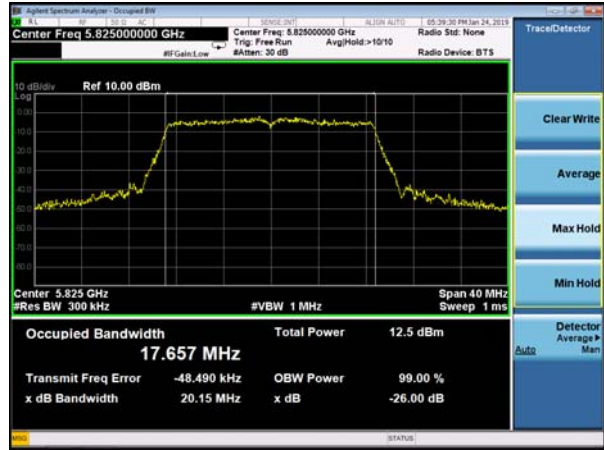



**Test plot**

(802.11 n40) 99%Bandwidth plot on channel 151

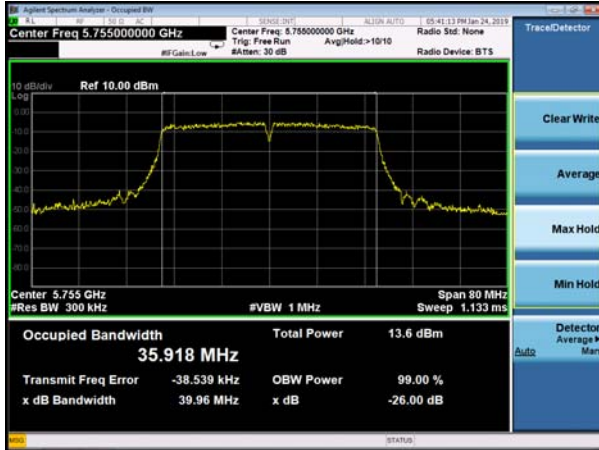

(802.11 AC80) 99%Bandwidth plot on channel 155

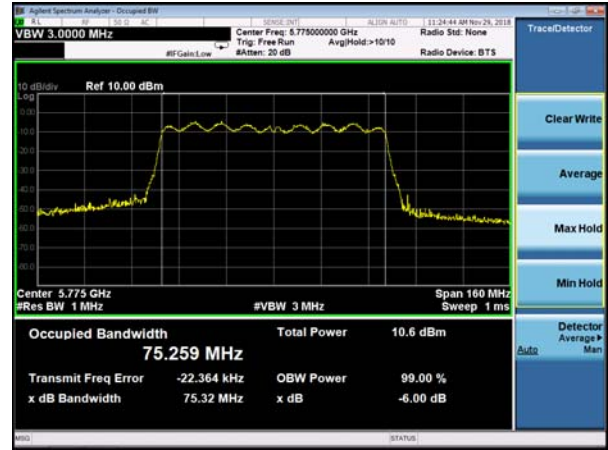

(802.11 n40) 99%Bandwidth plot on channel 159

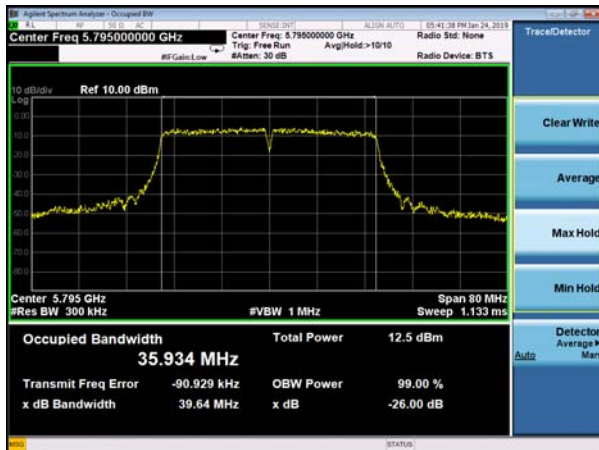





**Test plot**

(802.11a) -6dB Bandwidth plot on channel 149

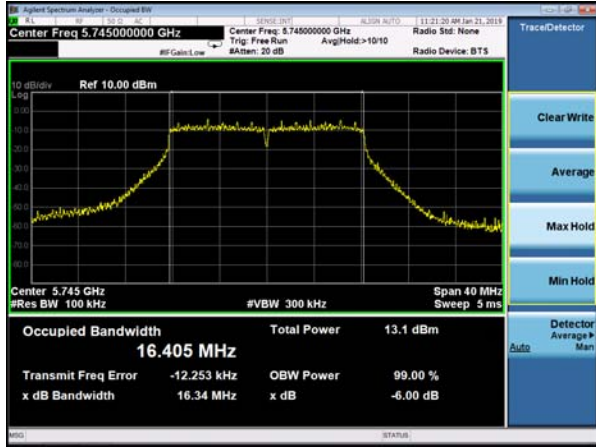

(802.11 n20) -6dB Bandwidth plot on channel 149

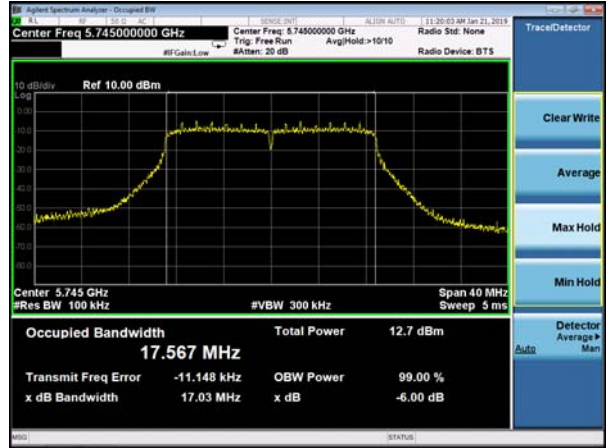

(802.11a) -6dB Bandwidth plot on channel 157

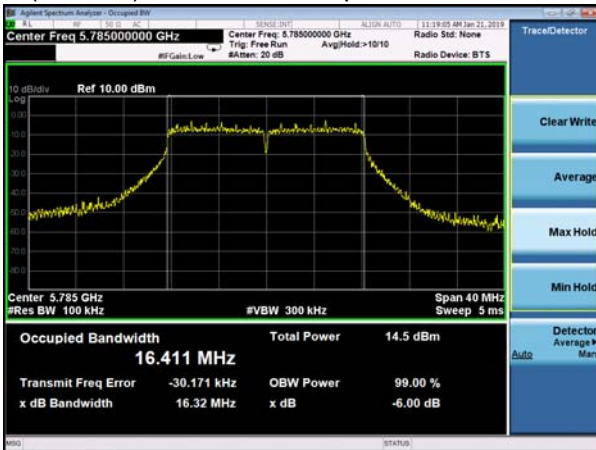

(802.11 n20) -6dB Bandwidth plot on channel 157

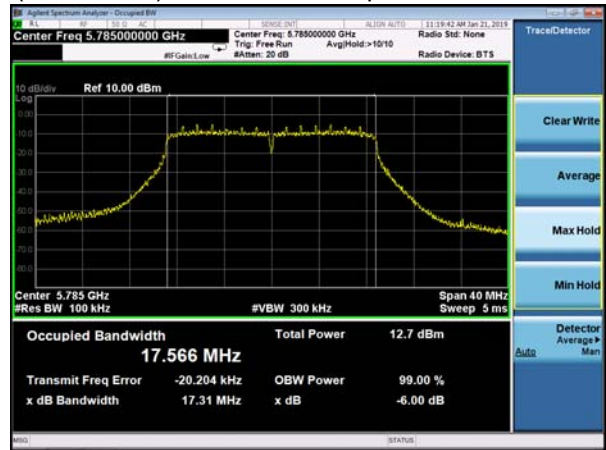

(802.11a) -6dB Bandwidth plot on channel 165

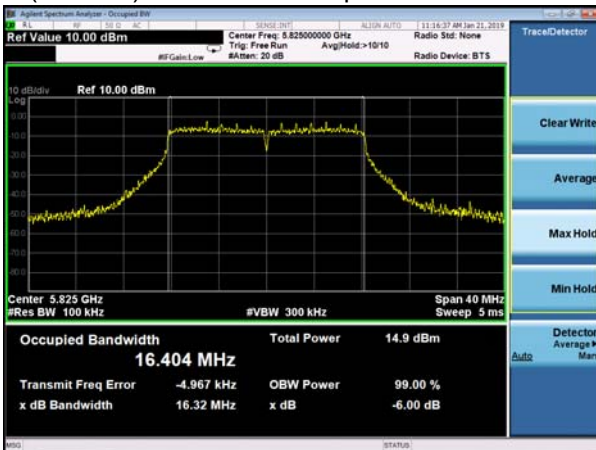

(802.11 n20) -6dB Bandwidth plot on channel 165

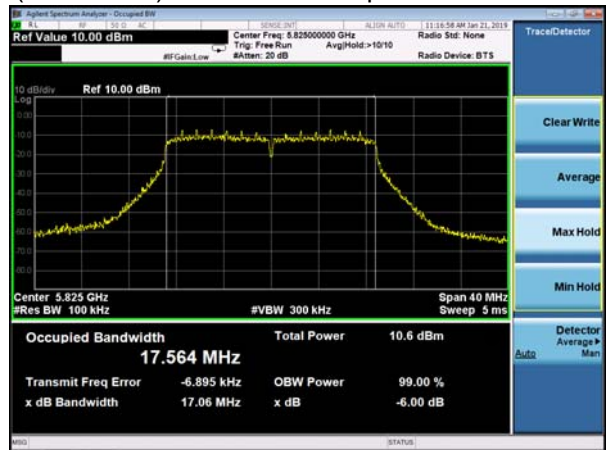



**Test plot**

(802.11 n40) -6dB Bandwidth plot on channel 151

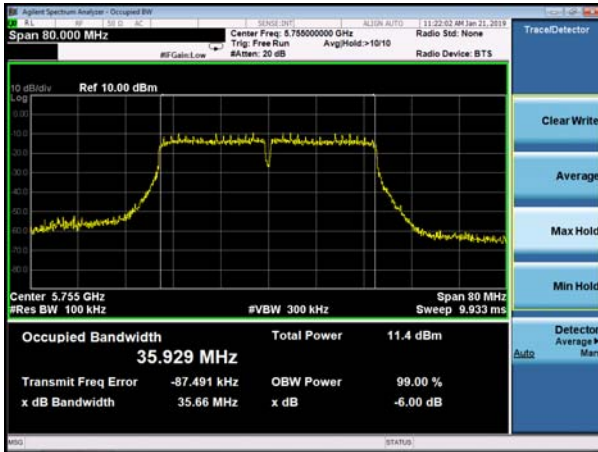

(802.11 AC80) -6dB Bandwidth plot on channel 155

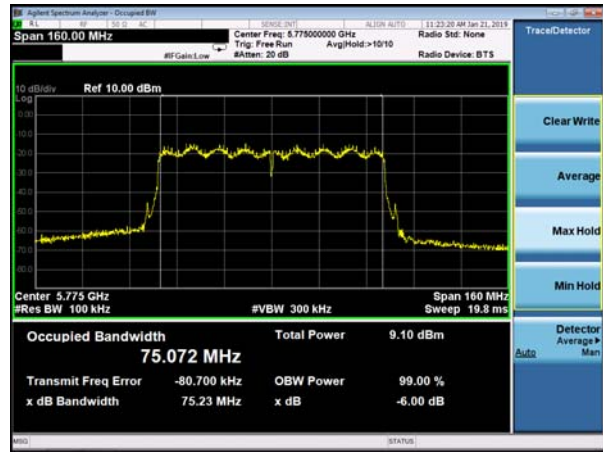

(802.11 n40) -6dB Bandwidth plot on channel 159

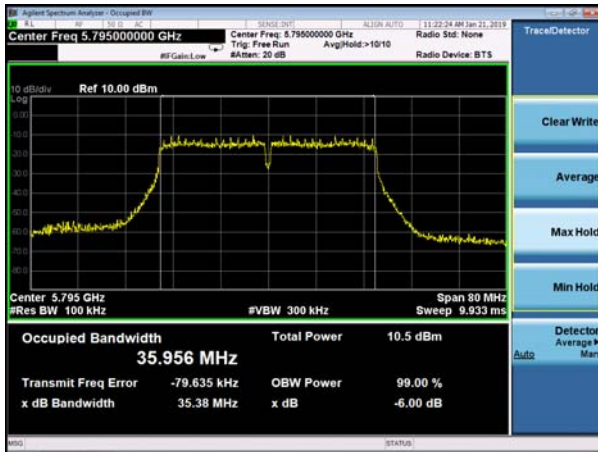



**6. MAXIMUM CONDUCTED OUTPUT POWER**

**6.1 PPLIED PROCEDURES / LIMIT**

According to FCC §15.407

The maximum conducted output power should not exceed:

Frequency Band(MHz)	Limit
5150~5250	1W
5725~5850	1W

The maximum e.i.r.p should not exceed:

Frequency Band(MHz)	Limit
5150~5250	200mW or 10dBm +10logB whichever is less
5725~5850	N/A

Note: Where “B” is the 99% emission bandwidth in MHz

**6.2 TEST PROCEDURE**

- a. The EUT was directly connected to the Power meter

**6.3 DEVIATION FROM STANDARD**

No deviation.

**6.4 TEST SETUP**



**6.5 EUT OPERATION CONDITIONS**

The EUT tested system was configured as the statements of 2.4 Unless otherwise a special operating condition is specified in the follows during the testing.



### 6.6 TEST RESULTS

Temperature :	26 °C	Relative Humidity :	54%
Pressure :	1012 hPa	Test Voltage :	DC 5V
Test Mode :	TX (5G) Mode Frequency Band IV (5725-5825MHz)		

Test Channel	Frequency	Maximum output power. Antenna port (PK)	LIMIT	Result
	(MHz)	(dBm)	dBm	
<b>TX 802.11a Mode</b>				
CH 149	5745	9.58	30	Pass
CH 157	5785	9.55	30	Pass
CH 165	5825	9.85	30	Pass
<b>TX 802.11 n20M Mode</b>				
CH 149	5745	9.40	30	Pass
CH 157	5785	8.73	30	Pass
CH 165	5825	8.43	30	Pass
<b>TX 802.11 n40M Mode</b>				
CH 151	5755	8.33	30	Pass
CH 159	5795	8.64	30	Pass
<b>TX 802.11 AC80M Mode</b>				
CH 155	5775	7.21	30	Pass



## 7. OUT OF BAND EMISSIONS

### 7.1 APPLICABLE STANDARD

#### According to FCC §15.407(b)

Undesirable emission limits. Except as shown in paragraph (b)(7) of this section, the maximum emissions outside of the frequency bands of operation shall be attenuated in accordance with the following limits:

(1) For transmitters operating in the 5.15-5.25 GHz band: All emissions outside of the 5.15-5.35 GHz band shall not exceed an e.i.r.p. of  $-27$  dBm/MHz.

(2) For transmitters operating in the 5.725-5.85 GHz band: All emissions within the frequency range from the band edge to 10 MHz above or below the band edge shall not exceed an e.i.r.p. of  $-17$  dBm/MHz; for frequencies 10 MHz or greater above or below the band edge, emissions shall not exceed an e.i.r.p. of  $-27$  dBm/MHz.

### 7.2 TEST PROCEDURE

1. Check the calibration of the measuring instrument using either an internal calibrator or a known signal from an external generator.
2. Position the EUT without connection to measurement instrument. Turn on the EUT and connect its antenna terminal to measurement instrument via a low loss cable. Then set it to any one measured frequency within its operating range, and make sure the instrument is operated in its linear range.
3. Set RBW of spectrum analyzer to 1 MHz with a convenient frequency span.
4. Measure the highest amplitude appearing on spectral display and set it as a reference level. Plot the graph with marking the highest point and edge frequency.
5. Repeat above procedures until all measured frequencies were complete.

### 7.3 DEVIATION FROM STANDARD

No deviation.

### 7.4 TEST SETUP



### 7.5 EUT OPERATION CONDITIONS

The EUT tested system was configured as the statements of 2.4 Unless otherwise a special operating condition is specified in the follows during the testing.



**7.6 TEST RESULTS**

Temperature :	26 °C	Relative Humidity :	54%
Pressure :	1012 hPa	Test Voltage :	DC 5V

*Out of Band edge  
or the frequency band 5.725-5.850GHz (802.11a)*

Test CH.	Test Segment	Result	Limit
	MHz	dBm/MHz	dBm/MHz
Lowest	Below 5715	-57.192	-27
	5715 to 5725	-43.946	-17
Highest	5850 to 5860	-58.158	-17
	Above 5860	-63.251	-27

Note: the data just list the worst cases

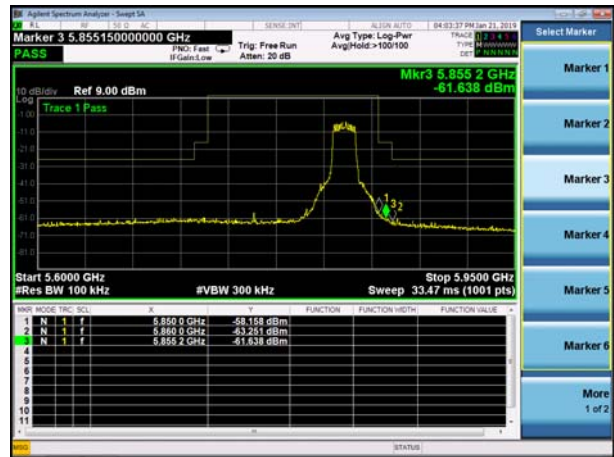
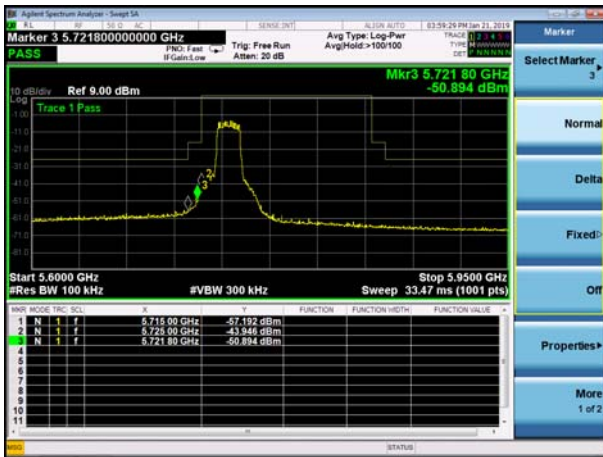

*For the frequency band 5.725-5.850GHz (802.11n20)*

Test CH.	Test Segment	Result	Limit
	MHz	dBm/MHz	dBm/MHz
Lowest	Below 5715	-58.256	-27
	5715 to 5725	-46.039	-17
Highest	5850 to 5860	-60.919	-17
	Above 5860	-65.122	-27

Note: the data just list the worst cases

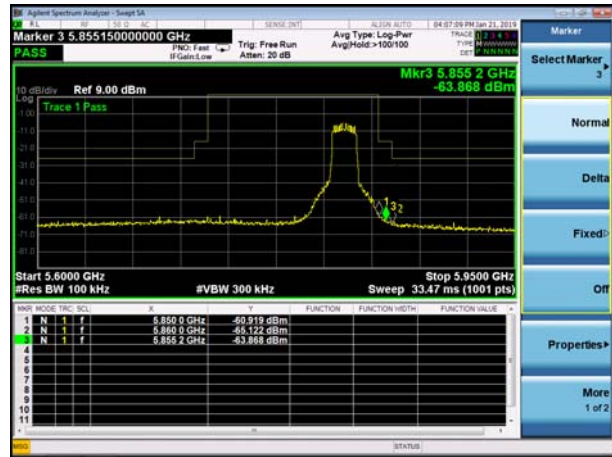
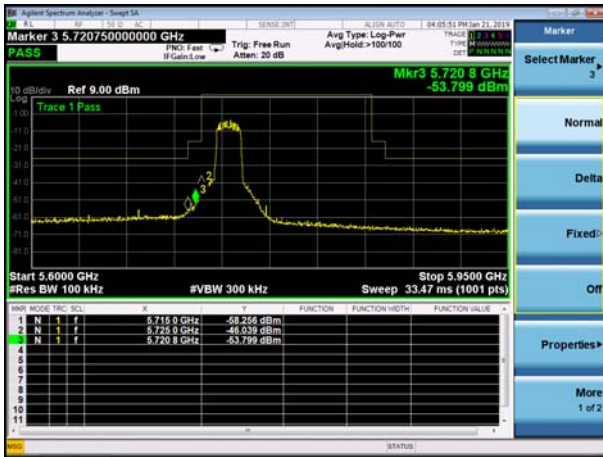

For the frequency band 5.725-5.850GHz (802.11n40)

Test CH.	Test Segment		Result	Limit
	MHz		dBm/MHz	dBm/MHz
Lowest	Below 5715		-51.536	-27
	5715 to 5725		-49.804	-17
Highest	5850 to 5860		-60.908	-17
	Above 5860		-65.754	-27

Note: the data just list the worst cases

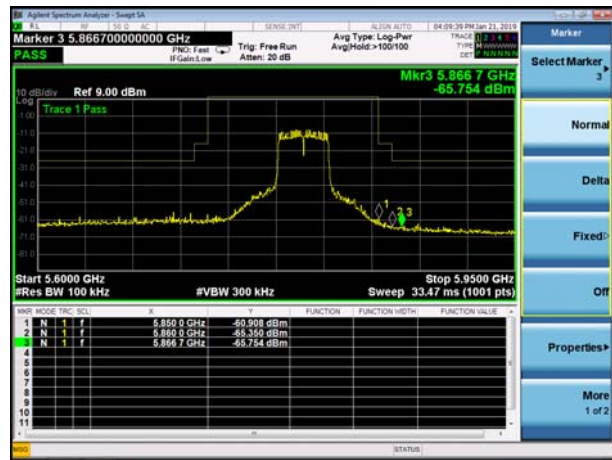
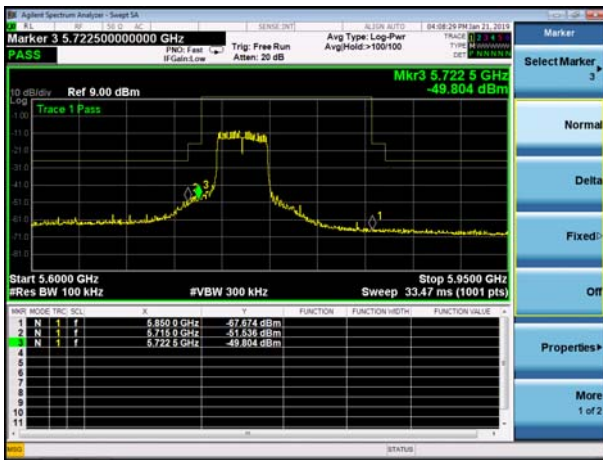



For the frequency band 5.725-5.850GHz (802.11ac80)

Test CH.	Test Segment	Result	Limit
	MHz	dBm/MHz	dBm/MHz
Lowest	Below 5715	-44.953	-27
	5715 to 5725	-44.182	-17
Highest	5850 to 5860	-54.191	-17
	Above 5860	-54.853	-27

Note: the data just list the worst cases

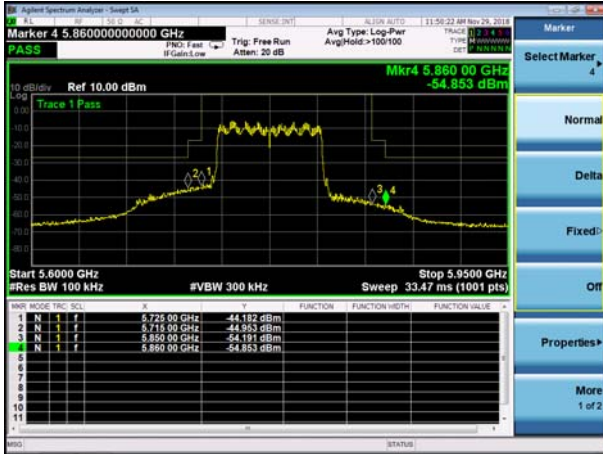





## 8. SPURIOUS RF CONDUCTED EMISSIONS

### 8.1 CONFORMANCE LIMIT

1. Below -20dB of the highest emission level in operating band.
2. Fall in the restricted bands listed in section 15.205. The maximum permitted average field strength is listed in section 15.209.

### 8.2 MEASURING INSTRUMENTS

The Measuring equipment is listed in the section 6.3 of this test report.

### 8.3 TEST SETUP

Please refer to Section 6.1 of this test report.

### 8.4 TEST PROCEDURE

The Spurious RF conducted emissions compliance of RF radiated emission should be measured by following the guidance in ANSI C63.10-2013 with respect to maximizing the emission by rotating the EUT, measuring the emission while the EUT is situated in three orthogonal planes (if appropriate), adjusting the measurement antenna height and polarization etc. Set RBW=100kHz and VBW= 300KHz to measure the peak field strength , and measure frequency range from 9KHz to 26.5GHz.

### 8.5 TEST RESULTS

Remark: The measurement frequency range is from 9KHz to the 10th harmonic of the fundamental frequency. The lowest, middle and highest channels are tested to verify the spurious emissions and band edge measurement data.



5.8G  
Test Plot

802.11a on channel 149

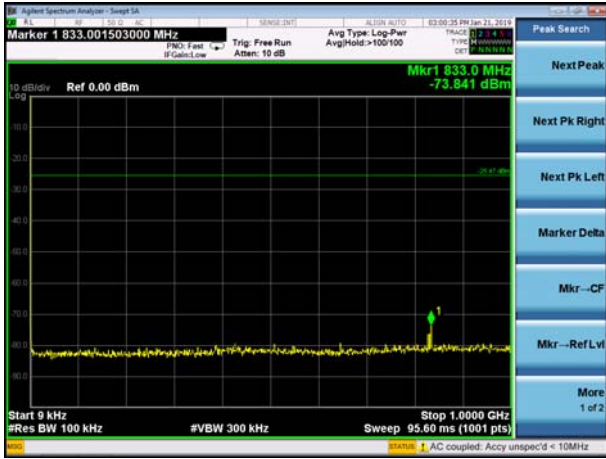

802.11a on channel 157

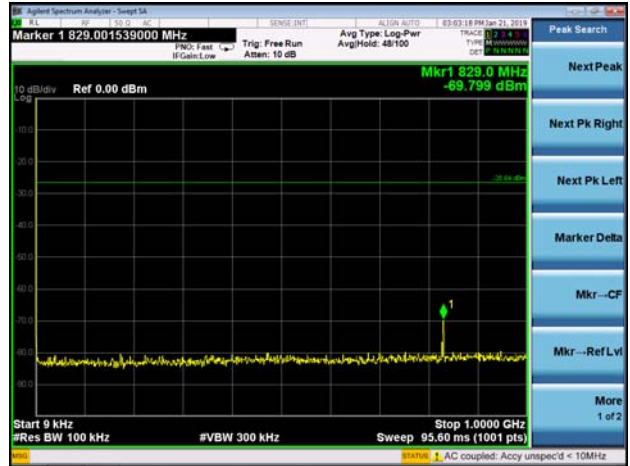

802.11a on channel 149



802.11a on channel 157

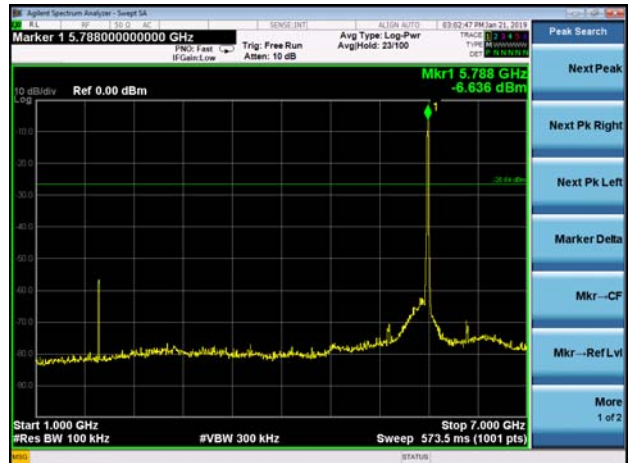

802.11a on channel 149



802.11a on channel 157





Test Plot

802.11a on channel 165

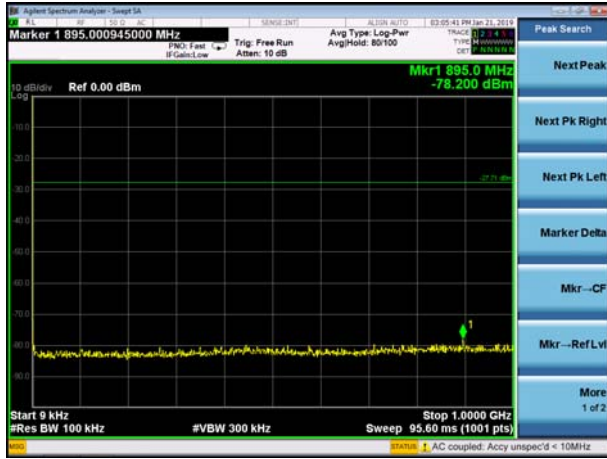

802.11n20 on channel 149

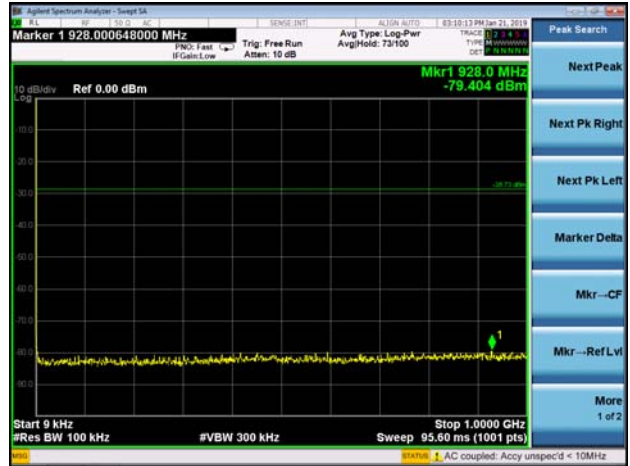

802.11a on channel 165



802.11n20 on channel 149



802.11a on channel 165



802.11n20 on channel 149





Test Plot

802.11n20 on channel 157

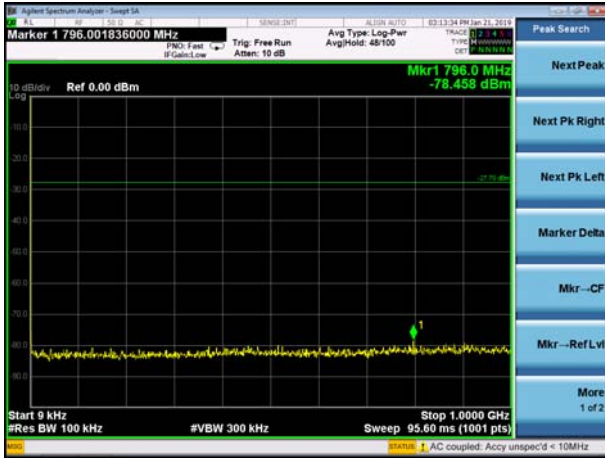

802.11n20 on channel 165

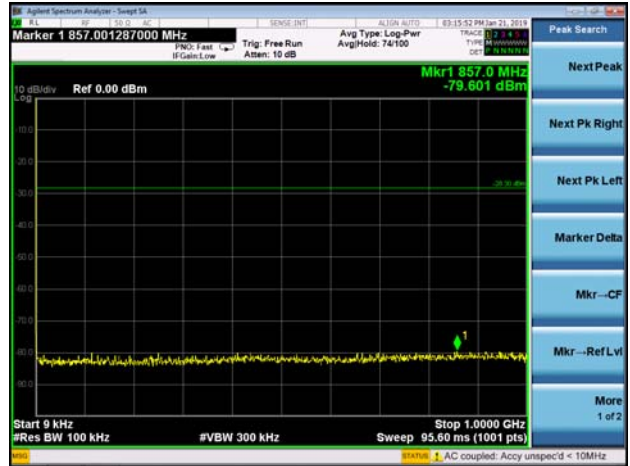

802.11n20 on channel 157



802.11n20 on channel 165



802.11n20 on channel 157



802.11n20 on channel 165





Test Plot

802.11n40 on channel 151

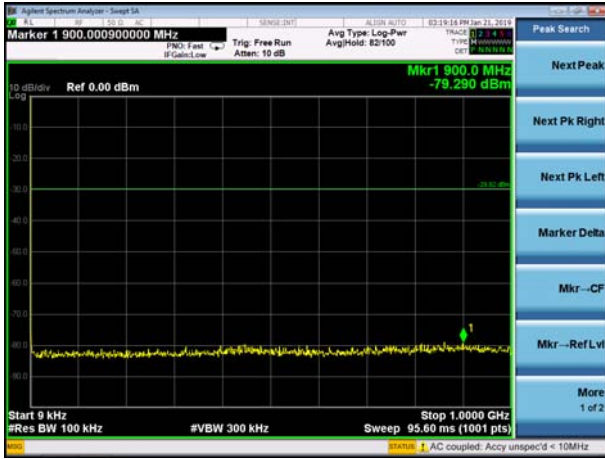

802.11n40 on channel 159

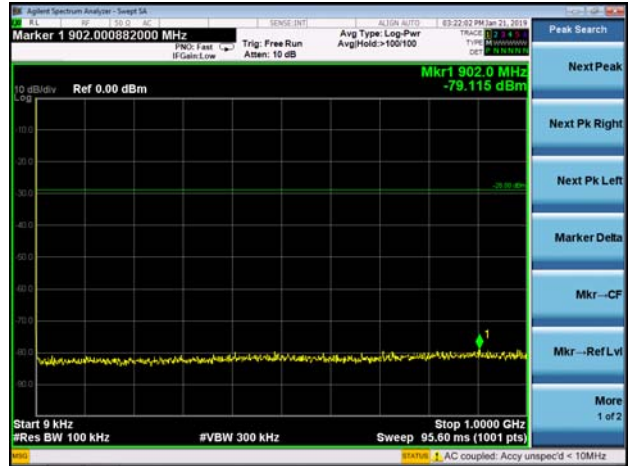

802.11n40 on channel 151



802.11n40 on channel 159



802.11n40 on channel 151



802.11n40 on channel 159





### Test Plot

802.11ac80 on channel 155

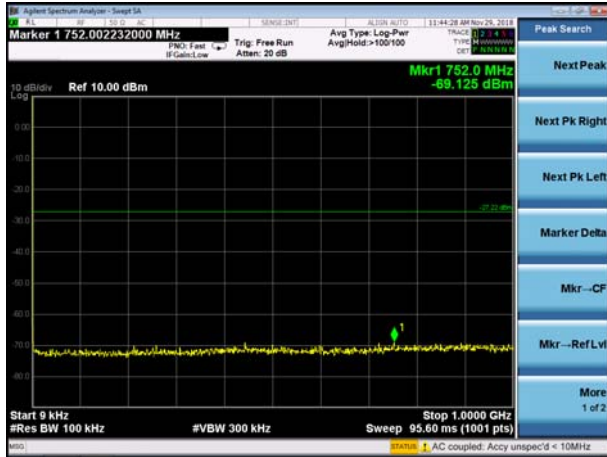

802.11 ac80 on channel 155

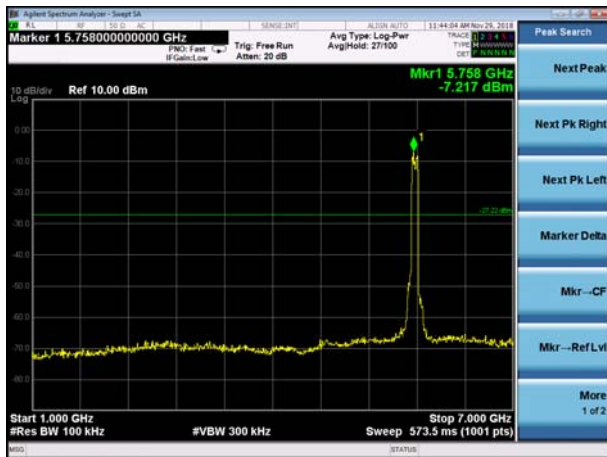

802.11 ac80 on channel 155



## 9. Frequency Stability Measurement

### 9.1 LIMIT

Manufactures of U-NII devices are responsible for ensuring frequency stability such that an emission is maintained within the band of operation under all conditions of normal operation as specified in the user's manual.

The transmitter center frequency tolerance shall be  $\pm 20$  ppm maximum for the 5 GHz band (IEEE 802.11n specification).

### 9.2 TEST PROCEDURES

1. The transmitter output (antenna port) was connected to the spectrum analyzer.
2. EUT have transmitted absence of modulation signal and fixed channelize.
3. Set the spectrum analyzer span to view the entire absence of modulation emissions bandwidth.
4. Set RBW = 10 kHz, VBW = 10 kHz with peak detector and maxhold settings.
5.  $f_c$  is declaring of channel frequency. Then the frequency error formula is  $(f_c - f) / f_c \times 10^6$  ppm and the limit is less than  $\pm 20$  ppm (IEEE 802.11n specification).
6. The test extreme voltage is to change the primary supply voltage from 85 to 115 percent of the nominal value
7. Extreme temperature is  $-20^\circ\text{C} \sim 70^\circ\text{C}$ .

### 9.3 TEST SETUP LAYOUT

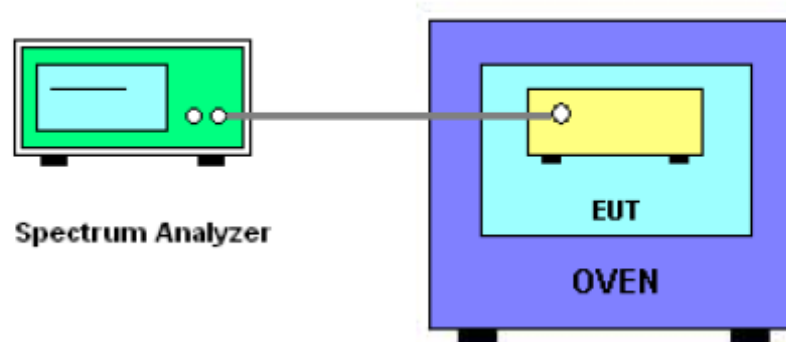

### 9.4 EUT OPERATION DURING TEST

The EUT was programmed to be in continuously un-modulation transmitting mode.



9.5 TEST RESULTS

Temperature :	26 °C	Relative Humidity :	54%
Pressure :	1012 hPa	Test Voltage :	DC 5V
Test Mode :	TX Frequency(5745-5850MHz)		

5745-5825MHz  
802.11a\_HT20

Reference Frequency(Middle Channel): 5785 MHz			
Environment Temperature (°C)	Power Supplied (VDC)	Frequency Measure with Time Elapsed	
		MCF	Error (ppm)
50	5	63	0.01089
40	5	51	0.00882
30	5	43	0.00743
20	5	32	0.00553
10	5	23	0.00398
0	5	26	0.00449
-10	5	22	0.00380
-20	5	36	0.00622
-30	5	43	0.00743





802.11n\_HT20

Reference Frequency(Middle Channel): 5785MHz			
Environment Temperature (°C)	Power Supplied (VDC)	Frequency Measure with Time Elapsed	
		MCF	Error (ppm)
50	5	55	0.00951
40	5	42	0.00726
30	5	32	0.00553
20	5	24	0.00415
10	5	22	0.00380
0	5	12	0.00207
-10	5	13	0.00225
-20	5	21	0.00363
-30	5	32	0.00553

802.11n\_HT40

Reference Frequency(Middle Channel): 5795MHz			
Environment Temperature (°C)	Power Supplied (VDC)	Frequency Measure with Time Elapsed	
		MCF	Error (ppm)
50	5	61	0.01053
40	5	54	0.00932
30	5	42	0.00725
20	5	44	0.00759
10	5	34	0.00587
0	5	32	0.00552
-10	5	34	0.00587
-20	5	42	0.00725
-30	5	51	0.00880



802.11ac80

Reference Frequency(Middle Channel): 5775MHz			
Environment Temperature (°C)	Power Supplied (VDC)	Frequency Measure with Time Elapsed	
		MCF	Error (ppm)
50	5	63	0.01091
40	5	52	0.00900
30	5	43	0.00745
20	5	41	0.00710
10	5	36	0.00623
0	5	32	0.00554
-10	5	34	0.00589
-20	5	43	0.00745
-30	5	52	0.00900



So, Frequency Stability Versus Input Voltage is:  
5745-5825MHz  
802.11a\_HT20

Reference Frequency(Middle Channel): 5785 MHz			
Environment Temperature (°C)	Power Supplied (VDC)	Frequency Measure with Time Elapsed	
		Frequency	Error (ppm)
20	4.5	34	0.00588
	5	32	0.00553
	5.5	33	0.00570

802.11n\_HT20

Reference Frequency(Middle Channel): 5785 MHz			
Environment Temperature (°C)	Power Supplied (VDC)	Frequency Measure with Time Elapsed	
		Frequency	Error (ppm)
20	4.5	55	0.00951
	5	21	0.00363
	5.5	43	0.00743

802.11n\_HT40

Reference Frequency(Middle Channel): 5795 MHz			
Environment Temperature (°C)	Power Supplied (VDC)	Frequency Measure with Time Elapsed	
		Frequency	Error (ppm)
20	4.5	42	0.00725
	5	44	0.00759
	5.5	42	0.00725

802.11ac80

Reference Frequency(Middle Channel): 5775 MHz			
Environment Temperature (°C)	Power Supplied (VDC)	Frequency Measure with Time Elapsed	
		Frequency	Error (ppm)
20	4.5	42	0.00727
	5	44	0.00762
	5.5	42	0.00727



## 10. ANTENNA REQUIREMENT

### 10.1 STANDARD REQUIREMENT

15.203 requirement: For intentional device, according to 15.203: an intentional radiator shall be designed to ensure that no antenna other than that furnished by the responsible party shall be used with the device.

### 10.2 EUT ANTENNA

The EUT antenna is External antenna with RP-SMA connector, the Antenna 1(long) support for 5.8G gain is 2dBi, the Antenna 2 support(box) for 5.8G, gain is 2dBi, It comply with the standard requirement.



## 11. EUT TEST PHOTO

### Conducted Measurement Photos (ANT1)



### Conducted Measurement Photos (ANT2)





**Radiated Measurement Photos(ANT1)**



**Radiated Measurement Photos(ANT2)**

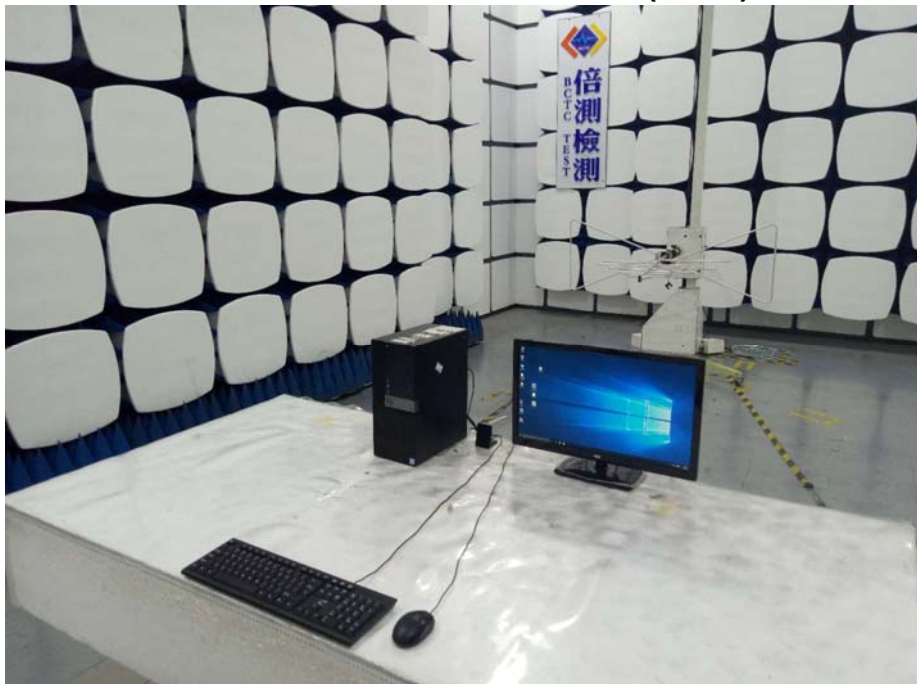



**Radiated Measurement Photos(ANT1)**

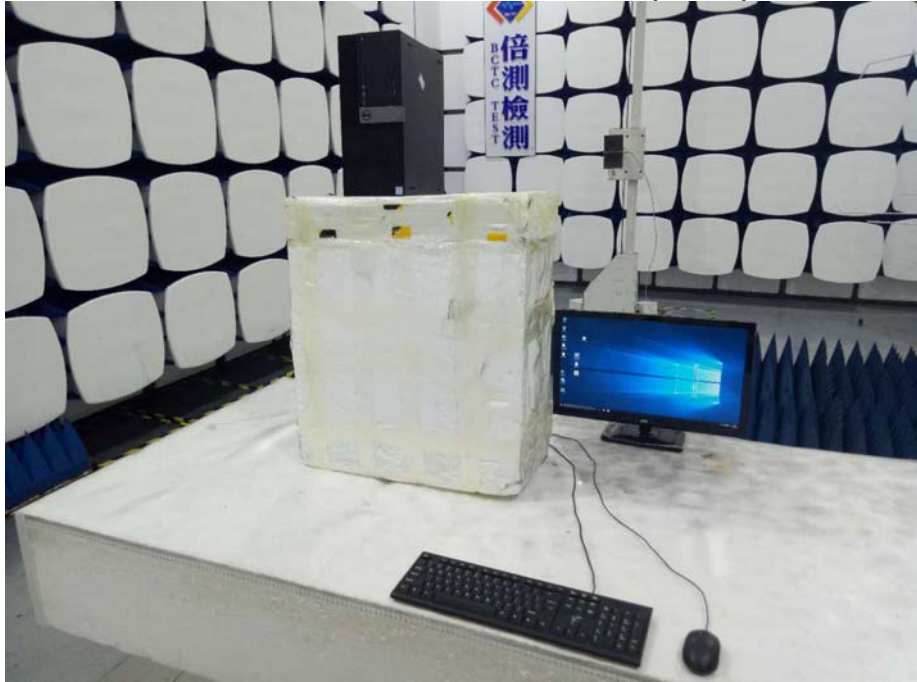

**Radiated Measurement Photos(ANT2)**

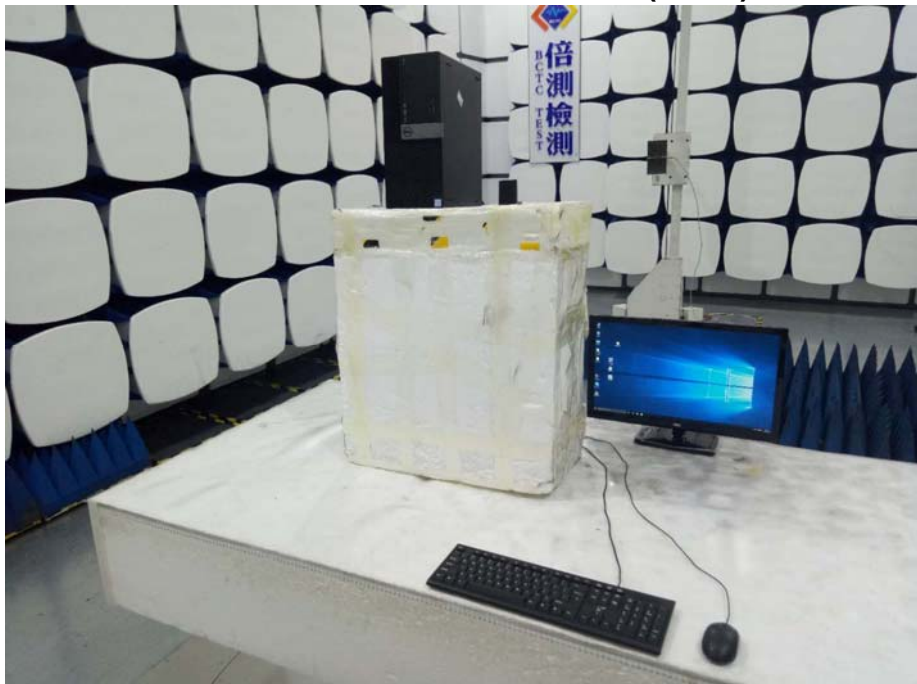



**Radiated Measurement Photos(ANT1)**



**Radiated Measurement Photos(ANT2)**

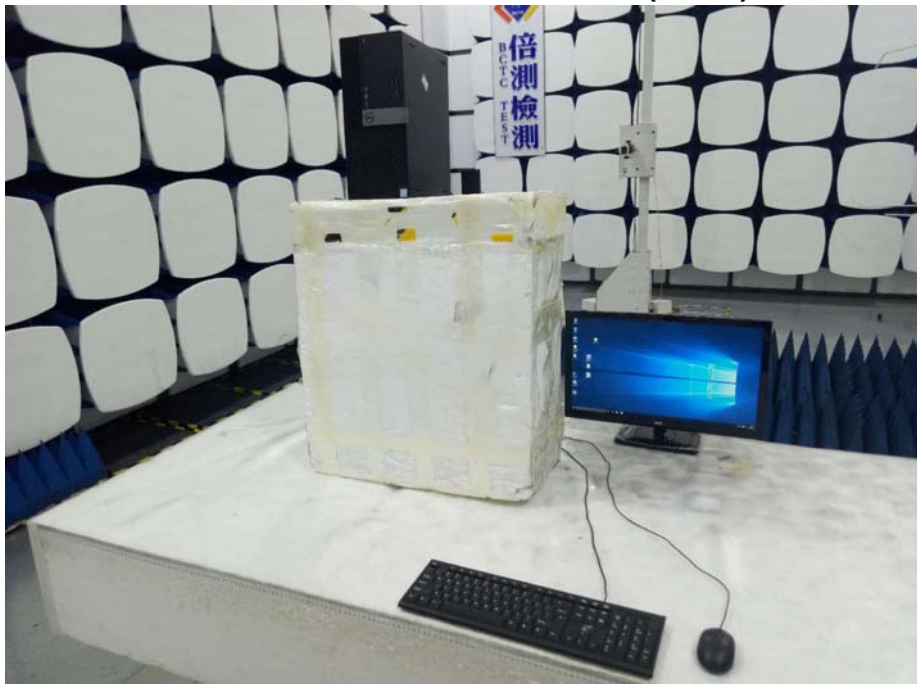



## 12. EUT PHOTO

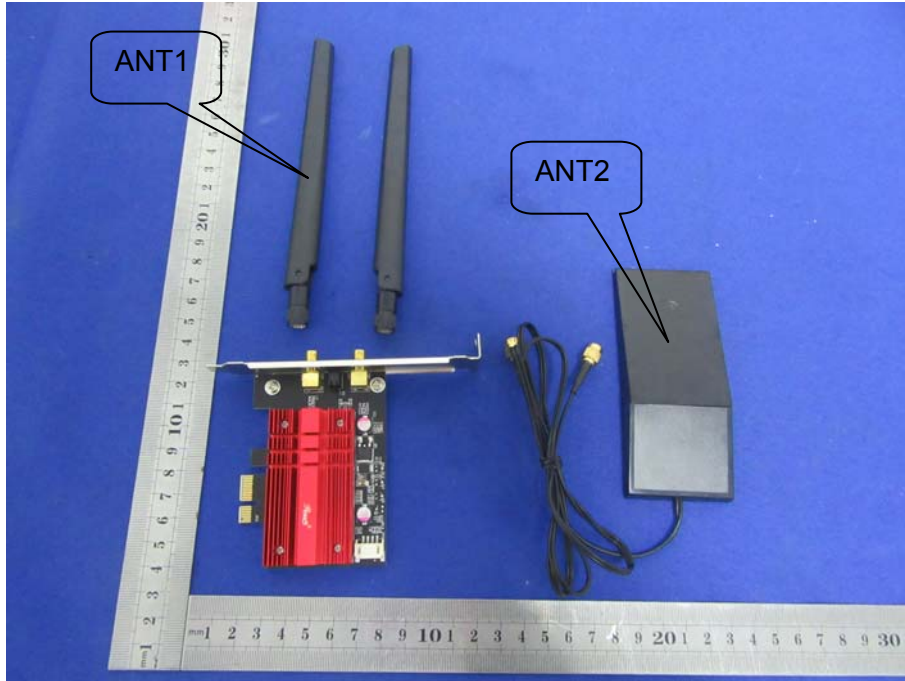

\*\*\*\*\* END OF REPORT \*\*\*\*\*