



FCC ID: W5Y-1002244
 Report No.: T191120D05-RP8

IC: 24213-1002244

Page: 1 / 82
 Rev.: 03

**FCC 47 CFR PART 27 SUBPART C, L
 &
 INDUSTRY CANADA RSS-130**

TEST REPORT

For

GUARDIAN SYSTEM LTE

**FCC Model No.: G2-SY-CON2
 IC Model No.: G2-SY-CON2-1002244**

Trade Name: GUARDIAN

Issued to

FCC:	Seeing Machines Pty Ltd 80 Mildura Street, Fyshwick, ACT , Canberra 2609 Australia
IC:	Seeing Machines Ltd. 80 Mildura Street Fyshwick ACT 2609 Australia

Issued by

**Compliance Certification Services Inc.
 Wugu Laboratory
 No.11, Wugong 6th Rd., Wugu Dist.,
 New Taipei City, Taiwan. (R.O.C.)
 Issued Date: June 20, 2020**

Unless otherwise stated the results shown in this test report refer only to the sample(s) tested and such sample(s) are retained for 90 days only.

除非另有說明，此報告結果僅對測試之樣品負責，同時此樣品僅保留90天。本報告未經本公司書面許可，不可部份複製。

This document is issued by the Company subject to its General Conditions of Service printed overleaf, available on request or accessible at <http://www.sgs.com.tw/Terms-and-Conditions> and, for electronic format documents, subject to Terms and Conditions for Electronic Documents at <http://www.sgs.com.tw/Terms-and-Conditions>. Attention is drawn to the limitation of liability, indemnification and jurisdiction issues defined therein. Any holder of this document is advised that information contained hereon reflects the Company's findings at the time of its intervention only and within the limits of client's instruction, if any. The Company's sole responsibility is to its Client and this document does not exonerate parties to a transaction from exercising all their rights and obligations under the transaction documents. This document cannot be reproduced, except in full, without prior written approval of the Company. Any unauthorized alteration, forgery or falsification of the content or appearance of this document is unlawful and offenders may be prosecuted to the fullest extent of the law.

Revision History

Rev.	Issue Date	Revisions	Effect Page	Revised By
00	January 22, 2020	Initial Issue	ALL	Doris Chu
01	April 22, 2020	See the following Note Rev. (01)	P.6, P.11, P.13, P.16-19, P.20-22, P.24, P.30, P.57-73, P.75-76, P.77	Doris Chu
02	April 28, 2020	See the following Note Rev. (02)	P.6, P.30-31, P.34-35, P.38-39	Doris Chu
03	June 20, 2020	See the following Note Rev. (03)	P.1, P.4, P.6	Allison Chen

Rev (01):

1. Revised LTE Band 12 1.4MHz Frequency Range.
2. Revised Antenna type.
3. Revised section 5.2 DC Power Supplies Cal Due date indication.
4. Added section 6.3.
5. Revised LTE Band 12 EIRP Power to ERP Power.
6. Revised section 8.2 Limit.
7. Revised section 8.2 Test Procedure and Test Results.
8. Revised section 8.3 test results.
9. Revised section 8.4 test results frequency.
10. The worst case in section 8.6 is 1RB
11. Added section 8.7 Test Configuration.
12. Revised section 8.7 test results.

Rev (02):

1. Revised section 2 power supply.
2. Revised section 8.4 100%RB to FULL RB.

Rev (03):

1. Modify IC Model No.: G2-SY-CON2-1002244.

TABLE OF CONTENTS

1.	TEST RESULT CERTIFICATION	4
2.	EUT DESCRIPTION	6
3.	TEST METHODOLOGY	7
3.1	DESCRIPTION OF TEST TYPE	7
3.2	THE WORST MODE OF MEASUREMENT	8
4.	TEST SUMMARY	9
5.	INSTRUMENT CALIBRATION.....	10
5.1	FACILITIES AND TEST LOCATION.....	10
5.2	MEASUREMENT EQUIPMENT USED	11
5.3	MEASUREMENT UNCERTAINTY.....	12
6.	FACILITIES AND ACCREDITATIONS.....	13
6.1	FACILITIES	13
6.2	EQUIPMENT	13
7.	SETUP OF EQUIPMENT UNDER TEST	14
7.1	SETUP CONFIGURATION OF EUT	14
7.2	SUPPORT EQUIPMENT	14
8.	TEST PROCEDURE AND RESULT	15
8.1	ERP & EIRP MEASUREMENT	15
8.2	FREQUENCY STABILITY MEASUREMENT	20
8.3	OCCUPIED BANDWIDTH MEASUREMENT	23
8.4	PEAK TO AVERAGE POWER RATIO.....	29
8.5	BAND EDGE MEASUREMENT	40
8.6	CONDUCTED SPURIOUS EMISSIONS.....	57
8.7	RADIATED EMISSION MEASUREMENT	74
APPENDIX A PHOTOGRAPHS OF TEST SETUP		A-1

1. TEST RESULT CERTIFICATION

FCC Applicant: Seeing Machines Pty Ltd
80 Mildura Street, Fyshwick, ACT , Canberra 2609 Australia

IC Applicant: Seeing Machines Ltd.
80 Mildura Street Fyshwick ACT 2609 Australia

Manufacturer: ADLINK TECHNOLOGY INC.
9F, No. 166, Jian Yi Rd., Zhonghe Dist., New Taipei City, 235
Taiwan

Equipment Under Test: GUARDIAN SYSTEM LTE

Trade Name: GUARDIAN

FCC Model No.: G2-SY-CON2

IC Model No.: G2-SY-CON2-1002244

Date of Test: December 19, 2019 ~January 8, 2020

APPLICABLE STANDARDS	
Standard	TEST RESULT
FCC Part 27, Subpart C, L, FCC Part 2 & RSS-130 Issue 2 February 2019	No non-compliance noted
Statements of Conformity	
Determination of compliance is based on the results of the compliance measurement, not taking into account measurement instrumentation uncertainty.	

The above equipment has been tested by Compliance Certification Services Inc., and found compliance with the requirements set forth in the technical standards mentioned above. The results of testing in this report apply only to the product/system, which was tested. Other similar equipment will not necessarily produce the same results due to production tolerance and measurement uncertainties.

Approved by:



Kevin Tsai
Deputy Manager
Compliance Certification Services Inc.

2. EUT DESCRIPTION

Product	GUARDIAN SYSTEM LTE		
FCC Model No.	G2-SY-CON2		
IC Model No.	G2-SY-CON2-1002244		
Model Discrepancy	N/A		
Trade	GUARDIAN		
Received Date	November 20, 2019		
Power Supply	Powered from DC supply: DC 12V.		
Modulation Technology	LTE Band 12	QPSK, 16QAM	
Frequency Range	LTE Band 12 Channel Bandwidth: 1.4MHz	699.7 MHz ~ 715.3MHz	
	LTE Band 12 Channel Bandwidth: 3MHz	700.5MHz ~ 714.5MHz	
	LTE Band 12 Channel Bandwidth: 5MHz	701.5MHz ~ 713.5MHz	
	LTE Band 12 Channel Bandwidth: 10MHz	704MHz ~ 711MHz	
Transmit Power (ERP Power)	LTE Band 12 Channel Bandwidth: 1.4MHz	QPSK	20.70 dBm
		16QAM	20.52 dBm
	LTE Band 12 Channel Bandwidth: 3MHz	QPSK	20.72 dBm
		16QAM	20.54 dBm
	LTE Band 12 Channel Bandwidth: 5MHz	QPSK	20.74 dBm
		16QAM	20.56 dBm
	LTE Band 12 Channel Bandwidth: 10MHz	QPSK	20.81 dBm
		16QAM	20.63 dBm
Antenna Specification	Dipole Antenna Antenna gain: 1.0 dBi		
HW Version	V1		
SW Version	V9		

Note: 1. The above EUT information was declared by manufacturer and for more detailed features description, please refer to the manufacturer's specifications or User's Manual.

3. TEST METHODOLOGY

3.1 DESCRIPTION OF TEST TYPE

The EUT had been tested under operating condition.

Software used to control the EUT for staying in continuous transmitting mode was programmed.

LTE Band 12: 699 MHz ~ 716 MHz

Three channels had been tested for each channel bandwidth.

Channel Bandwidth	1.4MHz		3MHz		5MHz		10MHz	
	Channel	Frequency (MHz)	Channel	Frequency (MHz)	Channel	Frequency (MHz)	Channel	Frequency (MHz)
Low CH	23017	699.7	23025	700.5	23035	701.5	23060	704
Middle CH	23095	707.5	23095	707.5	23095	707.5	23095	707.5
High CH	23173	715.3	23165	714.5	23155	713.5	23130	711

Report No.: T191120D05-RP8

3.2 THE WORST MODE OF MEASUREMENT

Radiated Emission Measurement Above 1G	
Test Condition	Radiated Emission Above 1G
Power supply Mode	Mode 1: EUT power by Power supply
Worst Mode	<input checked="" type="checkbox"/> Mode 1 <input type="checkbox"/> Mode 2 <input type="checkbox"/> Mode 3 <input type="checkbox"/> Mode 4
Worst Position	<input type="checkbox"/> Placed in fixed position. <input checked="" type="checkbox"/> Placed in fixed position at X-Plane (E2-Plane) <input type="checkbox"/> Placed in fixed position at Y-Plane (E1-Plane) <input type="checkbox"/> Placed in fixed position at Z-Plane (H-Plane)

Radiated Emission Measurement Below 1G	
Test Condition	Radiated Emission Below 1G
Power supply Mode	Mode 1: EUT power by Power supply
Worst Mode	<input checked="" type="checkbox"/> Mode 1 <input type="checkbox"/> Mode 2 <input type="checkbox"/> Mode 3 <input type="checkbox"/> Mode 4

Remark:

1. The worst mode was record in this test report.
2. EUT pre-scanned in three axis ,X,Y, Z and two polarity, for radiated measurement. The worst case(X-Plane) were recorded in this report

4. TEST SUMMARY

FCC Standard Section	IC Standard Section	Report Section	Test Item	Result
-	-	2	Antenna Requirement	Pass
27.50(c)	RSS-130, section 4.6	8.1	ERP and EIRP Measurement	Pass
2.1055, 27.54	RSS-130 section 4.3	8.2	Frequency Stability v.s. temperature measurement	Pass
2.1049	RSS-GEN 6.7	8.3	Occupied Bandwidth Measurement	Pass
27.50(b)	RSS-130 section 4.4	8.4	Peak to Average Ratio	Pass
27.53(g)	RSS-130 section 4.6	8.5	Conducted Band Edge	Pass
27.53(g)	RSS-130 section 4.6	8.6	Conducted Spurious Emission	Pass
27.53(g)	RSS-130 section 4.6	8.7	Spurious Radiation Measurement	Pass

5. INSTRUMENT CALIBRATION

5.1 FACILITIES AND TEST LOCATION

All measurement facilities used to collect the measurement data are located at
No.11, Wugong 6th Rd., Wugu Dist., New Taipei City, Taiwan. (R.O.C.)

Test site	Test Engineer	Remark
Radiation	Jerry Chang	-
RF Conducted	Dally Hong	-

Remark: The sites are constructed in conformance with the requirements of ANSI C63.7, ANSI C63.4 and CISPR Publication 22.

5.2 MEASUREMENT EQUIPMENT USED

Equipment Used for Emissions Measurement

Remark: Each piece of equipment is scheduled for calibration once a year.

RF Conducted Test Site					
Equipment	Manufacturer	Model	S/N	Cal Date	Cal Due
Coaxial Cable	Woken	WC12	CC001	06/28/2019	06/27/2020
Coaxial Cable	Woken	WC12	CC003	06/28/2019	06/27/2020
Power Divider	Solvang Technology	STI08-0015	008	08/06/2019	08/05/2020
Signal Analyzer	R&S	FSV 40	101073	09/25/2019	09/24/2020
Wideband Radio Communication Tester	R&S	CMW 500	116875	07/29/2019	07/28/2020
DC Power Supplies	GW Instek	SPS-3610	GPE880163	01/14/2019	01/13/2020
Software	N/A				

3M 966 Chamber Test Site					
Equipment	Manufacturer	Model	S/N	Cal Date	Cal Due
Band Reject Filters	MICRO TRONICS	BRM 50702	120	02/26/2019	02/25/2020
Bilog Antenna	Sunol Sciences	JB3	A030105	07/26/2019	07/25/2020
Coaxial Cable	HUBER SUHNER	SUCOFLEX 104PEA	20995	02/26/2019	02/25/2020
Coaxial Cable	EMCI	EMC105	190914+25111	09/20/2019	09/19/2020
Digital Thermo-Hygro Meter	WISEWIND	1206	D07	01/30/2019	01/29/2020
double Ridged Guide Horn Antenna	ETC	MCTD 1209	DRH13M02003	10/04/2019	10/03/2020
Loop Ant	COM-POWER	AL-130	121051	03/22/2019	03/21/2020
Pre-Amplifier	EMEC	EM330	060609	02/26/2019	02/25/2020
Pre-Amplifier	HP	8449B	3008A00965	02/26/2019	02/25/2020
Wideband Radio Communication Tester	R&S	CMW 500	116875	07/29/2019	07/28/2020
PSA Series Spectrum Analyzer	Agilent	E4446A	MY46180323	05/29/2019	05/28/2020
Antenna Tower	CCS	CC-A-1F	N/A	N.C.R	N.C.R
Controller	CCS	CC-C-1F	N/A	N.C.R	N.C.R
Turn Table	CCS	CC-T-1F	N/A	N.C.R	N.C.R
Software	e3 6.11-20180413				

5.3 MEASUREMENT UNCERTAINTY

PARAMETER	UNCERTAINTY
AC Powerline Conducted Emission	+/- 1.2575
Emission bandwidth, 20dB bandwidth	+/- 0.0014
RF output power, conducted	+/- 1.14
Power density, conducted	+/- 1.40
3M Semi Anechoic Chamber / 30M~200M	+/- 4.12
3M Semi Anechoic Chamber / 200M~1000M	+/- 4.68
3M Semi Anechoic Chamber / 1G~8G	+/- 5.18
3M Semi Anechoic Chamber / 8G~18G	+/- 5.47
3M Semi Anechoic Chamber / 18G~26G	+/- 3.81
3M Semi Anechoic Chamber / 26G~40G	+/- 3.87

Remark: This uncertainty represents an expanded uncertainty expressed at approximately the 95% confidence level using a coverage factor of $k=2$.

6. FACILITIES AND ACCREDITATIONS

6.1 FACILITIES

All measurement facilities used to collect the measurement data are located at

No.199, Chunghsen Road, Hsintien City, Taipei Hsien, Taiwan, R.O.C.

Tel: 886-2-2217-0894 / Fax: 886-2-2217-1029

No.11, Wugong 6th Rd., Wugu Dist., New Taipei City, Taiwan. (R.O.C.)

Tel: 886-2-2299-9720 / Fax: 886-2-2298-4045

The sites are constructed in conformance with the requirements of ANSI C63.7, ANSI C63.10: 2013 and CISPR Publication 22.

6.2 EQUIPMENT

Radiated emissions are measured with one or more of the following types of linearly polarized antennas: tuned dipole, biconical, log periodic, bi-log, and/or ridged waveguide, horn. Spectrum analyzers with pre-selectors and quasi-peak detectors are used to perform radiated measurements.

Conducted emissions are measured with Line Impedance Stabilization Networks and EMI Test Receivers.

Calibrated wideband preamplifiers, coaxial cables, and coaxial attenuators are also used for making measurements.

All receiving equipment conforms to CISPR Publication 16-1, "Radio Interference Measuring Apparatus and Measurement Methods."

6.3 LABORATORY ACCREDITATIONS AND LISTING

The test facilities used to perform radiated and conducted emissions tests are accredited by American Association for Laboratory Accreditation Program for the specific scope accreditation under Lab Code: 0824-01 to perform Electromagnetic Interference tests according to FCC Part 15 and CISPR 22 requirements. In addition, the test facilities are listed with Industry Canada, Certification and Engineering Bureau, ISED#: 2324G.

7. SETUP OF EQUIPMENT UNDER TEST

7.1 SETUP CONFIGURATION OF EUT

See test photographs attached in Appendix I for the actual connections between EUT and support equipment.

7.2 SUPPORT EQUIPMENT

No.	Equipment	Brand	Model	Series No.	FCC ID	IC ID
1	NB(J)	TOSHIBA	PT345T-00L002	N/A	PD97260H	1000M-7260H

Remark:

1. *All the equipment/cables were placed in the worst-case configuration to maximize the emission during the test.*
2. *Grounding was established in accordance with the manufacturer's requirements and conditions for the intended use.*

8. TEST PROCEDURE AND RESULT

8.1 ERP & EIRP MEASUREMENT

LIMIT

According to FCC §2.1046

FCC 27.50 (c) (10): The portable stations (hand-held devices) in the 600MHz uplink band and the 698-746MHz band, and fixed and mobile stations in the 600MHz uplink band are limited to 3 Watts ERP.

RSS-130 § 4.6,

The e.r.p. shall not exceed 30 watts for mobile equipment and outdoor fixed subscriber equipment. The e.r.p. shall not exceed 3 watts for portable equipment and indoor fixed subscriber equipment.

TEST PROCEDURES

CONDUCTED POWER MEASUREMENT:

1. The transmitter output power was connected to the call box.
2. Set EUT at maximum output power via call box.
3. Set Call box at lowest, middle and highest channels for each band and modulation.

TEST RESULTS

No non-compliance noted.

Report No.: T191120D05-RP8

TEST RESULTS

LTE Band 12

Band	BW (MHz)	Channel	Frequency (MHz)	Mode	UL RB Allocation	UL RB Start	MPR	Average power(dBm)	ERP Power (dBm)		
Band 12	1.4M	23017	699.7	QPSK	1	0	0	20.57	19.42		
					1	2	0	20.07	18.92		
					1	5	0	20.34	19.19		
					3	0	1	20.58	19.43		
					3	1	1	20.14	18.99		
					3	2	1	20.36	19.21		
		16QAM	6	0	1	20.62	19.47				
			1	0	1	20.84	19.69				
			1	2	1	20.42	19.27				
			1	5	1	20.47	19.32				
			3	0	2	20.39	19.24				
			3	1	2	19.43	18.28				
		23095	707.5	QPSK	QPSK	3	2	2	19.38	18.23	
						6	0	2	19.37	18.22	
						1	0	0	20.82	19.67	
						1	2	0	20.74	19.59	
						1	5	0	20.83	19.68	
						3	0	1	20.81	19.66	
	16QAM	707.5	16QAM	16QAM	3	1	1	20.66	19.51		
					3	2	1	20.90	19.75		
					6	0	1	20.80	19.65		
					1	0	1	20.12	18.97		
					1	2	1	20.40	19.25		
					1	5	1	20.22	19.07		
	23173	715.3	QPSK	QPSK	3	0	2	19.85	18.70		
					3	1	2	19.82	18.67		
					3	2	2	20.00	18.85		
					6	0	2	19.63	18.48		
					1	0	0	21.73	20.58		
					1	2	0	21.85	20.70		
			16QAM	715.3	16QAM	16QAM	1	5	0	21.72	20.57
							3	0	1	20.81	19.66
							3	1	1	20.88	19.73
							3	2	1	20.76	19.61
							6	0	1	20.84	19.69
							1	0	1	21.06	19.91
16QAM	715.3	16QAM	16QAM	1	2	1	21.67	20.52			
				1	5	1	21.16	20.01			
				3	0	2	19.87	18.72			
				3	1	2	19.77	18.62			
				3	2	2	19.79	18.64			
				6	0	2	19.84	18.69			

Band	BW (MHz)	Channel	Frequency (MHz)	Mode	UL RB Allocation	UL RB Start	MPR	Average power(dBm)	ERP Power (dBm)		
Band 12	3M	23025	700.5	QPSK	1	0	0	20.60	19.45		
					1	7	0	20.10	18.95		
					1	14	0	20.37	19.22		
				16QAM	8	0	1	20.61	19.46		
					8	4	1	20.17	19.02		
					8	7	1	20.39	19.24		
				16QAM	15	0	1	20.65	19.50		
					1	0	1	20.87	19.72		
					1	7	1	20.45	19.30		
		1	14		1	20.50	19.35				
		8	0		2	20.42	19.27				
		8	4		2	19.46	18.31				
		23095	707.5	QPSK	707.5	QPSK	8	7	2	19.41	18.26
							8	0	2	19.40	18.25
							15	0	2	19.40	18.25
				16QAM	1	0	0	20.83	19.68		
					1	7	0	20.75	19.60		
					1	14	0	20.84	19.69		
	16QAM			8	0	1	20.82	19.67			
				8	4	1	20.67	19.52			
				8	7	1	20.91	19.76			
		15	0	1	20.81	19.66					
		1	0	1	20.13	18.98					
		1	7	1	20.41	19.26					
	23165	714.5	QPSK	714.5	QPSK	1	14	1	20.23	19.08	
						8	0	2	19.86	18.71	
						8	4	2	19.83	18.68	
			16QAM	8	7	2	20.01	18.86			
				8	0	2	19.64	18.49			
				15	0	2	19.64	18.49			
			QPSK	1	0	0	21.75	20.60			
				1	7	0	21.87	20.72			
				1	14	0	21.74	20.59			
			16QAM	8	0	1	20.83	19.68			
				8	4	1	20.90	19.75			
				8	7	1	20.78	19.63			
15				0	1	20.86	19.71				
1				0	1	21.08	19.93				
1				7	1	21.69	20.54				
1	14	1		21.18	20.03						
8	0	2		19.89	18.74						
8	4	2		19.79	18.64						
8	7	2	19.81	18.66							
15	0	2	19.86	18.71							

Band	BW (MHz)	Channel	Frequency (MHz)	Mode	UL RB Allocation	UL RB Start	MPR	Average power(dBm)	ERP Power (dBm)
Band 12	5M	23035	701.5	QPSK	1	0	0	20.62	19.47
					1	12	0	20.12	18.97
					1	24	0	20.39	19.24
					12	0	1	20.63	19.48
					12	6	1	20.19	19.04
					12	11	1	20.41	19.26
		16QAM	25	0	1	20.67	19.52		
			1	0	1	20.89	19.74		
			1	12	1	20.47	19.32		
			1	24	1	20.52	19.37		
			12	0	2	20.44	19.29		
			12	6	2	19.48	18.33		
		23095	707.5	QPSK	12	11	2	19.43	18.28
					25	0	2	19.42	18.27
					1	0	0	20.84	19.69
					1	12	0	20.76	19.61
					1	24	0	20.85	19.70
					12	0	1	20.83	19.68
	16QAM	12	6	1	20.68	19.53			
		12	11	1	20.92	19.77			
		25	0	1	20.82	19.67			
		1	0	1	20.14	18.99			
		1	12	1	20.42	19.27			
		1	24	1	20.24	19.09			
	23155	713.5	QPSK	12	0	2	19.87	18.72	
				12	6	2	19.84	18.69	
				12	11	2	20.02	18.87	
				25	0	2	19.65	18.50	
				1	0	0	21.77	20.62	
				1	12	0	21.89	20.74	
	16QAM	1	24	0	21.76	20.61			
		12	0	1	20.85	19.70			
		12	6	1	20.92	19.77			
		12	11	1	20.80	19.65			
		25	0	1	20.88	19.73			
		1	0	1	21.10	19.95			
					1	12	1	21.71	20.56
					1	24	1	21.20	20.05
					12	0	2	19.91	18.76
					12	6	2	19.81	18.66
					12	11	2	19.83	18.68
					25	0	2	19.88	18.73

Band	BW (MHz)	Channel	Frequency (MHz)	Mode	UL RB Allocation	UL RB Start	MPR	Average power(dBm)	ERP Power (dBm)
Band 12	10M	23060	704.0	QPSK	1	0	0	20.67	19.52
					1	24	0	20.17	19.02
					1	49	0	20.44	19.29
					25	0	1	20.68	19.53
					25	12	1	20.24	19.09
					25	24	1	20.46	19.31
				16QAM	50	0	1	20.72	19.57
					1	0	1	20.94	19.79
					1	24	1	20.52	19.37
					1	49	1	20.57	19.42
					25	0	2	20.49	19.34
					25	12	2	19.53	18.38
		23095	707.5	QPSK	25	24	2	19.48	18.33
					50	0	2	19.47	18.32
					1	0	0	20.88	19.73
					1	24	0	20.80	19.65
					1	49	0	20.89	19.74
					25	0	1	20.87	19.72
				16QAM	25	12	1	20.72	19.57
					25	24	1	20.96	19.81
					50	0	1	20.86	19.71
					1	0	1	20.18	19.03
					1	24	1	20.46	19.31
					1	49	1	20.28	19.13
		23130	711.0	QPSK	25	0	2	19.91	18.76
					25	12	2	19.88	18.73
					25	24	2	20.06	18.91
					50	0	2	19.69	18.54
					1	0	0	21.84	20.69
					1	24	0	21.96	20.81
				16QAM	1	49	0	21.83	20.68
					25	0	1	20.92	19.77
					25	12	1	20.99	19.84
					25	24	1	20.87	19.72
					50	0	1	20.95	19.80
					1	0	1	21.17	20.02
16QAM	1	24	1	21.78	20.63				
	1	49	1	21.27	20.12				
	25	0	2	19.98	18.83				
	25	12	2	19.88	18.73				
	25	24	2	19.90	18.75				
	50	0	2	19.95	18.80				

8.2 FREQUENCY STABILITY MEASUREMENT

LIMIT

According to the FCC part 27.54 shall be tested the frequency stability. The rule is defined that” The frequency stability shall be sufficient to ensure that the fundamental emissions stay within the authorized bands of operation.

According to RSS -130 section 4.5,

For equipment that is capable of transmitting numerous channels simultaneously for different applications (e.g. LTE and narrowband – Internet of Things (IoT)), the occupied bandwidth shall be the bandwidth representing the sum of the occupied bandwidths of these channels.

The frequency stability shall be sufficient to ensure that the occupied bandwidth remains within each frequency block range when tested at the temperature and supply voltage variations specified in RSS-Gen.

TEST PROCEDURE

Use Anritsu 8820 with frequency Error measurement capability.

Temp = -40°C to +65°C

Voltage= 85% to 115% of the nominal value.

The Worst case: DC 12V

NOTE: *The frequency error was recorded frequency error from the communication simulator.*

Report No.: T191120D05-RP8

TEST RESULTS

FREQUENCY STABILITY V.S. TEMPERATURE MEASUREMENT:

LTE Band 12

Reference Frequency: LTE Band 12 Max Bandwidth QPSK, 707.5 MHz				
Limit: ± 2.5 ppm = 1768.75 Hz				
Power Supply	Environment	Frequency Error	Frequency Error	Limit (ppm)
Vdc	Temperature (°C)	(Hz)	(ppm)	(ppm)
12	65	0.02	0.000028	+/- 2.5
12	50	0.01	0.000014	
12	40	0.00	0.000000	
12	30	0.01	0.000014	
12	20	0.00	0.000000	
12	10	0.00	0.000000	
12	0	0.01	0.000014	
12	-10	-0.01	-0.000014	
12	-20	0.01	0.000014	
12	-30	0.01	0.000014	
12	-40	0.00	0.000000	

Reference Frequency: LTE Band 12 Max Bandwidth 16QAM, 707.5 MHz				
Limit: ± 2.5 ppm = 1768.75 Hz				
Power Supply	Environment	Frequency Error	Frequency Error	Limit (ppm)
Vdc	Temperature (°C)	(Hz)	(ppm)	(ppm)
12	65	0.01	0.000014	+/- 2.5
12	50	0.00	0.000000	
12	40	-0.01	-0.000014	
12	30	-0.01	-0.000014	
12	20	0.00	0.000000	
12	10	0.02	0.000028	
12	0	0.01	0.000014	
12	-10	0.00	0.000000	
12	-20	0.01	0.000014	
12	-30	0.00	0.000000	
12	-40	0.01	0.000014	

**FREQUENCY STABILITY V.S. VOLTAGE MEASUREMENT:
LTE Band 12**

Reference Frequency: LTE Band 12 Max Bandwidth QPSK, 707.5 MHz				
Limit: ± 2.5 ppm = 1768.75 Hz				
Power Supply	Environment	Frequency Error	Frequency Error	Limit (ppm)
Vdc	Temperature (°C)	(Hz)	(ppm)	(ppm)
10.2	20	0.01	0.000014	+/- 2.5
12	20	0.00	0.000000	
13.8	20	0.01	0.000014	

Reference Frequency: LTE Band 12 Max Bandwidth 16QAM, 707.5 MHz				
Limit: ± 2.5 ppm = 1768.75 Hz				
Power Supply	Environment	Frequency Error	Frequency Error	Limit (ppm)
Vdc	Temperature (°C)	(Hz)	(ppm)	(ppm)
10.2	20	0.00	0.000000	+/- 2.5
12	20	0.00	0.000000	
13.8	20	0.01	0.000014	

8.3 OCCUPIED BANDWIDTH MEASUREMENT

LIMITS

The width of a frequency band such that, below the lower and above the upper frequency limits, the mean powers emitted are each equal to a specified percentage 0.5 % of the total mean power of a given emission.

TEST PROCEDURES

KDB 971168 D01 Power Meas License Digital Systems – Section 4.2

1. The occupied bandwidth was measured with the spectrum analyzer at the lowest, middle and highest channels in each band and different modulation. The 99% and -26dB bandwidth was measured and recorded.
2. RBW = 1-5% of the expected OBW
3. VBW \geq 3 x RBW
4. Detector = Peak
5. Trace mode = max. hold

TEST RESULTS

LTE Band 12

Band	BW (MHz)	Channel	Frequency (MHz)	Mode	OBW(99%)(MHz)	26 dB Bandwidth(MHz)
12	1.4	Middle	707.5	QPSK	1.0941	1.3068
		Middle	707.5	16QAM	1.0984	1.3068
	3	Middle	707.5	QPSK	2.6831	2.9305
		Middle	707.5	16QAM	2.6831	2.9219
	5	Middle	707.5	QPSK	4.4718	4.9480
		Middle	707.5	16QAM	4.4718	4.8900
	10	Middle	707.5	QPSK	8.9146	9.6960
		Middle	707.5	16QAM	8.9436	9.7540

Report No.: T191120D05-RP8

LTE Band 12 CHANNEL BANDWIDTH: 1.4MHz / QPSK CH Mid

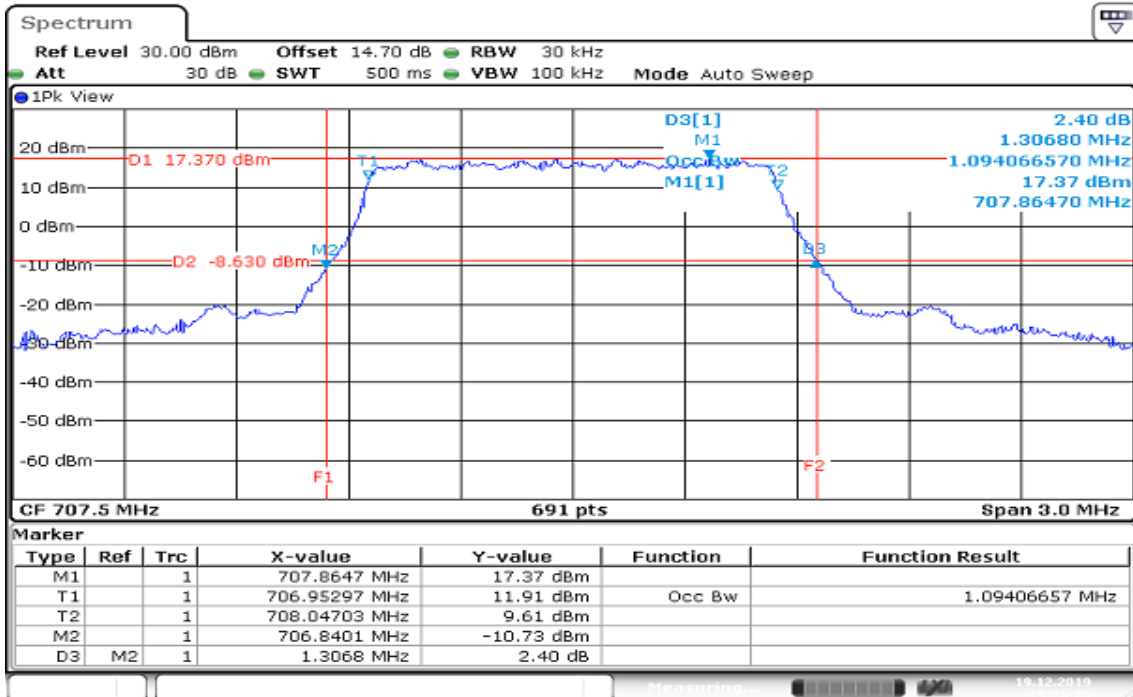

Date: 19.DEC.2019 15:26:06

CHANNEL BANDWIDTH: 1.4MHz / 16QAM CH Mid

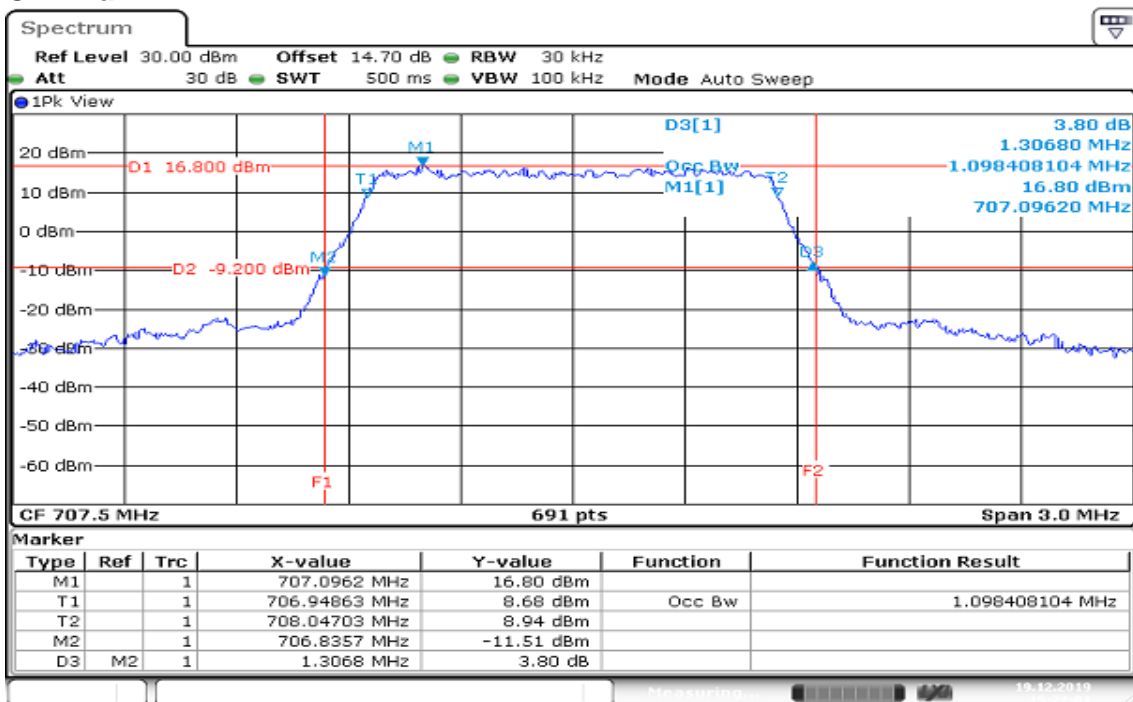

Date: 19.DEC.2019 15:27:01

CHANNEL BANDWIDTH: 3MHz / QPSK CH Mid

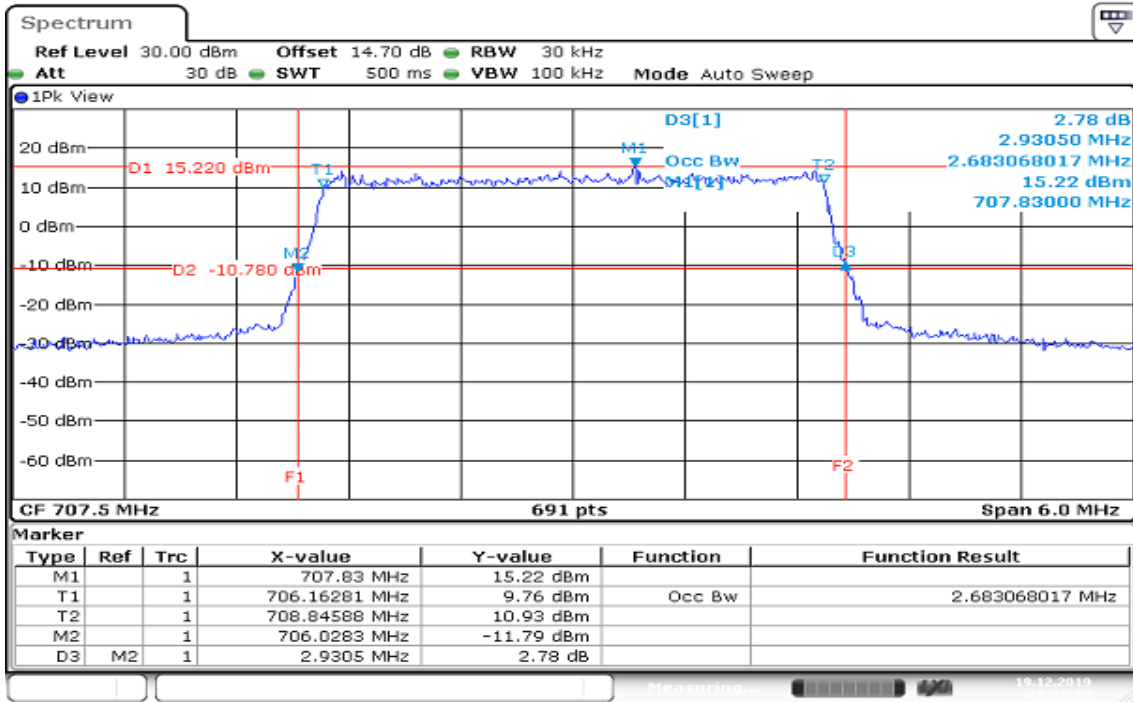

Date: 19.DEC.2019 15:28:14

CHANNEL BANDWIDTH: 3MHz / 16QAM CH Mid

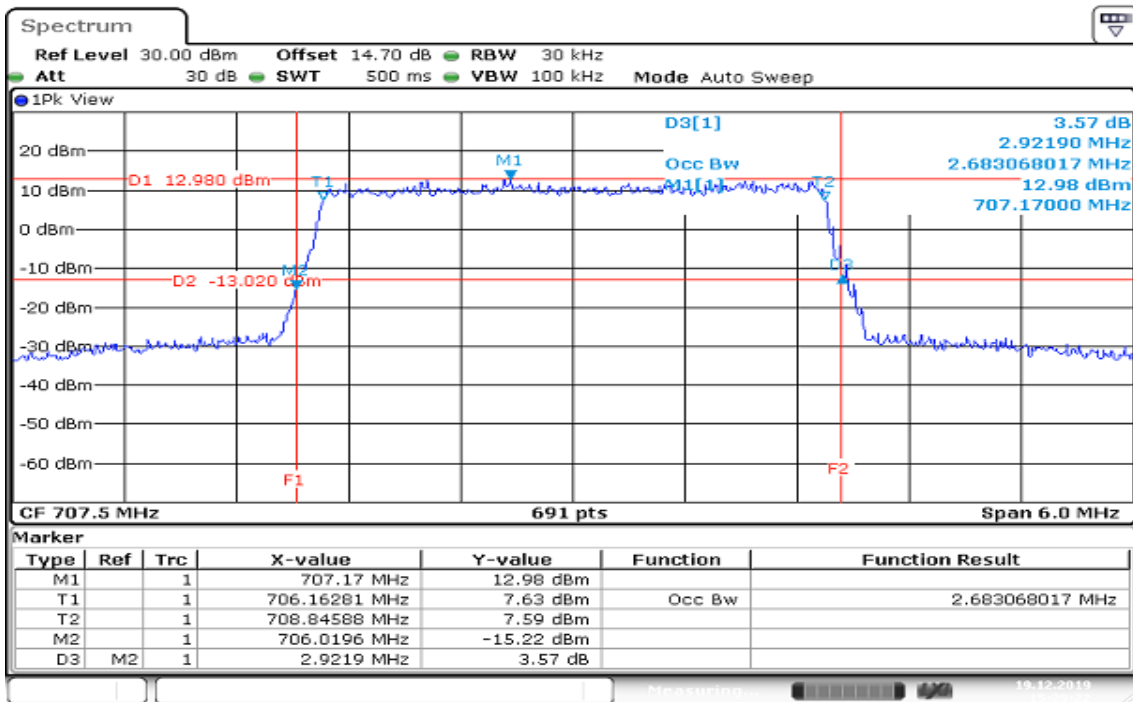

Date: 19.DEC.2019 15:29:23

CHANNEL BANDWIDTH: 5MHz / QPSK CH Mid

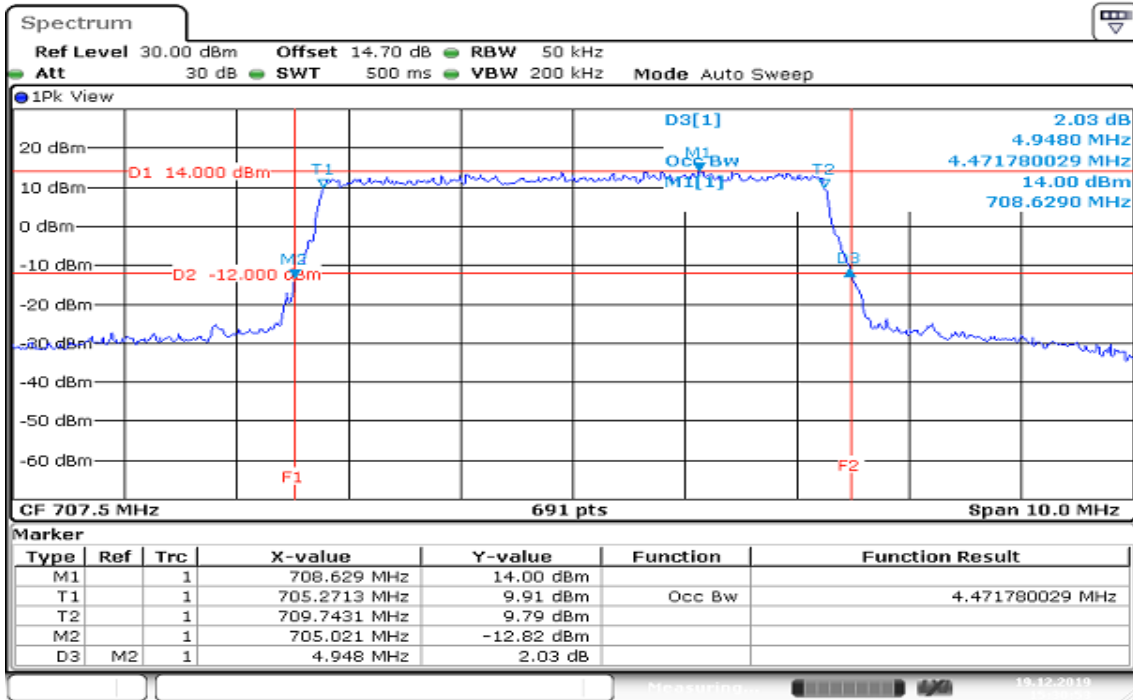

Date: 19.DEC.2019 15:30:54

CHANNEL BANDWIDTH: 5MHz / 16QAM CH Mid

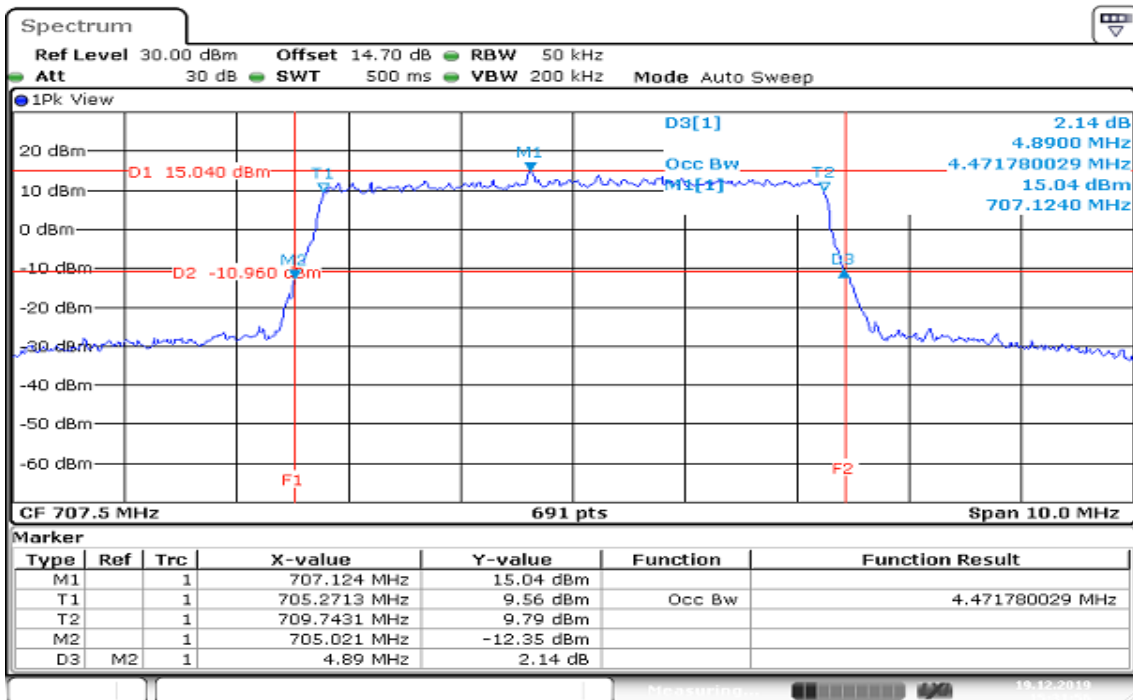

Date: 19.DEC.2019 15:31:57

Report No.: T191120D05-RP8

CHANNEL BANDWIDTH: 10MHz / QPSK CH Mid

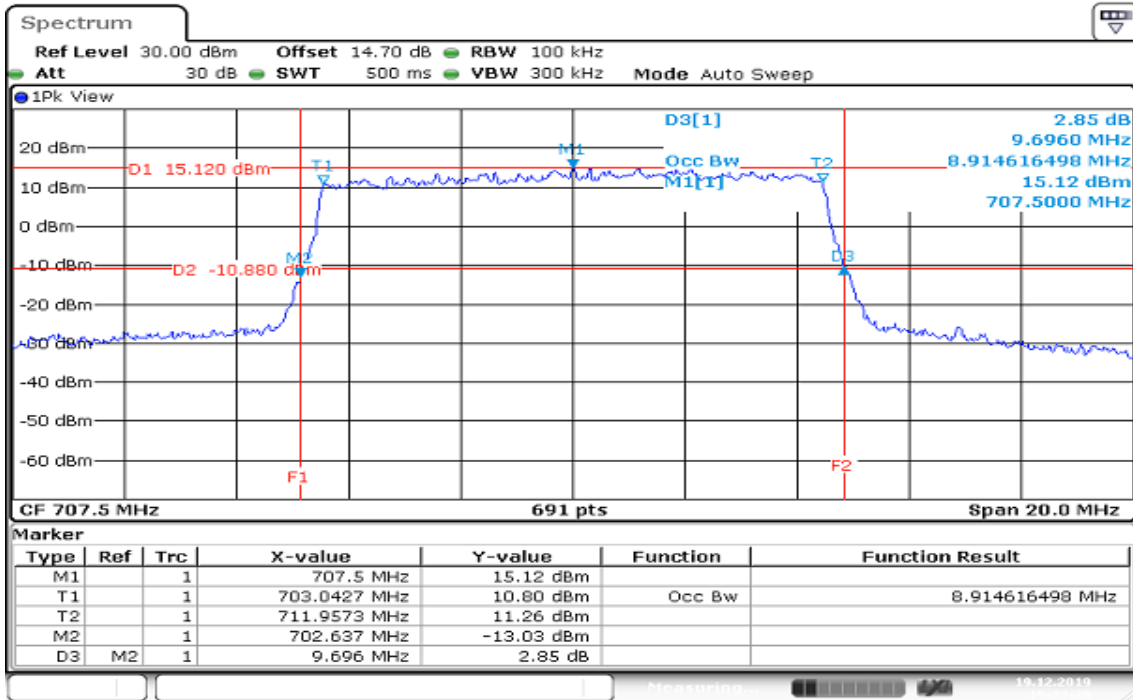

Date: 19.DEC.2019 15:23:20

CHANNEL BANDWIDTH: 10MHz / 16QAM CH Mid

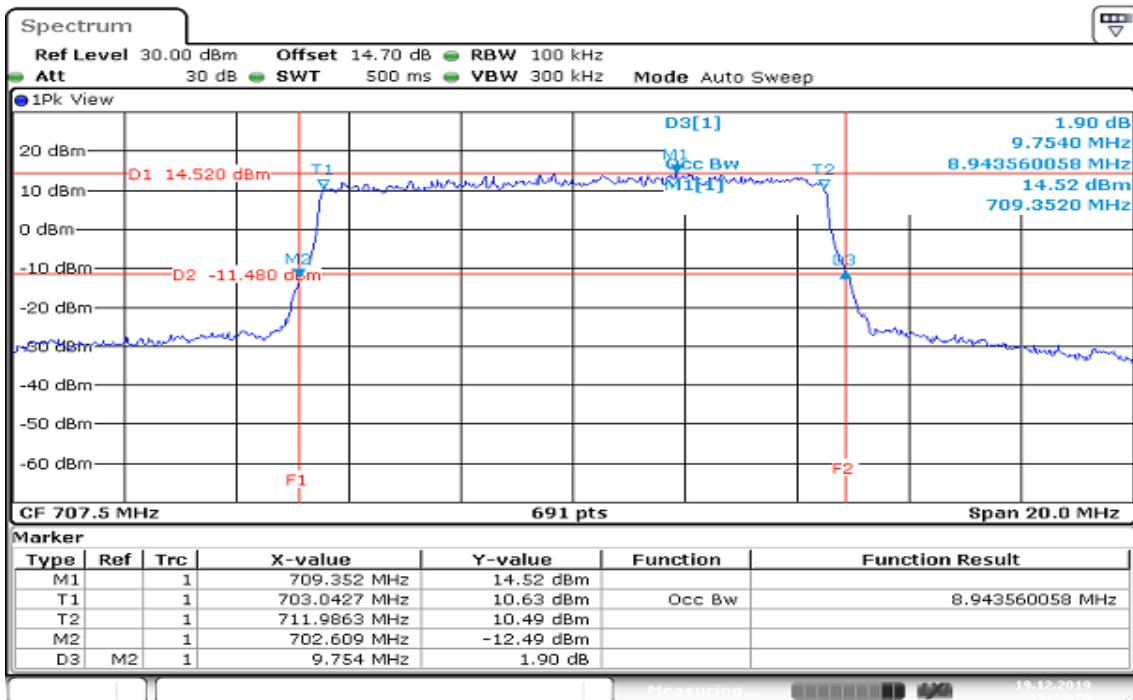

Date: 19.DEC.2019 15:24:21

8.4 PEAK TO AVERAGE POWER RATIO

LIMIT

In measuring transmissions in this band using an average power technique, peak-to-average power ratio (PAPR) of the transmission may not exceed 13 dB.

TEST PROCEDURES

1. According to KDB 971168D01.
2. The EUT was connect to spectrum analyzer and call box.
3. Set the CCDF function in spectrum analyzer.
4. The highest RF output power were measured and recorded the maximum PAPR level associated with a probability of 0.1%.
5. Record the Peak to Average Power Ratio.

Report No.: T191120D05-RP8

TEST RESULTS

LTE Band 12

CHANNEL BANDWIDTH: 1.4MHz / QPSK / 1RB

Channel	FREQUENCY (MHz)	PEAK TO AVERAGE RATIO (dB)
20175	707.5	4.78

CHANNEL BANDWIDTH: 3MHz / QPSK / 1RB

Channel	FREQUENCY (MHz)	PEAK TO AVERAGE RATIO (dB)
23095	707.5	4.87

CHANNEL BANDWIDTH: 5MHz / QPSK / 1RB

Channel	FREQUENCY (MHz)	PEAK TO AVERAGE RATIO (dB)
23095	707.5	4.87

CHANNEL BANDWIDTH: 10MHz / QPSK / 1RB

Channel	FREQUENCY (MHz)	PEAK TO AVERAGE RATIO (dB)
23095	707.5	4.96

CHANNEL BANDWIDTH: 1.4MHz / QPSK / FULL RB

Channel	FREQUENCY (MHz)	PEAK TO AVERAGE RATIO (dB)
23095	707.5	5.48

CHANNEL BANDWIDTH: 3MHz / QPSK / FULL RB

Channel	FREQUENCY (MHz)	PEAK TO AVERAGE RATIO (dB)
23095	707.5	5.13

CHANNEL BANDWIDTH: 5MHz / QPSK / FULL RB

Channel	FREQUENCY (MHz)	PEAK TO AVERAGE RATIO (dB)
23095	707.5	5.10

CHANNEL BANDWIDTH: 10MHz / QPSK / FULL RB

Channel	FREQUENCY (MHz)	PEAK TO AVERAGE RATIO (dB)
23095	707.5	4.99

Note: We selected worst case to performed test in middle channel, the results can be meet other channel.

CHANNEL BANDWIDTH: 1.4MHz / 16QAM / 1RB

Channel	FREQUENCY (MHz)	PEAK TO AVERAGE RATIO (dB)
23095	707.5	5.71

CHANNEL BANDWIDTH: 3MHz / 16QAM / 1RB

Channel	FREQUENCY (MHz)	PEAK TO AVERAGE RATIO (dB)
23095	707.5	5.54

CHANNEL BANDWIDTH: 5MHz / 16QAM / 1RB

Channel	FREQUENCY (MHz)	PEAK TO AVERAGE RATIO (dB)
23095	707.5	5.97

CHANNEL BANDWIDTH: 10MHz / 16QAM / 1RB

Channel	FREQUENCY (MHz)	PEAK TO AVERAGE RATIO (dB)
23095	707.5	5.59

CHANNEL BANDWIDTH: 1.4MHz / 16QAM / FULL RB

Channel	FREQUENCY (MHz)	PEAK TO AVERAGE RATIO (dB)
23095	707.5	6.23

CHANNEL BANDWIDTH: 3MHz / 16QAM / FULL RB

Channel	FREQUENCY (MHz)	PEAK TO AVERAGE RATIO (dB)
23095	707.5	6.12

CHANNEL BANDWIDTH: 5MHz / 16QAM / FULL RB

Channel	FREQUENCY (MHz)	PEAK TO AVERAGE RATIO (dB)
23095	707.5	6.12

CHANNEL BANDWIDTH: 10MHz / 16QAM / FULL RB

Channel	FREQUENCY (MHz)	PEAK TO AVERAGE RATIO (dB)
23095	707.5	6.12

Note: We selected worst case to performed test in middle channel, the results can be meet other channel.

LTE Band 12

CHANNEL BANDWIDTH: 1.4MHz / QPSK/1RB

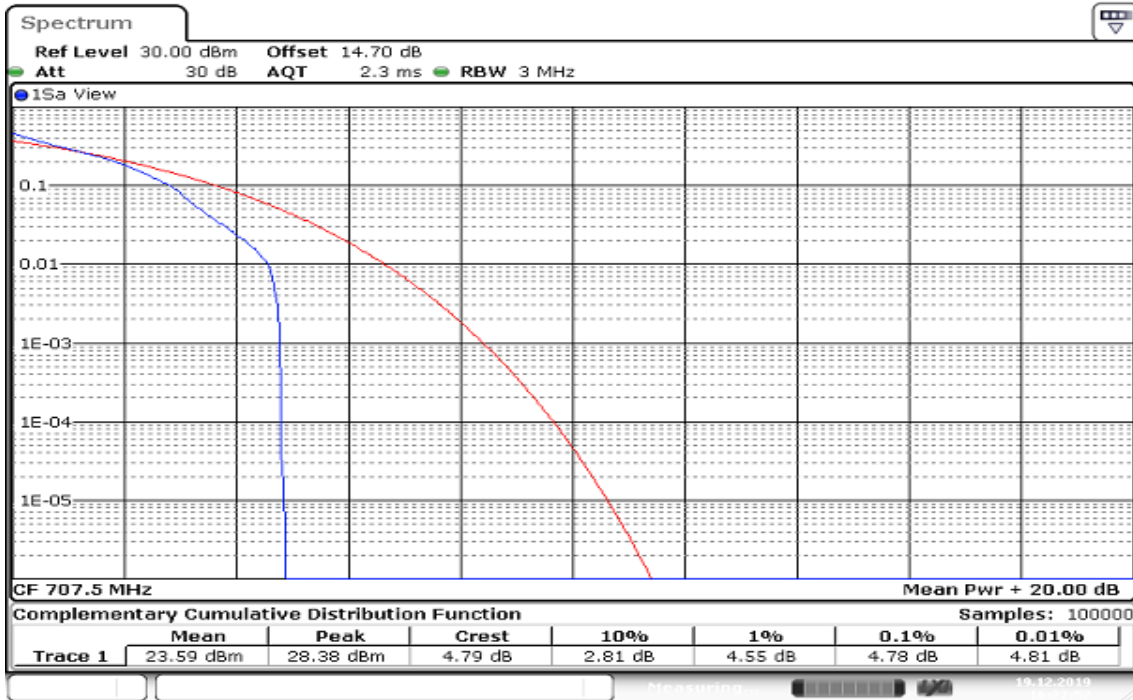

Date: 19.DEC.2019 16:27:52

CHANNEL BANDWIDTH: 3MHz / QPSK /1RB

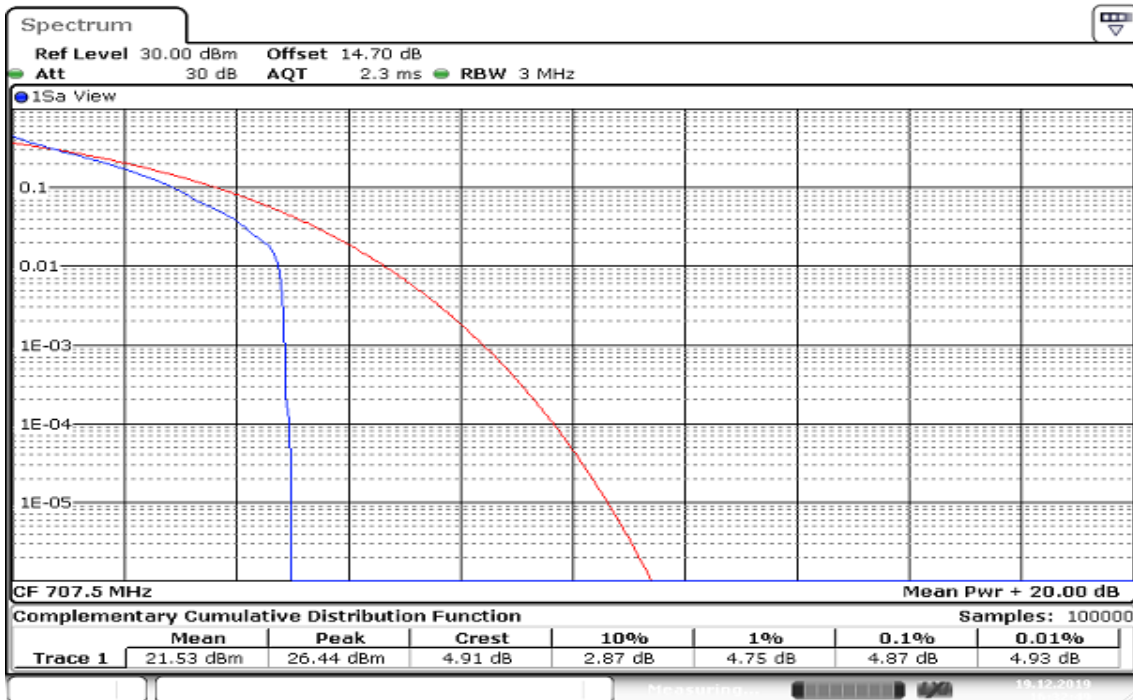

Date: 19.DEC.2019 16:32:50

CHANNEL BANDWIDTH: 5MHz / QPSK/1RB

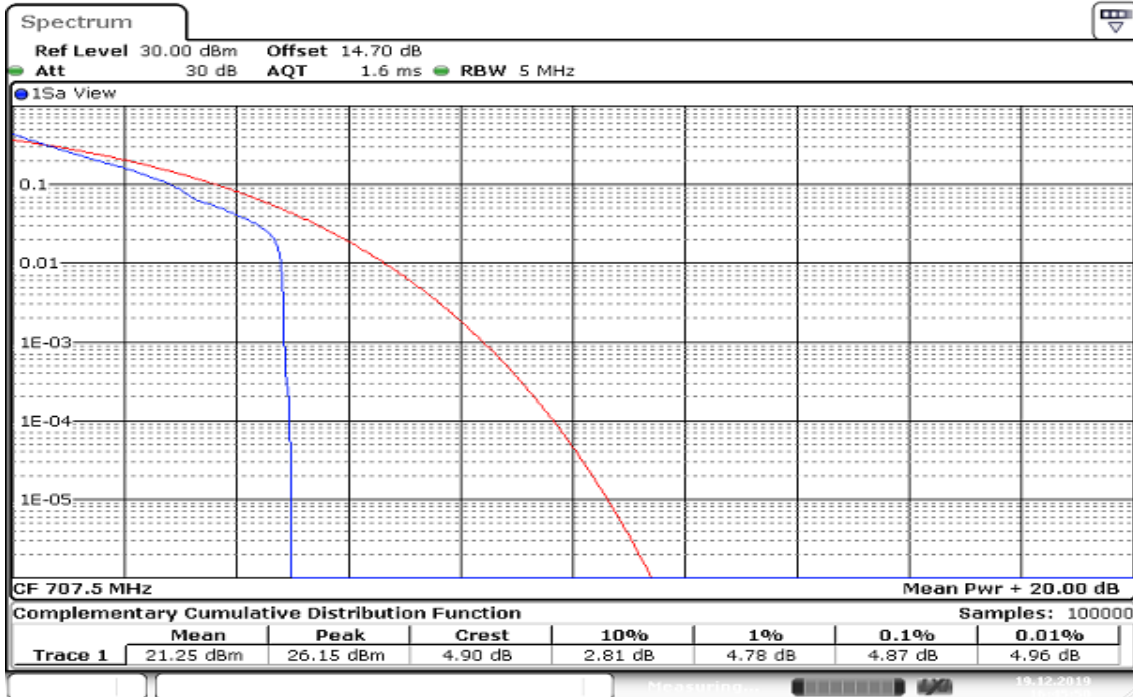

Date: 19.DEC.2019 16:45:51

CHANNEL BANDWIDTH: 10MHz / QPSK/1RB

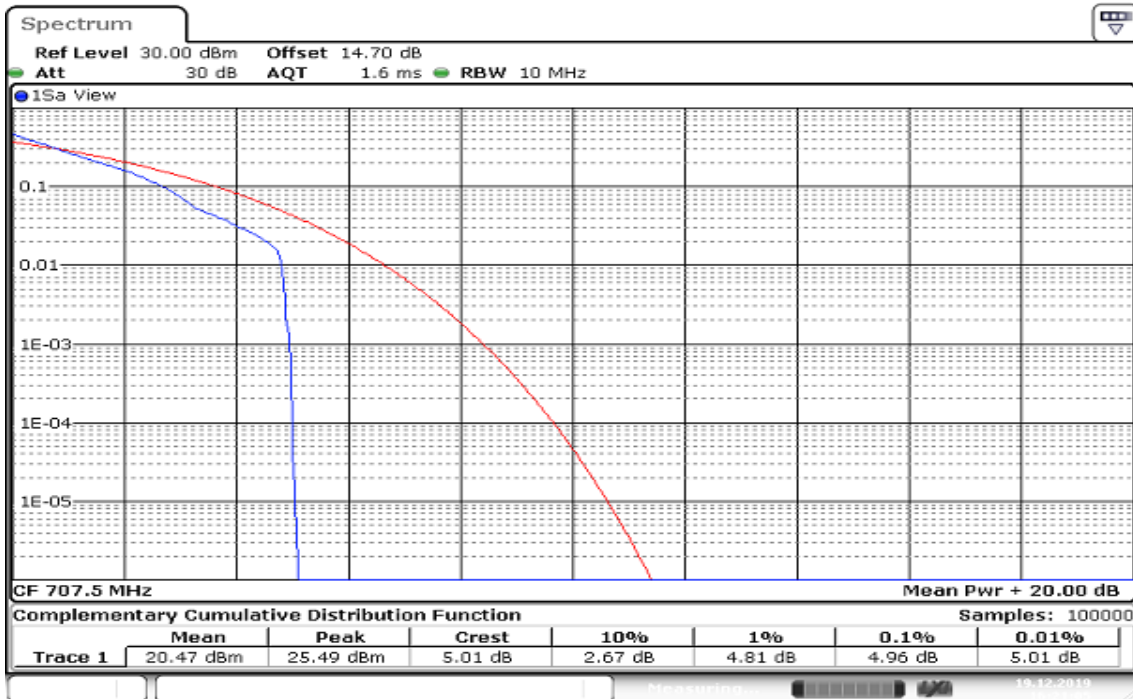

Date: 19.DEC.2019 16:21:05

CHANNEL BANDWIDTH: 1.4MHz / QPSK/ FULL RB

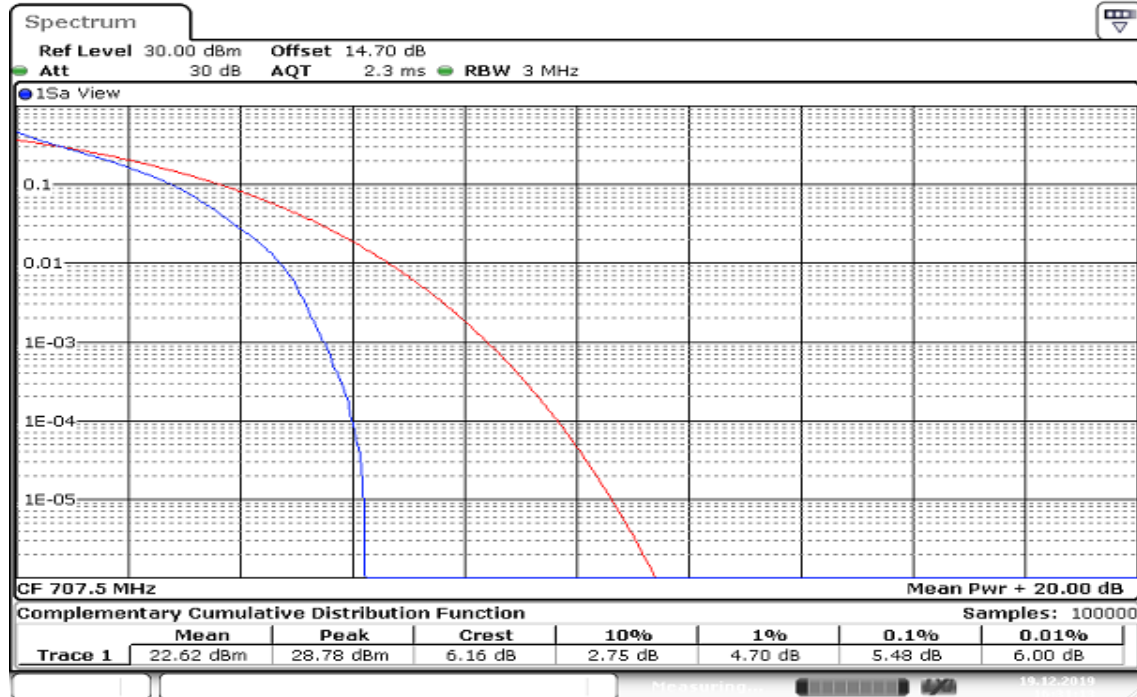

Date: 19.DEC.2019 16:31:14

CHANNEL BANDWIDTH: 3MHz / QPSK / FULL RB

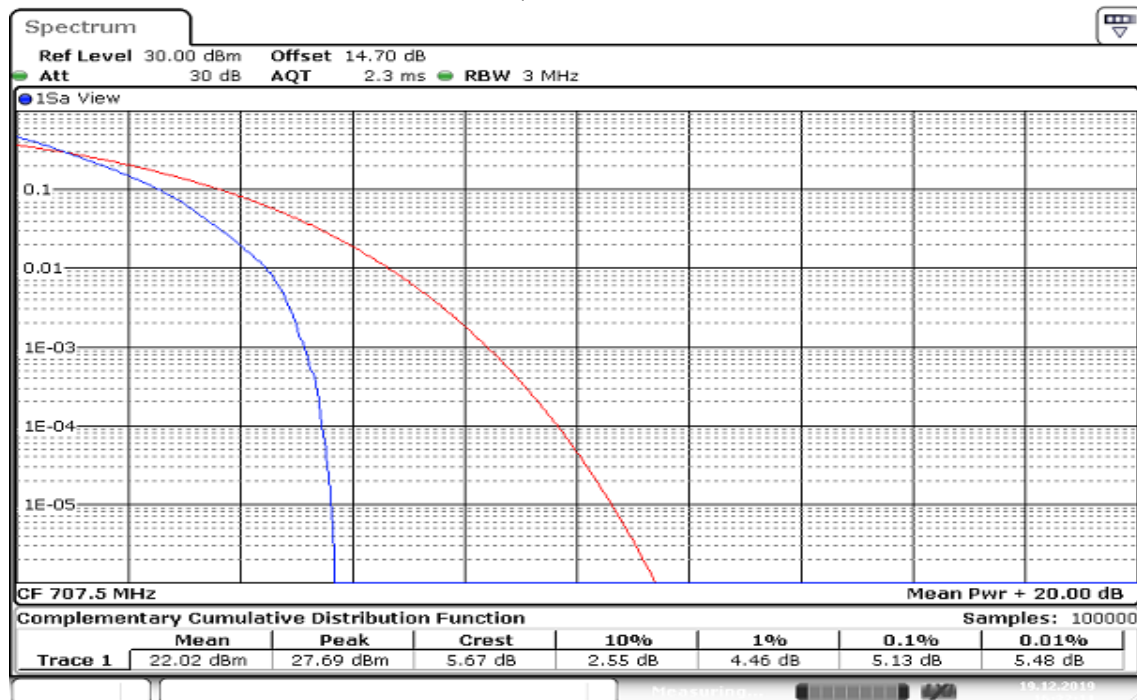

Date: 19.DEC.2019 16:32:11

CHANNEL BANDWIDTH: 5MHz / QPSK / FULL RB

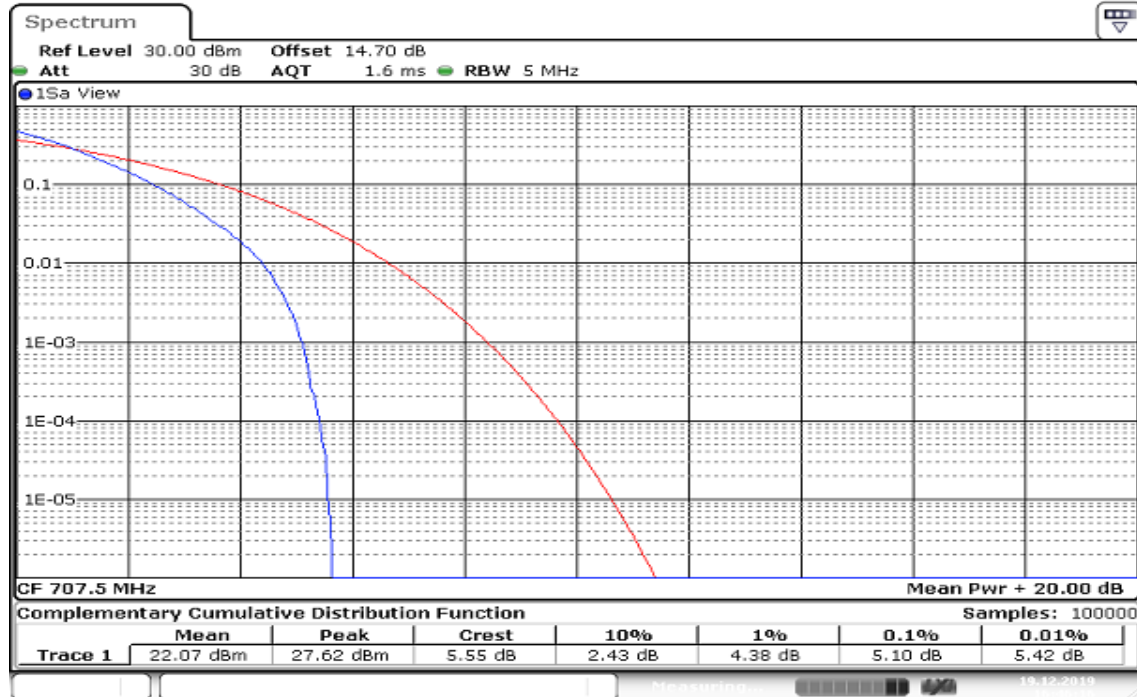

Date: 19.DEC.2019 16:46:16

CHANNEL BANDWIDTH: 10MHz / QPSK / FULL RB

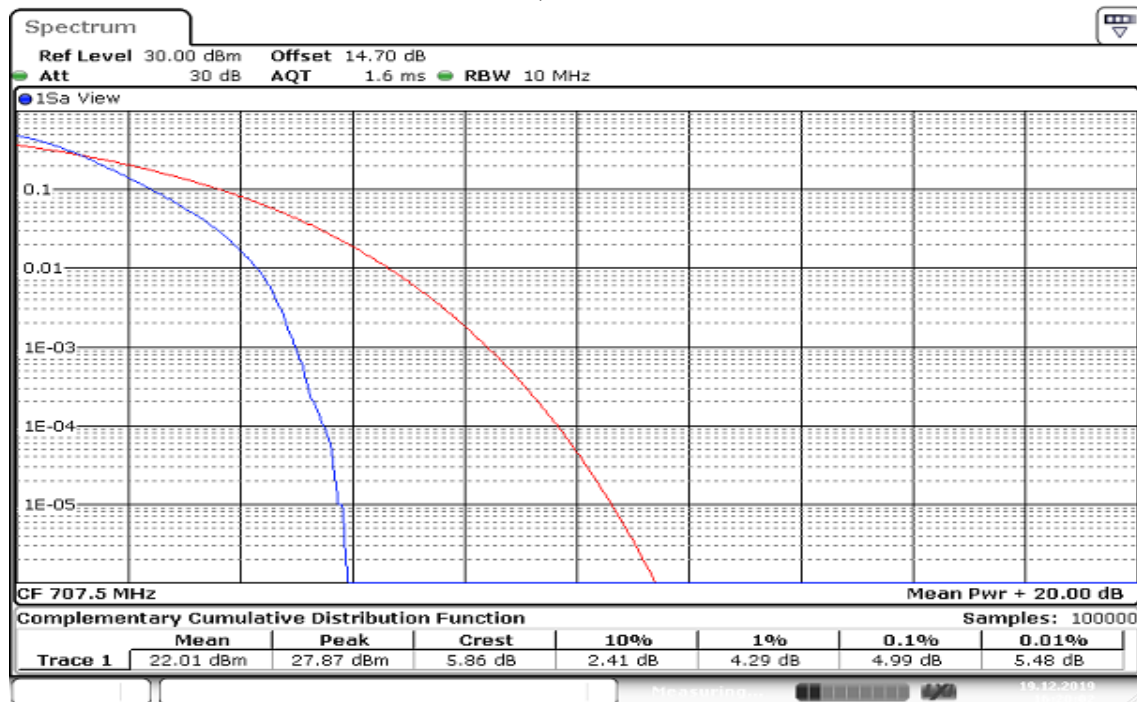

Date: 19.DEC.2019 16:20:02

CHANNEL BANDWIDTH: 1.4MHz / 16QAM / 1RB

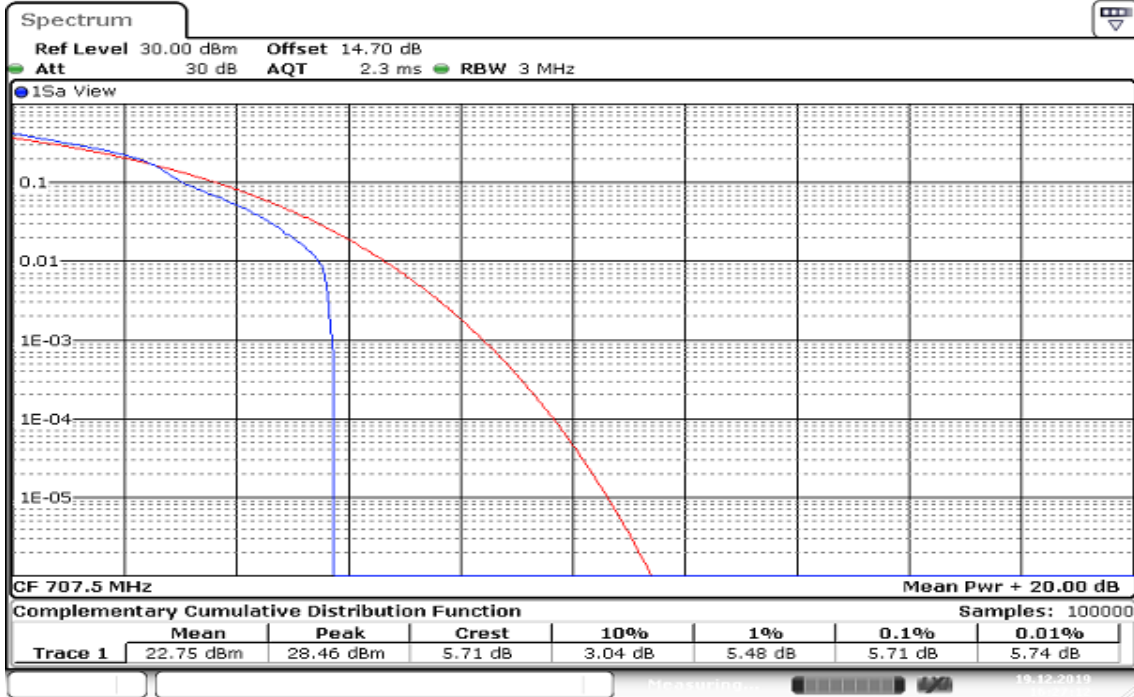

Date: 19.DEC.2019 16:27:13

CHANNEL BANDWIDTH: 3MHz / 16QAM / 1RB

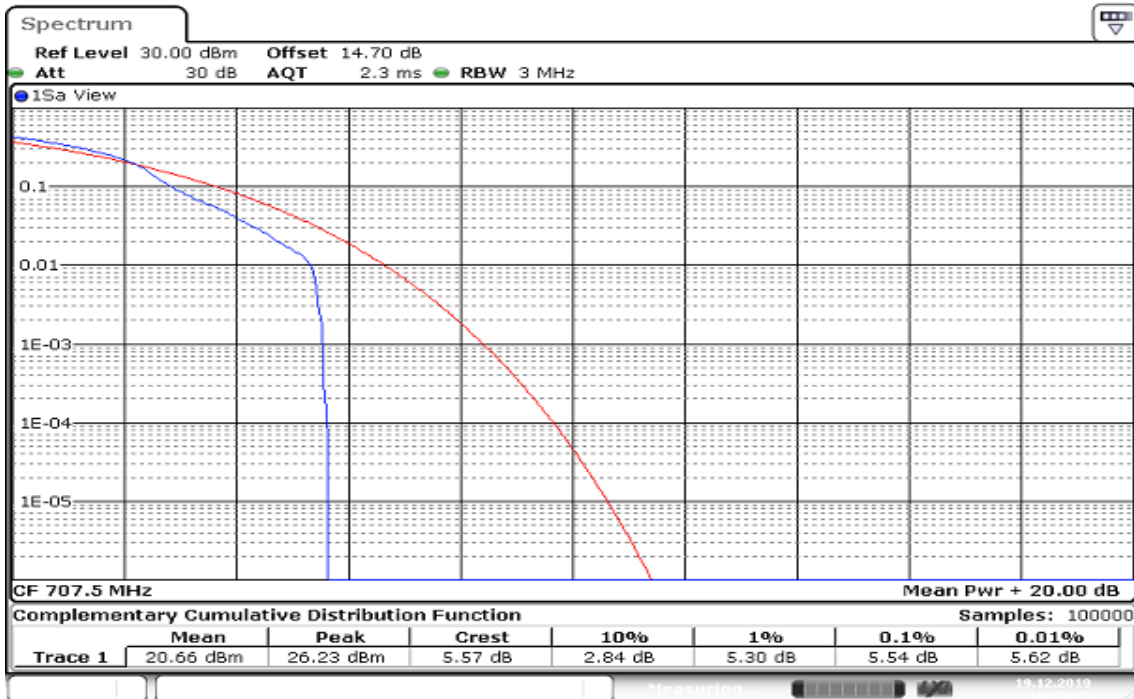

Date: 19.DEC.2019 16:39:16

CHANNEL BANDWIDTH: 5MHz / 16QAM /1RB

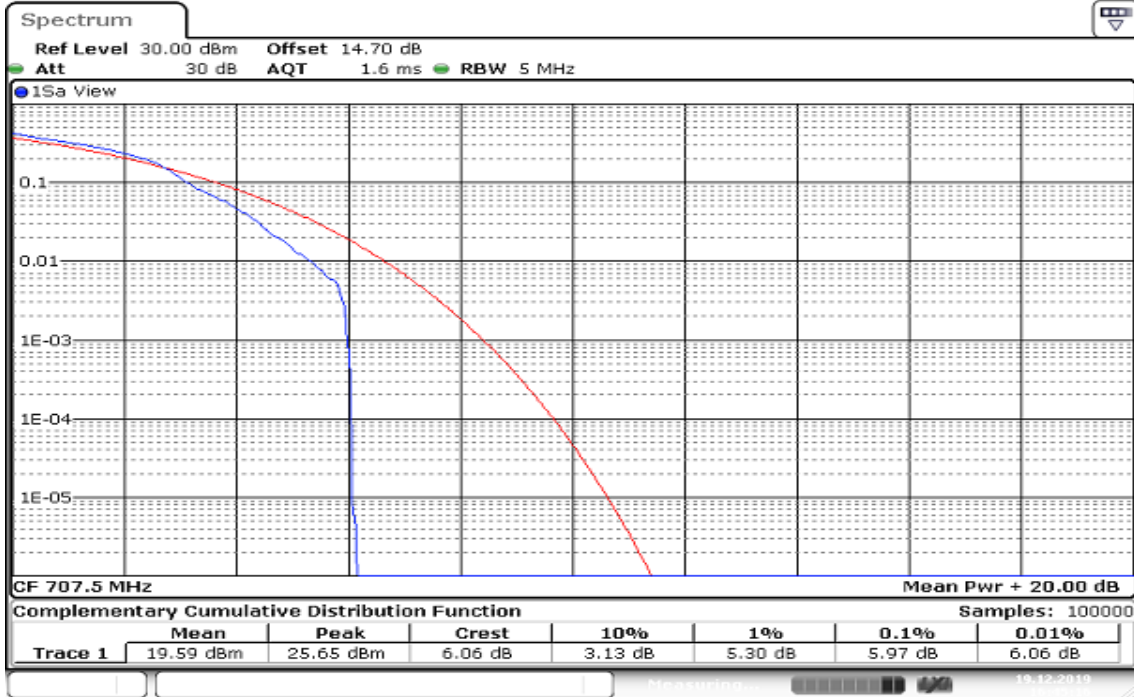

Date: 19.DEC.2019 16:45:16

CHANNEL BANDWIDTH: 10MHz / 16QAM /1RB

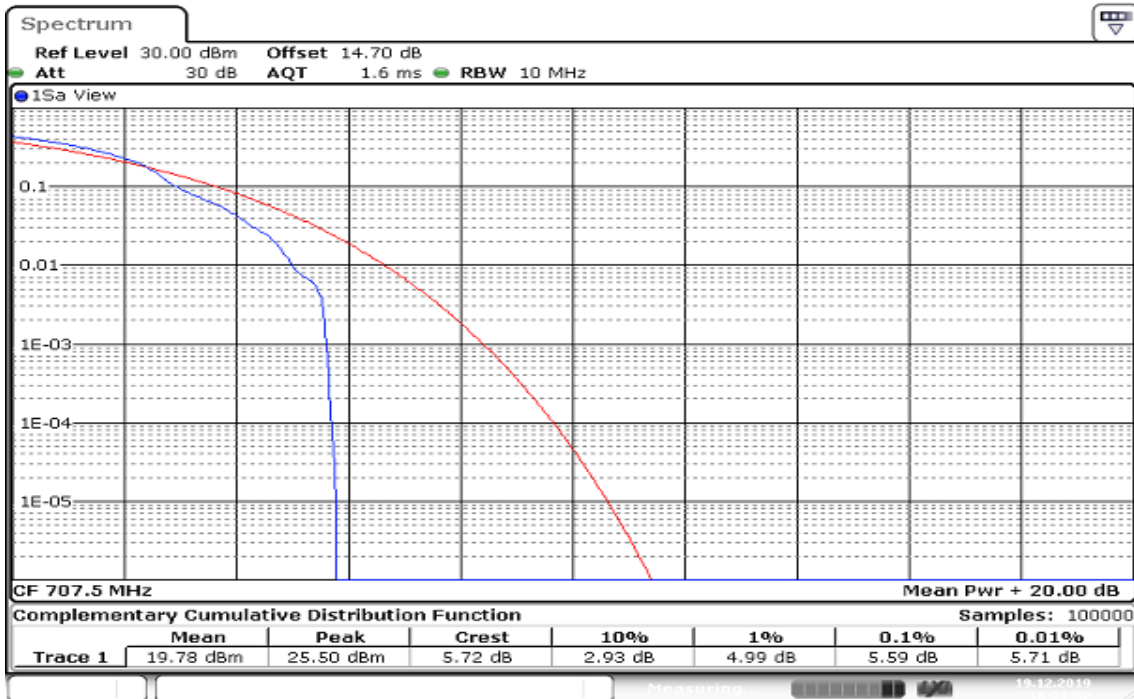

Date: 19.DEC.2019 16:21:52

CHANNEL BANDWIDTH: 1.4MHz / 16QAM / FULL RB

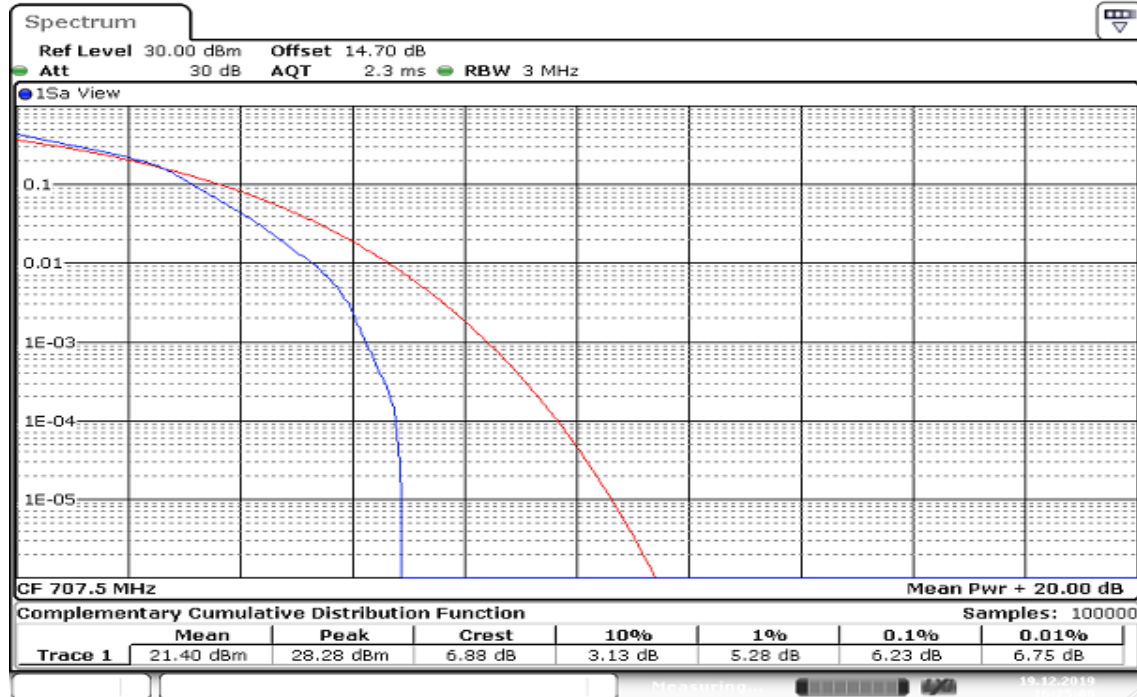

Date: 19.DEC.2019 16:25:00

CHANNEL BANDWIDTH: 3MHz / 16QAM / FULL RB

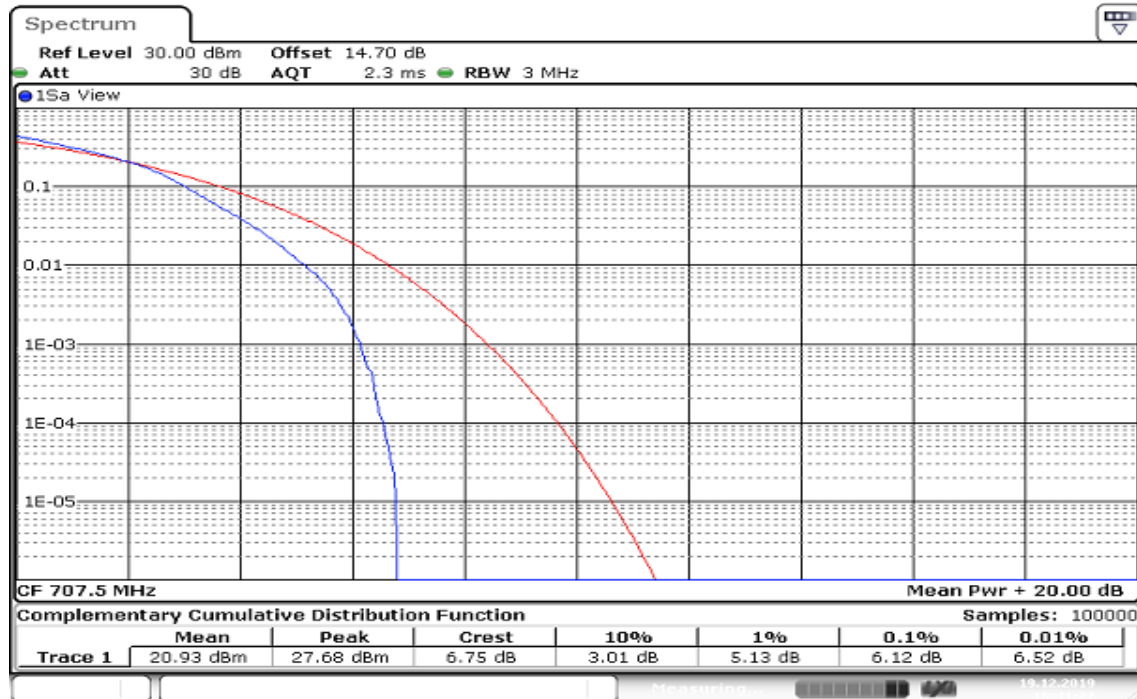

Date: 19.DEC.2019 16:41:27

CHANNEL BANDWIDTH: 5MHz / 16QAM / FULL RB

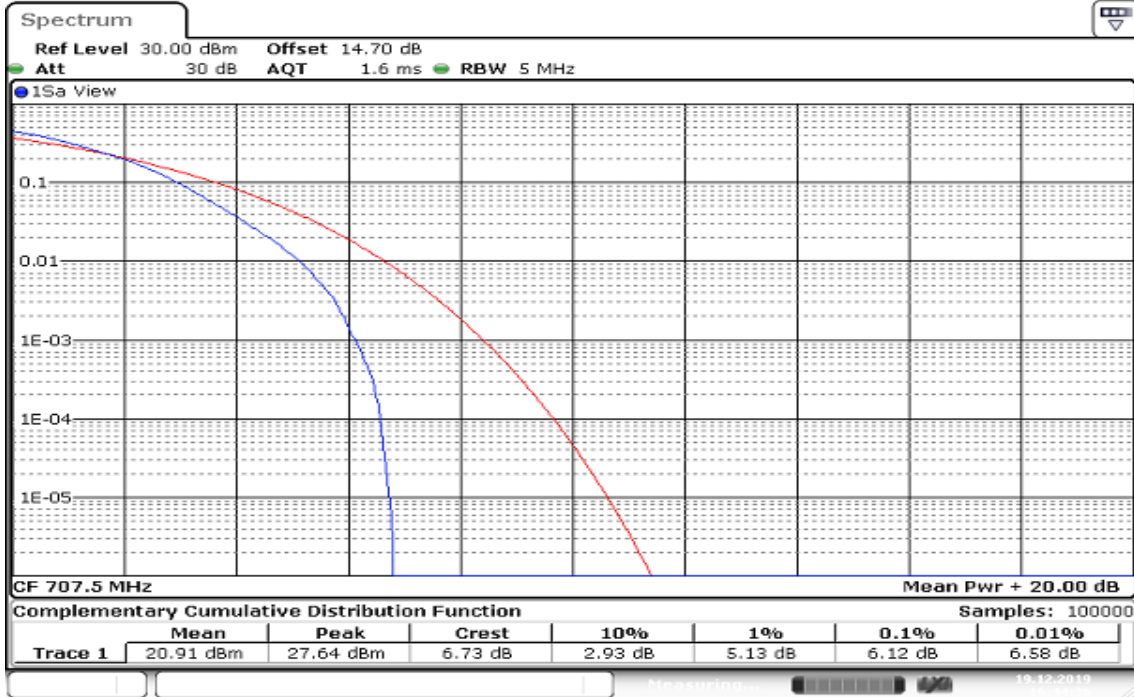

Date: 19.DEC.2019 16:44:37

CHANNEL BANDWIDTH: 10MHz / 16QAM / FULL RB

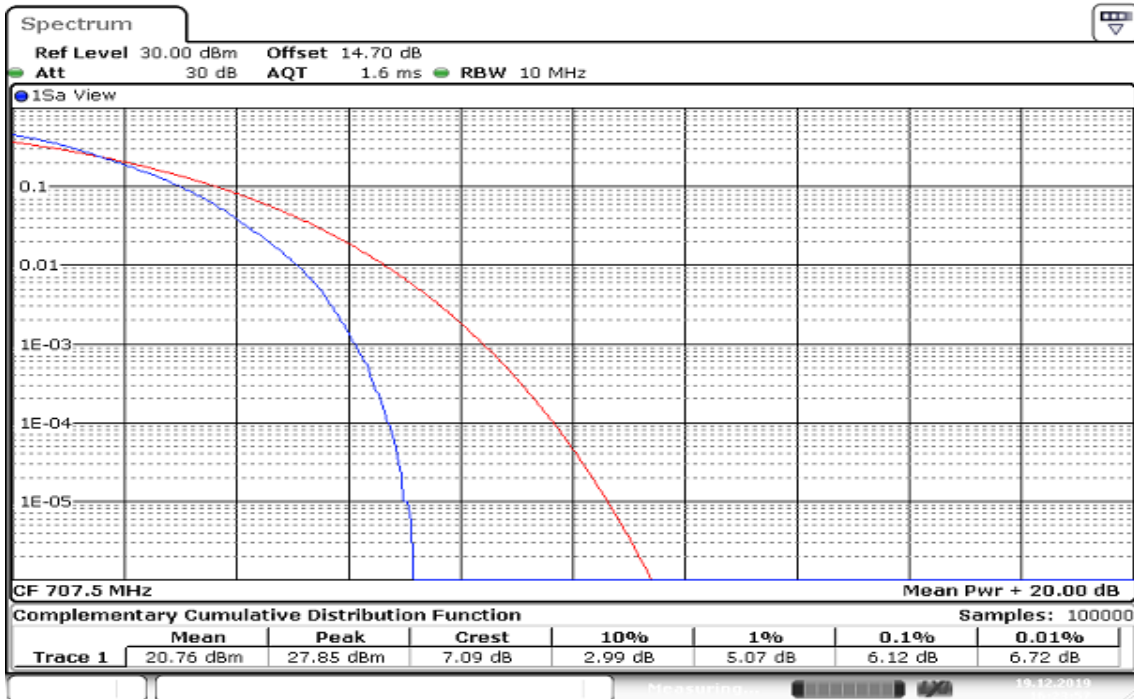

Date: 19.DEC.2019 16:23:58

8.5 BAND EDGE MEASUREMENT

LIMIT

Part 27.53 (g), Band 12

For operations in the 600 MHz band and the 698-746 MHz band, the power of any emission outside a licensee's frequency band(s) of operation shall be attenuated below the transmitter power (P) within the licensed band(s) of operation, measured in watts, by at least $43 + 10 \log (P)$ dB. Compliance with this provision is based on the use of measurement instrumentation employing a resolution bandwidth of 100 kilohertz or greater. However, in the 100 kilohertz bands immediately outside and adjacent to a licensee's frequency block, a resolution bandwidth of at least 30 kHz may be employed.

According to RSS-130, Band 12

The power of any unwanted emissions in any 100 kHz bandwidth on any frequency outside the frequency range(s) within which the equipment is designed to operate shall be attenuated below the transmitter power, P (dBW), by at least $43 + 10 \log_{10} p$ (watts), dB. However, in the 100 kHz band immediately outside the equipment's operating frequency range, a resolution bandwidth of 30 kHz may be employed.

TEST PROCEDURES

KDB 971168 D01 Power Meas License Digital Systems – Section 6.0

1. RBW \geq 1% of the emission bandwidth
2. VBW \geq 3 x RBW
3. Span was set large enough so as to capture all out of emissions near the band edge.

Report No.: T191120D05-RP8

TEST RESULTS:

LTE Band 12

CHANNEL BANDWIDTH: 1.4MHz / QPSK / 1RB ALLOCATION

LOWER BAND EDGE

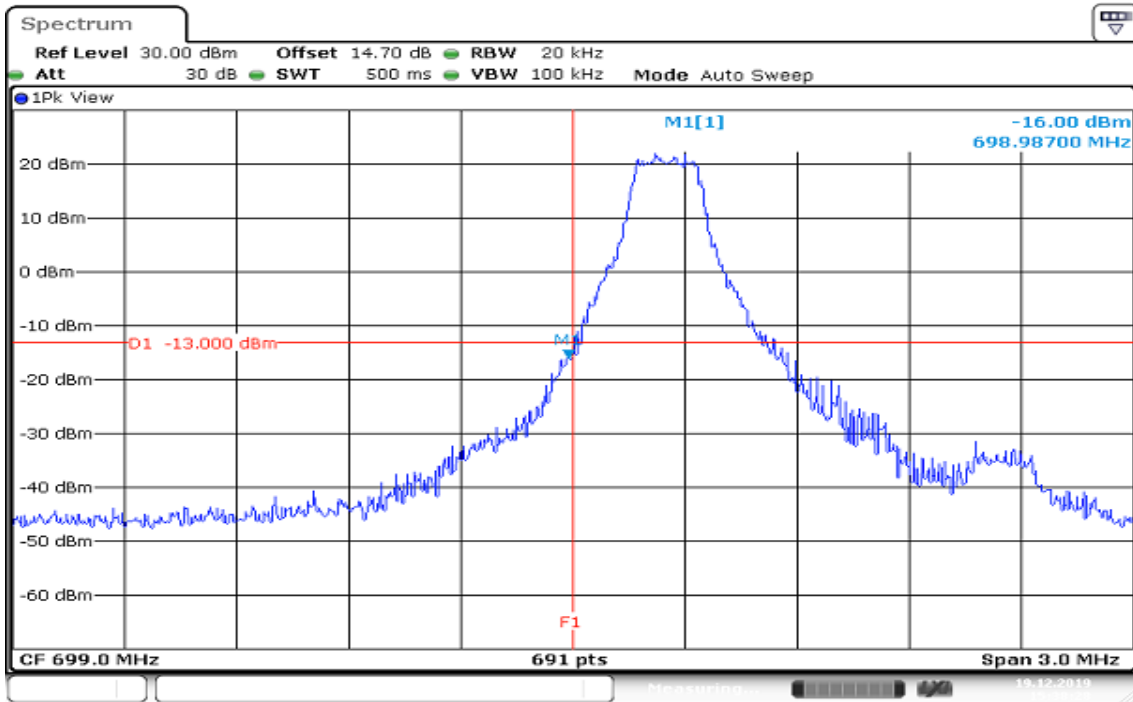

HIGHER BAND EDGE

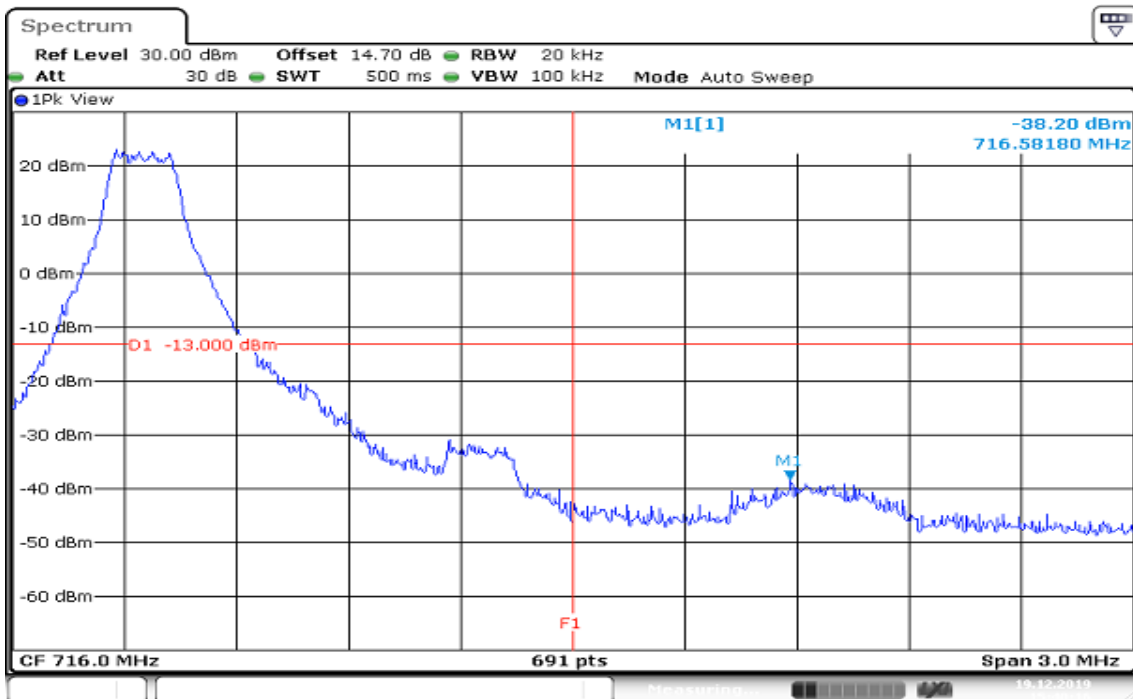

Report No.: T191120D05-RP8

CHANNEL BANDWIDTH: 3MHz / QPSK / 1RB ALLOCATION LOWER BAND EDGE

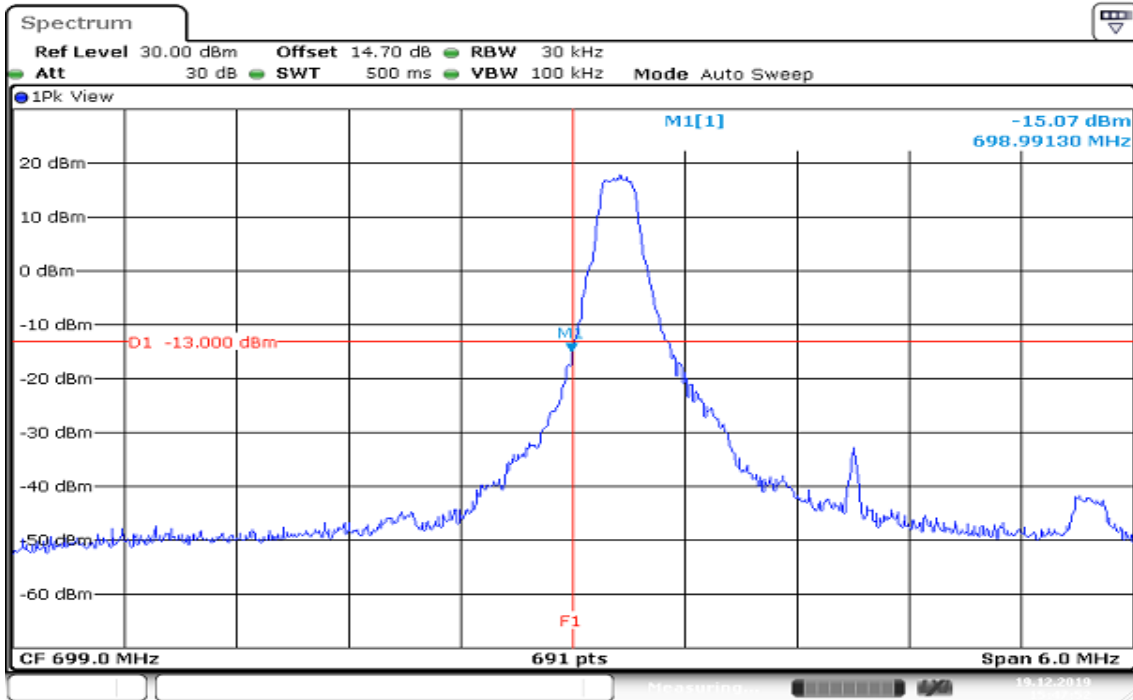

Date: 19.DEC.2019 15:47:52

HIGHER BAND EDGE

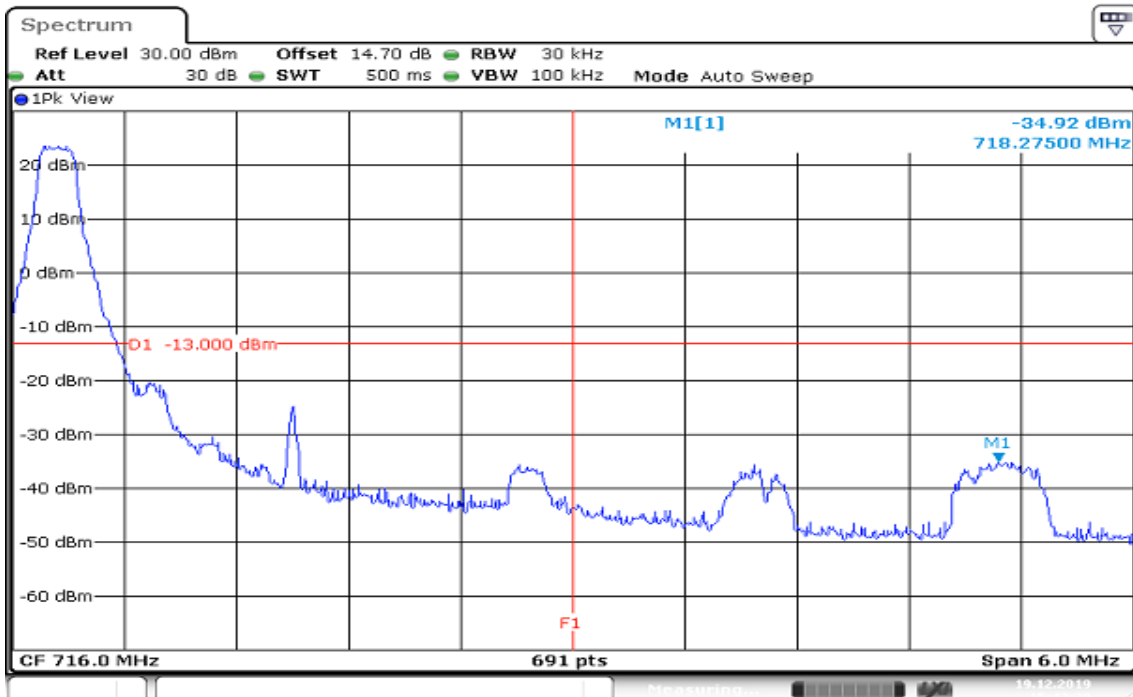

Date: 19.DEC.2019 15:43:29

Report No.: T191120D05-RP8

CHANNEL BANDWIDTH: 5MHz / QPSK / 1RB ALLOCATION LOWER BAND EDGE

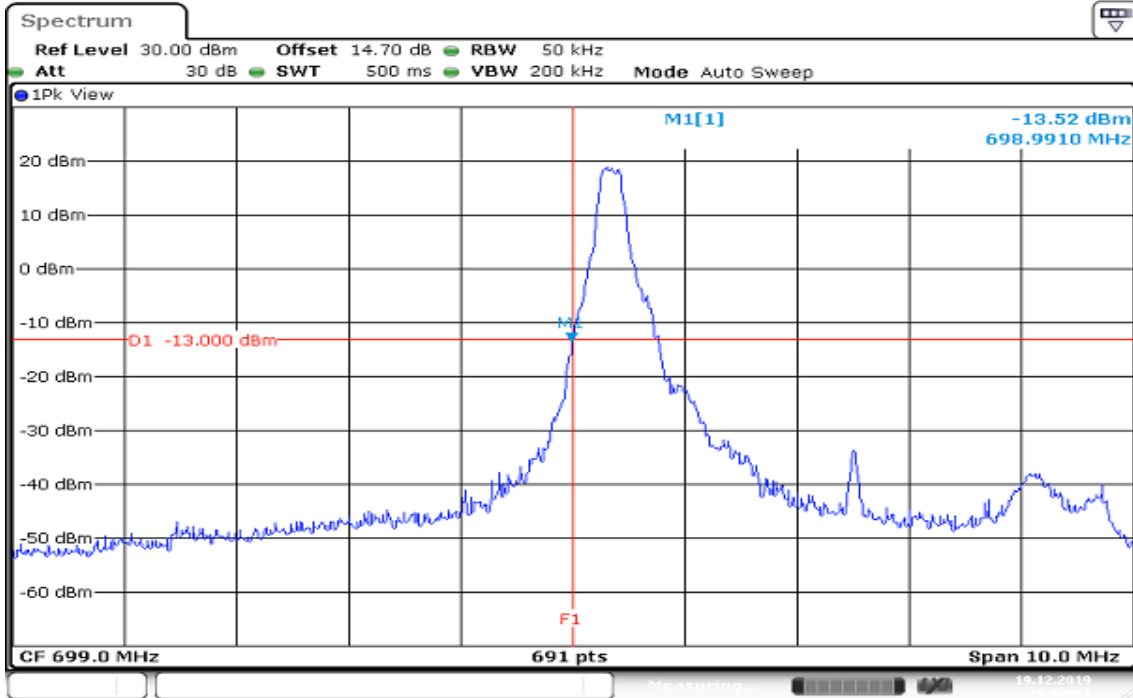

Date: 19.DEC.2019 16:02:52

HIGHER BAND EDGE

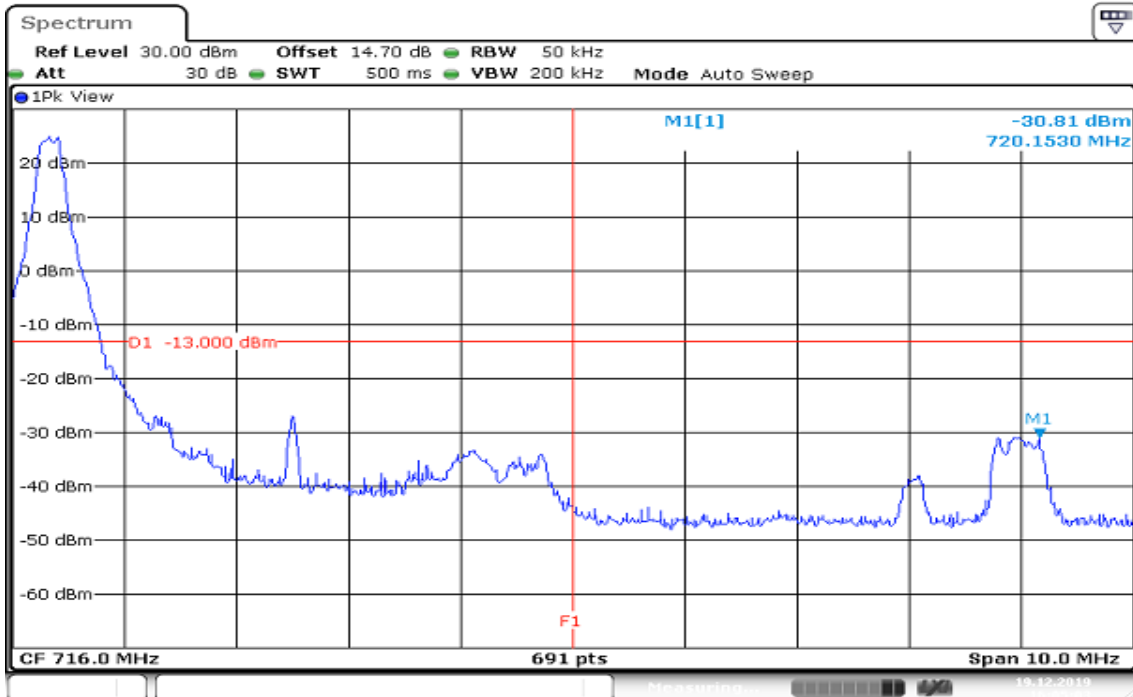

Date: 19.DEC.2019 16:05:04

Report No.: T191120D05-RP8

CHANNEL BANDWIDTH: 10MHz / QPSK / 1RB ALLOCATION LOWER BAND EDGE

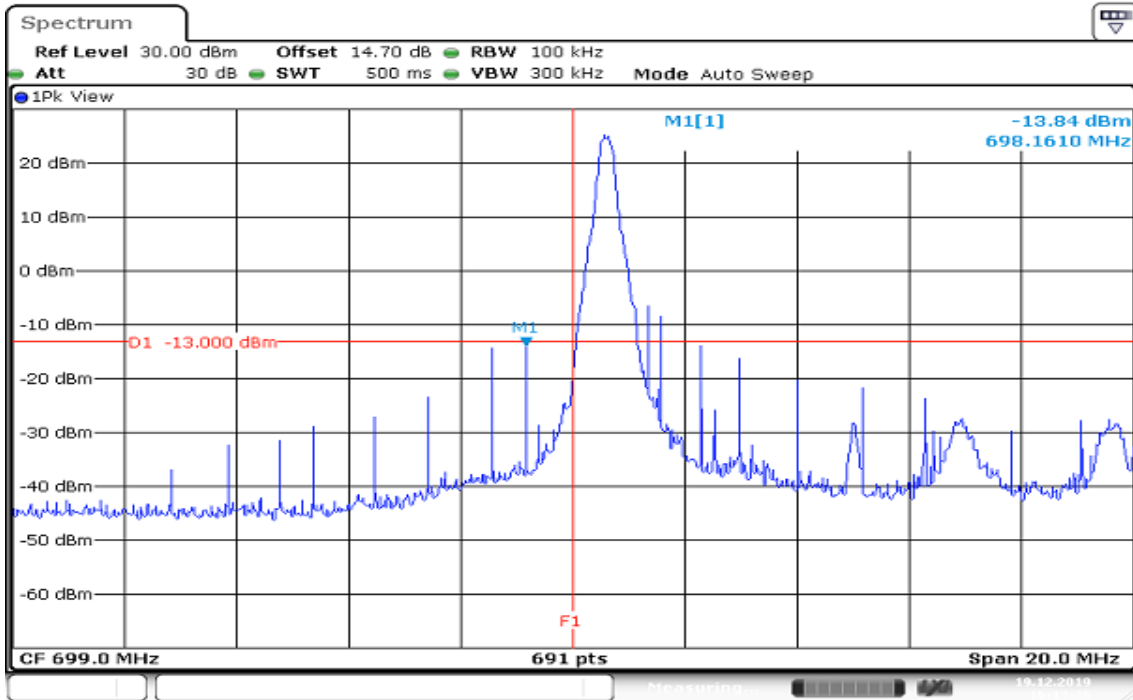

Date: 19.DEC.2019 16:13:36

HIGHER BAND EDGE

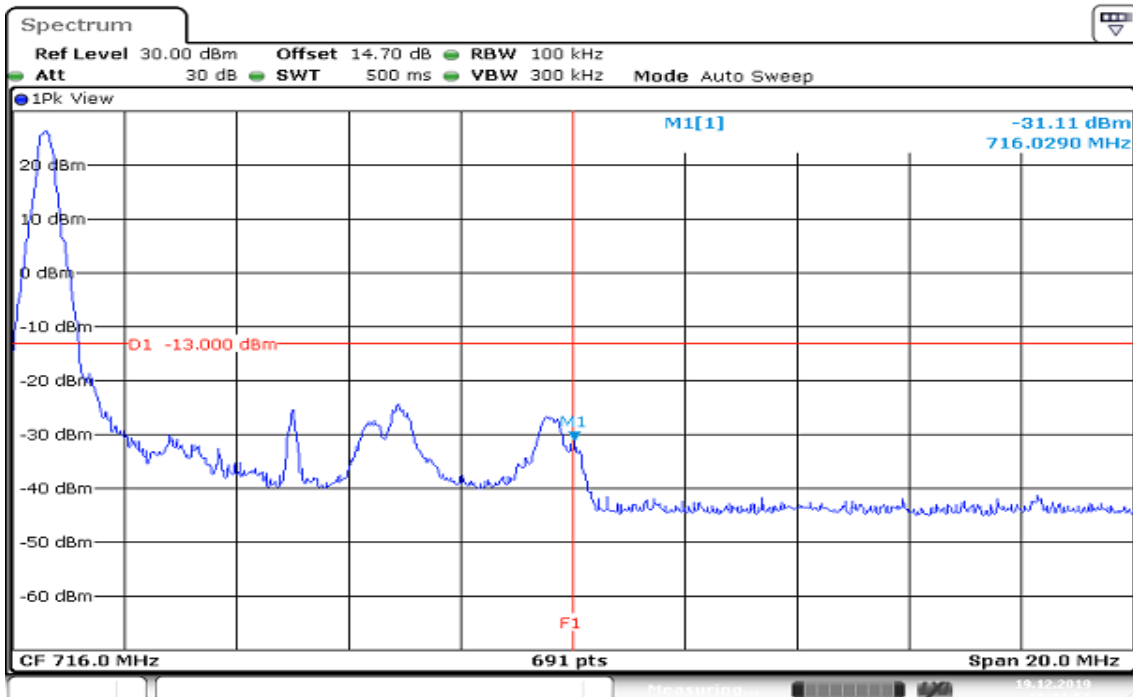

Date: 19.DEC.2019 16:11:51

CHANNEL BANDWIDTH: 1.4MHz / QPSK / FULLRB ALLOCATION LOWER BAND EDGE

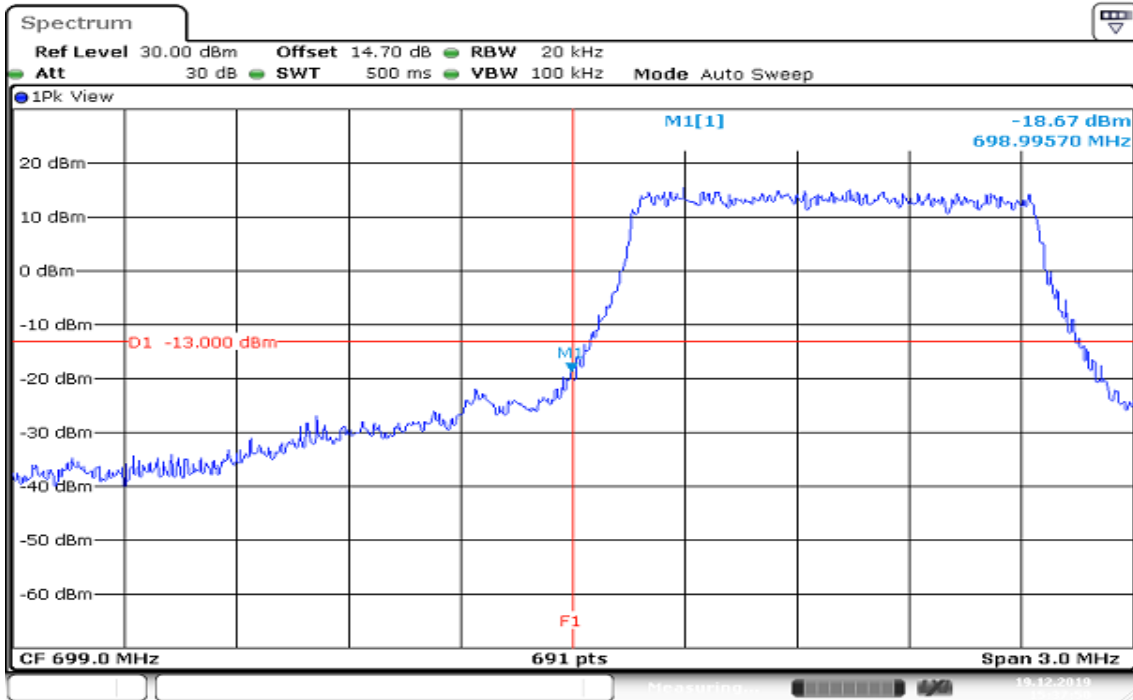

HIGHER BAND EDGE

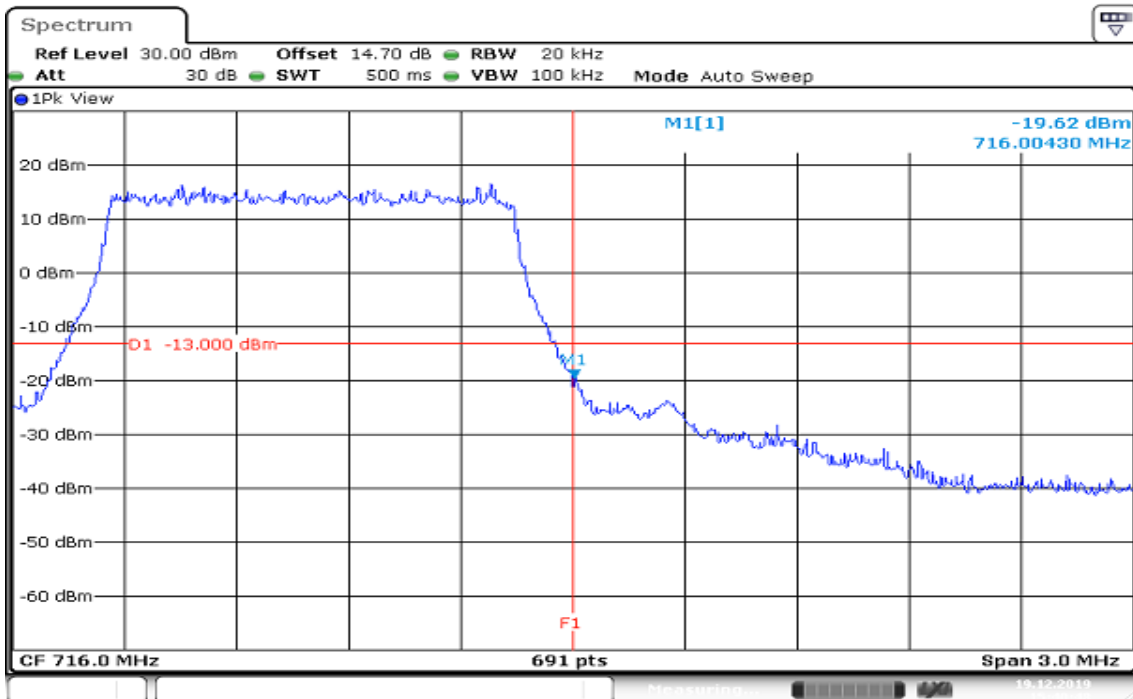

Report No.: T191120D05-RP8

CHANNEL BANDWIDTH: 3MHz / QPSK / FULLRB ALLOCATION LOWER BAND EDGE

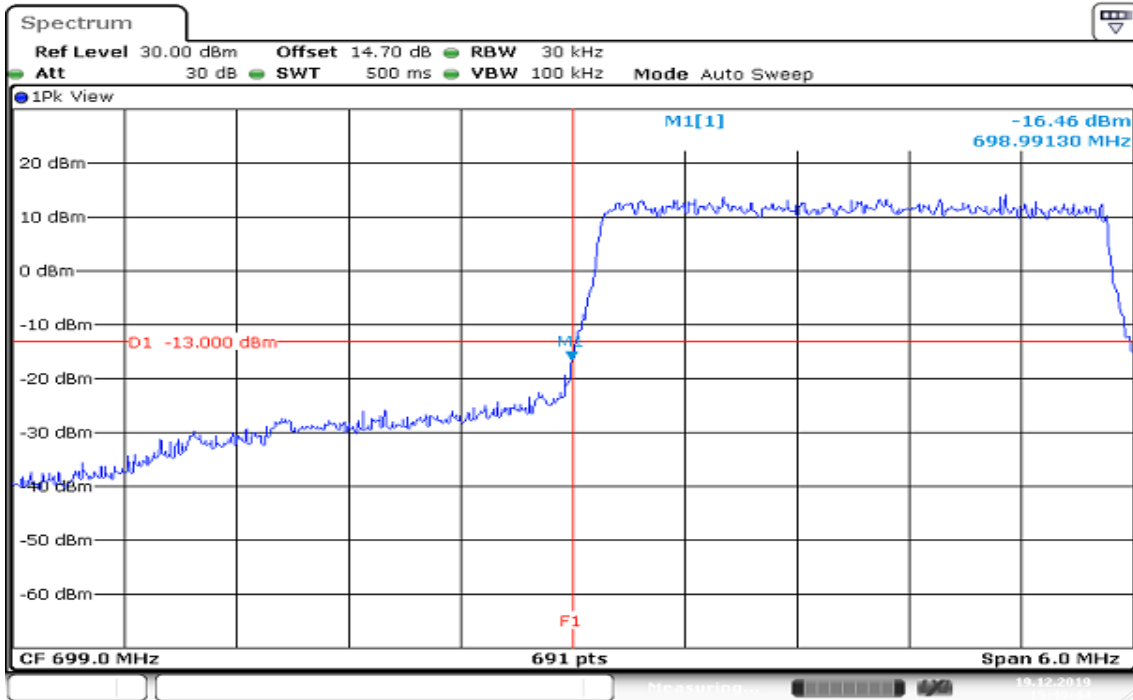

HIGHER BAND EDGE

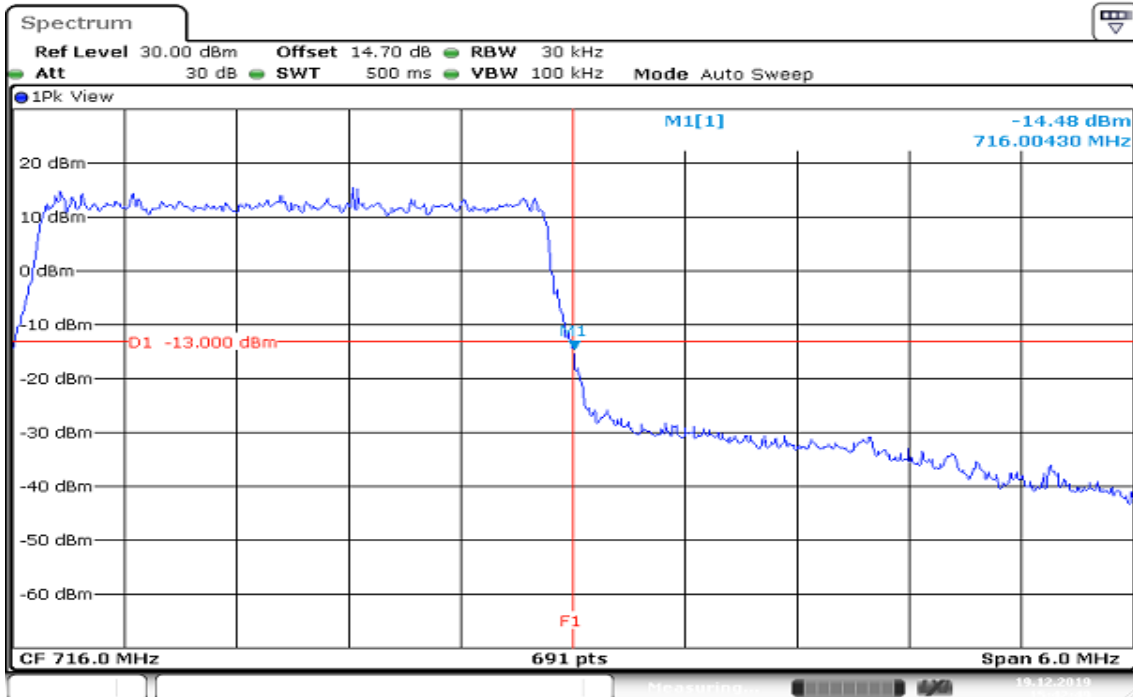

CHANNEL BANDWIDTH: 5MHz / QPSK / FULLRB ALLOCATION LOWER BAND EDGE

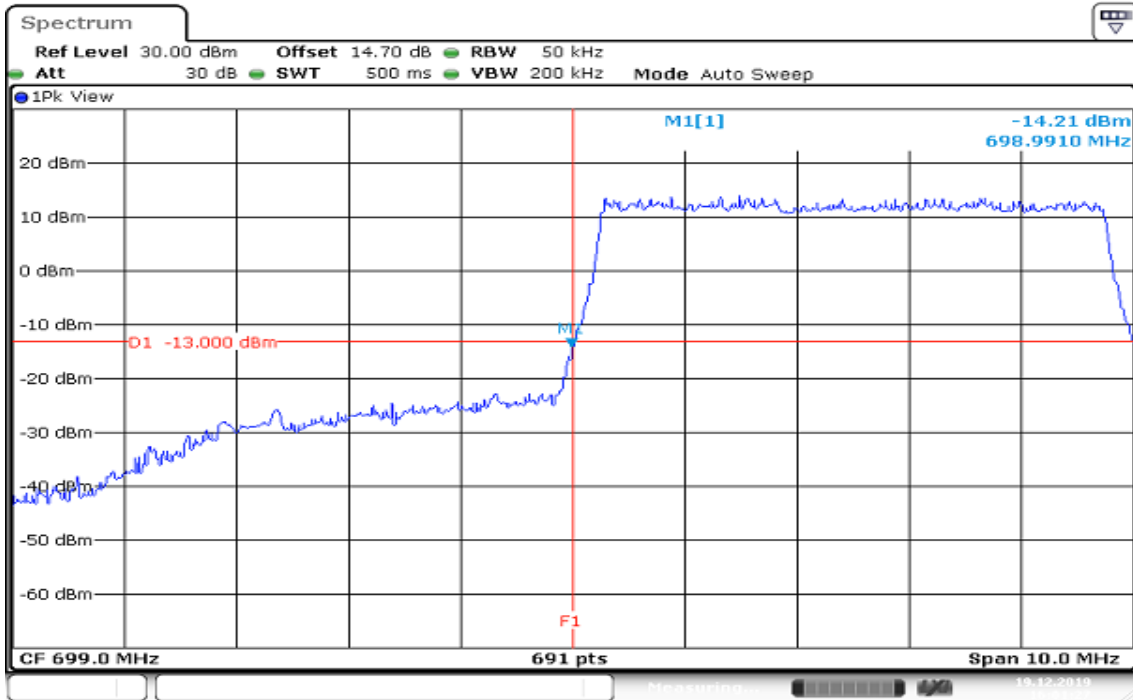

HIGHER BAND EDGE

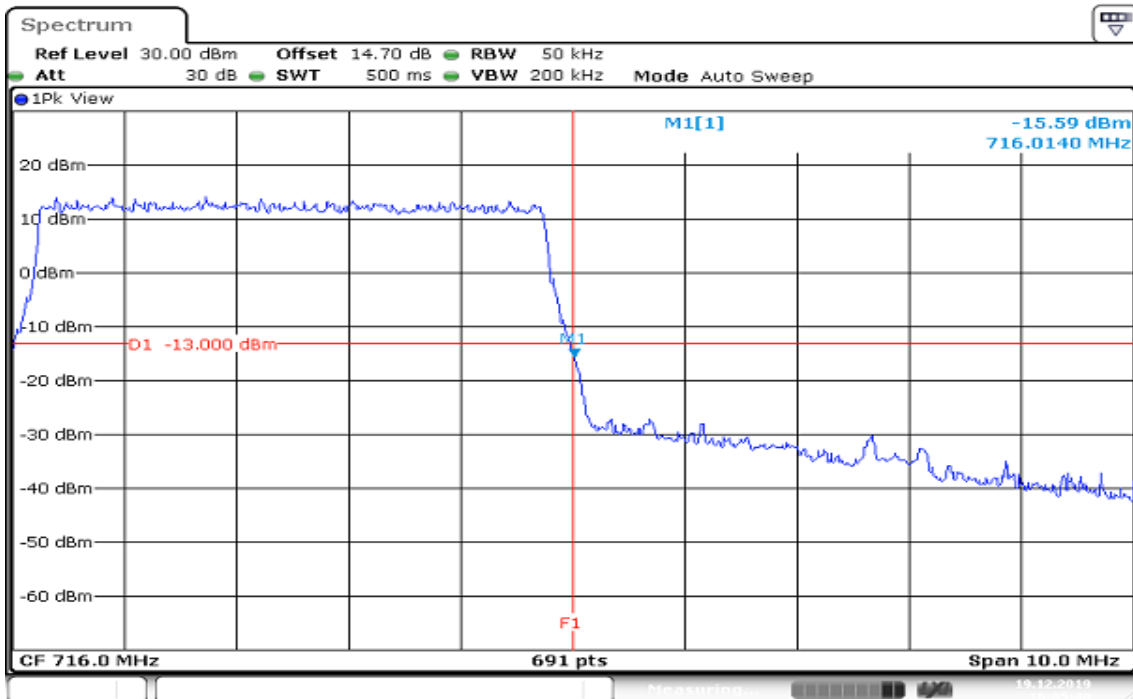

CHANNEL BANDWIDTH: 10MHz / QPSK / FULLRB ALLOCATION LOWER BAND EDGE

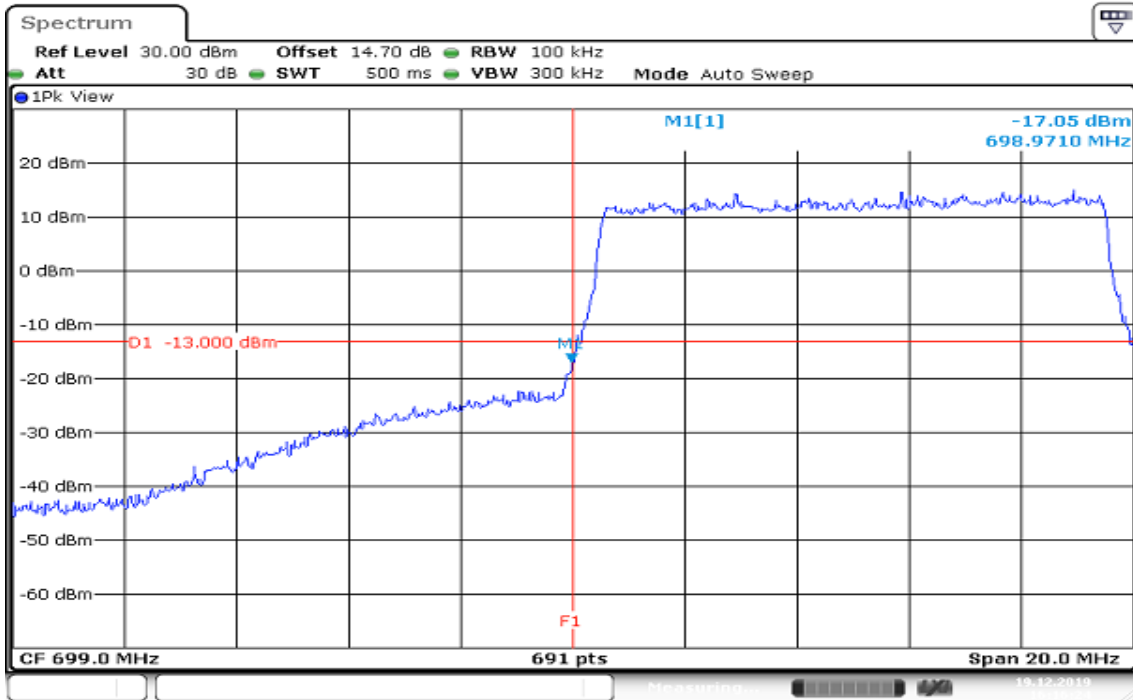

Date: 19.DEC.2019 16:16:24

HIGHER BAND EDGE

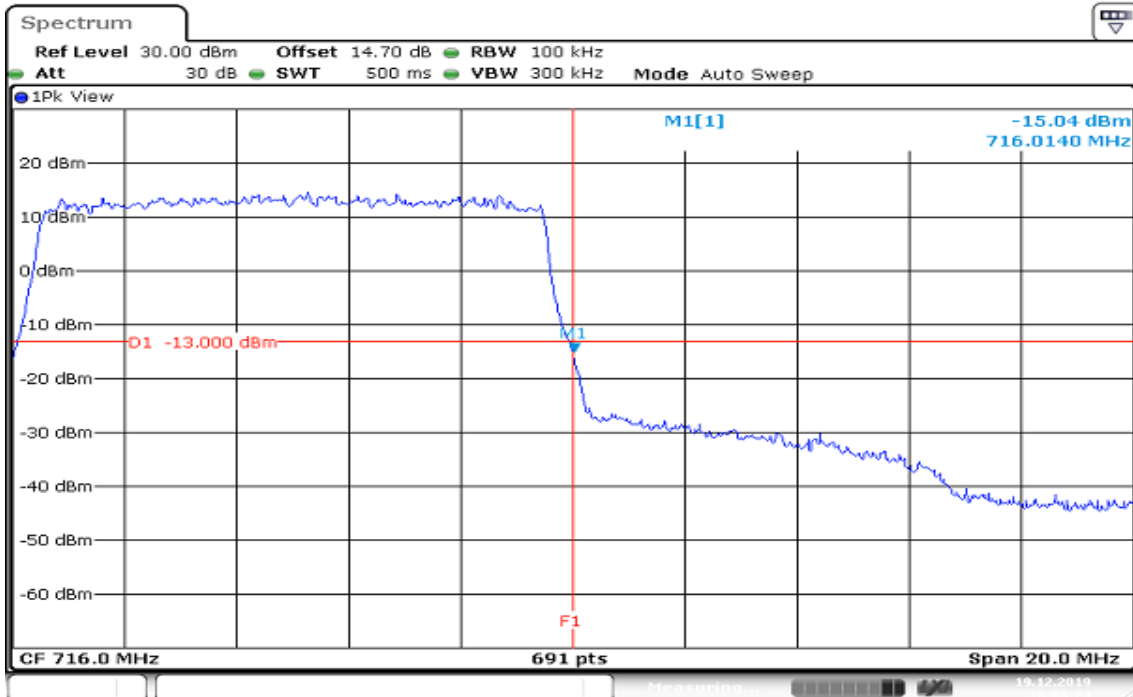

Date: 19.DEC.2019 16:08:25

Report No.: T191120D05-RP8

CHANNEL BANDWIDTH: 1.4MHz / 16QAM/ 1RB ALLOCATION LOWER BAND EDGE

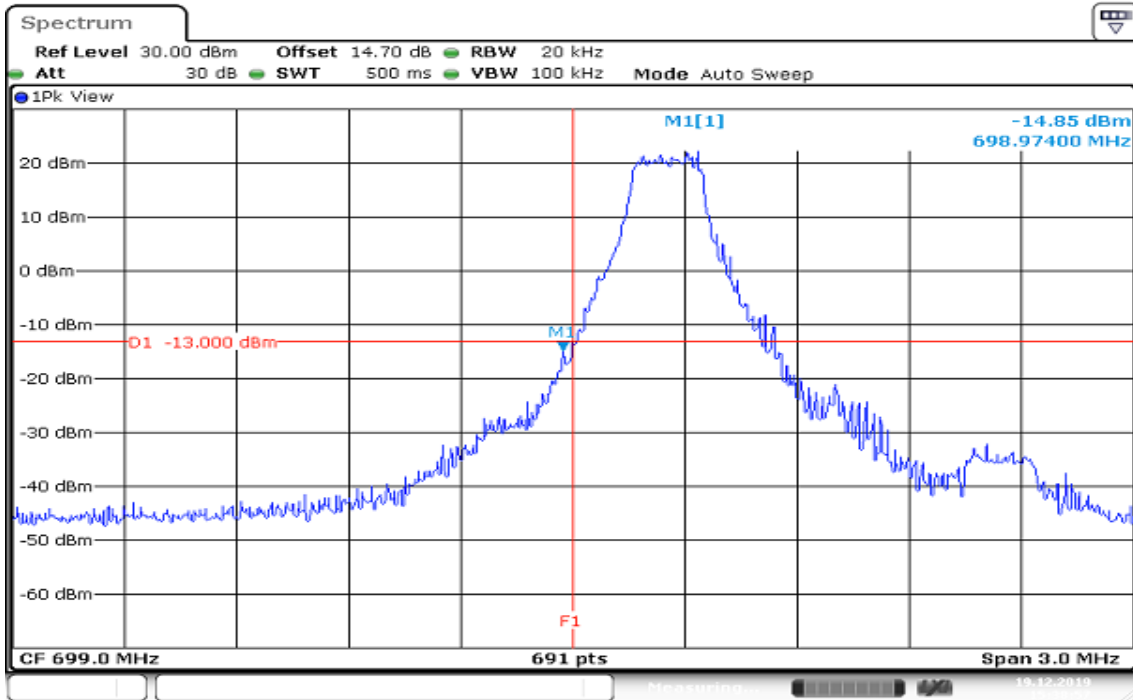

HIGHER BAND EDGE

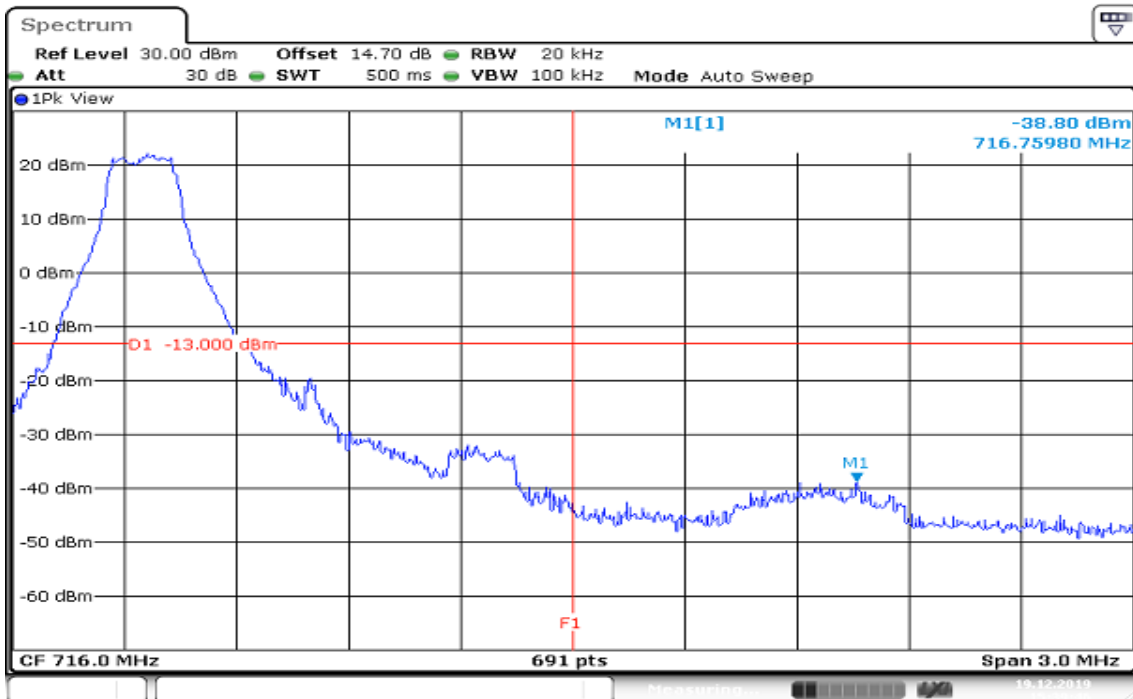

Report No.: T191120D05-RP8

CHANNEL BANDWIDTH: 3MHz / 16QAM/ 1RB ALLOCATION LOWER BAND EDGE

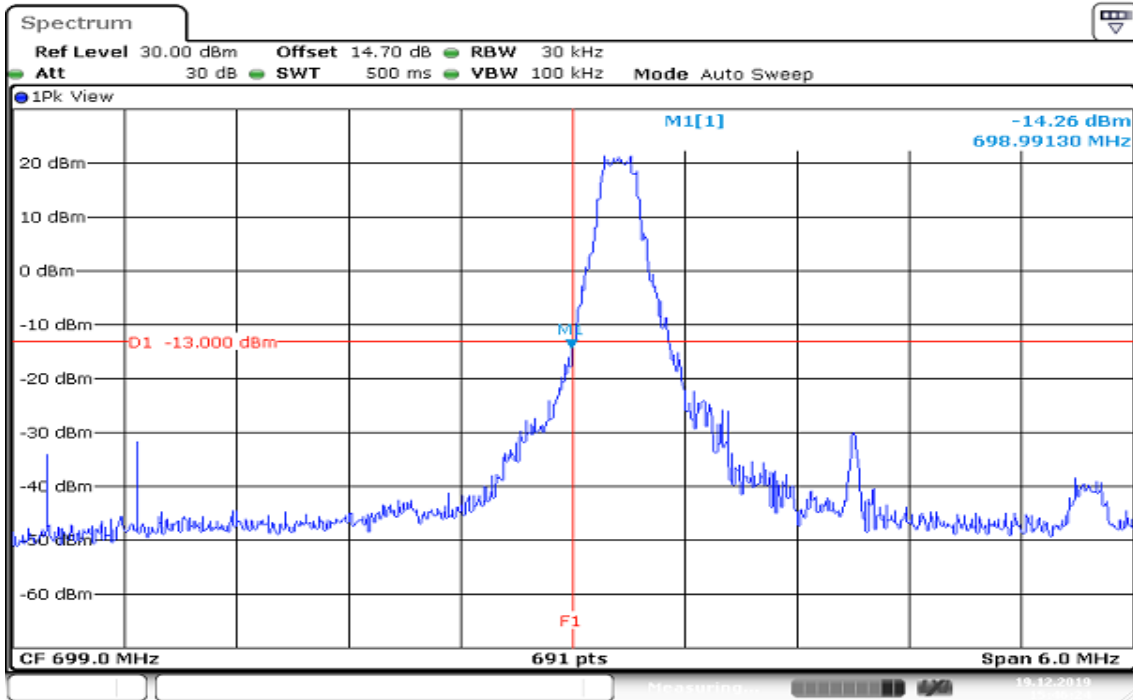

Date: 19.DEC.2019 15:46:24

HIGHER BAND EDGE

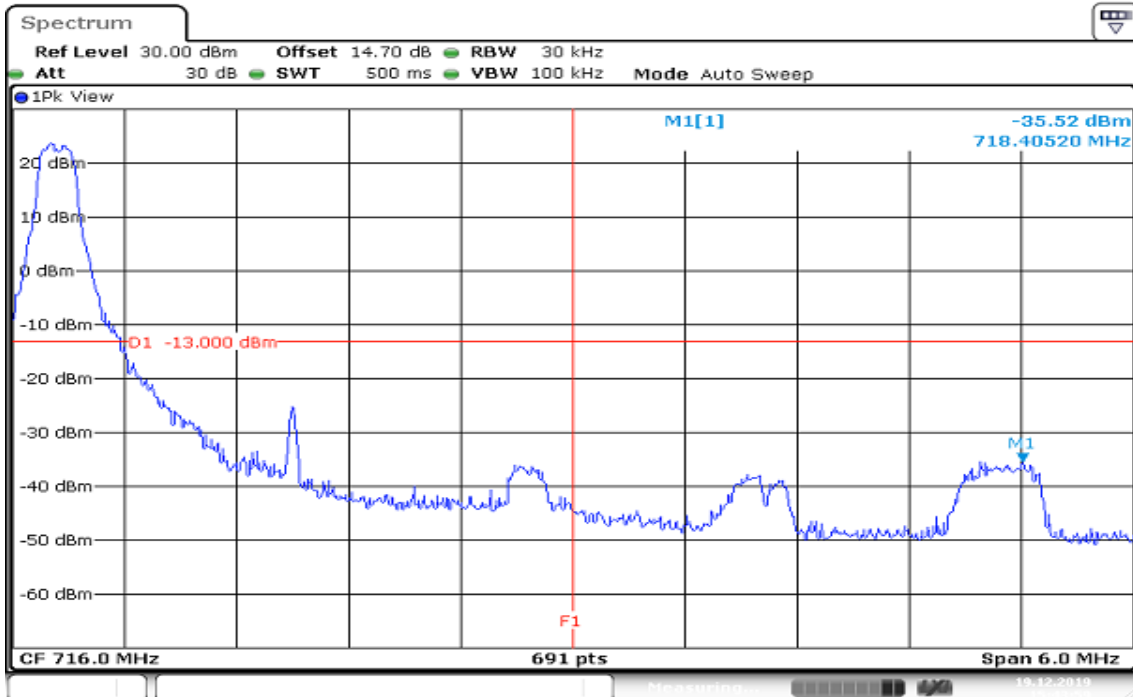

Date: 19.DEC.2019 15:44:00

Report No.: T191120D05-RP8

CHANNEL BANDWIDTH: 5MHz / 16QAM/ 1RB ALLOCATION LOWER BAND EDGE

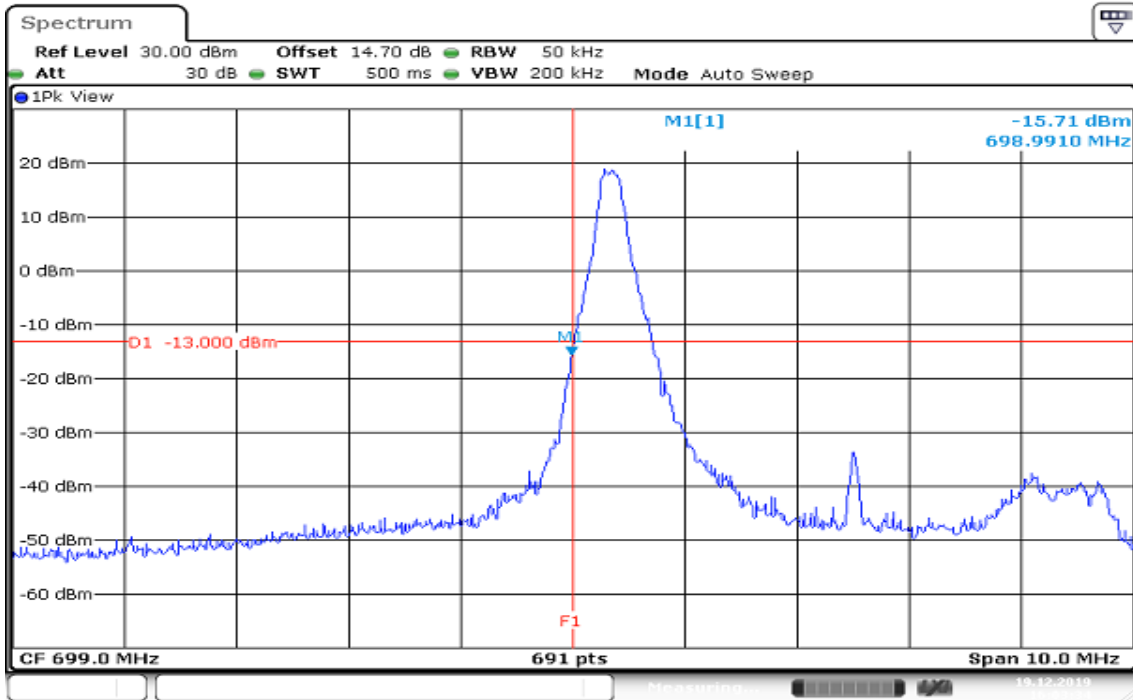

HIGHER BAND EDGE

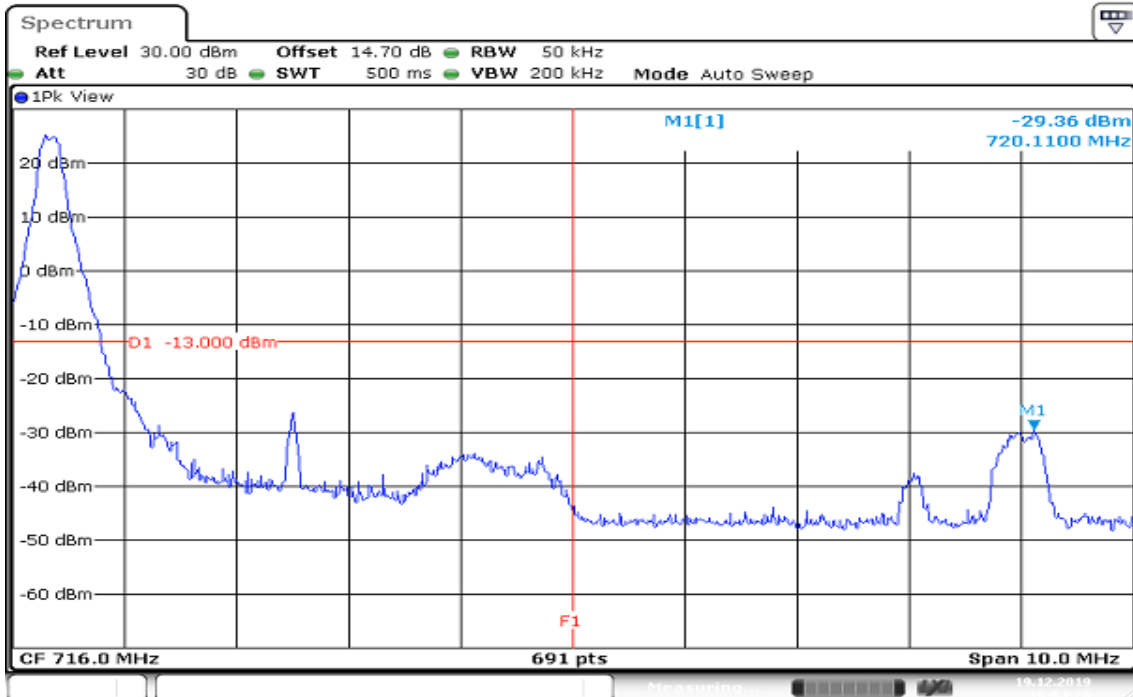

Report No.: T191120D05-RP8

CHANNEL BANDWIDTH: 10MHz / 16QAM/ 1RB ALLOCATION LOWER BAND EDGE

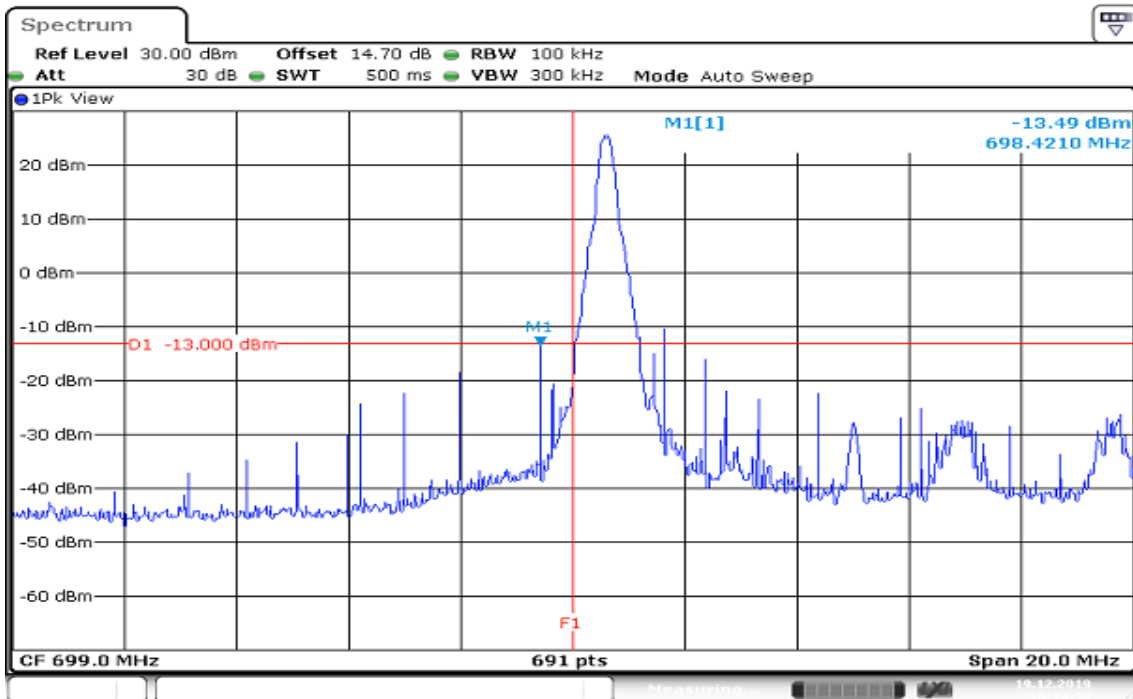

Date: 19.DEC.2019 16:14:30

HIGHER BAND EDGE

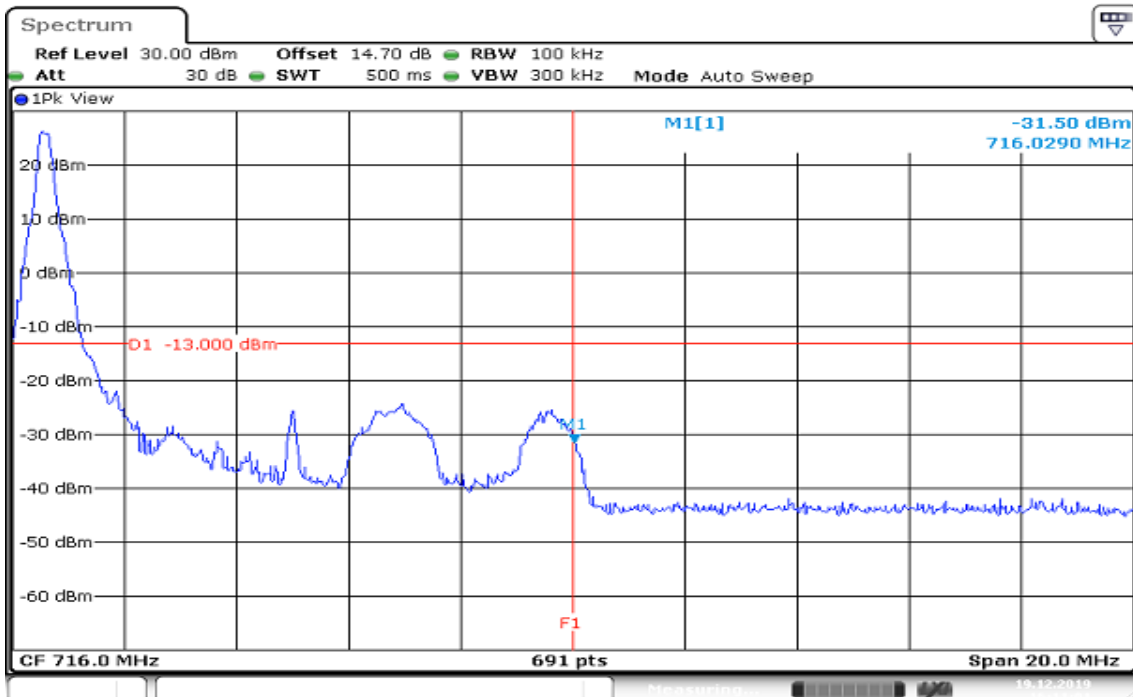

Date: 19.DEC.2019 16:11:02

CHANNEL BANDWIDTH: 1.4MHz / 16QAM/ FULLRB ALLOCATION LOWER BAND EDGE

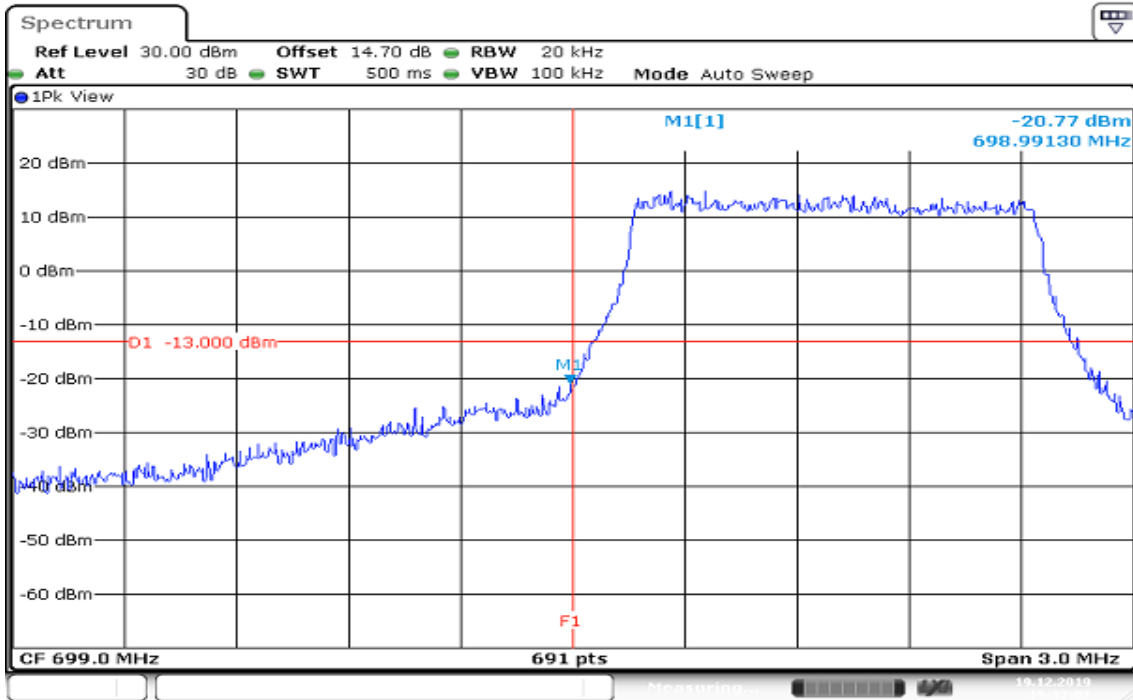

HIGHER BAND EDGE

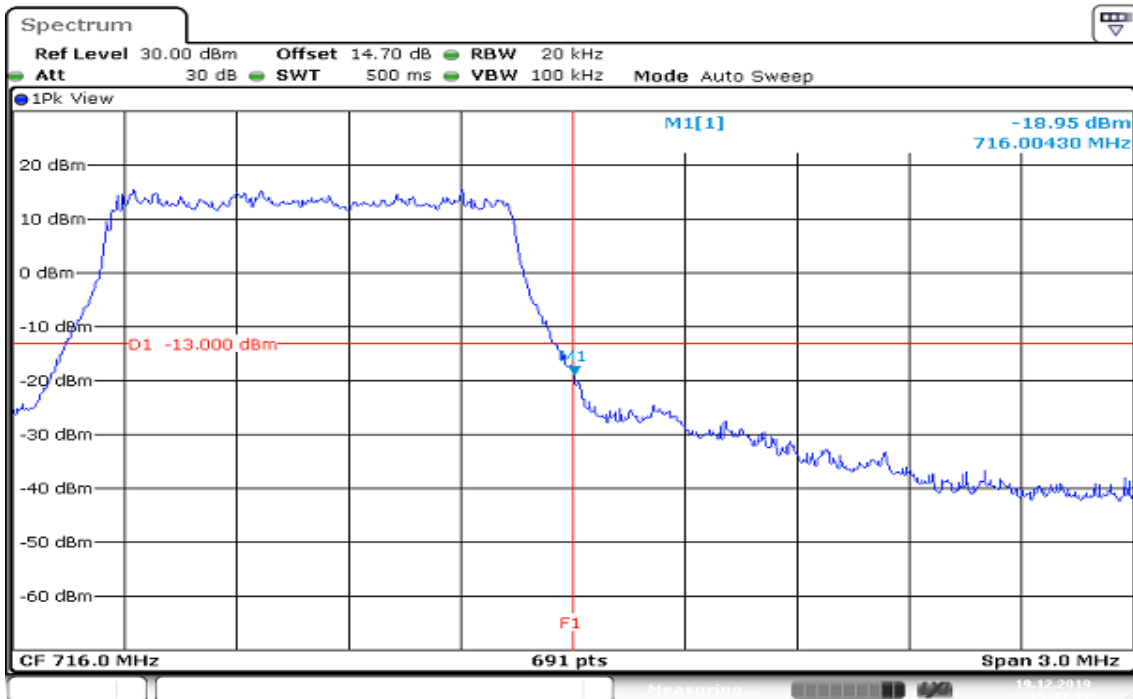

CHANNEL BANDWIDTH: 3MHz / 16QAM/ FULLRB ALLOCATION LOWER BAND EDGE

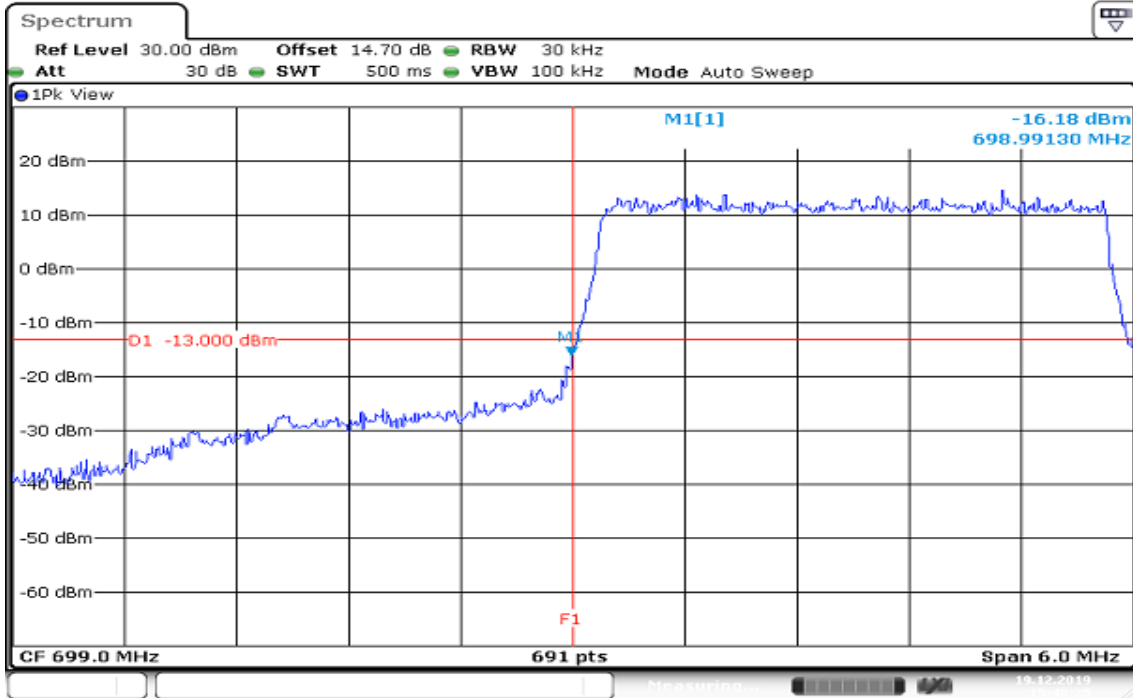

HIGHER BAND EDGE

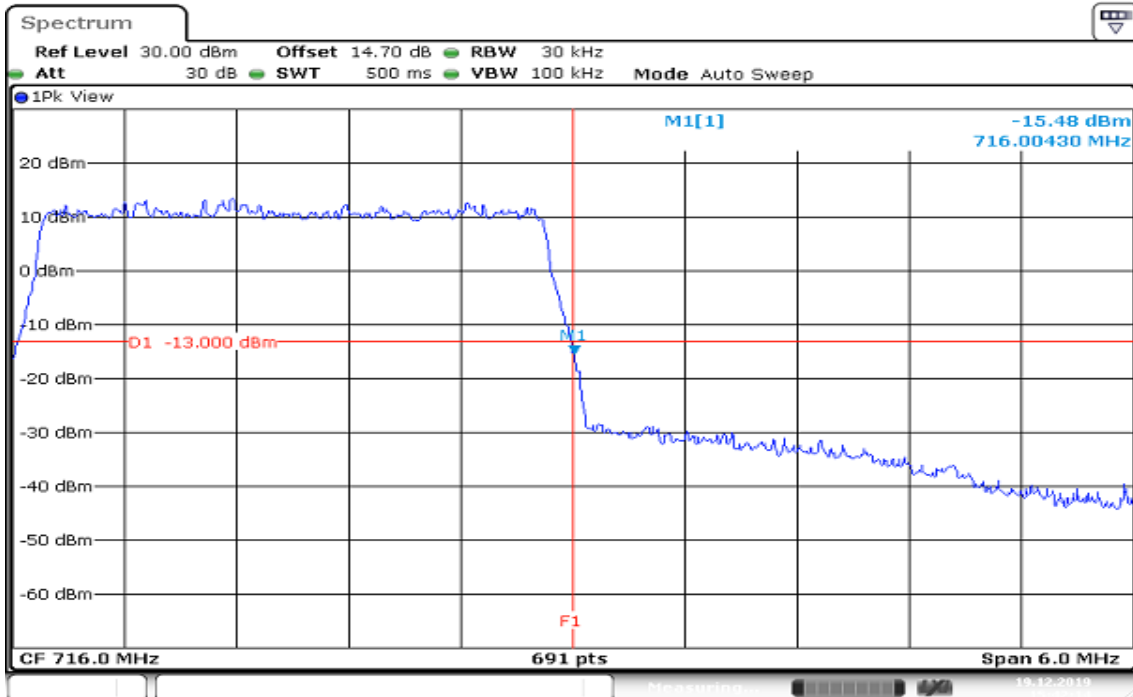

Report No.: T191120D05-RP8

CHANNEL BANDWIDTH: 5MHz / 16QAM/ FULLRB ALLOCATION LOWER BAND EDGE

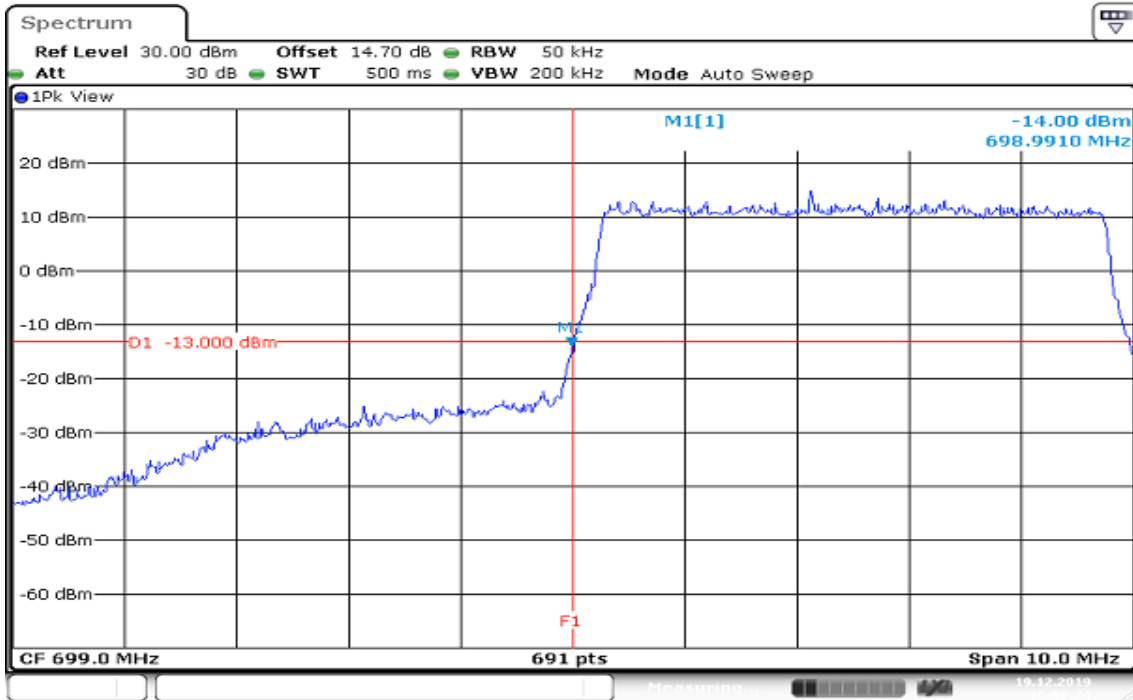

Date: 19.DEC.2019 16:00:24

HIGHER BAND EDGE

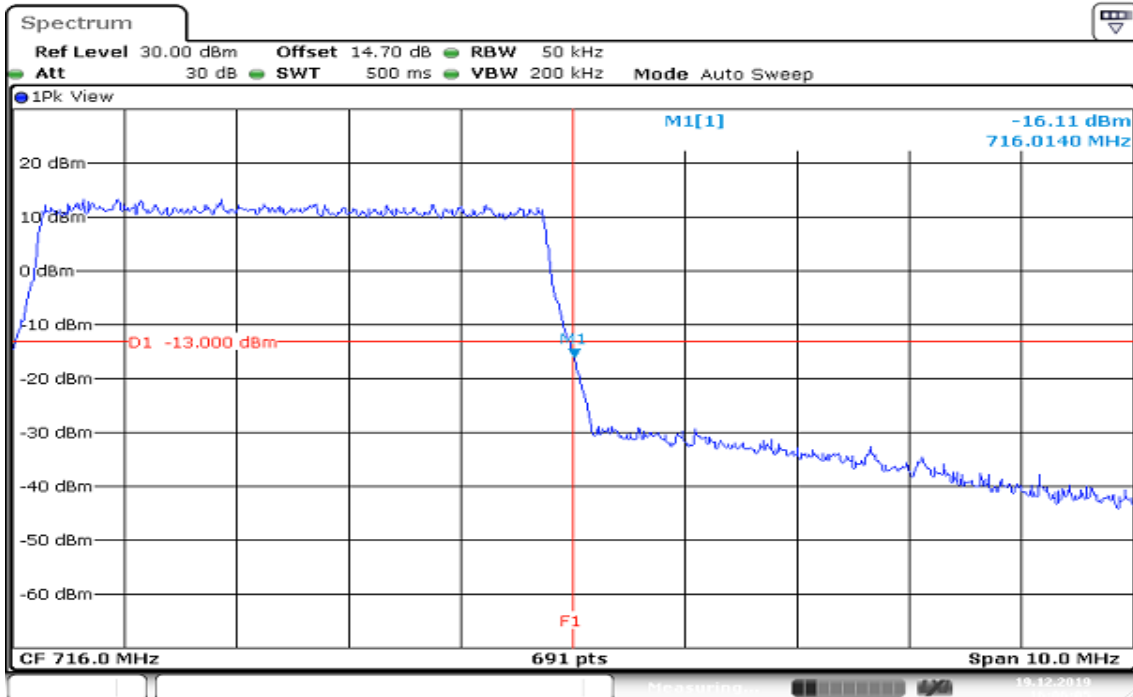

Date: 19.DEC.2019 16:06:05

Report No.: T191120D05-RP8

CHANNEL BANDWIDTH: 10MHz / 16QAM/ FULLRB ALLOCATION LOWER BAND EDGE

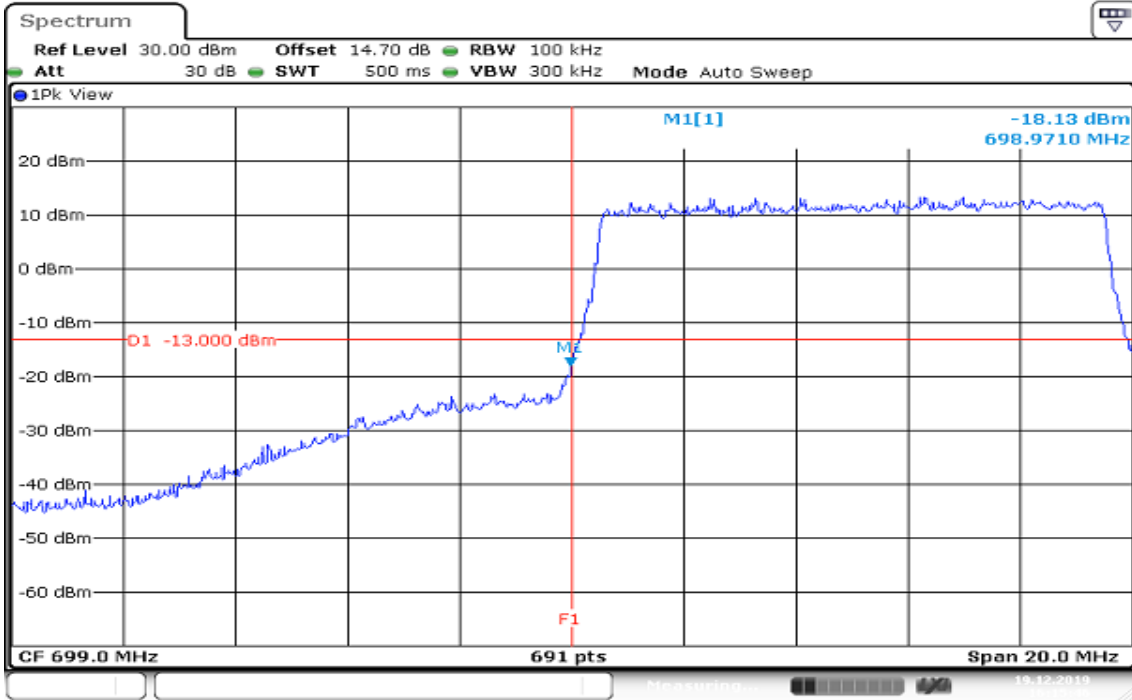

Date: 19.DEC.2019 16:15:46

HIGHER BAND EDGE

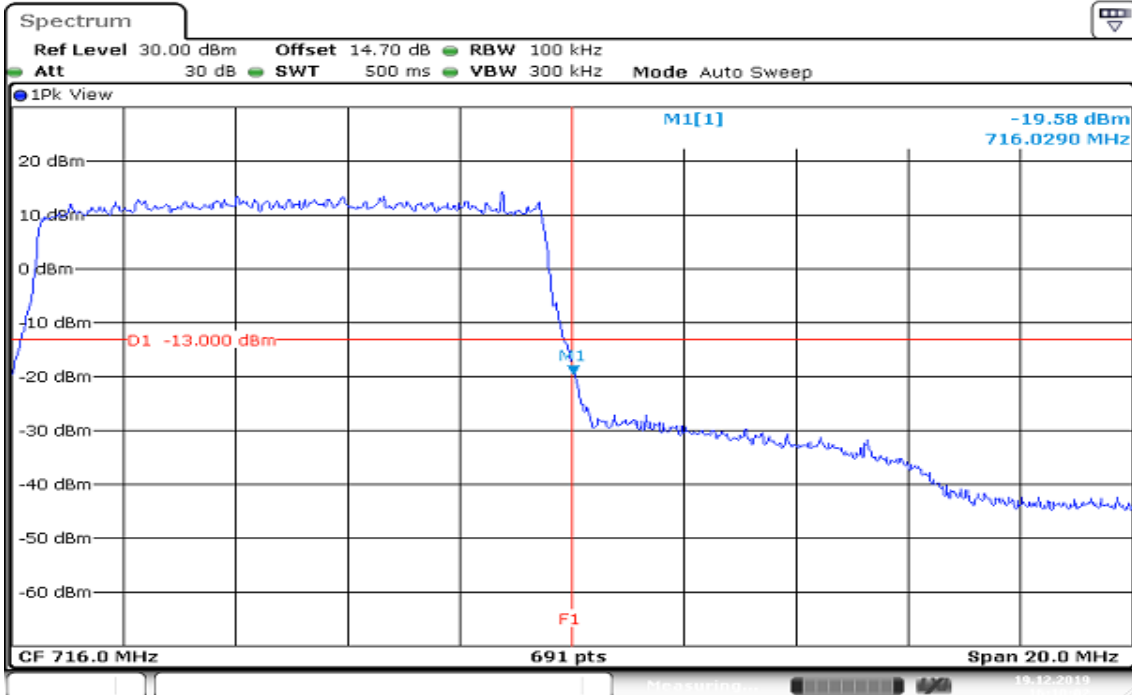

Date: 19.DEC.2019 16:10:02

8.6 CONDUCTED SPURIOUS EMISSIONS

LIMITS

The power of any emission outside a licensee's frequency block shall be attenuated below the transmitter power (P) by at least $43 + 10 \log_{10}(P)$ dB. The limit of emission equal to -13dBm

TEST PROCEDURES

1. According to KDB 971168D01, photograph 6.0
2. The EUT was connect to spectrum analyzer and call box.
3. The RF output of EUT was connected to the spectrum analyzer.
4. Set the spectrum analyzer , RBW=1MHz, VBW=3MHz.
5. Record the maximum spurious emission.
6. The fundamental frequency should be excluded against the limit in operating band.

Report No.: T191120D05-RP8

TEST RESULTS

LTE Band 12

CHANNEL BANDWIDTH: 1.4MHz / QPSK / 1RB

CH Low

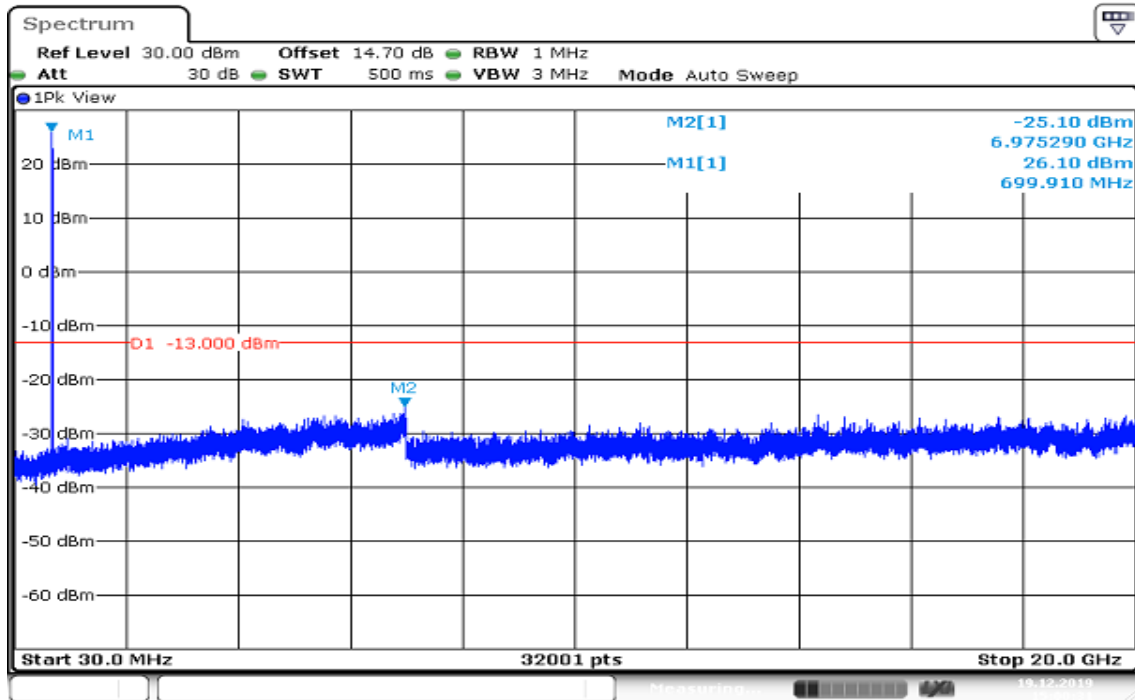

CH Mid

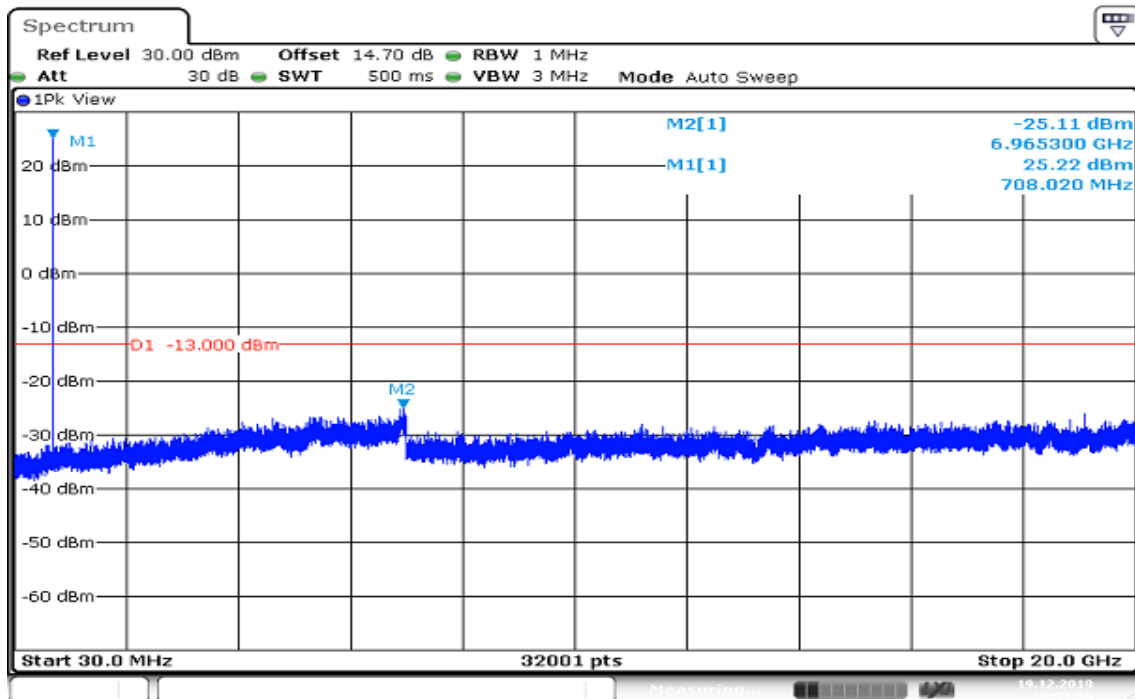

CH High

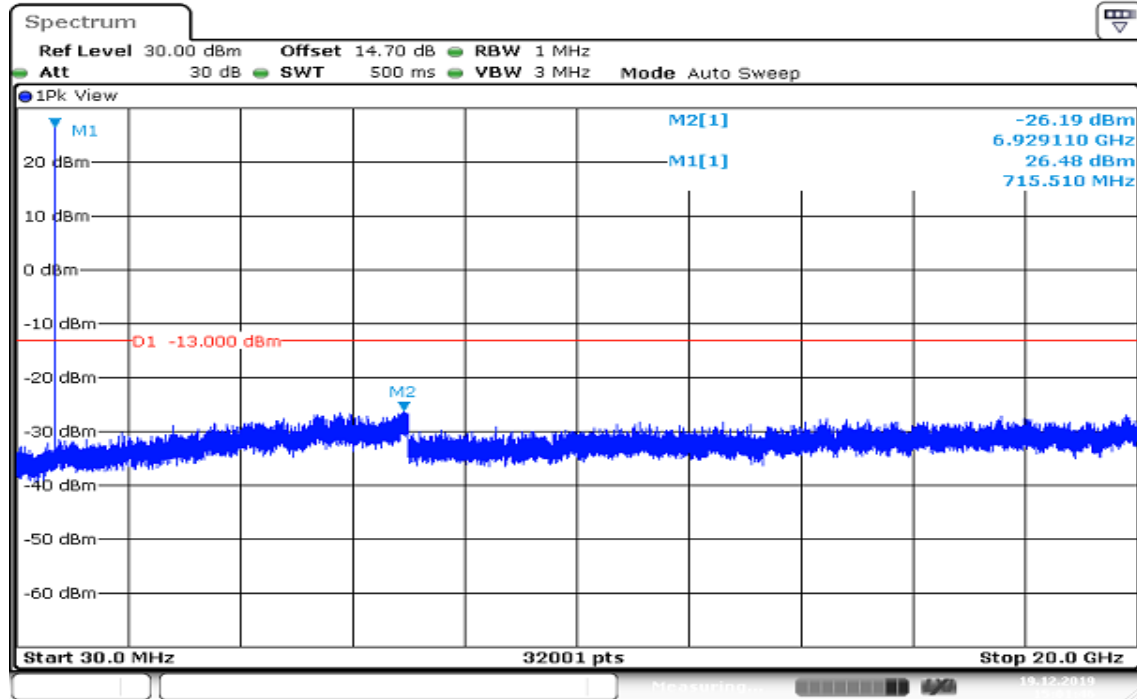

Date: 19.DEC.2019 15:01:46

CHANNEL BANDWIDTH: 3MHz / QPSK / 1RB CH Low

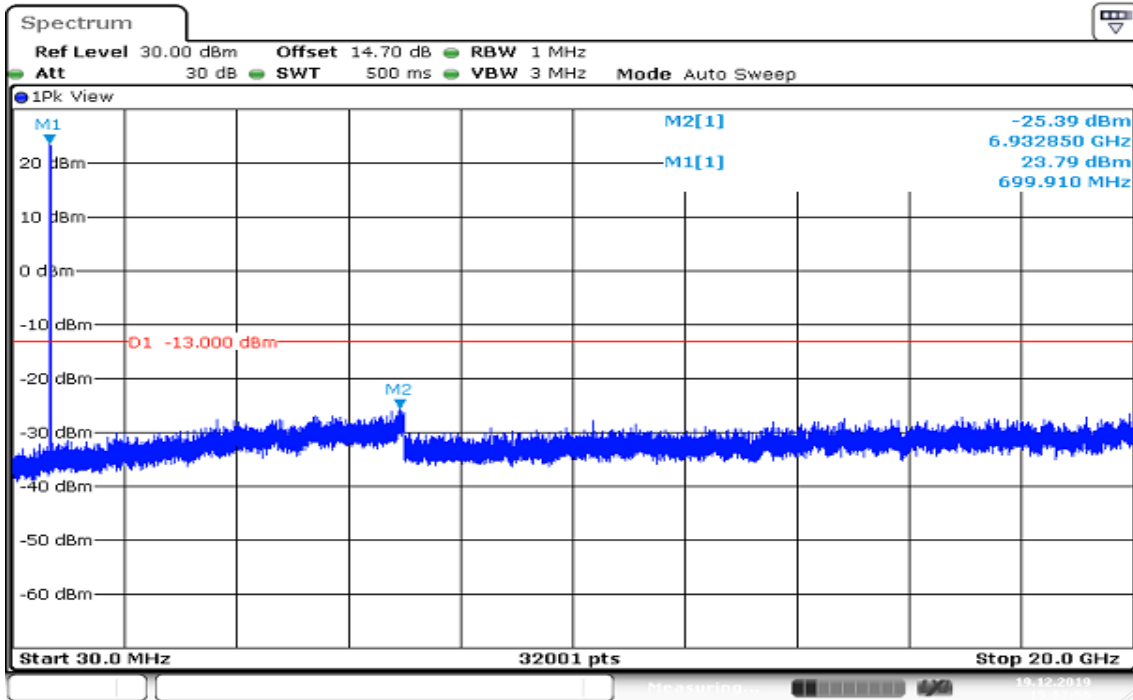

CH Mid

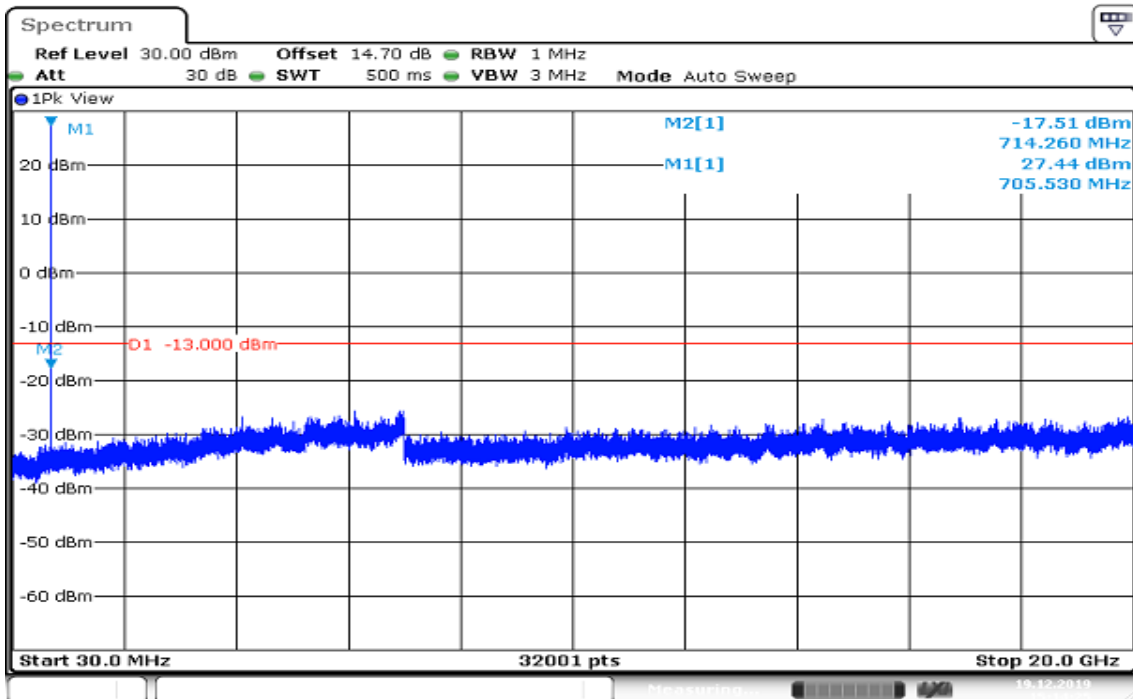

CH High

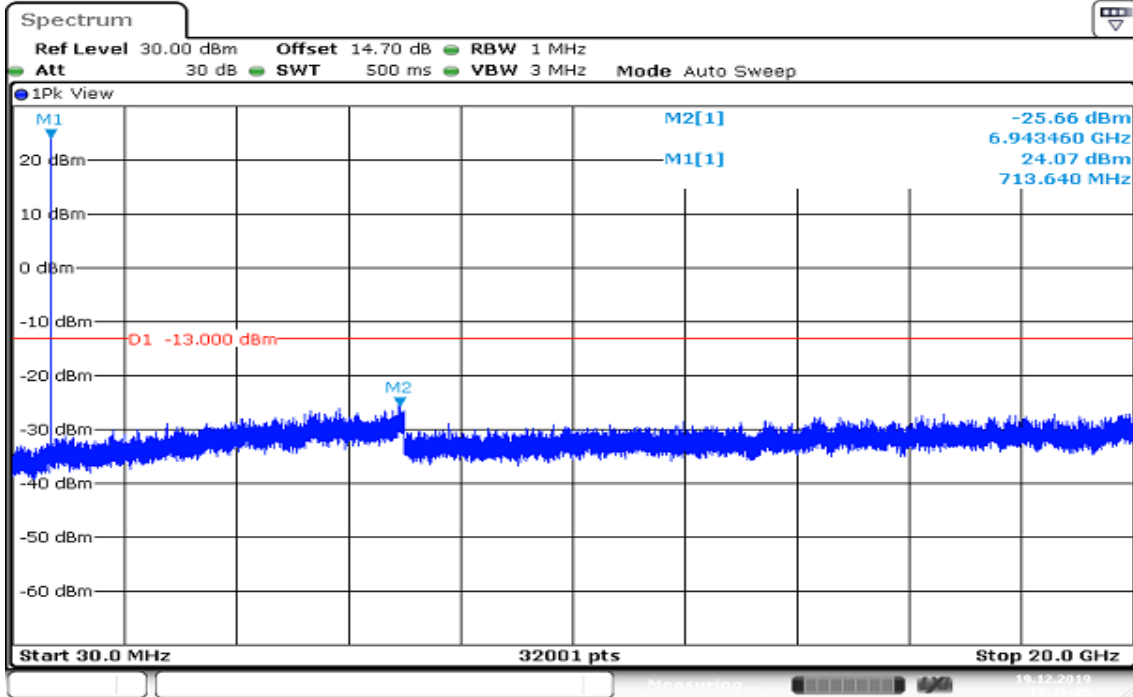

Date: 19.DEC.2019 15:16:26

Report No.: T191120D05-RP8

CHANNEL BANDWIDTH: 5MHz /QPSK / 1RB
CH Low

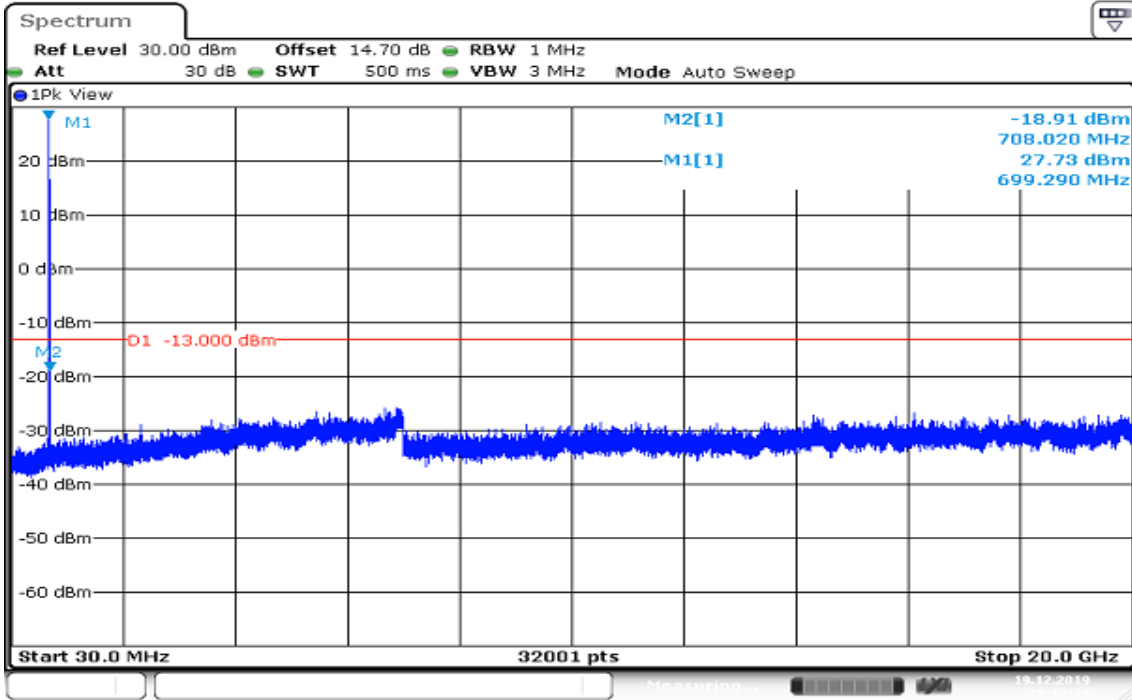

CH Mid

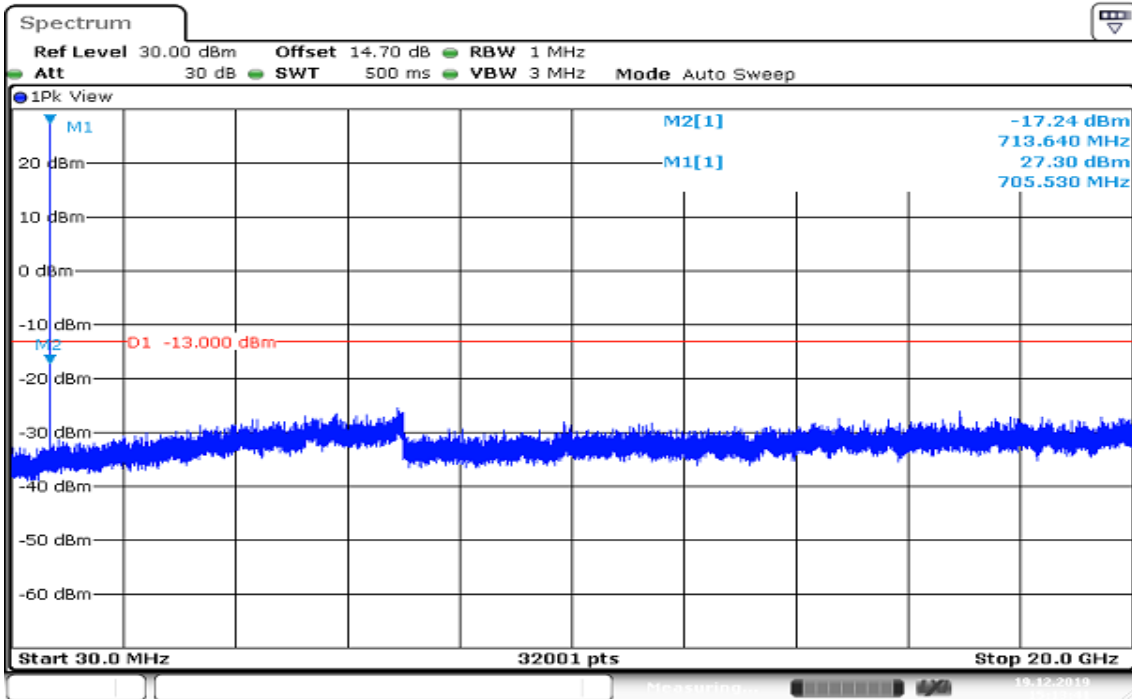

CH High

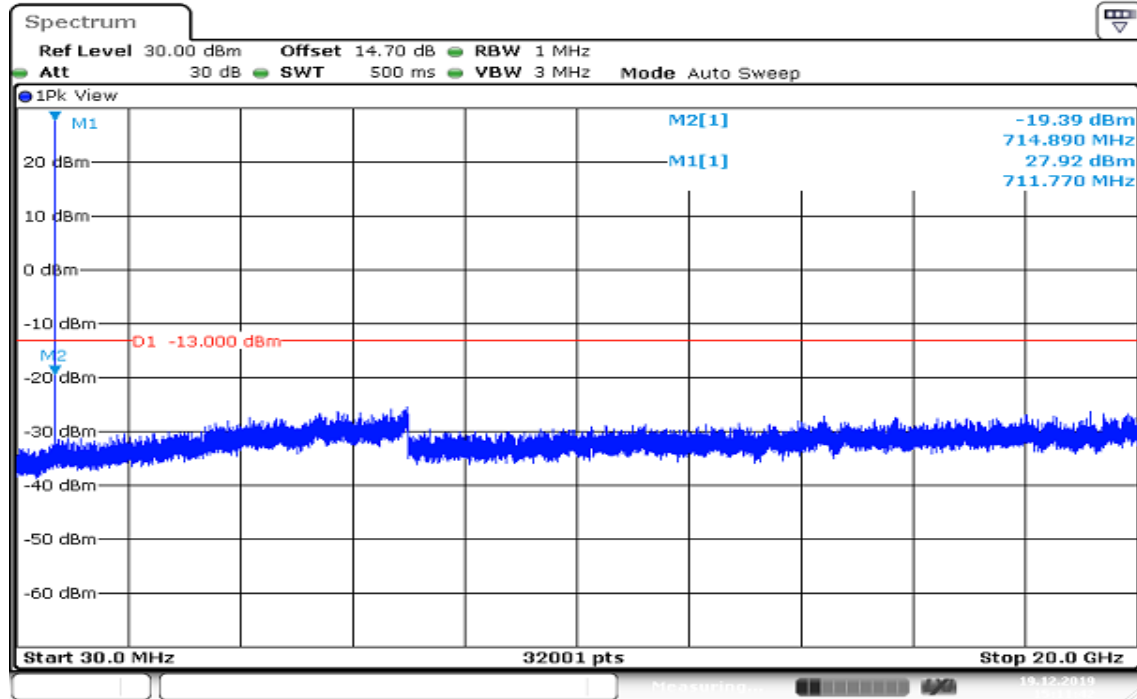

Date: 19.DEC.2019 15:11:43

CHANNEL BANDWIDTH: 10MHz /QPSK / 1RB CH Low

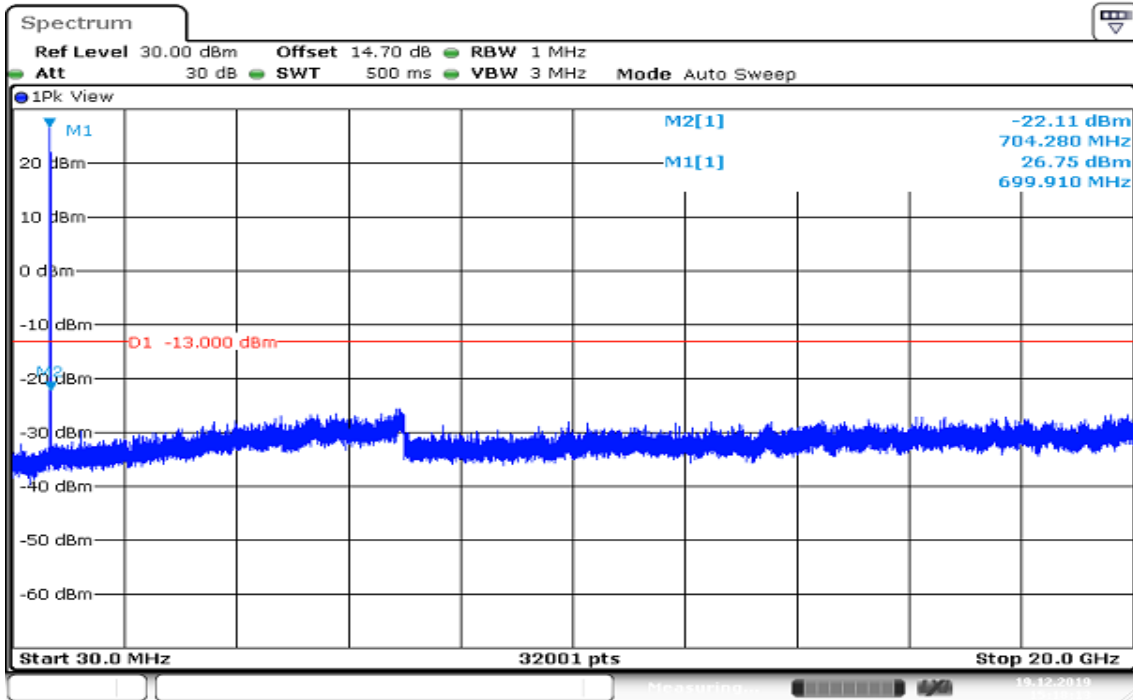

CH Mid

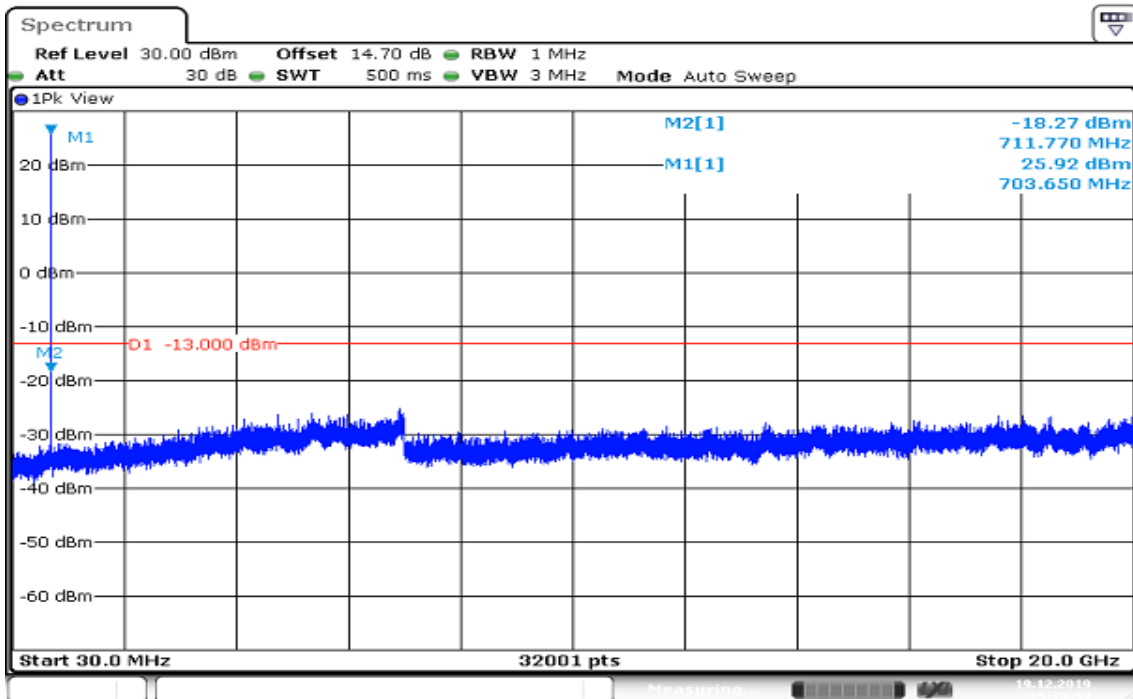

CH High

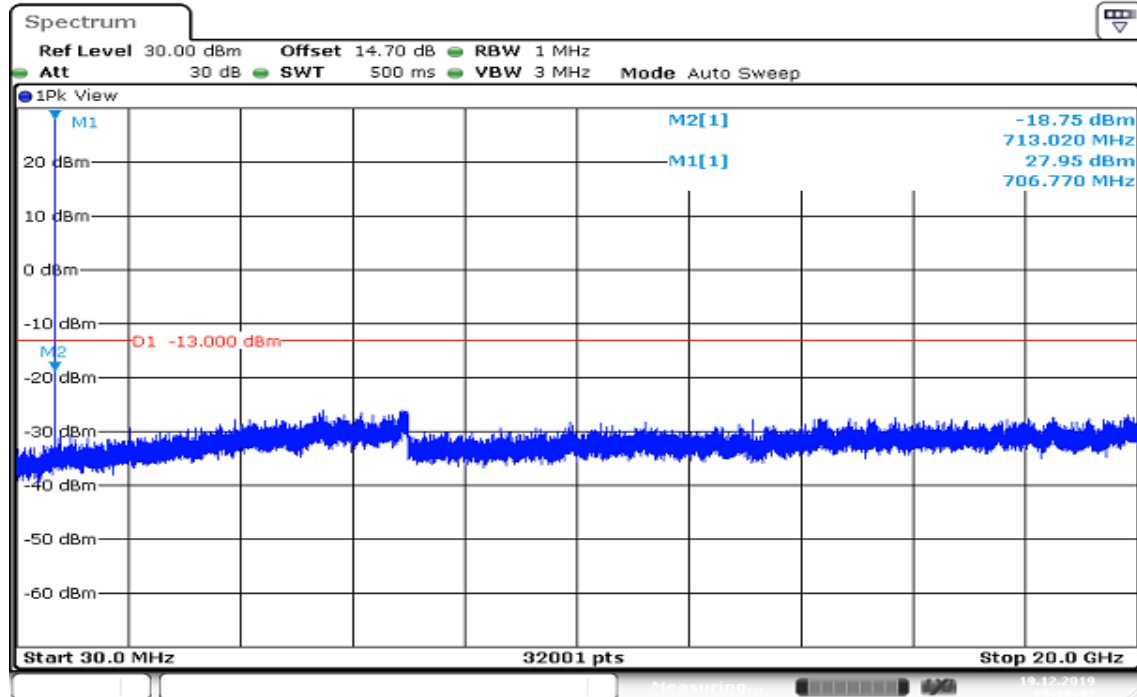

CHANNEL BANDWIDTH: 1.4MHz /16QAM / 1RB CH Low

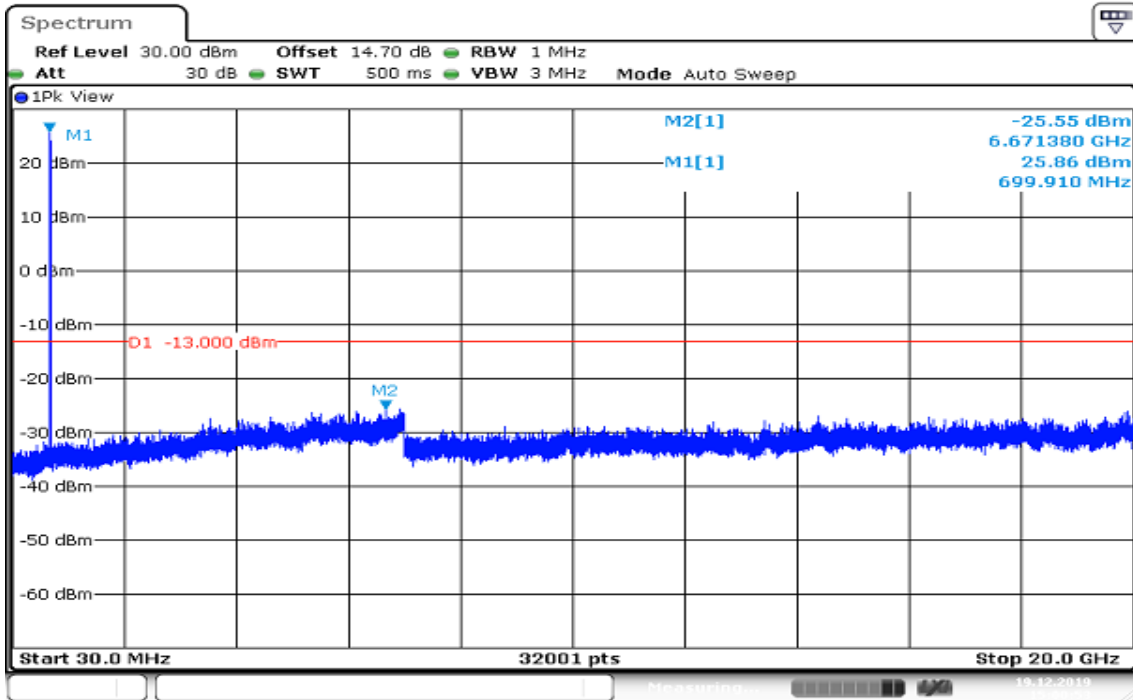

CH Mid

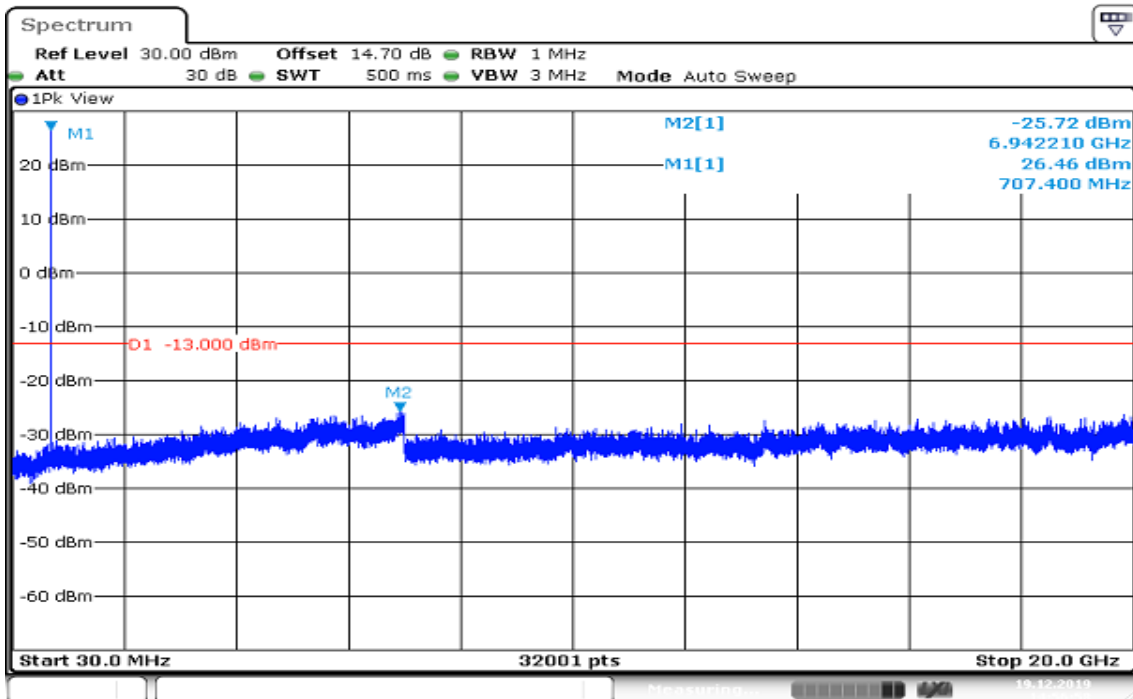

CH High

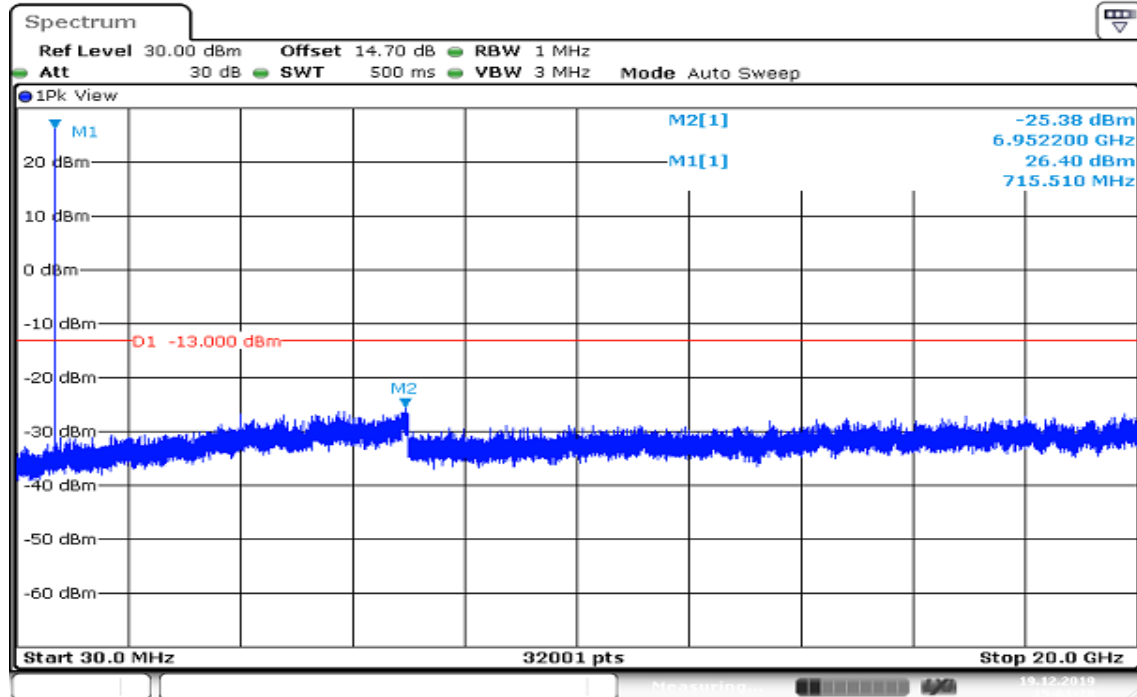

Date: 19.DEC.2019 15:01:28

Report No.: T191120D05-RP8

CHANNEL BANDWIDTH: 3MHz /16QAM / 1RB CH Low

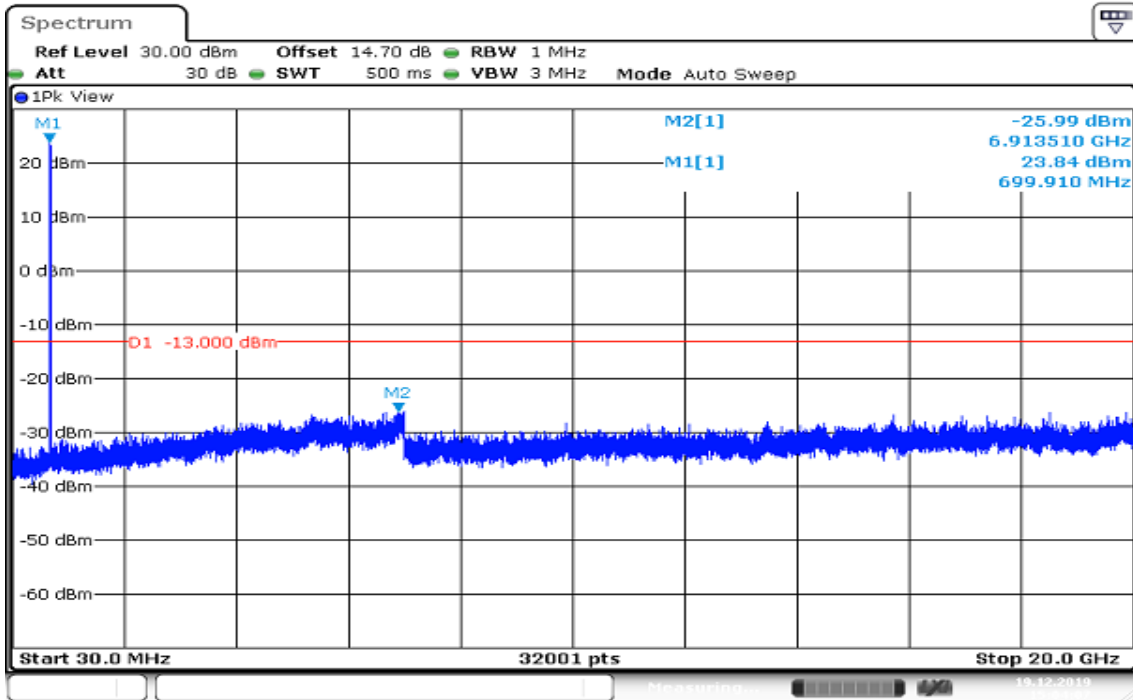

CH Mid

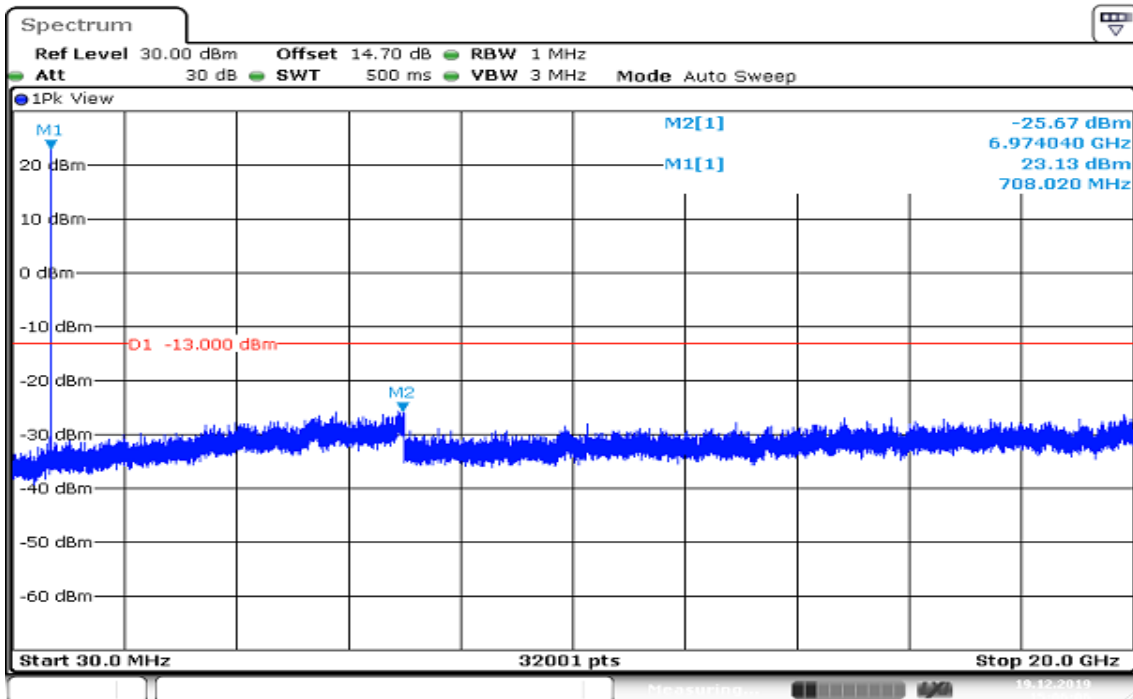

CH High

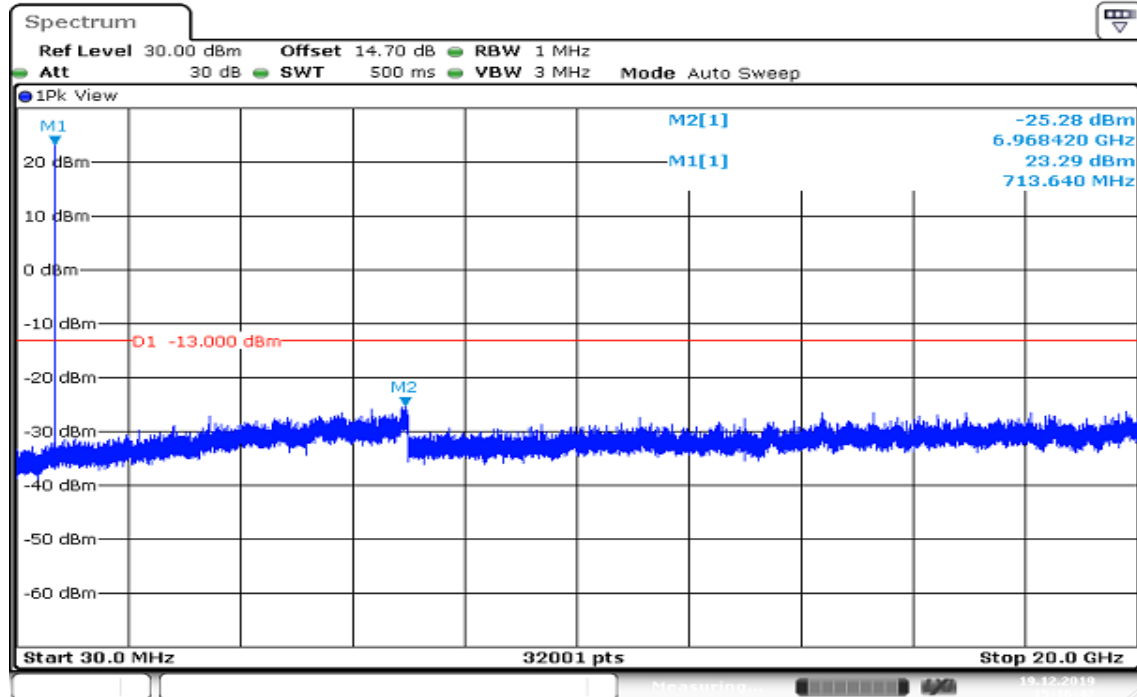

Date: 19.DEC.2019 15:16:48

CHANNEL BANDWIDTH:5MHz /16QAM / 1RB CH Low

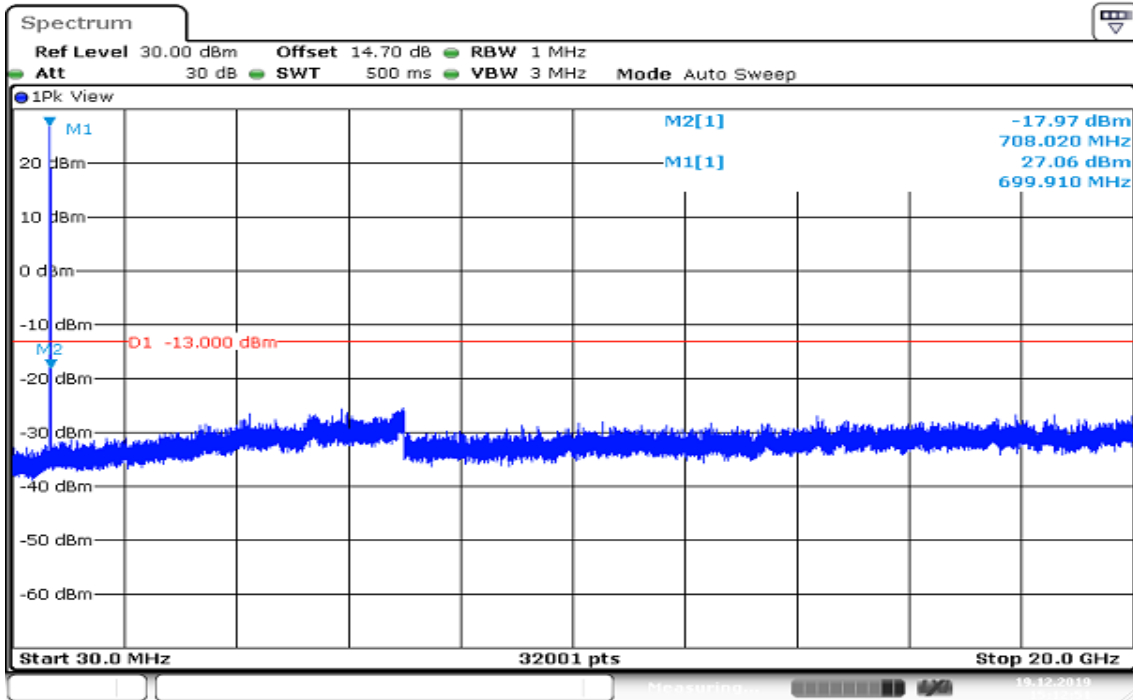

CH Mid

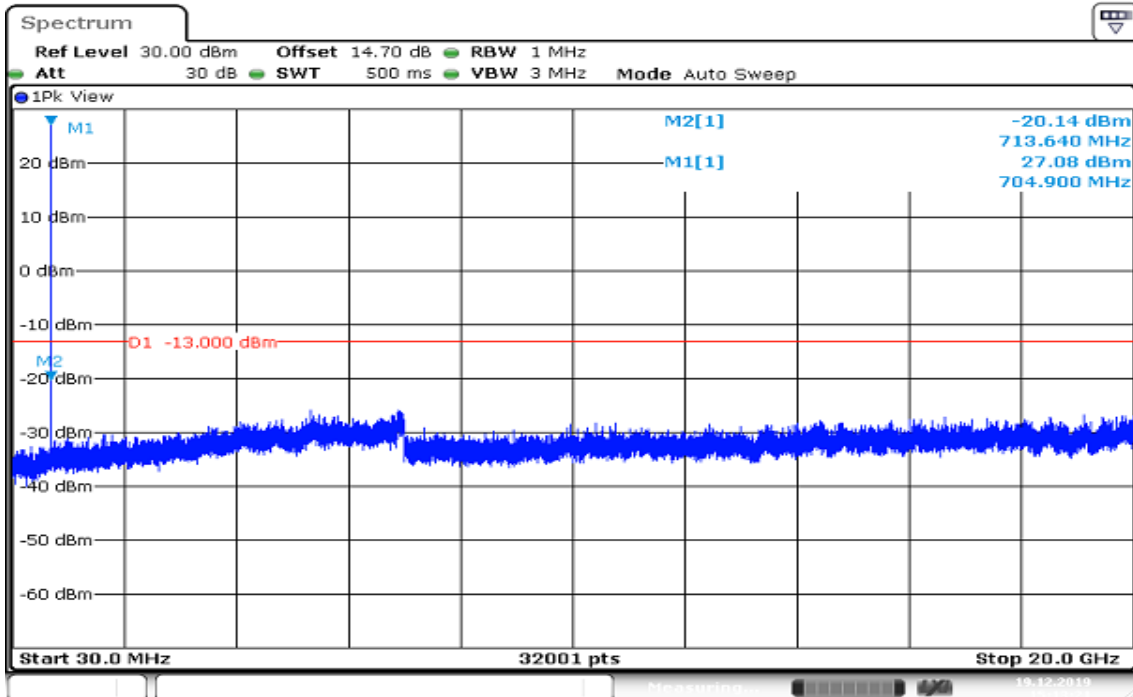

CH High

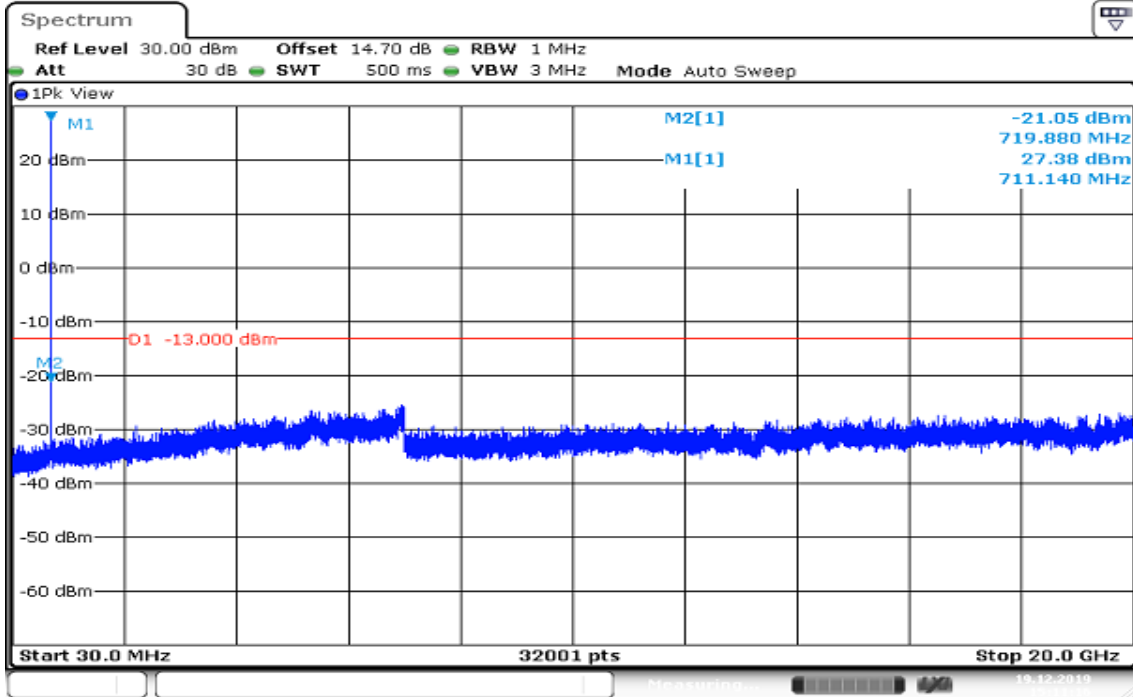

Date: 19. DEC. 2019 15:11:17

Report No.: T191120D05-RP8

CHANNEL BANDWIDTH:10MHz /16QAM / 1RB CH Low

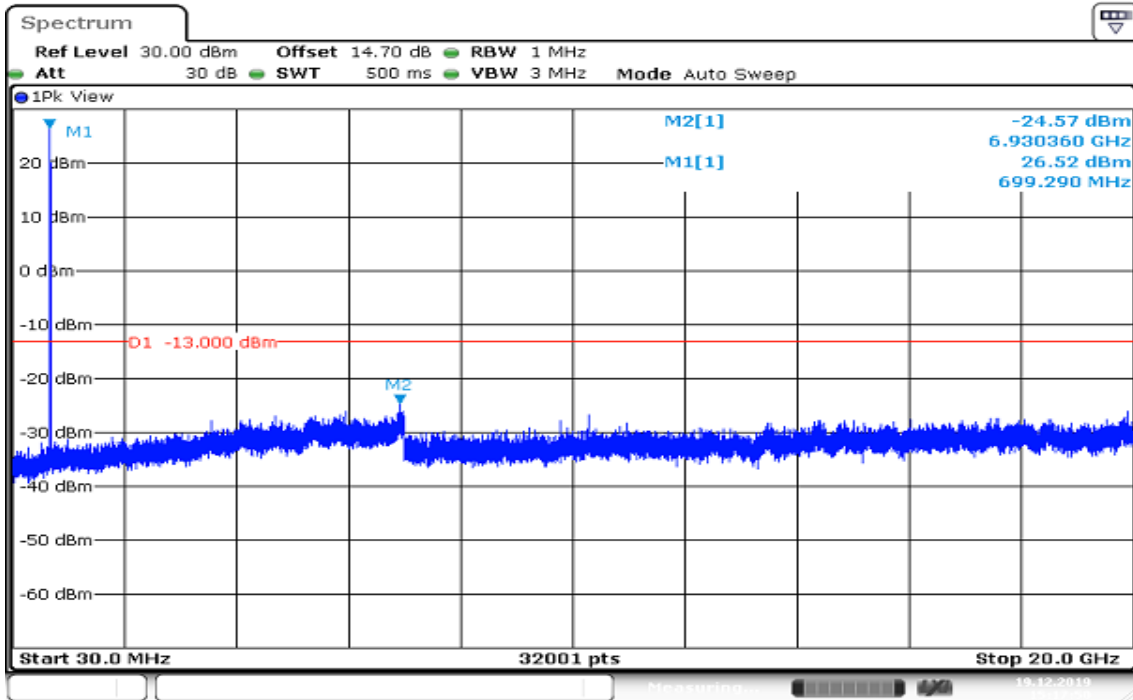

CH Mid

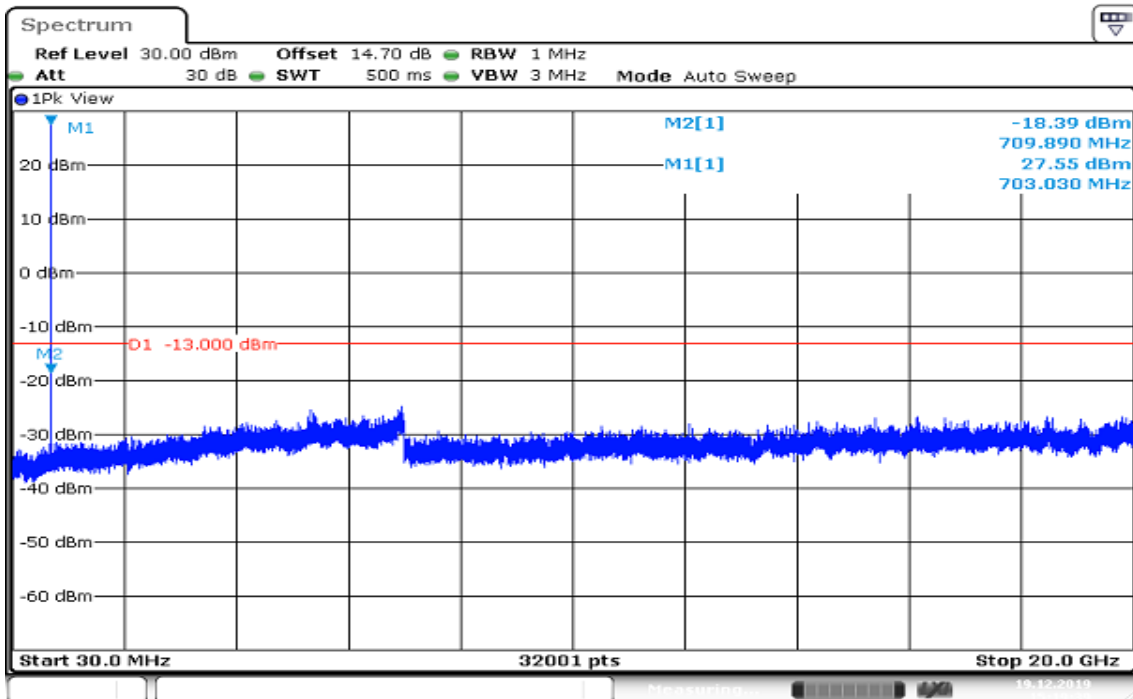

CH High

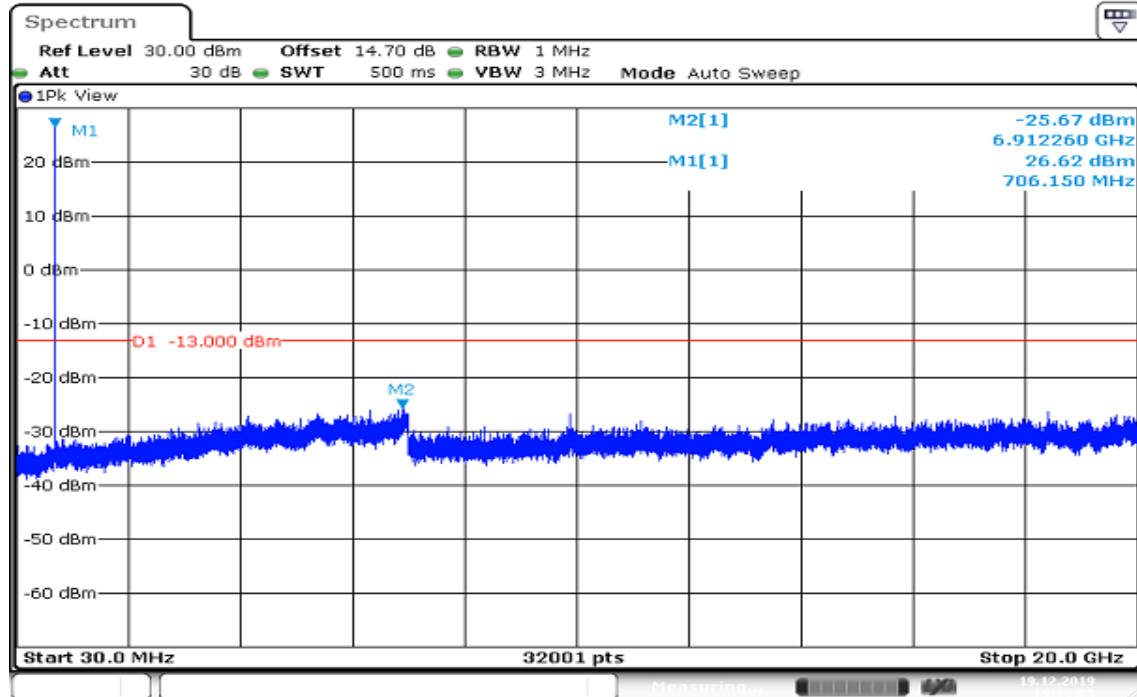

Date: 19. DEC. 2019 15:19:06

8.7 RADIATED EMISSION MEASUREMENT

LIMITS

FCC §27.53(g), Band 12

(g) For operations in the 600 MHz band and the 698-746 MHz band, the power of any emission outside a licensee's frequency band(s) of operation shall be attenuated below the transmitter power (P) within the licensed band(s) of operation, measured in watts, by at least $43 + 10 \log (P)$ dB. Compliance with this provision is based on the use of measurement instrumentation employing a resolution bandwidth of 100 kilohertz or greater. However, in the 100 kilohertz bands immediately outside and adjacent to a licensee's frequency block, a resolution bandwidth of at least 30 kHz may be employed.

According to RSS-130, Band 12

The power of any unwanted emissions in any 100 kHz bandwidth on any frequency outside the frequency range(s) within which the equipment is designed to operate shall be attenuated below the transmitter power, P (dBW), by at least $43 + 10 \log_{10} p$ (watts), dB. However, in the 100 kHz band immediately outside the equipment's operating frequency range, a resolution bandwidth of 30 kHz may be employed.

Report No.: T191120D05-RP8

Test Configuration

Below 1 GHz

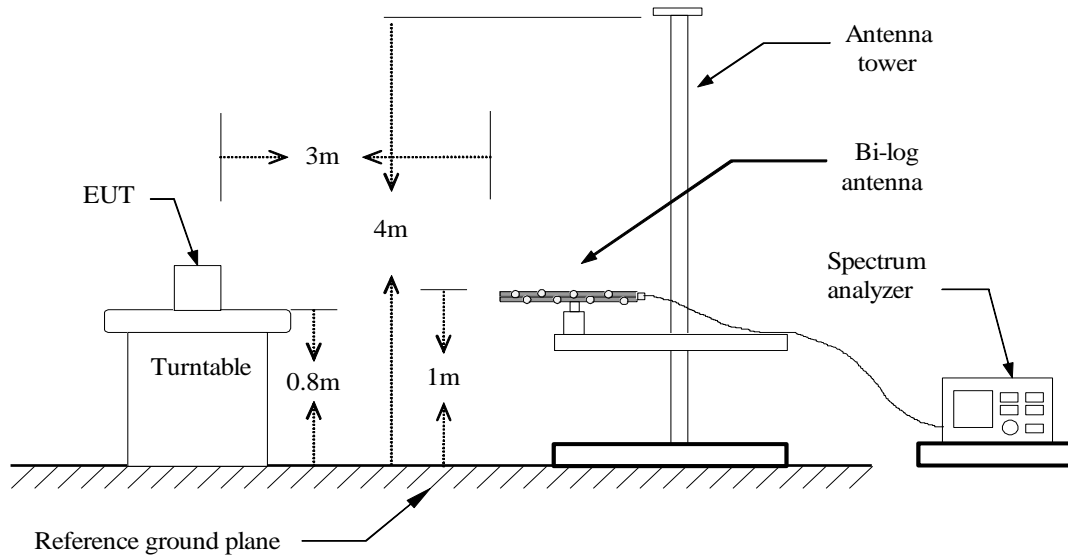

Above 1 GHz

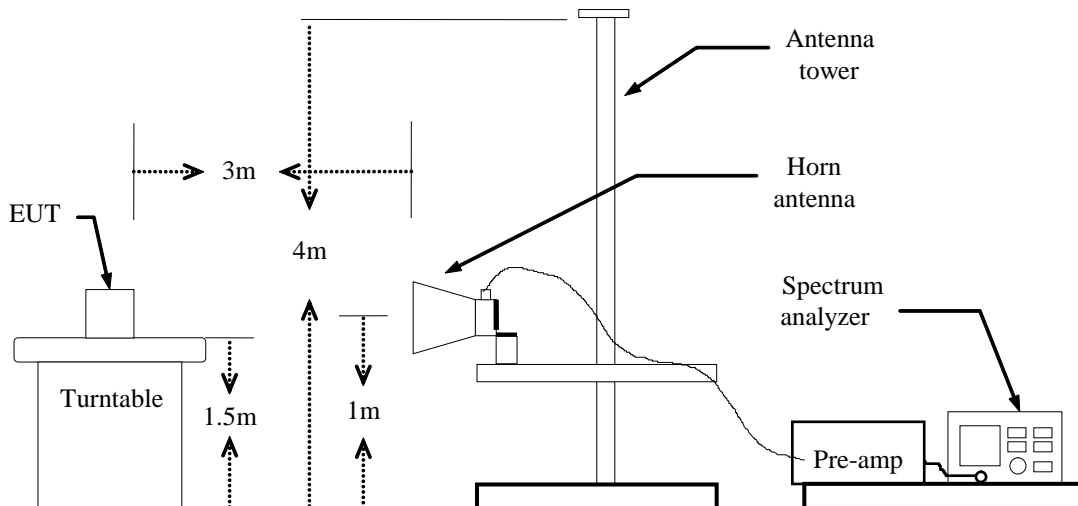

Report No.: T191120D05-RP8

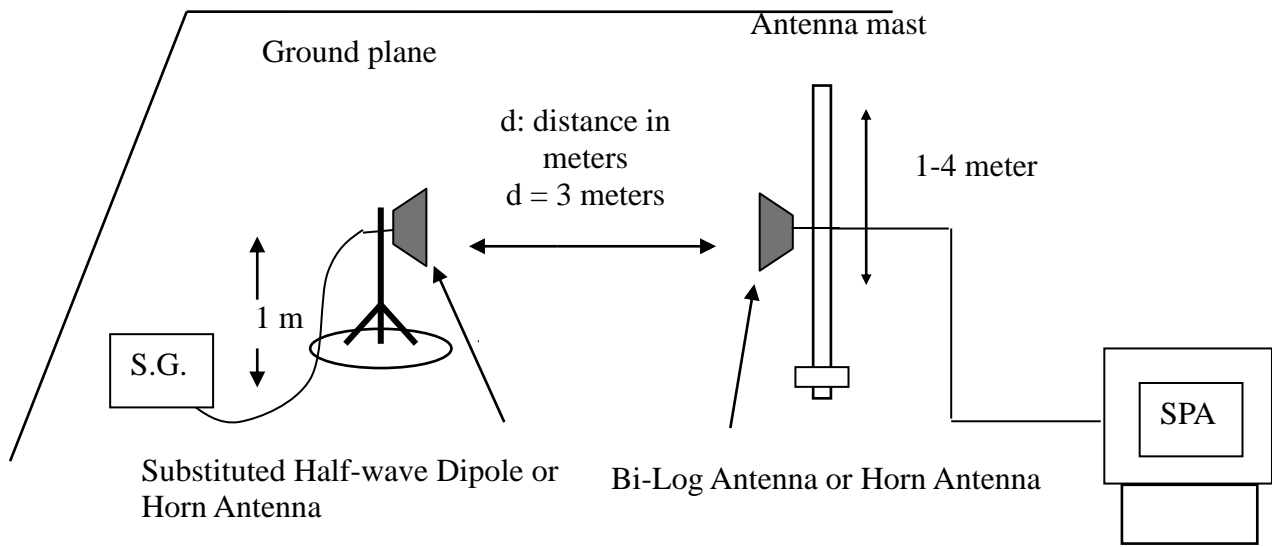
Substituted Method Test Set-up**TEST PROCEDURES**

1. According to KDB 971168 D01 and TIA-603-E.
2. The EUT was placed on a turntable
 - (1) Below 1G : 0.8m
 - (2) Above 1G : 1.5m
 - (3) EUT set 3m from the receiving antenna
 - (4) The table was rotated 360 degrees of the highest spurious emission to determine the position.
3. Set the spectrum analyzer , RBW=1MHz, VBW=3MHz.
4. A horn antenna was driven by a signal generator.
5. Tune the output power of signal generator to the same emission level with EUT maximum spurious emission.

Report No.: T191120D05-RP8

Test Results

LTE Band 12 / BW: 10MHz / QPSK / RB =1, RB Offset = 0

Operation Mode: Tx / Low CH **Test Date:** January 8, 2020
Temperature: 18.6°C **Tested by:** Jerry Chang
Humidity: 59% RH **Polarity:** Ver.

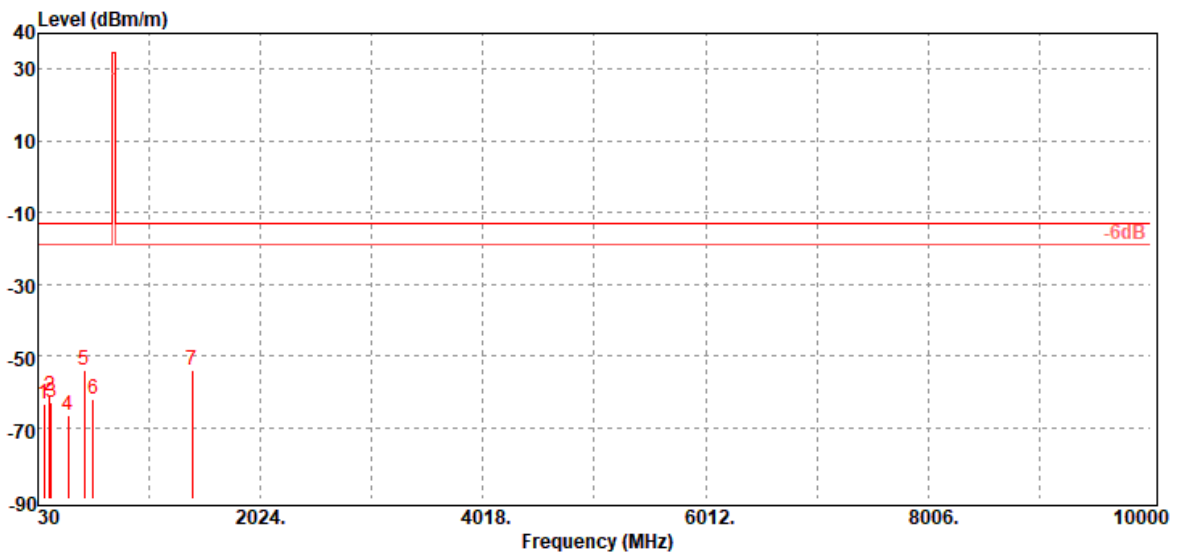

Freq. MHz	ERP/EIRP dBm	SG Output Level dBm	Antenna Gain dBd/dBi	Cable Loss dB	Limit dBm	Margin dB	Antenna Polarization (V/H)
86.26	-63.24	-54.93	-7.55	-0.76	-13.00	-50.24	V
131.85	-61.22	-50.47	-9.81	-0.94	-13.00	-48.22	V
150.28	-62.84	-54.73	-7.10	-1.01	-13.00	-49.84	V
299.66	-66.47	-63.03	-2.01	-1.43	-13.00	-53.47	V
444.19	-53.97	-50.12	-2.10	-1.75	-13.00	-40.97	V
526.64	-62.29	-59.07	-1.30	-1.92	-13.00	-49.29	V
1408.00	-53.87	-58.67	8.05	-3.25	-13.00	-40.87	V

Report No.: T191120D05-RP8

Operation Mode: Tx / Low CH
Temperature: 18.6°C
Humidity: 59% RH

Test Date: January 8, 2020
Tested by: Jerry Chang
Polarity: Hor.

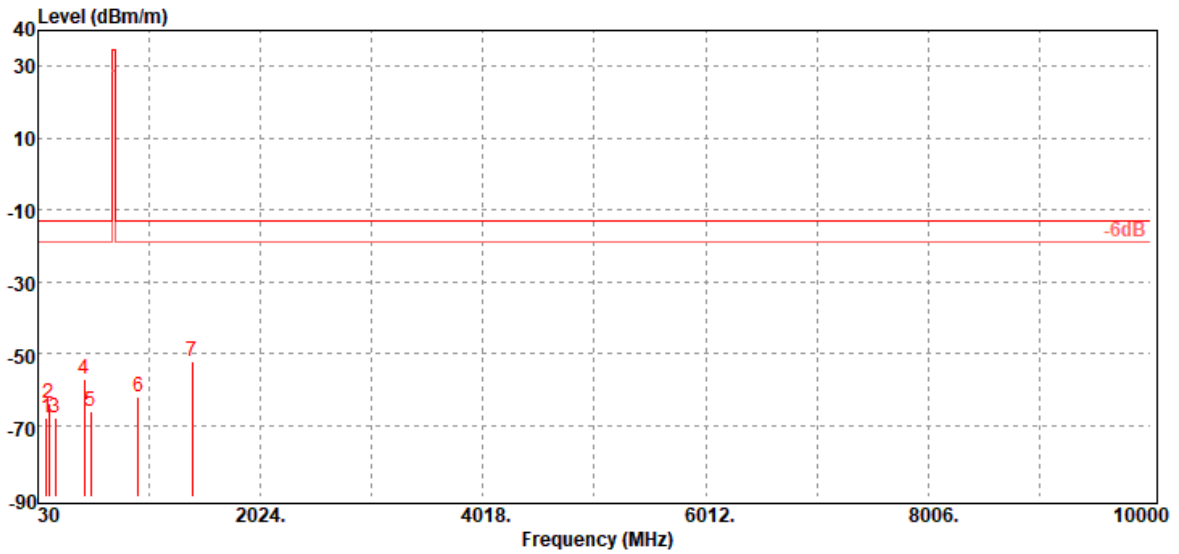

Freq. MHz	ERP/EIRP dBm	SG Output Level dBm	Antenna Gain dBd/dBi	Cable Loss dB	Limit dBm	Margin dB	Antenna Polarization (V/H)
105.66	-67.83	-57.62	-9.37	-0.84	-13.00	-54.83	H
125.06	-63.99	-52.58	-10.49	-0.92	-13.00	-50.99	H
183.26	-67.74	-62.46	-4.17	-1.11	-13.00	-54.74	H
447.10	-57.06	-53.21	-2.10	-1.75	-13.00	-44.06	H
500.45	-66.25	-62.39	-1.99	-1.87	-13.00	-53.25	H
930.16	-61.96	-58.07	-1.30	-2.59	-13.00	-48.96	H
1408.00	-52.17	-56.97	8.05	-3.25	-13.00	-39.17	H

Report No.: T191120D05-RP8

Operation Mode: Tx / Mid CH

Test Date: January 8, 2020

Temperature: 18.6°C

Tested by: Jerry Chang

Humidity: 59% RH

Polarity: Ver.

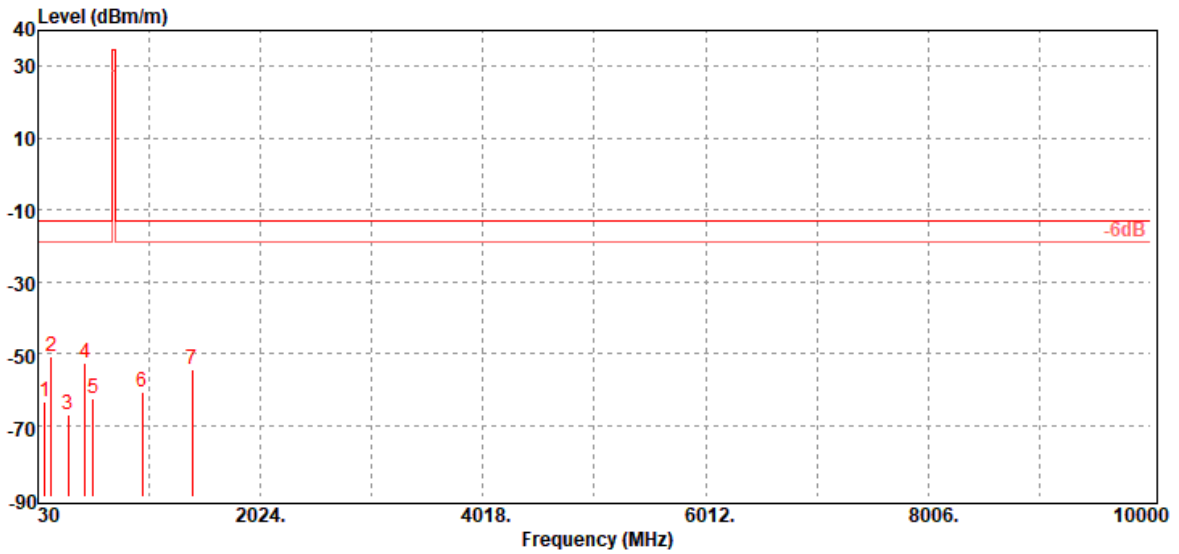

Freq. MHz	ERP/EIRP dBm	SG Output Level dBm	Antenna Gain dBd/dBi	Cable Loss dB	Limit dBm	Margin dB	Antenna Polarization (V/H)
89.17	-63.25	-55.48	-7.00	-0.77	-13.00	-50.25	V
151.25	-50.96	-42.9	-7.05	-1.01	-13.00	-37.96	V
299.66	-67.20	-63.76	-2.01	-1.43	-13.00	-54.20	V
449.04	-52.80	-48.94	-2.10	-1.76	-13.00	-39.80	V
526.64	-62.36	-59.14	-1.30	-1.92	-13.00	-49.36	V
961.20	-60.70	-56.77	-1.30	-2.63	-13.00	-47.70	V
1415.00	-54.50	-59.34	8.09	-3.25	-13.00	-41.50	V

Report No.: T191120D05-RP8

Operation Mode: Tx / Mid CH

Test Date: January 8, 2020

Temperature: 18.6°C

Tested by: Jerry Chang

Humidity: 59% RH

Polarity: Hor.

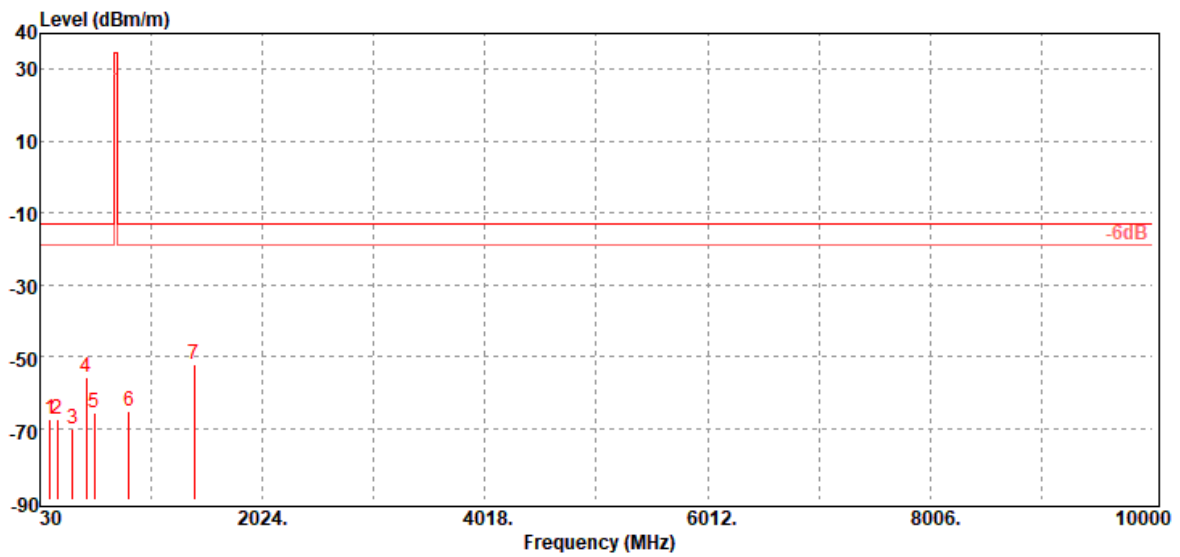

Freq. MHz	ERP/EIRP dBm	SG Output Level dBm	Antenna Gain dBd/dBi	Cable Loss dB	Limit dBm	Margin dB	Antenna Polarization (V/H)
122.15	-67.72	-56.15	-10.67	-0.90	-13.00	-54.72	H
185.20	-67.58	-62.38	-4.08	-1.12	-13.00	-54.58	H
323.91	-70.33	-67.04	-1.80	-1.49	-13.00	-57.33	H
444.19	-55.95	-52.1	-2.10	-1.75	-13.00	-42.95	H
519.85	-65.75	-62.44	-1.40	-1.91	-13.00	-52.75	H
827.34	-65.23	-61.31	-1.50	-2.42	-13.00	-52.23	H
1415.00	-52.24	-57.08	8.09	-3.25	-13.00	-39.24	H

Report No.: T191120D05-RP8

Operation Mode: Tx / High CH

Test Date: January 8, 2020

Temperature: 18.6°C

Tested by: Jerry Chang

Humidity: 59% RH

Polarity: Ver.

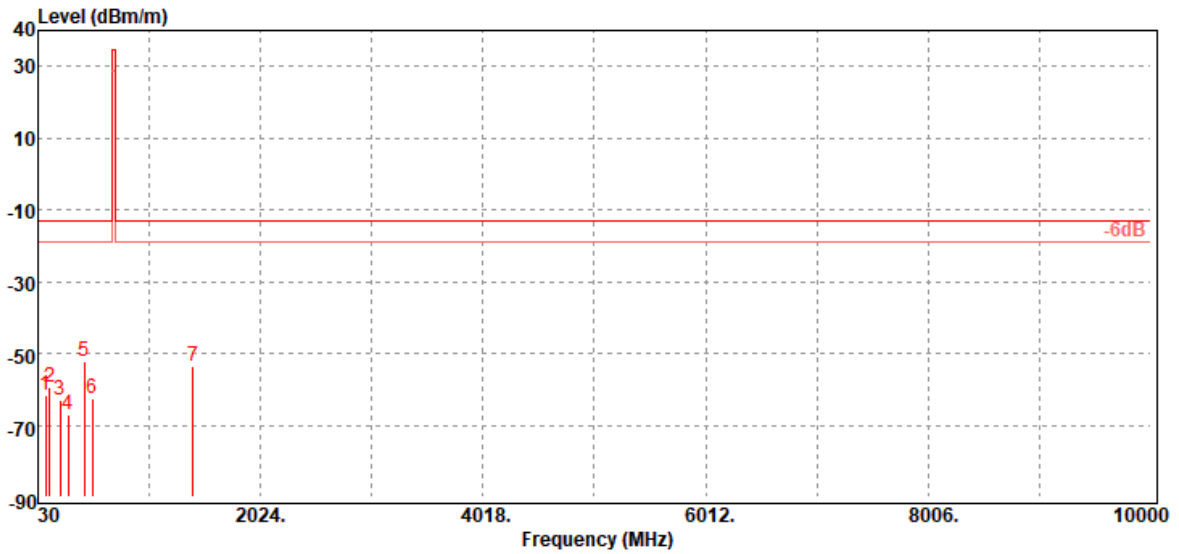

Freq. MHz	ERP/EIRP dBm	SG Output Level dBm	Antenna Gain dBd/dBi	Cable Loss dB	Limit dBm	Margin dB	Antenna Polarization (V/H)
98.87	-61.82	-53.02	-7.99	-0.81	-13.00	-48.82	V
133.79	-59.51	-49.04	-9.52	-0.95	-13.00	-46.51	V
225.94	-63.16	-59.99	-1.94	-1.23	-13.00	-50.16	V
299.66	-66.98	-63.54	-2.01	-1.43	-13.00	-53.98	V
447.10	-52.42	-48.57	-2.10	-1.75	-13.00	-39.42	V
517.91	-62.34	-59	-1.44	-1.90	-13.00	-49.34	V
1422.00	-53.62	-58.49	8.13	-3.26	-13.00	-40.62	V

Report No.: T191120D05-RP8

Operation Mode: Tx / High CH
Temperature: 18.6°C
Humidity: 59% RH

Test Date: January 8, 2020
Tested by: Jerry Chang
Polarity: Hor.

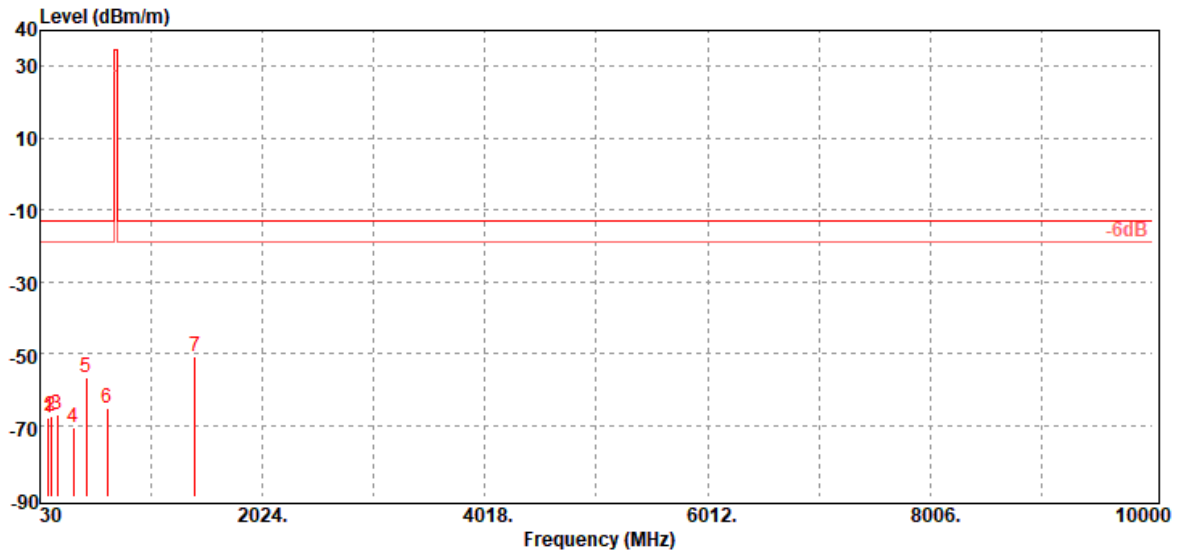

Freq. MHz	ERP/EIRP dBm	SG Output Level dBm	Antenna Gain dBd/dBi	Cable Loss dB	Limit dBm	Margin dB	Antenna Polarization (V/H)
105.66	-68.16	-57.95	-9.37	-0.84	-13.00	-55.16	H
125.06	-67.64	-56.23	-10.49	-0.92	-13.00	-54.64	H
188.11	-67.09	-62.06	-3.90	-1.13	-13.00	-54.09	H
332.64	-70.67	-67.51	-1.65	-1.51	-13.00	-57.67	H
445.16	-56.77	-52.92	-2.10	-1.75	-13.00	-43.77	H
629.46	-65.14	-61.53	-1.49	-2.12	-13.00	-52.14	H
1422.00	-51.08	-55.95	8.13	-3.26	-13.00	-38.08	H

- End of Test Report -