



A D T

FCC TEST REPORT (15.247)

REPORT NO.: RF990901E02

MODEL NO.: SBG6580

FCC ID: W5HSBG6580A

RECEIVED: Aug. 16, 2010

TESTED: Aug. 16 ~ Sep. 13, 2010

ISSUED: Sep. 17, 2010

APPLICANT: GENERAL INSTRUMENT OF TAIWAN, LTD.

ADDRESS: 1, Lane 232 , Pao Chiao Road , Shin Dian,
Taipei, Taiwan 231 , R.O.C.

ISSUED BY: Bureau Veritas Consumer Products Services
(H.K.) Ltd., Taoyuan Branch

LAB ADDRESS: No. 47, 14th Ling, Chia Pau Tsuen, Lin Kou
Hsiang, Taipei Hsien 244, Taiwan, R.O.C.

TEST LOCATION: No. 19, Hwa Ya 2nd Rd, Wen Hwa Tsuen, Kwei
Shan Hsiang, Taoyuan Hsien 333, Taiwan,
R.O.C.

This test report consists of 132 pages in total. It may be duplicated completely for legal use with the approval of the applicant. It should not be reproduced except in full, without the written approval of our laboratory. The client should not use it to claim product, certification, approval or endorsement by TAF or any government agency. The test results in the report only apply to the tested sample.





A D T

TABLE OF CONTENTS

1.	CERTIFICATION.....	5
2.	SUMMARY OF TEST RESULTS	6
2.1	MEASUREMENT UNCERTAINTY	6
3.	GENERAL INFORMATION.....	7
3.1	GENERAL DESCRIPTION OF EUT	7
3.2	DESCRIPTION OF TEST MODES	9
3.2.1	CONFIGURATION OF SYSTEM UNDER TEST	9
3.2.2	TEST MODE APPLICABILITY AND TESTED CHANNEL DETAIL	10
3.3	GENERAL DESCRIPTION OF APPLIED STANDARDS	14
3.4	DESCRIPTION OF SUPPORT UNITS	14
4.	TEST TYPES AND RESULTS (FOR 2.4GHz BAND)	15
4.1	RADIATED EMISSION MEASUREMENT	15
4.1.1	LIMITS OF RADIATED EMISSION MEASUREMENT	15
4.1.2	TEST INSTRUMENTS.....	16
4.1.3	TEST PROCEDURES	17
4.1.4	DEVIATION FROM TEST STANDARD.....	17
4.1.5	TEST SETUP	18
4.1.6	EUT OPERATING CONDITIONS	18
4.1.7	TEST RESULTS	19
4.2	CONDUCTED EMISSION MEASUREMENT	35
4.2.1	LIMITS OF CONDUCTED EMISSION MEASUREMENT	35
4.2.2	TEST INSTRUMENTS.....	35
4.2.3	TEST PROCEDURES	36
4.2.4	DEVIATION FROM TEST STANDARD.....	36
4.2.5	TEST SETUP	37
4.2.6	EUT OPERATING CONDITIONS	37
4.2.7	TEST RESULTS	38
4.3	6dB BANDWIDTH MEASUREMENT	40
4.3.1	LIMITS OF 6dB BANDWIDTH MEASUREMENT	40
4.3.2	TEST INSTRUMENTS.....	40
4.3.3	TEST PROCEDURE.....	40
4.3.4	DEVIATION FROM TEST STANDARD.....	40
4.3.5	TEST SETUP	41
4.3.6	EUT OPERATING CONDITIONS	41
4.3.7	TEST RESULTS	42
4.4	MAXIMUM OUTPUT POWER	47
4.4.1	LIMITS OF MAXIMUM OUTPUT POWER MEASUREMENT.....	47
4.4.2	INSTRUMENTS.....	47
4.4.3	TEST PROCEDURES	47
4.4.4	DEVIATION FROM TEST STANDARD.....	48
4.4.5	TEST SETUP	48
4.4.6	EUT OPERATING CONDITIONS	48
4.4.7	TEST RESULTS	49
4.5	POWER SPECTRAL DENSITY MEASUREMENT.....	50
4.5.1	LIMITS OF POWER SPECTRAL DENSITY MEASUREMENT	50
4.5.2	TEST INSTRUMENTS.....	50
4.5.3	TEST PROCEDURE.....	50
4.5.4	DEVIATION FROM TEST STANDARD.....	51
4.5.5	TEST SETUP	51



4.5.6	EUT OPERATING CONDITION.....	51
4.5.7	TEST RESULTS	52
4.6	BAND EDGES MEASUREMENT	57
4.6.1	LIMITS OF BAND EDGES MEASUREMENT	57
4.6.2	TEST INSTRUMENTS.....	57
4.6.3	TEST PROCEDURE.....	58
4.6.4	DEVIATION FROM TEST STANDARD.....	58
4.6.5	EUT OPERATING CONDITION.....	58
4.6.6	TEST RESULTS	59
5.	TEST TYPES AND RESULTS (FOR 5.0GHz BAND).....	79
5.1	RADIATED EMISSION MEASUREMENT	79
5.1.1	LIMITS OF RADIATED EMISSION MEASUREMENT	79
5.1.2	TEST INSTRUMENTS.....	80
5.1.3	TEST PROCEDURES	81
5.1.4	DEVIATION FROM TEST STANDARD.....	81
5.1.5	TEST SETUP	82
5.1.6	EUT OPERATING CONDITIONS	82
5.1.7	TEST RESULTS	83
5.2	CONDUCTED EMISSION MEASUREMENT	95
5.2.1	LIMITS OF CONDUCTED EMISSION MEASUREMENT	95
5.2.2	TEST INSTRUMENTS.....	95
5.2.3	TEST PROCEDURES	96
5.2.4	DEVIATION FROM TEST STANDARD.....	96
5.2.5	TEST SETUP	97
5.2.6	EUT OPERATING CONDITIONS	97
5.2.7	TEST RESULTS	98
5.3	6dB BANDWIDTH MEASUREMENT.....	100
5.3.1	LIMITS OF 6dB BANDWIDTH MEASUREMENT	100
5.3.2	TEST INSTRUMENTS.....	100
5.3.3	TEST PROCEDURE.....	100
5.3.4	DEVIATION FROM TEST STANDARD.....	101
5.3.5	TEST SETUP.....	101
5.3.6	EUT OPERATING CONDITIONS	101
5.3.7	TEST RESULTS	102
5.4	MAXIMUM OUTPUT POWER	106
5.4.1	LIMITS OF MAXIMUM OUTPUT POWER MEASUREMENT.....	106
5.4.2	INSTRUMENTS.....	106
5.4.3	TEST PROCEDURES	106
5.4.4	DEVIATION FROM TEST STANDARD.....	107
5.4.5	TEST SETUP.....	107
5.4.6	EUT OPERATING CONDITIONS	107
5.4.7	TEST RESULTS	108
5.5	POWER SPECTRAL DENSITY MEASUREMENT	109
5.5.1	LIMITS OF POWER SPECTRAL DENSITY MEASUREMENT	109
5.5.2	TEST INSTRUMENTS.....	109
5.5.3	TEST PROCEDURE.....	109
5.5.4	DEVIATION FROM TEST STANDARD.....	110
5.5.5	TEST SETUP	110
5.5.6	EUT OPERATING CONDITION.....	110
5.5.7	TEST RESULTS	111
5.6	BAND EDGES MEASUREMENT	115
5.6.1	LIMITS OF BAND EDGES MEASUREMENT.....	115



A D T

5.6.2	TEST INSTRUMENTS.....	115
5.6.3	TEST PROCEDURE.....	116
5.6.4	DEVIATION FROM TEST STANDARD.....	117
5.6.5	EUT OPERATING CONDITION.....	117
5.6.6	TEST RESULTS	117
6.	PHOTOGRAPHS OF THE TEST CONFIGURATION.....	130
7.	INFORMATION ON THE TESTING LABORATORIES	131
8.	APPENDIX A - MODIFICATIONS RECORDERS FOR ENGINEERING CHANGES TO THE EUT BY THE LAB	132



A D T

1. CERTIFICATION

PRODUCT: DOCSIS 3.0 Wi-Fi Gateway

MODEL NO.: SBG6580

BRAND: MOTOROLA

APPLICANT: GENERAL INSTRUMENT OF TAIWAN, LTD.

TEST SAMPLE: ENGINEERING SAMPLE

TESTED: Aug. 16 ~ Sep. 13, 2010

STANDARDS: FCC Part 15, Subpart C (Section 15.247)

ANSI C63.4-2003

The above equipment (Model: SBG6580) has been tested by **Bureau Veritas Consumer Products Services (H.K.) Ltd., Taoyuan Branch**, and found compliance with the requirement of the above standards. The test record, data evaluation & Equipment Under Test (EUT) configurations represented herein are true and accurate accounts of the measurements of the sample's EMC characteristics under the conditions specified in this report.

PREPARED BY : Andrea Hsia , **DATE:** Sep. 17, 2010
Andrea Hsia / Specialist

TECHNICAL ACCEPTANCE : Long Chen , **DATE:** Sep. 17, 2010
Responsible for RF Long Chen / Senior Engineer

APPROVED BY : Gary Chang , **DATE:** Sep. 17, 2010
Gary Chang / Assistant Manager



2. SUMMARY OF TEST RESULTS

The EUT has been tested according to the following specifications:

APPLIED STANDARD: FCC PART 15, SUBPART C (SECTION 15.247)			
STANDARD SECTION	TEST TYPE AND LIMIT	RESULT	REMARK
15.207	AC Power Conducted Emission	PASS	Meet the requirement of limit. Minimum passing margin is -10.04dB at 20.758MHz
15.247(a)(2)	Spectrum Bandwidth of a Direct Sequence Spread Spectrum System Limit: min. 500kHz	PASS	Meet the requirement of limit.
15.247(b)	Maximum Peak Output Power Limit: max. 30dBm	PASS	Meet the requirement of limit.
15.247(d)	Radiated Emissions Limit: Table 15.209	PASS	Meet the requirement of limit. Minimum passing margin is -1.0dB at 2390.00 & 2500.00MHz
15.247(e)	Power Spectral Density Limit: max. 8dBm	PASS	Meet the requirement of limit.
15.247(d)	Band Edge Measurement Limit: 20dB less than the peak value of fundamental frequency	PASS	Meet the requirement of limit.
15.203	Antenna Requirement	PASS	Antenna connector is UFL not a standard connector.

2.1 MEASUREMENT UNCERTAINTY

Where relevant, the following measurement uncertainty levels have been estimated for tests performed on the EUT as specified in CISPR 16-4-2:

MEASUREMENT	FREQUENCY	UNCERTAINTY
Conducted emissions	9kHz~30MHz	2.44 dB
Radiated emissions	30MHz ~ 200MHz	2.93 dB
	200MHz ~1000MHz	2.95 dB
	1GHz ~ 18GHz	2.26 dB
	18GHz ~ 40GHz	1.94 dB

This uncertainty represents an expanded uncertainty expressed at approximately the 95% confidence level using a coverage factor of k = 2.



3. GENERAL INFORMATION

3.1 GENERAL DESCRIPTION OF EUT

PRODUCT	DOCSIS 3.0 Wi-Fi Gateway
MODEL NO.	SBG6580
FCC ID	W5HSBG6580A
NOMINAL VOLTAGE	12Vdc
MODULATION TYPE	CCK, DQPSK, DBPSK for DSSS 64QAM, 16QAM, QPSK, BPSK for OFDM
MODULATION TECHNOLOGY	DSSS, OFDM
TRANSFER RATE	802.11b: 11.0/ 5.5/ 2.0/ 1.0Mbps 802.11g: 54.0/ 48.0/ 36.0/ 24.0/ 18.0/ 12.0/ 9.0/ 6.0Mbps 802.11a: 54.0/ 48.0/ 36.0/ 24.0/ 18.0/ 12.0/ 9.0/ 6.0Mbps 802.11n: up to 300.0Mbps
OPERATING FREQUENCY	2.4GHz: 2412.0 ~ 2462.0MHz 5.0GHz: 5745.0 ~ 5825.0MHz
NUMBER OF CHANNEL	2.4GHz: 11 for 802.11b, 802.11g, 802.11n (20MHz) 7 for 802.11n (40MHz) 5.0GHz: 5 for 802.11a, 802.11n (20MHz) 2 for 802.11n (40MHz)
OUTPUT POWER	300.2mW for 2412.0 ~ 2462.0MHz 356.5mW for 5745.0 ~ 5825.0MHz
ANTENNA TYPE	2.4GHz: Printed antenna with 3.5dBi gain (Antenna A) Printed antenna with 5.2dBi gain (Antenna B) 5.0GHz: Printed antenna with 4.0dBi gain (Antenna A) Printed antenna with 5.5dBi gain (Antenna B)
ANTENNA CONNECTOR	UFL
DATA CABLE	1.8m non-shielded RJ45 cable without core 1.5m non-shielded Diag cable without core
I/O PORTS	Refer to User's manual
ASSOCIATED DEVICES	Adapter

NOTE:

- The EUT is a DOCSIS 3.0 Wi-Fi Gateway. The test data are separated into following test reports.

	TEST STANDARD	REFERENCE REPORT
WLAN 802.11b/g, 802.11n	FCC Part 15, Subpart C (Section 15.247)	RF990901E02
WLAN 802.11a, 802.11n (5745~5825 MHz)		
WLAN 802.11a, 802.11n (5180~ 5240MHz)	FCC Part 15, Subpart E (Section 15.407)	RF990901E02-1

2. The frequency bands used in this EUT are listed as follows:

Frequency Band (MHz)	2412~2462	5180~5240	5745~5825
802.11b	√		
802.11g	√		
802.11a		√	√
802.11n (20MHz)	√	√	√
802.11n (40MHz)	√	√	√

3. The EUT incorporates a MIMO function. Physically, the EUT provides two completed transmitters and two receivers.

MODULATION MODE	TX FUNCTION	TX ANTENNA
802.11b	1TX	Only Ant A
802.11g	1TX	Ant A or B
802.11a	1TX	Ant A or B
802.11n (20MHz)	2TX	2 TX : Ant A & B
802.11n (40MHz)	2TX	2 TX : Ant A & B

4. The EUT was powered by the following adapter:

BRAND:	DELTA
MODEL:	EADP-24MB A
INPUT:	100-240Vac, 50-60Hz, 0.6A
OUTPUT:	12Vdc, 2A
POWER LINE:	AC 1.8m non-shielded cable without core DC 1.5m non-shielded cable without core

5. The above EUT information was declared by manufacturer and for more detailed features description, please refer to the manufacturer's specifications or user's manual.

3.2 DESCRIPTION OF TEST MODES

FOR 2.4GHz:

11 channels are provided for 802.11b, 802.11g and 802.11n (20MHz):

CHANNEL	FREQUENCY	CHANNEL	FREQUENCY
1	2412MHz	7	2442MHz
2	2417MHz	8	2447MHz
3	2422MHz	9	2452MHz
4	2427MHz	10	2457MHz
5	2432MHz	11	2462MHz
6	2437MHz		

7 channels are provided for 802.11n (40MHz):

CHANNEL	FREQUENCY	CHANNEL	FREQUENCY
1	2422MHz	5	2442MHz
2	2427MHz	6	2447MHz
3	2432MHz	7	2452MHz
4	2437MHz		

FOR 5.0GHz (5725 ~ 5850MHz):

5 channels are provided for 802.11a and 802.11n (20MHz):

CHANNEL	FREQUENCY	CHANNEL	FREQUENCY
149	5745MHz	161	5805MHz
153	5765MHz	165	5825MHz
157	5785MHz		

2 channels are provided for 802.11n (40MHz):

CHANNEL	FREQUENCY	CHANNEL	FREQUENCY
151	5755MHz	159	5795MHz

3.2.1 CONFIGURATION OF SYSTEM UNDER TEST

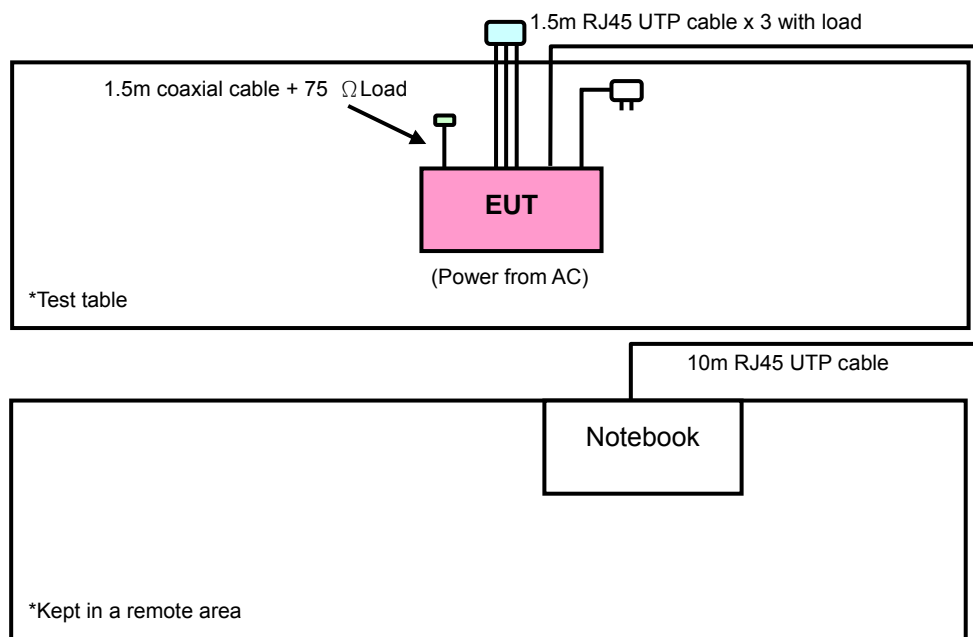



A D T

3.2.2 TEST MODE APPLICABILITY AND TESTED CHANNEL DETAIL

FOR 2.400 ~ 2.4835GHz:

EUT CONFIGURE MODE	APPLICABLE TO				DESCRIPTION
	RE \geq 1G	RE<1G	PLC	APCM	
-	√	√	√	√	-

Where **RE \geq 1G**: Radiated Emission above 1GHz **RE<1G**: Radiated Emission below 1GHz
PLC: Power Line Conducted Emission **APCM**: Antenna Port Conducted Measurement

RADIATED EMISSION TEST (ABOVE 1GHz):

- Pre-Scan has been conducted to determine the worst-case mode from all possible combinations between available modulations, data rates, XYZ axis and antenna ports (if EUT with antenna diversity architecture).
- Following channel(s) was (were) selected for the final test as listed below.

MODE	AVAILABLE CHANNEL	TESTED CHANNEL	MODULATION TECHNOLOGY	MODULATION TYPE	DATA RATE (Mbps)	AXIS	ANT.
802.11b	1 to 11	1, 6, 11	DSSS	DBPSK	1.0	Z	A
802.11g	1 to 11	1, 6, 11	OFDM	BPSK	6.0	Z	A
802.11g	1 to 11	1, 6, 11	OFDM	BPSK	6.0	Z	B
802.11n (20MHz)	1 to 11	1, 6, 11	OFDM	BPSK	7.2	Z	A+B
802.11n (40MHz)	1 to 7	1, 4, 7	OFDM	BPSK	15.0	Z	A+B

RADIATED EMISSION TEST (BELOW 1GHz):

- Pre-Scan has been conducted to determine the worst-case mode from all possible combinations between available modulations, data rates, XYZ axis and antenna ports (if EUT with antenna diversity architecture).
- Following channel(s) was (were) selected for the final test as listed below.

MODE	AVAILABLE CHANNEL	TESTED CHANNEL	MODULATION TECHNOLOGY	MODULATION TYPE	DATA RATE (Mbps)	AXIS
802.11n (20MHz)	1 to 11	6	OFDM	BPSK	7.2	Z

POWER LINE CONDUCTED EMISSION TEST:

- Pre-Scan has been conducted to determine the worst-case mode from all possible combinations between available modulations, data rates and antenna ports (if EUT with antenna diversity architecture).
- Following channel(s) was (were) selected for the final test as listed below.

MODE	AVAILABLE CHANNEL	TESTED CHANNEL	MODULATION TECHNOLOGY	MODULATION TYPE	DATA RATE (Mbps)
802.11n (20MHz)	1 to 11	6	OFDM	BPSK	7.2



BANDEDGE MEASUREMENT:

- Pre-Scan has been conducted to determine the worst-case mode from all possible combinations between available modulations, data rates and antenna ports (if EUT with antenna diversity architecture).
- Following channel(s) was (were) selected for the final test as listed below.

MODE	AVAILABLE CHANNEL	TESTED CHANNEL	MODULATION TECHNOLOGY	MODULATION TYPE	DATA RATE (Mbps)	ANT.
802.11b	1 to 11	1,11	DSSS	DBPSK	1.0	A
802.11g	1 to 11	1, 11	OFDM	BPSK	6.0	A
802.11g	1 to 11	1, 11	OFDM	BPSK	6.0	B
802.11n (20MHz)	1 to 11	1, 11	OFDM	BPSK	7.2	A+B
802.11n (40MHz)	1 to 7	1, 7	OFDM	BPSK	15.0	A+B

ANTENNA PORT CONDUCTED MEASUREMENT:

- This item includes all test value of each mode, but only includes spectrum plot of worst value of each mode.
- Pre-Scan has been conducted to determine the worst-case mode from all possible combinations between available modulations, data rates and antenna ports (if EUT with antenna diversity architecture).
- Following channel(s) was (were) selected for the final test as listed below.

MODE	AVAILABLE CHANNEL	TESTED CHANNEL	MODULATION TECHNOLOGY	MODULATION TYPE	DATA RATE (Mbps)	ANT.
802.11b	1 to 11	1, 6, 11	DSSS	DBPSK	1.0	A
802.11g	1 to 11	1, 6, 11	OFDM	BPSK	6.0	A
802.11g	1 to 11	1, 6, 11	OFDM	BPSK	6.0	B
802.11n (20MHz)	1 to 11	1, 6, 11	OFDM	BPSK	7.2	A+B
802.11n (40MHz)	1 to 7	1, 4, 7	OFDM	BPSK	15.0	A+B

TEST CONDITION:

APPLICABLE TO	ENVIRONMENTAL CONDITIONS	INPUT POWER	TESTED BY
RE \geq 1G	25deg. C, 65%RH, 1020 hPa	120Vac, 60Hz	Brad Wu, Sun Lin
RE $<$ 1G	25deg. C, 65%RH, 1008 hPa	120Vac, 60Hz	Brad Wu
PLC	20deg. C, 60%RH, 1020 hPa	120Vac, 60Hz	Match Tsui
APCM	25deg. C, 65%RH, 1020 hPa	120Vac, 60Hz	Brad Wu



A D T

FOR 5.725 ~ 5.850GHz:

EUT CONFIGURE MODE	APPLICABLE TO				DESCRIPTION
	RE≥1G	RE<1G	PLC	APCM	
-	√	√	√	√	-

Where **RE≥1G**: Radiated Emission above 1GHz **RE<1G**: Radiated Emission below 1GHz
PLC: Power Line Conducted Emission **APCM**: Antenna Port Conducted Measurement

RADIATED EMISSION TEST (ABOVE 1GHz):

- Pre-Scan has been conducted to determine the worst-case mode from all possible combinations between available modulations, data rates, XYZ axis and antenna ports (if EUT with antenna diversity architecture).
- Following channel(s) was (were) selected for the final test as listed below.

MODE	AVAILABLE CHANNEL	TESTED CHANNEL	MODULATION TECHNOLOGY	MODULATION TYPE	DATA RATE (Mbps)	AXIS	ANT.
802.11a	149 to 165	149, 157, 165	OFDM	BPSK	6.0	Z	A
802.11a	149 to 165	149, 157, 165	OFDM	BPSK	6.0	Z	B
802.11n (20MHz)	149 to 165	149, 157, 165	OFDM	BPSK	7.2	Z	A+B
802.11n (40MHz)	151 to 159	151, 159	OFDM	BPSK	15.0	Z	A+B

RADIATED EMISSION TEST (BELOW 1GHz):

- Pre-Scan has been conducted to determine the worst-case mode from all possible combinations between available modulations, data rates, XYZ axis and antenna ports (if EUT with antenna diversity architecture).
- Following channel(s) was (were) selected for the final test as listed below.

MODE	AVAILABLE CHANNEL	TESTED CHANNEL	MODULATION TECHNOLOGY	MODULATION TYPE	DATA RATE (Mbps)	AXIS	ANT.
802.11n (20MHz)	149 to 165	157	OFDM	BPSK	7.2	Z	A+B

POWER LINE CONDUCTED EMISSION TEST:

- Pre-Scan has been conducted to determine the worst-case mode from all possible combinations between available modulations, data rates and antenna ports (if EUT with antenna diversity architecture).
- Following channel(s) was (were) selected for the final test as listed below.

MODE	AVAILABLE CHANNEL	TESTED CHANNEL	MODULATION TECHNOLOGY	MODULATION TYPE	DATA RATE (Mbps)	ANT.
802.11n (20MHz)	149 to 165	157	OFDM	BPSK	7.2	A+B



BANDEDGE MEASUREMENT:

- Pre-Scan has been conducted to determine the worst-case mode from all possible combinations between available modulations, data rates and antenna ports (if EUT with antenna diversity architecture).
- Following channel(s) was (were) selected for the final test as listed below.

MODE	AVAILABLE CHANNEL	TESTED CHANNEL	MODULATION TECHNOLOGY	MODULATION TYPE	DATA RATE (Mbps)	ANT.
802.11a	149 to 165	149, 165	OFDM	BPSK	6.0	A
802.11a	149 to 165	149, 165	OFDM	BPSK	6.0	B
802.11n (20MHz)	149 to 165	149, 165	OFDM	BPSK	7.2	A+B
802.11n (40MHz)	151 to 159	151, 159	OFDM	BPSK	15.0	A+B

ANTENNA PORT CONDUCTED MEASUREMENT:

- This item includes all test value of each mode, but only includes spectrum plot of worst value of each mode.
- Pre-Scan has been conducted to determine the worst-case mode from all possible combinations between available modulations, data rates and antenna ports (if EUT with antenna diversity architecture).
- Following channel(s) was (were) selected for the final test as listed below.

MODE	AVAILABLE CHANNEL	TESTED CHANNEL	MODULATION TECHNOLOGY	MODULATION TYPE	DATA RATE (Mbps)	ANT.
802.11a	149 to 165	149, 157, 165	OFDM	BPSK	6.0	A
802.11a	149 to 165	149, 157, 165	OFDM	BPSK	6.0	B
802.11n (20MHz)	149 to 165	149, 157, 165	OFDM	BPSK	7.2	A+B
802.11n (40MHz)	151 to 159	151, 159	OFDM	BPSK	15.0	A+B

TEST CONDITION:

APPLICABLE TO	ENVIRONMENTAL CONDITIONS	INPUT POWER	TESTED BY
RE≥1G	25deg. C, 65%RH, 1020 hPa	120Vac, 60Hz	Brad Wu, Sun Lin
RE<1G	25deg. C, 65%RH, 1008 hPa	120Vac, 60Hz	Brad Wu
PLC	20deg. C, 60%RH, 1020 hPa	120Vac, 60Hz	Match Tsui
APCM	25deg. C, 65%RH, 1020 hPa	120Vac, 60Hz	Brad Wu



A D T

3.3 GENERAL DESCRIPTION OF APPLIED STANDARDS

The EUT is a RF Product. According to the specifications of the manufacturer, it must comply with the requirements of the following standards:

FCC Part 15, Subpart C (15.247)

ANSI C63.4-2003

All test items have been performed and recorded as per the above standards.

NOTE: The EUT is also considered as a kind of computer peripheral, because the connection to computer is necessary for typical use. It has been verified to comply with the requirements of FCC Part 15, Subpart B, Class B (DoC). The test report has been issued separately.

3.4 DESCRIPTION OF SUPPORT UNITS

The EUT has been tested as an independent unit together with other necessary accessories or support units. The following support units or accessories were used to form a representative test configuration during the tests.

NO.	PRODUCT	BRAND	MODEL NO.	SERIAL NO.	FCC ID
1	NOTEBOOK	DELL	D531	CN-0XM006-48643-81U-2973	QDS-BRCM1020

NO.	SIGNAL CABLE DESCRIPTION OF THE ABOVE SUPPORT UNITS
1	10m RJ45 UTP cable

NOTE: All power cords of the above support units are non shielded (1.8m).



4. TEST TYPES AND RESULTS (FOR 2.4GHz BAND)

4.1 RADIATED EMISSION MEASUREMENT

4.1.1 LIMITS OF RADIATED EMISSION MEASUREMENT

Emissions radiated outside of the specified bands, shall be according to the general radiated limits in 15.209 as following:

FREQUENCIES (MHz)	FIELD STRENGTH (microvolts/meter)	MEASUREMENT DISTANCE (meters)
0.009 ~ 0.490	2400/F(kHz)	300
0.490 ~ 1.705	24000/F(kHz)	30
1.705 ~ 30.0	30	30
30 ~ 88	100	3
88 ~ 216	150	3
216 ~ 960	200	3
Above 960	500	3

NOTE:

1. The lower limit shall apply at the transition frequencies.
2. Emission level (dBuV/m) = 20 log Emission level (uV/m).
3. As shown in 15.35(b), for frequencies above 1000MHz, the field strength limits are based on average detector, however, the peak field strength of any emission shall not exceed the maximum permitted average limits, specified above by more than 20dB under any condition of modulation.



A D T

4.1.2 TEST INSTRUMENTS

DESCRIPTION & MANUFACTURER	MODEL NO.	SERIAL NO.	DATE OF CALIBRATION	DUE DATE OF CALIBRATION
Test Receiver ROHDE & SCHWARZ	ESIB7	100188	Dec. 21, 2009	Dec. 20, 2010
Spectrum Analyzer ROHDE & SCHWARZ	FSP40	100041	Jul. 09, 2010	Jul. 08, 2011
BILOG Antenna SCHWARZBECK	VULB9168	9168-156	Apr. 30, 2010	Apr. 29, 2011
HORN Antenna SCHWARZBECK	BBHA 9120 D	9120D-209	Aug. 02, 2010	Aug. 01, 2011
HORN Antenna SCHWARZBECK	BBHA 9170	BBHA9170242	Dec. 25, 2009	Dec. 24, 2010
Preamplifier Agilent	8447D	2944A10629	Nov. 04, 2009	Nov. 03, 2010
Preamplifier Agilent	8449B	3008A01959	Dec. 10, 2009	Dec. 09, 2010
RF signal cable HUBER+SUHNNER	SUCOFLEX 104	238141/4	May 14, 2010	May 13, 2011
RF signal cable HUBER+SUHNNER	SUCOFLEX 104	12738/6	May 14, 2010	May 13, 2011
Software	ADT_Radiated_ V7.6.15.9.2	NA	NA	NA
Antenna Tower EMCO	2070/2080	512.835.4684	NA	NA
Turn Table EMCO	2087-2.03	NA	NA	NA
Antenna Tower & Turn Table Controller EMCO	2090	NA	NA	NA

- NOTE:**
1. The calibration interval of the above test instruments is 12 months and the calibrations are traceable to NML/ROC and NIST/USA.
 2. The test was performed in HwaYa Chamber 9.
 3. The horn antenna and HP preamplifier (model: 8449B) are used only for the measurement of emission frequency above 1GHz if tested.
 4. The FCC Site Registration No. is 460141.
 5. The IC Site Registration No. is IC 7450F-4.



4.1.3 TEST PROCEDURES

- a. The EUT was placed on the top of a rotating table 0.8 meters above the ground at a 3 meters semi-anechoic chamber. The table was rotated 360 degrees to determine the position of the highest radiation.
- b. The EUT was set 3 meters away from the interference-receiving antenna, which was mounted on the top of a variable-height antenna tower.
- c. The antenna is a broadband antenna, and its height is varied from one meter to four meters above the ground to determine the maximum value of the field strength. Both horizontal and vertical polarizations of the antenna are set to make the measurement.
- d. For each suspected emission, the EUT was arranged to its worst case and then the antenna was tuned to heights from 1 meter to 4 meters and the rotatable table was turned from 0 degrees to 360 degrees to find the maximum reading.
- e. The test-receiver system was set to Peak Detect Function and Specified Bandwidth with Maximum Hold Mode.
- f. If the emission level of the EUT in peak mode was lower than the limit specified, then testing could be stopped and the peak values of the EUT would be reported. Otherwise the emissions would be re-tested one by one using peak, quasi-peak or average method as specified and then reported in a data sheet.

NOTE:

1. The resolution bandwidth and video bandwidth of test receiver/spectrum analyzer is 120kHz for Quasi-peak detection at frequency below 1GHz.
2. The resolution bandwidth of test receiver/spectrum analyzer is 100kHz and video bandwidth is 300kHz for Peak detection at frequency above 1GHz.
3. The resolution bandwidth of test receiver/spectrum analyzer is 1MHz and the video bandwidth is 10Hz for Average detection (AV) at frequency above 1GHz.
4. All modes of operation were investigated and the worst-case emissions are reported.

4.1.4 DEVIATION FROM TEST STANDARD

No deviation

4.1.5 TEST SETUP

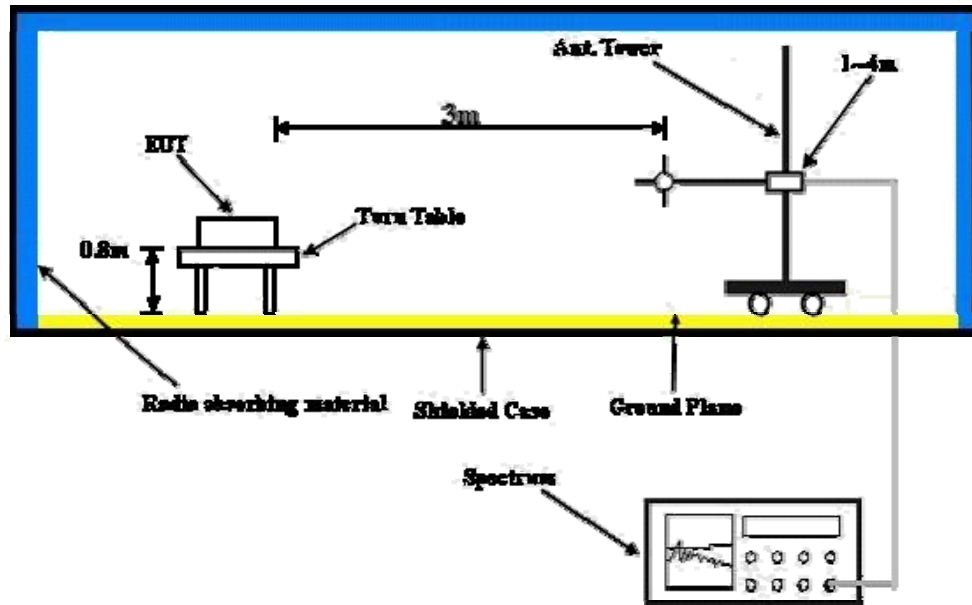

For the actual test configuration, please refer to the attached file (Test Setup Photo).

4.1.6 EUT OPERATING CONDITIONS

- a. Placed the EUT on the testing table.
- b. Prepared notebook system outside of testing area to act as a communication partner.
- c. The communication partner connected with EUT via a RJ45 cable and run a test program (provided by manufacturer) to enable EUT under transmission condition continuously at specific channel frequency.
- d. The communication partner sent data to EUT by command "PING".



A D T

4.1.7 TEST RESULTS

802.11b

EUT TEST CONDITION		MEASUREMENT DETAIL	
CHANNEL	Channel 1	FREQUENCY RANGE	1 ~ 25GHz
INPUT POWER (SYSTEM)	120Vac, 60 Hz	DETECTOR FUNCTION	Peak (PK) Average (AV)
ENVIRONMENTAL CONDITIONS	25deg. C, 65%RH 1020 hPa	TESTED BY	Brad Wu

ANTENNA POLARITY & TEST DISTANCE: HORIZONTAL AT 3 M								
NO.	FREQ. (MHz)	EMISSION LEVEL (dBuV/m)	LIMIT (dBuV/m)	MARGIN (dB)	ANTENNA HEIGHT (m)	TABLE ANGLE (Degree)	RAW VALUE (dBuV)	CORRECTION FACTOR (dB/m)
1	2390.00	57.5 PK	74.0	-16.5	1.16 H	2	25.20	32.30
2	2390.00	46.8 AV	54.0	-7.2	1.16 H	2	14.50	32.30
3	*2412.00	107.0 PK			1.16 H	2	74.60	32.40
4	*2412.00	102.9 AV			1.16 H	2	70.50	32.40
5	2500.00	60.8 PK	74.0	-13.2	1.14 H	358	28.10	32.70
6	2500.00	53.0 AV	54.0	-1.0	1.14 H	358	20.30	32.70
7	4824.00	49.0 PK	74.0	-25.0	1.00 H	111	10.60	38.40
8	4824.00	42.8 AV	54.0	-11.2	1.00 H	111	4.40	38.40
9	5000.00	52.2 PK	74.0	-21.8	1.28 H	70	13.40	38.80
10	5000.00	47.4 AV	54.0	-6.6	1.28 H	70	8.60	38.80
ANTENNA POLARITY & TEST DISTANCE: VERTICAL AT 3 M								
NO.	FREQ. (MHz)	EMISSION LEVEL (dBuV/m)	LIMIT (dBuV/m)	MARGIN (dB)	ANTENNA HEIGHT (m)	TABLE ANGLE (Degree)	RAW VALUE (dBuV)	CORRECTION FACTOR (dB/m)
1	2390.00	56.3 PK	74.0	-17.7	1.25 V	98	24.00	32.30
2	2390.00	45.9 AV	54.0	-8.1	1.25 V	98	13.60	32.30
3	*2412.00	105.8 PK			1.25 V	98	73.40	32.40
4	*2412.00	101.6 AV			1.25 V	98	69.20	32.40
5	2500.00	60.5 PK	74.0	-13.5	1.00 V	176	27.80	32.70
6	2500.00	52.7 AV	54.0	-1.3	1.00 V	176	20.00	32.70
7	4824.00	47.7 PK	74.0	-26.3	1.41 V	162	9.30	38.40
8	4824.00	39.8 AV	54.0	-14.2	1.41 V	162	1.40	38.40
9	5000.00	52.6 PK	74.0	-21.4	1.05 V	149	13.80	38.80
10	5000.00	48.9 AV	54.0	-5.1	1.05 V	149	10.10	38.80

- REMARKS:**
1. Emission level (dBuV/m) = Raw Value (dBuV) + Correction Factor (dB/m).
 2. Correction Factor (dB/m) = Antenna Factor (dB/m) + Cable Factor (dB).
 3. The other emission levels were very low against the limit.
 4. Margin value = Emission level – Limit value.
 5. “ * “: Fundamental frequency.



A D T

EUT TEST CONDITION		MEASUREMENT DETAIL	
CHANNEL	Channel 6	FREQUENCY RANGE	1 ~ 25GHz
INPUT POWER (SYSTEM)	120Vac, 60 Hz	DETECTOR FUNCTION	Peak (PK) Average (AV)
ENVIRONMENTAL CONDITIONS	25deg. C, 65%RH 1020 hPa	TESTED BY	Brad Wu

ANTENNA POLARITY & TEST DISTANCE: HORIZONTAL AT 3 M								
NO.	FREQ. (MHz)	EMISSION LEVEL (dBuV/m)	LIMIT (dBuV/m)	MARGIN (dB)	ANTENNA HEIGHT (m)	TABLE ANGLE (Degree)	RAW VALUE (dBuV)	CORRECTION FACTOR (dB/m)
1	*2437.00	106.6 PK			1.14 H	358	74.20	32.40
2	*2437.00	102.4 AV			1.14 H	358	70.00	32.40
3	2500.00	60.7 PK	74.0	-13.3	1.14 H	359	28.00	32.70
4	2500.00	52.7 AV	54.0	-1.3	1.14 H	359	20.00	32.70
5	4874.00	51.0 PK	74.0	-23.0	1.25 H	104	12.50	38.50
6	4874.00	47.1 AV	54.0	-6.9	1.25 H	104	8.60	38.50
7	5000.00	52.5 PK	74.0	-21.5	1.27 H	107	13.70	38.80
8	5000.00	49.1 AV	54.0	-4.9	1.27 H	107	10.30	38.80
ANTENNA POLARITY & TEST DISTANCE: VERTICAL AT 3 M								
NO.	FREQ. (MHz)	EMISSION LEVEL (dBuV/m)	LIMIT (dBuV/m)	MARGIN (dB)	ANTENNA HEIGHT (m)	TABLE ANGLE (Degree)	RAW VALUE (dBuV)	CORRECTION FACTOR (dB/m)
1	*2437.00	105.4 PK			1.26 V	96	73.00	32.40
2	*2437.00	101.2 AV			1.26 V	96	68.80	32.40
3	2500.00	60.2 PK	74.0	-13.8	1.01 V	180	27.50	32.70
4	2500.00	52.4 AV	54.0	-1.6	1.01 V	180	19.70	32.70
5	4874.00	49.8 PK	74.0	-24.2	1.21 V	100	11.30	38.50
6	4874.00	45.5 AV	54.0	-8.5	1.21 V	100	7.00	38.50
7	5000.00	49.9 PK	74.0	-24.1	1.01 V	129	11.10	38.80
8	5000.00	45.2 AV	54.0	-8.8	1.01 V	129	6.40	38.80

- REMARKS:**
1. Emission level (dBuV/m) = Raw Value (dBuV) + Correction Factor (dB/m).
 2. Correction Factor (dB/m) = Antenna Factor (dB/m) + Cable Factor (dB).
 3. The other emission levels were very low against the limit.
 4. Margin value = Emission level – Limit value.
 5. “ * “: Fundamental frequency.



A D T

EUT TEST CONDITION		MEASUREMENT DETAIL	
CHANNEL	Channel 11	FREQUENCY RANGE	1 ~ 25GHz
INPUT POWER (SYSTEM)	120Vac, 60 Hz	DETECTOR FUNCTION	Peak (PK) Average (AV)
ENVIRONMENTAL CONDITIONS	25deg. C, 65%RH 1020 hPa	TESTED BY	Brad Wu

ANTENNA POLARITY & TEST DISTANCE: HORIZONTAL AT 3 M								
NO.	FREQ. (MHz)	EMISSION LEVEL (dBuV/m)	LIMIT (dBuV/m)	MARGIN (dB)	ANTENNA HEIGHT (m)	TABLE ANGLE (Degree)	RAW VALUE (dBuV)	CORRECTION FACTOR (dB/m)
1	*2462.00	106.8 PK			1.14 H	10	74.30	32.50
2	*2462.00	102.6 AV			1.14 H	10	70.10	32.50
3	2483.50	58.5 PK	74.0	-15.5	1.14 H	10	25.90	32.60
4	2483.50	48.6 AV	54.0	-5.4	1.14 H	10	16.00	32.60
5	2500.00	61.2 PK	74.0	-12.8	1.11 H	2	28.50	32.70
6	2500.00	52.6 AV	54.0	-1.4	1.11 H	2	19.90	32.70
7	4924.00	50.4 PK	74.0	-23.6	1.08 H	112	11.80	38.60
8	4924.00	45.4 AV	54.0	-8.6	1.08 H	112	6.80	38.60
9	5000.00	52.5 PK	74.0	-21.5	1.25 H	105	13.70	38.80
10	5000.00	48.8 AV	54.0	-5.2	1.25 H	105	10.00	38.80
ANTENNA POLARITY & TEST DISTANCE: VERTICAL AT 3 M								
NO.	FREQ. (MHz)	EMISSION LEVEL (dBuV/m)	LIMIT (dBuV/m)	MARGIN (dB)	ANTENNA HEIGHT (m)	TABLE ANGLE (Degree)	RAW VALUE (dBuV)	CORRECTION FACTOR (dB/m)
1	*2462.00	105.5 PK			1.25 V	95	73.00	32.50
2	*2462.00	101.3 AV			1.25 V	95	68.80	32.50
3	2483.50	56.9 PK	74.0	-17.1	1.25 V	95	24.30	32.60
4	2483.50	46.6 AV	54.0	-7.4	1.25 V	95	14.00	32.60
5	2500.00	60.0 PK	74.0	-14.0	1.02 V	181	27.30	32.70
6	2500.00	52.3 AV	54.0	-1.7	1.02 V	181	19.60	32.70
7	4924.00	49.2 PK	74.0	-24.8	1.05 V	116	10.60	38.60
8	4924.00	44.9 AV	54.0	-9.1	1.05 V	116	6.30	38.60
9	5000.00	50.2 PK	74.0	-23.8	1.02 V	131	11.40	38.80
10	5000.00	45.4 AV	54.0	-8.6	1.02 V	131	6.60	38.80

- REMARKS:**
1. Emission level (dBuV/m) = Raw Value (dBuV) + Correction Factor (dB/m).
 2. Correction Factor (dB/m) = Antenna Factor (dB/m) + Cable Factor (dB).
 3. The other emission levels were very low against the limit.
 4. Margin value = Emission level – Limit value.
 5. “ * ”: Fundamental frequency.



A D T

802.11g (Antenna A)

EUT TEST CONDITION		MEASUREMENT DETAIL	
CHANNEL	Channel 1	FREQUENCY RANGE	1 ~ 25GHz
INPUT POWER (SYSTEM)	120Vac, 60 Hz	DETECTOR FUNCTION	Peak (PK) Average (AV)
ENVIRONMENTAL CONDITIONS	25deg. C, 65%RH 1020 hPa	TESTED BY	Brad Wu

ANTENNA POLARITY & TEST DISTANCE: HORIZONTAL AT 3 M

NO.	FREQ. (MHz)	EMISSION LEVEL (dBuV/m)	LIMIT (dBuV/m)	MARGIN (dB)	ANTENNA HEIGHT (m)	TABLE ANGLE (Degree)	RAW VALUE (dBuV)	CORRECTION FACTOR (dB/m)
1	2390.00	71.9 PK	74.0	-2.1	1.18 H	1	39.60	32.30
2	2390.00	52.6 AV	54.0	-1.4	1.18 H	1	20.30	32.30
3	*2412.00	106.3 PK			1.14 H	9	73.90	32.40
4	*2412.00	95.1 AV			1.14 H	9	62.70	32.40
5	2500.00	60.5 PK	74.0	-13.5	1.14 H	359	27.80	32.70
6	2500.00	52.7 AV	54.0	-1.3	1.14 H	359	20.00	32.70
7	4824.00	45.0 PK	74.0	-29.0	1.14 H	216	6.60	38.40
8	4824.00	31.6 AV	54.0	-22.4	1.14 H	216	-6.80	38.40
9	5000.00	52.5 PK	74.0	-21.5	1.29 H	108	13.70	38.80
10	5000.00	48.4 AV	54.0	-5.6	1.29 H	108	9.60	38.80

ANTENNA POLARITY & TEST DISTANCE: VERTICAL AT 3 M

NO.	FREQ. (MHz)	EMISSION LEVEL (dBuV/m)	LIMIT (dBuV/m)	MARGIN (dB)	ANTENNA HEIGHT (m)	TABLE ANGLE (Degree)	RAW VALUE (dBuV)	CORRECTION FACTOR (dB/m)
1	2390.00	71.1 PK	74.0	-2.9	1.00 V	96	38.80	32.30
2	2390.00	51.8 AV	54.0	-2.2	1.00 V	96	19.50	32.30
3	*2412.00	105.2 PK			1.00 V	96	72.80	32.40
4	*2412.00	93.5 AV			1.00 V	96	61.10	32.40
5	2500.00	59.4 PK	74.0	-14.6	1.02 V	176	26.70	32.70
6	2500.00	52.4 AV	54.0	-1.6	1.02 V	176	19.70	32.70
7	4824.00	44.6 PK	74.0	-29.4	1.06 V	220	6.20	38.40
8	4824.00	31.3 AV	54.0	-22.7	1.06 V	220	-7.10	38.40
9	5000.00	51.4 PK	74.0	-22.6	1.05 V	150	12.60	38.80
10	5000.00	47.1 AV	54.0	-6.9	1.05 V	150	8.30	38.80

- REMARKS:**
1. Emission level (dBuV/m) = Raw Value (dBuV) + Correction Factor (dB/m).
 2. Correction Factor (dB/m) = Antenna Factor (dB/m) + Cable Factor (dB).
 3. The other emission levels were very low against the limit.
 4. Margin value = Emission level – Limit value.
 5. “ * “: Fundamental frequency.



A D T

EUT TEST CONDITION		MEASUREMENT DETAIL	
CHANNEL	Channel 6	FREQUENCY RANGE	1 ~ 25GHz
INPUT POWER (SYSTEM)	120Vac, 60 Hz	DETECTOR FUNCTION	Peak (PK) Average (AV)
ENVIRONMENTAL CONDITIONS	25deg. C, 65%RH 1020 hPa	TESTED BY	Brad Wu

ANTENNA POLARITY & TEST DISTANCE: HORIZONTAL AT 3 M								
NO.	FREQ. (MHz)	EMISSION LEVEL (dBuV/m)	LIMIT (dBuV/m)	MARGIN (dB)	ANTENNA HEIGHT (m)	TABLE ANGLE (Degree)	RAW VALUE (dBuV)	CORRECTION FACTOR (dB/m)
1	*2437.00	106.0 PK			1.14 H	2	73.60	32.40
2	*2437.00	94.8 AV			1.14 H	2	62.40	32.40
3	2500.00	60.3 PK	74.0	-13.7	1.15 H	358	27.60	32.70
4	2500.00	52.6 AV	54.0	-1.4	1.15 H	358	19.90	32.70
5	4874.00	46.2 PK	74.0	-27.8	1.09 H	200	7.70	38.50
6	4874.00	32.8 AV	54.0	-21.2	1.09 H	200	-5.70	38.50
7	5000.00	52.3 PK	74.0	-21.7	1.28 H	106	13.50	38.80
8	5000.00	48.2 AV	54.0	-5.8	1.28 H	106	9.40	38.80
ANTENNA POLARITY & TEST DISTANCE: VERTICAL AT 3 M								
NO.	FREQ. (MHz)	EMISSION LEVEL (dBuV/m)	LIMIT (dBuV/m)	MARGIN (dB)	ANTENNA HEIGHT (m)	TABLE ANGLE (Degree)	RAW VALUE (dBuV)	CORRECTION FACTOR (dB/m)
1	*2437.00	105.0 PK			1.01 V	95	72.60	32.40
2	*2437.00	93.4 AV			1.01 V	95	61.00	32.40
3	2500.00	59.5 PK	74.0	-14.5	1.03 V	174	26.80	32.70
4	2500.00	52.2 AV	54.0	-1.8	1.03 V	174	19.50	32.70
5	4874.00	46.0 PK	74.0	-28.0	1.05 V	216	7.50	38.50
6	4874.00	32.5 AV	54.0	-21.5	1.05 V	216	-6.00	38.50
7	5000.00	51.0 PK	74.0	-23.0	1.04 V	146	12.20	38.80
8	5000.00	46.8 AV	54.0	-7.2	1.04 V	146	8.00	38.80

- REMARKS:**
1. Emission level (dBuV/m) = Raw Value (dBuV) + Correction Factor (dB/m).
 2. Correction Factor (dB/m) = Antenna Factor (dB/m) + Cable Factor (dB).
 3. The other emission levels were very low against the limit.
 4. Margin value = Emission level – Limit value.
 5. “ * “: Fundamental frequency.



A D T

EUT TEST CONDITION		MEASUREMENT DETAIL	
CHANNEL	Channel 11	FREQUENCY RANGE	1 ~ 25GHz
INPUT POWER (SYSTEM)	120Vac, 60 Hz	DETECTOR FUNCTION	Peak (PK) Average (AV)
ENVIRONMENTAL CONDITIONS	25deg. C, 65%RH 1020 hPa	TESTED BY	Brad Wu

ANTENNA POLARITY & TEST DISTANCE: HORIZONTAL AT 3 M								
NO.	FREQ. (MHz)	EMISSION LEVEL (dBuV/m)	LIMIT (dBuV/m)	MARGIN (dB)	ANTENNA HEIGHT (m)	TABLE ANGLE (Degree)	RAW VALUE (dBuV)	CORRECTION FACTOR (dB/m)
1	*2462.00	105.6 PK			1.12 H	3	73.10	32.50
2	*2462.00	94.5 AV			1.12 H	3	62.00	32.50
3	2483.50	70.5 PK	74.0	-3.5	1.12 H	3	37.90	32.60
4	2483.50	52.6 AV	54.0	-1.4	1.12 H	3	20.00	32.60
5	2500.00	60.6 PK	74.0	-13.4	1.16 H	359	27.90	32.70
6	2500.00	52.9 AV	54.0	-1.1	1.16 H	359	20.20	32.70
7	4924.00	46.4 PK	74.0	-27.6	1.06 H	198	7.80	38.60
8	4924.00	33.0 AV	54.0	-21.0	1.06 H	198	-5.60	38.60
9	5000.00	52.6 PK	74.0	-21.4	1.26 H	104	13.80	38.80
10	5000.00	48.5 AV	54.0	-5.5	1.26 H	104	9.70	38.80
ANTENNA POLARITY & TEST DISTANCE: VERTICAL AT 3 M								
NO.	FREQ. (MHz)	EMISSION LEVEL (dBuV/m)	LIMIT (dBuV/m)	MARGIN (dB)	ANTENNA HEIGHT (m)	TABLE ANGLE (Degree)	RAW VALUE (dBuV)	CORRECTION FACTOR (dB/m)
1	*2462.00	104.8 PK			1.02 V	96	72.30	32.50
2	*2462.00	93.2 AV			1.02 V	96	60.70	32.50
3	2483.50	69.4 PK	74.0	-4.6	1.02 V	96	36.80	32.60
4	2483.50	51.3 AV	54.0	-2.7	1.02 V	96	18.70	32.60
5	2500.00	59.4 PK	74.0	-14.6	1.02 V	176	26.70	32.70
6	2500.00	52.0 AV	54.0	-2.0	1.02 V	176	19.30	32.70
7	4924.00	45.8 PK	74.0	-28.2	1.02 V	209	7.20	38.60
8	4924.00	32.4 AV	54.0	-21.6	1.02 V	209	-6.20	38.60
9	5000.00	51.2 PK	74.0	-22.8	1.05 V	148	12.40	38.80
10	5000.00	47.0 AV	54.0	-7.0	1.05 V	148	8.20	38.80

- REMARKS:**
1. Emission level (dBuV/m) = Raw Value (dBuV) + Correction Factor (dB/m).
 2. Correction Factor (dB/m) = Antenna Factor (dB/m) + Cable Factor (dB).
 3. The other emission levels were very low against the limit.
 4. Margin value = Emission level – Limit value.
 5. “ * ”: Fundamental frequency.



A D T

802.11g (Antenna B)

EUT TEST CONDITION		MEASUREMENT DETAIL	
CHANNEL	Channel 1	FREQUENCY RANGE	1 ~ 25GHz
INPUT POWER (SYSTEM)	120Vac, 60 Hz	DETECTOR FUNCTION	Peak (PK) Average (AV)
ENVIRONMENTAL CONDITIONS	25deg. C, 65%RH 1020 hPa	TESTED BY	Brad Wu

ANTENNA POLARITY & TEST DISTANCE: HORIZONTAL AT 3 M

NO.	FREQ. (MHz)	EMISSION LEVEL (dBuV/m)	LIMIT (dBuV/m)	MARGIN (dB)	ANTENNA HEIGHT (m)	TABLE ANGLE (Degree)	RAW VALUE (dBuV)	CORRECTION FACTOR (dB/m)
1	2390.00	69.4 PK	74.0	-4.6	1.12 H	281	37.10	32.30
2	2390.00	53.0 AV	54.0	-1.0	1.12 H	281	20.70	32.30
3	*2412.00	108.9 PK			1.11 H	284	76.50	32.40
4	*2412.00	97.8 AV			1.11 H	284	65.40	32.40
5	2500.00	59.2 PK	74.0	-14.8	1.08 H	93	26.50	32.70
6	2500.00	48.4 AV	54.0	-5.6	1.08 H	93	15.70	32.70
7	4824.00	46.1 PK	74.0	-27.9	1.09 H	210	7.70	38.40
8	4824.00	32.8 AV	54.0	-21.2	1.09 H	210	-5.60	38.40
9	5000.00	53.3 PK	74.0	-20.7	1.25 H	105	14.50	38.80
10	5000.00	49.5 AV	54.0	-4.5	1.25 H	105	10.70	38.80

ANTENNA POLARITY & TEST DISTANCE: VERTICAL AT 3 M

NO.	FREQ. (MHz)	EMISSION LEVEL (dBuV/m)	LIMIT (dBuV/m)	MARGIN (dB)	ANTENNA HEIGHT (m)	TABLE ANGLE (Degree)	RAW VALUE (dBuV)	CORRECTION FACTOR (dB/m)
1	2390.00	60.7 PK	74.0	-13.3	1.09 V	2	28.40	32.30
2	2390.00	48.9 AV	54.0	-5.1	1.09 V	2	16.60	32.30
3	*2412.00	102.8 PK			1.08 V	2	70.40	32.40
4	*2412.00	91.7 AV			1.08 V	2	59.30	32.40
5	2500.00	58.5 PK	74.0	-15.5	1.09 V	2	25.80	32.70
6	2500.00	48.4 AV	54.0	-5.6	1.09 V	2	15.70	32.70
7	4824.00	45.8 PK	74.0	-28.2	1.04 V	231	7.40	38.40
8	4824.00	32.5 AV	54.0	-21.5	1.04 V	231	-5.90	38.40
9	5000.00	52.1 PK	74.0	-21.9	1.08 V	177	13.30	38.80
10	5000.00	46.6 AV	54.0	-7.4	1.08 V	177	7.80	38.80

- REMARKS:**
1. Emission level (dBuV/m) = Raw Value (dBuV) + Correction Factor (dB/m).
 2. Correction Factor (dB/m) = Antenna Factor (dB/m) + Cable Factor (dB).
 3. The other emission levels were very low against the limit.
 4. Margin value = Emission level – Limit value.
 5. “ * “: Fundamental frequency.



A D T

EUT TEST CONDITION		MEASUREMENT DETAIL	
CHANNEL	Channel 6	FREQUENCY RANGE	1 ~ 25GHz
INPUT POWER (SYSTEM)	120Vac, 60 Hz	DETECTOR FUNCTION	Peak (PK) Average (AV)
ENVIRONMENTAL CONDITIONS	25deg. C, 65%RH 1020 hPa	TESTED BY	Brad Wu

ANTENNA POLARITY & TEST DISTANCE: HORIZONTAL AT 3 M								
NO.	FREQ. (MHz)	EMISSION LEVEL (dBuV/m)	LIMIT (dBuV/m)	MARGIN (dB)	ANTENNA HEIGHT (m)	TABLE ANGLE (Degree)	RAW VALUE (dBuV)	CORRECTION FACTOR (dB/m)
1	*2437.00	109.1 PK			1.09 H	284	76.70	32.40
2	*2437.00	98.0 AV			1.09 H	284	65.60	32.40
3	4874.00	46.5 PK	74.0	-27.5	1.06 H	208	8.00	38.50
4	4874.00	33.2 AV	54.0	-20.8	1.06 H	208	-5.30	38.50
5	5000.00	52.6 PK	74.0	-21.4	1.09 H	104	13.80	38.80
6	5000.00	48.3 AV	54.0	-5.7	1.09 H	104	9.50	38.80
ANTENNA POLARITY & TEST DISTANCE: VERTICAL AT 3 M								
NO.	FREQ. (MHz)	EMISSION LEVEL (dBuV/m)	LIMIT (dBuV/m)	MARGIN (dB)	ANTENNA HEIGHT (m)	TABLE ANGLE (Degree)	RAW VALUE (dBuV)	CORRECTION FACTOR (dB/m)
1	*2437.00	103.0 PK			1.09 V	4	70.60	32.40
2	*2437.00	91.9 AV			1.09 V	4	59.50	32.40
3	4874.00	46.1 PK	74.0	-27.9	1.06 V	209	7.60	38.50
4	4874.00	32.8 AV	54.0	-21.2	1.06 V	209	-5.70	38.50
5	5000.00	52.4 PK	74.0	-21.6	1.10 V	168	13.60	38.80
6	5000.00	46.9 AV	54.0	-7.1	1.10 V	168	8.10	38.80

- REMARKS:**
1. Emission level (dBuV/m) = Raw Value (dBuV) + Correction Factor (dB/m).
 2. Correction Factor (dB/m) = Antenna Factor (dB/m) + Cable Factor (dB).
 3. The other emission levels were very low against the limit.
 4. Margin value = Emission level – Limit value.
 5. “ * “: Fundamental frequency.



A D T

EUT TEST CONDITION		MEASUREMENT DETAIL	
CHANNEL	Channel 11	FREQUENCY RANGE	1 ~ 25GHz
INPUT POWER (SYSTEM)	120Vac, 60 Hz	DETECTOR FUNCTION	Peak (PK) Average (AV)
ENVIRONMENTAL CONDITIONS	25deg. C, 65%RH 1020 hPa	TESTED BY	Brad Wu

ANTENNA POLARITY & TEST DISTANCE: HORIZONTAL AT 3 M								
NO.	FREQ. (MHz)	EMISSION LEVEL (dBuV/m)	LIMIT (dBuV/m)	MARGIN (dB)	ANTENNA HEIGHT (m)	TABLE ANGLE (Degree)	RAW VALUE (dBuV)	CORRECTION FACTOR (dB/m)
1	*2462.00	108.3 PK			1.08 H	286	75.80	32.50
2	*2462.00	97.1 AV			1.08 H	286	64.60	32.50
3	2483.50	68.4 PK	74.0	-5.6	1.08 H	286	35.80	32.60
4	2483.50	52.8 AV	54.0	-1.2	1.08 H	286	20.20	32.60
5	4924.00	46.8 PK	74.0	-27.2	1.05 H	219	8.20	38.60
6	4924.00	33.5 AV	54.0	-20.5	1.05 H	219	-5.10	38.60
7	5000.00	52.4 PK	74.0	-21.6	1.06 H	100	13.60	38.80
8	5000.00	48.1 AV	54.0	-5.9	1.06 H	100	9.30	38.80
ANTENNA POLARITY & TEST DISTANCE: VERTICAL AT 3 M								
NO.	FREQ. (MHz)	EMISSION LEVEL (dBuV/m)	LIMIT (dBuV/m)	MARGIN (dB)	ANTENNA HEIGHT (m)	TABLE ANGLE (Degree)	RAW VALUE (dBuV)	CORRECTION FACTOR (dB/m)
1	*2462.00	102.2 PK			1.10 V	5	69.70	32.50
2	*2462.00	91.1 AV			1.10 V	5	58.60	32.50
3	2483.50	61.1 PK	74.0	-12.9	1.10 V	5	28.50	32.60
4	2483.50	49.2 AV	54.0	-4.8	1.10 V	5	16.60	32.60
5	4924.00	52.1 PK	74.0	-21.9	1.10 V	105	13.50	38.60
6	4924.00	46.6 AV	54.0	-7.4	1.10 V	105	8.00	38.60
7	5000.00	52.0 PK	74.0	-22.0	1.09 V	159	13.20	38.80
8	5000.00	46.3 AV	54.0	-7.7	1.09 V	159	7.50	38.80

- REMARKS:**
1. Emission level (dBuV/m) = Raw Value (dBuV) + Correction Factor (dB/m).
 2. Correction Factor (dB/m) = Antenna Factor (dB/m) + Cable Factor (dB).
 3. The other emission levels were very low against the limit.
 4. Margin value = Emission level – Limit value.
 5. “ * “: Fundamental frequency.



A D T

802.11n (20MHz)

EUT TEST CONDITION		MEASUREMENT DETAIL	
CHANNEL	Channel 1	FREQUENCY RANGE	1 ~ 25GHz
INPUT POWER (SYSTEM)	120Vac, 60 Hz	DETECTOR FUNCTION	Peak (PK) Average (AV)
ENVIRONMENTAL CONDITIONS	25deg. C, 65%RH 1016 hPa	TESTED BY	Sun Lin

ANTENNA POLARITY & TEST DISTANCE: HORIZONTAL AT 3 M								
NO.	FREQ. (MHz)	EMISSION LEVEL (dBuV/m)	LIMIT (dBuV/m)	MARGIN (dB)	ANTENNA HEIGHT (m)	TABLE ANGLE (Degree)	RAW VALUE (dBuV)	CORRECTION FACTOR (dB/m)
1	2390.00	69.8 PK	74.0	-4.2	1.44 H	333	37.50	32.30
2	2390.00	52.7 AV	54.0	-1.3	1.44 H	333	20.40	32.30
3	*2412.00	107.6 PK			1.44 H	328	75.20	32.40
4	*2412.00	94.7 AV			1.44 H	328	62.30	32.40
5	2500.00	56.7 PK	74.0	-17.3	1.47 H	99	24.00	32.70
6	2500.00	46.4 AV	54.0	-7.6	1.47 H	99	13.70	32.70
7	4824.00	44.8 PK	74.0	-29.2	1.12 H	118	6.40	38.40
8	4824.00	33.0 AV	54.0	-21.0	1.12 H	118	-5.40	38.40
9	5000.00	51.7 PK	74.0	-22.3	1.00 H	177	12.90	38.80
10	5000.00	47.2 AV	54.0	-6.8	1.00 H	177	8.40	38.80
ANTENNA POLARITY & TEST DISTANCE: VERTICAL AT 3 M								
NO.	FREQ. (MHz)	EMISSION LEVEL (dBuV/m)	LIMIT (dBuV/m)	MARGIN (dB)	ANTENNA HEIGHT (m)	TABLE ANGLE (Degree)	RAW VALUE (dBuV)	CORRECTION FACTOR (dB/m)
1	2390.00	62.9 PK	74.0	-11.1	1.43 V	8	30.60	32.30
2	2390.00	49.0 AV	54.0	-5.0	1.43 V	8	16.70	32.30
3	*2412.00	104.2 PK			1.20 V	6	71.80	32.40
4	*2412.00	90.8 AV			1.20 V	6	58.40	32.40
5	2500.00	58.8 PK	74.0	-15.2	1.30 V	100	26.10	32.70
6	2500.00	52.6 AV	54.0	-1.4	1.30 V	100	19.90	32.70
7	4824.00	44.5 PK	74.0	-29.5	1.18 V	213	6.10	38.40
8	4824.00	33.7 AV	54.0	-20.3	1.18 V	213	-4.70	38.40
9	5000.00	51.0 PK	74.0	-23.0	1.06 V	183	12.20	38.80
10	5000.00	46.0 AV	54.0	-8.0	1.06 V	183	7.20	38.80

- REMARKS:**
1. Emission level (dBuV/m) = Raw Value (dBuV) + Correction Factor (dB/m).
 2. Correction Factor (dB/m) = Antenna Factor (dB/m) + Cable Factor (dB).
 3. The other emission levels were very low against the limit.
 4. Margin value = Emission level – Limit value.
 5. “ * ”: Fundamental frequency.



A D T

EUT TEST CONDITION		MEASUREMENT DETAIL	
CHANNEL	Channel 6	FREQUENCY RANGE	1 ~ 25GHz
INPUT POWER (SYSTEM)	120Vac, 60 Hz	DETECTOR FUNCTION	Peak (PK) Average (AV)
ENVIRONMENTAL CONDITIONS	25deg. C, 65%RH 1016 hPa	TESTED BY	Sun Lin

ANTENNA POLARITY & TEST DISTANCE: HORIZONTAL AT 3 M								
NO.	FREQ. (MHz)	EMISSION LEVEL (dBuV/m)	LIMIT (dBuV/m)	MARGIN (dB)	ANTENNA HEIGHT (m)	TABLE ANGLE (Degree)	RAW VALUE (dBuV)	CORRECTION FACTOR (dB/m)
1	*2437.00	107.2 PK			1.28 H	308	74.80	32.40
2	*2437.00	94.0 AV			1.28 H	308	61.60	32.40
3	2500.00	56.3 PK	74.0	-17.7	1.48 H	102	23.60	32.70
4	2500.00	46.0 AV	54.0	-8.0	1.48 H	102	13.30	32.70
5	4874.00	44.7 PK	74.0	-29.3	1.18 H	107	6.20	38.50
6	4874.00	33.2 AV	54.0	-20.8	1.18 H	107	-5.30	38.50
7	5000.00	51.5 PK	74.0	-22.5	1.01 H	185	12.70	38.80
8	5000.00	47.6 AV	54.0	-6.4	1.01 H	185	8.80	38.80
ANTENNA POLARITY & TEST DISTANCE: VERTICAL AT 3 M								
NO.	FREQ. (MHz)	EMISSION LEVEL (dBuV/m)	LIMIT (dBuV/m)	MARGIN (dB)	ANTENNA HEIGHT (m)	TABLE ANGLE (Degree)	RAW VALUE (dBuV)	CORRECTION FACTOR (dB/m)
1	*2437.00	103.8 PK			1.18 V	6	71.40	32.40
2	*2437.00	90.3 AV			1.18 V	6	57.90	32.40
3	2500.00	59.3 PK	74.0	-14.7	1.31 V	99	26.60	32.70
4	2500.00	52.7 AV	54.0	-1.3	1.31 V	99	20.00	32.70
5	4874.00	44.8 PK	74.0	-29.2	1.07 V	208	6.30	38.50
6	4874.00	34.0 AV	54.0	-20.0	1.07 V	208	-4.50	38.50
7	5000.00	50.8 PK	74.0	-23.2	1.07 V	173	12.00	38.80
8	5000.00	45.9 AV	54.0	-8.1	1.07 V	173	7.10	38.80

- REMARKS:**
1. Emission level (dBuV/m) = Raw Value (dBuV) + Correction Factor (dB/m).
 2. Correction Factor (dB/m) = Antenna Factor (dB/m) + Cable Factor (dB).
 3. The other emission levels were very low against the limit.
 4. Margin value = Emission level – Limit value.
 5. “ * “: Fundamental frequency.



A D T

EUT TEST CONDITION		MEASUREMENT DETAIL	
CHANNEL	Channel 11	FREQUENCY RANGE	1 ~ 25GHz
INPUT POWER (SYSTEM)	120Vac, 60 Hz	DETECTOR FUNCTION	Peak (PK) Average (AV)
ENVIRONMENTAL CONDITIONS	25deg. C, 65%RH 1016 hPa	TESTED BY	Sun Lin

ANTENNA POLARITY & TEST DISTANCE: HORIZONTAL AT 3 M								
NO.	FREQ. (MHz)	EMISSION LEVEL (dBuV/m)	LIMIT (dBuV/m)	MARGIN (dB)	ANTENNA HEIGHT (m)	TABLE ANGLE (Degree)	RAW VALUE (dBuV)	CORRECTION FACTOR (dB/m)
1	*2462.00	106.1 PK			1.42 H	336	75.40	30.70
2	*2462.00	93.1 AV			1.42 H	336	62.40	30.70
3	2483.50	69.3 PK	74.0	-4.7	1.40 H	338	38.50	30.80
4	2483.50	52.4 AV	54.0	-1.6	1.40 H	338	21.60	30.80
5	2500.00	56.8 PK	74.0	-17.2	1.43 H	102	25.90	30.90
6	2500.00	46.7 AV	54.0	-7.3	1.43 H	102	15.80	30.90
7	4924.00	45.0 PK	74.0	-29.0	1.17 H	120	8.70	36.30
8	4924.00	33.5 AV	54.0	-20.5	1.17 H	120	-2.80	36.30
9	5000.00	52.0 PK	74.0	-22.0	1.05 H	187	15.50	36.50
10	5000.00	47.4 AV	54.0	-6.6	1.05 H	187	10.90	36.50
ANTENNA POLARITY & TEST DISTANCE: VERTICAL AT 3 M								
NO.	FREQ. (MHz)	EMISSION LEVEL (dBuV/m)	LIMIT (dBuV/m)	MARGIN (dB)	ANTENNA HEIGHT (m)	TABLE ANGLE (Degree)	RAW VALUE (dBuV)	CORRECTION FACTOR (dB/m)
1	*2462.00	102.7 PK			1.79 V	31	70.20	32.50
2	*2462.00	89.4 AV			1.79 V	31	56.90	32.50
3	2483.50	62.7 PK	74.0	-11.3	1.79 V	38	30.10	32.60
4	2483.50	49.0 AV	54.0	-5.0	1.79 V	38	16.40	32.60
5	2500.00	58.9 PK	74.0	-15.1	1.27 V	98	26.20	32.70
6	2500.00	52.7 AV	54.0	-1.3	1.27 V	98	20.00	32.70
7	4924.00	44.3 PK	74.0	-29.7	1.25 V	232	5.70	38.60
8	4924.00	33.9 AV	54.0	-20.1	1.25 V	232	-4.70	38.60
9	5000.00	50.8 PK	74.0	-23.2	1.09 V	175	12.00	38.80
10	5000.00	45.8 AV	54.0	-8.2	1.09 V	175	7.00	38.80

- REMARKS:**
1. Emission level (dBuV/m) = Raw Value (dBuV) + Correction Factor (dB/m).
 2. Correction Factor (dB/m) = Antenna Factor (dB/m) + Cable Factor (dB).
 3. The other emission levels were very low against the limit.
 4. Margin value = Emission level – Limit value.
 5. “ * ”: Fundamental frequency.



A D T

802.11n (40MHz)

EUT TEST CONDITION		MEASUREMENT DETAIL	
CHANNEL	Channel 1	FREQUENCY RANGE	1 ~ 25GHz
INPUT POWER (SYSTEM)	120Vac, 60 Hz	DETECTOR FUNCTION	Peak (PK) Average (AV)
ENVIRONMENTAL CONDITIONS	25deg. C, 65%RH 1020 hPa	TESTED BY	Sun Lin

ANTENNA POLARITY & TEST DISTANCE: HORIZONTAL AT 3 M

NO.	FREQ. (MHz)	EMISSION LEVEL (dBuV/m)	LIMIT (dBuV/m)	MARGIN (dB)	ANTENNA HEIGHT (m)	TABLE ANGLE (Degree)	RAW VALUE (dBuV)	CORRECTION FACTOR (dB/m)
1	2390.00	68.4 PK	74.0	-5.6	1.44 H	330	36.10	32.30
2	2390.00	52.6 AV	54.0	-1.4	1.44 H	330	20.30	32.30
3	*2422.00	103.8 PK			1.44 H	328	71.40	32.40
4	*2422.00	87.9 AV			1.44 H	328	55.50	32.40
5	2500.00	56.9 PK	74.0	-17.1	1.37 H	102	24.20	32.70
6	2500.00	46.7 AV	54.0	-7.3	1.37 H	102	14.00	32.70
7	4844.00	44.7 PK	74.0	-29.3	1.08 H	128	6.30	38.40
8	4844.00	33.2 AV	54.0	-20.8	1.08 H	128	-5.20	38.40
9	5000.00	51.9 PK	74.0	-22.1	1.01 H	168	13.10	38.80
10	5000.00	47.6 AV	54.0	-6.4	1.01 H	168	8.80	38.80

ANTENNA POLARITY & TEST DISTANCE: VERTICAL AT 3 M

NO.	FREQ. (MHz)	EMISSION LEVEL (dBuV/m)	LIMIT (dBuV/m)	MARGIN (dB)	ANTENNA HEIGHT (m)	TABLE ANGLE (Degree)	RAW VALUE (dBuV)	CORRECTION FACTOR (dB/m)
1	2390.00	64.8 PK	74.0	-9.2	1.00 V	18	32.50	32.30
2	2390.00	49.3 AV	54.0	-4.7	1.00 V	18	17.00	32.30
3	*2422.00	102.1 PK			1.00 V	12	69.70	32.40
4	*2422.00	85.8 AV			1.00 V	12	53.40	32.40
5	2500.00	58.9 PK	74.0	-15.1	1.32 V	107	26.20	32.70
6	2500.00	52.8 AV	54.0	-1.2	1.32 V	107	20.10	32.70
7	4844.00	44.8 PK	74.0	-29.2	1.12 V	237	6.40	38.40
8	4844.00	33.6 AV	54.0	-20.4	1.12 V	237	-4.80	38.40
9	5000.00	50.7 PK	74.0	-23.3	1.08 V	165	11.90	38.80
10	5000.00	45.9 AV	54.0	-8.1	1.08 V	165	7.10	38.80

- REMARKS:**
1. Emission level (dBuV/m) = Raw Value (dBuV) + Correction Factor (dB/m).
 2. Correction Factor (dB/m) = Antenna Factor (dB/m) + Cable Factor (dB).
 3. The other emission levels were very low against the limit.
 4. Margin value = Emission level – Limit value.
 5. “ * “: Fundamental frequency.



A D T

EUT TEST CONDITION		MEASUREMENT DETAIL	
CHANNEL	Channel 4	FREQUENCY RANGE	1 ~ 25GHz
INPUT POWER (SYSTEM)	120Vac, 60 Hz	DETECTOR FUNCTION	Peak (PK) Average (AV)
ENVIRONMENTAL CONDITIONS	25deg. C, 65%RH 1020 hPa	TESTED BY	Sun Lin

ANTENNA POLARITY & TEST DISTANCE: HORIZONTAL AT 3 M								
NO.	FREQ. (MHz)	EMISSION LEVEL (dBuV/m)	LIMIT (dBuV/m)	MARGIN (dB)	ANTENNA HEIGHT (m)	TABLE ANGLE (Degree)	RAW VALUE (dBuV)	CORRECTION FACTOR (dB/m)
1	*2437.00	103.3 PK			1.34 H	322	70.90	32.40
2	*2437.00	87.3 AV			1.34 H	322	54.90	32.40
3	2500.00	56.7 PK	74.0	-17.3	1.26 H	105	24.00	32.70
4	2500.00	46.2 AV	54.0	-7.8	1.26 H	105	13.50	32.70
5	4874.00	44.8 PK	74.0	-29.2	1.09 H	133	6.30	38.50
6	4874.00	33.5 AV	54.0	-20.5	1.09 H	133	-5.00	38.50
7	5000.00	51.7 PK	74.0	-22.3	1.00 H	158	12.90	38.80
8	5000.00	47.9 AV	54.0	-6.1	1.00 H	158	9.10	38.80
ANTENNA POLARITY & TEST DISTANCE: VERTICAL AT 3 M								
NO.	FREQ. (MHz)	EMISSION LEVEL (dBuV/m)	LIMIT (dBuV/m)	MARGIN (dB)	ANTENNA HEIGHT (m)	TABLE ANGLE (Degree)	RAW VALUE (dBuV)	CORRECTION FACTOR (dB/m)
1	*2437.00	101.7 PK			1.02 V	15	69.30	32.40
2	*2437.00	85.2 AV			1.02 V	15	52.80	32.40
3	2500.00	58.5 PK	74.0	-15.5	1.22 V	100	25.80	32.70
4	2500.00	52.7 AV	54.0	-1.3	1.22 V	100	20.00	32.70
5	4874.00	44.7 PK	74.0	-29.3	1.27 V	240	6.20	38.50
6	4874.00	33.2 AV	54.0	-20.8	1.27 V	240	-5.30	38.50
7	5000.00	50.8 PK	74.0	-23.2	1.12 V	177	12.00	38.80
8	5000.00	45.7 AV	54.0	-8.3	1.12 V	177	6.90	38.80

- REMARKS:**
1. Emission level (dBuV/m) = Raw Value (dBuV) + Correction Factor (dB/m).
 2. Correction Factor (dB/m) = Antenna Factor (dB/m) + Cable Factor (dB).
 3. The other emission levels were very low against the limit.
 4. Margin value = Emission level – Limit value.
 5. “ * “: Fundamental frequency.



A D T

EUT TEST CONDITION		MEASUREMENT DETAIL	
CHANNEL	Channel 7	FREQUENCY RANGE	1 ~ 25GHz
INPUT POWER (SYSTEM)	120Vac, 60 Hz	DETECTOR FUNCTION	Peak (PK) Average (AV)
ENVIRONMENTAL CONDITIONS	25deg. C, 65%RH 1020 hPa	TESTED BY	Sun Lin

ANTENNA POLARITY & TEST DISTANCE: HORIZONTAL AT 3 M								
NO.	FREQ. (MHz)	EMISSION LEVEL (dBuV/m)	LIMIT (dBuV/m)	MARGIN (dB)	ANTENNA HEIGHT (m)	TABLE ANGLE (Degree)	RAW VALUE (dBuV)	CORRECTION FACTOR (dB/m)
1	*2452.00	103.0 PK			1.43 H	338	70.50	32.50
2	*2452.00	87.0 AV			1.43 H	338	54.50	32.50
3	2483.50	67.2 PK	74.0	-6.8	1.38 H	339	34.60	32.60
4	2483.50	52.5 AV	54.0	-1.5	1.38 H	339	19.90	32.60
5	2500.00	56.7 PK	74.0	-17.3	1.28 H	100	24.00	32.70
6	2500.00	46.8 AV	54.0	-7.2	1.28 H	100	14.10	32.70
7	4904.00	44.8 PK	74.0	-29.2	1.12 H	135	6.30	38.50
8	4904.00	33.6 AV	54.0	-20.4	1.12 H	135	-4.90	38.50
9	5000.00	51.6 PK	74.0	-22.4	1.00 H	177	12.80	38.80
10	5000.00	47.5 AV	54.0	-6.5	1.00 H	177	8.70	38.80
ANTENNA POLARITY & TEST DISTANCE: VERTICAL AT 3 M								
NO.	FREQ. (MHz)	EMISSION LEVEL (dBuV/m)	LIMIT (dBuV/m)	MARGIN (dB)	ANTENNA HEIGHT (m)	TABLE ANGLE (Degree)	RAW VALUE (dBuV)	CORRECTION FACTOR (dB/m)
1	*2452.00	101.8 PK			1.02 V	15	69.30	32.50
2	*2452.00	85.3 AV			1.02 V	15	52.80	32.50
3	2483.50	65.2 PK	74.0	-8.8	1.00 V	23	32.60	32.60
4	2483.50	49.3 AV	54.0	-4.7	1.00 V	23	16.70	32.60
5	2500.00	58.8 PK	74.0	-15.2	1.26 V	102	26.10	32.70
6	2500.00	52.7 AV	54.0	-1.3	1.26 V	102	20.00	32.70
7	4904.00	45.0 PK	74.0	-29.0	1.18 V	253	6.50	38.50
8	4904.00	33.7 AV	54.0	-20.3	1.18 V	253	-4.80	38.50
9	5000.00	50.8 PK	74.0	-23.2	1.02 V	189	12.00	38.80
10	5000.00	46.2 AV	54.0	-7.8	1.02 V	189	7.40	38.80

- REMARKS:**
1. Emission level (dBuV/m) = Raw Value (dBuV) + Correction Factor (dB/m).
 2. Correction Factor (dB/m) = Antenna Factor (dB/m) + Cable Factor (dB).
 3. The other emission levels were very low against the limit.
 4. Margin value = Emission level – Limit value.
 5. “ * “: Fundamental frequency.



A D T

BELOW 1GHz WORST-CASE DATA : 802.11n (20MHz)

EUT TEST CONDITION		MEASUREMENT DETAIL	
CHANNEL	Channel 6	FREQUENCY RANGE	Below 1000MHz
INPUT POWER (SYSTEM)	120Vac, 60 Hz	DETECTOR FUNCTION	Quasi-Peak
ENVIRONMENTAL CONDITIONS	25deg. C, 65%RH 1008 hPa	TESTED BY	Brad Wu

ANTENNA POLARITY & TEST DISTANCE: HORIZONTAL AT 3 M								
NO.	FREQ. (MHz)	EMISSION LEVEL (dBuV/m)	LIMIT (dBuV/m)	MARGIN (dB)	ANTENNA HEIGHT (m)	TABLE ANGLE (Degree)	RAW VALUE (dBuV)	CORRECTION FACTOR (dB/m)
1	96.01	27.9 QP	43.5	-15.6	2.00 H	103	18.60	9.30
2	393.48	38.7 QP	46.0	-7.3	1.00 H	328	22.70	16.00
3	480.97	39.2 QP	46.0	-6.8	1.50 H	58	20.50	18.70
4	667.63	34.1 QP	46.0	-11.9	1.00 H	49	11.60	22.50
5	751.23	37.3 QP	46.0	-8.7	2.00 H	145	13.30	24.00
6	877.61	38.3 QP	46.0	-7.7	1.50 H	247	12.40	25.90
ANTENNA POLARITY & TEST DISTANCE: VERTICAL AT 3 M								
NO.	FREQ. (MHz)	EMISSION LEVEL (dBuV/m)	LIMIT (dBuV/m)	MARGIN (dB)	ANTENNA HEIGHT (m)	TABLE ANGLE (Degree)	RAW VALUE (dBuV)	CORRECTION FACTOR (dB/m)
1	99.89	32.3 QP	43.5	-11.2	1.25 V	70	22.90	9.40
2	393.48	38.6 QP	46.0	-7.4	1.50 V	271	22.60	16.00
3	480.97	40.1 QP	46.0	-5.9	1.25 V	283	21.40	18.70
4	667.63	32.0 QP	46.0	-14.0	2.00 V	43	9.50	22.50
5	751.23	35.6 QP	46.0	-10.4	2.00 V	190	11.60	24.00
6	877.61	38.5 QP	46.0	-7.5	1.25 V	25	12.60	25.90

- REMARKS:**
1. Emission level (dBuV/m) = Raw Value (dBuV) + Correction Factor (dB/m).
 2. Correction Factor (dB/m) = Antenna Factor (dB/m) + Cable Factor (dB).
 3. The other emission levels were very low against the limit.
 4. Margin value = Emission level – Limit value.



4.2 CONDUCTED EMISSION MEASUREMENT

4.2.1 LIMITS OF CONDUCTED EMISSION MEASUREMENT

FREQUENCY OF EMISSION (MHz)	CONDUCTED LIMIT (dBµV)	
	Quasi-peak	Average
0.15 ~ 0.5	66 to 56	56 to 46
0.5 ~ 5	56	46
5 ~ 30	60	50

- NOTE:** 1. The lower limit shall apply at the transition frequencies.
 2. The limit decreases in line with the logarithm of the frequency in the range of 0.15 to 0.50MHz.
 3. All emanations from a class A/B digital device or system, including any network of conductors and apparatus connected thereto, shall not exceed the level of field strengths specified above.

4.2.2 TEST INSTRUMENTS

DESCRIPTION & MANUFACTURER	MODEL NO.	SERIAL NO.	DATE OF CALIBRATION	DUE DATE OF CALIBRATION
Test Receiver ROHDE & SCHWARZ	ESCS30	100291	Dec. 16, 2009	Dec. 15, 2010
RF signal cable Woken	5D-FB	Cable-HYC01-01	Nov. 12, 2009	Nov. 11, 2010
LISN ROHDE & SCHWARZ	ESH3-Z5	100312	Jun. 28, 2010	Jun. 27, 2011
LISN ROHDE & SCHWARZ	ESH3-Z5	835239/001	Feb. 10, 2010	Feb. 09, 2011
Software ADT	ADT_Cond_ V7.3.7	NA	NA	NA

- NOTE:** 1. The calibration interval of the above test instruments is 12 months and the calibrations are traceable to NML/ROC and NIST/USA.
 2. The test was performed in HwaYa Shielded Room 1.
 3. The VCCI Site Registration No. is C-2040.



A D T

4.2.3 TEST PROCEDURES

- a. The EUT was placed 0.4 meters from the conducting wall of the shielded room with EUT being connected to the power mains through a line impedance stabilization network (LISN). Other support units were connected to the power mains through another LISN. The two LISNs provide 50 ohm/ 50uH of coupling impedance for the measuring instrument.
- b. Both lines of the power mains connected to the EUT were checked for maximum conducted interference.
- c. The frequency range from 150kHz to 30MHz was searched. Emission levels under (Limit - 20dB) was not recorded.

NOTE: All modes of operation were investigated and the worst-case emissions are reported.

4.2.4 DEVIATION FROM TEST STANDARD

No deviation

4.2.5 TEST SETUP

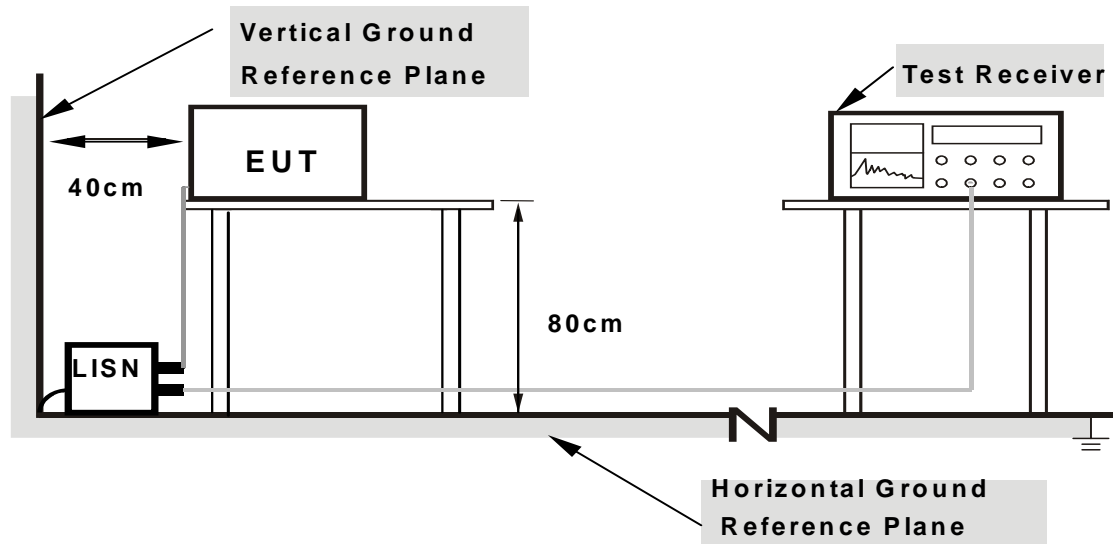

- Note:**
1. Support units were connected to second LISN.
 2. Both of LISNs (AMN) are 80 cm from EUT and at least 80 from other units and other metal planes

For the actual test configuration, please refer to the attached file (Test Setup Photo).

4.2.6 EUT OPERATING CONDITIONS

Same as 4.1.6.

4.2.7 TEST RESULTS

CONDUCTED WORST-CASE DATA : 802.11n (20MHz)

PHASE	Line 1	6dB BANDWIDTH	9kHz
-------	--------	---------------	------

No	Freq.	Corr.	Reading Value		Emission Level		Limit		Margin	
	[MHz]	Factor (dB)	[dB (uV)]		[dB (uV)]		[dB (uV)]		(dB)	
			Q.P.	AV.	Q.P.	AV.	Q.P.	AV.	Q.P.	AV.
1	0.150	0.12	55.84	-	55.96	-	66.00	56.00	-10.04	-
2	0.205	0.11	50.31	-	50.42	-	63.42	53.42	-13.00	-
3	0.271	0.12	41.48	-	41.60	-	61.08	51.08	-19.49	-
4	0.611	0.15	31.83	-	31.98	-	56.00	46.00	-24.02	-
5	3.215	0.31	32.06	-	32.37	-	56.00	46.00	-23.63	-
6	6.531	0.47	39.65	-	40.12	-	60.00	50.00	-19.88	-

- REMARKS:**
1. Q.P. and AV. are abbreviations of quasi-peak and average individually.
 2. "-": The Quasi-peak reading value also meets average limit and measurement with the average detector is unnecessary.
 3. The emission levels of other frequencies were very low against the limit.
 4. Margin value = Emission level - Limit value
 5. Correction factor = Insertion loss + Cable loss
 6. Emission Level = Correction Factor + Reading Value.

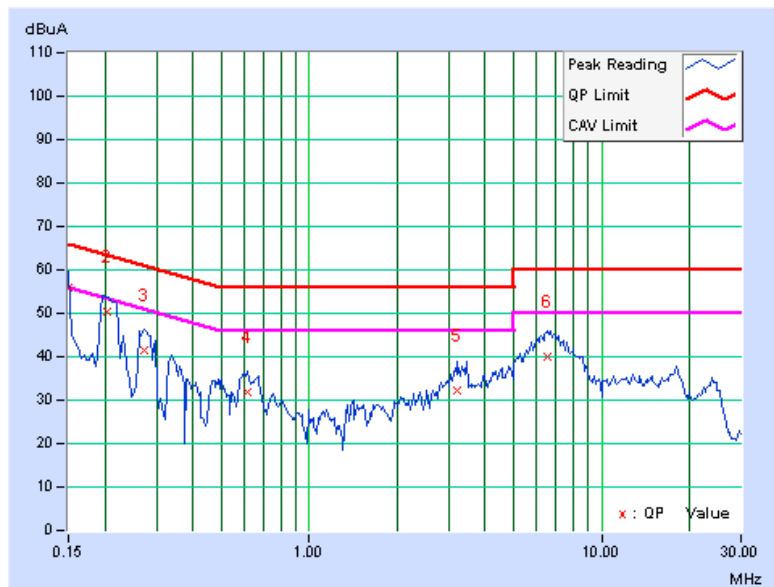

PHASE	Line 2	6dB BANDWIDTH	9kHz
-------	--------	---------------	------

No	Freq. [MHz]	Corr. Factor (dB)	Reading Value		Emission Level		Limit		Margin	
			[dB (uV)]		[dB (uV)]		[dB (uV)]		(dB)	
			Q.P.	AV.	Q.P.	AV.	Q.P.	AV.	Q.P.	AV.
1	0.150	0.10	55.62	-	55.72	-	66.00	56.00	-10.28	-
2	0.209	0.10	49.79	-	49.89	-	63.26	53.26	-13.37	-
3	0.267	0.11	42.17	-	42.28	-	61.20	51.20	-18.93	-
4	0.599	0.14	32.02	-	32.16	-	56.00	46.00	-23.84	-
5	3.270	0.29	34.23	-	34.52	-	56.00	46.00	-21.48	-
6	6.316	0.41	37.90	-	38.31	-	60.00	50.00	-21.69	-

- REMARKS:**
1. Q.P. and AV. are abbreviations of quasi-peak and average individually.
 2. "-": The Quasi-peak reading value also meets average limit and measurement with the average detector is unnecessary.
 3. The emission levels of other frequencies were very low against the limit.
 4. Margin value = Emission level - Limit value
 5. Correction factor = Insertion loss + Cable loss
 6. Emission Level = Correction Factor + Reading Value.

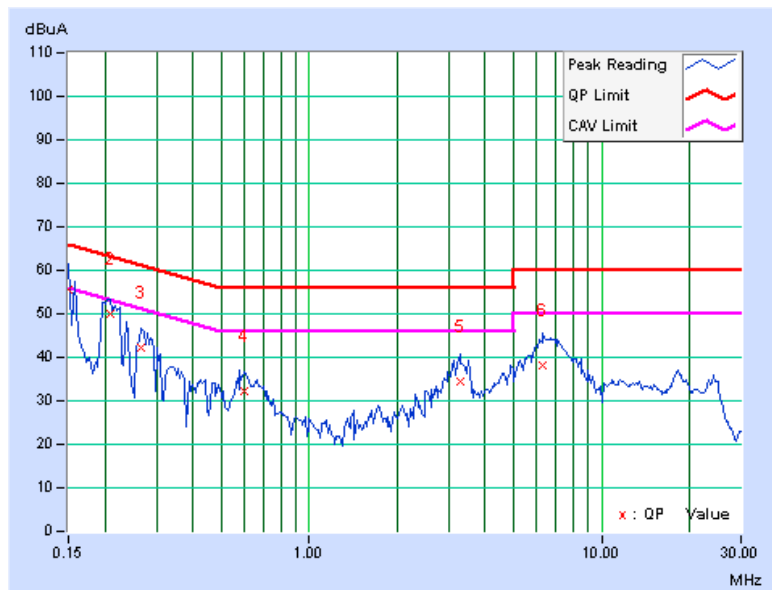



A D T

4.3 6dB BANDWIDTH MEASUREMENT

4.3.1 LIMITS OF 6dB BANDWIDTH MEASUREMENT

The minimum of 6dB Bandwidth Measurement is 0.5 MHz.

4.3.2 TEST INSTRUMENTS

DESCRIPTION & MANUFACTURER	MODEL NO.	SERIAL NO.	DATE OF CALIBRATION	DUE DATE OF CALIBRATION
SPECTRUM ANALYZER R&S	FSP40	100039	Jan. 11, 2010	Jan. 10, 2011

NOTE: The calibration interval of the above test instruments is 12 months and the calibrations are traceable to NML/ROC and NIST/USA.

4.3.3 TEST PROCEDURE

The transmitter output was connected to the spectrum analyzer through an attenuator. The bandwidth of the fundamental frequency was measured by spectrum analyzer with 100kHz RBW and 300kHz VBW. The 6dB bandwidth is defined as the total spectrum the power of which is higher than peak power minus 6dB.

4.3.4 DEVIATION FROM TEST STANDARD

No deviation

4.3.5 TEST SETUP

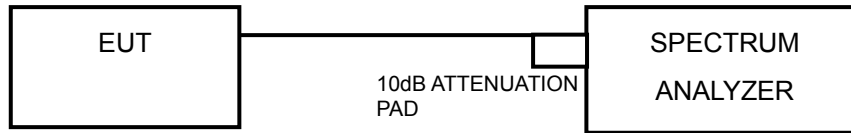

4.3.6 EUT OPERATING CONDITIONS

The software provided by client to enable the EUT under transmission condition continuously at lowest, middle and highest channel frequencies individually.



A D T

4.3.7 TEST RESULTS

802.11b

CHANNEL	CHANNEL FREQUENCY (MHz)	6dB BANDWIDTH (MHz)	MINIMUM LIMIT (MHz)	PASS / FAIL
1	2412	8.09	0.5	PASS
6	2437	8.11	0.5	PASS
11	2462	8.11	0.5	PASS

CH 11

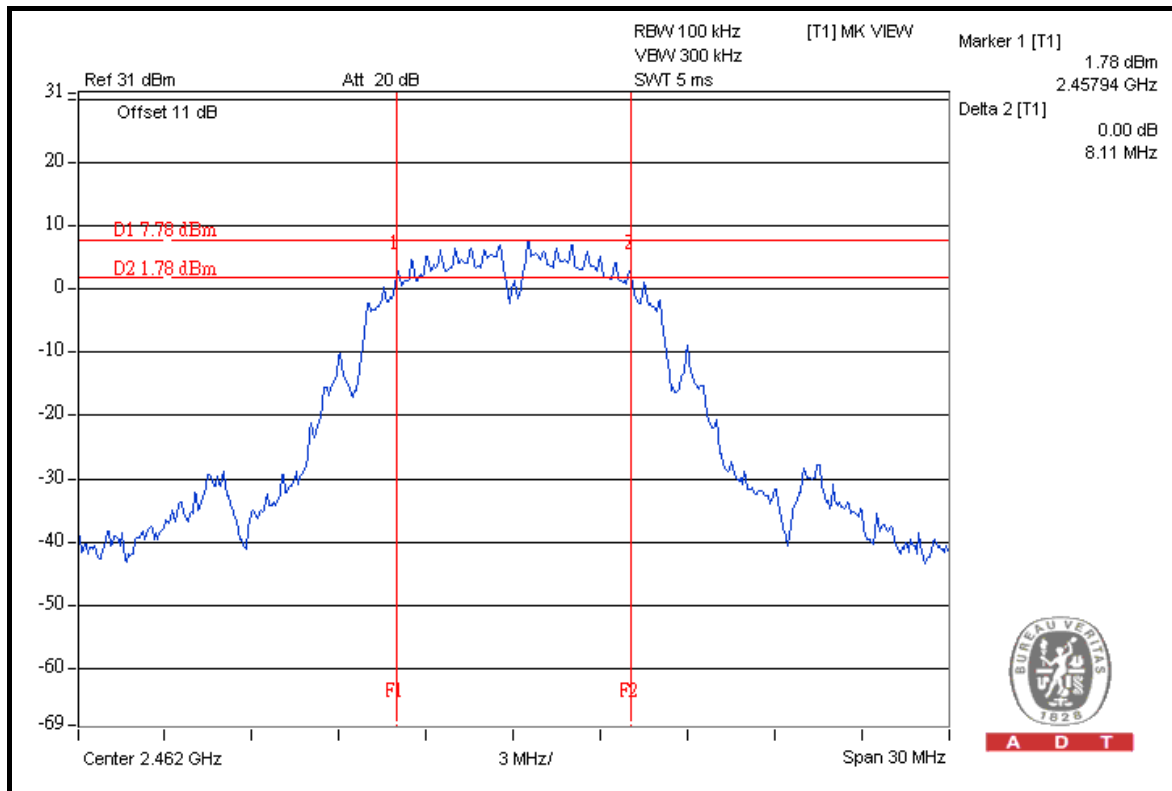



A D T

802.11g (Antenna A)

CHANNEL	CHANNEL FREQUENCY (MHz)	6dB BANDWIDTH (MHz)	MINIMUM LIMIT (MHz)	PASS / FAIL
1	2412	14.76	0.5	PASS
6	2437	15.09	0.5	PASS
11	2462	15.14	0.5	PASS

CH 11

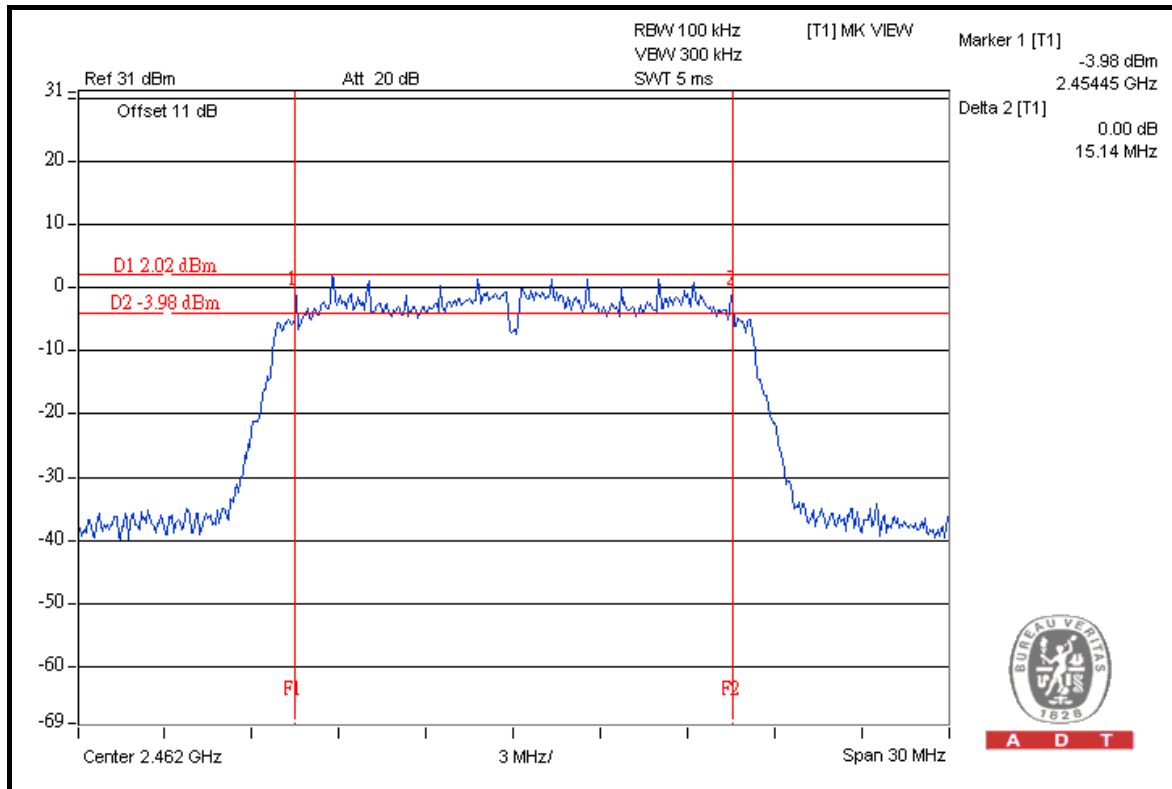



A D T

802.11g (Antenna B)

CHANNEL	CHANNEL FREQUENCY (MHz)	6dB BANDWIDTH (MHz)	MINIMUM LIMIT (MHz)	PASS / FAIL
1	2412	14.68	0.5	PASS
6	2437	14.49	0.5	PASS
11	2462	14.70	0.5	PASS

CH 11

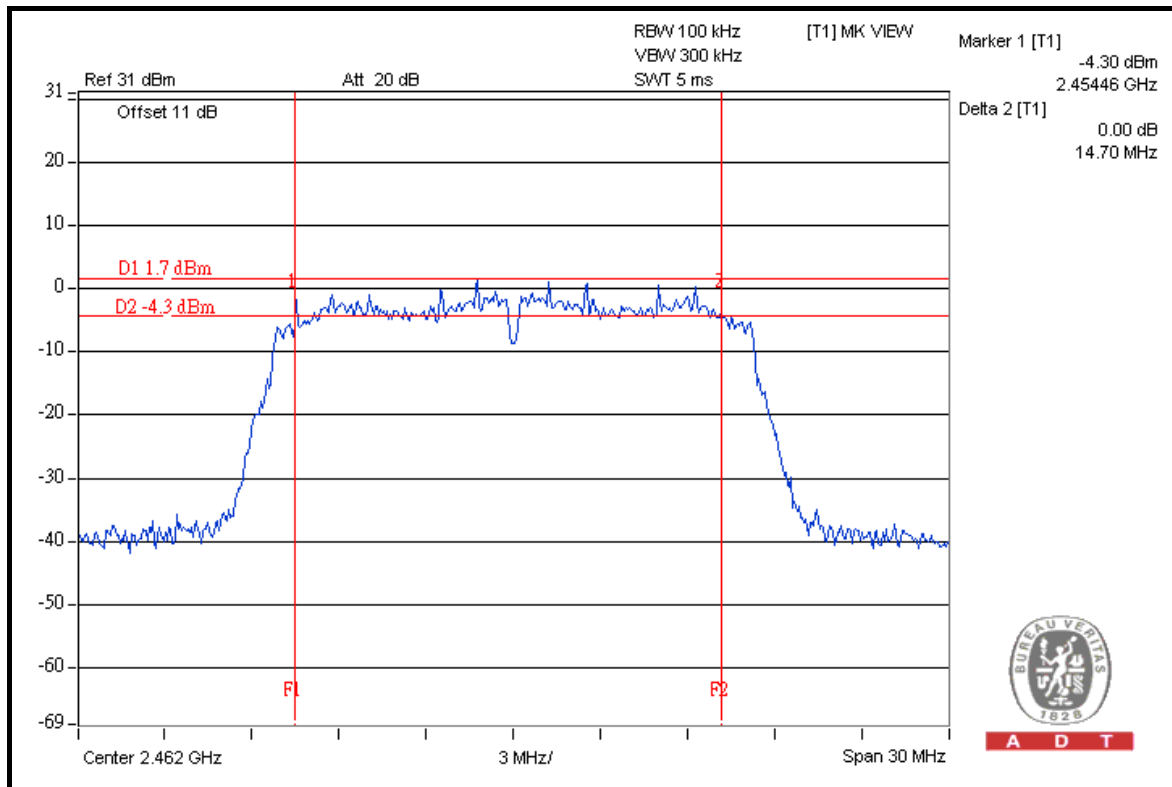



A D T

802.11n (20MHz)

CHANNEL	CHANNEL FREQUENCY (MHz)	6dB BANDWIDTH (MHz)		MINIMUM LIMIT (MHz)	PASS / FAIL
		CHAIN 0	CHAIN 1		
1	2412	15.20	16.28	0.5	PASS
6	2437	15.18	15.14	0.5	PASS
11	2462	15.15	16.39	0.5	PASS

FOR CHAIN 1: CH 11

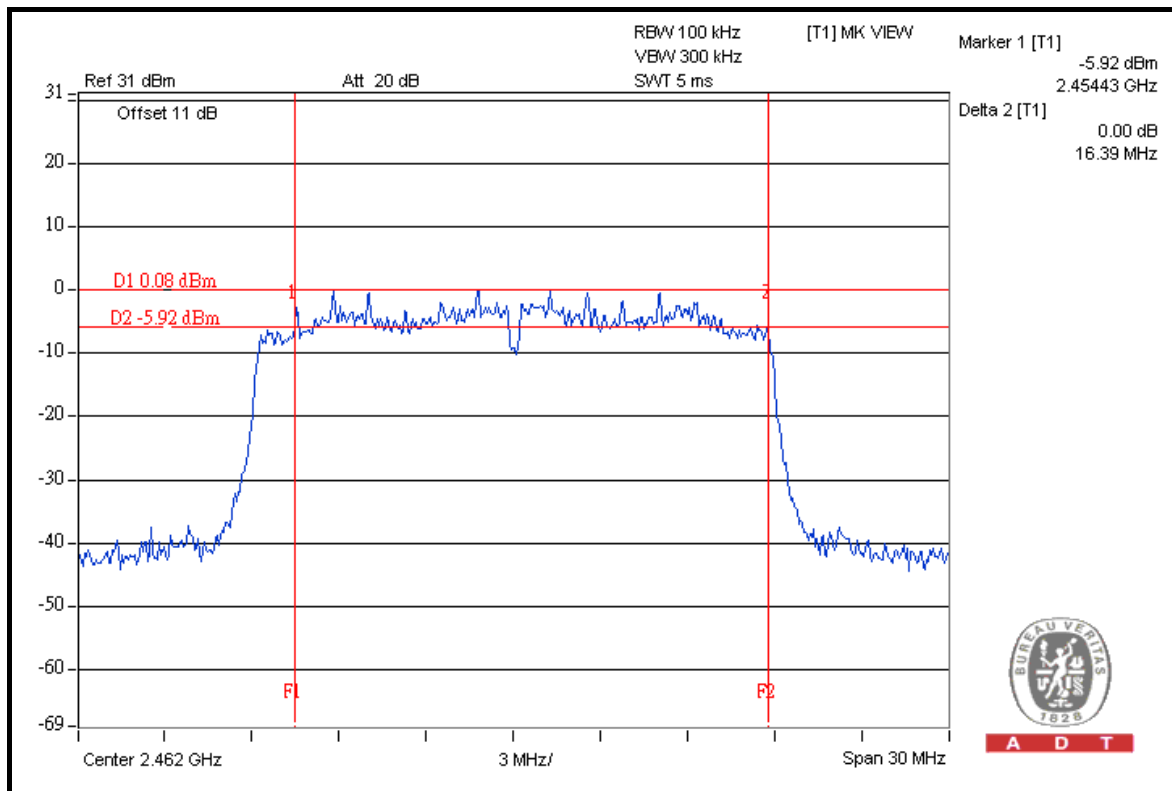



A D T

802.11n (40MHz)

CHANNEL	CHANNEL FREQUENCY (MHz)	6dB BANDWIDTH (MHz)		MINIMUM LIMIT (MHz)	PASS / FAIL
		CHAIN 0	CHAIN 1		
1	2422	35.78	35.44	0.5	PASS
4	2437	35.75	35.78	0.5	PASS
7	2452	34.24	35.24	0.5	PASS

FOR CHAIN 0: CH 1

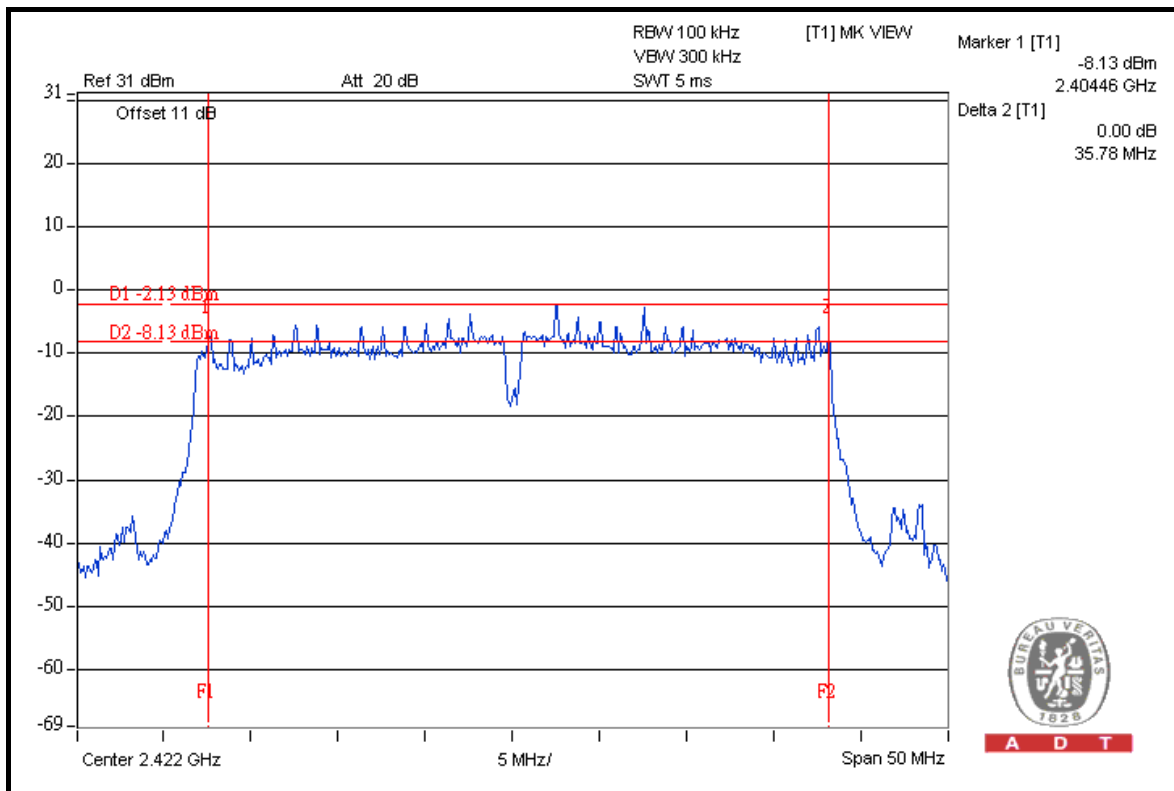



A D T

4.4 MAXIMUM OUTPUT POWER

4.4.1 LIMITS OF MAXIMUM OUTPUT POWER MEASUREMENT

The Maximum Output Power Measurement is 30dBm.

4.4.2 INSTRUMENTS

DESCRIPTION & MANUFACTURER	MODEL NO.	SERIAL NO.	DATE OF CALIBRATION	DUE DATE OF CALIBRATION
High Speed Peak Power Meter	ML2495A	0842014	Apr. 21, 2010	Apr. 20, 2011
Power Sensor	MA2411B	0738404	Apr. 21, 2010	Apr. 20, 2011

Note:

1. The calibration interval of the above test instruments is 12 months and the calibrations are traceable to NML/ROC and NIST/USA.
2. Measurement Bandwidth of ML2495A is 65MHz greater than 6dB bandwidth of emission.

4.4.3 TEST PROCEDURES

A power sensor was used on the output port of the EUT. A power meter was used to read the response of the power sensor. Record the power level.

4.4.4 DEVIATION FROM TEST STANDARD

No deviation

4.4.5 TEST SETUP

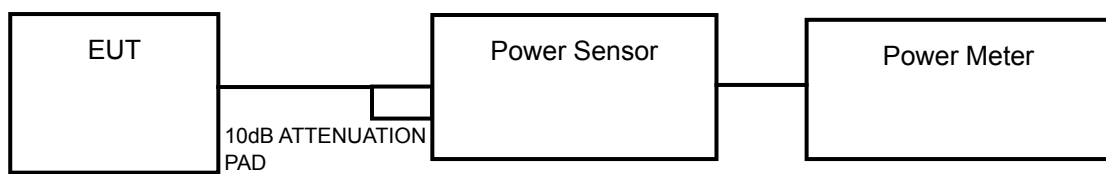

4.4.6 EUT OPERATING CONDITIONS

Same as Item 4.3.6



4.4.7 TEST RESULTS

802.11b

CHAN.	CHAN. FREQ. (MHz)	POWER OUTPUT (dBm)	POWER (mW)	POWER LIMIT (dBm)	PASS / FAIL
1	2412	20.5	112.2	30	PASS
6	2437	21.0	125.9	30	PASS
11	2462	21.1	128.8	30	PASS

802.11g (Antenna A)

CHAN.	CHAN. FREQ. (MHz)	POWER OUTPUT (dBm)	POWER (mW)	POWER LIMIT (dBm)	PASS / FAIL
1	2412	22.3	169.8	30	PASS
6	2437	22.2	166.0	30	PASS
11	2462	22.1	162.2	30	PASS

802.11g (Antenna B)

CHAN.	CHAN. FREQ. (MHz)	POWER OUTPUT (dBm)	POWER (mW)	POWER LIMIT (dBm)	PASS / FAIL
1	2412	22.0	158.5	30	PASS
6	2437	22.9	195.0	30	PASS
11	2462	21.8	151.4	30	PASS

802.11n (20MHz)

CHAN.	CHAN. FREQ. (MHz)	POWER OUTPUT (dBm)		TOTAL POWER (mW)	TOTAL POWER (dBm)	POWER LIMIT (dBm)	PASS / FAIL
		CHAIN 0	CHAIN 1				
1	2412	20.8	20.9	243.3	23.9	30	PASS
6	2437	21.4	22.1	300.2	24.8	30	PASS
11	2462	19.5	20.5	201.3	23.0	30	PASS

802.11n (40MHz)

CHAN.	CHAN. FREQ. (MHz)	POWER OUTPUT (dBm)		TOTAL POWER (mW)	TOTAL POWER (dBm)	POWER LIMIT (dBm)	PASS / FAIL
		CHAIN 0	CHAIN 1				
1	2422	18.9	20.1	180.0	22.6	30	PASS
4	2437	18.5	19.6	162.0	22.1	30	PASS
7	2452	18.1	20.1	166.9	22.2	30	PASS

4.5 POWER SPECTRAL DENSITY MEASUREMENT

4.5.1 LIMITS OF POWER SPECTRAL DENSITY MEASUREMENT

The Maximum of Power Spectral Density Measurement is 8dBm.

4.5.2 TEST INSTRUMENTS

DESCRIPTION & MANUFACTURER	MODEL NO.	SERIAL NO.	DATE OF CALIBRATION	DUE DATE OF CALIBRATION
SPECTRUM ANALYZER R&S	FSP40	100039	Jan. 11, 2010	Jan. 10, 2011

NOTE: The calibration interval of the above test instruments is 12 months and the calibrations are traceable to NML/ROC and NIST/USA.

4.5.3 TEST PROCEDURE

The transmitter output was connected to the spectrum analyzer through an attenuator, the bandwidth of the fundamental frequency was measured with the spectrum analyzer using 3kHz RBW and 30kHz VBW, set sweep time = span/3kHz. The power spectral density was measured and recorded.

The sweep time is allowed to be longer than span/3kHz for a full response of the mixer in the spectrum analyzer.

4.5.4 DEVIATION FROM TEST STANDARD

No deviation

4.5.5 TEST SETUP

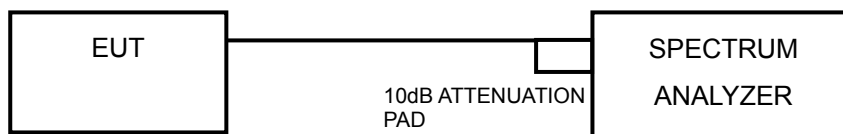

4.5.6 EUT OPERATING CONDITION

Same as Item 4.3.6



A D T

4.5.7 TEST RESULTS

802.11b

CHANNEL	CHANNEL FREQUENCY (MHz)	RF POWER LEVEL IN 3 kHz BW (dBm)	MAXIMUM LIMIT (dBm)	PASS/FAIL
1	2412	-6.1	8	PASS
6	2437	-5.7	8	PASS
11	2462	-5.3	8	PASS

CH 11

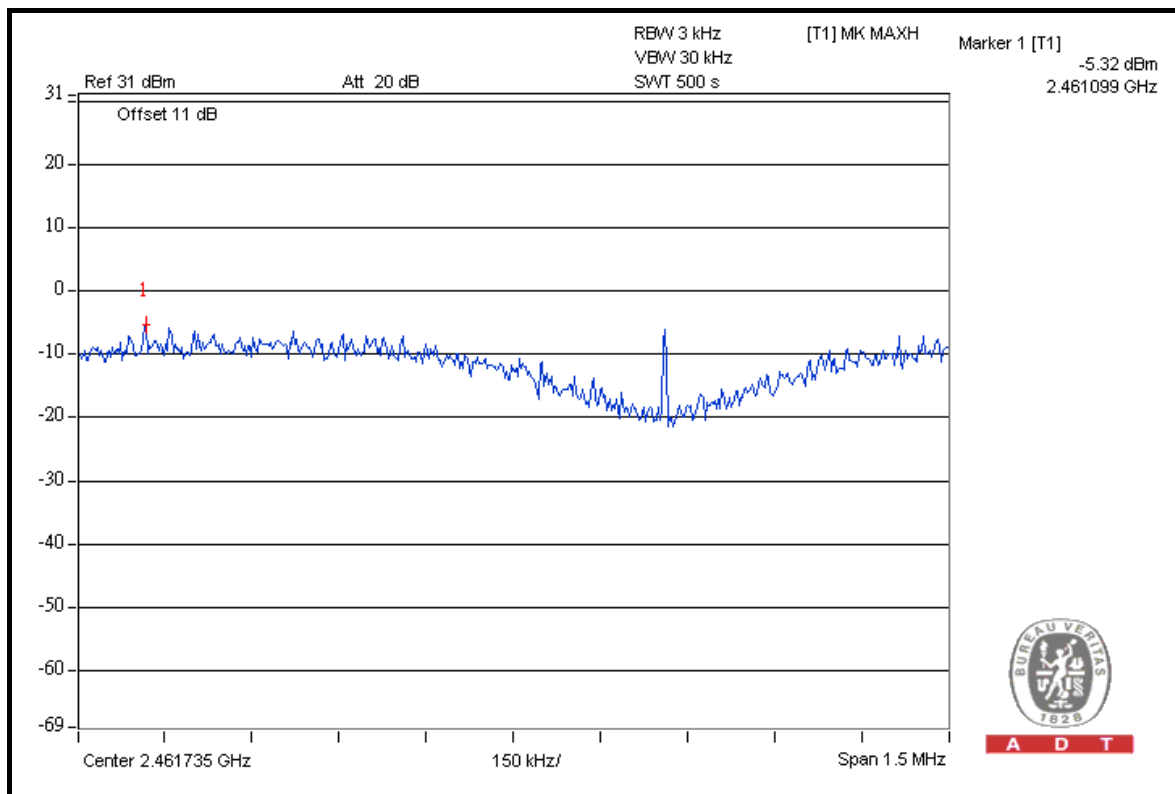



A D T

802.11g (Antenna A)

CHANNEL	CHANNEL FREQUENCY (MHz)	RF POWER LEVEL IN 3 kHz BW (dBm)	MAXIMUM LIMIT (dBm)	PASS/FAIL
1	2412	-11.2	8	PASS
6	2437	-11.2	8	PASS
11	2462	-11.1	8	PASS

CH 11

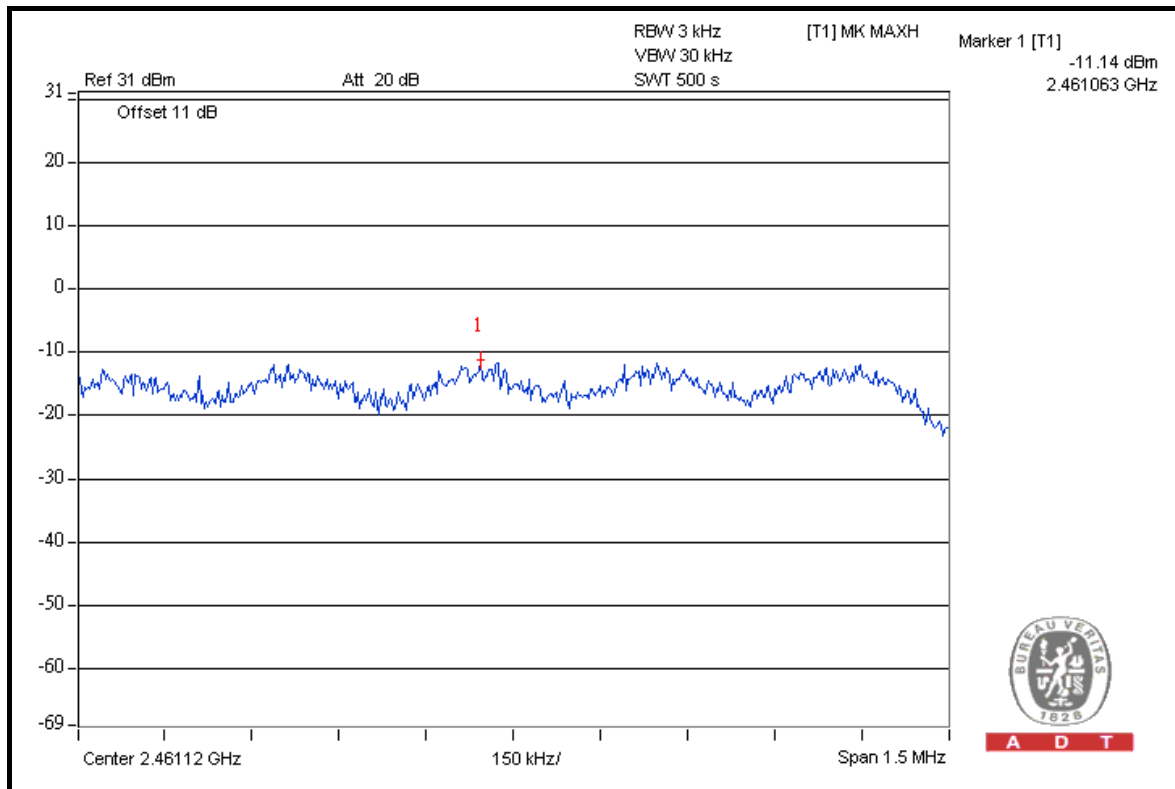



A D T

802.11g (Antenna B)

CHANNEL	CHANNEL FREQUENCY (MHz)	RF POWER LEVEL IN 3 kHz BW (dBm)	MAXIMUM LIMIT (dBm)	PASS/FAIL
1	2412	-11.3	8	PASS
6	2437	-10.6	8	PASS
11	2462	-11.4	8	PASS

CH 6

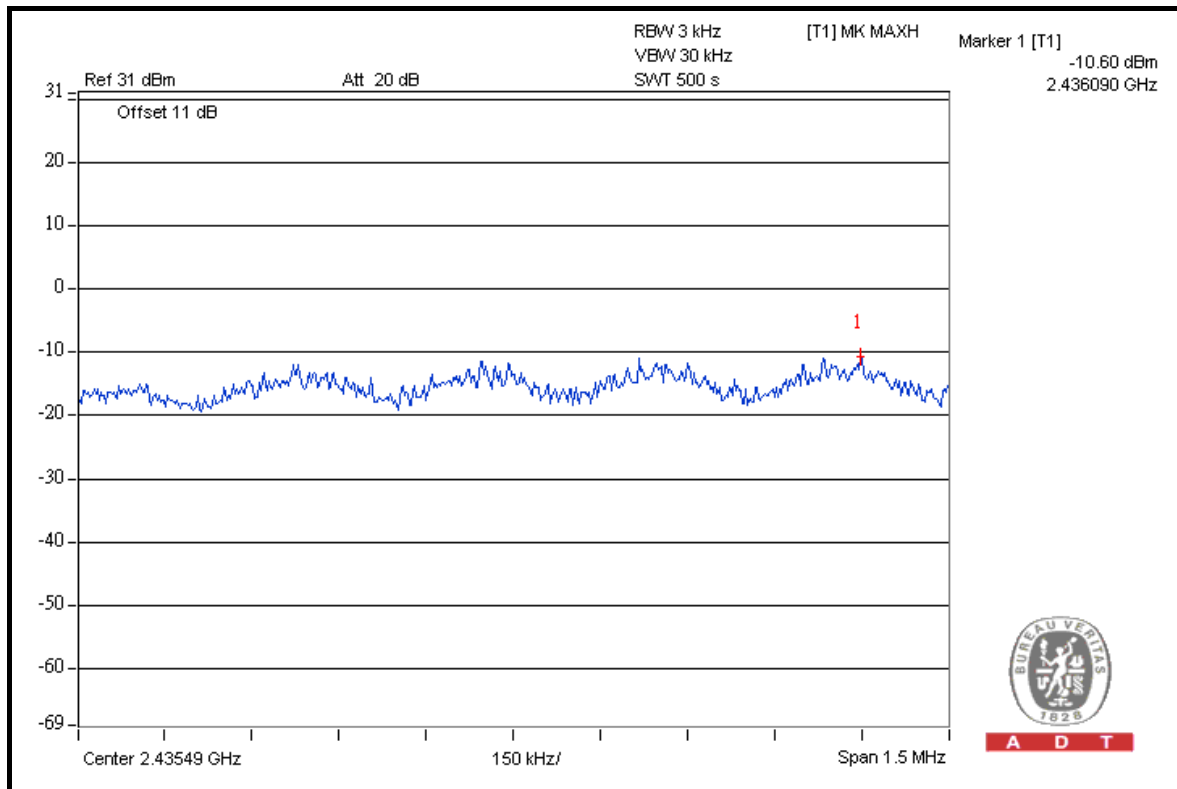



A D T

802.11n (20MHz)

CHAN.	CHAN. FREQ. (MHz)	RF POWER LEVEL IN 3kHz BW (dBm)		TOTAL POWER DENSITY (dBm)	MAX. LIMIT (dBm)	PASS / FAIL
		CHAIN 0	CHAIN 1			
1	2412	-14.1	-13.6	-10.8	8	PASS
6	2437	-13.7	-12.3	-9.9	8	PASS
11	2462	-15.4	-13.8	-11.5	8	PASS

FOR CHAIN 1: CH 6

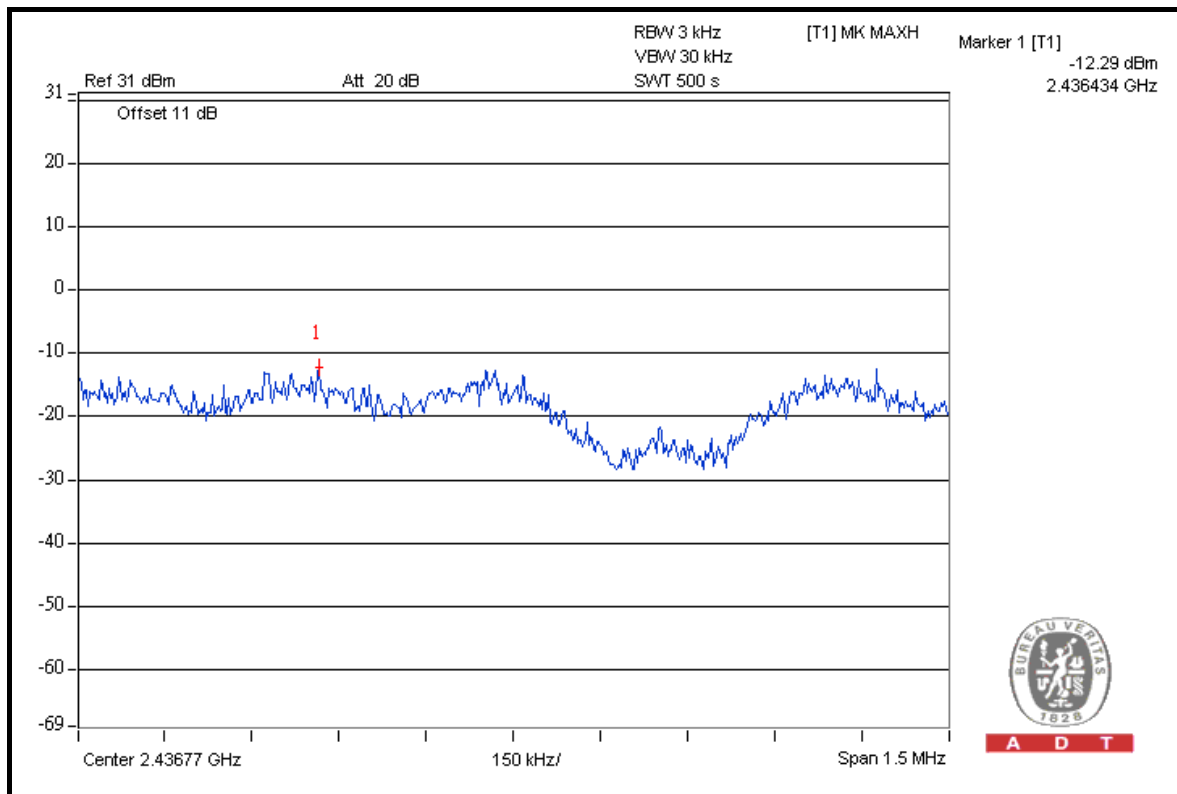



A D T

802.11n (40MHz)

CHAN.	CHAN. FREQ. (MHz)	RF POWER LEVEL IN 3kHz BW (dBm)		TOTAL POWER DENSITY (dBm)	MAX. LIMIT (dBm)	PASS / FAIL
		CHAIN 0	CHAIN 1			
1	2422	-16.3	-14.6	-12.4	8	PASS
4	2437	-16.7	-15.0	-12.8	8	PASS
7	2452	-17.1	-14.8	-12.8	8	PASS

FOR CHAIN 1: CH 1

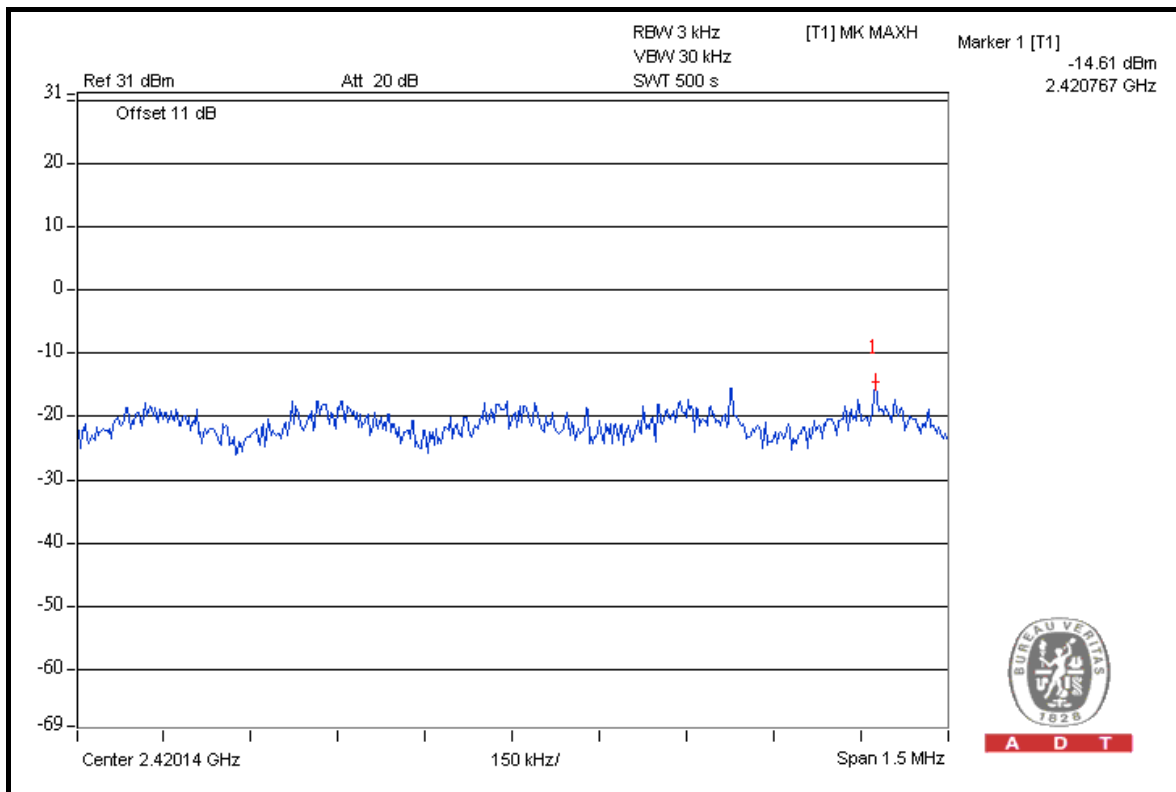



A D T

4.6 BAND EDGES MEASUREMENT

4.6.1 LIMITS OF BAND EDGES MEASUREMENT

Below -20dB of the highest emission level of operating band (in 100kHz Resolution Bandwidth).

4.6.2 TEST INSTRUMENTS

DESCRIPTION & MANUFACTURER	MODEL NO.	SERIAL NO.	DATE OF CALIBRATION	CALIBRATED UNTIL
FOR CONDUCTED MEASUREMENT				
SPECTRUM ANALYZER R&S	FSP40	100039	Jan. 11, 2010	Jan. 10, 2011
FOR RADIATED MEASUREMENT				
Test Receiver ROHDE & SCHWARZ	ESIB7	100188	Dec. 21, 2009	Dec. 20, 2010
Spectrum Analyzer ROHDE & SCHWARZ	FSP40	100041	Jul. 09, 2010	Jul. 08, 2011
BILOG Antenna SCHWARZBECK	VULB9168	9168-156	Apr. 30, 2010	Apr. 29, 2011
HORN Antenna SCHWARZBECK	BBHA 9120 D	9120D-209	Aug. 02, 2010	Aug. 01, 2011
HORN Antenna SCHWARZBECK	BBHA 9170	BBHA9170242	Dec. 25, 2009	Dec. 24, 2010
Preamplifier Agilent	8447D	2944A10629	Nov. 04, 2009	Nov. 03, 2010
Preamplifier Agilent	8449B	3008A01959	Dec. 10, 2009	Dec. 09, 2010
RF signal cable HUBER+SUHNNER	SUCOFLEX 104	238141/4	May 14, 2010	May 13, 2011
RF signal cable HUBER+SUHNNER	SUCOFLEX 104	12738/6	May 14, 2010	May 13, 2011
Software	ADT_Radiated_V7.6.15.9.2	NA	NA	NA
Antenna Tower EMCO	2070/2080	512.835.4684	NA	NA
Turn Table EMCO	2087-2.03	NA	NA	NA
Antenna Tower & Turn Table Controller EMCO	2090	NA	NA	NA

NOTE: The calibration interval of the above test instruments is 12 months and the calibrations are traceable to NML/ROC and NIST/USA.



A D T

4.6.3 TEST PROCEDURE

FOR CONDUCTED MEASUREMENT

The transmitter output was connected to the spectrum analyzer via a low loss cable. Set both RBW and VBW of spectrum analyzer to 100kHz and 300kHz with suitable frequency span including 100MHz bandwidth from band edge. The band edges was measured and recorded.

The spectrum plots (Peak RBW = 100kHz, VBW = 300kHz; Average RBW = 1MHz, VBW = 10Hz) are attached on the following pages.

FOR RADIATED MEASUREMENT

- a. The EUT was placed on the top of a rotating table 0.8 meters above the ground at a 3 meter semi-anechoic chamber. The table was rotated 360 degrees to determine the position of the highest radiation.
- b. The EUT was set 3 meters away from the interference-receiving antenna, which was mounted on the top of a variable-height antenna tower.
- c. The antenna is a broadband antenna, and its height is varied from one meter to four meters above the ground to determine the maximum value of the field strength. Both horizontal and vertical polarizations of the antenna are set to make the measurement.
- d. For each suspected emission, the EUT was arranged to its worst case and then the antenna was tuned to heights from 1 meter to 4 meters and the rotatable table was turned from 0 degrees to 360 degrees to find the maximum reading.
- e. Set both RBW and VBW of spectrum analyzer to 100kHz and 300kHz with suitable frequency span including 100MHz bandwidth from band edge. The band edges was measured and recorded.

The spectrum plots (Peak RBW = 100kHz, VBW = 300kHz) are attached on the following pages.

NOTE: The resolution bandwidth of test receiver/spectrum analyzer is 1MHz and the video bandwidth is 10Hz for Average detection (AV) at frequency above 1GHz.

4.6.4 DEVIATION FROM TEST STANDARD

No deviation

4.6.5 EUT OPERATING CONDITION

Same as Item 4.3.6



4.6.6 TEST RESULTS

The spectrum plots are attached on the following pages. D1 line indicates the highest level, and D2 line indicates the 20dB offset below D1. It shows compliance with the requirement in part 15.247(d).

802.11b

RESTRICT BAND (2310 ~ 2390 MHz)

FREQUENCY (MHz)	FUNDAMENTAL EMISSION (dBuV/m)	DELTA (dB)	MAXIMUM FIELD STRENGTH IN RESTRICT BAND (dBuV/m)	LIMIT (dBuV/m)
2412.00 (PK)	107.0	54.24	52.76	74.00
2412.00 (AV)	102.9	59.55	43.35	54.00

RESTRICT BAND (2483.5 ~ 2500 MHz)

FREQUENCY (MHz)	FUNDAMENTAL EMISSION (dBuV/m)	DELTA (dB)	MAXIMUM FIELD STRENGTH IN RESTRICT BAND (dBuV/m)	LIMIT (dBuV/m)
2462.00 (PK)	106.8	54.17	52.63	74.00
2462.00 (AV)	102.6	58.56	44.04	54.00

NOTE:

1. Delta = Amplitude between the peak of the fundamental and the peak of the band edge emission. Please check following 3 pages.
2. Maximum field strength in restrict band = Fundamental emission – Delta.



A D T

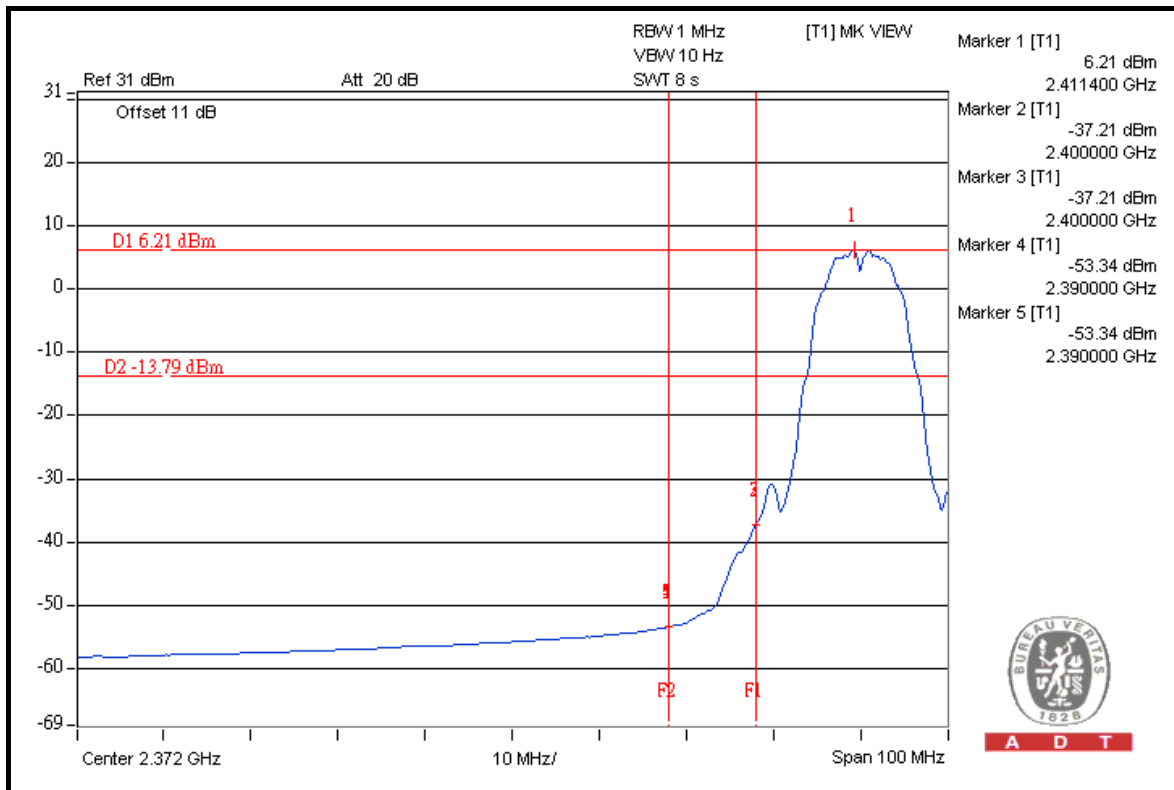
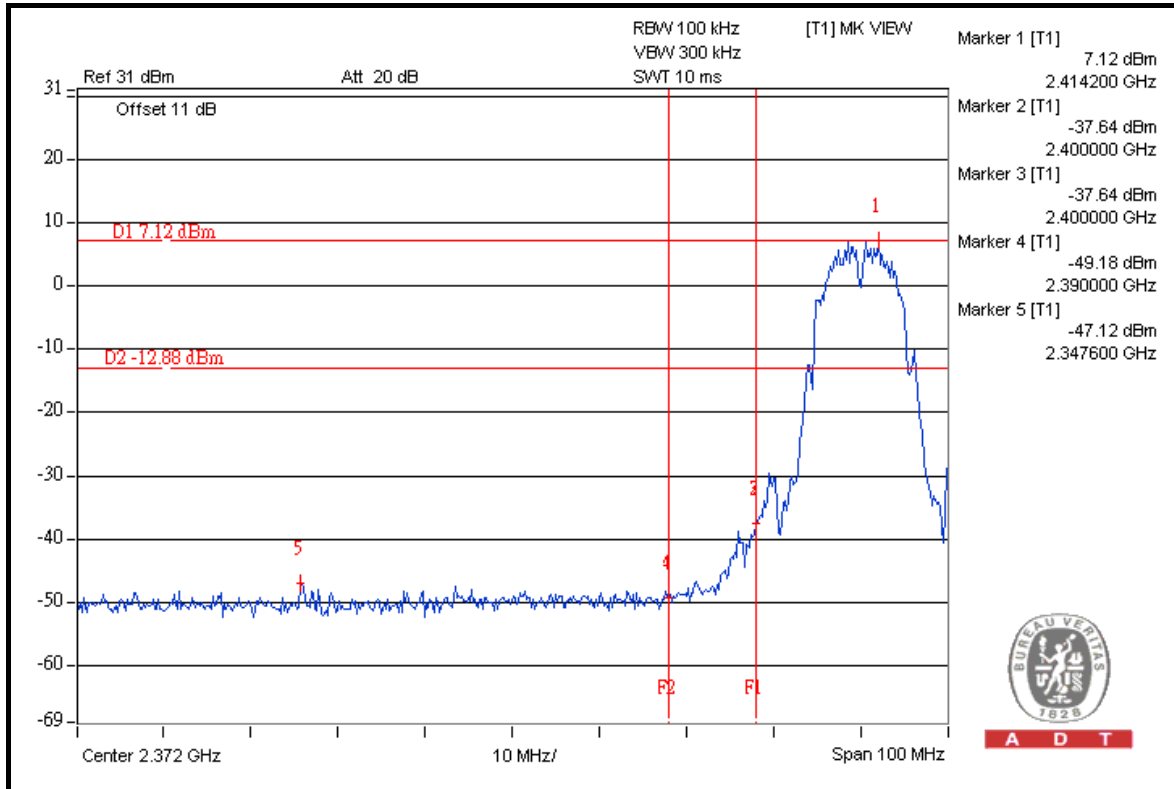



A D T

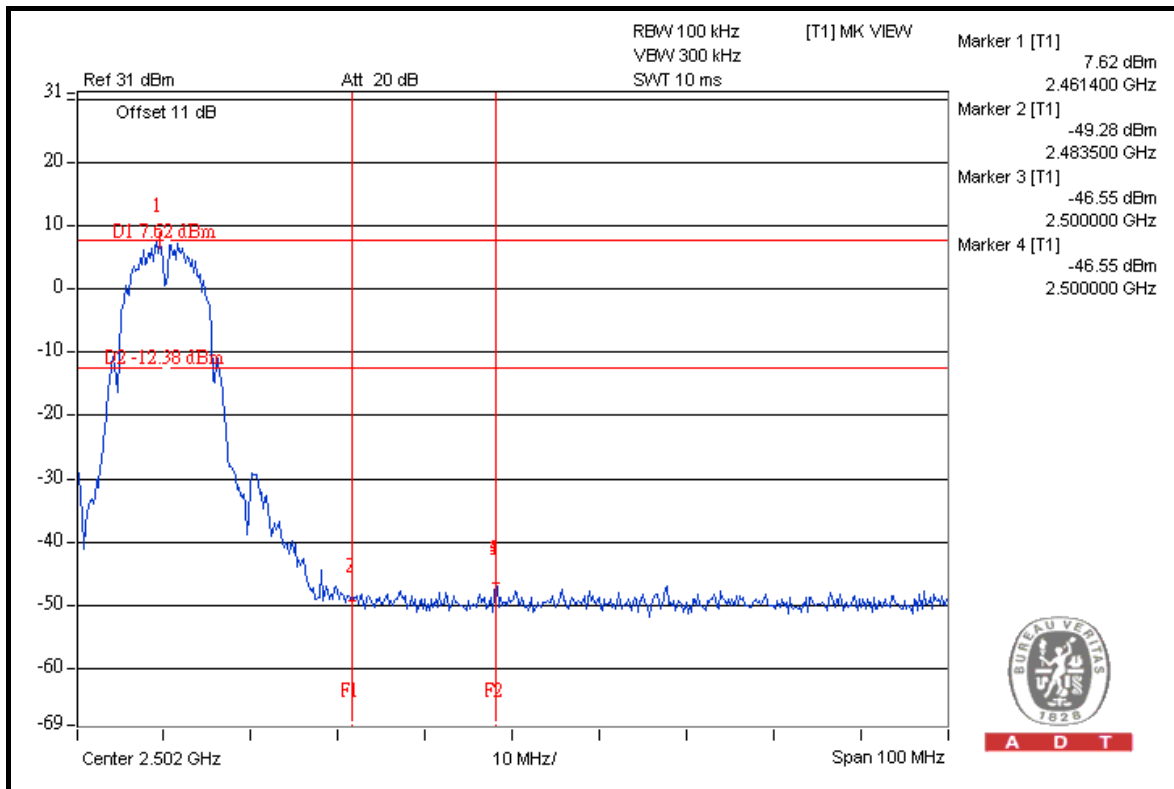
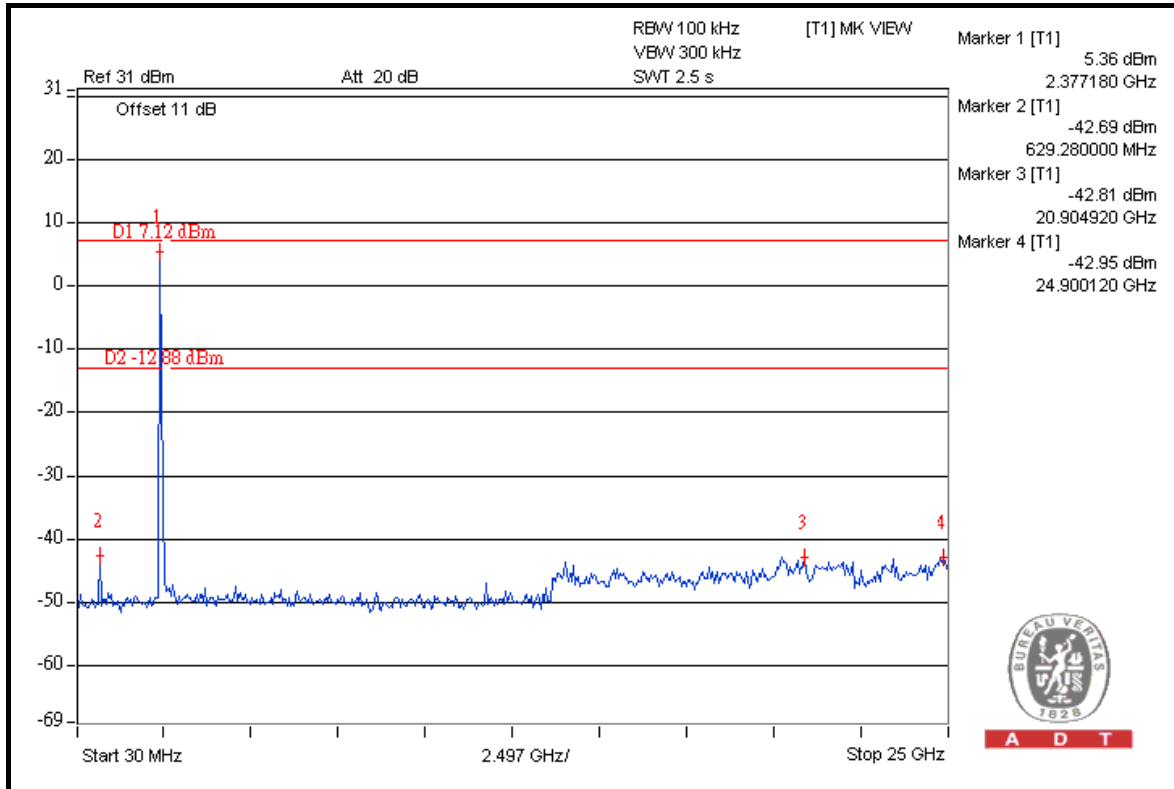



A D T

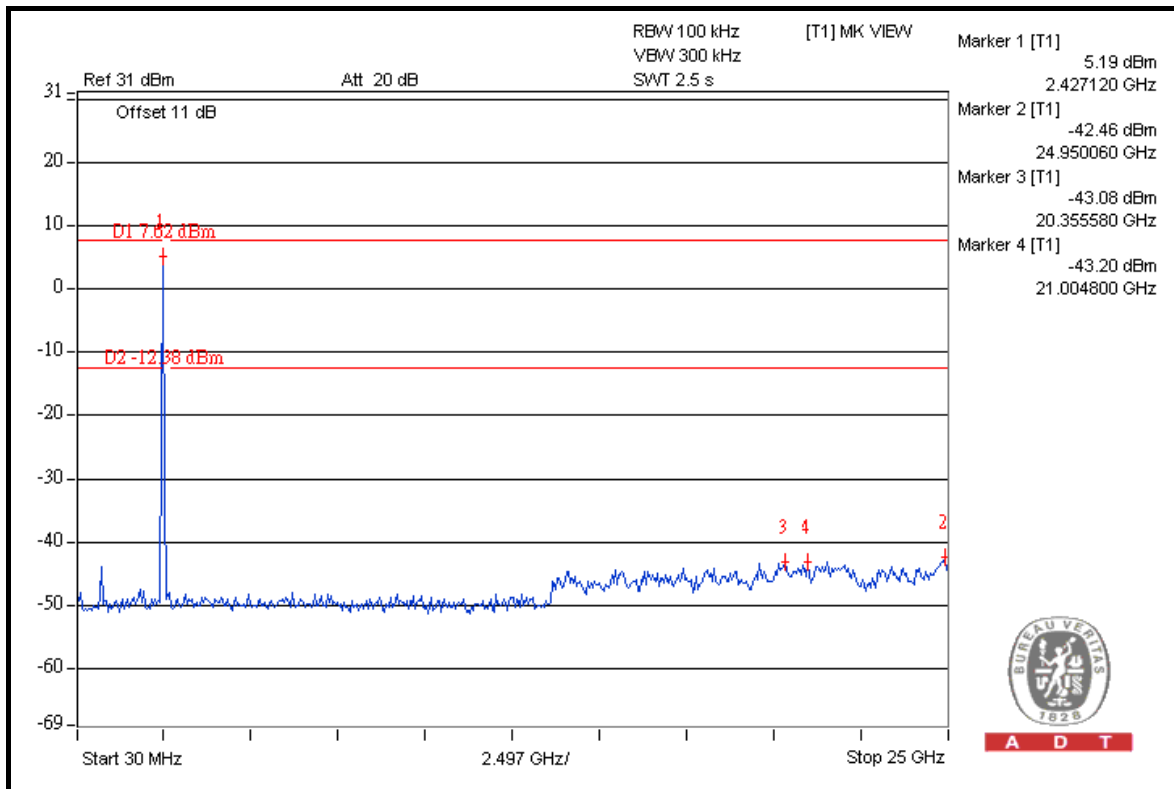
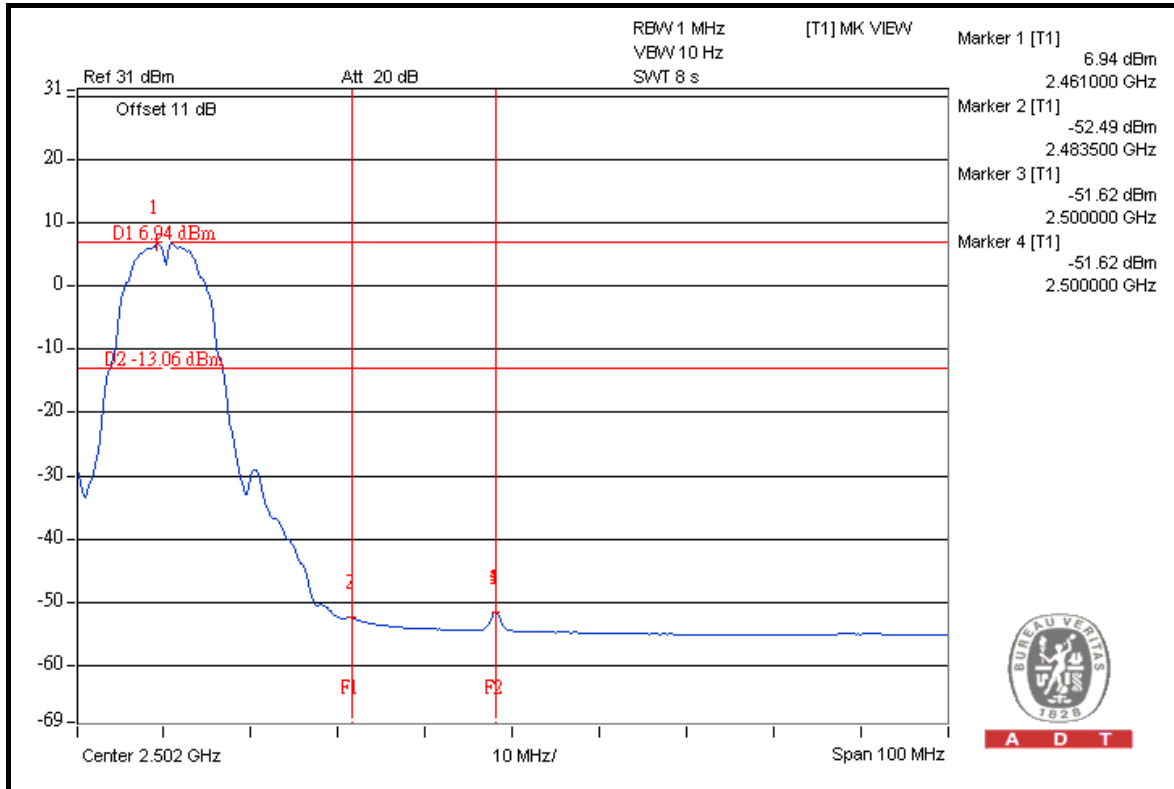



A D T

802.11g (Antenna A)

RESTRICT BAND (2310 ~ 2390 MHz)

FREQUENCY (MHz)	FUNDAMENTAL EMISSION (dBuV/m)	DELTA (dB)	MAXIMUM FIELD STRENGTH IN RESTRICT BAND (dBuV/m)	LIMIT (dBuV/m)
2412.00 (PK)	106.3	44.84	61.46	74.00
2412.00 (AV)	95.1	44.11	50.99	54.00

RESTRICT BAND (2483.5 ~ 2500 MHz)

FREQUENCY (MHz)	FUNDAMENTAL EMISSION (dBuV/m)	DELTA (dB)	MAXIMUM FIELD STRENGTH IN RESTRICT BAND (dBuV/m)	LIMIT (dBuV/m)
2462.00 (PK)	105.6	43.45	62.15	74.00
2462.00 (AV)	94.5	42.87	51.63	54.00

NOTE:

1. Delta = Amplitude between the peak of the fundamental and the peak of the band edge emission. Please check following 3 pages.
2. Maximum field strength in restrict band = Fundamental emission – Delta.



A D T

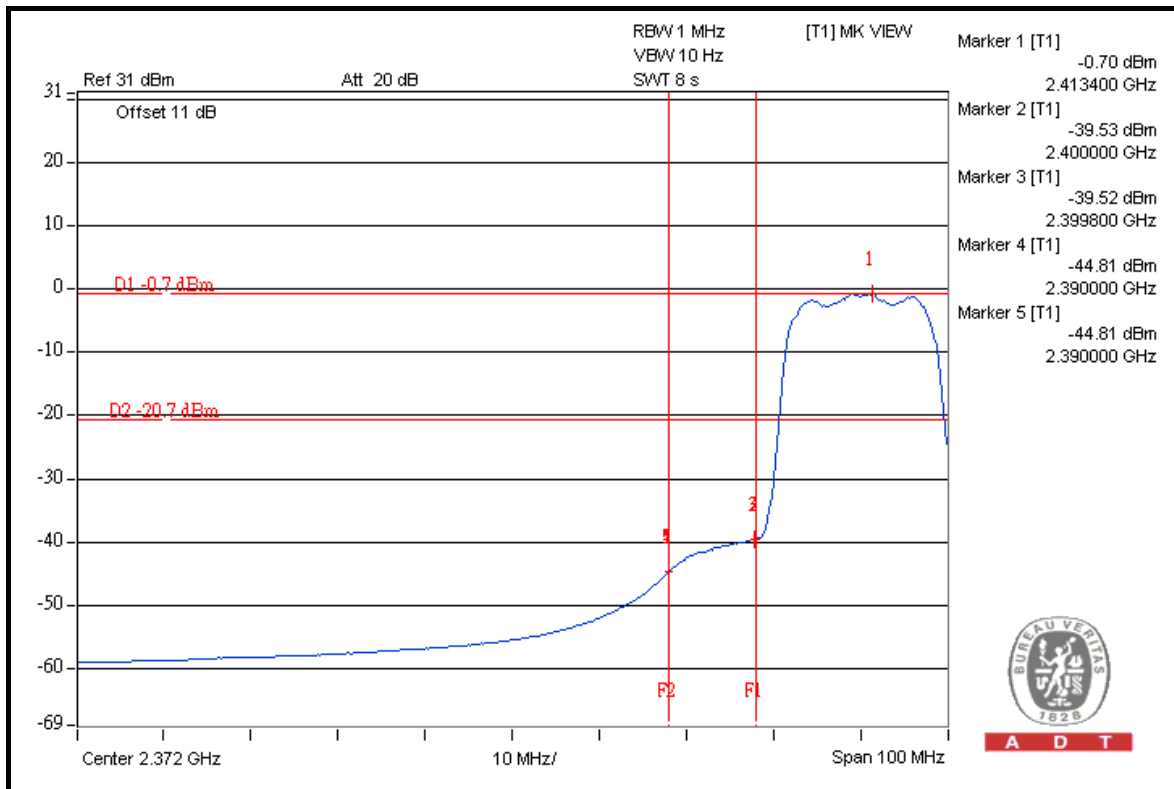
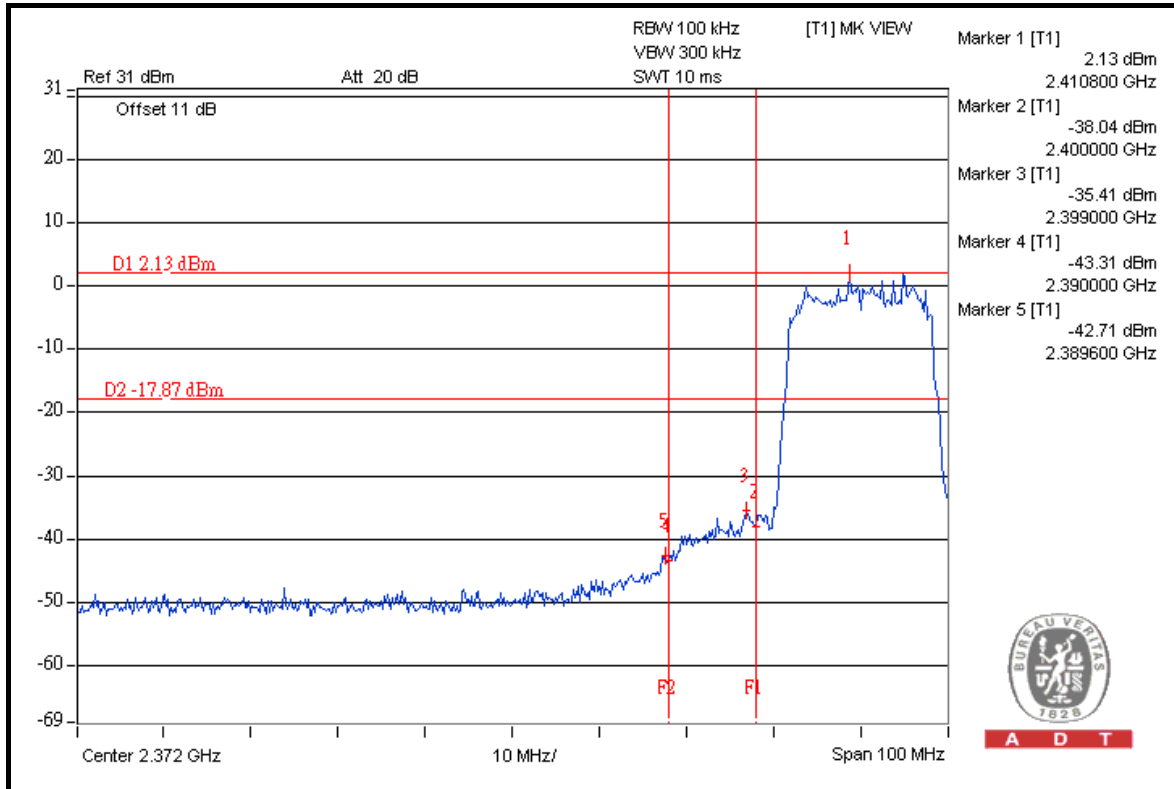



A D T

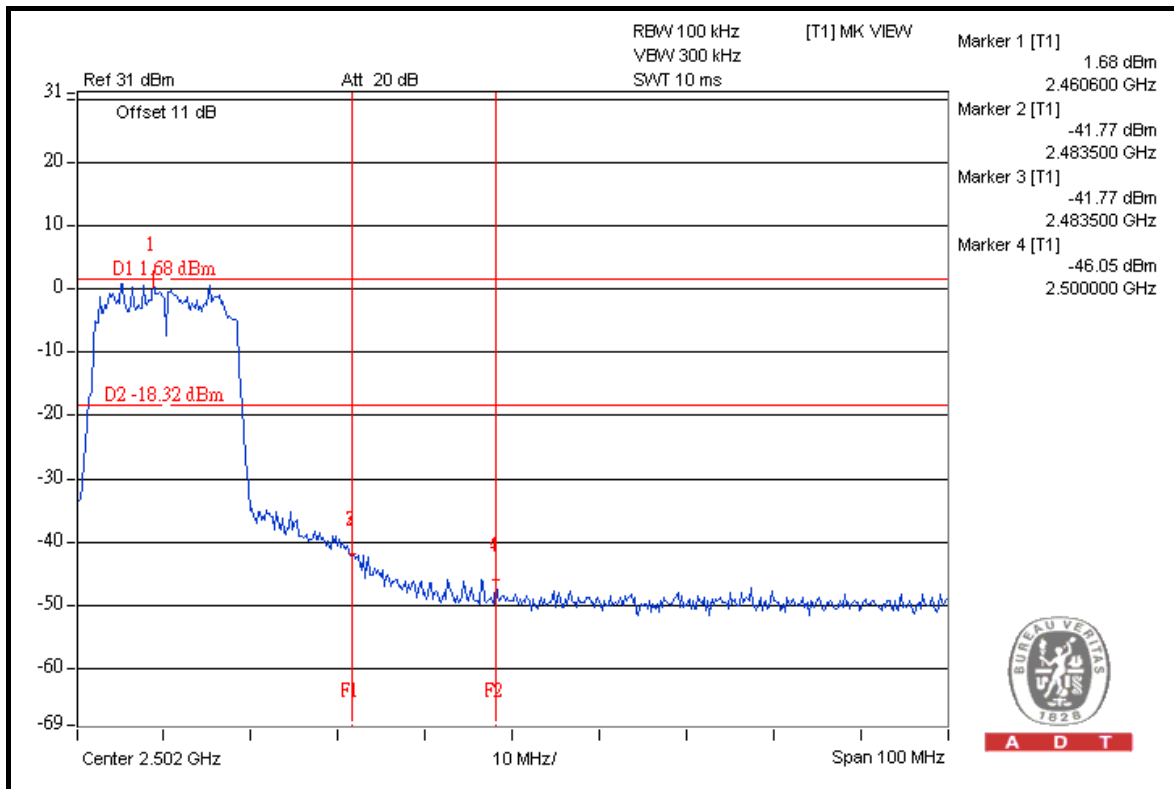
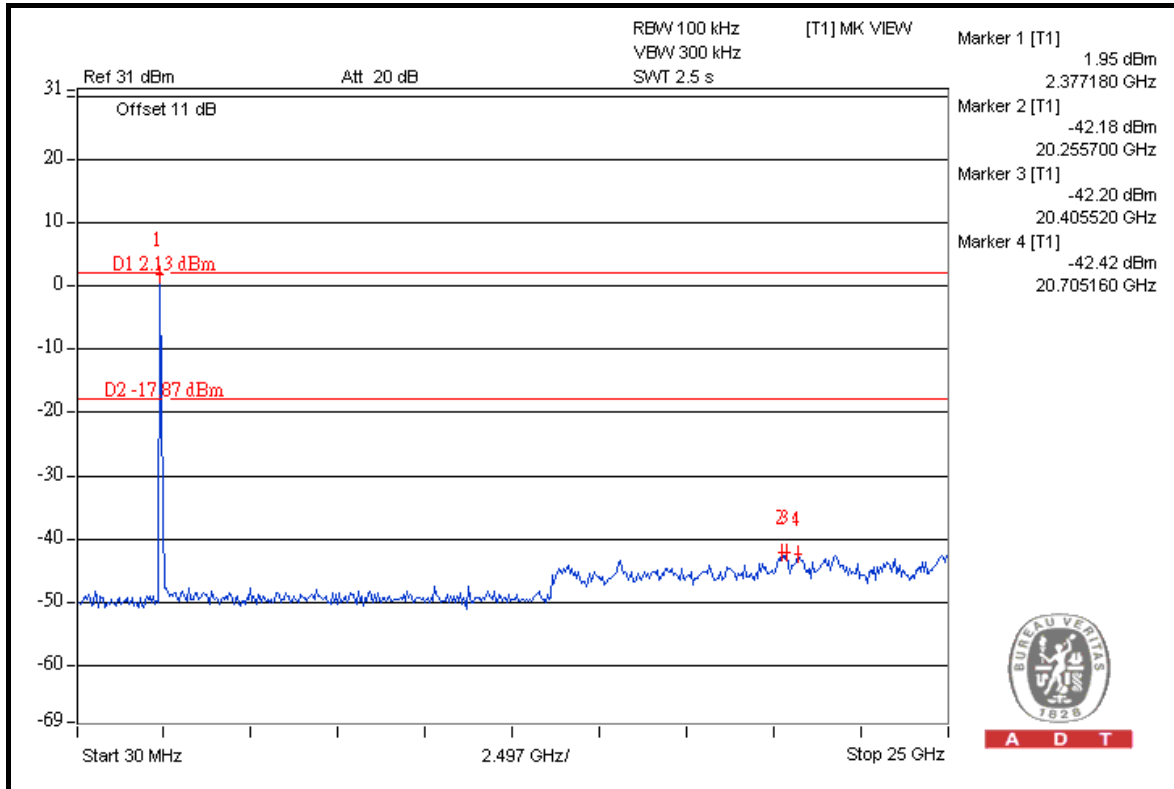



A D T

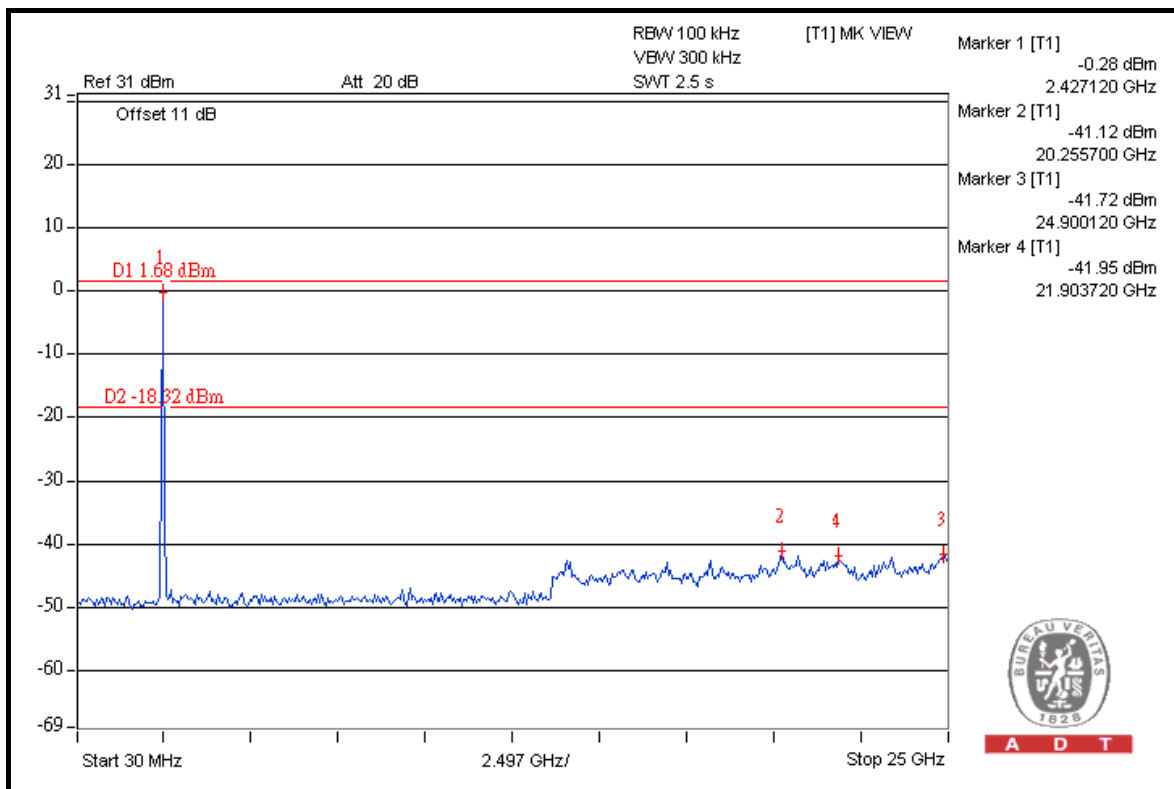
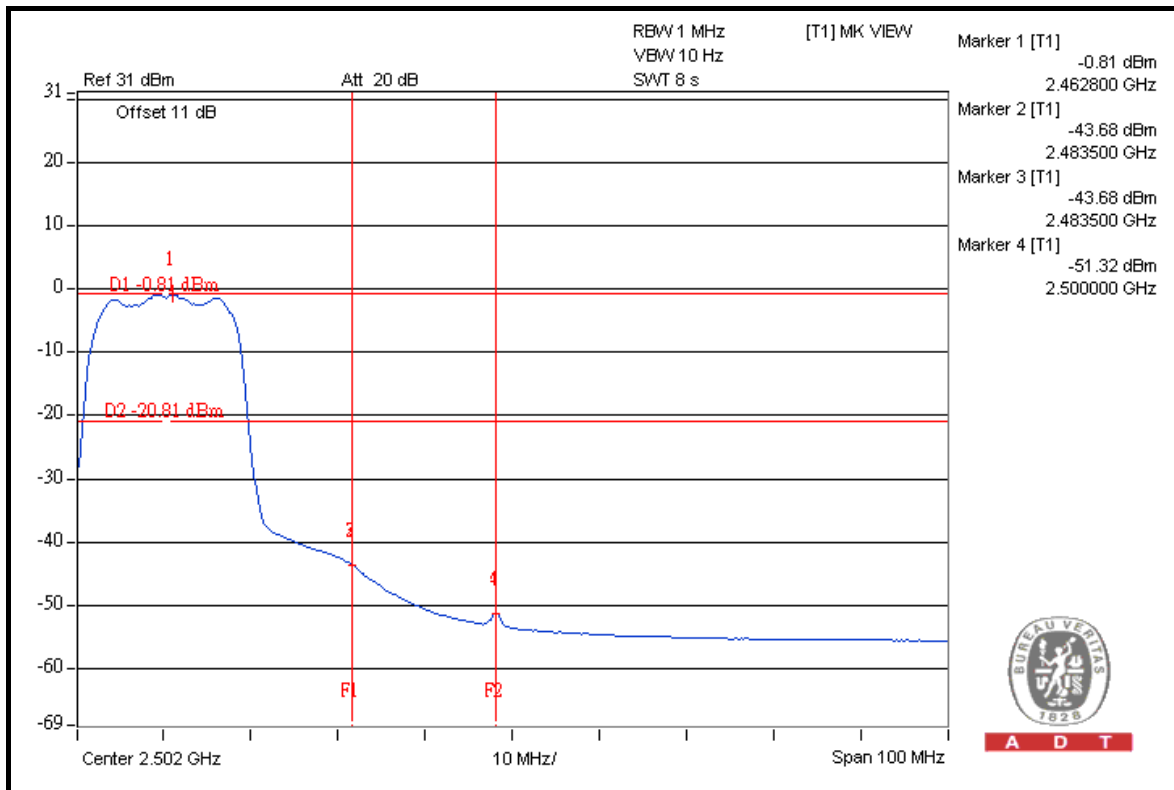



A D T

802.11g (Antenna B)

RESTRICT BAND (2310 ~ 2390 MHz)

FREQUENCY (MHz)	FUNDAMENTAL EMISSION (dBuV/m)	DELTA (dB)	MAXIMUM FIELD STRENGTH IN RESTRICT BAND (dBuV/m)	LIMIT (dBuV/m)
2412.00 (PK)	108.9	44.25	64.65	74.00
2412.00 (AV)	97.8	45.10	52.70	54.00

RESTRICT BAND (2483.5 ~ 2500 MHz)

FREQUENCY (MHz)	FUNDAMENTAL EMISSION (dBuV/m)	DELTA (dB)	MAXIMUM FIELD STRENGTH IN RESTRICT BAND (dBuV/m)	LIMIT (dBuV/m)
2462.00 (PK)	108.3	42.97	65.33	74.00
2462.00 (AV)	97.1	44.49	52.61	54.00

NOTE:

1. Delta = Amplitude between the peak of the fundamental and the peak of the band edge emission. Please check following 3 pages.
2. Maximum field strength in restrict band = Fundamental emission – Delta.



A D T

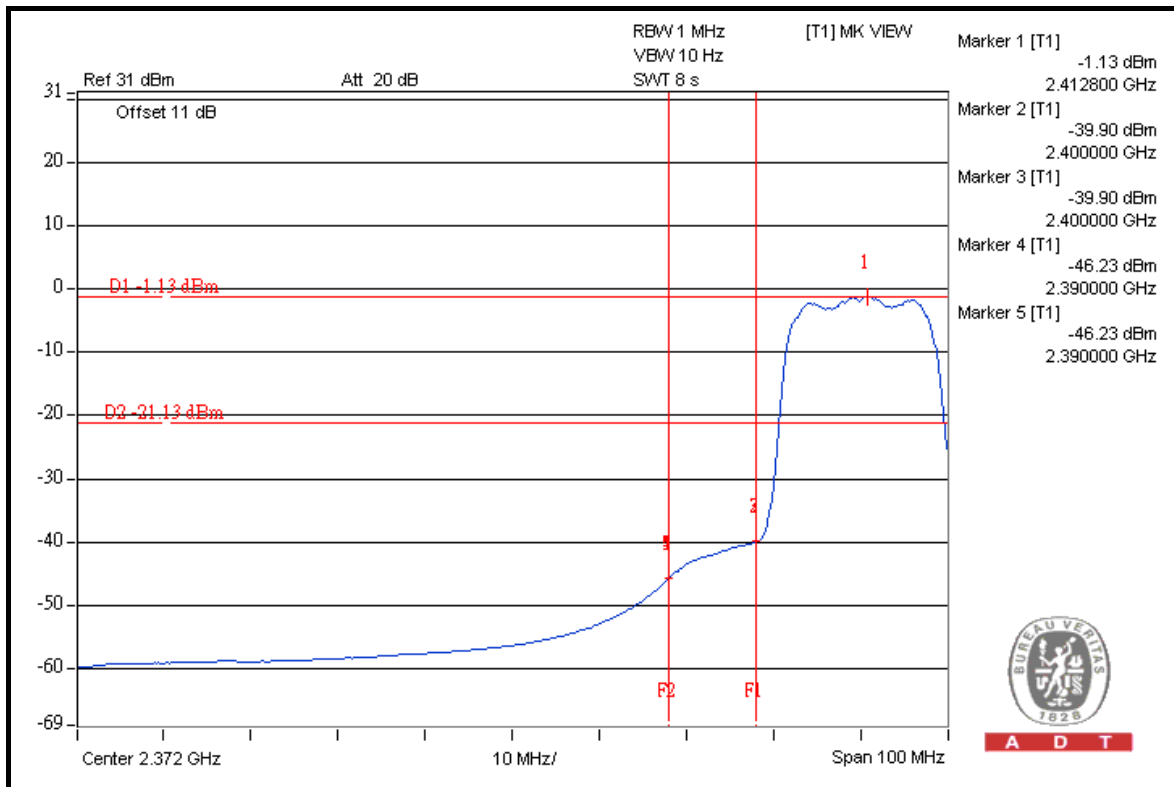
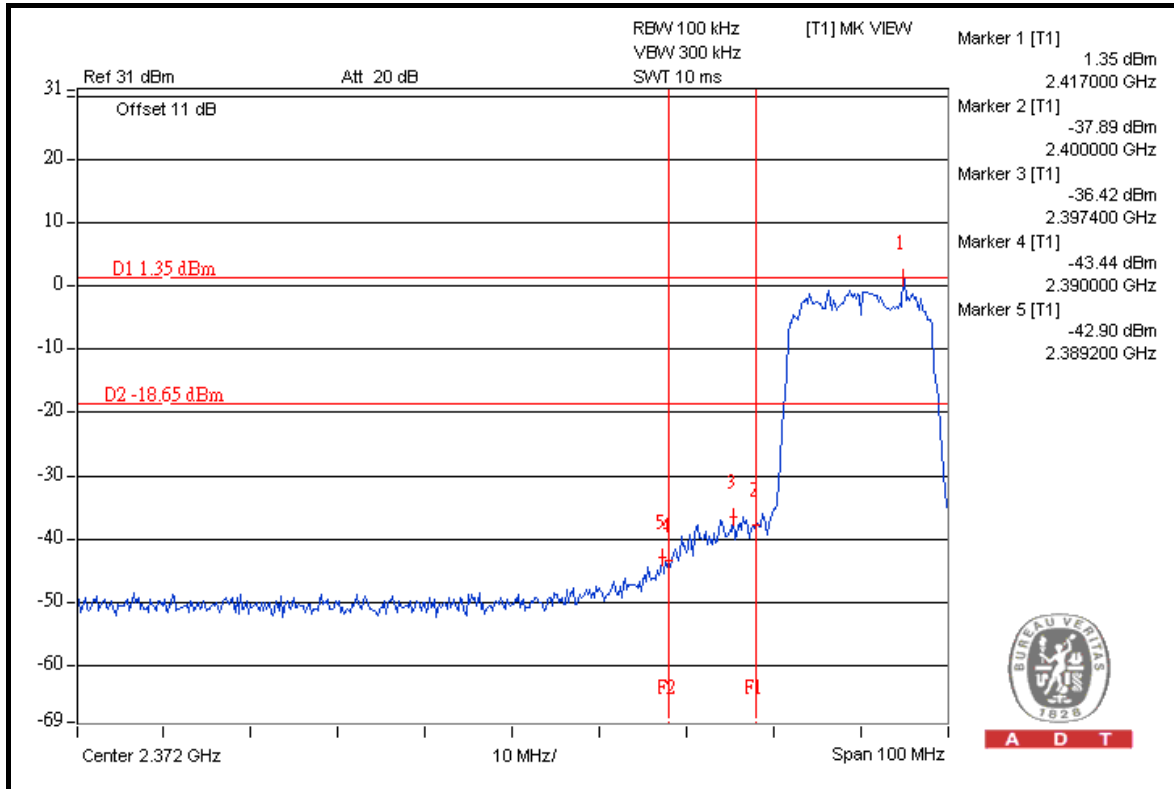



A D T

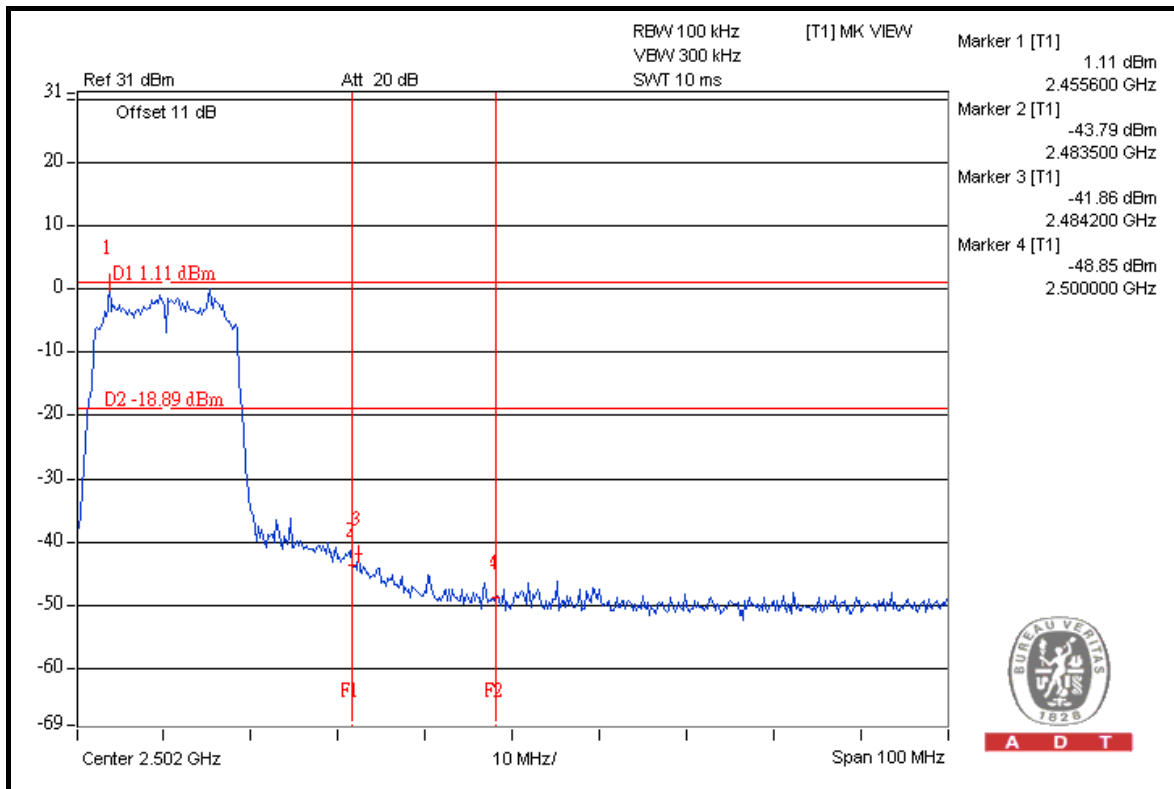
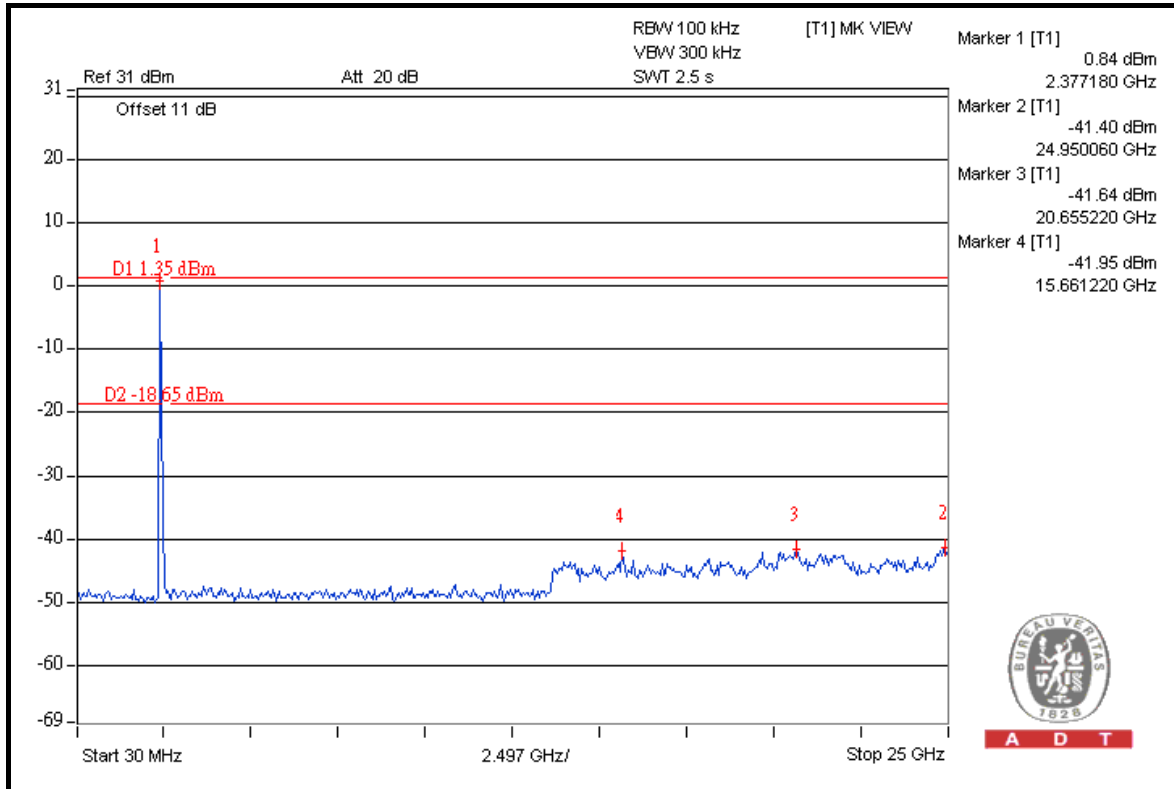



A D T

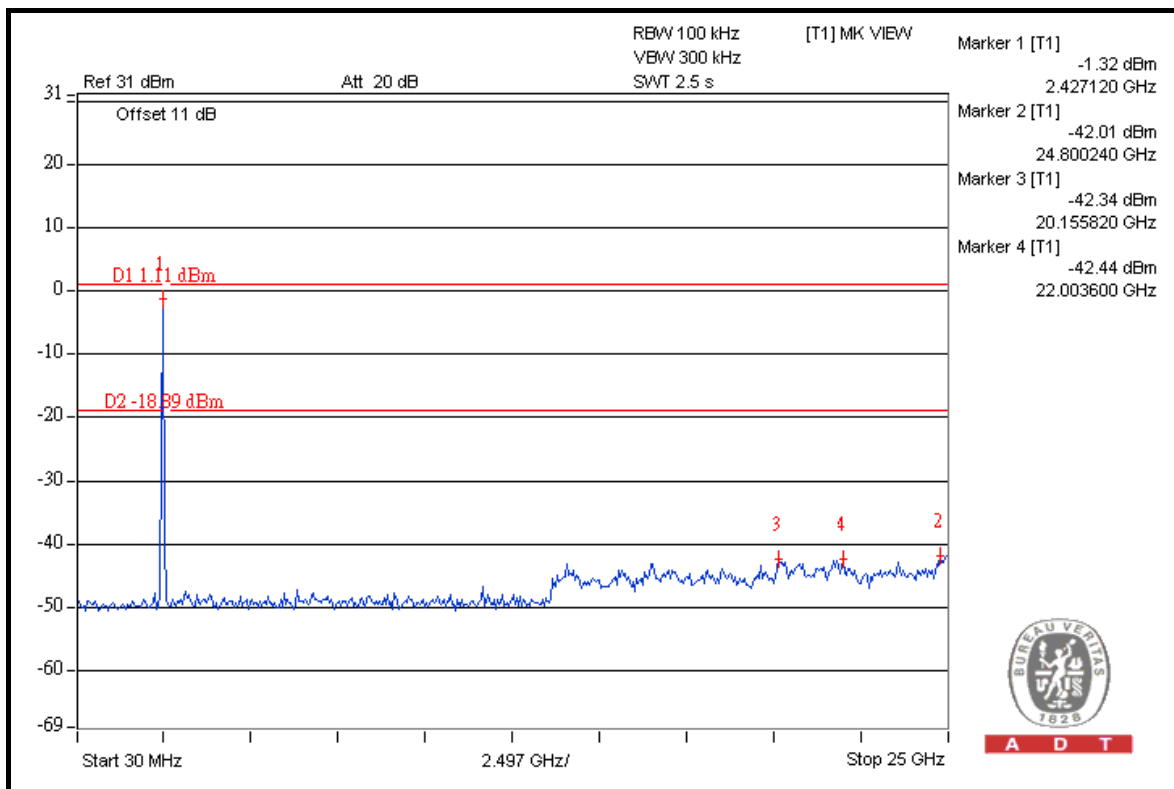
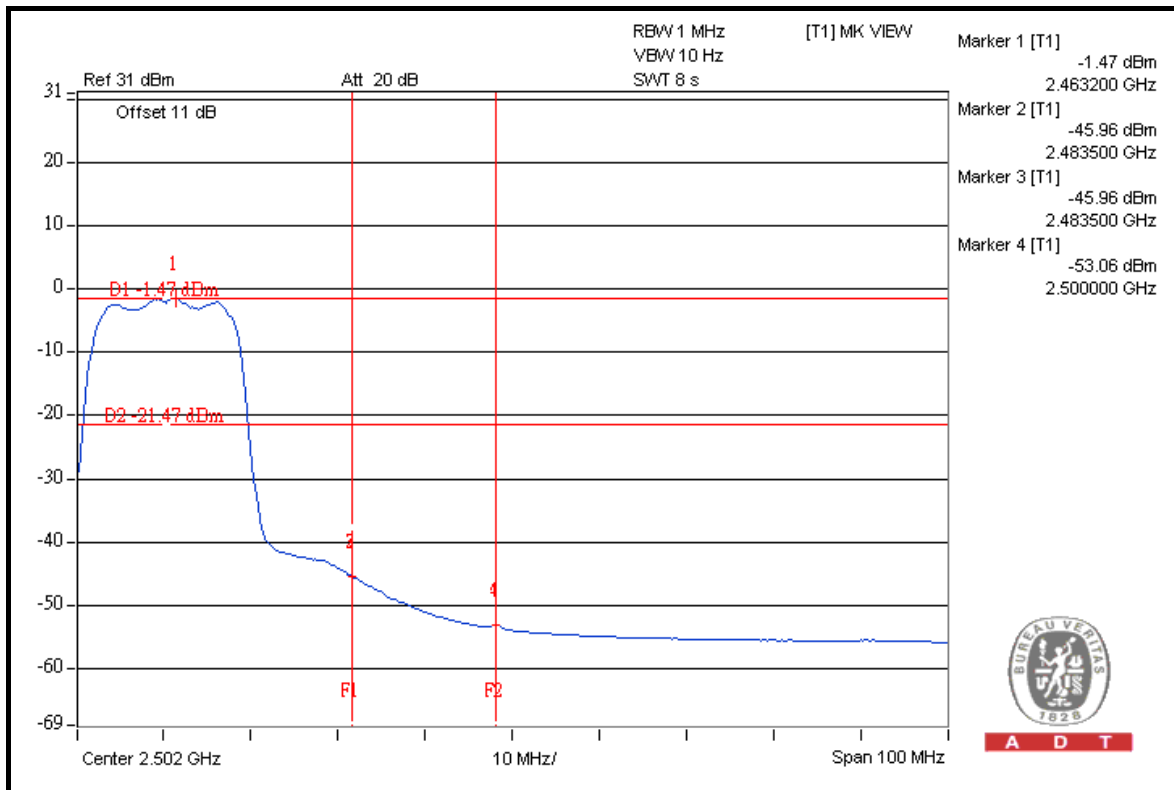



A D T

802.11n (20MHz)

RESTRICT BAND (2310 ~ 2390 MHz)

FREQUENCY (MHz)	FUNDAMENTAL EMISSION (dBuV/m)	DELTA (dB)	MAXIMUM FIELD STRENGTH IN RESTRICT BAND (dBuV/m)	LIMIT (dBuV/m)
2412.00 (PK)	107.6	46.08	61.52	74.00
2412.00 (AV)	94.7	42.98	51.72	54.00

RESTRICT BAND (2483.5 ~ 2500 MHz)

FREQUENCY (MHz)	FUNDAMENTAL EMISSION (dBuV/m)	DELTA (dB)	MAXIMUM FIELD STRENGTH IN RESTRICT BAND (dBuV/m)	LIMIT (dBuV/m)
2462.00 (PK)	106.1	43.67	62.43	74.00
2462.00 (AV)	93.1	43.60	49.50	54.00

NOTE:

1. Delta = Amplitude between the peak of the fundamental and the peak of the band edge emission. Please check following 3 pages.
2. Maximum field strength in restrict band = Fundamental emission – Delta.



A D T

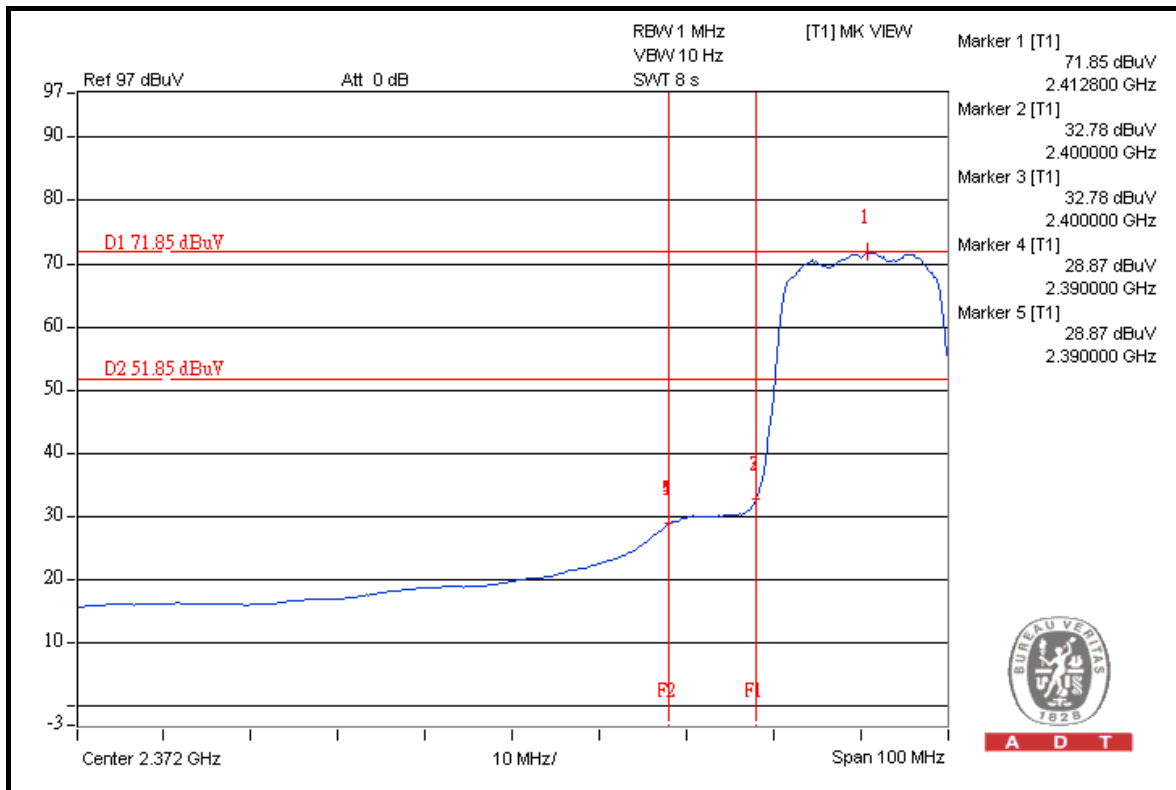
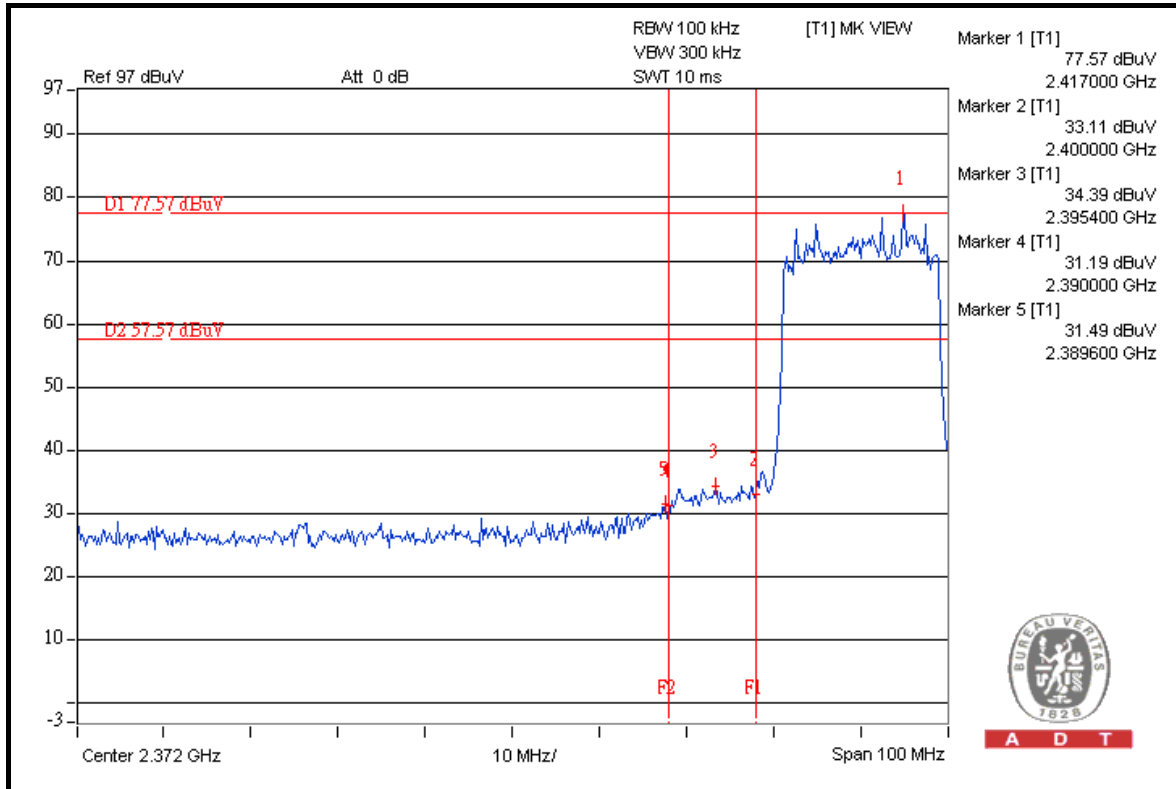



A D T

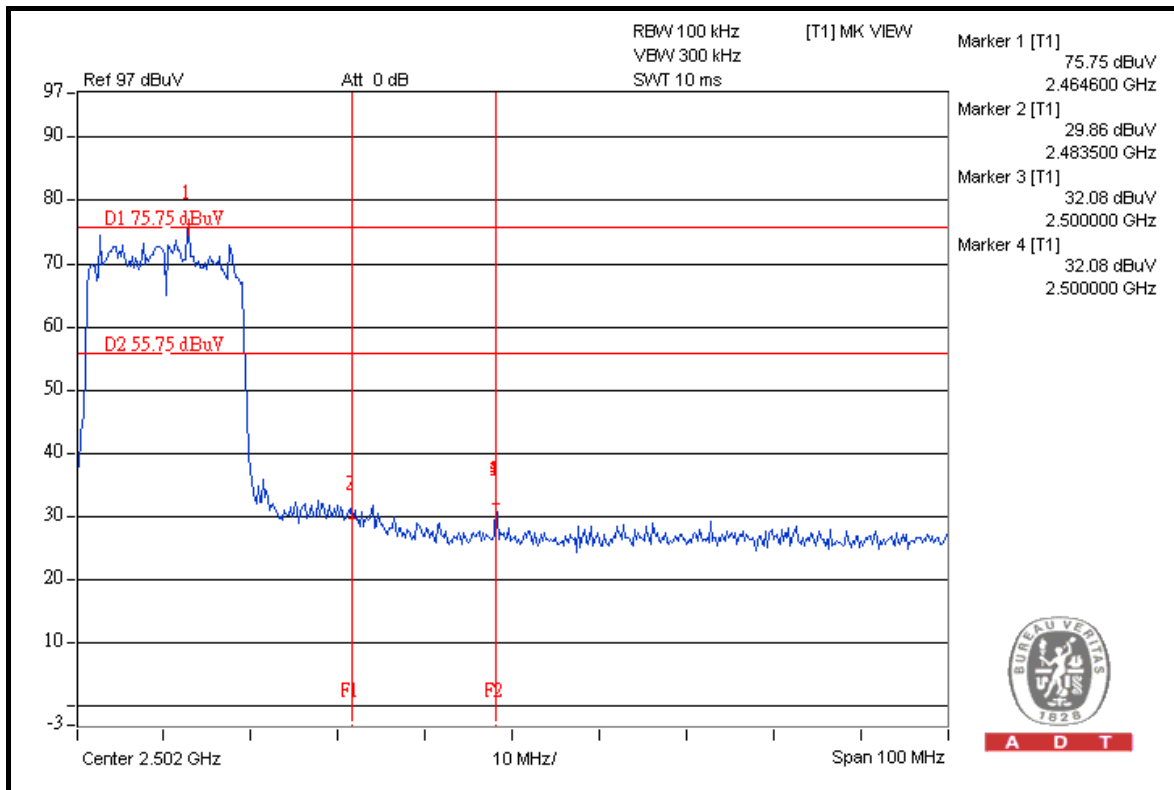
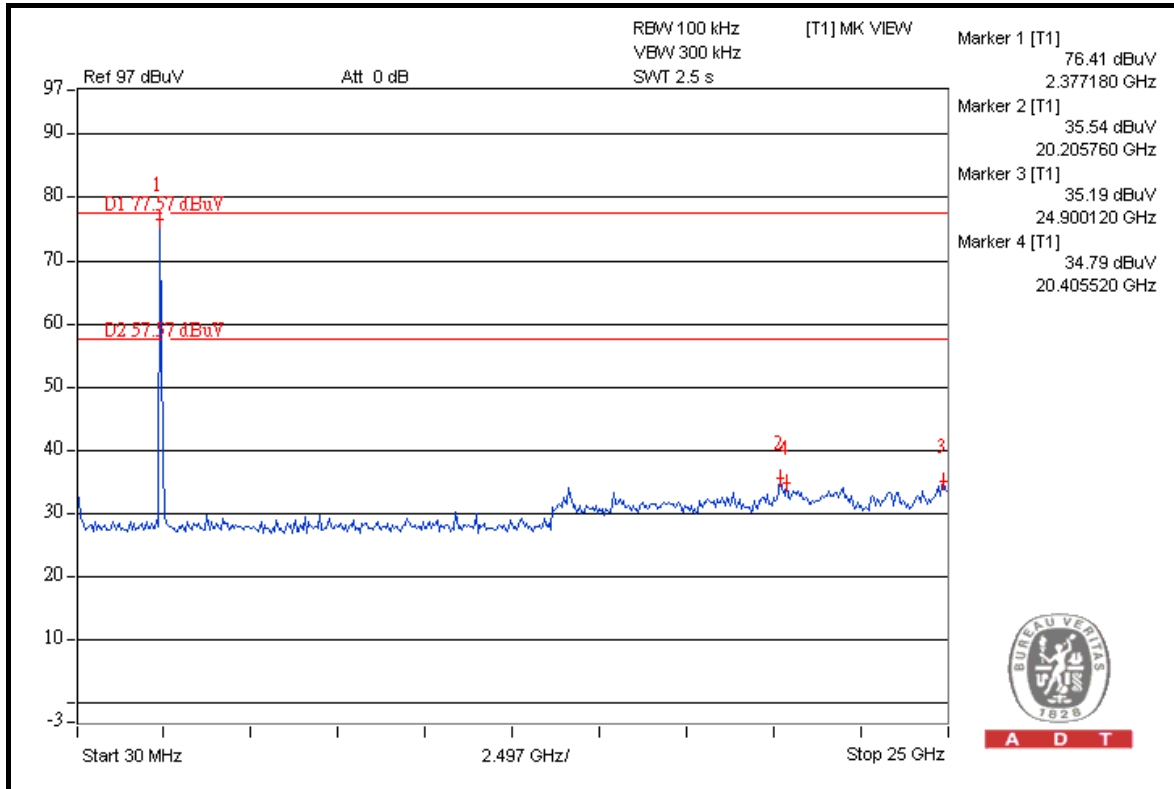



A D T

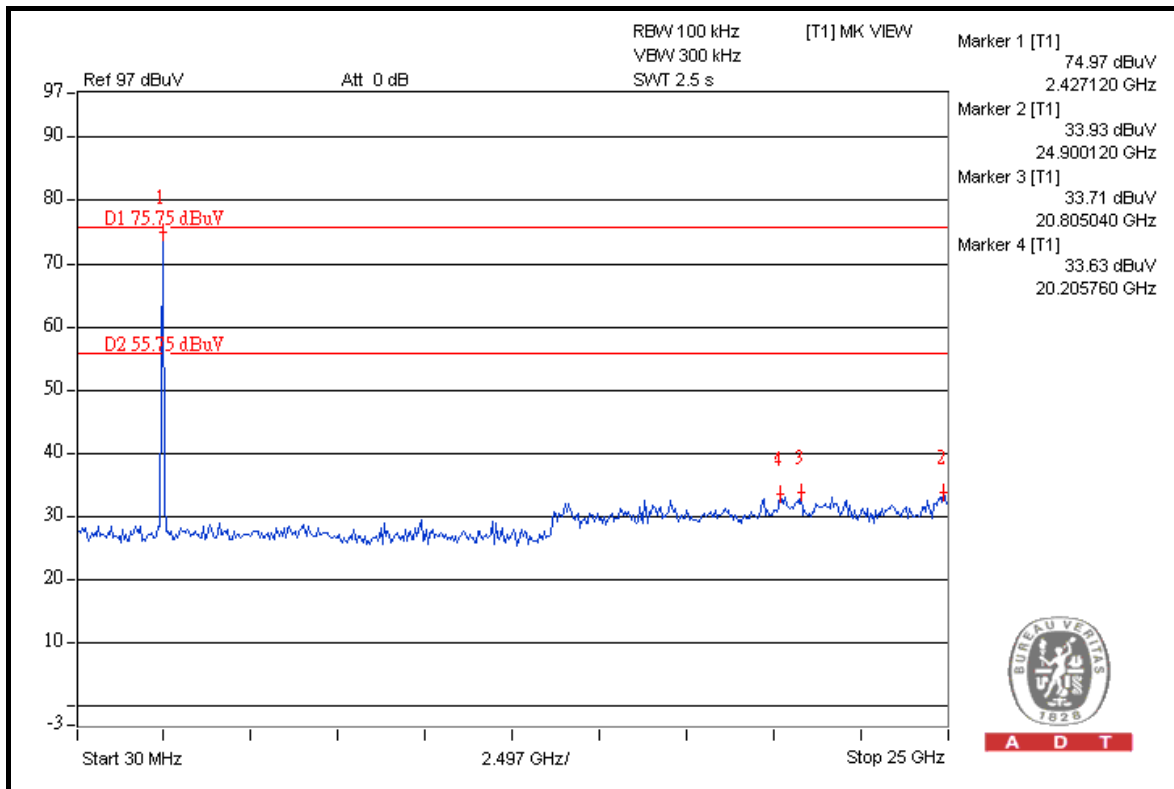
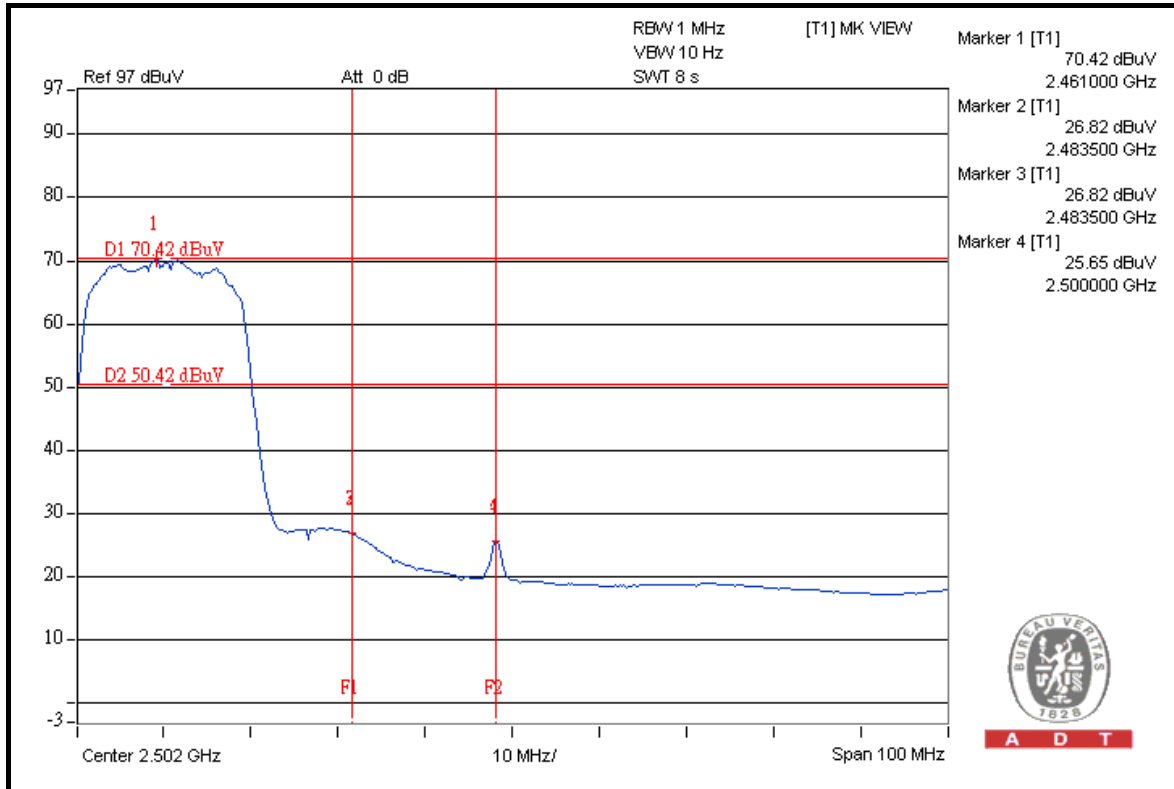



A D T

802.11n (40MHz)

RESTRICT BAND (2310 ~ 2390 MHz)

FREQUENCY (MHz)	FUNDAMENTAL EMISSION (dBuV/m)	DELTA (dB)	MAXIMUM FIELD STRENGTH IN RESTRICT BAND (dBuV/m)	LIMIT (dBuV/m)
2422.00 (PK)	103.8	39.96	63.84	74.00
2422.00 (AV)	87.9	35.40	52.50	54.00

RESTRICT BAND (2483.5 ~ 2500 MHz)

FREQUENCY (MHz)	FUNDAMENTAL EMISSION (dBuV/m)	DELTA (dB)	MAXIMUM FIELD STRENGTH IN RESTRICT BAND (dBuV/m)	LIMIT (dBuV/m)
2452.00 (PK)	103.0	40.55	62.45	74.00
2452.00 (AV)	87.0	40.10	46.90	54.00

NOTE:

1. Delta = Amplitude between the peak of the fundamental and the peak of the band edge emission. Please check following 3 pages.
2. Maximum field strength in restrict band = Fundamental emission – Delta.



A D T

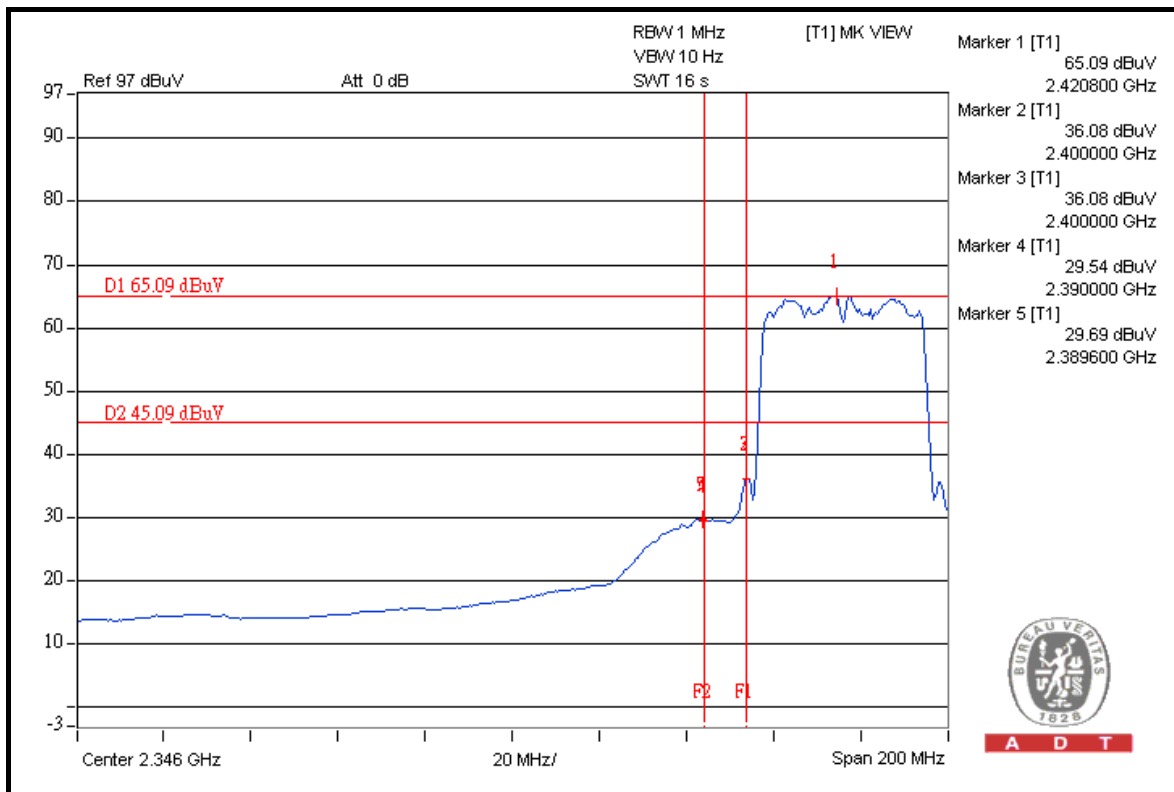
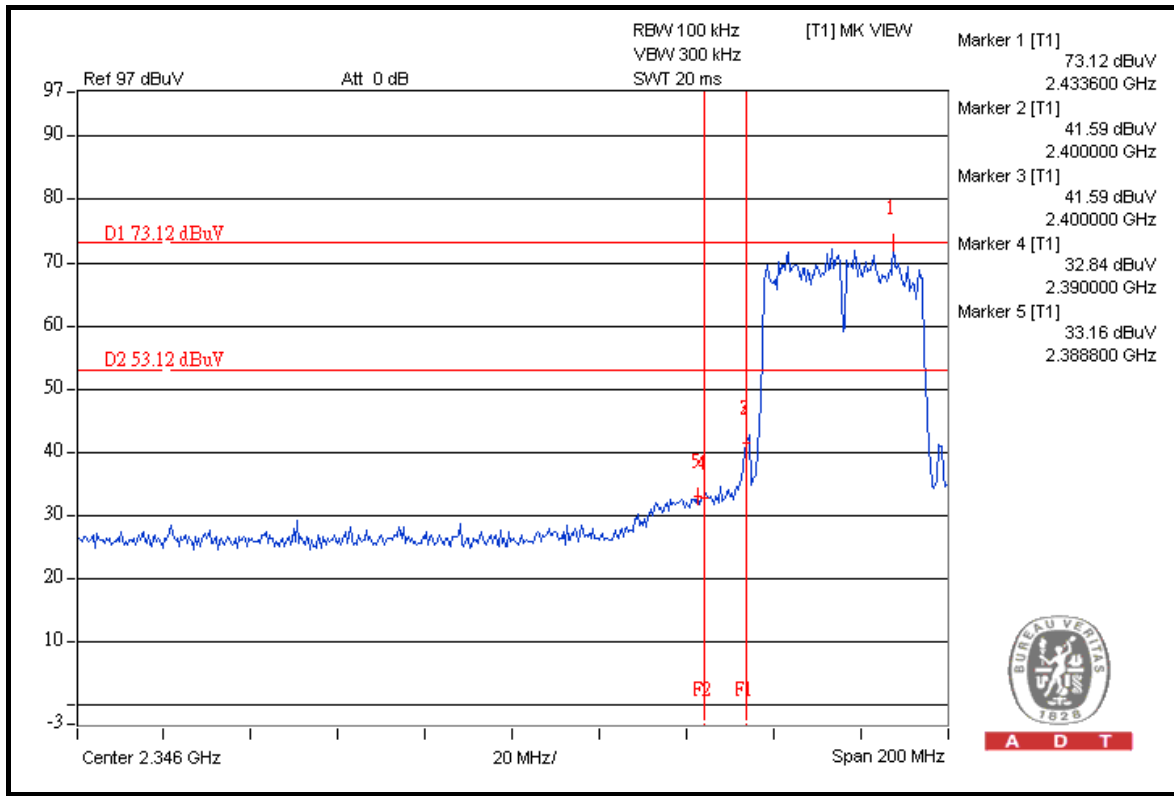



A D T

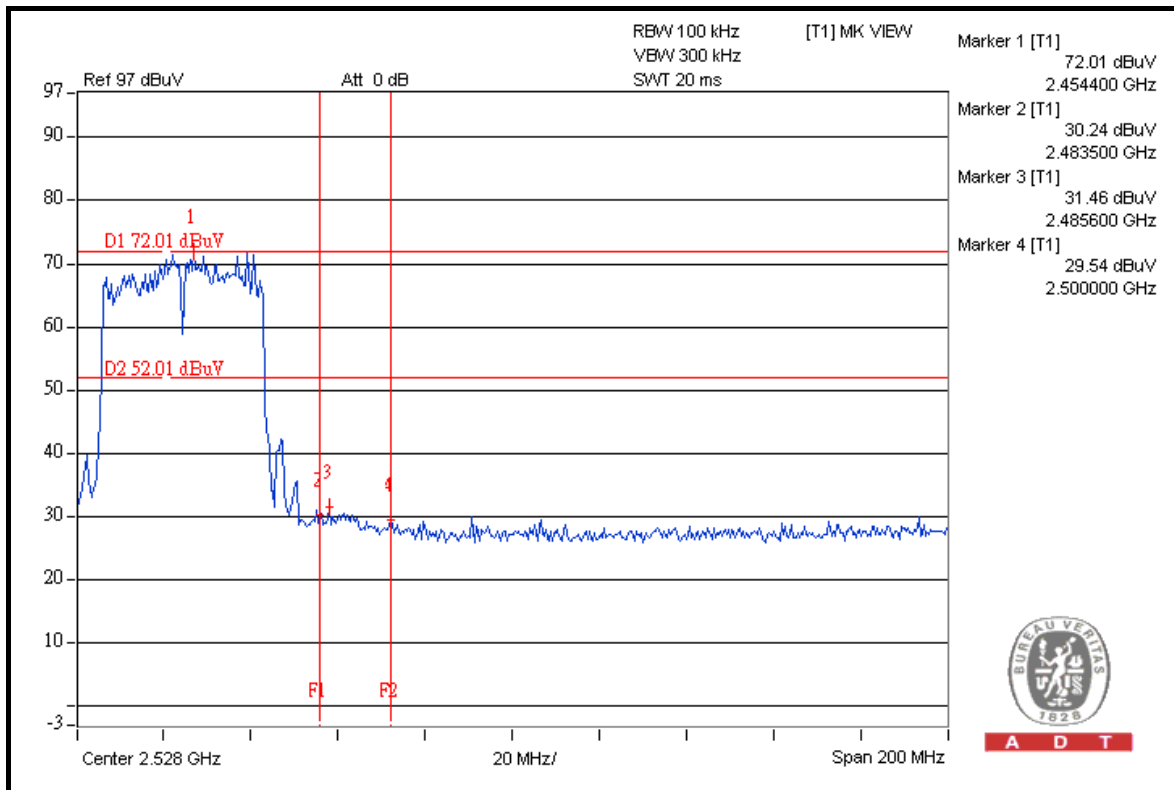
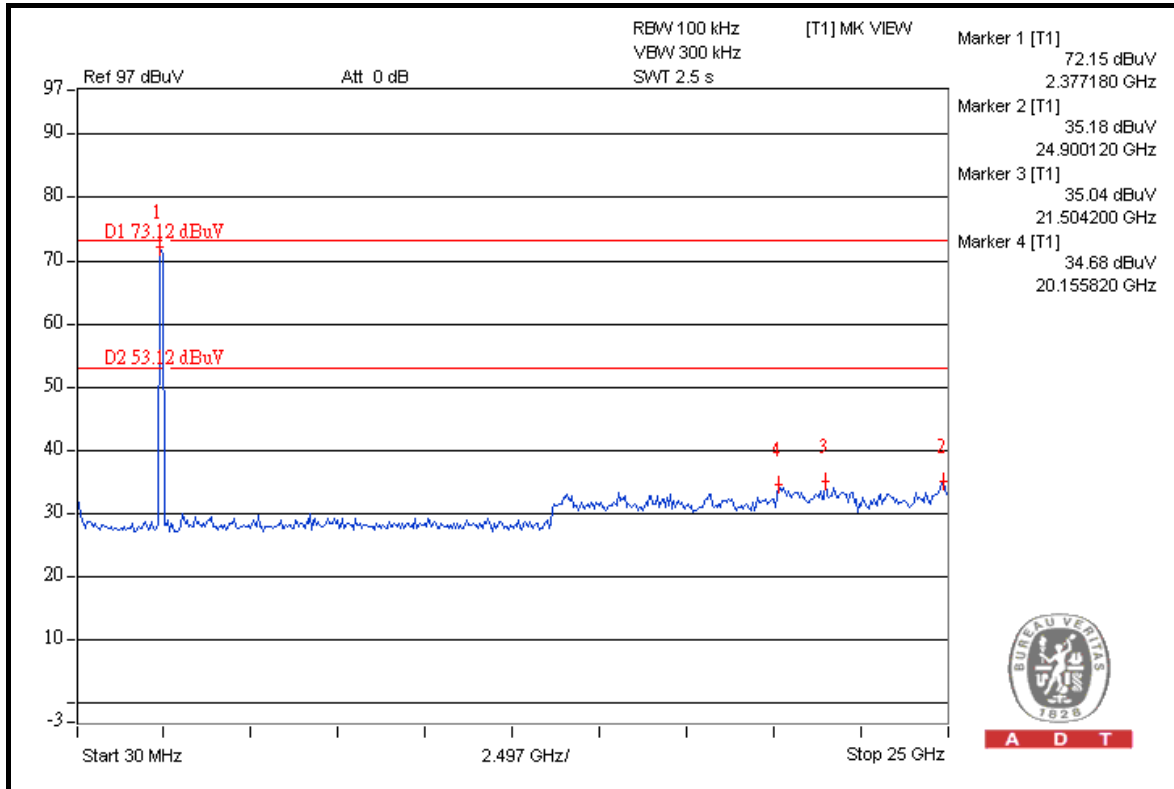



A D T

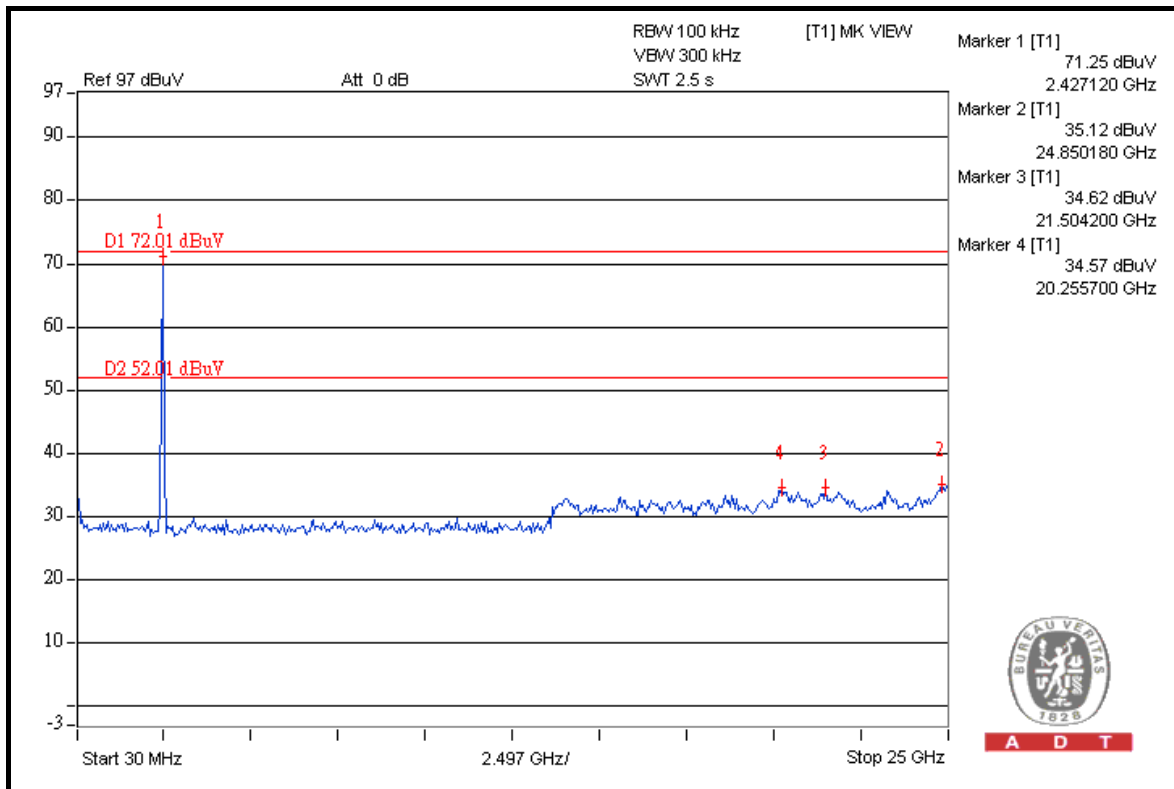
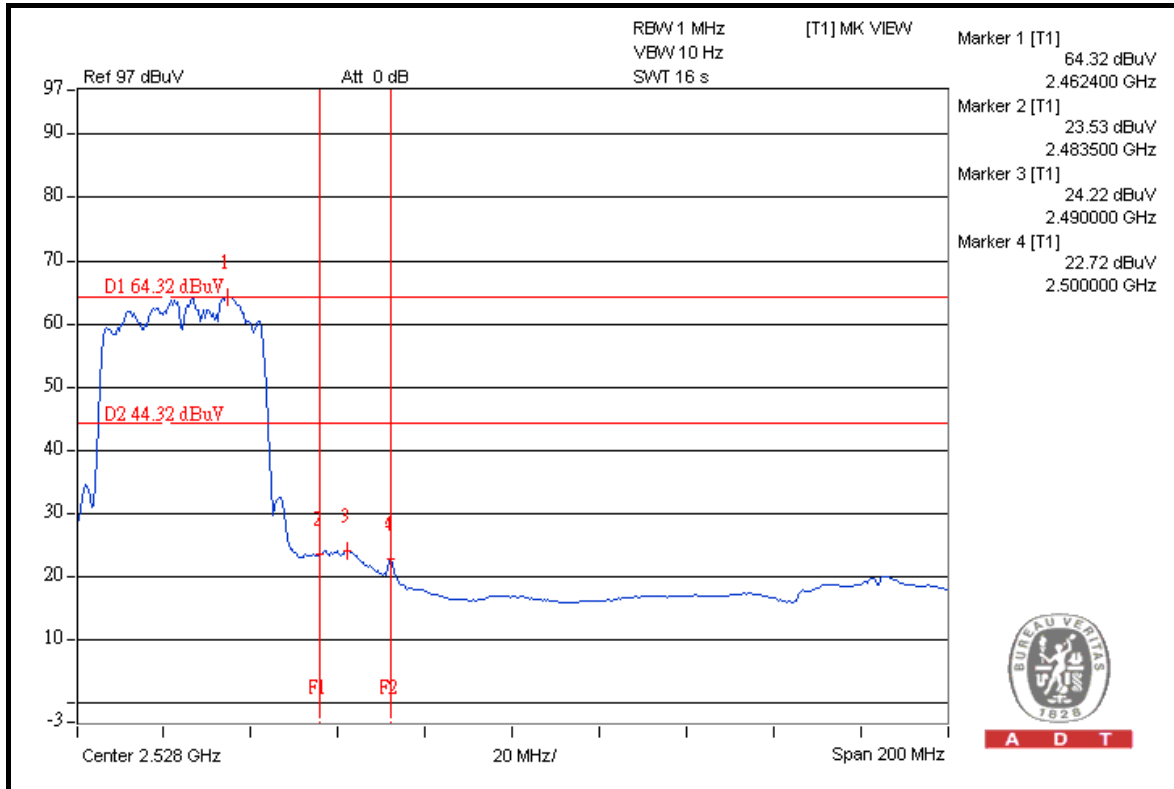



5. TEST TYPES AND RESULTS (FOR 5.0GHz BAND)

5.1 RADIATED EMISSION MEASUREMENT

5.1.1 LIMITS OF RADIATED EMISSION MEASUREMENT

Emissions radiated outside of the specified bands, shall be according to the general radiated limits in 15.209 as following:

FREQUENCIES (MHz)	FIELD STRENGTH (microvolts/meter)	MEASUREMENT DISTANCE (meters)
0.009 ~ 0.490	2400/F(kHz)	300
0.490 ~ 1.705	24000/F(kHz)	30
1.705 ~ 30.0	30	30
30 ~ 88	100	3
88 ~ 216	150	3
216 ~ 960	200	3
Above 960	500	3

NOTE:

1. The lower limit shall apply at the transition frequencies.
2. Emission level (dBuV/m) = 20 log Emission level (uV/m).
3. As shown in 15.35(b), for frequencies above 1000MHz, the field strength limits are based on average detector, however, the peak field strength of any emission shall not exceed the maximum permitted average limits, specified above by more than 20dB under any condition of modulation.



A D T

5.1.2 TEST INSTRUMENTS

DESCRIPTION & MANUFACTURER	MODEL NO.	SERIAL NO.	DATE OF CALIBRATION	DUE DATE OF CALIBRATION
Test Receiver ROHDE & SCHWARZ	ESIB7	100188	Dec. 21, 2009	Dec. 20, 2010
Spectrum Analyzer ROHDE & SCHWARZ	FSP40	100041	Jul. 09, 2010	Jul. 08, 2011
BILOG Antenna SCHWARZBECK	VULB9168	9168-156	Apr. 30, 2010	Apr. 29, 2011
HORN Antenna SCHWARZBECK	BBHA 9120 D	9120D-209	Aug. 02, 2010	Aug. 01, 2011
HORN Antenna SCHWARZBECK	BBHA 9170	BBHA9170242	Dec. 25, 2009	Dec. 24, 2010
Preamplifier Agilent	8447D	2944A10629	Nov. 04, 2009	Nov. 03, 2010
Preamplifier Agilent	8449B	3008A01959	Dec. 10, 2009	Dec. 09, 2010
RF signal cable HUBER+SUHNNER	SUCOFLEX 104	238141/4	May 14, 2010	May 13, 2011
RF signal cable HUBER+SUHNNER	SUCOFLEX 104	12738/6	May 14, 2010	May 13, 2011
Software	ADT_Radiated_ V7.6.15.9.2	NA	NA	NA
Antenna Tower EMCO	2070/2080	512.835.4684	NA	NA
Turn Table EMCO	2087-2.03	NA	NA	NA
Antenna Tower & Turn Table Controller EMCO	2090	NA	NA	NA
26GHz ~ 40GHz Amplifier	EM26400	07026401	Jul. 20, 2010	Jul. 19, 2011

- NOTE:**
1. The calibration interval of the above test instruments is 12 months and the calibrations are traceable to NML/ROC and NIST/USA.
 2. The test was performed in HwaYa Chamber 9.
 3. The horn antenna and HP preamplifier (model: 8449B) are used only for the measurement of emission frequency above 1GHz if tested.
 4. The FCC Site Registration No. is 460141.
 5. The IC Site Registration No. is IC 7450F-4.



A D T

5.1.3 TEST PROCEDURES

- a. The EUT was placed on the top of a rotating table 0.8 meters above the ground at a 3 meters semi-anechoic chamber. The table was rotated 360 degrees to determine the position of the highest radiation.
- b. The EUT was set 3 meters away from the interference-receiving antenna, which was mounted on the top of a variable-height antenna tower.
- c. The antenna is a broadband antenna, and its height is varied from one meter to four meters above the ground to determine the maximum value of the field strength. Both horizontal and vertical polarizations of the antenna are set to make the measurement.
- d. For each suspected emission, the EUT was arranged to its worst case and then the antenna was tuned to heights from 1 meter to 4 meters and the rotatable table was turned from 0 degrees to 360 degrees to find the maximum reading.
- e. The test-receiver system was set to Peak Detect Function and Specified Bandwidth with Maximum Hold Mode.
- f. If the emission level of the EUT in peak mode was lower than the limit specified, then testing could be stopped and the peak values of the EUT would be reported. Otherwise the emissions would be re-tested one by one using peak, quasi-peak or average method as specified and then reported in a data sheet.

NOTE:

1. The resolution bandwidth and video bandwidth of test receiver/spectrum analyzer is 120kHz for Quasi-peak detection at frequency below 1GHz.
2. The resolution bandwidth of test receiver/spectrum analyzer is 100kHz and video bandwidth is 300kHz for Peak detection at frequency above 1GHz.
3. The resolution bandwidth of test receiver/spectrum analyzer is 1MHz and the video bandwidth is 10Hz for Average detection (AV) at frequency above 1GHz.
4. All modes of operation were investigated and the worst-case emissions are reported.

5.1.4 DEVIATION FROM TEST STANDARD

No deviation

5.1.5 TEST SETUP

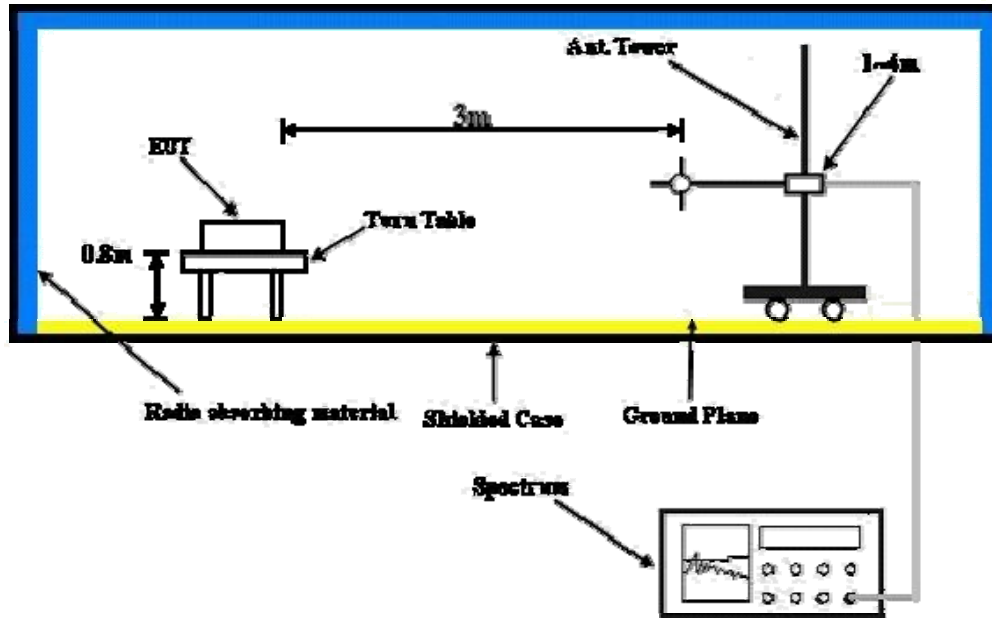

For the actual test configuration, please refer to the attached file (Test Setup Photo).

5.1.6 EUT OPERATING CONDITIONS

Same as 4.1.6



A D T

5.1.7 TEST RESULTS

802.11a (Antenna A)

EUT TEST CONDITION		MEASUREMENT DETAIL	
CHANNEL	Channel 149	FREQUENCY RANGE	1 ~ 40GHz
INPUT POWER (SYSTEM)	120Vac, 60 Hz	DETECTOR FUNCTION	Peak (PK) Average (AV)
ENVIRONMENTAL CONDITIONS	25deg. C, 65%RH 1020 hPa	TESTED BY	Brad Wu

ANTENNA POLARITY & TEST DISTANCE: HORIZONTAL AT 3 M								
NO.	FREQ. (MHz)	EMISSION LEVEL (dBuV/m)	LIMIT (dBuV/m)	MARGIN (dB)	ANTENNA HEIGHT (m)	TABLE ANGLE (Degree)	RAW VALUE (dBuV)	CORRECTION FACTOR (dB/m)
1	#5725.00	85.3 PK	90.0	-4.7	1.00 H	8	45.30	40.00
2	#5725.00	64.8 AV	79.1	-14.3	1.00 H	8	24.80	40.00
3	*5745.00	110.0 PK			1.00 H	8	70.00	40.00
4	*5745.00	99.1 AV			1.00 H	8	59.10	40.00
5	11490.00	59.7 PK	74.0	-14.3	1.06 H	28	9.00	50.70
6	11490.00	46.6 AV	54.0	-7.4	1.06 H	28	-4.10	50.70

ANTENNA POLARITY & TEST DISTANCE: VERTICAL AT 3 M								
NO.	FREQ. (MHz)	EMISSION LEVEL (dBuV/m)	LIMIT (dBuV/m)	MARGIN (dB)	ANTENNA HEIGHT (m)	TABLE ANGLE (Degree)	RAW VALUE (dBuV)	CORRECTION FACTOR (dB/m)
1	#5725.00	82.1 PK	87.0	-4.9	1.04 V	10	42.10	40.00
2	#5725.00	61.5 AV	76.0	-14.5	1.04 V	10	21.50	40.00
3	*5745.00	107.0 PK			1.04 V	10	67.00	40.00
4	*5745.00	96.0 AV			1.04 V	10	56.00	40.00
5	11490.00	59.3 PK	74.0	-14.7	1.05 V	92	8.60	50.70
6	11490.00	46.2 AV	54.0	-7.8	1.05 V	92	-4.50	50.70

- REMARKS:**
1. Emission level (dBuV/m) = Raw Value (dBuV) + Correction Factor (dB/m).
 2. Correction Factor (dB/m) = Antenna Factor (dB/m) + Cable Factor (dB).
 3. The other emission levels were very low against the limit.
 4. Margin value = Emission level – Limit value.
 5. “ * “: Fundamental frequency.
 6. The limit value is defined as per 15.247.
 7. "#":The radiated frequency is out the restricted band.



A D T

EUT TEST CONDITION		MEASUREMENT DETAIL	
CHANNEL	Channel 157	FREQUENCY RANGE	1 ~ 40GHz
INPUT POWER (SYSTEM)	120Vac, 60 Hz	DETECTOR FUNCTION	Peak (PK) Average (AV)
ENVIRONMENTAL CONDITIONS	25deg. C, 65%RH 1020 hPa	TESTED BY	Brad Wu

ANTENNA POLARITY & TEST DISTANCE: HORIZONTAL AT 3 M								
NO.	FREQ. (MHz)	EMISSION LEVEL (dBuV/m)	LIMIT (dBuV/m)	MARGIN (dB)	ANTENNA HEIGHT (m)	TABLE ANGLE (Degree)	RAW VALUE (dBuV)	CORRECTION FACTOR (dB/m)
1	*5785.00	109.8 PK			1.01 H	9	69.80	40.00
2	*5785.00	98.9 AV			1.01 H	9	58.90	40.00
3	11570.00	60.0 PK	74.0	-14.0	1.05 H	231	9.50	50.50
4	11570.00	46.9 AV	54.0	-7.1	1.05 H	231	-3.60	50.50
ANTENNA POLARITY & TEST DISTANCE: VERTICAL AT 3 M								
NO.	FREQ. (MHz)	EMISSION LEVEL (dBuV/m)	LIMIT (dBuV/m)	MARGIN (dB)	ANTENNA HEIGHT (m)	TABLE ANGLE (Degree)	RAW VALUE (dBuV)	CORRECTION FACTOR (dB/m)
1	*5785.00	106.8 PK			1.05 V	11	66.80	40.00
2	*5785.00	95.8 AV			1.05 V	11	55.80	40.00
3	11570.00	59.5 PK	74.0	-14.5	1.03 V	21	9.00	50.50
4	11570.00	46.4 AV	54.0	-7.6	1.03 V	21	-4.10	50.50

- REMARKS:**
1. Emission level (dBuV/m) = Raw Value (dBuV) + Correction Factor (dB/m).
 2. Correction Factor (dB/m) = Antenna Factor (dB/m) + Cable Factor (dB).
 3. The other emission levels were very low against the limit.
 4. Margin value = Emission level – Limit value.
 5. “ * ”: Fundamental frequency.
 6. The limit value is defined as per 15.247.



A D T

EUT TEST CONDITION		MEASUREMENT DETAIL	
CHANNEL	Channel 165	FREQUENCY RANGE	1 ~ 40GHz
INPUT POWER (SYSTEM)	120Vac, 60 Hz	DETECTOR FUNCTION	Peak (PK) Average (AV)
ENVIRONMENTAL CONDITIONS	25deg. C, 65%RH 1020 hPa	TESTED BY	Brad Wu

ANTENNA POLARITY & TEST DISTANCE: HORIZONTAL AT 3 M								
NO.	FREQ. (MHz)	EMISSION LEVEL (dBuV/m)	LIMIT (dBuV/m)	MARGIN (dB)	ANTENNA HEIGHT (m)	TABLE ANGLE (Degree)	RAW VALUE (dBuV)	CORRECTION FACTOR (dB/m)
1	*5825.00	110.3 PK			1.00 H	6	70.20	40.10
2	*5825.00	99.2 AV			1.00 H	6	59.10	40.10
3	#5850.00	80.9 PK	90.3	-9.4	1.00 H	6	40.80	40.10
4	#5850.00	59.7 AV	79.2	-19.5	1.00 H	6	19.60	40.10
5	11650.00	60.4 PK	74.0	-13.6	1.05 H	68	10.00	50.40
6	11650.00	47.2 AV	54.0	-6.8	1.05 H	68	-3.20	50.40

ANTENNA POLARITY & TEST DISTANCE: VERTICAL AT 3 M								
NO.	FREQ. (MHz)	EMISSION LEVEL (dBuV/m)	LIMIT (dBuV/m)	MARGIN (dB)	ANTENNA HEIGHT (m)	TABLE ANGLE (Degree)	RAW VALUE (dBuV)	CORRECTION FACTOR (dB/m)
1	*5825.00	107.2 PK			1.05 V	11	67.10	40.10
2	*5825.00	96.2 AV			1.05 V	11	56.10	40.10
3	#5850.00	77.8 PK	87.2	-9.4	1.05 V	11	37.70	40.10
4	#5850.00	56.7 AV	76.2	-19.5	1.05 V	11	16.60	40.10
5	11650.00	60.1 PK	74.0	-13.9	1.03 V	26	9.70	50.40
6	11650.00	47.0 AV	54.0	-7.0	1.03 V	26	-3.40	50.40

- REMARKS:**
1. Emission level (dBuV/m) = Raw Value (dBuV) + Correction Factor (dB/m).
 2. Correction Factor (dB/m) = Antenna Factor (dB/m) + Cable Factor (dB).
 3. The other emission levels were very low against the limit.
 4. Margin value = Emission level – Limit value.
 5. “ * “: Fundamental frequency.
 6. The limit value is defined as per 15.247.
 7. "#":The radiated frequency is out the restricted band.



A D T

802.11a (Antenna B)

EUT TEST CONDITION		MEASUREMENT DETAIL	
CHANNEL	Channel 149	FREQUENCY RANGE	1 ~ 40GHz
INPUT POWER (SYSTEM)	120Vac, 60 Hz	DETECTOR FUNCTION	Peak (PK) Average (AV)
ENVIRONMENTAL CONDITIONS	25deg. C, 65%RH 1020 hPa	TESTED BY	Brad Wu

ANTENNA POLARITY & TEST DISTANCE: HORIZONTAL AT 3 M								
NO.	FREQ. (MHz)	EMISSION LEVEL (dBuV/m)	LIMIT (dBuV/m)	MARGIN (dB)	ANTENNA HEIGHT (m)	TABLE ANGLE (Degree)	RAW VALUE (dBuV)	CORRECTION FACTOR (dB/m)
1	#5725.00	76.6 PK	84.8	-8.2	1.00 H	62	36.60	40.00
2	#5725.00	59.8 AV	73.8	-14.0	1.00 H	62	19.80	40.00
3	*5745.00	104.8 PK			1.00 H	62	64.80	40.00
4	*5745.00	93.8 AV			1.00 H	62	53.80	40.00
5	11490.00	55.0 PK	74.0	-19.0	1.06 H	220	4.30	50.70
6	11490.00	43.8 AV	54.0	-10.2	1.06 H	220	-6.90	50.70

ANTENNA POLARITY & TEST DISTANCE: VERTICAL AT 3 M								
NO.	FREQ. (MHz)	EMISSION LEVEL (dBuV/m)	LIMIT (dBuV/m)	MARGIN (dB)	ANTENNA HEIGHT (m)	TABLE ANGLE (Degree)	RAW VALUE (dBuV)	CORRECTION FACTOR (dB/m)
1	#5725.00	79.8 PK	87.6	-7.8	1.11 V	300	39.80	40.00
2	#5725.00	62.8 AV	76.8	-14.0	1.11 V	300	22.80	40.00
3	*5745.00	107.6 PK			1.11 V	300	67.60	40.00
4	*5745.00	96.8 AV			1.11 V	300	56.80	40.00
5	11490.00	55.3 PK	74.0	-18.7	1.05 V	216	4.60	50.70
6	11490.00	44.0 AV	54.0	-10.0	1.05 V	216	-6.70	50.70

- REMARKS:**
1. Emission level (dBuV/m) = Raw Value (dBuV) + Correction Factor (dB/m).
 2. Correction Factor (dB/m) = Antenna Factor (dB/m) + Cable Factor (dB).
 3. The other emission levels were very low against the limit.
 4. Margin value = Emission level – Limit value.
 5. “ * “: Fundamental frequency.
 6. The limit value is defined as per 15.247.
 7. “#”:The radiated frequency is out the restricted band.



A D T

EUT TEST CONDITION		MEASUREMENT DETAIL	
CHANNEL	Channel 157	FREQUENCY RANGE	1 ~ 40GHz
INPUT POWER (SYSTEM)	120Vac, 60 Hz	DETECTOR FUNCTION	Peak (PK) Average (AV)
ENVIRONMENTAL CONDITIONS	25deg. C, 65%RH 1020 hPa	TESTED BY	Brad Wu

ANTENNA POLARITY & TEST DISTANCE: HORIZONTAL AT 3 M								
NO.	FREQ. (MHz)	EMISSION LEVEL (dBuV/m)	LIMIT (dBuV/m)	MARGIN (dB)	ANTENNA HEIGHT (m)	TABLE ANGLE (Degree)	RAW VALUE (dBuV)	CORRECTION FACTOR (dB/m)
1	*5785.00	104.5 PK			1.02 H	65	64.50	40.00
2	*5785.00	93.5 AV			1.02 H	65	53.50	40.00
3	11570.00	56.4 PK	74.0	-17.6	1.08 H	235	5.90	50.50
4	11570.00	44.8 AV	54.0	-9.2	1.08 H	235	-5.70	50.50
ANTENNA POLARITY & TEST DISTANCE: VERTICAL AT 3 M								
NO.	FREQ. (MHz)	EMISSION LEVEL (dBuV/m)	LIMIT (dBuV/m)	MARGIN (dB)	ANTENNA HEIGHT (m)	TABLE ANGLE (Degree)	RAW VALUE (dBuV)	CORRECTION FACTOR (dB/m)
1	*5785.00	107.4 PK			1.10 V	302	67.40	40.00
2	*5785.00	96.6 AV			1.10 V	302	56.60	40.00
3	11570.00	56.8 PK	74.0	-17.2	1.05 V	213	6.30	50.50
4	11570.00	45.1 AV	54.0	-8.9	1.05 V	213	-5.40	50.50

- REMARKS:**
1. Emission level (dBuV/m) = Raw Value (dBuV) + Correction Factor (dB/m).
 2. Correction Factor (dB/m) = Antenna Factor (dB/m) + Cable Factor (dB).
 3. The other emission levels were very low against the limit.
 4. Margin value = Emission level – Limit value.
 5. “ * ”: Fundamental frequency.
 6. The limit value is defined as per 15.247.



A D T

EUT TEST CONDITION		MEASUREMENT DETAIL	
CHANNEL	Channel 165	FREQUENCY RANGE	1 ~ 40GHz
INPUT POWER (SYSTEM)	120Vac, 60 Hz	DETECTOR FUNCTION	Peak (PK) Average (AV)
ENVIRONMENTAL CONDITIONS	25deg. C, 65%RH 1020 hPa	TESTED BY	Brad Wu

ANTENNA POLARITY & TEST DISTANCE: HORIZONTAL AT 3 M								
NO.	FREQ. (MHz)	EMISSION LEVEL (dBuV/m)	LIMIT (dBuV/m)	MARGIN (dB)	ANTENNA HEIGHT (m)	TABLE ANGLE (Degree)	RAW VALUE (dBuV)	CORRECTION FACTOR (dB/m)
1	*5825.00	103.8 PK			1.03 H	64	63.70	40.10
2	*5825.00	92.8 AV			1.03 H	64	52.70	40.10
3	#5850.00	66.4 PK	83.8	-17.4	1.03 H	64	26.30	40.10
4	#5850.00	54.2 AV	72.8	-18.6	1.03 H	64	14.10	40.10
5	11650.00	57.1 PK	74.0	-16.9	1.05 H	26	6.70	50.40
6	11650.00	45.0 AV	54.0	-9.0	1.05 H	26	-5.40	50.40
ANTENNA POLARITY & TEST DISTANCE: VERTICAL AT 3 M								
NO.	FREQ. (MHz)	EMISSION LEVEL (dBuV/m)	LIMIT (dBuV/m)	MARGIN (dB)	ANTENNA HEIGHT (m)	TABLE ANGLE (Degree)	RAW VALUE (dBuV)	CORRECTION FACTOR (dB/m)
1	*5825.00	106.8 PK			1.10 V	289	66.70	40.10
2	*5825.00	96.0 AV			1.10 V	289	55.90	40.10
3	#5850.00	69.6 PK	86.8	-17.2	1.10 V	289	29.50	40.10
4	#5850.00	57.5 AV	76.0	-18.5	1.10 V	289	17.40	40.10
5	11650.00	57.4 PK	74.0	-16.6	1.03 V	224	7.00	50.40
6	11650.00	45.4 AV	54.0	-8.6	1.03 V	224	-5.00	50.40

- REMARKS:**
1. Emission level (dBuV/m) = Raw Value (dBuV) + Correction Factor (dB/m).
 2. Correction Factor (dB/m) = Antenna Factor (dB/m) + Cable Factor (dB).
 3. The other emission levels were very low against the limit.
 4. Margin value = Emission level – Limit value.
 5. “ * “: Fundamental frequency.
 6. The limit value is defined as per 15.247.
 7. "#":The radiated frequency is out the restricted band.



A D T

802.11n (20MHz)

EUT TEST CONDITION		MEASUREMENT DETAIL	
CHANNEL	Channel 149	FREQUENCY RANGE	1 ~ 40GHz
INPUT POWER (SYSTEM)	120Vac, 60 Hz	DETECTOR FUNCTION	Peak (PK) Average (AV)
ENVIRONMENTAL CONDITIONS	25deg. C, 65%RH 1020 hPa	TESTED BY	Sun Lin

ANTENNA POLARITY & TEST DISTANCE: HORIZONTAL AT 3 M								
NO.	FREQ. (MHz)	EMISSION LEVEL (dBuV/m)	LIMIT (dBuV/m)	MARGIN (dB)	ANTENNA HEIGHT (m)	TABLE ANGLE (Degree)	RAW VALUE (dBuV)	CORRECTION FACTOR (dB/m)
1	2500.00	56.8 PK	74.0	-17.2	1.45 H	263	24.10	32.70
2	2500.00	46.3 AV	54.0	-7.7	1.45 H	263	13.60	32.70
3	5000.00	55.6 PK	74.0	-18.4	1.08 H	122	16.80	38.80
4	5000.00	48.7 AV	54.0	-5.3	1.08 H	122	9.90	38.80
5	#5725.00	85.7 PK	91.0	-5.3	1.00 H	343	45.70	40.00
6	#5725.00	67.5 AV	78.5	-11.0	1.00 H	343	27.50	40.00
7	*5745.00	111.0 PK			1.02 H	343	71.00	40.00
8	*5745.00	98.5 AV			1.02 H	343	58.50	40.00
9	11490.00	60.5 PK	74.0	-13.5	1.41 H	188	9.80	50.70
10	11490.00	46.6 AV	54.0	-7.4	1.41 H	188	-4.10	50.70

ANTENNA POLARITY & TEST DISTANCE: VERTICAL AT 3 M								
NO.	FREQ. (MHz)	EMISSION LEVEL (dBuV/m)	LIMIT (dBuV/m)	MARGIN (dB)	ANTENNA HEIGHT (m)	TABLE ANGLE (Degree)	RAW VALUE (dBuV)	CORRECTION FACTOR (dB/m)
1	2500.00	58.9 PK	74.0	-15.1	1.03 V	69	26.20	32.70
2	2500.00	52.7 AV	54.0	-1.3	1.03 V	69	20.00	32.70
3	5000.00	50.7 PK	74.0	-23.3	1.63 V	263	11.90	38.80
4	5000.00	44.8 AV	54.0	-9.2	1.63 V	263	6.00	38.80
5	#5725.00	82.2 PK	89.1	-6.9	1.02 V	15	42.20	40.00
6	#5725.00	65.3 AV	76.2	-10.9	1.02 V	15	25.30	40.00
7	*5745.00	109.1 PK			1.00 V	12	69.10	40.00
8	*5745.00	96.2 AV			1.00 V	12	56.20	40.00
9	11490.00	57.5 PK	74.0	-16.5	1.24 V	45	6.80	50.70
10	11490.00	44.9 AV	54.0	-9.1	1.24 V	45	-5.80	50.70

- REMARKS:**
1. Emission level (dBuV/m) = Raw Value (dBuV) + Correction Factor (dB/m).
 2. Correction Factor (dB/m) = Antenna Factor (dB/m) + Cable Factor (dB).
 3. The other emission levels were very low against the limit.
 4. Margin value = Emission level – Limit value.
 5. “ * “: Fundamental frequency.
 6. The limit value is defined as per 15.247.
 7. "#":The radiated frequency is out the restricted band.



A D T

EUT TEST CONDITION		MEASUREMENT DETAIL	
CHANNEL	Channel 157	FREQUENCY RANGE	1 ~ 40GHz
INPUT POWER (SYSTEM)	120Vac, 60 Hz	DETECTOR FUNCTION	Peak (PK) Average (AV)
ENVIRONMENTAL CONDITIONS	25deg. C, 65%RH 1020 hPa	TESTED BY	Sun Lin

ANTENNA POLARITY & TEST DISTANCE: HORIZONTAL AT 3 M								
NO.	FREQ. (MHz)	EMISSION LEVEL (dBuV/m)	LIMIT (dBuV/m)	MARGIN (dB)	ANTENNA HEIGHT (m)	TABLE ANGLE (Degree)	RAW VALUE (dBuV)	CORRECTION FACTOR (dB/m)
1	2500.00	56.9 PK	74.0	-17.1	1.32 H	211	24.20	32.70
2	2500.00	46.7 AV	54.0	-7.3	1.32 H	211	14.00	32.70
3	5000.00	55.3 PK	74.0	-18.7	1.02 H	135	16.50	38.80
4	5000.00	48.8 AV	54.0	-5.2	1.02 H	135	10.00	38.80
5	*5785.00	110.8 PK			1.05 H	325	70.80	40.00
6	*5785.00	98.3 AV			1.05 H	325	58.30	40.00
7	11570.00	60.7 PK	74.0	-13.3	1.35 H	169	10.20	50.50
8	11570.00	46.3 AV	54.0	-7.7	1.35 H	169	-4.20	50.50
ANTENNA POLARITY & TEST DISTANCE: VERTICAL AT 3 M								
NO.	FREQ. (MHz)	EMISSION LEVEL (dBuV/m)	LIMIT (dBuV/m)	MARGIN (dB)	ANTENNA HEIGHT (m)	TABLE ANGLE (Degree)	RAW VALUE (dBuV)	CORRECTION FACTOR (dB/m)
1	2500.00	58.6 PK	74.0	-15.4	1.05 V	70	25.90	32.70
2	2500.00	52.8 AV	54.0	-1.2	1.05 V	70	20.10	32.70
3	5000.00	50.8 PK	74.0	-23.2	1.36 V	251	12.00	38.80
4	5000.00	44.7 AV	54.0	-9.3	1.36 V	251	5.90	38.80
5	*5785.00	108.3 PK			1.06 V	13	68.30	40.00
6	*5785.00	95.3 AV			1.06 V	13	55.30	40.00
7	11570.00	57.8 PK	74.0	-16.2	1.21 V	59	7.30	50.50
8	11570.00	45.0 AV	54.0	-9.0	1.21 V	59	-5.50	50.50

- REMARKS:**
1. Emission level (dBuV/m) = Raw Value (dBuV) + Correction Factor (dB/m).
 2. Correction Factor (dB/m) = Antenna Factor (dB/m) + Cable Factor (dB).
 3. The other emission levels were very low against the limit.
 4. Margin value = Emission level – Limit value.
 5. “ * “: Fundamental frequency.
 6. The limit value is defined as per 15.247.



A D T

EUT TEST CONDITION		MEASUREMENT DETAIL	
CHANNEL	Channel 165	FREQUENCY RANGE	1 ~ 40GHz
INPUT POWER (SYSTEM)	120Vac, 60 Hz	DETECTOR FUNCTION	Peak (PK) Average (AV)
ENVIRONMENTAL CONDITIONS	25deg. C, 65%RH 1020 hPa	TESTED BY	Sun Lin

ANTENNA POLARITY & TEST DISTANCE: HORIZONTAL AT 3 M								
NO.	FREQ. (MHz)	EMISSION LEVEL (dBuV/m)	LIMIT (dBuV/m)	MARGIN (dB)	ANTENNA HEIGHT (m)	TABLE ANGLE (Degree)	RAW VALUE (dBuV)	CORRECTION FACTOR (dB/m)
1	2500.00	56.9 PK	74.0	-17.1	1.32 H	285	24.20	32.70
2	2500.00	46.5 AV	54.0	-7.5	1.32 H	285	13.80	32.70
3	5000.00	55.9 PK	74.0	-18.1	1.07 H	135	17.10	38.80
4	5000.00	48.8 AV	54.0	-5.2	1.07 H	135	10.00	38.80
5	*5825.00	109.3 PK			1.00 H	342	69.20	40.10
6	*5825.00	97.5 AV			1.00 H	342	57.40	40.10
7	#5850.00	72.8 PK	89.3	-16.5	1.00 H	344	32.70	40.10
8	#5850.00	53.0 AV	77.5	-24.5	1.00 H	344	12.90	40.10
9	11650.00	57.9 PK	74.0	-16.1	1.09 H	161	7.50	50.40
10	11650.00	44.9 AV	54.0	-9.1	1.09 H	161	-5.50	50.40
ANTENNA POLARITY & TEST DISTANCE: VERTICAL AT 3 M								
NO.	FREQ. (MHz)	EMISSION LEVEL (dBuV/m)	LIMIT (dBuV/m)	MARGIN (dB)	ANTENNA HEIGHT (m)	TABLE ANGLE (Degree)	RAW VALUE (dBuV)	CORRECTION FACTOR (dB/m)
1	2500.00	58.7 PK	74.0	-15.3	1.09 V	77	26.00	32.70
2	2500.00	52.7 AV	54.0	-1.3	1.09 V	77	20.00	32.70
3	5000.00	50.7 PK	74.0	-23.3	1.25 V	277	11.90	38.80
4	5000.00	44.3 AV	54.0	-9.7	1.25 V	277	5.50	38.80
5	*5825.00	108.5 PK			1.12 V	328	68.40	40.10
6	*5825.00	95.8 AV			1.12 V	328	55.70	40.10
7	#5850.00	70.6 PK	88.5	-17.9	1.11 V	322	30.50	40.10
8	#5850.00	51.8 AV	75.8	-24.0	1.11 V	322	11.70	40.10
9	11650.00	58.2 PK	74.0	-15.8	1.33 V	63	7.80	50.40
10	11650.00	46.0 AV	54.0	-8.0	1.33 V	63	-4.40	50.40

- REMARKS:**
1. Emission level (dBuV/m) = Raw Value (dBuV) + Correction Factor (dB/m).
 2. Correction Factor (dB/m) = Antenna Factor (dB/m) + Cable Factor (dB).
 3. The other emission levels were very low against the limit.
 4. Margin value = Emission level – Limit value.
 5. “ * “: Fundamental frequency.
 6. The limit value is defined as per 15.247.
 7. “#”:The radiated frequency is out the restricted band.



A D T

802.11n (40MHz)

EUT TEST CONDITION		MEASUREMENT DETAIL	
CHANNEL	Channel 151	FREQUENCY RANGE	1 ~ 40GHz
INPUT POWER (SYSTEM)	120Vac, 60 Hz	DETECTOR FUNCTION	Peak (PK) Average (AV)
ENVIRONMENTAL CONDITIONS	25deg. C, 65%RH 1020 hPa	TESTED BY	Sun Lin

ANTENNA POLARITY & TEST DISTANCE: HORIZONTAL AT 3 M								
NO.	FREQ. (MHz)	EMISSION LEVEL (dBuV/m)	LIMIT (dBuV/m)	MARGIN (dB)	ANTENNA HEIGHT (m)	TABLE ANGLE (Degree)	RAW VALUE (dBuV)	CORRECTION FACTOR (dB/m)
1	2500.00	57.0 PK	74.0	-17.0	1.43 H	298	24.30	32.70
2	2500.00	46.3 AV	54.0	-7.7	1.43 H	298	13.60	32.70
3	5000.00	55.6 PK	74.0	-18.4	1.08 H	153	16.80	38.80
4	5000.00	48.7 AV	54.0	-5.3	1.08 H	153	9.90	38.80
5	#5725.00	82.5 PK	87.1	-4.6	1.00 H	340	42.50	40.00
6	#5725.00	63.5 AV	71.5	-8.0	1.00 H	340	23.50	40.00
7	*5755.00	107.1 PK			1.12 H	344	67.10	40.00
8	*5755.00	91.5 AV			1.12 H	344	51.50	40.00
9	11510.00	60.0 PK	74.0	-14.0	1.54 H	186	9.30	50.70
10	11510.00	45.2 AV	54.0	-8.8	1.54 H	186	-5.50	50.70

ANTENNA POLARITY & TEST DISTANCE: VERTICAL AT 3 M								
NO.	FREQ. (MHz)	EMISSION LEVEL (dBuV/m)	LIMIT (dBuV/m)	MARGIN (dB)	ANTENNA HEIGHT (m)	TABLE ANGLE (Degree)	RAW VALUE (dBuV)	CORRECTION FACTOR (dB/m)
1	2500.00	58.6 PK	74.0	-15.4	1.08 V	77	25.90	32.70
2	2500.00	52.9 AV	54.0	-1.1	1.08 V	77	20.20	32.70
3	5000.00	50.9 PK	74.0	-23.1	1.58 V	267	12.10	38.80
4	5000.00	44.7 AV	54.0	-9.3	1.58 V	267	5.90	38.80
5	#5725.00	80.3 PK	86.0	-5.7	1.08 V	98	40.30	40.00
6	#5725.00	62.7 AV	70.3	-7.6	1.08 V	98	22.70	40.00
7	*5755.00	106.0 PK			1.07 V	85	66.00	40.00
8	*5755.00	90.3 AV			1.07 V	85	50.30	40.00
9	11510.00	57.8 PK	74.0	-16.2	1.25 V	82	7.10	50.70
10	11510.00	45.0 AV	54.0	-9.0	1.25 V	82	-5.70	50.70

- REMARKS:**
1. Emission level (dBuV/m) = Raw Value (dBuV) + Correction Factor (dB/m).
 2. Correction Factor (dB/m) = Antenna Factor (dB/m) + Cable Factor (dB).
 3. The other emission levels were very low against the limit.
 4. Margin value = Emission level – Limit value.
 5. “ * “: Fundamental frequency.
 6. The limit value is defined as per 15.247.
 7. "#":The radiated frequency is out the restricted band.



A D T

EUT TEST CONDITION		MEASUREMENT DETAIL	
CHANNEL	Channel 159	FREQUENCY RANGE	1 ~ 40GHz
INPUT POWER (SYSTEM)	120Vac, 60 Hz	DETECTOR FUNCTION	Peak (PK) Average (AV)
ENVIRONMENTAL CONDITIONS	25deg. C, 65%RH 1020 hPa	TESTED BY	Sun Lin

ANTENNA POLARITY & TEST DISTANCE: HORIZONTAL AT 3 M								
NO.	FREQ. (MHz)	EMISSION LEVEL (dBuV/m)	LIMIT (dBuV/m)	MARGIN (dB)	ANTENNA HEIGHT (m)	TABLE ANGLE (Degree)	RAW VALUE (dBuV)	CORRECTION FACTOR (dB/m)
1	2500.00	57.0 PK	74.0	-17.0	1.36 H	252	24.30	32.70
2	2500.00	46.9 AV	54.0	-7.1	1.36 H	252	14.20	32.70
3	5000.00	55.8 PK	74.0	-18.2	1.12 H	132	17.00	38.80
4	5000.00	48.8 AV	54.0	-5.2	1.12 H	132	10.00	38.80
5	*5795.00	106.8 PK			1.00 H	343	66.80	40.00
6	*5795.00	91.3 AV			1.00 H	343	51.30	40.00
7	#5850.00	67.4 PK	86.8	-19.4	1.00 H	338	27.30	40.10
8	#5850.00	47.2 AV	71.3	-24.1	1.00 H	338	7.10	40.10
9	11590.00	58.3 PK	74.0	-15.7	1.46 H	181	7.80	50.50
10	11590.00	45.5 AV	54.0	-8.5	1.46 H	181	-5.00	50.50
ANTENNA POLARITY & TEST DISTANCE: VERTICAL AT 3 M								
NO.	FREQ. (MHz)	EMISSION LEVEL (dBuV/m)	LIMIT (dBuV/m)	MARGIN (dB)	ANTENNA HEIGHT (m)	TABLE ANGLE (Degree)	RAW VALUE (dBuV)	CORRECTION FACTOR (dB/m)
1	2500.00	59.8 PK	74.0	-14.2	1.05 V	72	27.10	32.70
2	2500.00	52.8 AV	54.0	-1.2	1.05 V	72	20.10	32.70
3	5000.00	50.8 PK	74.0	-23.2	1.58 V	265	12.00	38.80
4	5000.00	44.7 AV	54.0	-9.3	1.58 V	265	5.90	38.80
5	*5795.00	105.6 PK			1.08 V	78	65.60	40.00
6	*5795.00	90.0 AV			1.08 V	78	50.00	40.00
7	#5850.00	65.8 PK	85.6	-19.8	1.07 V	89	25.70	40.10
8	#5850.00	45.8 AV	70.0	-24.2	1.07 V	89	5.70	40.10
9	11590.00	57.9 PK	74.0	-16.1	1.28 V	85	7.40	50.50
10	11590.00	46.8 AV	54.0	-7.2	1.28 V	85	-3.70	50.50

- REMARKS:**
1. Emission level (dBuV/m) = Raw Value (dBuV) + Correction Factor (dB/m).
 2. Correction Factor (dB/m) = Antenna Factor (dB/m) + Cable Factor (dB).
 3. The other emission levels were very low against the limit.
 4. Margin value = Emission level – Limit value.
 5. “ * “: Fundamental frequency.
 6. The limit value is defined as per 15.247.
 7. “#”:The radiated frequency is out the restricted band.



A D T

BELOW 1GHz WORST-CASE DATA : 802.11n (20MHz)

EUT TEST CONDITION		MEASUREMENT DETAIL	
CHANNEL	Channel 157	FREQUENCY RANGE	Below 1000MHz
INPUT POWER (SYSTEM)	120Vac, 60 Hz	DETECTOR FUNCTION	Quasi-Peak
ENVIRONMENTAL CONDITIONS	25deg. C, 65%RH 1008 hPa	TESTED BY	Brad Wu

ANTENNA POLARITY & TEST DISTANCE: HORIZONTAL AT 3 M								
NO.	FREQ. (MHz)	EMISSION LEVEL (dBuV/m)	LIMIT (dBuV/m)	MARGIN (dB)	ANTENNA HEIGHT (m)	TABLE ANGLE (Degree)	RAW VALUE (dBuV)	CORRECTION FACTOR (dB/m)
1	99.89	29.9 QP	43.5	-13.6	2.00 H	112	20.50	9.40
2	393.48	36.9 QP	46.0	-9.1	1.00 H	58	20.90	16.00
3	480.97	38.1 QP	46.0	-7.9	1.50 H	88	19.40	18.70
4	667.63	33.6 QP	46.0	-12.4	1.00 H	52	11.10	22.50
5	751.23	37.2 QP	46.0	-8.8	1.00 H	151	13.20	24.00
6	877.61	39.8 QP	46.0	-6.2	1.50 H	247	13.90	25.90
ANTENNA POLARITY & TEST DISTANCE: VERTICAL AT 3 M								
NO.	FREQ. (MHz)	EMISSION LEVEL (dBuV/m)	LIMIT (dBuV/m)	MARGIN (dB)	ANTENNA HEIGHT (m)	TABLE ANGLE (Degree)	RAW VALUE (dBuV)	CORRECTION FACTOR (dB/m)
1	99.89	31.9 QP	43.5	-11.6	1.00 V	88	22.50	9.40
2	393.48	40.6 QP	46.0	-5.4	1.00 V	295	24.60	16.00
3	480.97	41.2 QP	46.0	-4.8	1.00 V	19	22.50	18.70
4	667.63	32.8 QP	46.0	-13.2	1.50 V	286	10.30	22.50
5	751.23	37.5 QP	46.0	-8.5	2.00 V	220	13.50	24.00
6	877.61	37.1 QP	46.0	-8.9	1.50 V	202	11.20	25.90

- REMARKS:**
1. Emission level (dBuV/m) = Raw Value (dBuV) + Correction Factor (dB/m).
 2. Correction Factor (dB/m) = Antenna Factor (dB/m) + Cable Factor (dB).
 3. The other emission levels were very low against the limit.
 4. Margin value = Emission level – Limit value.



A D T

5.2 CONDUCTED EMISSION MEASUREMENT

5.2.1 LIMITS OF CONDUCTED EMISSION MEASUREMENT

FREQUENCY OF EMISSION (MHz)	CONDUCTED LIMIT (dB μ V)	
	Quasi-peak	Average
0.15 ~ 0.5	66 to 56	56 to 46
0.5 ~ 5	56	46
5 ~ 30	60	50

- NOTE:** 1. The lower limit shall apply at the transition frequencies.
2. The limit decreases in line with the logarithm of the frequency in the range of 0.15 to 0.50MHz.
3. All emanations from a class A/B digital device or system, including any network of conductors and apparatus connected thereto, shall not exceed the level of field strengths specified above.

5.2.2 TEST INSTRUMENTS

DESCRIPTION & MANUFACTURER	MODEL NO.	SERIAL NO.	DATE OF CALIBRATION	DUE DATE OF CALIBRATION
Test Receiver ROHDE & SCHWARZ	ESCS30	100291	Dec. 16, 2009	Dec. 15, 2010
RF signal cable Woken	5D-FB	Cable-HYC01-01	Nov. 12, 2009	Nov. 11, 2010
LISN ROHDE & SCHWARZ	ESH3-Z5	100312	Jun. 28, 2010	Jun. 27, 2011
LISN ROHDE & SCHWARZ	ESH3-Z5	835239/001	Feb. 10, 2010	Feb. 09, 2011
Software ADT	ADT_Cond_ V7.3.7	NA	NA	NA

- NOTE:** 1. The calibration interval of the above test instruments is 12 months and the calibrations are traceable to NML/ROC and NIST/USA.
2. The test was performed in HwaYa Shielded Room 1.
3. The VCCI Site Registration No. is C-2040.



A D T

5.2.3 TEST PROCEDURES

- a. The EUT was placed 0.4 meters from the conducting wall of the shielded room with EUT being connected to the power mains through a line impedance stabilization network (LISN). Other support units were connected to the power mains through another LISN. The two LISNs provide 50 ohm/ 50uH of coupling impedance for the measuring instrument.
- b. Both lines of the power mains connected to the EUT were checked for maximum conducted interference.
- c. The frequency range from 150kHz to 30MHz was searched. Emission levels under (Limit - 20dB) was not recorded.

5.2.4 DEVIATION FROM TEST STANDARD

No deviation

5.2.5 TEST SETUP

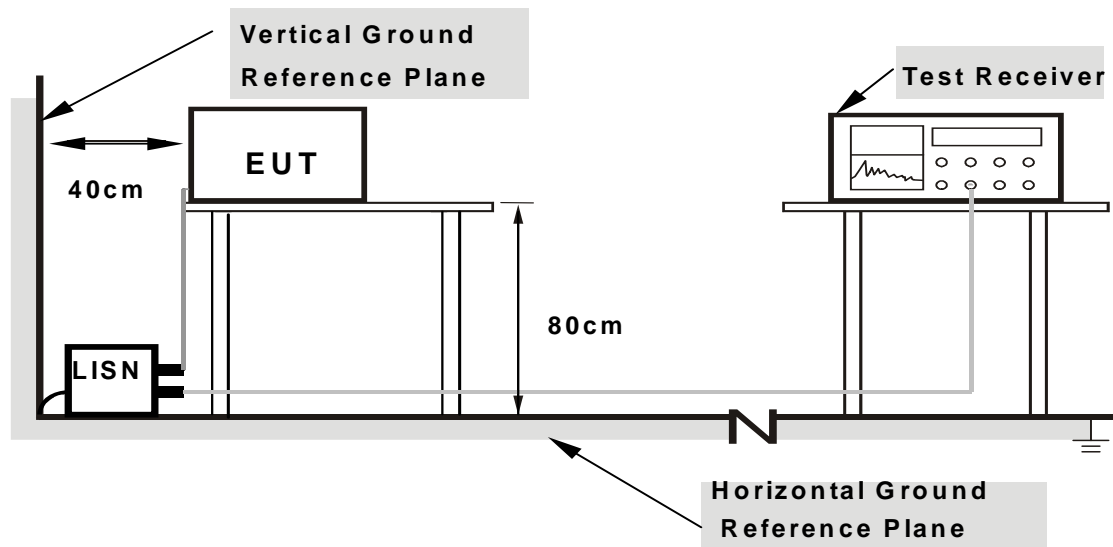

- Note:**
1. Support units were connected to second LISN.
 2. Both of LISNs (AMN) are 80 cm from EUT and at least 80 from other units and other metal planes

For the actual test configuration, please refer to the attached file (Test Setup Photo).

5.2.6 EUT OPERATING CONDITIONS

Same as 4.1.6

5.2.7 TEST RESULTS

CONDUCTED WORST-CASE DATA : 802.11n (20MHz)

PHASE	Line 1	6dB BANDWIDTH	9kHz
-------	--------	---------------	------

No	Freq. [MHz]	Corr. Factor (dB)	Reading Value		Emission Level		Limit		Margin	
			[dB (uV)]		[dB (uV)]		[dB (uV)]		(dB)	
			Q.P.	AV.	Q.P.	AV.	Q.P.	AV.	Q.P.	AV.
1	0.150	0.12	54.15	-	54.27	-	66.00	56.00	-11.73	-
2	0.205	0.11	47.71	-	47.82	-	63.42	53.42	-15.60	-
3	0.271	0.12	39.75	-	39.87	-	61.08	51.08	-21.22	-
4	0.591	0.15	32.02	-	32.17	-	56.00	46.00	-23.83	-
5	3.281	0.31	32.31	-	32.62	-	56.00	46.00	-23.38	-
6	6.766	0.48	39.84	-	40.32	-	60.00	50.00	-19.68	-

- REMARKS:**
1. Q.P. and AV. are abbreviations of quasi-peak and average individually.
 2. "-": The Quasi-peak reading value also meets average limit and measurement with the average detector is unnecessary.
 3. The emission levels of other frequencies were very low against the limit.
 4. Margin value = Emission level - Limit value
 5. Correction factor = Insertion loss + Cable loss
 6. Emission Level = Correction Factor + Reading Value.

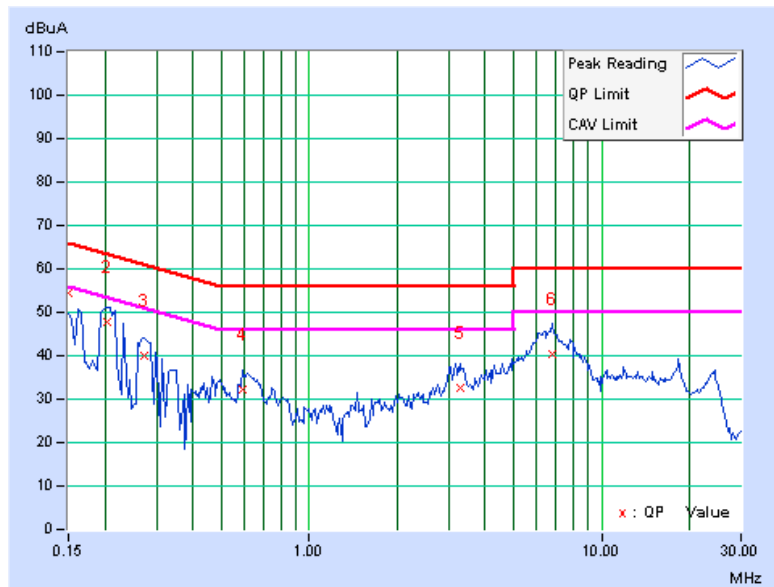

PHASE	Line 2	6dB BANDWIDTH	9kHz
-------	--------	---------------	------

No	Freq.	Corr.	Reading Value		Emission Level		Limit		Margin	
	[MHz]	Factor (dB)	[dB (uV)]		[dB (uV)]		[dB (uV)]		(dB)	
			Q.P.	AV.	Q.P.	AV.	Q.P.	AV.	Q.P.	AV.
1	0.150	0.10	53.99	-	54.09	-	66.00	56.00	-11.91	-
2	0.213	0.10	47.03	-	47.13	-	63.11	53.11	-15.98	-
3	0.271	0.11	39.59	-	39.70	-	61.08	51.08	-21.39	-
4	0.591	0.14	32.26	-	32.40	-	56.00	46.00	-23.60	-
5	3.465	0.30	31.27	-	31.57	-	56.00	46.00	-24.43	-
6	6.527	0.42	39.35	-	39.77	-	60.00	50.00	-20.23	-

- REMARKS:**
1. Q.P. and AV. are abbreviations of quasi-peak and average individually.
 2. "-": The Quasi-peak reading value also meets average limit and measurement with the average detector is unnecessary.
 3. The emission levels of other frequencies were very low against the limit.
 4. Margin value = Emission level - Limit value
 5. Correction factor = Insertion loss + Cable loss
 6. Emission Level = Correction Factor + Reading Value.

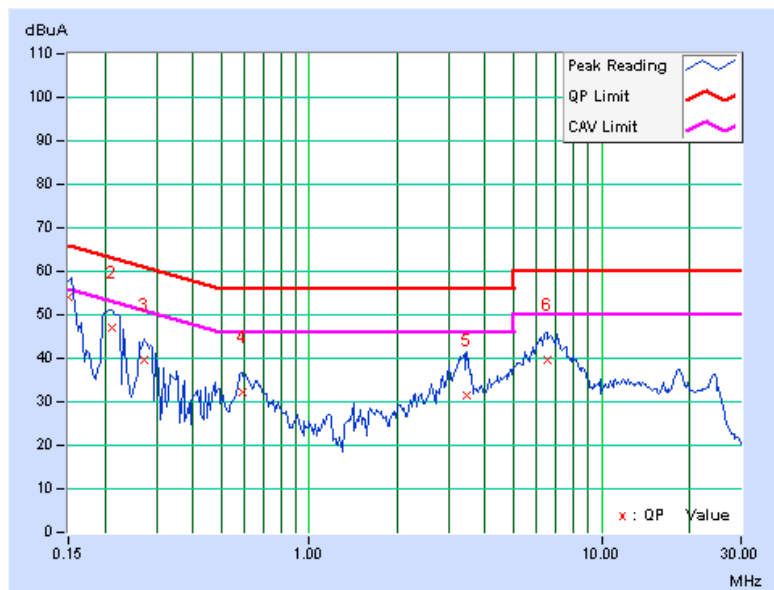



A D T

5.3 6dB BANDWIDTH MEASUREMENT

5.3.1 LIMITS OF 6dB BANDWIDTH MEASUREMENT

The minimum of 6dB Bandwidth Measurement is 0.5MHz.

5.3.2 TEST INSTRUMENTS

DESCRIPTION & MANUFACTURER	MODEL NO.	SERIAL NO.	DATE OF CALIBRATION	DUE DATE OF CALIBRATION
SPECTRUM ANALYZER R&S	FSP40	100039	Jan. 11, 2010	Jan. 10, 2011

NOTE: The calibration interval of the above test instruments is 12 months and the calibrations are traceable to NML/ROC and NIST/USA.

5.3.3 TEST PROCEDURE

The transmitter output was connected to the spectrum analyzer through an attenuator. The bandwidth of the fundamental frequency was measured by spectrum analyzer with 100kHz RBW and 300kHz VBW. The 6dB bandwidth is defined as the total spectrum the power of which is higher than peak power minus 6dB.

5.3.4 DEVIATION FROM TEST STANDARD

No deviation

5.3.5 TEST SETUP

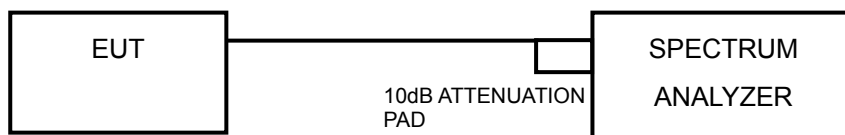

5.3.6 EUT OPERATING CONDITIONS

The software provided by client to enable the EUT under transmission condition continuously at lowest, middle and highest channel frequencies individually.



A D T

5.3.7 TEST RESULTS

802.11a (Antenna A)

CHANNEL	CHANNEL FREQUENCY (MHz)	6dB BANDWIDTH (MHz)	MINIMUM LIMIT (MHz)	PASS / FAIL
149	5745	15.35	0.5	PASS
157	5785	15.38	0.5	PASS
165	5825	15.20	0.5	PASS

CH 157

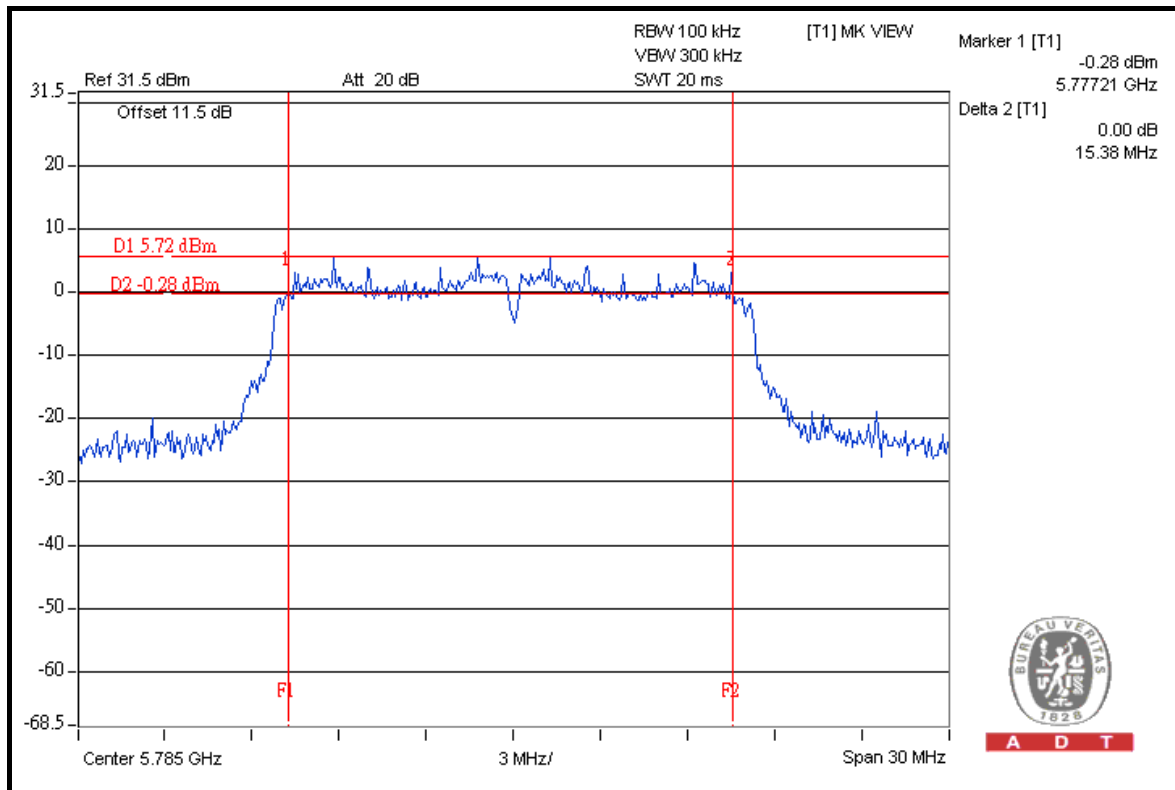



A D T

802.11a (Antenna B)

CHANNEL	CHANNEL FREQUENCY (MHz)	6dB BANDWIDTH (MHz)	MINIMUM LIMIT (MHz)	PASS / FAIL
149	5745	15.43	0.5	PASS
157	5785	15.21	0.5	PASS
165	5825	15.36	0.5	PASS

CH 149

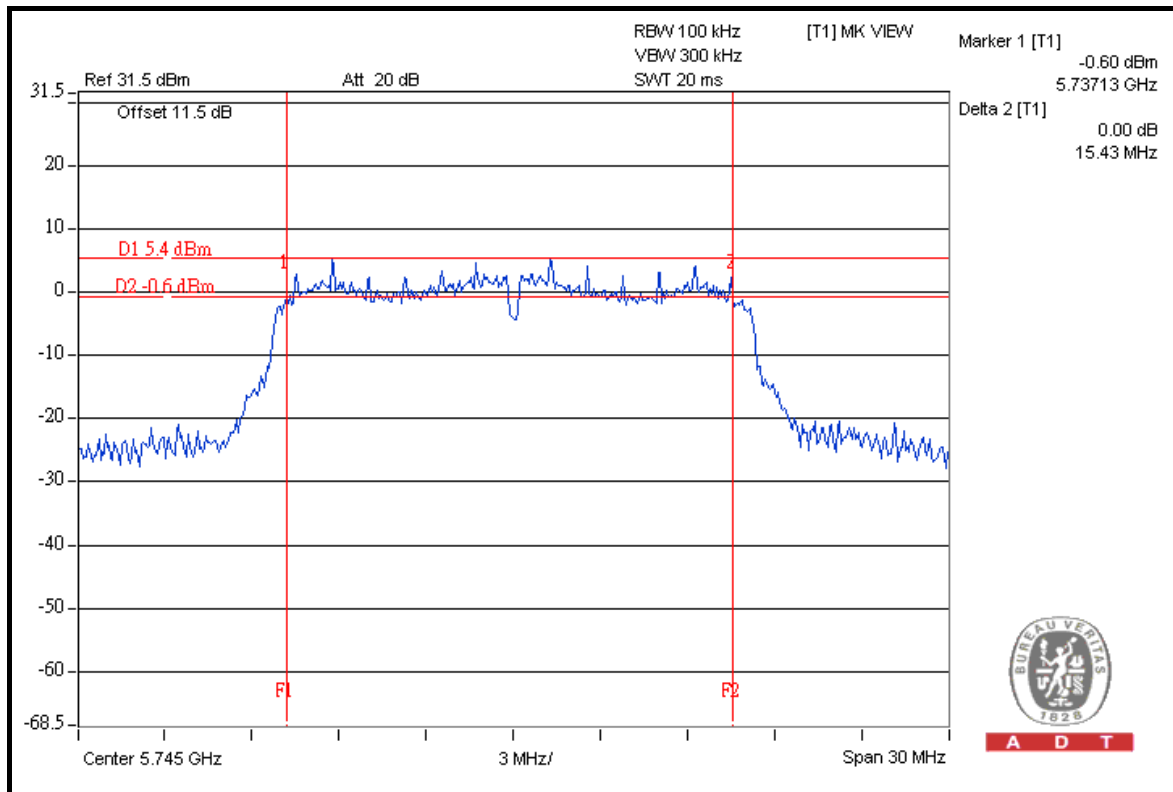

A D T



A D T

802.11n (20MHz)

CHANNEL	CHANNEL FREQUENCY (MHz)	6dB BANDWIDTH (MHz)		MINIMUM LIMIT (MHz)	PASS / FAIL
		CHAIN 0	CHAIN 1		
149	5745	15.18	15.18	0.5	PASS
157	5785	15.16	15.20	0.5	PASS
165	5825	15.21	15.19	0.5	PASS

FOR CHAIN 0: CH 165

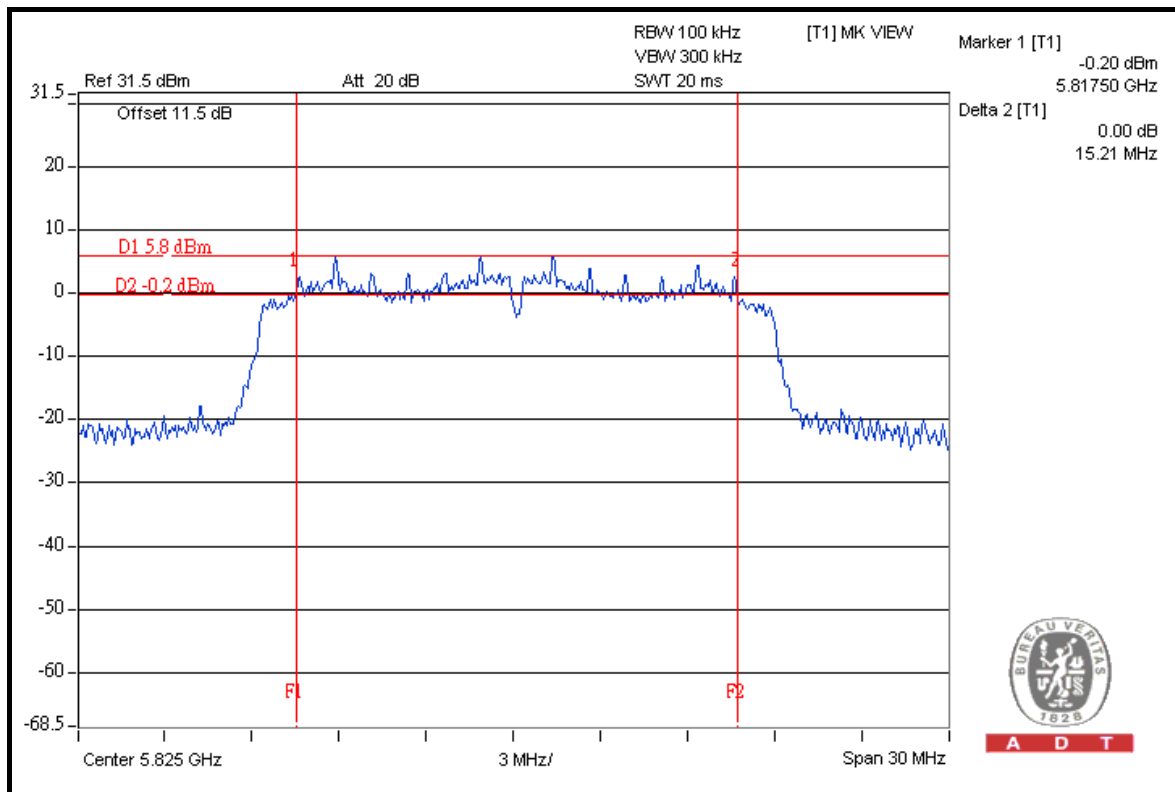



A D T

802.11n (40MHz)

CHANNEL	CHANNEL FREQUENCY (MHz)	6dB BANDWIDTH (MHz)		MINIMUM LIMIT (MHz)	PASS / FAIL
		CHAIN 0	CHAIN 1		
151	5755	35.47	35.45	0.5	PASS
159	5795	35.12	35.18	0.5	PASS

FOR CHAIN 0: CH 151

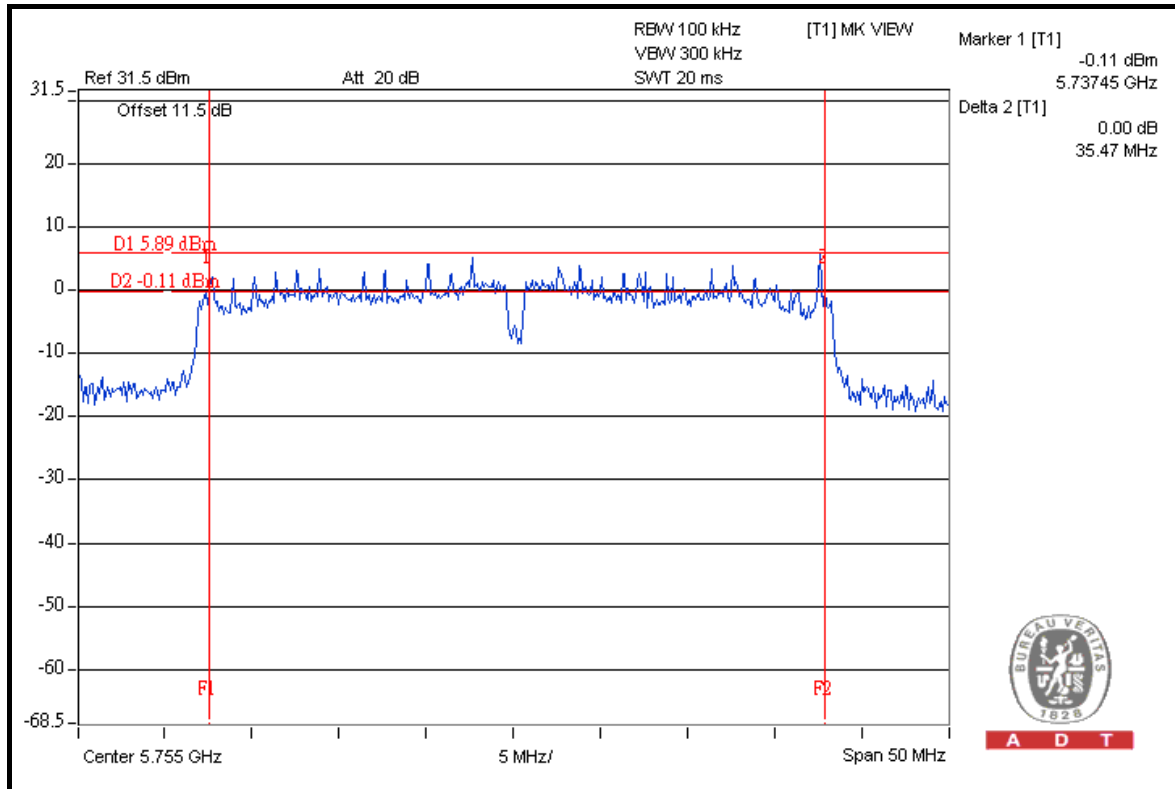

A D T



A D T

5.4 MAXIMUM OUTPUT POWER

5.4.1 LIMITS OF MAXIMUM OUTPUT POWER MEASUREMENT

The Maximum Peak Output Power Measurement is 30dBm.

5.4.2 INSTRUMENTS

DESCRIPTION & MANUFACTURER	MODEL NO.	SERIAL NO.	DATE OF CALIBRATION	DUE DATE OF CALIBRATION
High Speed Peak Power Meter	ML2495A	0842014	Apr. 21, 2010	Apr. 20, 2011
Power Sensor	MA2411B	0738404	Apr. 21, 2010	Apr. 20, 2011

Note:

1. The calibration interval of the above test instruments is 12 months and the calibrations are traceable to NML/ROC and NIST/USA.
2. Measurement Bandwidth of ML2495A is 65MHz greater than 6dB bandwidth of emission.

5.4.3 TEST PROCEDURES

A power sensor was used on the output port of the EUT. A power meter was used to read the response of the power sensor. Record the power level.

5.4.4 DEVIATION FROM TEST STANDARD

No deviation

5.4.5 TEST SETUP

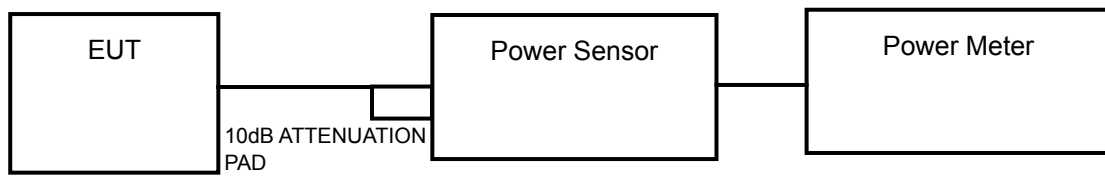

5.4.6 EUT OPERATING CONDITIONS

Same as Item 5.3.6



5.4.7 TEST RESULTS

802.11a (Antenna A)

CHAN	CHANNEL FREQUENCY (MHz)	POWER OUTPUT (mW)	POWER OUTPUT (dBm)	POWER LIMIT (dBm)	PASS/FAIL
149	5745	208.9	23.2	30	PASS
157	5785	204.2	23.1	30	PASS
165	5825	213.8	23.3	30	PASS

802.11a (Antenna B)

CHAN	CHANNEL FREQUENCY (MHz)	POWER OUTPUT (mW)	POWER OUTPUT (dBm)	POWER LIMIT (dBm)	PASS/FAIL
149	5745	204.2	23.1	30	PASS
157	5785	208.9	23.2	30	PASS
165	5825	199.5	23.0	30	PASS

802.11n (20MHz)

CHAN.	CHAN. FREQ. (MHz)	POWER OUTPUT (dBm)		TOTAL POWER (mW)	TOTAL POWER (dBm)	POWER LIMIT (dBm)	PASS / FAIL
		CHAIN 0	CHAIN 1				
149	5745	22.1	22.6	344.2	25.4	30	PASS
157	5785	22.2	22.8	356.5	25.5	30	PASS
165	5825	22.1	22.6	344.2	25.4	30	PASS

802.11n (40MHz)

CHAN.	CHAN. FREQ. (MHz)	POWER OUTPUT (dBm)		TOTAL POWER (mW)	TOTAL POWER (dBm)	POWER LIMIT (dBm)	PASS / FAIL
		CHAIN 0	CHAIN 1				
151	5755	21.9	22.4	328.7	25.2	30	PASS
159	5795	22.1	22.8	352.7	25.5	30	PASS



A D T

5.5 POWER SPECTRAL DENSITY MEASUREMENT

5.5.1 LIMITS OF POWER SPECTRAL DENSITY MEASUREMENT

The Maximum of Power Spectral Density Measurement is 8dBm.

5.5.2 TEST INSTRUMENTS

DESCRIPTION & MANUFACTURER	MODEL NO.	SERIAL NO.	DATE OF CALIBRATION	DUE DATE OF CALIBRATION
SPECTRUM ANALYZER R&S	FSP40	100039	Jan. 11, 2010	Jan. 10, 2011

NOTE: The calibration interval of the above test instruments is 12 months and the calibrations are traceable to NML/ROC and NIST/USA.

5.5.3 TEST PROCEDURE

The transmitter output was connected to the spectrum analyzer through an attenuator, the bandwidth of the fundamental frequency was measured with the spectrum analyzer using 3kHz RBW and 30kHz VBW, set sweep time = span/3kHz. The power spectral density was measured and recorded.

The sweep time is allowed to be longer than span/3kHz for a full response of the mixer in the spectrum analyzer.



A D T

5.5.4 DEVIATION FROM TEST STANDARD

No deviation

5.5.5 TEST SETUP

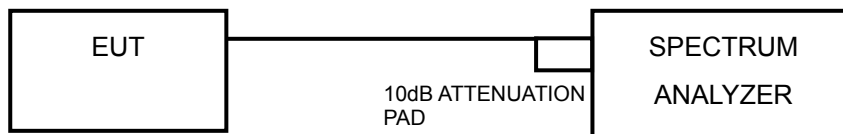

5.5.6 EUT OPERATING CONDITION

Same as Item 5.3.6



A D T

5.5.7 TEST RESULTS

802.11a (Antenna A)

CHANNEL	CHANNEL FREQUENCY (MHz)	RF POWER LEVEL IN 3 kHz BW (dBm)	MAXIMUM LIMIT (dBm)	PASS/FAIL
149	5745	-9.2	8	PASS
157	5785	-9.0	8	PASS
165	5825	-9.1	8	PASS

CH 157

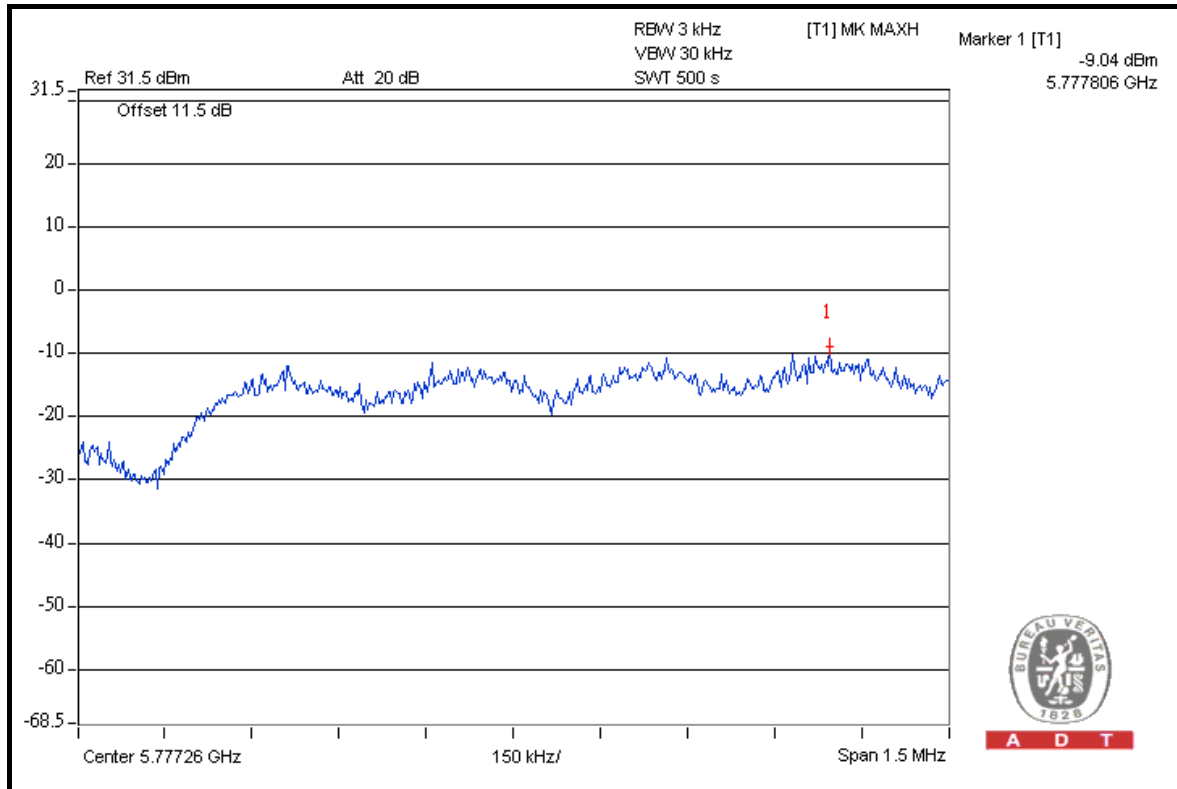



A D T

802.11a (Antenna B)

CHANNEL	CHANNEL FREQUENCY (MHz)	RF POWER LEVEL IN 3 kHz BW (dBm)	MAXIMUM LIMIT (dBm)	PASS/FAIL
149	5745	-8.4	8	PASS
157	5785	-8.1	8	PASS
165	5825	-8.2	8	PASS

CH 157

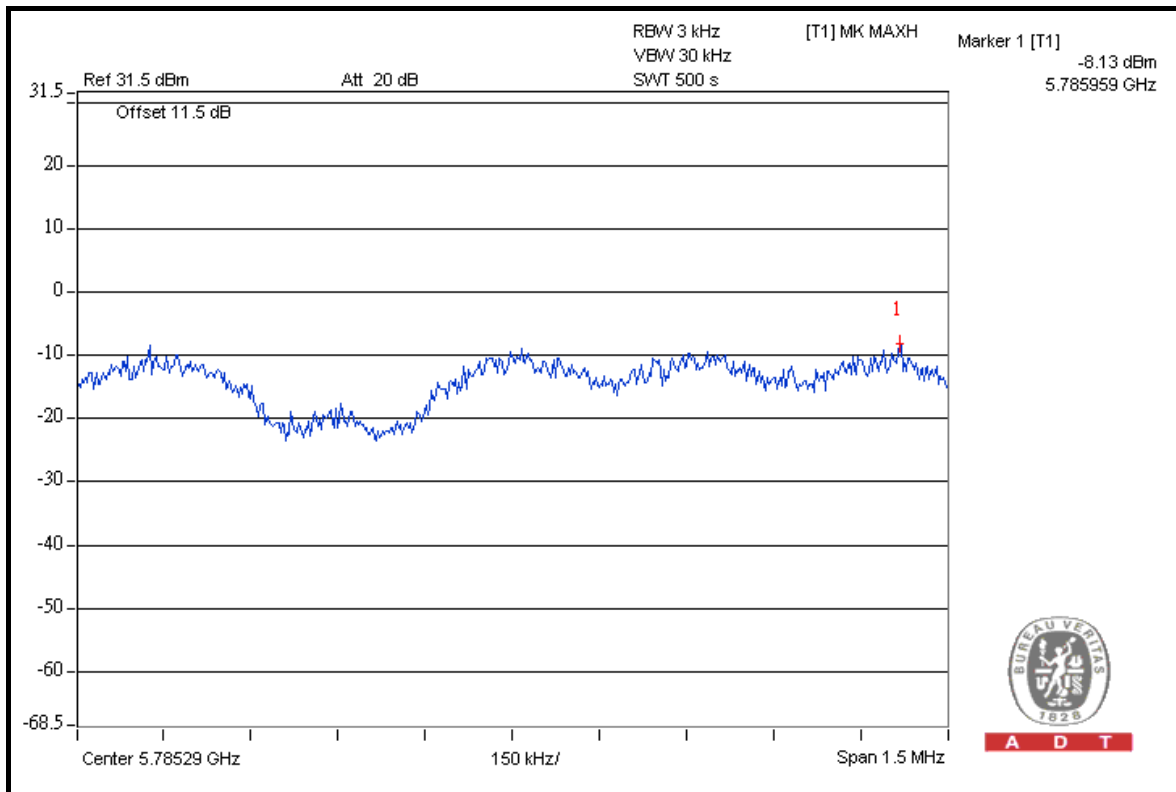

A D T



A D T

802.11n (20MHz)

CHAN.	CHAN. FREQ. (MHz)	RF POWER LEVEL IN 3kHz BW (dBm)		TOTAL POWER DENSITY (dBm)	MAX. LIMIT (dBm)	PASS / FAIL
		CHAIN 0	CHAIN 1			
149	5745	-8.5	-7.0	-4.7	8	PASS
157	5785	-7.7	-6.7	-4.2	8	PASS
165	5825	-8.3	-7.0	-4.6	8	PASS

FOR CHAIN 1: CH 157

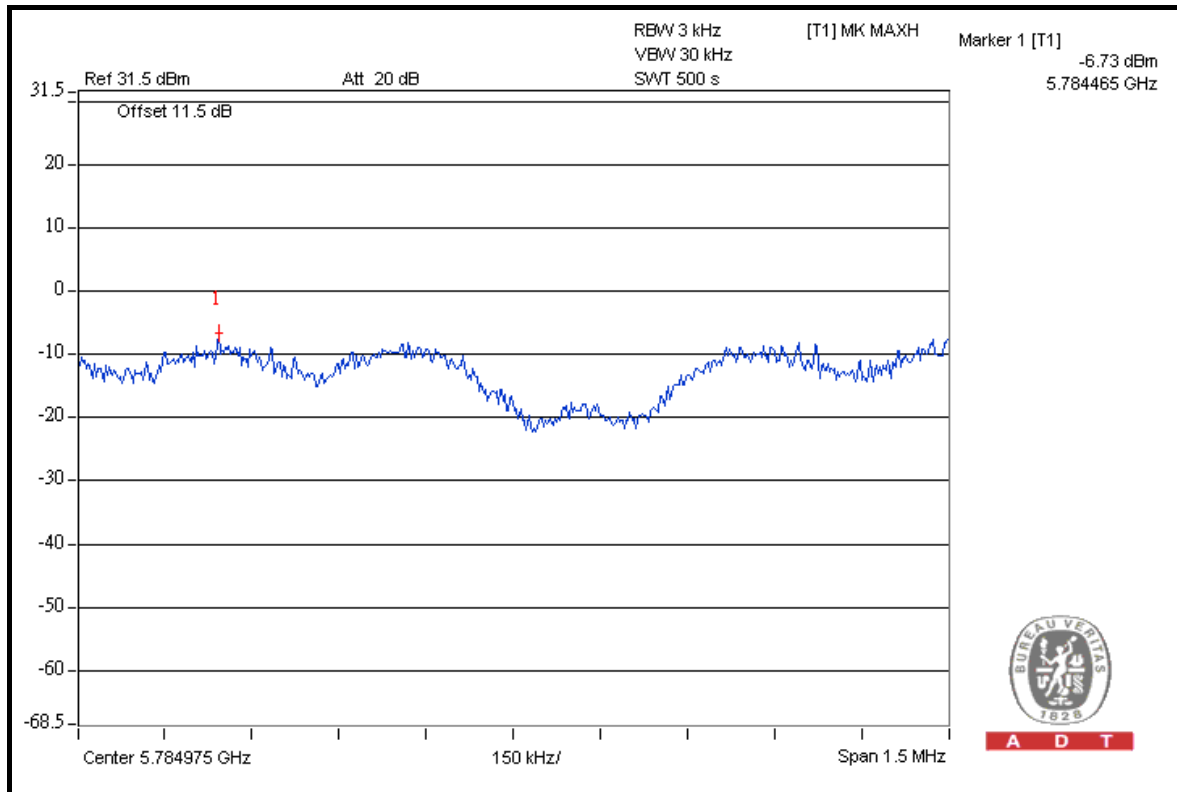

A D T



A D T

802.11n (40MHz)

CHAN.	CHAN. FREQ. (MHz)	RF POWER LEVEL IN 3kHz BW (dBm)		TOTAL POWER DENSITY (dBm)	MAX. LIMIT (dBm)	PASS / FAIL
		CHAIN 0	CHAIN 1			
151	5755	-10.7	-9.1	-6.8	8	PASS
159	5795	-10.3	-8.7	-6.4	8	PASS

FOR CHAIN 1: CH 159

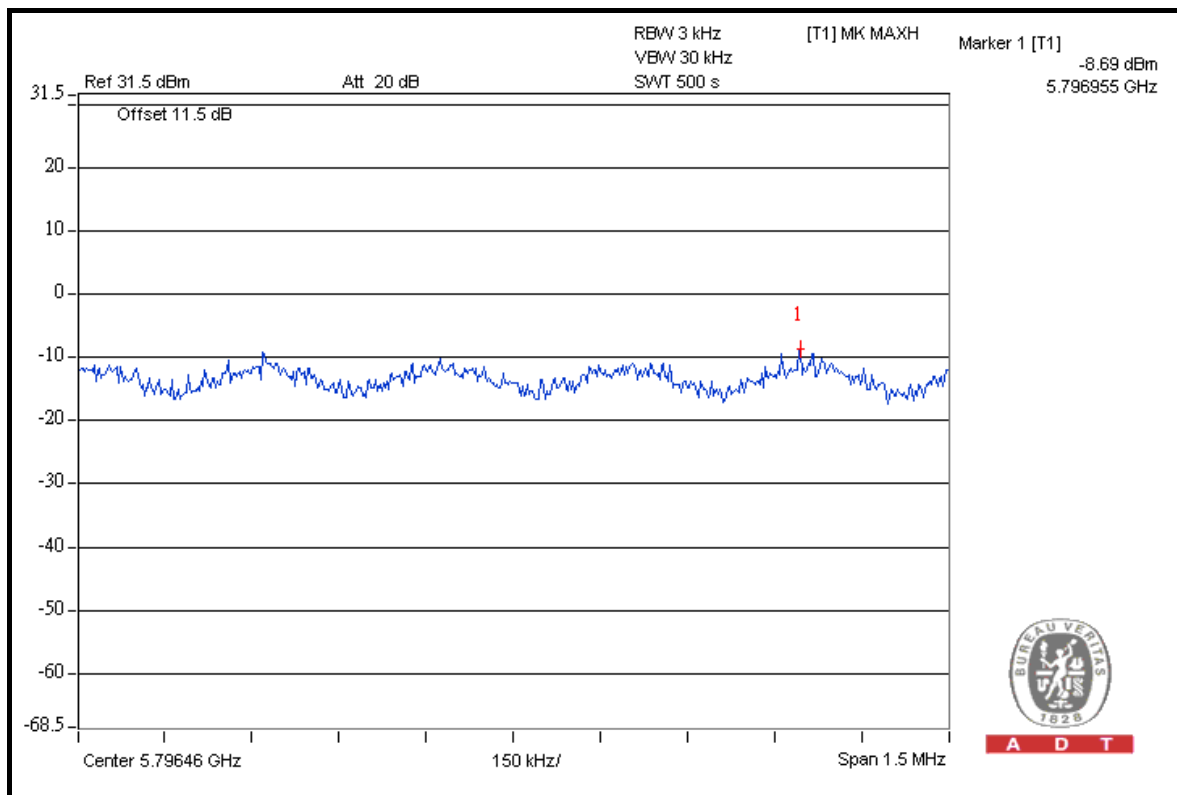



A D T

5.6 BAND EDGES MEASUREMENT

5.6.1 LIMITS OF BAND EDGES MEASUREMENT

Below -20dB of the highest emission level of operating band (in 100kHz Resolution Bandwidth).

5.6.2 TEST INSTRUMENTS

DESCRIPTION & MANUFACTURER	MODEL NO.	SERIAL NO.	DATE OF CALIBRATION	CALIBRATED UNTIL
FOR CONDUCTED MEASUREMENT				
SPECTRUM ANALYZER R&S	FSP40	100039	Jan. 11, 2010	Jan. 10, 2011
FOR RADIATED MEASUREMENT				
Test Receiver ROHDE & SCHWARZ	ESIB7	100188	Dec. 21, 2009	Dec. 20, 2010
Spectrum Analyzer ROHDE & SCHWARZ	FSP40	100041	Jul. 09, 2010	Jul. 08, 2011
BILOG Antenna SCHWARZBECK	VULB9168	9168-156	Apr. 30, 2010	Apr. 29, 2011
HORN Antenna SCHWARZBECK	BBHA 9120 D	9120D-209	Aug. 02, 2010	Aug. 01, 2011
HORN Antenna SCHWARZBECK	BBHA 9170	BBHA9170242	Dec. 25, 2009	Dec. 24, 2010
Preamplifier Agilent	8447D	2944A10629	Nov. 04, 2009	Nov. 03, 2010
Preamplifier Agilent	8449B	3008A01959	Dec. 10, 2009	Dec. 09, 2010
RF signal cable HUBER+SUHNNER	SUCOFLEX 104	238141/4	May 14, 2010	May 13, 2011
RF signal cable HUBER+SUHNNER	SUCOFLEX 104	12738/6	May 14, 2010	May 13, 2011
Software	ADT_Radiated_ V7.6.15.9.2	NA	NA	NA
Antenna Tower EMCO	2070/2080	512.835.4684	NA	NA
Turn Table EMCO	2087-2.03	NA	NA	NA
Antenna Tower & Turn Table Controller EMCO	2090	NA	NA	NA
26GHz ~ 40GHz Amplifier	EM26400	07026401	Jul. 20, 2010	Jul. 19, 2011

NOTE: The calibration interval of the above test instruments is 12 months and the calibrations are traceable to NML/ROC and NIST/USA.



5.6.3 TEST PROCEDURE

FOR CONDUCTED MEASUREMENT

The transmitter output was connected to the spectrum analyzer via a low loss cable. Set both RBW and VBW of spectrum analyzer to 100kHz and 300kHz with suitable frequency span including 100MHz bandwidth from band edge. The band edges was measured and recorded.

The spectrum plots (Peak RBW = 100kHz, VBW = 300kHz; Average RBW = 1MHz, VBW = 10Hz) are attached on the following pages.

FOR RADIATED MEASUREMENT

- a. The EUT was placed on the top of a rotating table 0.8 meters above the ground at a 3 meter semi-anechoic chamber. The table was rotated 360 degrees to determine the position of the highest radiation.
- b. The EUT was set 3 meters away from the interference-receiving antenna, which was mounted on the top of a variable-height antenna tower.
- c. The antenna is a broadband antenna, and its height is varied from one meter to four meters above the ground to determine the maximum value of the field strength. Both horizontal and vertical polarizations of the antenna are set to make the measurement.
- d. For each suspected emission, the EUT was arranged to its worst case and then the antenna was tuned to heights from 1 meter to 4 meters and the rotatable table was turned from 0 degrees to 360 degrees to find the maximum reading.
- e. Set both RBW and VBW of spectrum analyzer to 100kHz and 300kHz with suitable frequency span including 100MHz bandwidth from band edge. The band edges was measured and recorded.

NOTE: The resolution bandwidth of test receiver/spectrum analyzer is 1MHz and the video bandwidth is 10Hz for Average detection (AV) at frequency above 1GHz.



A D T

5.6.4 DEVIATION FROM TEST STANDARD

No deviation

5.6.5 EUT OPERATING CONDITION

Same as Item 5.3.6

5.6.6 TEST RESULTS

The spectrum plots are attached on the following pages. D1 line indicates the highest level, D2 line indicates the 20dB offset below D1. It shows compliance with the requirement in part 15.247(d).



A D T

802.11a (Antenna A)

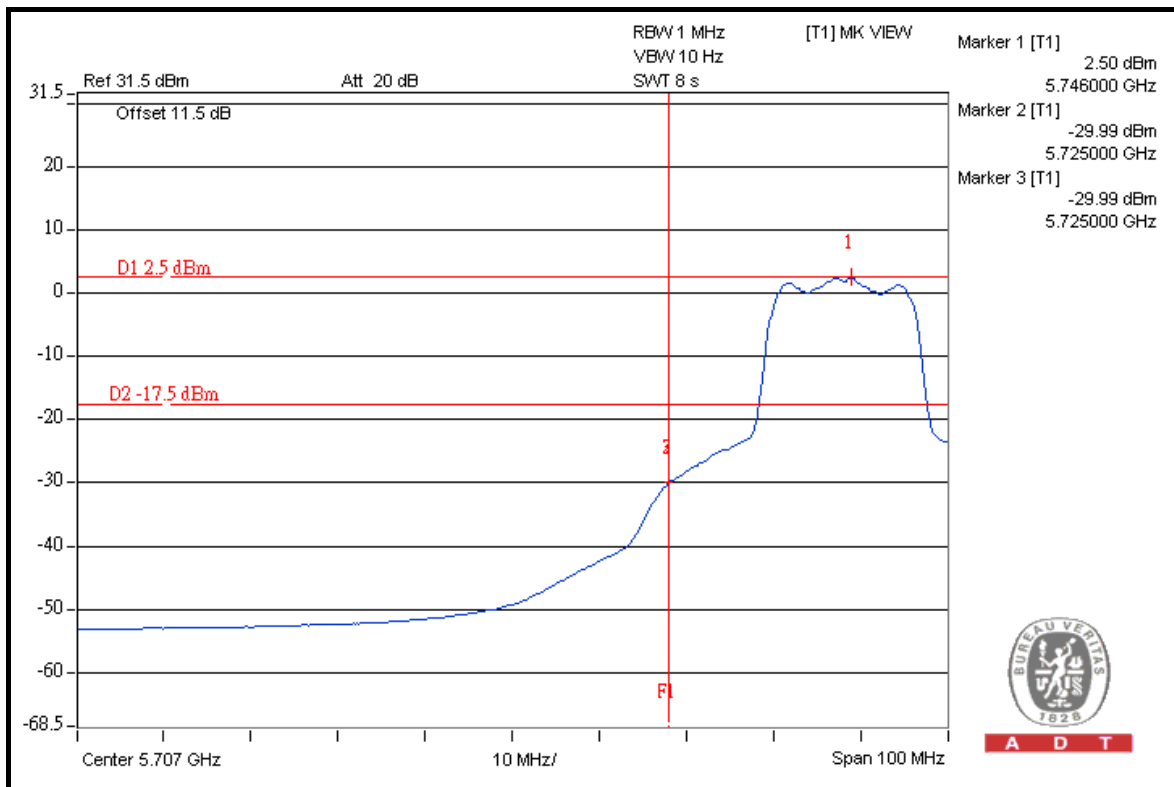
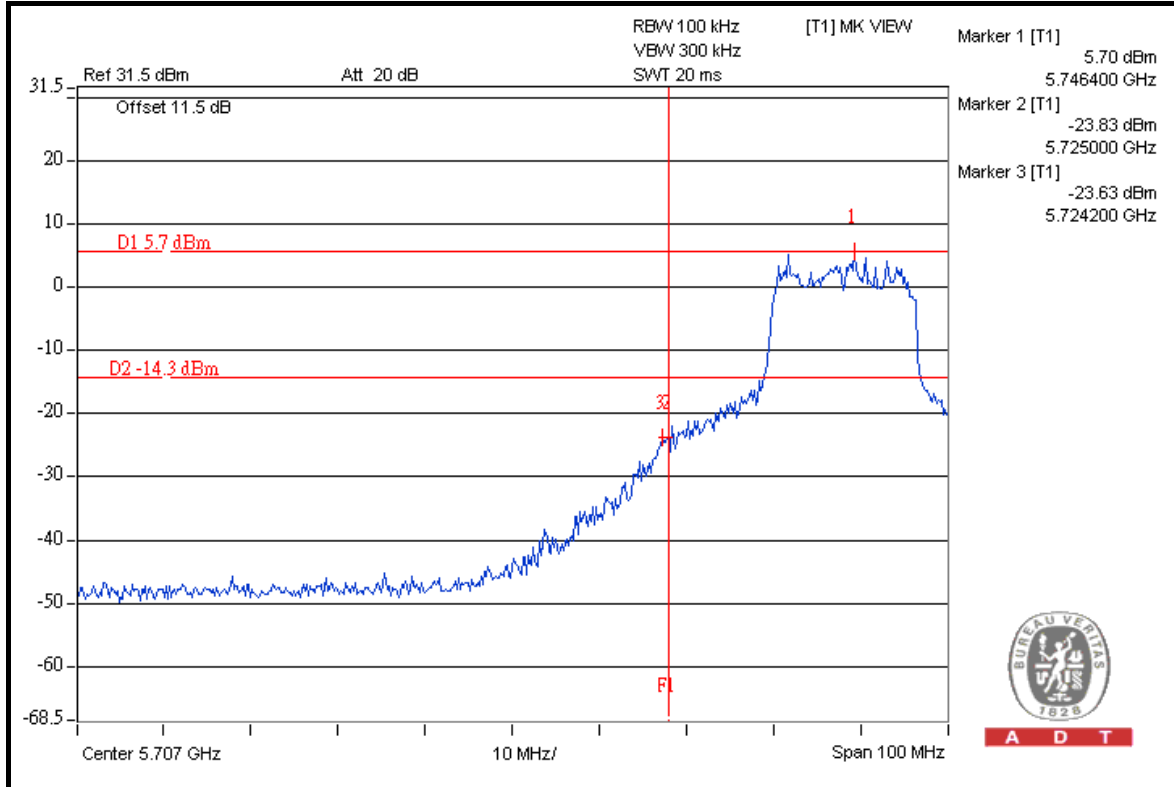



A D T

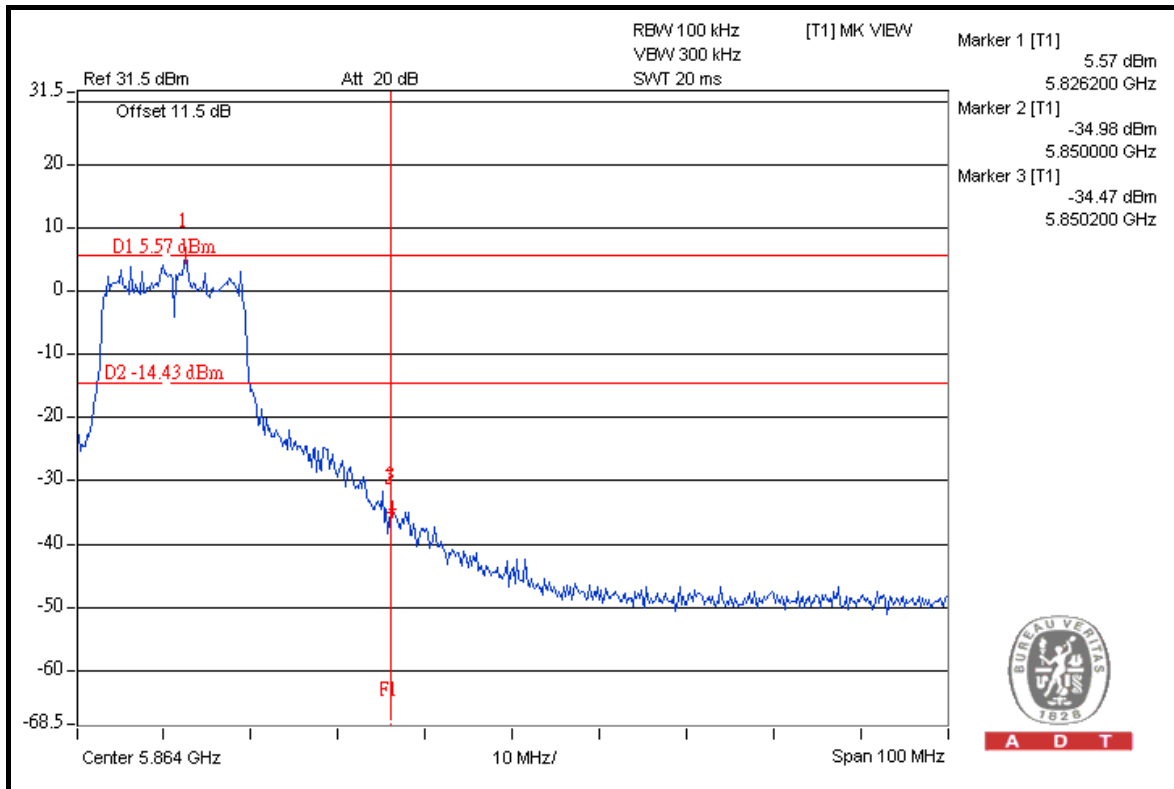
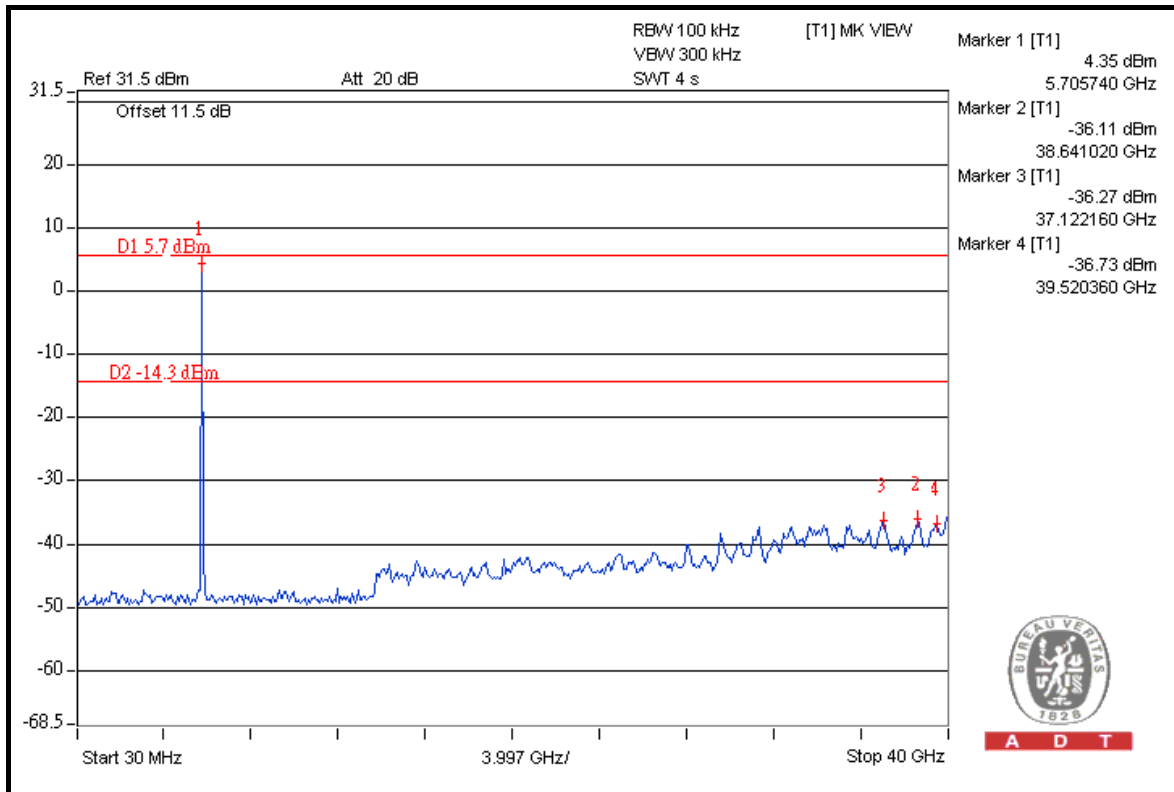



A D T

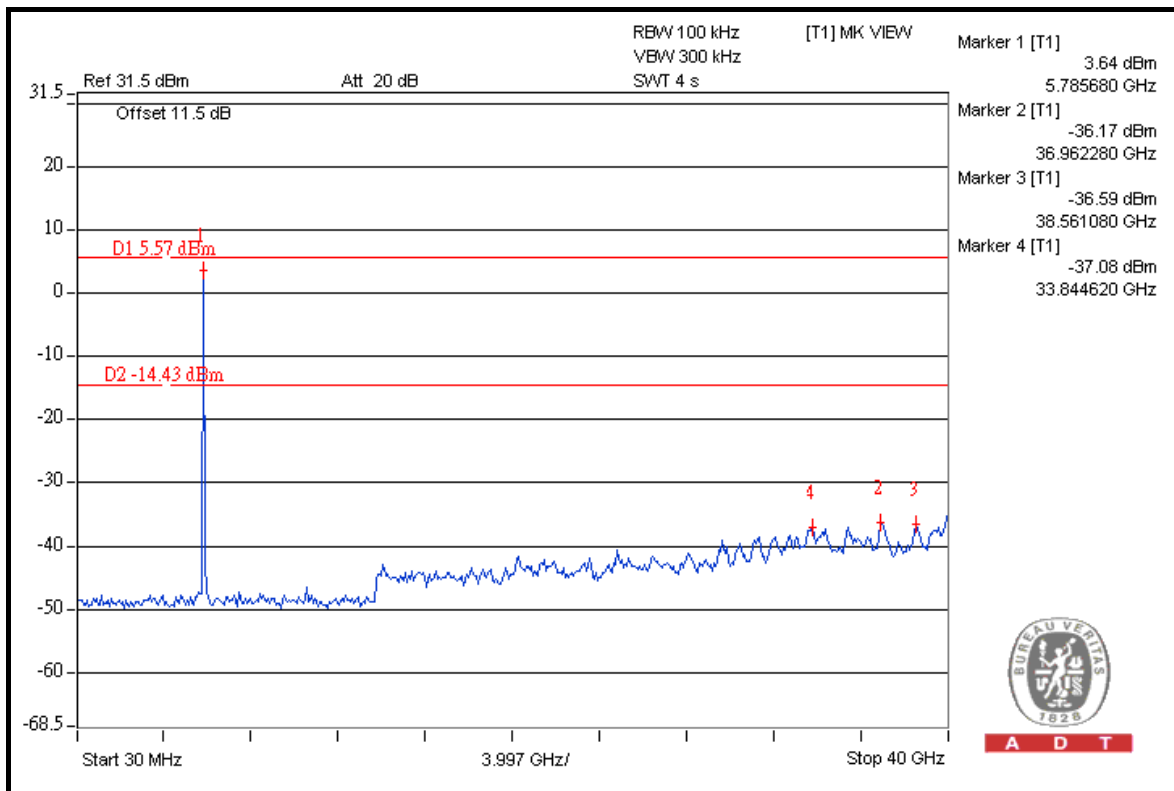
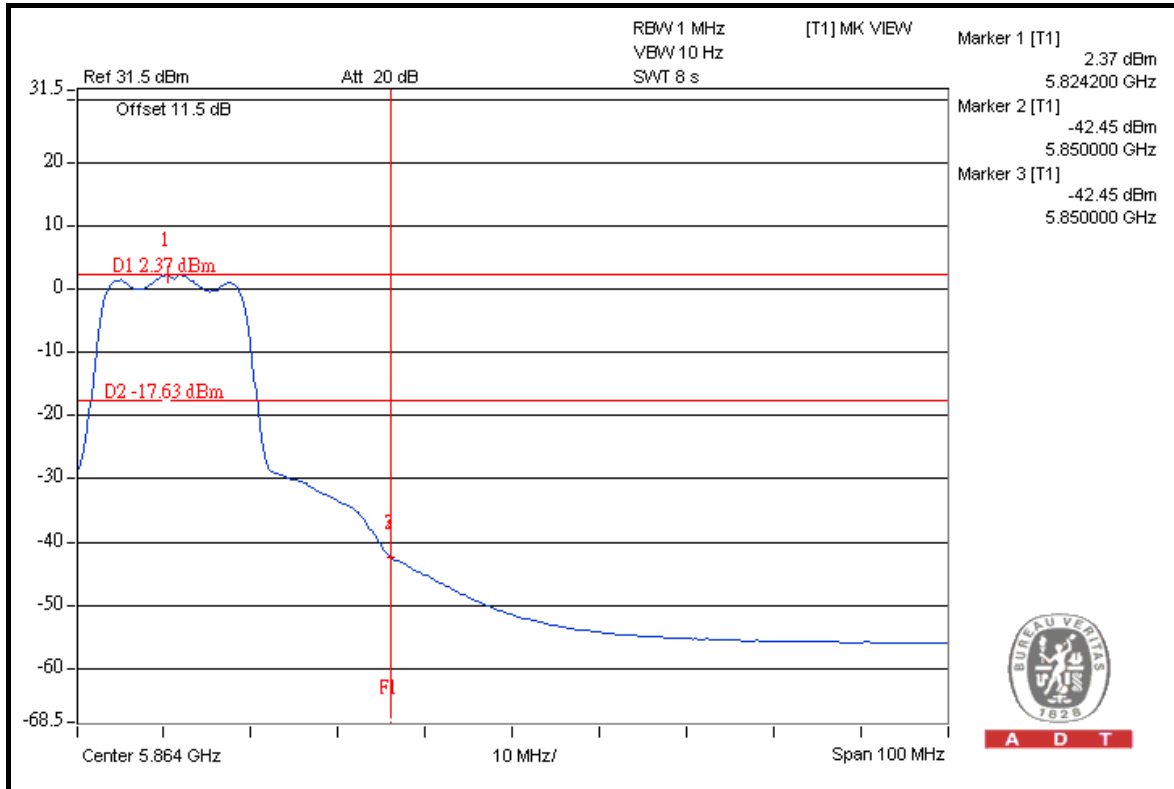



A D T

802.11a (Antenna B)

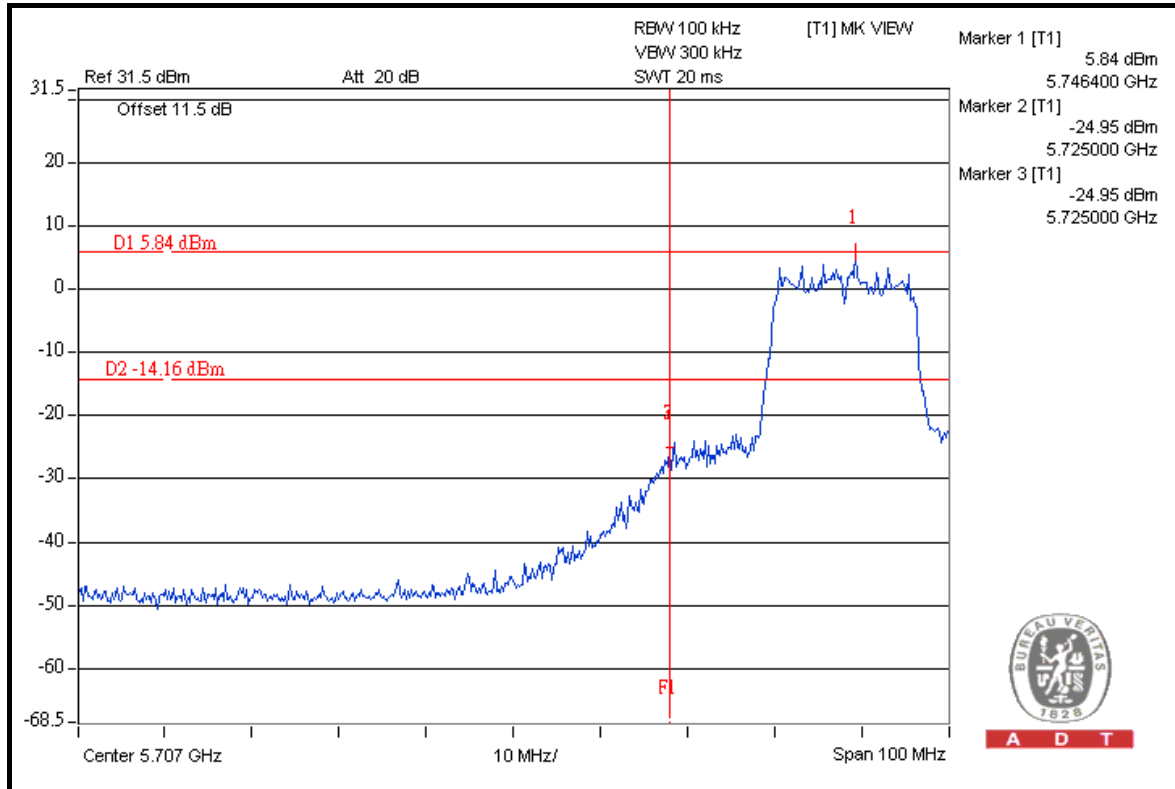

A D T

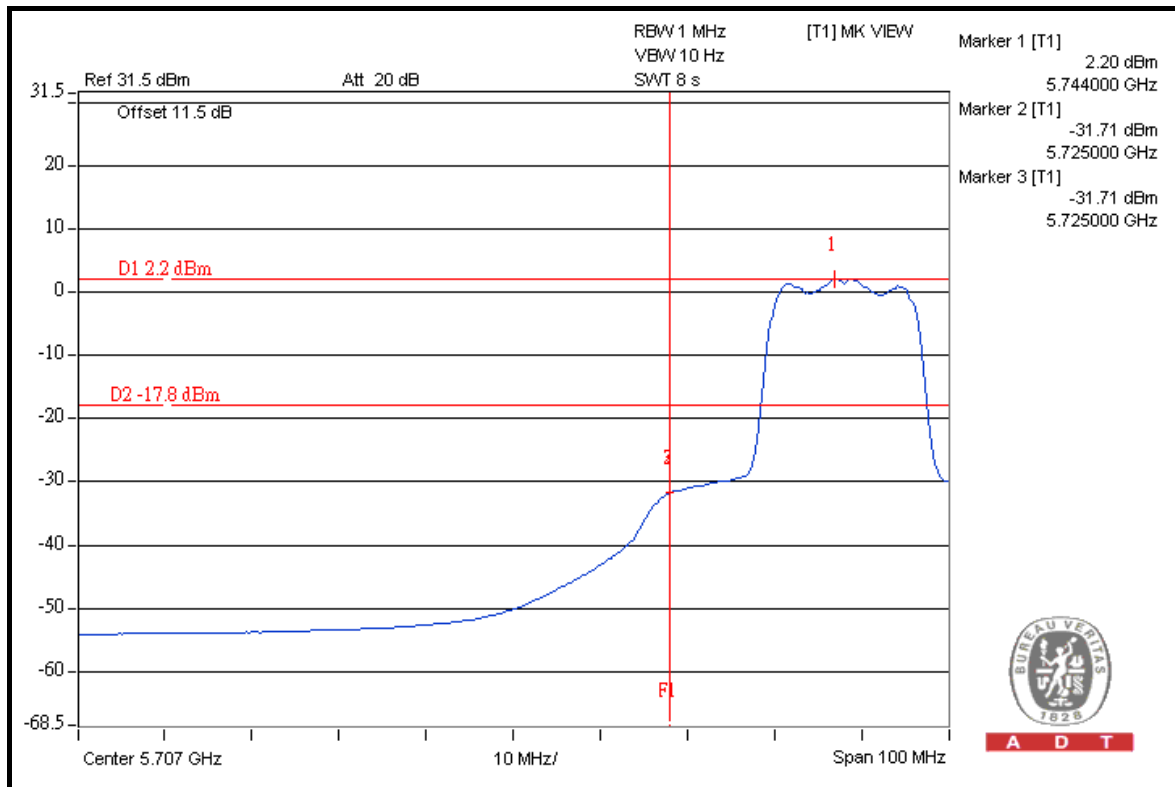

A D T



A D T

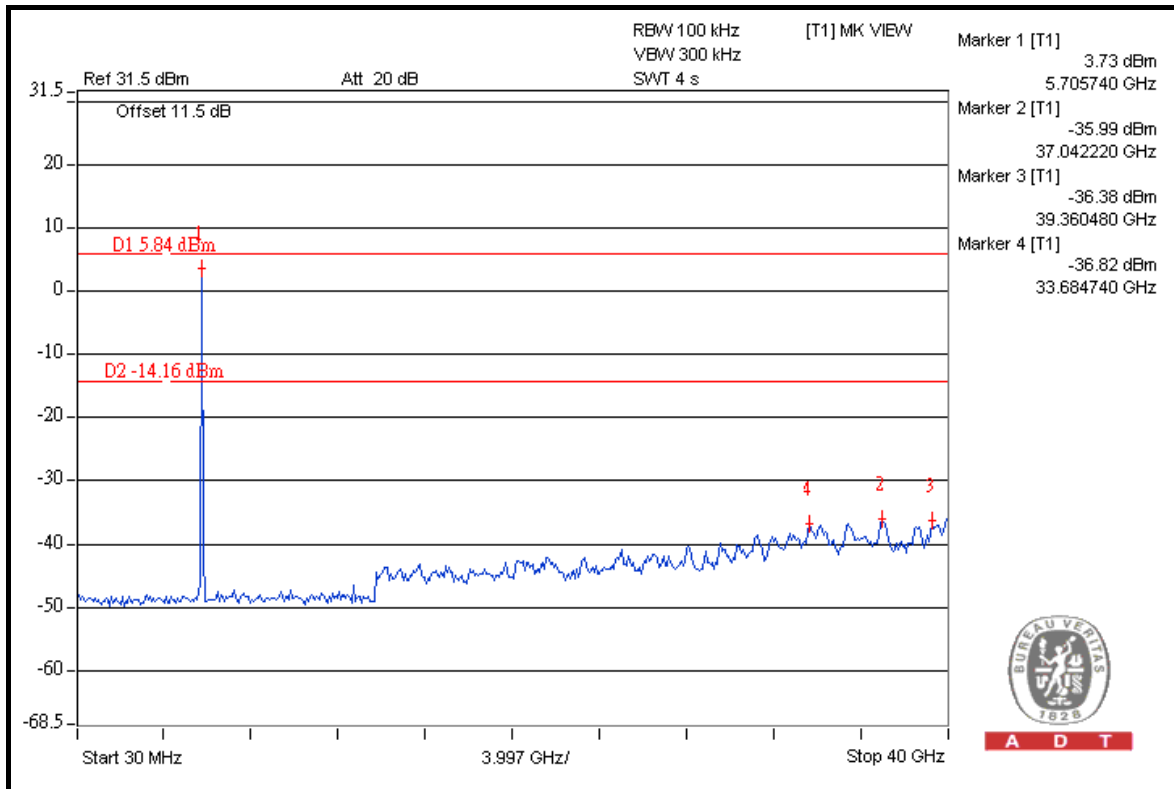

A D T

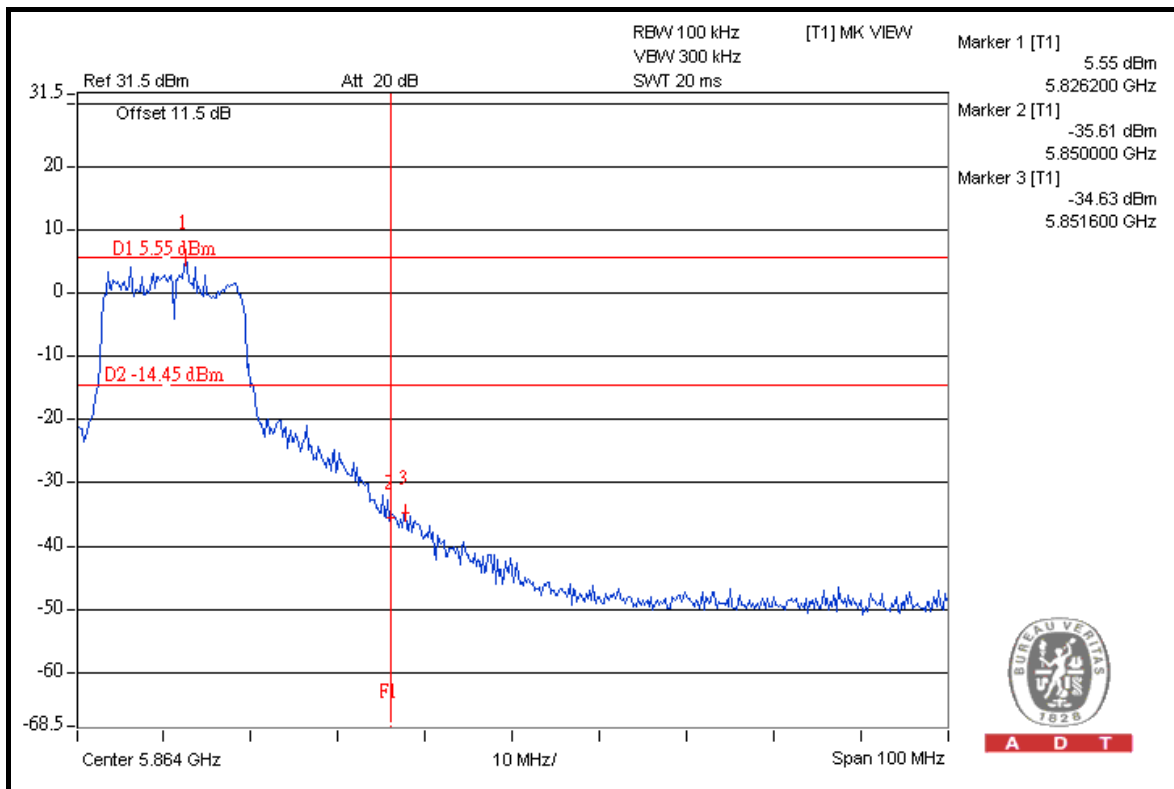

A D T



A D T

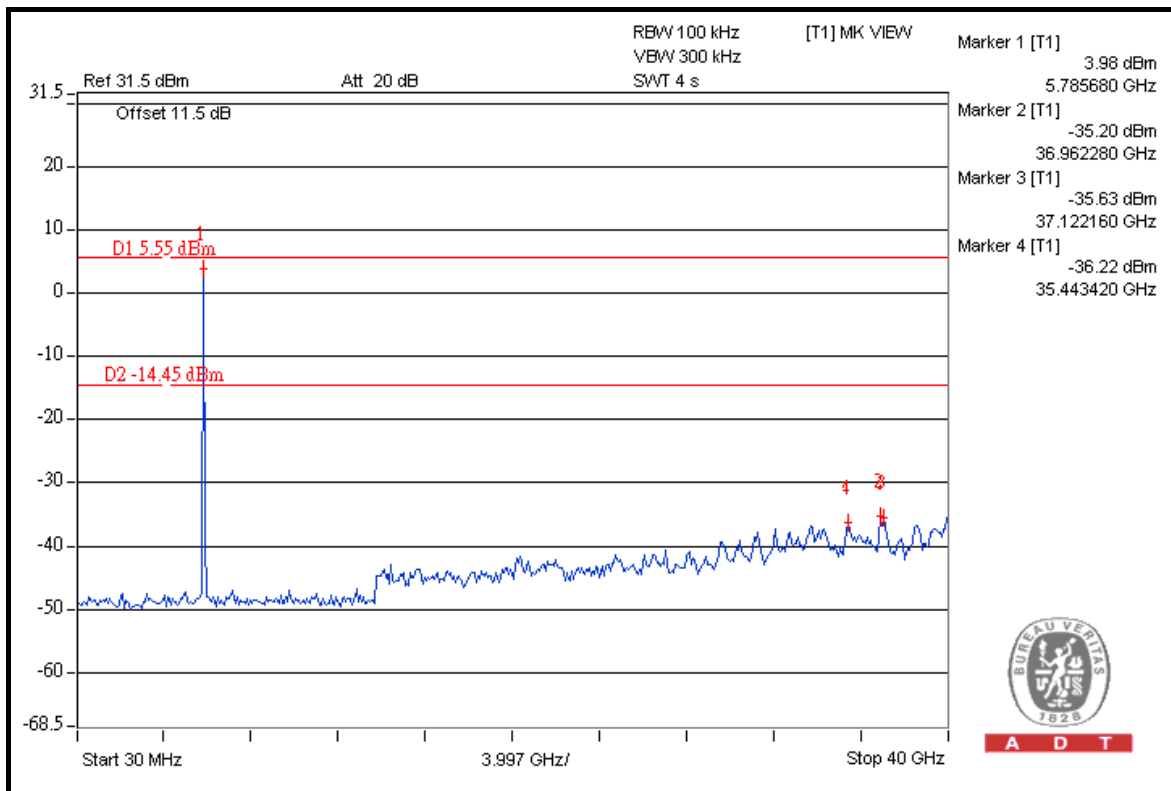
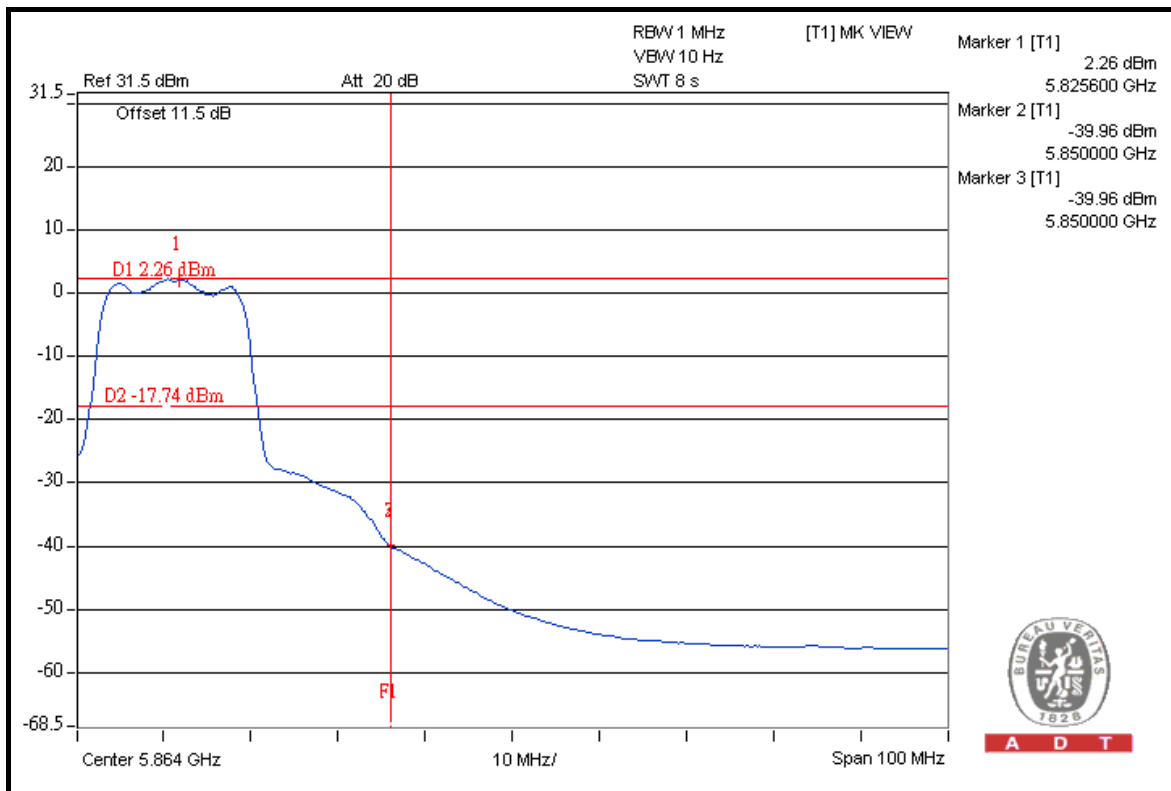



A D T

802.11n (20MHz)

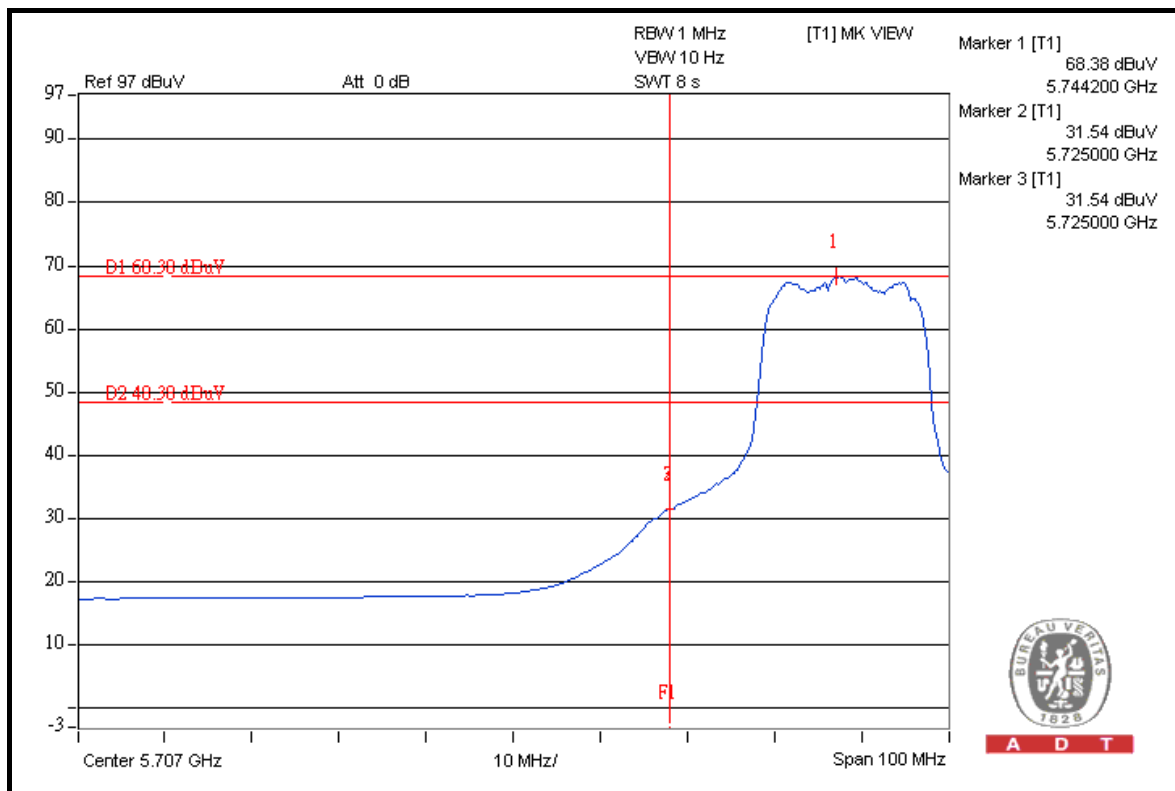
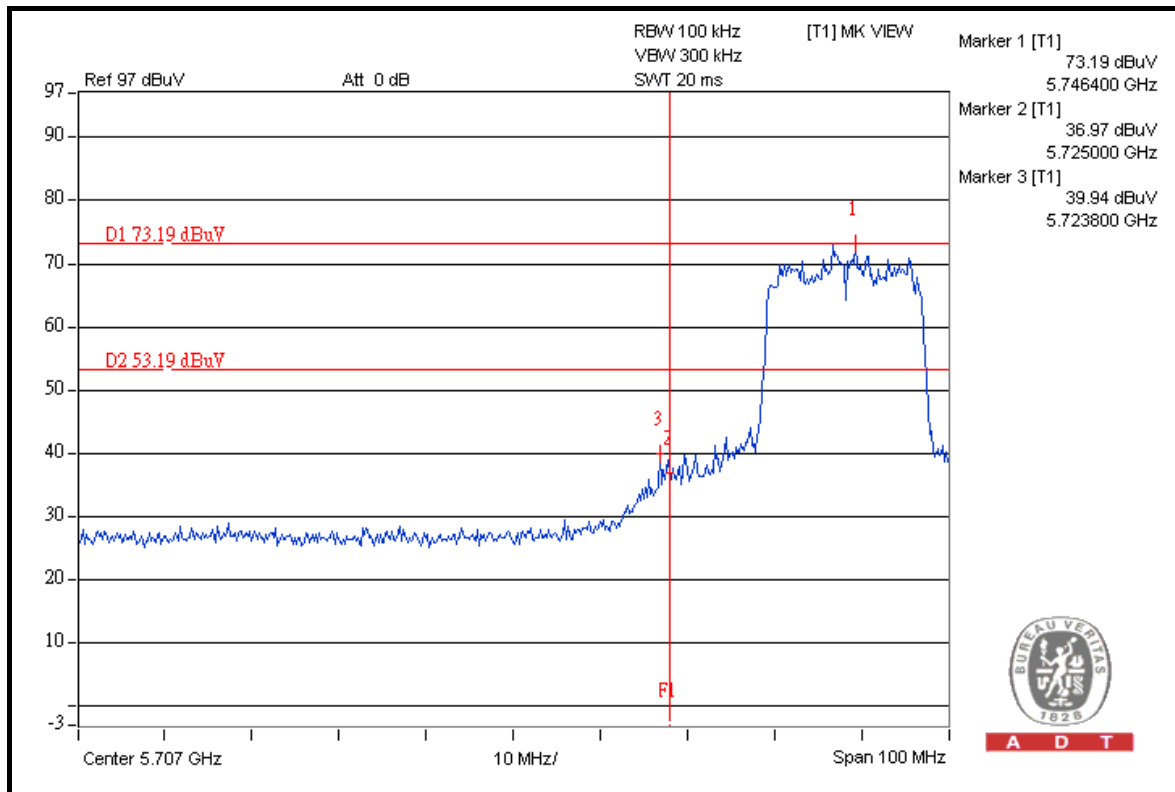



A D T

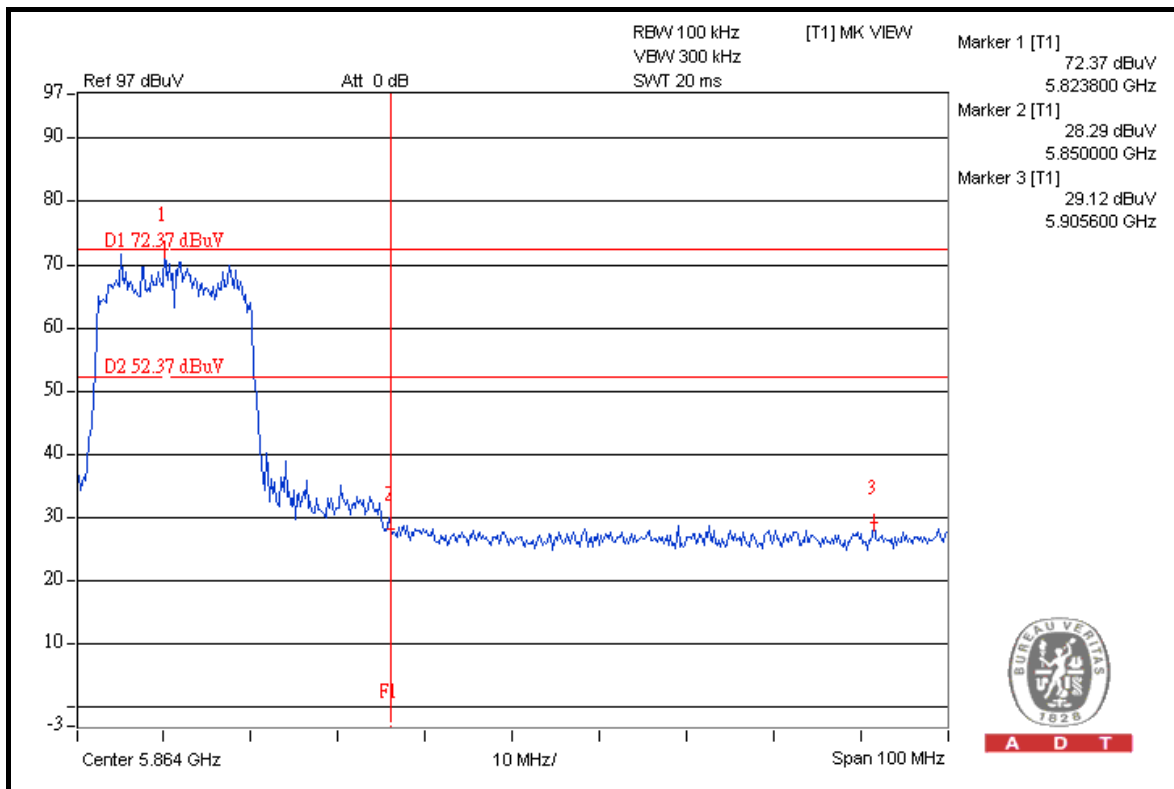
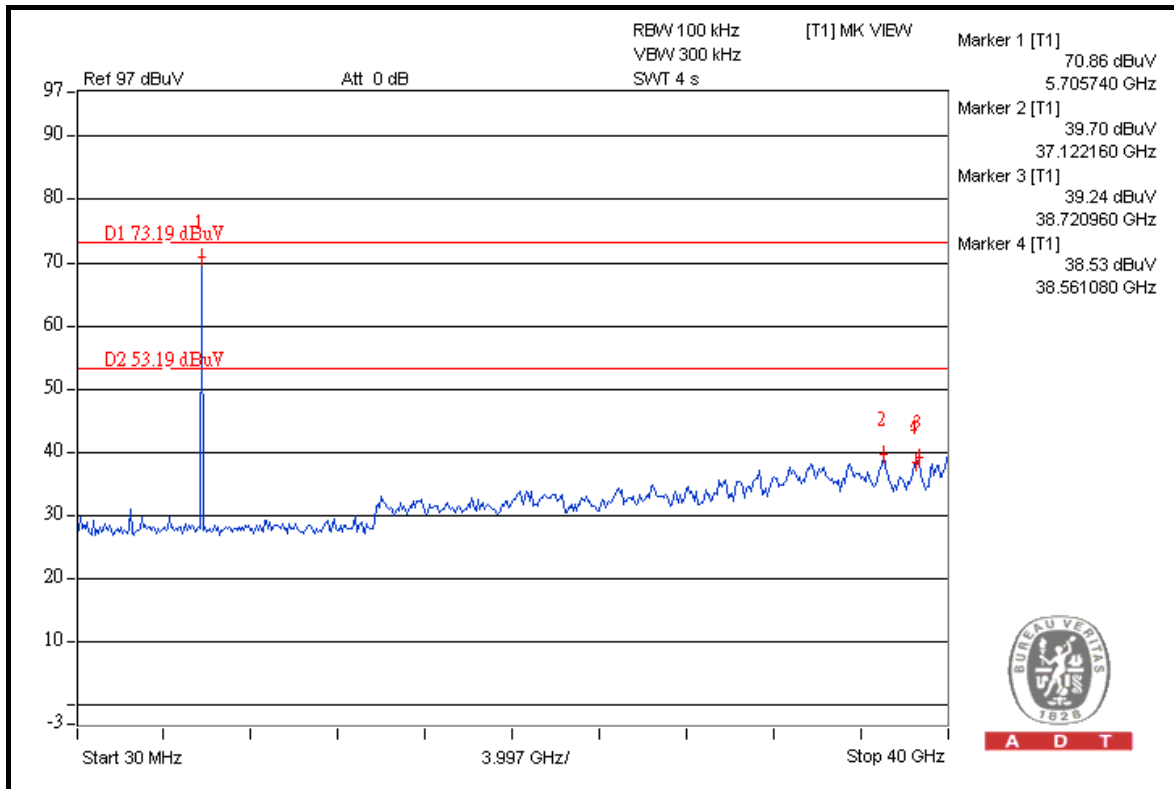



A D T

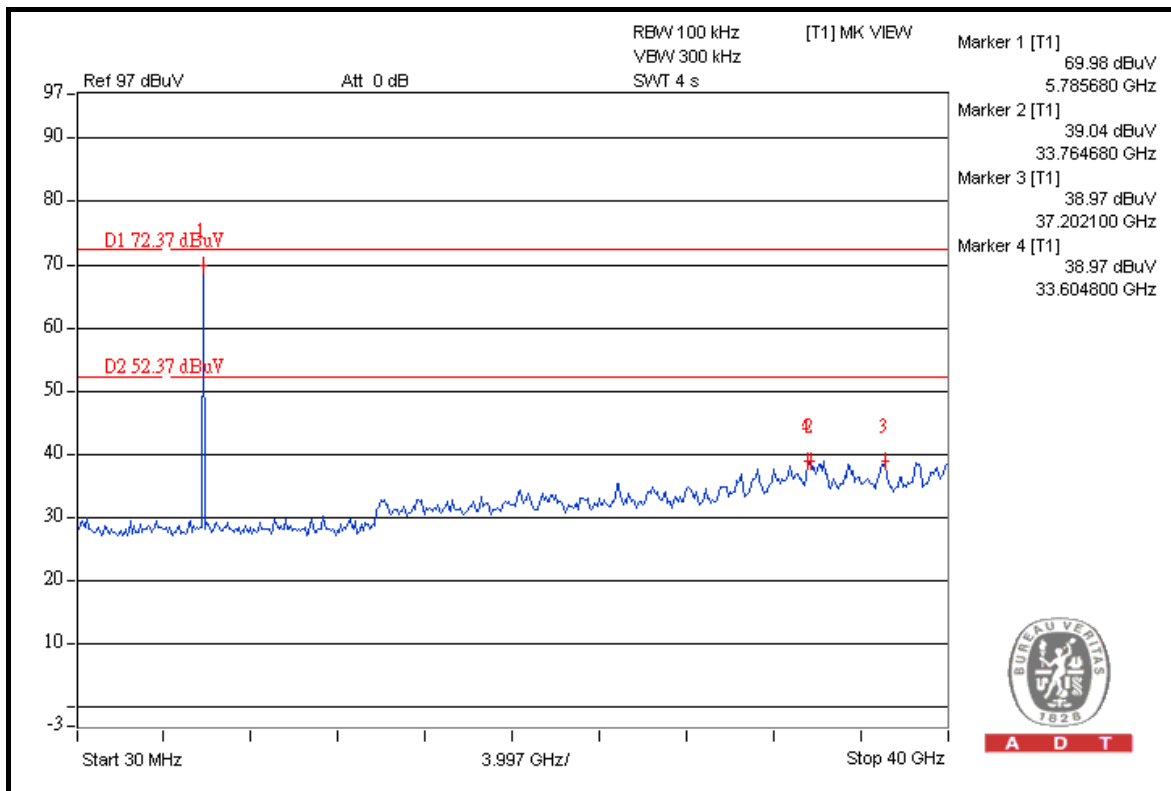
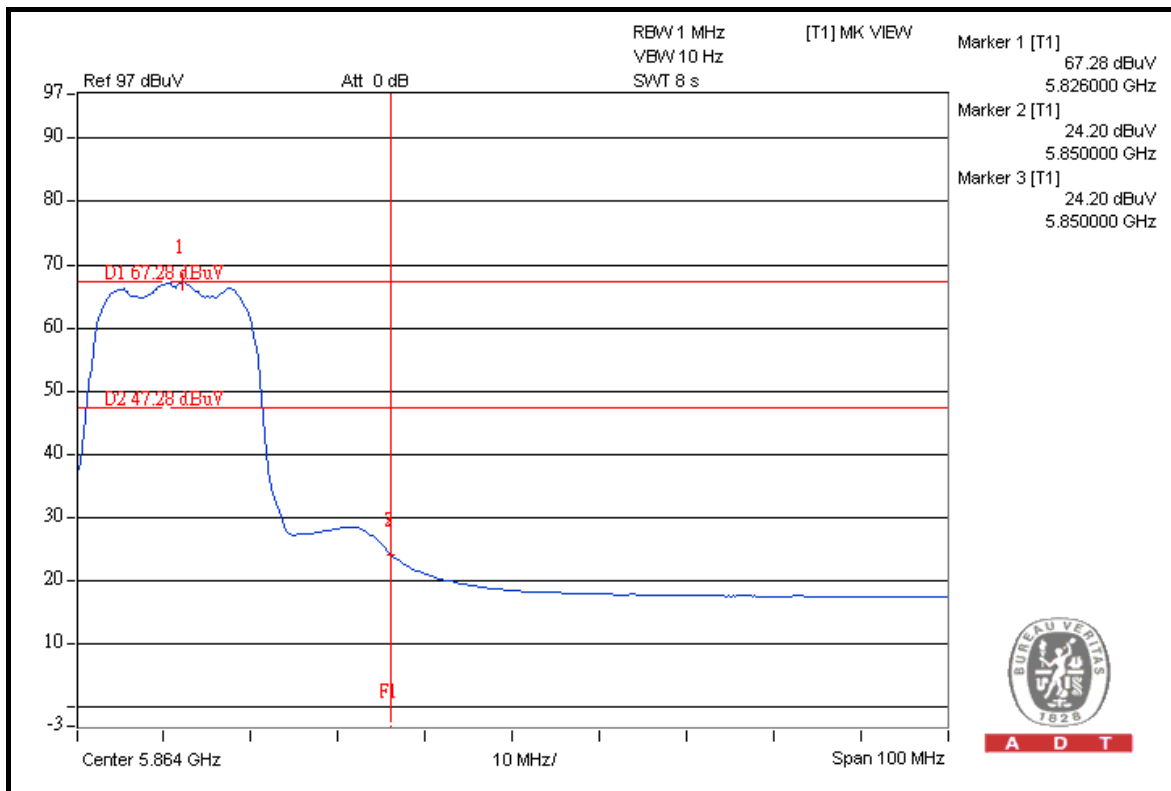



A D T

802.11n (40MHz)

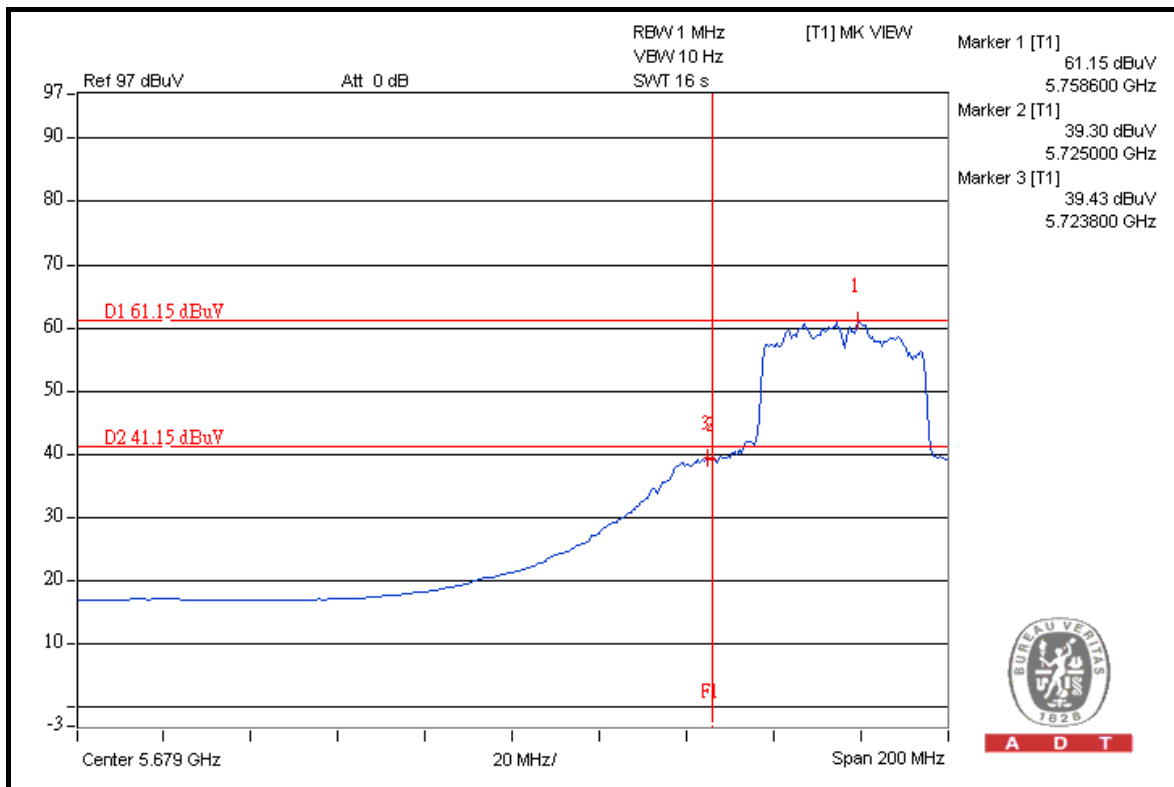
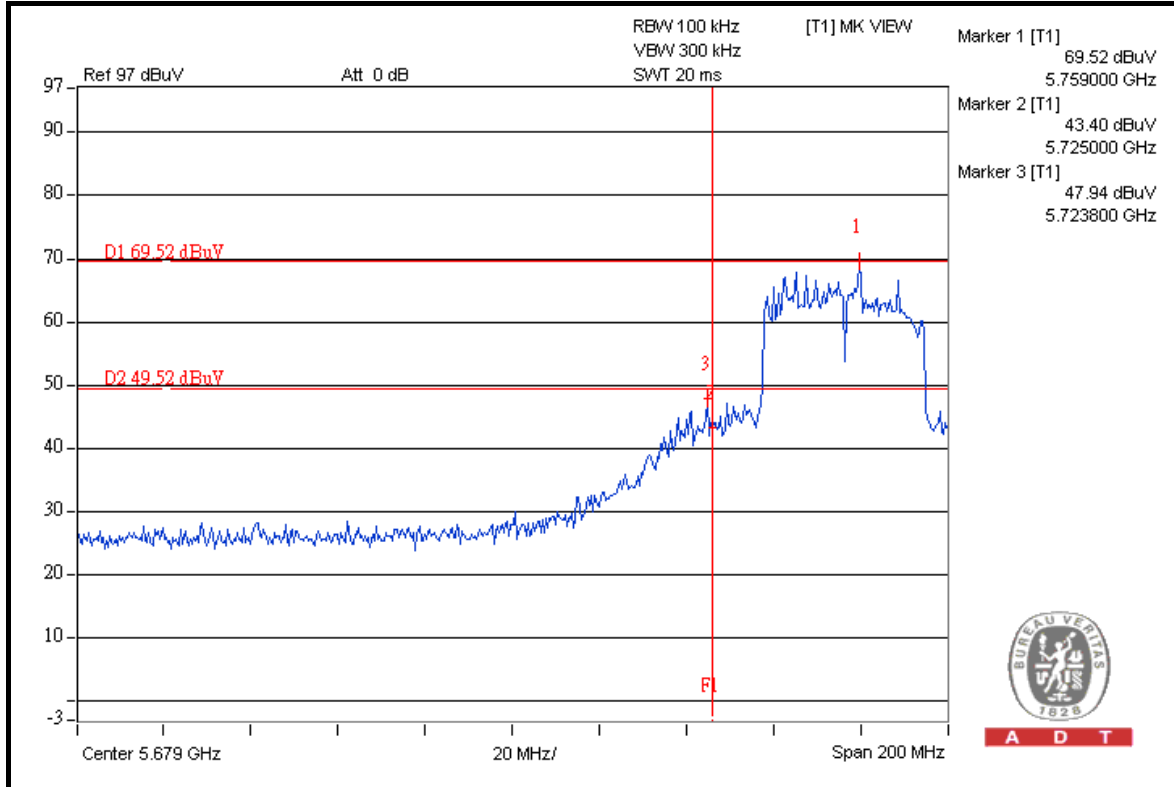



A D T

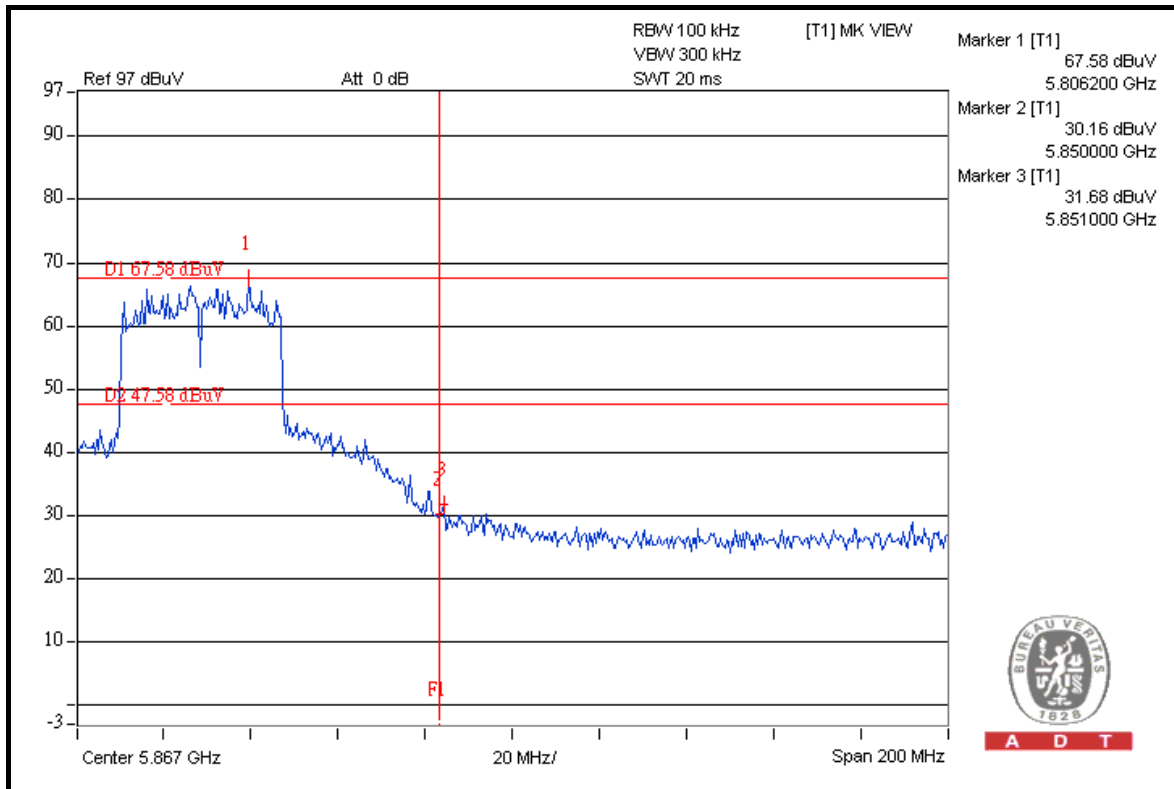
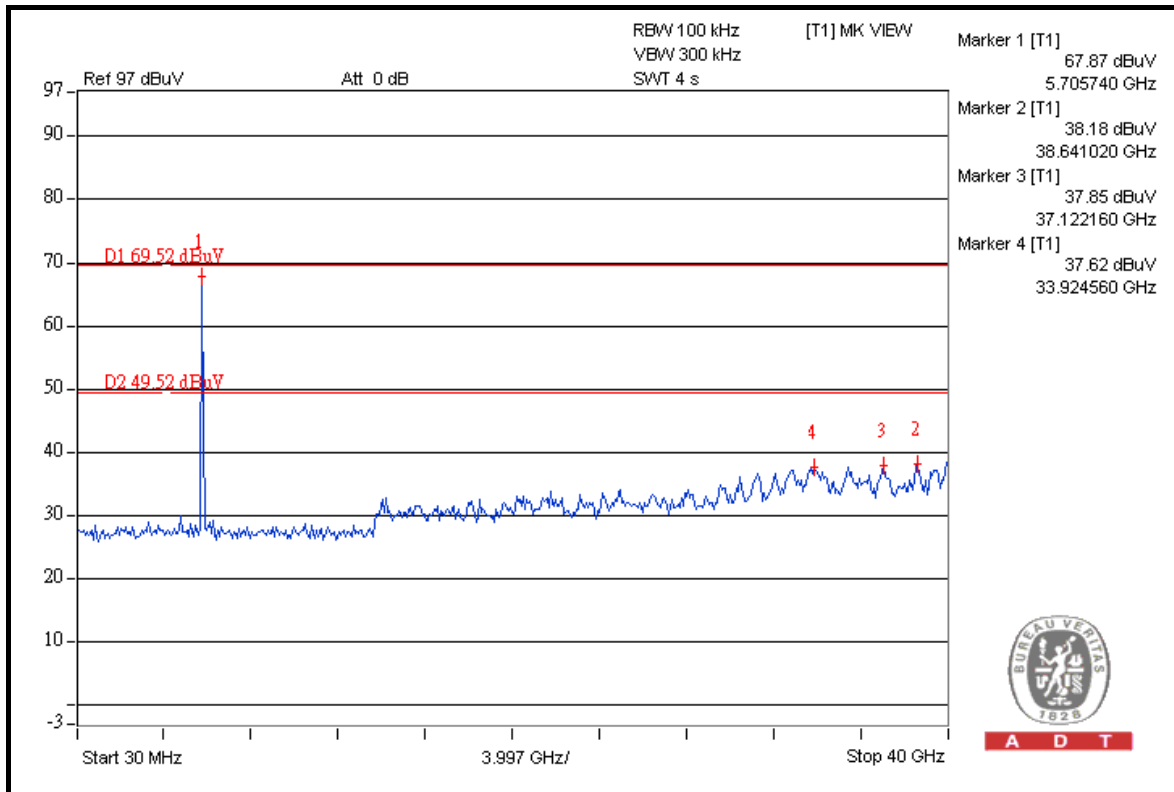



A D T

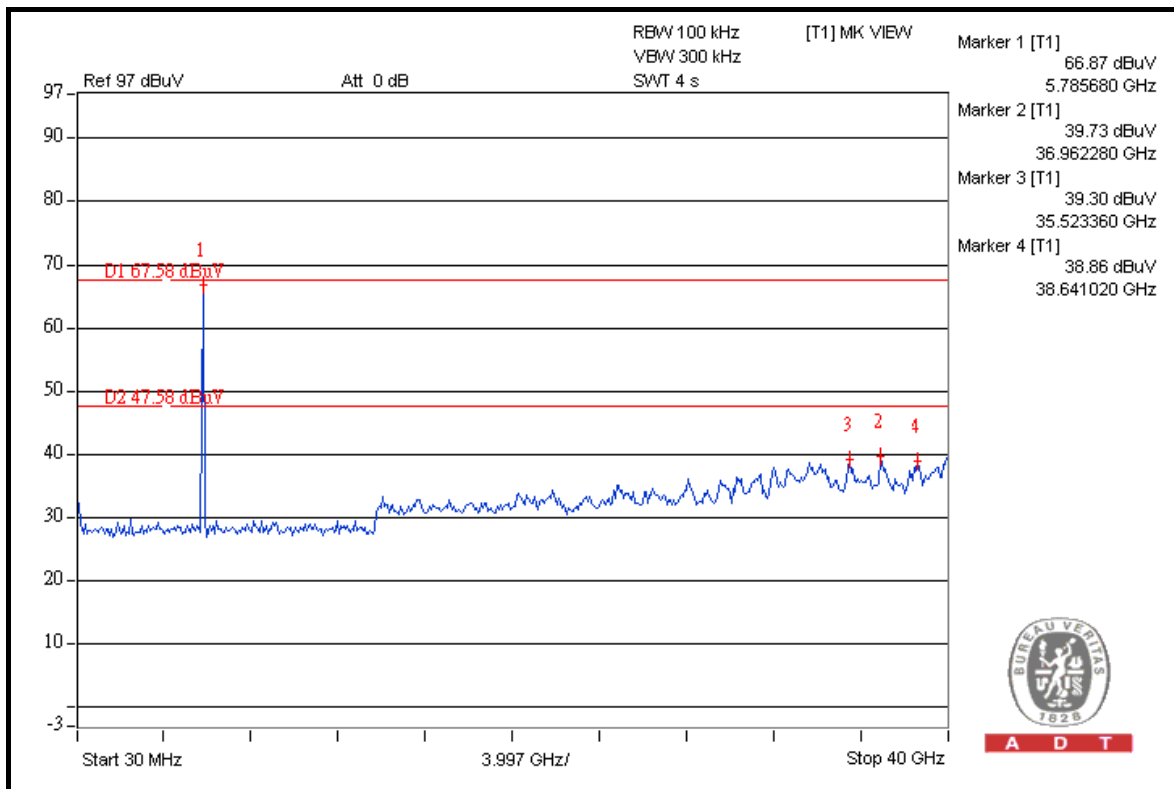
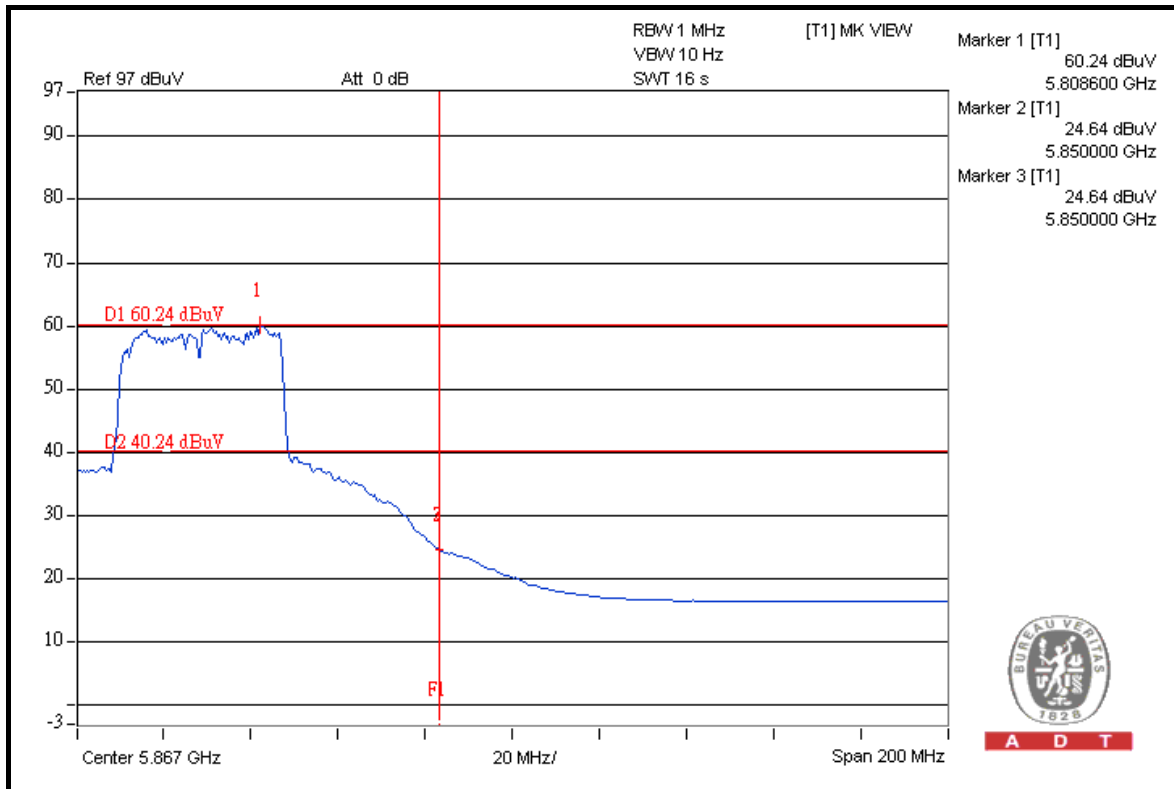



A D T

6. PHOTOGRAPHS OF THE TEST CONFIGURATION

Please refer to the attached file (Test Setup Photo).



A D T

7. INFORMATION ON THE TESTING LABORATORIES

We, Bureau Veritas Consumer Products Services (H.K.) Ltd., Taoyuan Branch, were founded in 1988 to provide our best service in EMC, Radio, Telecom and Safety consultation. Our laboratories are accredited and approved according to ISO/IEC 17025.

Copies of accreditation certificates of our laboratories obtained from approval agencies can be downloaded from our web site:

www.adt.com.tw/index.5/phtml. If you have any comments, please feel free to contact us at the following:

Linko EMC/RF Lab:

Tel: 886-2-26052180

Fax: 886-2-26051924

Hsin Chu EMC/RF Lab:

Tel: 886-3-5935343

Fax: 886-3-5935342

Hwa Ya EMC/RF/Safety Telecom Lab:

Tel: 886-3-3183232

Fax: 886-3-3185050

Web Site: www.adt.com.tw

The address and road map of all our labs can be found in our web site also.



A D T

8. APPENDIX A - MODIFICATIONS RECORDERS FOR ENGINEERING CHANGES TO THE EUT BY THE LAB

No any modifications are made to the EUT by the lab during the test.

---END---