

FCC Test Report

Report No.: RF150828E07-1

FCC ID: W59XAP1510

Test Model: XAP-1510

Series Model: XWS-2510

Received Date: Aug. 28, 2015

Test Date: Sep. 09 to 12, 2015

Issued Date: Sep. 23, 2015

Applicant: Luxul Wireless

Address: 14203 Minuteman Dr Suite 201 Draper UT 84020 USA

Issued By: Bureau Veritas Consumer Products Services (H.K.) Ltd., Taoyuan Branch
Hsin Chu Laboratory

Lab Address: No. 81-1, Lu Liao Keng, 9th Ling, Wu Lung Tsuen, Chiung Lin Hsiang, Hsin
Chu Hsien 307, Taiwan R.O.C.

Test Location (1): No. 81-1, Lu Liao Keng, 9th Ling, Wu Lung Tsuen, Chiung Lin Hsiang, Hsin
Chu Hsien 307, Taiwan R.O.C.

Test Location (2): No. 49, Ln. 206, Wende Rd., Shangshan Tsuen, Chiung Lin Hsiang, Hsin
Chu Hsien 307, Taiwan R.O.C.

Test Location (3): E-2, No.1, Li Hsin 1st Road, Hsinchu Science Park, Hsinchu City 300,
Taiwan R.O.C.



This report is for your exclusive use. Any copying or replication of this report to or for any other person or entity, or use of our name or trademark, is permitted only with our prior written permission. This report sets forth our findings solely with respect to the test samples identified herein. The results set forth in this report are not indicative or representative of the quality or characteristics of the lot from which a test sample was taken or any similar or identical product unless specifically and expressly noted. Our report includes all of the tests requested by you and the results thereof based upon the information that you provided to us. You have 60 days from date of issuance of this report to notify us of any material error or omission caused by our negligence, provided, however, that such notice shall be in writing and shall specifically address the issue you wish to raise. A failure to raise such issue within the prescribed time shall constitute your unqualified acceptance of the completeness of this report, the tests conducted and the correctness of the report contents. Unless specific mention, the uncertainty of measurement has been explicitly taken into account to declare the compliance or non-compliance to the specification. The report must not be used by the client to claim product certification, approval, or endorsement by TAF or any government agencies.

Table of Contents

Release Control Record	4
1 Certificate of Conformity	5
2 Summary of Test Results	6
2.1 Measurement Uncertainty	6
2.2 Modification Record	6
3 General Information	7
3.1 General Description of EUT	7
3.2 Description of Test Modes	10
3.2.1 Test Mode Applicability and Tested Channel Detail.....	11
3.3 Duty Cycle of Test Signal	14
3.4 Description of Support Units	15
3.4.1 Configuration of System under Test	15
3.5 General Description of Applied Standard.....	16
4 Test Types and Results	17
4.1 Radiated Emission and Bandedge Measurement.....	17
4.1.1 Limits of Radiated Emission and Bandedge Measurement	17
4.1.2 Test Instruments	18
4.1.3 Test Procedure	20
4.1.4 Deviation from Test Standard	20
4.1.5 Test Setup.....	21
4.1.6 EUT Operating Condition	21
4.1.7 Test Results	22
4.2 Conducted Emission Measurement	53
4.2.1 Limits of Conducted Emission Measurement	53
4.2.2 Test Instruments	53
4.2.3 Test Procedure	54
4.2.4 Deviation from Test Standard	54
4.2.5 Test Setup.....	54
4.2.6 EUT Operating Condition	54
4.2.7 Test Results	55
4.3 Transmit Power Measurement	57
4.3.1 Limits of Transmit Power Measurement	57
4.3.2 Test Setup.....	57
4.3.3 Test Instruments	57
4.3.4 Test Procedure	58
4.3.5 Deviation from Test Standard	58
4.3.6 EUT Operating Condition	58
4.3.7 Test Result.....	59
4.4 Peak Power Spectral Density Measurement	61
4.4.1 Limits of Peak Power Spectral Density Measurement	61
4.4.2 Test Setup.....	61
4.4.3 Test Instruments	61
4.4.4 Test Procedure	62
4.4.5 Deviation from Test Standard	62
4.4.6 EUT Operating Condition	62
4.4.7 Test Results	63
4.5 Frequency Stability Measurement	68
4.5.1 Limits of Frequency Stability Measurement	68
4.5.2 Test Setup.....	68
4.5.3 Test Instruments	68
4.5.4 Test Procedure	68
4.5.5 Deviation from Test Standard	68
4.5.6 EUT Operating Condition	68



4.5.7 Test Results	69
4.6 6dB Bandwidth Measurement	70
4.6.1 Limits of 6dB Bandwidth Measurement	70
4.6.2 Test Setup	70
4.6.3 Test Instruments	70
4.6.4 Test Procedure	70
4.6.5 Deviation from Test Standard	70
4.6.6 EUT Operating Condition	70
4.6.7 Test Results	71
5 Pictures of Test Arrangements	73
Appendix – Information on the Testing Laboratories	74



A D T

Release Control Record

Issue No.	Description	Date Issued
RF150828E07-1	Original release.	Sep. 23, 2015



1 Certificate of Conformity

Product: High Power AC1900 Dual-Band Wireless AP
Brand: LUXUL
Test Model: XAP-1510
Series Model: XWS-2510
Sample Status: ENGINEERING SAMPLE
Applicant: Luxul Wireless
Test Date: Sep. 09 to 12, 2015
Standard: 47 CFR FCC Part 15, Subpart E (Section 15.407)
ANSI C63.10: 2013

The above equipment has been tested by **Bureau Veritas Consumer Products Services (H.K.) Ltd., Taoyuan Branch**, and found compliance with the requirement of the above standards. The test record, data evaluation & Equipment Under Test (EUT) configurations represented herein are true and accurate accounts of the measurements of the sample's EMC characteristics under the conditions specified in this report.

Prepared by :  , **Date:** Sep. 23, 2015
Lori Chung / Specialist

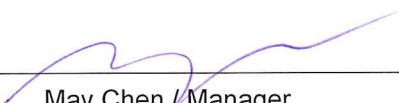
Approved by :  , **Date:** Sep. 23, 2015
May Chen / Manager

2 Summary of Test Results

47 CFR FCC Part 15, Subpart E (SECTION 15.407)			
FCC Clause	Test Item	Result	Remarks
15.407(b)(6)	AC Power Conducted Emissions	PASS	Meet the requirement of limit. Minimum passing margin is -2.32dB at 0.30234MHz.
15.407(b)(1/2/3/4/6)	Radiated Emissions & Band Edge Measurement	PASS	Meet the requirement of limit. Minimum passing margin is -0.1dB at 17475.00MHz, 5150.00MHz & 5715.00MHz.
15.407(a)(1/2/3)	Max Average Transmit Power	PASS	Meet the requirement of limit.
15.407(a)(1/2/3)	Peak Power Spectral Density	PASS	Meet the requirement of limit.
15.407(e)	6dB bandwidth	PASS	Meet the requirement of limit. (U-NII-3 Band only)
15.407(g)	Frequency Stability	PASS	Meet the requirement of limit.
15.203	Antenna Requirement	PASS	Antenna connector is i-pex(MHF) not a standard connector.

NOTE: 1. The EUT was operating in 2.4 ~ 2.4835GHz, 5.15~5.25GHz and 5.725~5.85GHz frequencies band. This report was recorded the RF parameters including 5.15~5.25GHz and 5.725~5.85GHz. For the 2.4 ~ 2.4835GHz RF parameters was recorded in another test report.

2.1 Measurement Uncertainty

Where relevant, the following measurement uncertainty levels have been estimated for tests performed on the EUT as specified in CISPR 16-4-2:

Measurement	Frequency	Expanded Uncertainty (k=2) (±)
Conducted Emissions at mains ports	150kHz ~ 30MHz	2.86 dB
Radiated Emissions up to 1 GHz	30MHz ~ 1GHz	5.43 dB
Radiated Emissions above 1 GHz	1GHz ~ 6GHz	3.65 dB
	6GHz ~ 18GHz	3.88 dB
	18GHz ~ 40GHz	4.11 dB

2.2 Modification Record

There were no modifications required for compliance.

3 General Information

3.1 General Description of EUT

Product	High Power AC1900 Dual-Band Wireless AP
Brand	LUXUL
Test Model	XAP-1510
Series Model	XWS-2510
Status of EUT	ENGINEERING SAMPLE
Power Supply Rating	48Vdc from POE
Modulation Type	CCK, DQPSK, DBPSK for DSSS 64QAM, 16QAM, QPSK, BPSK for OFDM 256QAM for OFDM in 11ac mode and VHT (20/40) mode in 2.4GHz
Modulation Technology	DSSS, OFDM
Transfer Rate	802.11b: up to 11Mbps 802.11a: up to 54Mbps 802.11n: up to 450Mbps 802.11ac: up to 1300Mbps
Operating Frequency	For 15.247: 2.412 ~ 2.462GHz For 15.407: 5.18 ~ 5.24GHz, 5.745 ~ 5.825GHz
Number of Channel	For 2.4GHz: 11 for 802.11b, 802.11g, 802.11n (HT20), VHT20 7 for 802.11n (HT40), VHT40 For 5GHz: 9 for 802.11a, 802.11n (HT20), 802.11ac (VHT20) 4 for 802.11n (HT40), 802.11ac (VHT40) 2 for 802.11ac (VHT80)
Output Power	For 2.4GHz: CDD Mode: 802.11b: 605.624mW 802.11g: 790.746mW VHT20: 751.503mW VHT40: 229.57mW Beamforming Mode: VHT20: 547.733mW VHT40: 191.375mW For 5GHz: CDD Mode: 802.11a: 447.865mW 802.11ac (VHT20): 392.124W 802.11ac (VHT40): 611.716mW 802.11ac (VHT80): 195.614mW Beamforming Mode: 802.11ac (VHT20): 378.038mW 802.11ac (VHT40): 388.373mW 802.11ac (VHT80): 130.735mW
Antenna Type	Refer to Note
Antenna Connector	Refer to Note
Accessory Device	POE x 1
Data Cable Supplied	RJ45 cable (Unshielded, 0.9m) x 1

Note:

1. The EUT has two model names, which are identical to each other in all aspects except for the following table:

Brand	Model No.	Difference
LUXUL	XAP-1510	With one XAP-1510 in gift box.
	XWS-2510	With two XAP-1510 in gift box.

From the above models, model: XAP-1510 was selected as representative model for the test and its data was recorded in this report.

2. 2.4GHz and 5GHz technology can transmit at same time.
 3. The antennas provided to the EUT, please refer to the following table:

Transmitter Circuit	Brand	Model	Antenna Gain (dBi)	Frequency range (GHz to GHz)	Antenna Type	Connector Type
Chain (0)	NA	29020222	2.7	2.4-2.4835	PIFA	i-pex(MHF)
			5.2	5.15-5.85		
Chain (1)	NA	29020223	2.7	2.4-2.4835	PIFA	i-pex(MHF)
			5.2	5.15-5.85		
Chain (2)	NA	29020224	2.7	2.4-2.4835	PIFA	i-pex(MHF)
			5.2	5.15-5.85		

4. The EUT must be supplied with an POE as following table:

Brand Name	Model No.	Spec.
Great power	GRT-480125A	Input: 100-240V, 50/60Hz Output: 48V, 1250mA

5. The EUT incorporates a MIMO function.

2.4GHz Band			
MODULATION MODE	DATA RATE (MCS)	TX & RX CONFIGURATION	
802.11b	1 ~ 11Mbps	3TX	3RX
802.11g	6 ~ 54Mbps	3TX	3RX
802.11n (HT20)	MCS 0~7	3TX	3RX
	MCS 8~15	3TX	3RX
	MCS 16~23	3TX	3RX
802.11n (HT40)	MCS 0~7	3TX	3RX
	MCS 8~15	3TX	3RX
	MCS 16~23	3TX	3RX
VHT20	MCS 0~8, Nss=1	3TX	3RX
	MCS 0~8, Nss=2	3TX	3RX
	MCS 0~9, Nss=3	3TX	3RX
VHT40	MCS 0~9, Nss=1	3TX	3RX
	MCS 0~9, Nss=2	3TX	3RX
	MCS 0~9, Nss=3	3TX	3RX
5GHz Band			
MODULATION MODE	DATA RATE (MCS)	TX & RX CONFIGURATION	
802.11a	6 ~ 54Mbps	3TX	3RX
802.11n (HT20)	MCS 0~7	3TX	3RX
	MCS 8~15	3TX	3RX
	MCS 16~23	3TX	3RX
802.11n (HT40)	MCS 0~7	3TX	3RX
	MCS 8~15	3TX	3RX
	MCS 16~23	3TX	3RX
802.11ac (VHT20)	MCS 0~8, Nss=1	3TX	3RX
	MCS 0~8, Nss=2	3TX	3RX
	MCS 0~9, Nss=3	3TX	3RX
802.11ac (VHT40)	MCS 0~9, Nss=1	3TX	3RX
	MCS 0~9, Nss=2	3TX	3RX
	MCS 0~9, Nss=3	3TX	3RX
802.11ac (VHT80)	MCS 0~9, Nss=1	3TX	3RX
	MCS 0~9, Nss=2	3TX	3RX
	MCS 0~9, Nss=3	3TX	3RX

Note:

1. The modulation and bandwidth are similar for 802.11n mode for 20MHz (40MHz) and 802.11ac mode for 20MHz (40MHz), therefore investigated worst case to representative mode in test report. (Final test mode refer section 3.2.1)

2. All of modulation mode support beamforming function except (802.11b/g/a) modulation mode.

6. The above EUT information is declared by manufacturer and for more detailed features description, please refer to the manufacturer's specifications or user's manual.

3.2 Description of Test Modes

FOR 5180 ~ 5240MHz

4 channels are provided for 802.11a, 802.11n (HT20), 802.11ac (VHT20):

Channel	Frequency	Channel	Frequency
36	5180 MHz	44	5220 MHz
40	5200 MHz	48	5240 MHz

2 channels are provided for 802.11n (HT40), 802.11ac (VHT40):

Channel	Frequency	Channel	Frequency
38	5190 MHz	46	5230 MHz

1 channel is provided for 802.11ac (VHT80):

Channel	Frequency
42	5210MHz

FOR 5745 ~ 5825MHz:

5 channels are provided for 802.11a, 802.11n (HT20), 802.11ac (VHT20):

Channel	Frequency	Channel	Frequency
149	5745MHz	161	5805MHz
153	5765MHz	165	5825MHz
157	5785MHz		

2 channels are provided for 802.11n (HT40), 802.11ac (VHT40):

Channel	Frequency	Channel	Frequency
151	5755MHz	159	5795MHz

1 channel is provided for 802.11ac (VHT80):

Channel	Frequency
155	5775MHz

3.2.1 Test Mode Applicability and Tested Channel Detail

EUT CONFIGURE MODE	APPLICABLE TO				DESCRIPTION
	RE≥1G	RE<1G	PLC	APCM	
-	√	√	√	√	-

Where **RE≥1G**: Radiated Emission above 1GHz **RE<1G**: Radiated Emission below 1GHz
PLC: Power Line Conducted Emission **APCM**: Antenna Port Conducted Measurement

NOTE:

1. The EUT had been pre-tested on the positioned of each 2 axis. The worst case was found when positioned on **Y-plane**.

Radiated Emission Test (Above 1GHz):

- Pre-Scan has been conducted to determine the worst-case mode from all possible combinations between available modulations, data rates and antenna ports (if EUT with antenna diversity architecture).
- Following channel(s) was (were) selected for the final test as listed below.

CDD Mode						
MODE	FREQ. BAND (MHz)	AVAILABLE CHANNEL	TESTED CHANNEL	MODULATION TECHNOLOGY	MODULATION TYPE	DATA RATE (Mbps)
802.11a	5180-5240	36 to 48	36, 40, 48	OFDM	BPSK	6
802.11ac (VHT20)		36 to 48	36, 40, 48	OFDM	BPSK	6.5
802.11ac (VHT40)		38 to 46	38, 46	OFDM	BPSK	13.5
802.11ac (VHT80)		42	42	OFDM	BPSK	29.3
802.11a	5745-5825	149 to 165	149, 157, 165	OFDM	BPSK	6
802.11ac (VHT20)		149 to 165	149, 157, 165	OFDM	BPSK	6.5
802.11ac (VHT40)		151 to 159	151, 159	OFDM	BPSK	13.5
802.11ac (VHT80)		155	155	OFDM	BPSK	29.3
Beamforming Mode						
MODE	FREQ. BAND (MHz)	AVAILABLE CHANNEL	TESTED CHANNEL	MODULATION TECHNOLOGY	MODULATION TYPE	DATA RATE (Mbps)
802.11ac (VHT20)	5180-5240	36 to 48	36, 40, 48	OFDM	BPSK	6.5
802.11ac (VHT40)		38 to 46	38, 46	OFDM	BPSK	13.5
802.11ac (VHT80)		42	42	OFDM	BPSK	29.3
802.11ac (VHT20)	5745-5825	149 to 165	149, 157, 165	OFDM	BPSK	6.5
802.11ac (VHT40)		151 to 159	151, 159	OFDM	BPSK	13.5
802.11ac (VHT80)		155	155	OFDM	BPSK	29.3

Radiated Emission Test (Below 1GHz):

- Pre-Scan has been conducted to determine the worst-case mode from all possible combinations between available modulations, data rates and antenna ports (if EUT with antenna diversity architecture).
- Following channel(s) was (were) selected for the final test as listed below.

CDD Mode						
MODE	FREQ. BAND (MHz)	AVAILABLE CHANNEL	TESTED CHANNEL	MODULATION TECHNOLOGY	MODULATION TYPE	DATA RATE (Mbps)
802.11ac (VHT40)	5180-5240 5745-5825	38 to 46 151 to 159	159	OFDM	BPSK	13.5

Power Line Conducted Emission Test:

- Pre-Scan has been conducted to determine the worst-case mode from all possible combinations between available modulations, data rates and antenna ports (if EUT with antenna diversity architecture).
- Following channel(s) was (were) selected for the final test as listed below.

CDD Mode						
MODE	FREQ. BAND (MHz)	AVAILABLE CHANNEL	TESTED CHANNEL	MODULATION TECHNOLOGY	MODULATION TYPE	DATA RATE (Mbps)
802.11ac (VHT40)	5180-5240	38 to 46	159	OFDM	BPSK	13.5
	5745-5825	151 to 159				

Antenna Port Conducted Measurement:

- This item includes all test value of each mode, but only includes spectrum plot of worst value of each mode.
- Pre-Scan has been conducted to determine the worst-case mode from all possible combinations between available modulations, data rates and antenna ports (if EUT with antenna diversity architecture).
- Following channel(s) was (were) selected for the final test as listed below.

CDD Mode						
Transmit Power Measurement / Peak Power Spectral Density Measurement / 6dB Bandwidth Measurement						
MODE	FREQ. BAND (MHz)	AVAILABLE CHANNEL	TESTED CHANNEL	MODULATION TECHNOLOGY	MODULATION TYPE	DATA RATE (Mbps)
802.11a	5180-5240	36 to 48	36, 40, 48	OFDM	BPSK	6
802.11ac (VHT20)		36 to 48	36, 40, 48	OFDM	BPSK	6.5
802.11ac (VHT40)		38 to 46	38, 46	OFDM	BPSK	13.5
802.11ac (VHT80)		42	42	OFDM	BPSK	29.3
802.11a	5745-5825	149 to 165	149, 157, 165	OFDM	BPSK	6
802.11ac (VHT20)		149 to 165	149, 157, 165	OFDM	BPSK	6.5
802.11ac (VHT40)		151 to 159	151, 159	OFDM	BPSK	13.5
802.11ac (VHT80)		155	155	OFDM	BPSK	29.3
Beamforming Mode						
Transmit Power Measurement						
MODE	FREQ. BAND (MHz)	AVAILABLE CHANNEL	TESTED CHANNEL	MODULATION TECHNOLOGY	MODULATION TYPE	DATA RATE (Mbps)
802.11ac (VHT20)	5180-5240	36 to 48	36, 40, 48	OFDM	BPSK	6.5
802.11ac (VHT40)		38 to 46	38, 46	OFDM	BPSK	13.5
802.11ac (VHT80)		42	42	OFDM	BPSK	29.3
802.11ac (VHT20)	5745-5825	149 to 165	149, 157, 165	OFDM	BPSK	6.5
802.11ac (VHT40)		151 to 159	151, 159	OFDM	BPSK	13.5
802.11ac (VHT80)		155	155	OFDM	BPSK	29.3



Test Condition:

APPLICABLE TO	ENVIRONMENTAL CONDITIONS	INPUT POWER	TESTED BY
RE≥1G	24deg. C, 67%RH	120Vac, 60Hz	Andy Ho
RE<1G	23deg. C, 69%RH	120Vac, 60Hz	Robert Cheng
PLC	26deg. C, 62%RH	120Vac, 60Hz	Timmy Hu
APCM	25deg. C, 60%RH	120Vac, 60Hz	Anderson Chen

3.3 Duty Cycle of Test Signal

If duty cycle of test signal is $\geq 98\%$, duty factor is not required.

If duty cycle of test signal is $< 98\%$, duty factor shall be considered.

802.11a: Duty cycle = $2.062 \text{ ms} / 2.09 \text{ ms} = 0.987$

802.11ac (VHT20): Duty cycle = $1.911 \text{ ms} / 1.937 \text{ ms} = 0.987$

802.11ac (VHT40): Duty cycle = $0.943 \text{ ms} / 0.962 \text{ ms} = 0.98$

802.11ac (VHT80): Duty cycle = $0.459 \text{ ms} / 0.489 \text{ ms} = 0.939$, Duty factor = $10 * \log(1/0.939) = 0.27$

802.11a

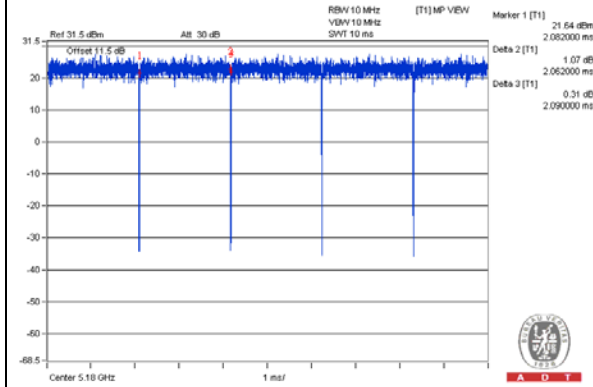

802.11ac (VHT20)

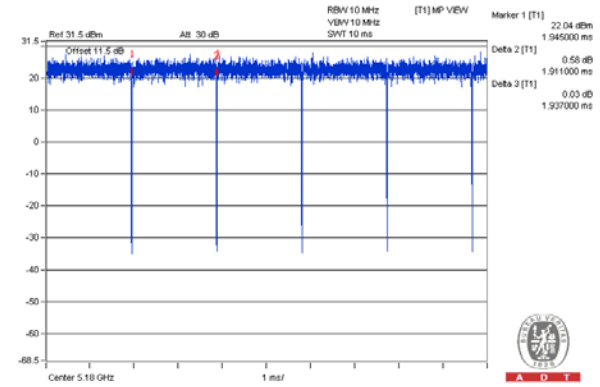

802.11ac (VHT40)

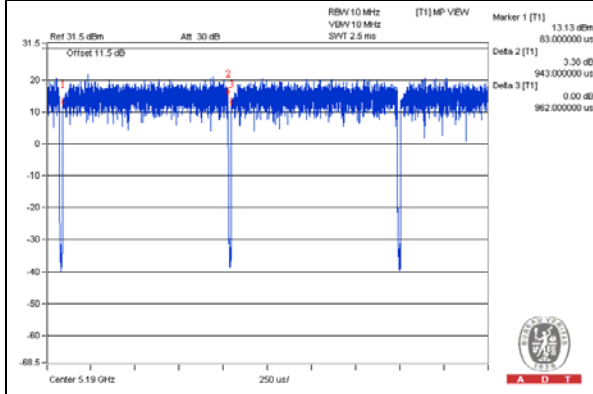

802.11ac (VHT80)

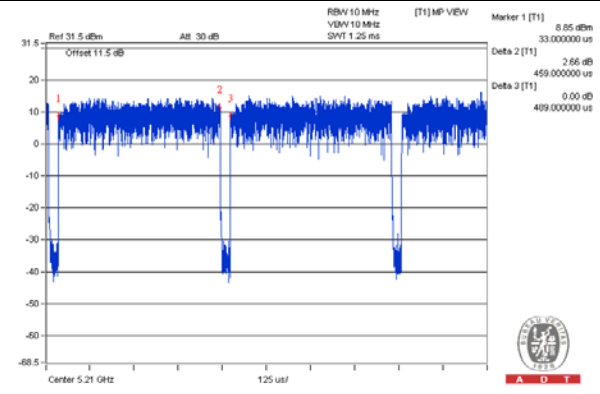

3.4 Description of Support Units

The EUT has been tested as an independent unit together with other necessary accessories or support units. The following support units or accessories were used to form a representative test configuration during the tests.

ID	Product	Brand	Model No.	Serial No.	FCC ID	Remarks
A.	Notebook Computer	DELL	E5430	HYV4VY1	FCC DoC	Provided by Lab
B.	HUB	ZyXEL	ES-116P	S060H02000215	FCC DoC	Provided by Lab

Note:

- All power cords of the above support units are non-shielded (1.8m).

ID	Descriptions	Qty.	Length (m)	Shielding (Yes/No)	Cores (Qty.)	Remarks
1.	RJ45	1	0.9	No	0	Supplied by Client
2.	RJ45	1	10	No	0	Provided by Lab
3.	RJ45	1	10	No	0	Provided by Lab
4.	AC	1	1.8	No	0	Supplied by Client

3.4.1 Configuration of System under Test

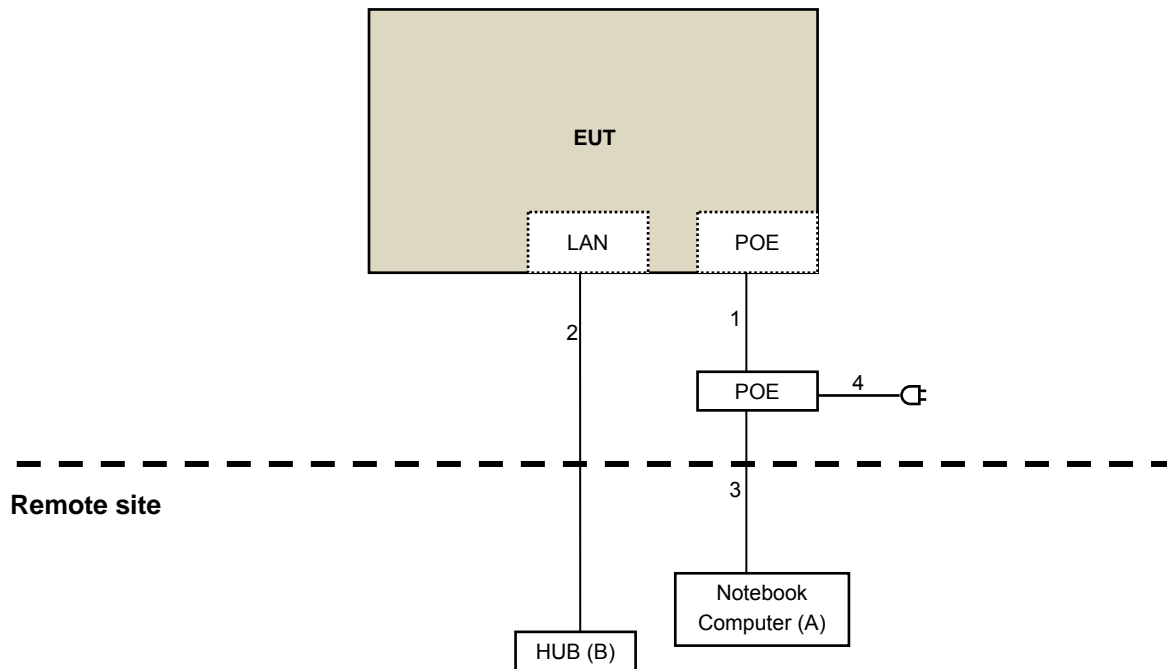

3.5 General Description of Applied Standard

The EUT is a RF Product. According to the specifications of the manufacturer, it must comply with the requirements of the following standards:

FCC Part 15, Subpart E (15.407)
789033 D02 General UNII Test Procedure New Rules v01
662911 D01 Multiple Transmitter Output v02r01
ANSI C63.10-2013

All test items have been performed and recorded as per the above standards.

NOTE: The EUT has been verified to comply with the requirements of FCC Part 15, Subpart B, Class B (DoC). The test report has been issued separately.

4 Test Types and Results

4.1 Radiated Emission and Bandedge Measurement

4.1.1 Limits of Radiated Emission and Bandedge Measurement

Radiated emissions which fall in the restricted bands must comply with the radiated emission limits specified as below table.

Frequencies (MHz)	Field Strength (microvolts/meter)	Measurement Distance (meters)
0.009 ~ 0.490	2400/F(kHz)	300
0.490 ~ 1.705	24000/F(kHz)	30
1.705 ~ 30.0	30	30
30 ~ 88	100	3
88 ~ 216	150	3
216 ~ 960	200	3
Above 960	500	3

NOTE:

1. The lower limit shall apply at the transition frequencies.
2. Emission level (dBuV/m) = 20 log Emission level (uV/m).
3. For frequencies above 1000MHz, the field strength limits are based on average detector, however, the peak field strength of any emission shall not exceed the maximum permitted average limits, specified above by more than 20dB under any condition of modulation.

LIMITS OF UNWANTED EMISSION OUT OF THE RESTRICTED BANDS

APPLICABLE TO	LIMIT	
789033 D02 General UNII Test Procedure New Rules v01	FIELD STRENGTH AT 3m	
	PK:74 (dBuV/m)	AV:54 (dBuV/m)
APPLICABLE TO	EIRP LIMIT	EQUIVALENT FIELD STRENGTH AT 3m
15.407(b)(1)	PK:-27 (dBm/MHz)	PK:68.2(dBuV/m)
15.407(b)(2)		
15.407(b)(3)		
15.407(b)(4)	PK:-27 (dBm/MHz) ^{*1} PK:-17 (dBm/MHz) ^{*2}	PK: 68.2(dBuV/m) ^{*1} PK:78.2 (dBuV/m) ^{*2}

NOTE: ^{*1} beyond 10MHz of the band edge ^{*2} within 10 MHz of band edge

The following formula is used to convert the equipment isotropic radiated power (eirp) to field strength:

$$E = \frac{1000000\sqrt{30P}}{3} \mu\text{V/m, where P is the eirp (Watts).}$$

4.1.2 Test Instruments

For below 1GHz:

DESCRIPTION & MANUFACTURER	MODEL NO.	SERIAL NO.	CALIBRATED DATE	CALIBRATED UNTIL
Test Receiver Agilent	N9038A	MY51210202	Dec. 12, 2014	Dec. 11, 2015
Pre-Amplifier Mini-Circuits	ZFL-1000VH2 B	AMP-ZFL-04	Nov. 12, 2014	Nov. 11, 2015
Trilog Broadband Antenna SCHWARZBECK	VULB 9168	9168-361	Feb. 09, 2015	Feb. 08, 2016
RF Cable	8D-FB	CHHCAB-001-1	Oct. 05, 2014	Oct. 04, 2015
		CHHCAB-001-2		
	RF-141	CHHCAB-004	Oct. 05, 2014	Oct. 04, 2015
Software	ADT_Radiated _V8.7.07	NA	NA	NA
Antenna Tower & Turn Table CT	NA	NA	NA	NA

Note:

1. The calibration interval of the above test instruments is 12 months and the calibrations are traceable to NML/ROC and NIST/USA.
2. The test was performed in 966 Chamber No. H.
3. The FCC Site Registration No. is 797305.
4. The CANADA Site Registration No. is IC 7450H-3.
5. Tested Date: Sep. 10, 2015

For other test items:

DESCRIPTION & MANUFACTURER	MODEL NO.	SERIAL NO.	CALIBRATED DATE	CALIBRATED UNTIL
Test Receiver Agilent	N9038A	MY51210105	July 24, 2015	July 23, 2016
Horn_Antenna AISI	AIH.8018	000032009111 0	Feb. 09, 2015	Feb. 08, 2016
Pre-Amplifier Agilent	8449B	3008A02578	June 23, 2015	June 22, 2016
RF Cable	NA	131205 131216 131217 SNMY23684/ 4	Jan. 16, 2015	Jan. 15, 2016
Spectrum Analyzer R&S	FSV40	100964	June 26, 2015	June 25, 2016
Pre-Amplifier SPACEK LABS	SLKKa-48-6	9K16	Dec. 12, 2014	Dec. 11, 2015
Horn_Antenna SCHWARZBECK	BBHA 9170	9170-424	Feb. 05, 2015	Feb. 04, 2016
RF Cable	NA	329751/4 RF104-204	Dec. 11, 2014	Dec. 10, 2015
Software	ADT_Radiated _V8.7.07	NA	NA	NA
Antenna Tower & Turn Table CT	NA	NA	NA	NA
Power Meter Anritsu	ML2495A	1014008	Apr. 28, 2015	Apr. 27, 2016
Power Sensor Anritsu	MA2411B	0917122	Apr. 28, 2015	Apr. 27, 2016
Spectrum Analyzer R&S	FSP 40	100060	May 08, 2015	May 07, 2016
Temperature & Humidity Chamber GIANTFORCE	GTH-150-40-S P-AR	MAA0812-00 8	Jan. 12, 2015	Jan. 11, 2016

Note:

1. The calibration interval of the above test instruments is 12 months and the calibrations are traceable to NML/ROC and NIST/USA.
2. The test was performed in 966 Chamber No. G.
3. The FCC Site Registration No. is 966073.
4. The VCCI Site Registration No. is G-137.
5. The CANADA Site Registration No. is IC 7450H-2.
6. Tested Date: Sep. 09 to 12, 2015

4.1.3 Test Procedure

- a. The EUT was placed on the top of a rotating table 0.8 meters (for below 1GHz) / 1.5 meters (for above 1GHz) above the ground at 3 meter chamber room for test. The table was rotated 360 degrees to determine the position of the highest radiation.
- b. The EUT was set 3 meters away from the interference-receiving antenna, which was mounted on the top of a variable-height antenna tower.
- c. The height of antenna is varied from one meter to four meters above the ground to determine the maximum value of the field strength. Both horizontal and vertical polarizations of the antenna are set to make the measurement.
- d. For each suspected emission, the EUT was arranged to its worst case and then the antenna was tuned to heights from 1 meter to 4 meters and the rotatable table was turned from 0 degrees to 360 degrees to find the maximum reading.
- e. The test-receiver system was set to quasi-peak detect function and specified bandwidth with maximum hold mode when the test frequency is below 1 GHz.
- f. The test-receiver system was set to peak and average detect function and specified bandwidth with maximum hold mode when the test frequency is above 1 GHz. If the peak reading value also meets average limit, measurement with the average detector is unnecessary.

Note:

1. The resolution bandwidth and video bandwidth of test receiver/spectrum analyzer is 120kHz for Quasi-peak detection (QP) at frequency below 1GHz.
2. The resolution bandwidth of test receiver/spectrum analyzer is 1 MHz and the video bandwidth is 3 MHz for Peak detection (PK) at frequency above 1GHz.
3. The resolution bandwidth of test receiver/spectrum analyzer is 1MHz and the video bandwidth is 3MHz for RMS Average (Duty cycle < 98%) for Average detection (AV) at frequency above 1GHz, then the measurement results was added to a correction factor ($10 \log(1/\text{duty cycle})$).
4. The resolution bandwidth of test receiver/spectrum analyzer is 1MHz and the video bandwidth is 10Hz (Duty cycle $\geq 98\%$) for Average detection (AV) at frequency above 1GHz.
5. All modes of operation were investigated and the worst-case emissions are reported.

4.1.4 Deviation from Test Standard

No deviation.

4.1.5 Test Setup

<Frequency Range below 1GHz>

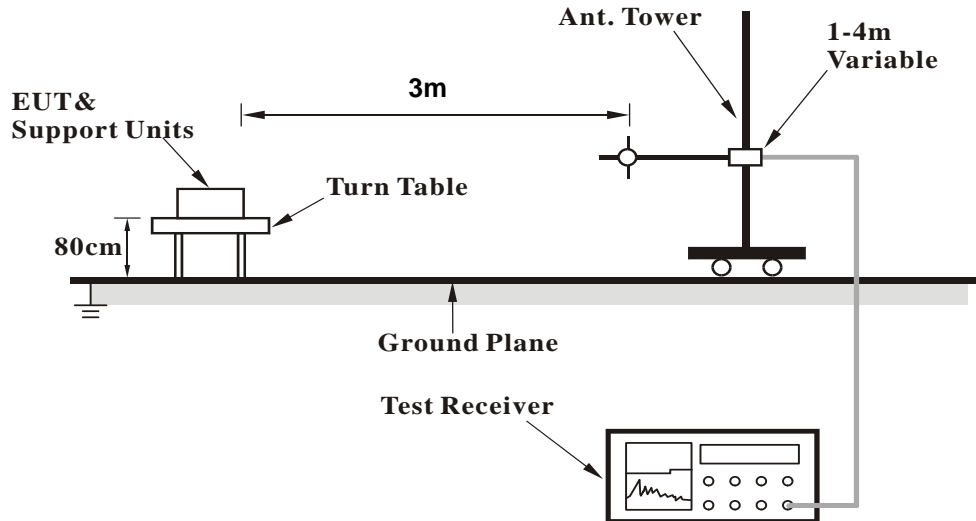

<Frequency Range above 1GHz>

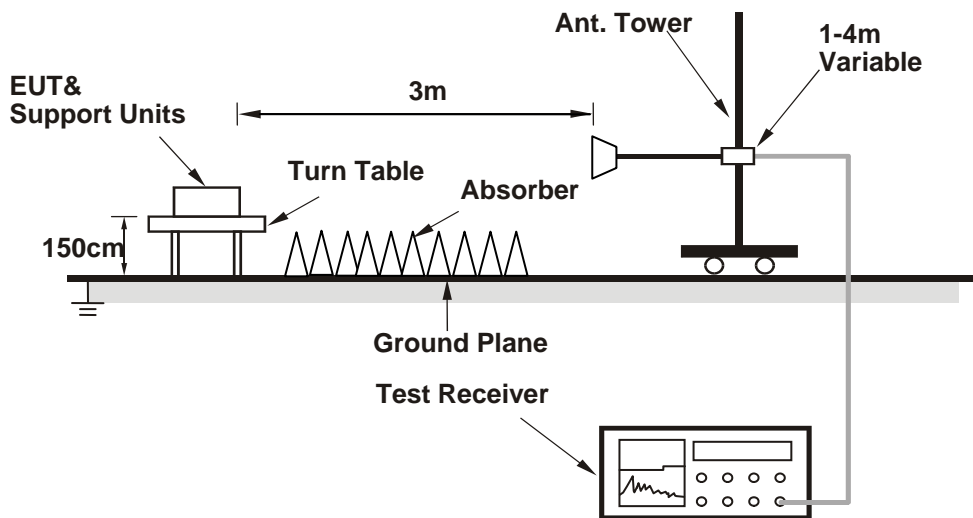

For the actual test configuration, please refer to the attached file (Test Setup Photo).

4.1.6 EUT Operating Condition

1. Connect the EUT with the support unit A (Notebook Computer) which is placed on remote site.
2. Controlling software (MTool_2.0.1.1.exe) has been activated to set the EUT on specific status.

4.1.7 Test Results

Above 1GHz Data:

CDD Mode

802.11a

CHANNEL	TX Channel 36	DETECTOR FUNCTION	Peak (PK)
FREQUENCY RANGE	1GHz ~ 40GHz		Average (AV)

ANTENNA POLARITY & TEST DISTANCE: HORIZONTAL AT 3 M								
NO.	FREQ. (MHz)	EMISSION LEVEL (dBuV/m)	LIMIT (dBuV/m)	MARGIN (dB)	ANTENNA HEIGHT (m)	TABLE ANGLE (Degree)	RAW VALUE (dBuV)	CORRECTION FACTOR (dB/m)
1	5021.00	62.3 PK	74.0	-11.7	1.44 H	72	54.41	7.89
2	5021.00	51.8 AV	54.0	-2.2	1.44 H	72	43.91	7.89
3	5150.00	66.6 PK	74.0	-7.4	1.62 H	69	58.27	8.33
4	5150.00	50.8 AV	54.0	-3.2	1.62 H	69	42.47	8.33
5	*5180.00	114.1 PK			1.62 H	69	105.63	8.47
6	*5180.00	104.5 AV			1.62 H	69	96.03	8.47
7	5421.00	56.6 PK	74.0	-17.4	1.55 H	81	47.59	9.01
8	5421.00	46.5 AV	54.0	-7.5	1.55 H	81	37.49	9.01
9	#5611.00	55.9 PK	74.0	-18.1	1.43 H	225	46.51	9.39
10	#5611.00	46.6 AV	54.0	-7.4	1.43 H	225	37.21	9.39
11	#10360.00	60.1 PK	74.0	-13.9	1.86 H	360	45.60	14.50
12	#10360.00	48.6 AV	54.0	-5.4	1.86 H	360	34.10	14.50
13	15540.00	66.6 PK	74.0	-7.4	1.67 H	141	47.92	18.68
14	15540.00	51.3 AV	54.0	-2.7	1.67 H	141	32.62	18.68

ANTENNA POLARITY & TEST DISTANCE: VERTICAL AT 3 M								
NO.	FREQ. (MHz)	EMISSION LEVEL (dBuV/m)	LIMIT (dBuV/m)	MARGIN (dB)	ANTENNA HEIGHT (m)	TABLE ANGLE (Degree)	RAW VALUE (dBuV)	CORRECTION FACTOR (dB/m)
1	5021.00	62.2 PK	74.0	-11.8	1.74 V	360	54.31	7.89
2	5021.00	52.1 AV	54.0	-1.9	1.74 V	360	44.21	7.89
3	5150.00	67.0 PK	74.0	-7.0	1.76 V	345	58.67	8.33
4	5150.00	50.7 AV	54.0	-3.3	1.76 V	345	42.37	8.33
5	*5180.00	115.4 PK			1.76 V	345	106.93	8.47
6	*5180.00	105.4 AV			1.76 V	345	96.93	8.47
7	5421.00	56.5 PK	74.0	-17.5	1.61 V	326	47.49	9.01
8	5421.00	46.6 AV	54.0	-7.4	1.61 V	326	37.59	9.01
9	#5611.00	56.1 PK	74.0	-17.9	1.54 V	345	46.71	9.39
10	#5611.00	46.7 AV	54.0	-7.3	1.54 V	345	37.31	9.39
11	#10360.00	59.5 PK	74.0	-14.5	1.59 V	12	45.00	14.50
12	#10360.00	48.7 AV	54.0	-5.3	1.59 V	12	34.20	14.50
13	15540.00	62.7 PK	74.0	-11.3	1.41 V	72	44.02	18.68
14	15540.00	49.5 AV	54.0	-4.5	1.41 V	72	30.82	18.68

REMARKS:

1. Emission Level(dBuV/m) = Raw Value(dBuV) + Correction Factor(dB/m)
2. Correction Factor(dB/m) = Antenna Factor(dB/m) + Cable Factor(dB) – Pre-Amplifier Factor(dB)
3. The other emission levels were very low against the limit.
4. Margin value = Emission Level – Limit value
5. " * ": Fundamental frequency.
6. " # ": The radiated frequency is out of the restricted band.

CHANNEL	TX Channel 40	DETECTOR FUNCTION	Peak (PK)
FREQUENCY RANGE	1GHz ~ 40GHz		Average (AV)

ANTENNA POLARITY & TEST DISTANCE: HORIZONTAL AT 3 M

NO.	FREQ. (MHz)	EMISSION LEVEL (dBuV/m)	LIMIT (dBuV/m)	MARGIN (dB)	ANTENNA HEIGHT (m)	TABLE ANGLE (Degree)	RAW VALUE (dBuV)	CORRECTION FACTOR (dB/m)
1	5118.00	57.4 PK	74.0	-16.6	1.71 H	60	49.21	8.19
2	5118.00	46.2 AV	54.0	-7.8	1.71 H	60	38.01	8.19
3	*5200.00	114.6 PK			1.67 H	58	106.06	8.54
4	*5200.00	104.3 AV			1.67 H	58	95.76	8.54
5	5366.00	57.0 PK	74.0	-17.0	1.80 H	52	48.15	8.85
6	5366.00	48.1 AV	54.0	-5.9	1.80 H	52	39.25	8.85
7	#10400.00	58.5 PK	74.0	-15.5	1.50 H	320	43.90	14.60
8	#10400.00	43.7 AV	54.0	-10.3	1.50 H	320	29.10	14.60
9	15600.00	61.0 PK	74.0	-13.0	1.59 H	64	42.10	18.90
10	15600.00	49.1 AV	54.0	-4.9	1.59 H	64	30.20	18.90

ANTENNA POLARITY & TEST DISTANCE: VERTICAL AT 3 M

NO.	FREQ. (MHz)	EMISSION LEVEL (dBuV/m)	LIMIT (dBuV/m)	MARGIN (dB)	ANTENNA HEIGHT (m)	TABLE ANGLE (Degree)	RAW VALUE (dBuV)	CORRECTION FACTOR (dB/m)
1	5118.00	58.6 PK	74.0	-15.4	1.83 V	341	50.41	8.19
2	5118.00	48.6 AV	54.0	-5.4	1.83 V	341	40.41	8.19
3	*5200.00	115.0 PK			1.97 V	344	106.46	8.54
4	*5200.00	106.4 AV			1.97 V	344	97.86	8.54
5	5366.00	60.4 PK	74.0	-13.6	1.58 V	321	51.55	8.85
6	5366.00	51.1 AV	54.0	-2.9	1.58 V	321	42.25	8.85
7	#10400.00	53.1 PK	74.0	-20.9	1.68 V	360	38.50	14.60
8	#10400.00	41.5 AV	54.0	-12.5	1.68 V	360	26.90	14.60
9	15600.00	60.1 PK	74.0	-13.9	1.76 V	43	41.20	18.90
10	15600.00	50.4 AV	54.0	-3.6	1.76 V	43	31.50	18.90

REMARKS:

1. Emission Level(dBuV/m) = Raw Value(dBuV) + Correction Factor(dB/m)
2. Correction Factor(dB/m) = Antenna Factor(dB/m) + Cable Factor(dB) – Pre-Amplifier Factor(dB)
3. The other emission levels were very low against the limit.
4. Margin value = Emission Level – Limit value
5. " * ": Fundamental frequency.
6. " # ": The radiated frequency is out of the restricted band.

CHANNEL	TX Channel 48	DETECTOR FUNCTION	Peak (PK)
FREQUENCY RANGE	1GHz ~ 40GHz		Average (AV)

ANTENNA POLARITY & TEST DISTANCE: HORIZONTAL AT 3 M

NO.	FREQ. (MHz)	EMISSION LEVEL (dBuV/m)	LIMIT (dBuV/m)	MARGIN (dB)	ANTENNA HEIGHT (m)	TABLE ANGLE (Degree)	RAW VALUE (dBuV)	CORRECTION FACTOR (dB/m)
1	*5240.00	113.8 PK			1.69 H	48	105.20	8.60
2	*5240.00	103.7 AV			1.69 H	48	95.10	8.60
3	5401.00	61.2 PK	74.0	-12.8	1.69 H	48	52.27	8.93
4	5401.00	51.8 AV	54.0	-2.2	1.69 H	48	42.87	8.93
5	#10480.00	59.6 PK	74.0	-14.4	1.85 H	360	45.13	14.47
6	#10480.00	48.5 AV	54.0	-5.5	1.85 H	360	34.03	14.47
7	15720.00	66.4 PK	74.0	-7.6	1.71 H	130	47.36	19.04
8	15720.00	51.7 AV	54.0	-2.3	1.71 H	130	32.66	19.04

ANTENNA POLARITY & TEST DISTANCE: VERTICAL AT 3 M

NO.	FREQ. (MHz)	EMISSION LEVEL (dBuV/m)	LIMIT (dBuV/m)	MARGIN (dB)	ANTENNA HEIGHT (m)	TABLE ANGLE (Degree)	RAW VALUE (dBuV)	CORRECTION FACTOR (dB/m)
1	*5240.00	115.0 PK			1.77 V	341	106.40	8.60
2	*5240.00	105.7 AV			1.77 V	341	97.10	8.60
3	5401.00	61.6 PK	74.0	-12.4	1.66 V	339	52.67	8.93
4	5401.00	52.2 AV	54.0	-1.8	1.66 V	339	43.27	8.93
5	#10480.00	59.8 PK	74.0	-14.2	1.64 V	21	45.33	14.47
6	#10480.00	48.8 AV	54.0	-5.2	1.64 V	21	34.33	14.47
7	15720.00	62.4 PK	74.0	-11.6	1.43 V	80	43.36	19.04
8	15720.00	49.1 AV	54.0	-4.9	1.43 V	80	30.06	19.04

REMARKS:

1. Emission Level(dBuV/m) = Raw Value(dBuV) + Correction Factor(dB/m)
2. Correction Factor(dB/m) = Antenna Factor(dB/m) + Cable Factor(dB) – Pre-Amplifier Factor(dB)
3. The other emission levels were very low against the limit.
4. Margin value = Emission Level – Limit value
5. " * ": Fundamental frequency.
6. " # ": The radiated frequency is out of the restricted band.

CHANNEL	TX Channel 149	DETECTOR FUNCTION	Peak (PK)
FREQUENCY RANGE	1GHz ~ 40GHz		Average (AV)

ANTENNA POLARITY & TEST DISTANCE: HORIZONTAL AT 3 M

NO.	FREQ. (MHz)	EMISSION LEVEL (dBuV/m)	LIMIT (dBuV/m)	MARGIN (dB)	ANTENNA HEIGHT (m)	TABLE ANGLE (Degree)	RAW VALUE (dBuV)	CORRECTION FACTOR (dB/m)
1	#5662.00	58.3 PK	74.0	-15.7	1.46 H	221	48.77	9.53
2	#5662.00	48.4 AV	54.0	-5.6	1.46 H	221	38.87	9.53
3	#5725.00	73.8 PK	78.2	-4.4	1.55 H	184	64.10	9.70
4	*5745.00	110.8 PK			1.67 H	33	101.04	9.76
5	*5745.00	102.0 AV			1.67 H	33	92.24	9.76
6	#5902.00	57.6 PK	74.0	-16.4	1.75 H	206	47.64	9.96
7	#5902.00	48.3 AV	54.0	-5.7	1.75 H	206	38.34	9.96
8	11490.00	54.9 PK	74.0	-19.1	2.29 H	338	40.04	14.86
9	11490.00	43.4 AV	54.0	-10.6	2.29 H	338	28.54	14.86
10	#17235.00	68.9 PK	74.0	-5.1	1.93 H	312	45.67	23.23
11	#17235.00	53.8 AV	54.0	-0.2	1.93 H	312	30.57	23.23

ANTENNA POLARITY & TEST DISTANCE: VERTICAL AT 3 M

NO.	FREQ. (MHz)	EMISSION LEVEL (dBuV/m)	LIMIT (dBuV/m)	MARGIN (dB)	ANTENNA HEIGHT (m)	TABLE ANGLE (Degree)	RAW VALUE (dBuV)	CORRECTION FACTOR (dB/m)
1	#5662.00	58.5 PK	74.0	-15.5	1.45 V	332	48.97	9.53
2	#5662.00	50.1 AV	54.0	-3.9	1.45 V	332	40.57	9.53
3	#5725.00	75.8 PK	78.2	-2.4	1.51 V	334	66.10	9.70
4	*5745.00	113.2 PK			1.51 V	334	103.44	9.76
5	*5745.00	104.2 AV			1.51 V	334	94.44	9.76
6	#5902.00	59.3 PK	74.0	-14.7	1.73 V	333	49.34	9.96
7	#5902.00	50.2 AV	54.0	-3.8	1.73 V	333	40.24	9.96
8	11490.00	58.0 PK	74.0	-16.0	1.20 V	358	43.14	14.86
9	11490.00	44.4 AV	54.0	-9.6	1.20 V	358	29.54	14.86
10	#17235.00	69.7 PK	74.0	-4.3	1.64 V	178	46.47	23.23
11	#17235.00	53.6 AV	54.0	-0.4	1.64 V	178	30.37	23.23

REMARKS:

1. Emission Level(dBuV/m) = Raw Value(dBuV) + Correction Factor(dB/m)
2. Correction Factor(dB/m) = Antenna Factor(dB/m) + Cable Factor(dB) – Pre-Amplifier Factor(dB)
3. The other emission levels were very low against the limit.
4. Margin value = Emission Level – Limit value
5. " * ": Fundamental frequency.
6. " # ": The radiated frequency is out of the restricted band.

CHANNEL	TX Channel 157	DETECTOR FUNCTION	Peak (PK)
FREQUENCY RANGE	1GHz ~ 40GHz		Average (AV)

ANTENNA POLARITY & TEST DISTANCE: HORIZONTAL AT 3 M

NO.	FREQ. (MHz)	EMISSION LEVEL (dBuV/m)	LIMIT (dBuV/m)	MARGIN (dB)	ANTENNA HEIGHT (m)	TABLE ANGLE (Degree)	RAW VALUE (dBuV)	CORRECTION FACTOR (dB/m)
1	#5703.00	59.8 PK	74.0	-14.2	1.70 H	216	50.16	9.64
2	#5703.00	45.6 AV	54.0	-8.4	1.70 H	216	35.96	9.64
3	#5725.00	56.4 PK	78.2	-21.8	1.70 H	47	46.70	9.70
4	*5785.00	111.8 PK			1.70 H	47	101.95	9.85
5	*5785.00	101.1 AV			1.70 H	47	91.25	9.85
6	#5850.00	60.2 PK	78.2	-18.0	1.70 H	47	50.28	9.92
7	#5864.00	60.3 PK	74.0	-13.7	1.49 H	178	50.37	9.93
8	#5864.00	48.4 AV	54.0	-5.6	1.49 H	178	38.47	9.93
9	11570.00	54.6 PK	74.0	-19.4	2.29 H	332	39.40	15.20
10	11570.00	43.1 AV	54.0	-10.9	2.29 H	332	27.90	15.20
11	#17355.00	68.5 PK	74.0	-5.5	1.86 H	310	44.94	23.56
12	#17355.00	53.8 AV	54.0	-0.2	1.86 H	310	30.24	23.56

ANTENNA POLARITY & TEST DISTANCE: VERTICAL AT 3 M

NO.	FREQ. (MHz)	EMISSION LEVEL (dBuV/m)	LIMIT (dBuV/m)	MARGIN (dB)	ANTENNA HEIGHT (m)	TABLE ANGLE (Degree)	RAW VALUE (dBuV)	CORRECTION FACTOR (dB/m)
1	#5703.00	61.5 PK	74.0	-12.5	1.68 V	360	51.86	9.64
2	#5703.00	48.7 AV	54.0	-5.3	1.68 V	360	39.06	9.64
3	#5725.00	58.6 PK	78.2	-19.6	1.59 V	353	48.90	9.70
4	*5785.00	113.1 PK			1.59 V	353	103.25	9.85
5	*5785.00	102.9 AV			1.59 V	353	93.05	9.85
6	#5850.00	61.7 PK	78.2	-16.5	1.59 V	353	51.78	9.92
7	#5864.00	61.4 PK	74.0	-12.6	1.61 V	338	51.47	9.93
8	#5864.00	49.5 AV	54.0	-4.5	1.61 V	338	39.57	9.93
9	11570.00	58.5 PK	74.0	-15.5	1.15 V	360	43.30	15.20
10	11570.00	44.9 AV	54.0	-9.1	1.15 V	360	29.70	15.20
11	#17355.00	66.6 PK	74.0	-7.4	1.63 V	169	43.04	23.56
12	#17355.00	50.5 AV	54.0	-3.5	1.63 V	169	26.94	23.56

REMARKS:

1. Emission Level(dBuV/m) = Raw Value(dBuV) + Correction Factor(dB/m)
2. Correction Factor(dB/m) = Antenna Factor(dB/m) + Cable Factor(dB) – Pre-Amplifier Factor(dB)
3. The other emission levels were very low against the limit.
4. Margin value = Emission Level – Limit value
5. " * ": Fundamental frequency.
6. " # ": The radiated frequency is out of the restricted band.

CHANNEL	TX Channel 165	DETECTOR FUNCTION	Peak (PK)
FREQUENCY RANGE	1GHz ~ 40GHz		Average (AV)

ANTENNA POLARITY & TEST DISTANCE: HORIZONTAL AT 3 M

NO.	FREQ. (MHz)	EMISSION LEVEL (dBuV/m)	LIMIT (dBuV/m)	MARGIN (dB)	ANTENNA HEIGHT (m)	TABLE ANGLE (Degree)	RAW VALUE (dBuV)	CORRECTION FACTOR (dB/m)
1	#5706.00	59.6 PK	74.0	-14.4	1.46 H	171	49.95	9.65
2	#5706.00	46.5 AV	54.0	-7.5	1.46 H	171	36.85	9.65
3	*5825.00	112.8 PK			1.75 H	40	102.89	9.91
4	*5825.00	100.9 AV			1.75 H	40	90.99	9.91
5	#5850.00	70.4 PK	78.2	-7.8	1.75 H	40	60.48	9.92
6	#5860.00	65.8 PK	74.0	-8.2	1.75 H	40	55.87	9.93
7	#5860.00	46.4 AV	54.0	-7.6	1.75 H	40	36.47	9.93
8	#5863.00	56.3 PK	74.0	-17.7	1.55 H	231	46.37	9.93
9	#5863.00	47.2 AV	54.0	-6.8	1.55 H	231	37.27	9.93
10	11650.00	55.0 PK	74.0	-19.0	2.28 H	334	39.60	15.40
11	11650.00	43.5 AV	54.0	-10.5	2.28 H	334	28.10	15.40
12	#17475.00	69.3 PK	74.0	-4.7	1.86 H	311	45.21	24.09
13	#17475.00	53.9 AV	54.0	-0.1	1.86 H	311	29.81	24.09

ANTENNA POLARITY & TEST DISTANCE: VERTICAL AT 3 M

NO.	FREQ. (MHz)	EMISSION LEVEL (dBuV/m)	LIMIT (dBuV/m)	MARGIN (dB)	ANTENNA HEIGHT (m)	TABLE ANGLE (Degree)	RAW VALUE (dBuV)	CORRECTION FACTOR (dB/m)
1	#5706.00	60.2 PK	74.0	-13.8	1.66 V	360	50.55	9.65
2	#5706.00	48.9 AV	54.0	-5.1	1.66 V	360	39.25	9.65
3	*5825.00	114.2 PK			1.70 V	359	104.29	9.91
4	*5825.00	103.1 AV			1.70 V	359	93.19	9.91
5	#5850.00	71.2 PK	78.2	-7.0	1.70 V	359	61.28	9.92
6	#5860.00	67.2 PK	74.0	-6.8	1.59 V	353	57.27	9.93
7	#5860.00	48.9 AV	54.0	-5.1	1.59 V	353	38.97	9.93
8	#5863.00	56.4 PK	74.0	-17.6	1.66 V	0	46.47	9.93
9	#5863.00	48.1 AV	54.0	-5.9	1.66 V	0	38.17	9.93
10	11650.00	58.3 PK	74.0	-15.7	1.11 V	360	42.90	15.40
11	11650.00	44.9 AV	54.0	-9.1	1.11 V	360	29.50	15.40
12	#17475.00	67.2 PK	74.0	-6.8	1.68 V	169	43.11	24.09
13	#17475.00	50.9 AV	54.0	-3.1	1.68 V	169	26.81	24.09

REMARKS:

1. Emission Level(dBuV/m) = Raw Value(dBuV) + Correction Factor(dB/m)
2. Correction Factor(dB/m) = Antenna Factor(dB/m) + Cable Factor(dB) – Pre-Amplifier Factor(dB)
3. The other emission levels were very low against the limit.
4. Margin value = Emission Level – Limit value
5. " * ": Fundamental frequency.
6. " # ": The radiated frequency is out of the restricted band.

802.11ac (VHT20)

CHANNEL	TX Channel 36	DETECTOR FUNCTION	Peak (PK)
FREQUENCY RANGE	1GHz ~ 40GHz		Average (AV)

ANTENNA POLARITY & TEST DISTANCE: HORIZONTAL AT 3 M

NO.	FREQ. (MHz)	EMISSION LEVEL (dBuV/m)	LIMIT (dBuV/m)	MARGIN (dB)	ANTENNA HEIGHT (m)	TABLE ANGLE (Degree)	RAW VALUE (dBuV)	CORRECTION FACTOR (dB/m)
1	5150.00	67.5 PK	74.0	-6.5	1.63 H	62	59.17	8.33
2	5150.00	52.4 AV	54.0	-1.6	1.63 H	62	44.07	8.33
3	*5180.00	114.0 PK			1.63 H	62	105.53	8.47
4	*5180.00	104.2 AV			1.63 H	62	95.73	8.47
5	5416.00	52.8 PK	74.0	-21.2	1.78 H	43	43.82	8.98
6	5416.00	41.8 AV	54.0	-12.2	1.78 H	43	32.82	8.98
7	#10360.00	61.7 PK	74.0	-12.3	1.87 H	359	47.20	14.50
8	#10360.00	50.7 AV	54.0	-3.3	1.87 H	359	36.20	14.50
9	15540.00	68.3 PK	74.0	-5.7	1.73 H	156	49.62	18.68
10	15540.00	53.1 AV	54.0	-0.9	1.73 H	156	34.42	18.68

ANTENNA POLARITY & TEST DISTANCE: VERTICAL AT 3 M

NO.	FREQ. (MHz)	EMISSION LEVEL (dBuV/m)	LIMIT (dBuV/m)	MARGIN (dB)	ANTENNA HEIGHT (m)	TABLE ANGLE (Degree)	RAW VALUE (dBuV)	CORRECTION FACTOR (dB/m)
1	5150.00	68.1 PK	74.0	-5.9	1.66 V	338	59.77	8.33
2	5150.00	52.2 AV	54.0	-1.8	1.66 V	338	43.87	8.33
3	*5180.00	113.8 PK			1.66 V	338	105.33	8.47
4	*5180.00	104.4 AV			1.66 V	338	95.93	8.47
5	5416.00	56.2 PK	74.0	-17.8	1.75 V	319	47.22	8.98
6	5416.00	45.4 AV	54.0	-8.6	1.75 V	319	36.42	8.98
7	#10360.00	57.1 PK	74.0	-16.9	1.11 V	360	42.60	14.50
8	#10360.00	43.6 AV	54.0	-10.4	1.11 V	360	29.10	14.50
9	15540.00	65.6 PK	74.0	-8.4	1.74 V	153	46.92	18.68
10	15540.00	49.2 AV	54.0	-4.8	1.74 V	153	30.52	18.68

REMARKS:

1. Emission Level(dBuV/m) = Raw Value(dBuV) + Correction Factor(dB/m)
2. Correction Factor(dB/m) = Antenna Factor(dB/m) + Cable Factor(dB) – Pre-Amplifier Factor(dB)
3. The other emission levels were very low against the limit.
4. Margin value = Emission Level – Limit value
5. " * ": Fundamental frequency.
6. " # ": The radiated frequency is out of the restricted band.

CHANNEL	TX Channel 40	DETECTOR FUNCTION	Peak (PK)
FREQUENCY RANGE	1GHz ~ 40GHz		Average (AV)

ANTENNA POLARITY & TEST DISTANCE: HORIZONTAL AT 3 M

NO.	FREQ. (MHz)	EMISSION LEVEL (dBuV/m)	LIMIT (dBuV/m)	MARGIN (dB)	ANTENNA HEIGHT (m)	TABLE ANGLE (Degree)	RAW VALUE (dBuV)	CORRECTION FACTOR (dB/m)
1	5118.00	57.9 PK	74.0	-16.1	1.80 H	42	49.71	8.19
2	5118.00	45.5 AV	54.0	-8.5	1.80 H	42	37.31	8.19
3	*5200.00	113.1 PK			1.63 H	52	104.56	8.54
4	*5200.00	102.9 AV			1.63 H	52	94.36	8.54
5	5358.00	58.6 PK	74.0	-15.4	1.63 H	52	49.77	8.83
6	5358.00	49.5 AV	54.0	-4.5	1.63 H	52	40.67	8.83
7	#10400.00	59.1 PK	74.0	-14.9	1.91 H	360	44.50	14.60
8	#10400.00	48.1 AV	54.0	-5.9	1.91 H	360	33.50	14.60
9	15600.00	64.1 PK	74.0	-9.9	1.57 H	284	45.20	18.90
10	15600.00	50.8 AV	54.0	-3.2	1.57 H	284	31.90	18.90

ANTENNA POLARITY & TEST DISTANCE: VERTICAL AT 3 M

NO.	FREQ. (MHz)	EMISSION LEVEL (dBuV/m)	LIMIT (dBuV/m)	MARGIN (dB)	ANTENNA HEIGHT (m)	TABLE ANGLE (Degree)	RAW VALUE (dBuV)	CORRECTION FACTOR (dB/m)
1	5118.00	58.7 PK	74.0	-15.3	1.69 V	332	50.51	8.19
2	5118.00	47.9 AV	54.0	-6.1	1.69 V	332	39.71	8.19
3	*5200.00	114.3 PK			1.84 V	330	105.76	8.54
4	*5200.00	104.6 AV			1.84 V	330	96.06	8.54
5	5358.00	60.6 PK	74.0	-13.4	1.61 V	332	51.77	8.83
6	5358.00	50.9 AV	54.0	-3.1	1.61 V	332	42.07	8.83
7	#10400.00	56.3 PK	74.0	-17.7	1.09 V	360	41.70	14.60
8	#10400.00	42.6 AV	54.0	-11.4	1.09 V	360	28.00	14.60
9	15600.00	64.8 PK	74.0	-9.2	1.73 V	143	45.90	18.90
10	15600.00	48.1 AV	54.0	-5.9	1.73 V	143	29.20	18.90

REMARKS:

1. Emission Level(dBuV/m) = Raw Value(dBuV) + Correction Factor(dB/m)
2. Correction Factor(dB/m) = Antenna Factor(dB/m) + Cable Factor(dB) – Pre-Amplifier Factor(dB)
3. The other emission levels were very low against the limit.
4. Margin value = Emission Level – Limit value
5. " * ": Fundamental frequency.
6. " # ": The radiated frequency is out of the restricted band.

CHANNEL	TX Channel 48	DETECTOR FUNCTION	Peak (PK)
FREQUENCY RANGE	1GHz ~ 40GHz		Average (AV)

ANTENNA POLARITY & TEST DISTANCE: HORIZONTAL AT 3 M

NO.	FREQ. (MHz)	EMISSION LEVEL (dBuV/m)	LIMIT (dBuV/m)	MARGIN (dB)	ANTENNA HEIGHT (m)	TABLE ANGLE (Degree)	RAW VALUE (dBuV)	CORRECTION FACTOR (dB/m)
1	*5240.00	113.7 PK			1.61 H	47	105.10	8.60
2	*5240.00	103.3 AV			1.61 H	47	94.70	8.60
3	5398.00	62.1 PK	74.0	-11.9	1.44 H	55	53.18	8.92
4	5398.00	48.6 AV	54.0	-5.4	1.44 H	55	39.68	8.92
5	#10480.00	59.1 PK	74.0	-14.9	1.91 H	354	44.63	14.47
6	#10480.00	48.1 AV	54.0	-5.9	1.91 H	354	33.63	14.47
7	15720.00	66.8 PK	74.0	-7.2	1.54 H	288	47.76	19.04
8	15720.00	50.7 AV	54.0	-3.3	1.54 H	288	31.66	19.04

ANTENNA POLARITY & TEST DISTANCE: VERTICAL AT 3 M

NO.	FREQ. (MHz)	EMISSION LEVEL (dBuV/m)	LIMIT (dBuV/m)	MARGIN (dB)	ANTENNA HEIGHT (m)	TABLE ANGLE (Degree)	RAW VALUE (dBuV)	CORRECTION FACTOR (dB/m)
1	*5240.00	115.0 PK			1.74 V	332	106.40	8.60
2	*5240.00	104.9 AV			1.74 V	332	96.30	8.60
3	5398.00	60.4 PK	74.0	-13.6	1.56 V	327	51.48	8.92
4	5398.00	51.0 AV	54.0	-3.0	1.56 V	327	42.08	8.92
5	#10480.00	55.9 PK	74.0	-18.1	1.03 V	360	41.43	14.47
6	#10480.00	42.3 AV	54.0	-11.7	1.03 V	360	27.83	14.47
7	15720.00	64.5 PK	74.0	-9.5	1.77 V	150	45.46	19.04
8	15720.00	48.0 AV	54.0	-6.0	1.77 V	150	28.96	19.04

REMARKS:

1. Emission Level(dBuV/m) = Raw Value(dBuV) + Correction Factor(dB/m)
2. Correction Factor(dB/m) = Antenna Factor(dB/m) + Cable Factor(dB) – Pre-Amplifier Factor(dB)
3. The other emission levels were very low against the limit.
4. Margin value = Emission Level – Limit value
5. " * ": Fundamental frequency.
6. " # ": The radiated frequency is out of the restricted band.

CHANNEL	TX Channel 149	DETECTOR FUNCTION	Peak (PK)
FREQUENCY RANGE	1GHz ~ 40GHz		Average (AV)

ANTENNA POLARITY & TEST DISTANCE: HORIZONTAL AT 3 M

NO.	FREQ. (MHz)	EMISSION LEVEL (dBuV/m)	LIMIT (dBuV/m)	MARGIN (dB)	ANTENNA HEIGHT (m)	TABLE ANGLE (Degree)	RAW VALUE (dBuV)	CORRECTION FACTOR (dB/m)
1	#5666.00	60.4 PK	74.0	-13.6	1.49 H	47	50.85	9.55
2	#5666.00	51.2 AV	54.0	-2.8	1.49 H	47	41.65	9.55
3	#5715.00	59.4 PK	74.0	-14.6	1.56 H	31	49.72	9.68
4	#5715.00	45.6 AV	54.0	-8.4	1.56 H	31	35.92	9.68
5	#5725.00	74.1 PK	78.2	-4.1	1.56 H	31	64.40	9.70
6	*5745.00	109.8 PK			1.56 H	31	100.04	9.76
7	*5745.00	99.9 AV			1.56 H	31	90.14	9.76
8	11490.00	61.2 PK	74.0	-12.8	1.97 H	349	46.34	14.86
9	11490.00	50.5 AV	54.0	-3.5	1.97 H	349	35.64	14.86
10	#17235.00	70.1 PK	74.0	-3.9	1.89 H	125	46.87	23.23
11	#17235.00	53.7 AV	54.0	-0.3	1.89 H	125	30.47	23.23

ANTENNA POLARITY & TEST DISTANCE: VERTICAL AT 3 M

NO.	FREQ. (MHz)	EMISSION LEVEL (dBuV/m)	LIMIT (dBuV/m)	MARGIN (dB)	ANTENNA HEIGHT (m)	TABLE ANGLE (Degree)	RAW VALUE (dBuV)	CORRECTION FACTOR (dB/m)
1	#5666.00	63.0 PK	74.0	-11.0	1.80 V	359	53.45	9.55
2	#5666.00	53.1 AV	54.0	-0.9	1.80 V	359	43.55	9.55
3	#5715.00	61.1 PK	74.0	-12.9	1.77 V	356	51.42	9.68
4	#5715.00	47.1 AV	54.0	-6.9	1.77 V	356	37.42	9.68
5	#5725.00	76.2 PK	78.2	-2.0	1.77 V	356	66.50	9.70
6	*5745.00	110.9 PK			1.77 V	356	101.14	9.76
7	*5745.00	101.3 AV			1.77 V	356	91.54	9.76
8	11490.00	58.5 PK	74.0	-15.5	1.00 V	360	43.64	14.86
9	11490.00	45.1 AV	54.0	-8.9	1.00 V	360	30.24	14.86
10	#17235.00	66.8 PK	74.0	-7.2	1.76 V	159	43.57	23.23
11	#17235.00	50.6 AV	54.0	-3.4	1.76 V	159	27.37	23.23

REMARKS:

1. Emission Level(dBuV/m) = Raw Value(dBuV) + Correction Factor(dB/m)
2. Correction Factor(dB/m) = Antenna Factor(dB/m) + Cable Factor(dB) – Pre-Amplifier Factor(dB)
3. The other emission levels were very low against the limit.
4. Margin value = Emission Level – Limit value
5. " * ": Fundamental frequency.
6. " # ": The radiated frequency is out of the restricted band.

CHANNEL	TX Channel 157	DETECTOR FUNCTION	Peak (PK)
FREQUENCY RANGE	1GHz ~ 40GHz		Average (AV)

ANTENNA POLARITY & TEST DISTANCE: HORIZONTAL AT 3 M

NO.	FREQ. (MHz)	EMISSION LEVEL (dBuV/m)	LIMIT (dBuV/m)	MARGIN (dB)	ANTENNA HEIGHT (m)	TABLE ANGLE (Degree)	RAW VALUE (dBuV)	CORRECTION FACTOR (dB/m)
1	#5706.00	58.4 PK	74.0	-15.6	1.52 H	39	48.75	9.65
2	#5706.00	46.6 AV	54.0	-7.4	1.52 H	39	36.95	9.65
3	#5725.00	53.2 PK	78.2	-25.0	1.51 H	40	43.50	9.70
4	*5785.00	109.9 PK			1.51 H	40	100.05	9.85
5	*5785.00	100.3 AV			1.51 H	40	90.45	9.85
6	#5850.00	60.4 PK	78.2	-17.8	1.51 H	40	50.48	9.92
7	#5863.00	57.6 PK	74.0	-16.4	1.49 H	34	47.67	9.93
8	#5863.00	47.2 AV	54.0	-6.8	1.49 H	34	37.27	9.93
9	11570.00	60.9 PK	74.0	-13.1	1.98 H	357	45.70	15.20
10	11570.00	50.0 AV	54.0	-4.0	1.98 H	357	34.80	15.20
11	#17355.00	70.0 PK	74.0	-4.0	1.91 H	111	46.44	23.56
12	#17355.00	53.8 AV	54.0	-0.2	1.91 H	111	30.24	23.56

ANTENNA POLARITY & TEST DISTANCE: VERTICAL AT 3 M

NO.	FREQ. (MHz)	EMISSION LEVEL (dBuV/m)	LIMIT (dBuV/m)	MARGIN (dB)	ANTENNA HEIGHT (m)	TABLE ANGLE (Degree)	RAW VALUE (dBuV)	CORRECTION FACTOR (dB/m)
1	#5706.00	60.0 PK	74.0	-14.0	1.58 V	334	50.35	9.65
2	#5706.00	49.3 AV	54.0	-4.7	1.58 V	334	39.65	9.65
3	#5725.00	53.8 PK	78.2	-24.4	1.68 V	332	44.10	9.70
4	*5785.00	111.2 PK			1.68 V	332	101.35	9.85
5	*5785.00	101.2 AV			1.68 V	332	91.35	9.85
6	#5850.00	61.3 PK	78.2	-16.9	1.68 V	332	51.38	9.92
7	#5863.00	58.3 PK	74.0	-15.7	1.67 V	352	48.37	9.93
8	#5863.00	48.7 AV	54.0	-5.3	1.67 V	352	38.77	9.93
9	11570.00	59.1 PK	74.0	-14.9	1.02 V	360	43.90	15.20
10	11570.00	45.5 AV	54.0	-8.5	1.02 V	360	30.30	15.20
11	#17355.00	66.5 PK	74.0	-7.5	1.73 V	170	42.94	23.56
12	#17355.00	50.4 AV	54.0	-3.6	1.73 V	170	26.84	23.56

REMARKS:

1. Emission Level(dBuV/m) = Raw Value(dBuV) + Correction Factor(dB/m)
2. Correction Factor(dB/m) = Antenna Factor(dB/m) + Cable Factor(dB) – Pre-Amplifier Factor(dB)
3. The other emission levels were very low against the limit.
4. Margin value = Emission Level – Limit value
5. " * ": Fundamental frequency.
6. " # ": The radiated frequency is out of the restricted band.

CHANNEL	TX Channel 165	DETECTOR FUNCTION	Peak (PK)
FREQUENCY RANGE	1GHz ~ 40GHz		Average (AV)

ANTENNA POLARITY & TEST DISTANCE: HORIZONTAL AT 3 M

NO.	FREQ. (MHz)	EMISSION LEVEL (dBuV/m)	LIMIT (dBuV/m)	MARGIN (dB)	ANTENNA HEIGHT (m)	TABLE ANGLE (Degree)	RAW VALUE (dBuV)	CORRECTION FACTOR (dB/m)
1	#5662.00	55.8 PK	74.0	-18.2	1.47 H	42	46.27	9.53
2	#5662.00	45.4 AV	54.0	-8.6	1.47 H	42	35.87	9.53
3	*5825.00	110.2 PK			1.56 H	48	100.29	9.91
4	*5825.00	99.8 AV			1.56 H	48	89.89	9.91
5	#5850.00	71.4 PK	78.2	-6.8	1.56 H	48	61.48	9.92
6	#5860.00	63.8 PK	74.0	-10.2	1.56 H	48	53.87	9.93
7	#5860.00	47.2 AV	54.0	-6.8	1.56 H	48	37.27	9.93
8	11650.00	61.1 PK	74.0	-12.9	2.01 H	353	45.70	15.40
9	11650.00	50.0 AV	54.0	-4.0	2.01 H	353	34.60	15.40
10	#17475.00	69.0 PK	74.0	-5.0	1.80 H	314	44.91	24.09
11	#17475.00	53.9 AV	54.0	-0.1	1.80 H	314	29.81	24.09

ANTENNA POLARITY & TEST DISTANCE: VERTICAL AT 3 M

NO.	FREQ. (MHz)	EMISSION LEVEL (dBuV/m)	LIMIT (dBuV/m)	MARGIN (dB)	ANTENNA HEIGHT (m)	TABLE ANGLE (Degree)	RAW VALUE (dBuV)	CORRECTION FACTOR (dB/m)
1	#5662.00	56.2 PK	74.0	-17.8	1.77 V	23	46.67	9.53
2	#5662.00	46.8 AV	54.0	-7.2	1.77 V	23	37.27	9.53
3	*5825.00	111.4 PK			1.77 V	333	101.49	9.91
4	*5825.00	100.7 AV			1.77 V	333	90.79	9.91
5	#5850.00	73.2 PK	78.2	-5.0	1.77 V	333	63.28	9.92
6	#5860.00	65.0 PK	74.0	-9.0	1.77 V	333	55.07	9.93
7	#5860.00	49.3 AV	54.0	-4.7	1.77 V	333	39.37	9.93
8	11650.00	59.0 PK	74.0	-15.0	1.00 V	360	43.60	15.40
9	11650.00	45.7 AV	54.0	-8.3	1.00 V	360	30.30	15.40
10	#17475.00	66.3 PK	74.0	-7.7	1.78 V	183	42.21	24.09
11	#17475.00	50.1 AV	54.0	-3.9	1.78 V	183	26.01	24.09

REMARKS:

- Emission Level(dBuV/m) = Raw Value(dBuV) + Correction Factor(dB/m)
- Correction Factor(dB/m) = Antenna Factor(dB/m) + Cable Factor(dB) – Pre-Amplifier Factor(dB)
- The other emission levels were very low against the limit.
- Margin value = Emission Level – Limit value
- " * ": Fundamental frequency.
- " # ": The radiated frequency is out of the restricted band.

802.11ac (VHT40)

CHANNEL	TX Channel 38	DETECTOR FUNCTION	Peak (PK)
FREQUENCY RANGE	1GHz ~ 40GHz		Average (AV)

ANTENNA POLARITY & TEST DISTANCE: HORIZONTAL AT 3 M

NO.	FREQ. (MHz)	EMISSION LEVEL (dBuV/m)	LIMIT (dBuV/m)	MARGIN (dB)	ANTENNA HEIGHT (m)	TABLE ANGLE (Degree)	RAW VALUE (dBuV)	CORRECTION FACTOR (dB/m)
1	5150.00	66.8 PK	74.0	-7.2	1.45 H	68	58.47	8.33
2	5150.00	53.7 AV	54.0	-0.3	1.45 H	68	45.37	8.33
3	*5190.00	109.2 PK			1.45 H	68	100.70	8.50
4	*5190.00	99.2 AV			1.45 H	68	90.70	8.50
5	5350.00	59.8 PK	74.0	-14.2	1.45 H	68	51.00	8.80
6	5350.00	48.7 AV	54.0	-5.3	1.45 H	68	39.90	8.80
7	#10380.00	59.6 PK	74.0	-14.4	2.02 H	360	45.05	14.55
8	#10380.00	45.3 AV	54.0	-8.7	2.02 H	360	30.75	14.55
9	15570.00	59.8 PK	74.0	-14.2	1.61 H	284	41.01	18.79
10	15570.00	47.9 AV	54.0	-6.1	1.61 H	284	29.11	18.79

ANTENNA POLARITY & TEST DISTANCE: VERTICAL AT 3 M

NO.	FREQ. (MHz)	EMISSION LEVEL (dBuV/m)	LIMIT (dBuV/m)	MARGIN (dB)	ANTENNA HEIGHT (m)	TABLE ANGLE (Degree)	RAW VALUE (dBuV)	CORRECTION FACTOR (dB/m)
1	5150.00	67.5 PK	74.0	-6.5	2.06 V	344	59.17	8.33
2	5150.00	53.9 AV	54.0	-0.1	2.06 V	344	45.57	8.33
3	*5190.00	109.0 PK			2.06 V	344	100.50	8.50
4	*5190.00	98.6 AV			2.06 V	344	90.10	8.50
5	5350.00	62.5 PK	74.0	-11.5	2.06 V	344	53.70	8.80
6	5350.00	52.1 AV	54.0	-1.9	2.06 V	344	43.30	8.80
7	#10380.00	58.5 PK	74.0	-15.5	1.07 V	360	43.95	14.55
8	#10380.00	44.1 AV	54.0	-9.9	1.07 V	360	29.55	14.55
9	15570.00	58.9 PK	74.0	-15.1	1.78 V	141	40.11	18.79
10	15570.00	45.3 AV	54.0	-8.7	1.78 V	141	26.51	18.79

REMARKS:

- Emission Level(dBuV/m) = Raw Value(dBuV) + Correction Factor(dB/m)
- Correction Factor(dB/m) = Antenna Factor(dB/m) + Cable Factor(dB) – Pre-Amplifier Factor(dB)
- The other emission levels were very low against the limit.
- Margin value = Emission Level – Limit value
- " * ": Fundamental frequency.
- " # ": The radiated frequency is out of the restricted band.

CHANNEL	TX Channel 46	DETECTOR FUNCTION	Peak (PK)
FREQUENCY RANGE	1GHz ~ 40GHz		Average (AV)

ANTENNA POLARITY & TEST DISTANCE: HORIZONTAL AT 3 M

NO.	FREQ. (MHz)	EMISSION LEVEL (dBuV/m)	LIMIT (dBuV/m)	MARGIN (dB)	ANTENNA HEIGHT (m)	TABLE ANGLE (Degree)	RAW VALUE (dBuV)	CORRECTION FACTOR (dB/m)
1	5150.00	61.3 PK	74.0	-12.7	1.49 H	68	52.97	8.33
2	5150.00	51.1 AV	54.0	-2.9	1.49 H	68	42.77	8.33
3	*5230.00	112.7 PK			1.49 H	68	104.11	8.59
4	*5230.00	101.1 AV			1.49 H	68	92.51	8.59
5	5393.00	59.7 PK	74.0	-14.3	1.59 H	43	50.79	8.91
6	5393.00	48.7 AV	54.0	-5.3	1.59 H	43	39.79	8.91
7	#10460.00	59.7 PK	74.0	-14.3	2.01 H	360	45.19	14.51
8	#10460.00	45.5 AV	54.0	-8.5	2.01 H	360	30.99	14.51
9	15690.00	60.3 PK	74.0	-13.7	1.61 H	284	41.33	18.97
10	15690.00	48.3 AV	54.0	-5.7	1.61 H	284	29.33	18.97

ANTENNA POLARITY & TEST DISTANCE: VERTICAL AT 3 M

NO.	FREQ. (MHz)	EMISSION LEVEL (dBuV/m)	LIMIT (dBuV/m)	MARGIN (dB)	ANTENNA HEIGHT (m)	TABLE ANGLE (Degree)	RAW VALUE (dBuV)	CORRECTION FACTOR (dB/m)
1	5150.00	61.5 PK	74.0	-12.5	1.54 V	306	53.17	8.33
2	5150.00	51.6 AV	54.0	-2.4	1.54 V	306	43.27	8.33
3	*5230.00	112.5 PK			1.54 V	306	103.91	8.59
4	*5230.00	102.2 AV			1.54 V	306	93.61	8.59
5	5393.00	63.1 PK	74.0	-10.9	1.84 V	328	54.19	8.91
6	5393.00	53.8 AV	54.0	-0.2	1.84 V	328	44.89	8.91
7	#10460.00	58.9 PK	74.0	-15.1	1.12 V	360	44.39	14.51
8	#10460.00	44.4 AV	54.0	-9.6	1.12 V	360	29.89	14.51
9	15690.00	59.2 PK	74.0	-14.8	1.78 V	153	40.23	18.97
10	15690.00	45.6 AV	54.0	-8.4	1.78 V	153	26.63	18.97

REMARKS:

1. Emission Level(dBuV/m) = Raw Value(dBuV) + Correction Factor(dB/m)
2. Correction Factor(dB/m) = Antenna Factor(dB/m) + Cable Factor(dB) – Pre-Amplifier Factor(dB)
3. The other emission levels were very low against the limit.
4. Margin value = Emission Level – Limit value
5. " * ": Fundamental frequency.
6. " # ": The radiated frequency is out of the restricted band.

CHANNEL	TX Channel 151	DETECTOR FUNCTION	Peak (PK)
FREQUENCY RANGE	1GHz ~ 40GHz		Average (AV)

ANTENNA POLARITY & TEST DISTANCE: HORIZONTAL AT 3 M

NO.	FREQ. (MHz)	EMISSION LEVEL (dBuV/m)	LIMIT (dBuV/m)	MARGIN (dB)	ANTENNA HEIGHT (m)	TABLE ANGLE (Degree)	RAW VALUE (dBuV)	CORRECTION FACTOR (dB/m)
1	#5715.00	68.3 PK	74.0	-5.7	1.30 H	294	58.62	9.68
2	#5715.00	53.3 AV	54.0	-0.7	1.30 H	294	43.62	9.68
3	#5725.00	72.0 PK	78.2	-6.2	1.30 H	294	62.30	9.70
4	*5755.00	108.5 PK			1.30 H	294	98.73	9.77
5	*5755.00	98.1 AV			1.30 H	294	88.33	9.77
6	#5910.00	60.0 PK	74.0	-14.0	1.82 H	69	50.00	10.00
7	#5910.00	49.3 AV	54.0	-4.7	1.82 H	69	39.30	10.00
8	11510.00	59.6 PK	74.0	-14.4	1.97 H	360	44.75	14.85
9	11510.00	45.2 AV	54.0	-8.8	1.97 H	360	30.35	14.85
10	#17265.00	60.7 PK	74.0	-13.3	1.64 H	292	37.47	23.23
11	#17265.00	48.7 AV	54.0	-5.3	1.64 H	292	25.47	23.23

ANTENNA POLARITY & TEST DISTANCE: VERTICAL AT 3 M

NO.	FREQ. (MHz)	EMISSION LEVEL (dBuV/m)	LIMIT (dBuV/m)	MARGIN (dB)	ANTENNA HEIGHT (m)	TABLE ANGLE (Degree)	RAW VALUE (dBuV)	CORRECTION FACTOR (dB/m)
1	#5715.00	68.4 PK	74.0	-5.6	1.60 V	330	58.72	9.68
2	#5715.00	53.8 AV	54.0	-0.2	1.60 V	330	44.12	9.68
3	#5725.00	72.6 PK	78.2	-5.6	1.00 V	0	62.90	9.70
4	*5755.00	110.5 PK			1.60 V	330	100.73	9.77
5	*5755.00	98.6 AV			1.60 V	330	88.83	9.77
6	#5910.00	61.1 PK	74.0	-12.9	1.72 V	357	51.10	10.00
7	#5910.00	49.8 AV	54.0	-4.2	1.72 V	357	39.80	10.00
8	11510.00	59.5 PK	74.0	-14.5	1.17 V	360	44.65	14.85
9	11510.00	44.7 AV	54.0	-9.3	1.17 V	360	29.85	14.85
10	#17265.00	58.9 PK	74.0	-15.1	1.84 V	157	35.67	23.23
11	#17265.00	45.6 AV	54.0	-8.4	1.84 V	157	22.37	23.23

REMARKS:

1. Emission Level(dBuV/m) = Raw Value(dBuV) + Correction Factor(dB/m)
2. Correction Factor(dB/m) = Antenna Factor(dB/m) + Cable Factor(dB) – Pre-Amplifier Factor(dB)
3. The other emission levels were very low against the limit.
4. Margin value = Emission Level – Limit value
5. " * ": Fundamental frequency.
6. " # ": The radiated frequency is out of the restricted band.

CHANNEL	TX Channel 159	DETECTOR FUNCTION	Peak (PK)
FREQUENCY RANGE	1GHz ~ 40GHz		Average (AV)

ANTENNA POLARITY & TEST DISTANCE: HORIZONTAL AT 3 M

NO.	FREQ. (MHz)	EMISSION LEVEL (dBuV/m)	LIMIT (dBuV/m)	MARGIN (dB)	ANTENNA HEIGHT (m)	TABLE ANGLE (Degree)	RAW VALUE (dBuV)	CORRECTION FACTOR (dB/m)
1	#5715.00	67.0 PK	68.2	-1.2	1.89 H	69	57.32	9.68
2	*5795.00	113.2 PK			1.89 H	69	103.32	9.88
3	*5795.00	102.9 AV			1.89 H	69	93.02	9.88
4	#5850.00	69.5 PK	78.2	-8.7	1.89 H	69	59.58	9.92
5	#5860.00	67.0 PK	68.2	-1.2	1.89 H	69	57.07	9.93
6	11590.00	62.1 PK	74.0	-11.9	1.93 H	360	46.79	15.31
7	11590.00	51.9 AV	54.0	-2.1	1.93 H	360	36.59	15.31
8	#17385.00	67.4 PK	68.2	-0.8	1.40 H	310	43.64	23.76

ANTENNA POLARITY & TEST DISTANCE: VERTICAL AT 3 M

NO.	FREQ. (MHz)	EMISSION LEVEL (dBuV/m)	LIMIT (dBuV/m)	MARGIN (dB)	ANTENNA HEIGHT (m)	TABLE ANGLE (Degree)	RAW VALUE (dBuV)	CORRECTION FACTOR (dB/m)
1	#5715.00	63.8 PK	68.2	-4.4	1.95 V	358	54.12	9.68
2	*5795.00	113.8 PK			1.95 V	358	103.92	9.88
3	*5795.00	102.4 AV			1.95 V	358	92.52	9.88
4	#5850.00	68.5 PK	78.2	-9.7	1.95 V	358	58.58	9.92
5	#5860.00	67.6 PK	68.2	-0.6	1.95 V	358	57.67	9.93
6	11590.00	61.4 PK	74.0	-12.6	1.16 V	360	46.09	15.31
7	11590.00	50.4 AV	54.0	-3.6	1.16 V	360	35.09	15.31
8	#17385.00	65.2 PK	68.2	-3.0	1.89 V	141	41.44	23.76

REMARKS:

1. Emission Level(dBuV/m) = Raw Value(dBuV) + Correction Factor(dB/m)
2. Correction Factor(dB/m) = Antenna Factor(dB/m) + Cable Factor(dB) – Pre-Amplifier Factor(dB)
3. The other emission levels were very low against the limit.
4. Margin value = Emission Level – Limit value
5. " * ": Fundamental frequency.
6. " # ": The radiated frequency is out of the restricted band.

802.11ac (VHT80)

CHANNEL	TX Channel 42	DETECTOR FUNCTION	Peak (PK)
FREQUENCY RANGE	1GHz ~ 40GHz		Average (AV)

ANTENNA POLARITY & TEST DISTANCE: HORIZONTAL AT 3 M

NO.	FREQ. (MHz)	EMISSION LEVEL (dBuV/m)	LIMIT (dBuV/m)	MARGIN (dB)	ANTENNA HEIGHT (m)	TABLE ANGLE (Degree)	RAW VALUE (dBuV)	CORRECTION FACTOR (dB/m)
1	5150.00	66.4 PK	74.0	-7.6	1.63 H	66	58.07	8.33
2	5150.00	53.9 AV	54.0	-0.1	1.63 H	66	45.57	8.33
3	*5210.00	105.6 PK			1.63 H	66	97.05	8.55
4	*5210.00	93.1 AV			1.63 H	66	84.55	8.55
5	5350.00	56.1 PK	74.0	-17.9	1.63 H	66	47.30	8.80
6	5350.00	45.3 AV	54.0	-8.7	1.63 H	66	36.50	8.80
7	#10420.00	59.8 PK	74.0	-14.2	1.93 H	360	45.23	14.57
8	#10420.00	45.7 AV	54.0	-8.3	1.93 H	360	31.13	14.57
9	15630.00	60.2 PK	74.0	-13.8	1.62 H	288	41.27	18.93
10	15630.00	48.4 AV	54.0	-5.6	1.62 H	288	29.47	18.93

ANTENNA POLARITY & TEST DISTANCE: VERTICAL AT 3 M

NO.	FREQ. (MHz)	EMISSION LEVEL (dBuV/m)	LIMIT (dBuV/m)	MARGIN (dB)	ANTENNA HEIGHT (m)	TABLE ANGLE (Degree)	RAW VALUE (dBuV)	CORRECTION FACTOR (dB/m)
1	5150.00	65.1 PK	74.0	-8.9	2.35 V	23	56.77	8.33
2	5150.00	53.6 AV	54.0	-0.4	2.35 V	23	45.27	8.33
3	*5210.00	102.8 PK			2.35 V	23	94.25	8.55
4	*5210.00	92.4 AV			2.35 V	23	83.85	8.55
5	5350.00	55.8 PK	74.0	-18.2	2.35 V	23	47.00	8.80
6	5350.00	45.0 AV	54.0	-9.0	2.35 V	23	36.20	8.80
7	#10420.00	59.9 PK	74.0	-14.1	1.22 V	360	45.33	14.57
8	#10420.00	45.0 AV	54.0	-9.0	1.22 V	360	30.43	14.57
9	15630.00	58.6 PK	74.0	-15.4	1.85 V	171	39.67	18.93
10	15630.00	45.5 AV	54.0	-8.5	1.85 V	171	26.57	18.93

REMARKS:

1. Emission Level(dBuV/m) = Raw Value(dBuV) + Correction Factor(dB/m)
2. Correction Factor(dB/m) = Antenna Factor(dB/m) + Cable Factor(dB) – Pre-Amplifier Factor(dB)
3. The other emission levels were very low against the limit.
4. Margin value = Emission Level – Limit value
5. " * ": Fundamental frequency.
6. " # ": The radiated frequency is out of the restricted band.

CHANNEL	TX Channel 155	DETECTOR FUNCTION	Peak (PK)
FREQUENCY RANGE	1GHz ~ 40GHz		Average (AV)

ANTENNA POLARITY & TEST DISTANCE: HORIZONTAL AT 3 M

NO.	FREQ. (MHz)	EMISSION LEVEL (dBuV/m)	LIMIT (dBuV/m)	MARGIN (dB)	ANTENNA HEIGHT (m)	TABLE ANGLE (Degree)	RAW VALUE (dBuV)	CORRECTION FACTOR (dB/m)
1	#5715.00	68.5 PK	74.0	-5.5	1.85 H	66	58.82	9.68
2	#5715.00	53.9 AV	54.0	-0.1	1.85 H	66	44.22	9.68
3	#5725.00	72.0 PK	78.2	-6.2	1.85 H	66	62.30	9.70
4	*5775.00	105.1 PK			1.85 H	66	95.27	9.83
5	*5775.00	94.3 AV			1.85 H	66	84.47	9.83
6	#5850.00	63.1 PK	78.2	-15.1	1.85 H	66	53.18	9.92
7	#5860.00	60.2 PK	74.0	-13.8	1.85 H	66	50.27	9.93
8	#5860.00	48.9 AV	54.0	-5.1	1.85 H	66	38.97	9.93
9	11550.00	60.1 PK	74.0	-13.9	1.96 H	360	45.01	15.09
10	11550.00	45.5 AV	54.0	-8.5	1.96 H	360	30.41	15.09
11	#17325.00	61.0 PK	74.0	-13.0	1.58 H	290	37.62	23.38
12	#17325.00	48.8 AV	54.0	-5.2	1.58 H	290	25.42	23.38

ANTENNA POLARITY & TEST DISTANCE: VERTICAL AT 3 M

NO.	FREQ. (MHz)	EMISSION LEVEL (dBuV/m)	LIMIT (dBuV/m)	MARGIN (dB)	ANTENNA HEIGHT (m)	TABLE ANGLE (Degree)	RAW VALUE (dBuV)	CORRECTION FACTOR (dB/m)
1	#5715.00	68.7 PK	74.0	-5.3	1.50 V	340	59.02	9.68
2	#5715.00	53.6 AV	54.0	-0.4	1.50 V	340	43.92	9.68
3	#5725.00	70.0 PK	78.2	-8.2	1.50 V	340	60.30	9.70
4	*5775.00	106.1 PK			1.85 V	334	96.27	9.83
5	*5775.00	94.1 AV			1.85 V	334	84.27	9.83
6	#5850.00	62.6 PK	78.2	-15.6	1.50 V	340	52.68	9.92
7	#5860.00	60.1 PK	74.0	-13.9	1.50 V	340	50.17	9.93
8	#5860.00	48.9 AV	54.0	-5.1	1.50 V	340	38.97	9.93
9	11550.00	59.3 PK	74.0	-14.7	1.16 V	360	44.21	15.09
10	11550.00	44.6 AV	54.0	-9.4	1.16 V	360	29.51	15.09
11	#17325.00	59.0 PK	74.0	-15.0	1.87 V	150	35.62	23.38
12	#17325.00	45.5 AV	54.0	-8.5	1.87 V	150	22.12	23.38

REMARKS:

1. Emission Level(dBuV/m) = Raw Value(dBuV) + Correction Factor(dB/m)
2. Correction Factor(dB/m) = Antenna Factor(dB/m) + Cable Factor(dB) – Pre-Amplifier Factor(dB)
3. The other emission levels were very low against the limit.
4. Margin value = Emission Level – Limit value
5. " * ": Fundamental frequency.
6. " # ": The radiated frequency is out of the restricted band.

Below 1GHz Data:

CDD Mode

802.11ac (VHT40)

CHANNEL	TX Channel 159	DETECTOR FUNCTION	Quasi-Peak (QP)
FREQUENCY RANGE	Below 1GHz		

ANTENNA POLARITY & TEST DISTANCE: HORIZONTAL AT 3 M

NO.	FREQ. (MHz)	EMISSION LEVEL (dBuV/m)	LIMIT (dBuV/m)	MARGIN (dB)	ANTENNA HEIGHT (m)	TABLE ANGLE (Degree)	RAW VALUE (dBuV)	CORRECTION FACTOR (dB/m)
1	41.11	30.7 QP	40.0	-9.3	1.42 H	100	44.43	-13.69
2	90.12	35.8 QP	43.5	-7.7	1.45 H	200	54.75	-18.93
3	158.42	37.7 QP	43.5	-5.8	1.64 H	200	50.59	-12.92
4	168.42	40.1 QP	43.5	-3.4	1.64 H	100	53.44	-13.30
5	195.81	32.6 QP	43.5	-10.9	1.64 H	100	48.59	-15.95
6	326.67	35.5 QP	46.0	-10.6	1.24 H	99	46.35	-10.90

ANTENNA POLARITY & TEST DISTANCE: VERTICAL AT 3 M

NO.	FREQ. (MHz)	EMISSION LEVEL (dBuV/m)	LIMIT (dBuV/m)	MARGIN (dB)	ANTENNA HEIGHT (m)	TABLE ANGLE (Degree)	RAW VALUE (dBuV)	CORRECTION FACTOR (dB/m)
1	37.55	35.7 QP	40.0	-4.3	1.24 V	345	49.66	-13.99
2	38.24	33.8 QP	40.0	-6.2	1.24 V	244	47.64	-13.88
3	76.24	36.6 QP	40.0	-3.4	1.24 V	99	53.32	-16.71
4	97.61	36.8 QP	43.5	-6.7	1.45 V	100	54.87	-18.06
5	169.31	36.7 QP	43.5	-6.8	1.44 V	88	50.05	-13.38
6	341.24	35.1 QP	46.0	-10.9	1.24 V	314	45.88	-10.77

REMARKS:

1. Emission Level(dBuV/m) = Raw Value(dBuV) + Correction Factor(dB/m)
2. Correction Factor(dB/m) = Antenna Factor(dB/m) + Cable Factor(dB) – Pre-Amplifier Factor(dB)
3. The other emission levels were very low against the limit.
4. Margin value = Emission Level – Limit value

Above 1GHz Data:

Beamforming Mode

802.11ac (VHT20)

CHANNEL	TX Channel 36	DETECTOR FUNCTION	Peak (PK)
FREQUENCY RANGE	1GHz ~ 40GHz		Average (AV)

ANTENNA POLARITY & TEST DISTANCE: HORIZONTAL AT 3 M

NO.	FREQ. (MHz)	EMISSION LEVEL (dBuV/m)	LIMIT (dBuV/m)	MARGIN (dB)	ANTENNA HEIGHT (m)	TABLE ANGLE (Degree)	RAW VALUE (dBuV)	CORRECTION FACTOR (dB/m)
1	5150.00	68.6 PK	74.0	-5.4	1.65 H	79	60.27	8.33
2	5150.00	52.9 AV	54.0	-1.1	1.65 H	79	44.57	8.33
3	*5180.00	113.6 PK			1.65 H	79	105.13	8.47
4	*5180.00	107.2 AV			1.65 H	79	98.73	8.47
5	#10360.00	57.7 PK	74.0	-16.3	1.99 H	343	43.20	14.50
6	#10360.00	42.0 AV	54.0	-12.0	1.99 H	343	27.50	14.50
7	15540.00	60.2 PK	74.0	-13.8	1.59 H	329	41.52	18.68
8	15540.00	45.0 AV	54.0	-9.0	1.59 H	329	26.32	18.68

ANTENNA POLARITY & TEST DISTANCE: VERTICAL AT 3 M

NO.	FREQ. (MHz)	EMISSION LEVEL (dBuV/m)	LIMIT (dBuV/m)	MARGIN (dB)	ANTENNA HEIGHT (m)	TABLE ANGLE (Degree)	RAW VALUE (dBuV)	CORRECTION FACTOR (dB/m)
1	5150.00	70.2 PK	74.0	-3.8	1.64 V	23	61.87	8.33
2	5150.00	53.7 AV	54.0	-0.3	1.64 V	23	45.37	8.33
3	*5180.00	115.4 PK			1.64 V	23	106.93	8.47
4	*5180.00	108.4 AV			1.64 V	23	99.93	8.47
5	#10360.00	55.6 PK	74.0	-18.4	1.07 V	360	41.10	14.50
6	#10360.00	41.3 AV	54.0	-12.7	1.07 V	360	26.80	14.50
7	15540.00	55.9 PK	74.0	-18.1	1.71 V	140	37.22	18.68
8	15540.00	42.1 AV	54.0	-11.9	1.71 V	140	23.42	18.68

REMARKS:

1. Emission Level(dBuV/m) = Raw Value(dBuV) + Correction Factor(dB/m)
2. Correction Factor(dB/m) = Antenna Factor(dB/m) + Cable Factor(dB) – Pre-Amplifier Factor(dB)
3. The other emission levels were very low against the limit.
4. Margin value = Emission Level – Limit value
5. " * ": Fundamental frequency.
6. " # ": The radiated frequency is out of the restricted band.

CHANNEL	TX Channel 40	DETECTOR FUNCTION	Peak (PK)
FREQUENCY RANGE	1GHz ~ 40GHz		Average (AV)

ANTENNA POLARITY & TEST DISTANCE: HORIZONTAL AT 3 M

NO.	FREQ. (MHz)	EMISSION LEVEL (dBuV/m)	LIMIT (dBuV/m)	MARGIN (dB)	ANTENNA HEIGHT (m)	TABLE ANGLE (Degree)	RAW VALUE (dBuV)	CORRECTION FACTOR (dB/m)
1	*5200.00	115.1 PK			1.66 H	80	106.56	8.54
2	*5200.00	107.1 AV			1.66 H	80	98.56	8.54
3	5368.00	60.8 PK	74.0	-13.2	1.66 H	80	51.94	8.86
4	5368.00	51.2 AV	54.0	-2.8	1.66 H	80	42.34	8.86
5	#10400.00	57.8 PK	74.0	-16.2	2.02 H	356	43.20	14.60
6	#10400.00	42.1 AV	54.0	-11.9	2.02 H	356	27.50	14.60
7	15600.00	60.0 PK	74.0	-14.0	1.58 H	318	41.10	18.90
8	15600.00	44.7 AV	54.0	-9.3	1.58 H	318	25.80	18.90

ANTENNA POLARITY & TEST DISTANCE: VERTICAL AT 3 M

NO.	FREQ. (MHz)	EMISSION LEVEL (dBuV/m)	LIMIT (dBuV/m)	MARGIN (dB)	ANTENNA HEIGHT (m)	TABLE ANGLE (Degree)	RAW VALUE (dBuV)	CORRECTION FACTOR (dB/m)
1	*5200.00	116.7 PK			1.63 V	31	108.16	8.54
2	*5200.00	108.5 AV			1.63 V	31	99.96	8.54
3	5368.00	61.6 PK	74.0	-12.4	1.93 V	326	52.74	8.86
4	5368.00	52.7 AV	54.0	-1.3	1.93 V	326	43.84	8.86
5	#10400.00	55.7 PK	74.0	-18.3	1.06 V	360	41.10	14.60
6	#10400.00	41.5 AV	54.0	-12.5	1.06 V	360	26.90	14.60
7	15600.00	56.4 PK	74.0	-17.6	1.75 V	149	37.50	18.90
8	15600.00	42.3 AV	54.0	-11.7	1.75 V	149	23.40	18.90

REMARKS:

1. Emission Level(dBuV/m) = Raw Value(dBuV) + Correction Factor(dB/m)
2. Correction Factor(dB/m) = Antenna Factor(dB/m) + Cable Factor(dB) – Pre-Amplifier Factor(dB)
3. The other emission levels were very low against the limit.
4. Margin value = Emission Level – Limit value
5. " * ": Fundamental frequency.
6. " # ": The radiated frequency is out of the restricted band.

CHANNEL	TX Channel 48	DETECTOR FUNCTION	Peak (PK)
FREQUENCY RANGE	1GHz ~ 40GHz		Average (AV)

ANTENNA POLARITY & TEST DISTANCE: HORIZONTAL AT 3 M

NO.	FREQ. (MHz)	EMISSION LEVEL (dBuV/m)	LIMIT (dBuV/m)	MARGIN (dB)	ANTENNA HEIGHT (m)	TABLE ANGLE (Degree)	RAW VALUE (dBuV)	CORRECTION FACTOR (dB/m)
1	*5240.00	114.9 PK			1.70 H	75	106.30	8.60
2	*5240.00	107.1 AV			1.70 H	75	98.50	8.60
3	5402.00	61.9 PK	74.0	-12.1	1.70 H	75	52.97	8.93
4	5402.00	51.4 AV	54.0	-2.6	1.70 H	75	42.47	8.93
5	#10480.00	57.9 PK	74.0	-16.1	1.99 H	345	43.43	14.47
6	#10480.00	41.9 AV	54.0	-12.1	1.99 H	345	27.43	14.47
7	15720.00	60.0 PK	74.0	-14.0	1.61 H	315	40.96	19.04
8	15720.00	44.7 AV	54.0	-9.3	1.61 H	315	25.66	19.04

ANTENNA POLARITY & TEST DISTANCE: VERTICAL AT 3 M

NO.	FREQ. (MHz)	EMISSION LEVEL (dBuV/m)	LIMIT (dBuV/m)	MARGIN (dB)	ANTENNA HEIGHT (m)	TABLE ANGLE (Degree)	RAW VALUE (dBuV)	CORRECTION FACTOR (dB/m)
1	*5240.00	116.6 PK			1.63 V	25	108.00	8.60
2	*5240.00	108.4 AV			1.63 V	25	99.80	8.60
3	5402.00	62.4 PK	74.0	-11.6	1.92 V	320	53.47	8.93
4	5402.00	52.8 AV	54.0	-1.2	1.92 V	320	43.87	8.93
5	#10480.00	56.0 PK	74.0	-18.0	1.10 V	360	41.53	14.47
6	#10480.00	41.6 AV	54.0	-12.4	1.10 V	360	27.13	14.47
7	15720.00	56.1 PK	74.0	-17.9	1.72 V	158	37.06	19.04
8	15720.00	42.2 AV	54.0	-11.8	1.72 V	158	23.16	19.04

REMARKS:

1. Emission Level(dBuV/m) = Raw Value(dBuV) + Correction Factor(dB/m)
2. Correction Factor(dB/m) = Antenna Factor(dB/m) + Cable Factor(dB) – Pre-Amplifier Factor(dB)
3. The other emission levels were very low against the limit.
4. Margin value = Emission Level – Limit value
5. " * ": Fundamental frequency.
6. " # ": The radiated frequency is out of the restricted band.

CHANNEL	TX Channel 149	DETECTOR FUNCTION	Peak (PK)
FREQUENCY RANGE	1GHz ~ 40GHz		Average (AV)

ANTENNA POLARITY & TEST DISTANCE: HORIZONTAL AT 3 M

NO.	FREQ. (MHz)	EMISSION LEVEL (dBuV/m)	LIMIT (dBuV/m)	MARGIN (dB)	ANTENNA HEIGHT (m)	TABLE ANGLE (Degree)	RAW VALUE (dBuV)	CORRECTION FACTOR (dB/m)
1	#5713.00	55.8 PK	74.0	-18.2	1.68 H	73	46.13	9.67
2	#5713.00	43.8 AV	54.0	-10.2	1.68 H	73	34.13	9.67
3	#5725.00	63.8 PK	78.2	-14.4	1.70 H	79	54.10	9.70
4	*5745.00	109.4 PK			1.70 H	79	99.64	9.76
5	*5745.00	101.7 AV			1.70 H	79	91.94	9.76
6	11490.00	54.8 PK	74.0	-19.2	2.25 H	327	39.94	14.86
7	11490.00	43.4 AV	54.0	-10.6	2.25 H	327	28.54	14.86
8	#17235.00	71.9 PK	74.0	-2.1	2.18 H	320	48.67	23.23
9	#17235.00	53.7 AV	54.0	-0.3	2.18 H	320	30.47	23.23

ANTENNA POLARITY & TEST DISTANCE: VERTICAL AT 3 M

NO.	FREQ. (MHz)	EMISSION LEVEL (dBuV/m)	LIMIT (dBuV/m)	MARGIN (dB)	ANTENNA HEIGHT (m)	TABLE ANGLE (Degree)	RAW VALUE (dBuV)	CORRECTION FACTOR (dB/m)
1	#5713.00	56.8 PK	74.0	-17.2	1.75 V	360	47.13	9.67
2	#5713.00	44.6 AV	54.0	-9.4	1.75 V	360	34.93	9.67
3	#5725.00	64.6 PK	78.2	-13.6	1.62 V	353	54.90	9.70
4	*5745.00	112.7 PK			1.62 V	353	102.94	9.76
5	*5745.00	102.8 AV			1.62 V	353	93.04	9.76
6	11490.00	57.9 PK	74.0	-16.1	1.11 V	360	43.04	14.86
7	11490.00	44.7 AV	54.0	-9.3	1.11 V	360	29.84	14.86
8	#17235.00	70.3 PK	74.0	-3.7	1.74 V	164	47.07	23.23
9	#17235.00	52.3 AV	54.0	-1.7	1.74 V	164	29.07	23.23

REMARKS:

1. Emission Level(dBuV/m) = Raw Value(dBuV) + Correction Factor(dB/m)
2. Correction Factor(dB/m) = Antenna Factor(dB/m) + Cable Factor(dB) – Pre-Amplifier Factor(dB)
3. The other emission levels were very low against the limit.
4. Margin value = Emission Level – Limit value
5. " * ": Fundamental frequency.
6. " # ": The radiated frequency is out of the restricted band.

CHANNEL	TX Channel 157	DETECTOR FUNCTION	Peak (PK)
FREQUENCY RANGE	1GHz ~ 40GHz		Average (AV)

ANTENNA POLARITY & TEST DISTANCE: HORIZONTAL AT 3 M

NO.	FREQ. (MHz)	EMISSION LEVEL (dBuV/m)	LIMIT (dBuV/m)	MARGIN (dB)	ANTENNA HEIGHT (m)	TABLE ANGLE (Degree)	RAW VALUE (dBuV)	CORRECTION FACTOR (dB/m)
1	#5752.00	56.4 PK	74.0	-17.6	1.68 H	81	46.63	9.77
2	#5752.00	44.1 AV	54.0	-9.9	1.68 H	81	34.33	9.77
3	*5785.00	109.7 PK			1.74 H	79	99.85	9.85
4	*5785.00	101.6 AV			1.74 H	79	91.75	9.85
5	11570.00	55.1 PK	74.0	-18.9	2.23 H	336	39.90	15.20
6	11570.00	43.9 AV	54.0	-10.1	2.23 H	336	28.70	15.20
7	#17355.00	72.1 PK	74.0	-1.9	2.13 H	311	48.54	23.56
8	#17355.00	53.8 AV	54.0	-0.2	2.13 H	311	30.24	23.56

ANTENNA POLARITY & TEST DISTANCE: VERTICAL AT 3 M

NO.	FREQ. (MHz)	EMISSION LEVEL (dBuV/m)	LIMIT (dBuV/m)	MARGIN (dB)	ANTENNA HEIGHT (m)	TABLE ANGLE (Degree)	RAW VALUE (dBuV)	CORRECTION FACTOR (dB/m)
1	#5752.00	56.7 PK	74.0	-17.3	1.77 V	358	46.93	9.77
2	#5752.00	44.5 AV	54.0	-9.5	1.77 V	358	34.73	9.77
3	*5785.00	111.9 PK			1.65 V	340	102.05	9.85
4	*5785.00	103.0 AV			1.65 V	340	93.15	9.85
5	11570.00	57.5 PK	74.0	-16.5	1.14 V	360	42.30	15.20
6	11570.00	44.2 AV	54.0	-9.8	1.14 V	360	29.00	15.20
7	#17355.00	70.3 PK	74.0	-3.7	1.79 V	169	46.74	23.56
8	#17355.00	52.5 AV	54.0	-1.5	1.79 V	169	28.94	23.56

REMARKS:

1. Emission Level(dBuV/m) = Raw Value(dBuV) + Correction Factor(dB/m)
2. Correction Factor(dB/m) = Antenna Factor(dB/m) + Cable Factor(dB) – Pre-Amplifier Factor(dB)
3. The other emission levels were very low against the limit.
4. Margin value = Emission Level – Limit value
5. " * ": Fundamental frequency.
6. " # ": The radiated frequency is out of the restricted band.

CHANNEL	TX Channel 165	DETECTOR FUNCTION	Peak (PK)
FREQUENCY RANGE	1GHz ~ 40GHz		Average (AV)

ANTENNA POLARITY & TEST DISTANCE: HORIZONTAL AT 3 M

NO.	FREQ. (MHz)	EMISSION LEVEL (dBuV/m)	LIMIT (dBuV/m)	MARGIN (dB)	ANTENNA HEIGHT (m)	TABLE ANGLE (Degree)	RAW VALUE (dBuV)	CORRECTION FACTOR (dB/m)
1	*5825.00	110.2 PK			1.71 H	79	100.29	9.91
2	*5825.00	101.2 AV			1.71 H	79	91.29	9.91
3	#5850.00	61.4 PK	78.2	-16.8	1.71 H	79	51.48	9.92
4	#5907.00	55.8 PK	74.0	-18.2	1.63 H	70	45.82	9.98
5	#5907.00	43.8 AV	54.0	-10.2	1.63 H	70	33.82	9.98
6	11650.00	54.8 PK	74.0	-19.2	2.22 H	337	39.40	15.40
7	11650.00	43.4 AV	54.0	-10.6	2.22 H	337	28.00	15.40
8	#17475.00	71.4 PK	74.0	-2.6	2.07 H	313	47.31	24.09
9	#17475.00	53.7 AV	54.0	-0.3	2.07 H	313	29.61	24.09

ANTENNA POLARITY & TEST DISTANCE: VERTICAL AT 3 M

NO.	FREQ. (MHz)	EMISSION LEVEL (dBuV/m)	LIMIT (dBuV/m)	MARGIN (dB)	ANTENNA HEIGHT (m)	TABLE ANGLE (Degree)	RAW VALUE (dBuV)	CORRECTION FACTOR (dB/m)
1	*5825.00	111.5 PK			1.71 V	326	101.59	9.91
2	*5825.00	102.6 AV			1.71 V	326	92.69	9.91
3	#5850.00	62.3 PK	78.2	-15.9	1.71 V	326	52.38	9.92
4	#5907.00	56.4 PK	74.0	-17.6	1.76 V	349	46.42	9.98
5	#5907.00	44.1 AV	54.0	-9.9	1.76 V	349	34.12	9.98
6	11650.00	58.0 PK	74.0	-16.0	1.20 V	359	42.60	15.40
7	11650.00	44.5 AV	54.0	-9.5	1.20 V	359	29.10	15.40
8	#17475.00	70.2 PK	74.0	-3.8	1.78 V	161	46.11	24.09
9	#17475.00	52.6 AV	54.0	-1.4	1.78 V	161	28.51	24.09

REMARKS:

1. Emission Level(dBuV/m) = Raw Value(dBuV) + Correction Factor(dB/m)
2. Correction Factor(dB/m) = Antenna Factor(dB/m) + Cable Factor(dB) – Pre-Amplifier Factor(dB)
3. The other emission levels were very low against the limit.
4. Margin value = Emission Level – Limit value
5. " * ": Fundamental frequency.
6. " # ": The radiated frequency is out of the restricted band.

802.11ac (VHT40)

CHANNEL	TX Channel 38	DETECTOR FUNCTION	Peak (PK)
FREQUENCY RANGE	1GHz ~ 40GHz		Average (AV)

ANTENNA POLARITY & TEST DISTANCE: HORIZONTAL AT 3 M

NO.	FREQ. (MHz)	EMISSION LEVEL (dBuV/m)	LIMIT (dBuV/m)	MARGIN (dB)	ANTENNA HEIGHT (m)	TABLE ANGLE (Degree)	RAW VALUE (dBuV)	CORRECTION FACTOR (dB/m)
1	5150.00	67.8 PK	74.0	-6.2	1.70 H	94	59.47	8.33
2	5150.00	53.6 AV	54.0	-0.4	1.70 H	94	45.27	8.33
3	*5190.00	109.4 PK			1.70 H	94	100.90	8.50
4	*5190.00	100.6 AV			1.70 H	94	92.10	8.50
5	5350.00	58.9 PK	74.0	-15.1	1.70 H	94	50.10	8.80
6	5350.00	47.6 AV	54.0	-6.4	1.70 H	94	38.80	8.80
7	#10380.00	58.0 PK	74.0	-16.0	1.94 H	332	43.45	14.55
8	#10380.00	42.3 AV	54.0	-11.7	1.94 H	332	27.75	14.55
9	15570.00	60.0 PK	74.0	-14.0	1.63 H	344	41.21	18.79
10	15570.00	44.9 AV	54.0	-9.1	1.63 H	344	26.11	18.79

ANTENNA POLARITY & TEST DISTANCE: VERTICAL AT 3 M

NO.	FREQ. (MHz)	EMISSION LEVEL (dBuV/m)	LIMIT (dBuV/m)	MARGIN (dB)	ANTENNA HEIGHT (m)	TABLE ANGLE (Degree)	RAW VALUE (dBuV)	CORRECTION FACTOR (dB/m)
1	5150.00	68.4 PK	74.0	-5.6	1.72 V	329	60.07	8.33
2	5150.00	53.7 AV	54.0	-0.3	1.72 V	329	45.37	8.33
3	*5190.00	108.4 PK			1.72 V	329	99.90	8.50
4	*5190.00	99.8 AV			1.72 V	329	91.30	8.50
5	5350.00	63.6 PK	74.0	-10.4	1.72 V	329	54.80	8.80
6	5350.00	51.4 AV	54.0	-2.6	1.72 V	329	42.60	8.80
7	#10380.00	55.6 PK	74.0	-18.4	1.08 V	360	41.05	14.55
8	#10380.00	41.6 AV	54.0	-12.4	1.08 V	360	27.05	14.55
9	15570.00	55.7 PK	74.0	-18.3	1.74 V	144	36.91	18.79
10	15570.00	41.8 AV	54.0	-12.2	1.74 V	144	23.01	18.79

REMARKS:

1. Emission Level(dBuV/m) = Raw Value(dBuV) + Correction Factor(dB/m)
2. Correction Factor(dB/m) = Antenna Factor(dB/m) + Cable Factor(dB) – Pre-Amplifier Factor(dB)
3. The other emission levels were very low against the limit.
4. Margin value = Emission Level – Limit value
5. " * ": Fundamental frequency.
6. " # ": The radiated frequency is out of the restricted band.

CHANNEL	TX Channel 46	DETECTOR FUNCTION	Peak (PK)
FREQUENCY RANGE	1GHz ~ 40GHz		Average (AV)

ANTENNA POLARITY & TEST DISTANCE: HORIZONTAL AT 3 M

NO.	FREQ. (MHz)	EMISSION LEVEL (dBuV/m)	LIMIT (dBuV/m)	MARGIN (dB)	ANTENNA HEIGHT (m)	TABLE ANGLE (Degree)	RAW VALUE (dBuV)	CORRECTION FACTOR (dB/m)
1	5150.00	61.4 PK	74.0	-12.6	1.68 H	99	53.07	8.33
2	5150.00	49.5 AV	54.0	-4.5	1.68 H	99	41.17	8.33
3	*5230.00	112.4 PK			1.68 H	99	103.81	8.59
4	*5230.00	101.3 AV			1.68 H	99	92.71	8.59
5	5350.00	62.4 PK	74.0	-11.6	1.68 H	99	53.60	8.80
6	5350.00	52.3 AV	54.0	-1.7	1.68 H	99	43.50	8.80
7	#10460.00	59.6 PK	74.0	-14.4	1.99 H	360	45.09	14.51
8	#10460.00	45.4 AV	54.0	-8.6	1.99 H	360	30.89	14.51
9	15690.00	60.9 PK	74.0	-13.1	1.57 H	295	41.93	18.97
10	15690.00	48.7 AV	54.0	-5.3	1.57 H	295	29.73	18.97

ANTENNA POLARITY & TEST DISTANCE: VERTICAL AT 3 M

NO.	FREQ. (MHz)	EMISSION LEVEL (dBuV/m)	LIMIT (dBuV/m)	MARGIN (dB)	ANTENNA HEIGHT (m)	TABLE ANGLE (Degree)	RAW VALUE (dBuV)	CORRECTION FACTOR (dB/m)
1	5150.00	62.3 PK	74.0	-11.7	1.66 V	334	53.97	8.33
2	5150.00	50.2 AV	54.0	-3.8	1.66 V	334	41.87	8.33
3	*5230.00	113.2 PK			1.66 V	334	104.61	8.59
4	*5230.00	102.1 AV			1.66 V	334	93.51	8.59
5	5350.00	64.5 PK	74.0	-9.5	1.58 V	277	55.70	8.80
6	5350.00	53.4 AV	54.0	-0.6	1.58 V	277	44.60	8.80
7	#10460.00	58.6 PK	74.0	-15.4	1.08 V	360	44.09	14.51
8	#10460.00	44.1 AV	54.0	-9.9	1.08 V	360	29.59	14.51
9	15690.00	59.5 PK	74.0	-14.5	1.75 V	142	40.53	18.97
10	15690.00	46.0 AV	54.0	-8.0	1.75 V	142	27.03	18.97

REMARKS:

1. Emission Level(dBuV/m) = Raw Value(dBuV) + Correction Factor(dB/m)
2. Correction Factor(dB/m) = Antenna Factor(dB/m) + Cable Factor(dB) – Pre-Amplifier Factor(dB)
3. The other emission levels were very low against the limit.
4. Margin value = Emission Level – Limit value
5. " * ": Fundamental frequency.
6. " # ": The radiated frequency is out of the restricted band.

CHANNEL	TX Channel 151	DETECTOR FUNCTION	Peak (PK)
FREQUENCY RANGE	1GHz ~ 40GHz		Average (AV)

ANTENNA POLARITY & TEST DISTANCE: HORIZONTAL AT 3 M

NO.	FREQ. (MHz)	EMISSION LEVEL (dBuV/m)	LIMIT (dBuV/m)	MARGIN (dB)	ANTENNA HEIGHT (m)	TABLE ANGLE (Degree)	RAW VALUE (dBuV)	CORRECTION FACTOR (dB/m)
1	#5715.00	68.5 PK	74.0	-5.5	1.70 H	94	58.82	9.68
2	#5715.00	52.8 AV	54.0	-1.2	1.70 H	94	43.12	9.68
3	#5725.00	71.8 PK	78.2	-6.4	1.70 H	94	62.10	9.70
4	*5755.00	109.7 PK			1.70 H	94	99.93	9.77
5	*5755.00	99.2 AV			1.70 H	94	89.43	9.77
6	#5940.00	61.8 PK	74.0	-12.2	1.68 H	115	51.67	10.13
7	#5940.00	50.1 AV	54.0	-3.9	1.68 H	115	39.97	10.13
8	11510.00	59.8 PK	74.0	-14.2	2.00 H	360	44.95	14.85
9	11510.00	45.3 AV	54.0	-8.7	2.00 H	360	30.45	14.85
10	#17265.00	61.2 PK	74.0	-12.8	1.65 H	277	37.97	23.23
11	#17265.00	48.9 AV	54.0	-5.1	1.65 H	277	25.67	23.23

ANTENNA POLARITY & TEST DISTANCE: VERTICAL AT 3 M

NO.	FREQ. (MHz)	EMISSION LEVEL (dBuV/m)	LIMIT (dBuV/m)	MARGIN (dB)	ANTENNA HEIGHT (m)	TABLE ANGLE (Degree)	RAW VALUE (dBuV)	CORRECTION FACTOR (dB/m)
1	#5715.00	69.7 PK	74.0	-4.3	1.67 V	345	60.02	9.68
2	#5715.00	53.6 AV	54.0	-0.4	1.67 V	345	43.92	9.68
3	#5725.00	72.5 PK	78.2	-5.7	1.67 V	345	62.80	9.70
4	*5755.00	111.1 PK			1.67 V	345	101.33	9.77
5	*5755.00	100.4 AV			1.67 V	345	90.63	9.77
6	#5940.00	62.4 PK	74.0	-11.6	1.63 V	289	52.27	10.13
7	#5940.00	50.3 AV	54.0	-3.7	1.63 V	289	40.17	10.13
8	11510.00	58.8 PK	74.0	-15.2	1.16 V	360	43.95	14.85
9	11510.00	44.1 AV	54.0	-9.9	1.16 V	360	29.25	14.85
10	#17265.00	59.0 PK	74.0	-15.0	1.85 V	172	35.77	23.23
11	#17265.00	45.5 AV	54.0	-8.5	1.85 V	172	22.27	23.23

REMARKS:

1. Emission Level(dBuV/m) = Raw Value(dBuV) + Correction Factor(dB/m)
2. Correction Factor(dB/m) = Antenna Factor(dB/m) + Cable Factor(dB) – Pre-Amplifier Factor(dB)
3. The other emission levels were very low against the limit.
4. Margin value = Emission Level – Limit value
5. " * ": Fundamental frequency.
6. " # ": The radiated frequency is out of the restricted band.

CHANNEL	TX Channel 159	DETECTOR FUNCTION	Peak (PK)
FREQUENCY RANGE	1GHz ~ 40GHz		Average (AV)

ANTENNA POLARITY & TEST DISTANCE: HORIZONTAL AT 3 M

NO.	FREQ. (MHz)	EMISSION LEVEL (dBuV/m)	LIMIT (dBuV/m)	MARGIN (dB)	ANTENNA HEIGHT (m)	TABLE ANGLE (Degree)	RAW VALUE (dBuV)	CORRECTION FACTOR (dB/m)
1	#5715.00	66.8 PK	68.2	-1.4	1.66 H	96	57.12	9.68
2	*5795.00	113.3 PK			1.66 H	96	103.42	9.88
3	*5795.00	102.4 AV			1.66 H	96	92.52	9.88
4	#5860.00	67.2 PK	68.2	-1.0	1.66 H	96	57.27	9.93
5	11590.00	59.5 PK	74.0	-14.5	1.97 H	360	44.19	15.31
6	11590.00	44.9 AV	54.0	-9.1	1.97 H	360	29.59	15.31
7	#17385.00	61.0 PK	74.0	-13.0	1.60 H	276	37.24	23.76
8	#17385.00	49.0 AV	54.0	-5.0	1.60 H	276	25.24	23.76

ANTENNA POLARITY & TEST DISTANCE: VERTICAL AT 3 M

NO.	FREQ. (MHz)	EMISSION LEVEL (dBuV/m)	LIMIT (dBuV/m)	MARGIN (dB)	ANTENNA HEIGHT (m)	TABLE ANGLE (Degree)	RAW VALUE (dBuV)	CORRECTION FACTOR (dB/m)
1	#5715.00	64.6 PK	68.2	-3.6	1.64 V	330	54.92	9.68
2	*5795.00	114.6 PK			1.64 V	330	104.72	9.88
3	*5795.00	103.3 AV			1.64 V	330	93.42	9.88
4	#5850.00	70.5 PK	78.2	-7.7	1.64 V	330	60.58	9.92
5	#5860.00	67.9 PK	68.2	-0.3	1.64 V	330	57.97	9.93
6	11590.00	59.1 PK	74.0	-14.9	1.18 V	360	43.79	15.31
7	11590.00	44.4 AV	54.0	-9.6	1.18 V	360	29.09	15.31
8	#17385.00	59.4 PK	74.0	-14.6	1.82 V	161	35.64	23.76
9	#17385.00	45.9 AV	54.0	-8.1	1.82 V	161	22.14	23.76

REMARKS:

1. Emission Level(dBuV/m) = Raw Value(dBuV) + Correction Factor(dB/m)
2. Correction Factor(dB/m) = Antenna Factor(dB/m) + Cable Factor(dB) – Pre-Amplifier Factor(dB)
3. The other emission levels were very low against the limit.
4. Margin value = Emission Level – Limit value
5. " * ": Fundamental frequency.
6. " # ": The radiated frequency is out of the restricted band.

802.11ac (VHT80)

CHANNEL	TX Channel 42	DETECTOR FUNCTION	Peak (PK)
FREQUENCY RANGE	1GHz ~ 40GHz		Average (AV)

ANTENNA POLARITY & TEST DISTANCE: HORIZONTAL AT 3 M

NO.	FREQ. (MHz)	EMISSION LEVEL (dBuV/m)	LIMIT (dBuV/m)	MARGIN (dB)	ANTENNA HEIGHT (m)	TABLE ANGLE (Degree)	RAW VALUE (dBuV)	CORRECTION FACTOR (dB/m)
1	5150.00	67.5 PK	74.0	-6.5	1.60 H	52	59.17	8.33
2	5150.00	53.5 AV	54.0	-0.5	1.60 H	52	45.17	8.33
3	*5210.00	114.2 PK			1.60 H	52	105.65	8.55
4	*5210.00	93.0 AV			1.60 H	52	84.45	8.55
5	5350.00	57.4 PK	74.0	-16.6	1.60 H	52	48.60	8.80
6	5350.00	44.2 AV	54.0	-9.8	1.60 H	52	35.40	8.80
7	#10420.00	59.2 PK	74.0	-14.8	1.92 H	360	44.63	14.57
8	#10420.00	44.5 AV	54.0	-9.5	1.92 H	360	29.93	14.57
9	15630.00	61.4 PK	74.0	-12.6	1.54 H	268	42.47	18.93
10	15630.00	49.4 AV	54.0	-4.6	1.54 H	268	30.47	18.93

ANTENNA POLARITY & TEST DISTANCE: VERTICAL AT 3 M

NO.	FREQ. (MHz)	EMISSION LEVEL (dBuV/m)	LIMIT (dBuV/m)	MARGIN (dB)	ANTENNA HEIGHT (m)	TABLE ANGLE (Degree)	RAW VALUE (dBuV)	CORRECTION FACTOR (dB/m)
1	5150.00	67.8 PK	74.0	-6.2	1.65 V	335	59.47	8.33
2	5150.00	53.7 AV	54.0	-0.3	1.65 V	335	45.37	8.33
3	*5210.00	114.7 PK			1.65 V	335	106.15	8.55
4	*5210.00	93.6 AV			1.65 V	335	85.05	8.55
5	5350.00	58.7 PK	74.0	-15.3	1.65 V	335	49.90	8.80
6	5350.00	44.5 AV	54.0	-9.5	1.65 V	335	35.70	8.80
7	#10420.00	59.3 PK	74.0	-14.7	1.20 V	360	44.73	14.57
8	#10420.00	44.6 AV	54.0	-9.4	1.20 V	360	30.03	14.57
9	15630.00	58.9 PK	74.0	-15.1	1.76 V	149	39.97	18.93
10	15630.00	45.6 AV	54.0	-8.4	1.76 V	149	26.67	18.93

REMARKS:

1. Emission Level(dBuV/m) = Raw Value(dBuV) + Correction Factor(dB/m)
2. Correction Factor(dB/m) = Antenna Factor(dB/m) + Cable Factor(dB) – Pre-Amplifier Factor(dB)
3. The other emission levels were very low against the limit.
4. Margin value = Emission Level – Limit value
5. " * ": Fundamental frequency.
6. " # ": The radiated frequency is out of the restricted band.

CHANNEL	TX Channel 155	DETECTOR FUNCTION	Peak (PK)
FREQUENCY RANGE	1GHz ~ 40GHz		Average (AV)

ANTENNA POLARITY & TEST DISTANCE: HORIZONTAL AT 3 M

NO.	FREQ. (MHz)	EMISSION LEVEL (dBuV/m)	LIMIT (dBuV/m)	MARGIN (dB)	ANTENNA HEIGHT (m)	TABLE ANGLE (Degree)	RAW VALUE (dBuV)	CORRECTION FACTOR (dB/m)
1	#5715.00	68.3 PK	74.0	-5.7	1.58 H	59	58.62	9.68
2	#5715.00	53.6 AV	54.0	-0.4	1.58 H	59	43.92	9.68
3	#5725.00	72.8 PK	78.2	-5.4	1.58 H	59	63.10	9.70
4	*5775.00	106.3 PK			1.58 H	59	96.47	9.83
5	*5775.00	94.8 AV			1.58 H	59	84.97	9.83
6	#5850.00	62.5 PK	78.2	-15.7	1.58 H	59	52.58	9.92
7	#5860.00	61.1 PK	74.0	-12.9	1.58 H	59	51.17	9.93
8	#5860.00	49.4 AV	54.0	-4.6	1.58 H	59	39.47	9.93
9	11550.00	59.4 PK	74.0	-14.6	1.89 H	360	44.31	15.09
10	11550.00	44.7 AV	54.0	-9.3	1.89 H	360	29.61	15.09
11	#17325.00	61.4 PK	74.0	-12.6	1.54 H	267	38.02	23.38
12	#17325.00	49.7 AV	54.0	-4.3	1.54 H	267	26.32	23.38

ANTENNA POLARITY & TEST DISTANCE: VERTICAL AT 3 M

NO.	FREQ. (MHz)	EMISSION LEVEL (dBuV/m)	LIMIT (dBuV/m)	MARGIN (dB)	ANTENNA HEIGHT (m)	TABLE ANGLE (Degree)	RAW VALUE (dBuV)	CORRECTION FACTOR (dB/m)
1	#5715.00	69.6 PK	74.0	-4.4	1.69 V	338	59.92	9.68
2	#5715.00	53.8 AV	54.0	-0.2	1.69 V	338	44.12	9.68
3	#5725.00	73.1 PK	78.2	-5.1	1.69 V	338	63.40	9.70
4	*5775.00	107.4 PK			1.69 V	338	97.57	9.83
5	*5775.00	95.7 AV			1.69 V	338	85.87	9.83
6	#5850.00	64.2 PK	78.2	-14.0	1.69 V	338	54.28	9.92
7	#5860.00	62.4 PK	74.0	-11.6	1.69 V	338	52.47	9.93
8	#5860.00	49.3 AV	54.0	-4.7	1.69 V	338	39.37	9.93
9	11550.00	59.2 PK	74.0	-14.8	1.17 V	360	44.11	15.09
10	11550.00	44.3 AV	54.0	-9.7	1.17 V	360	29.21	15.09
11	#17325.00	59.2 PK	74.0	-14.8	1.79 V	152	35.82	23.38
12	#17325.00	45.7 AV	54.0	-8.3	1.79 V	152	22.32	23.38

REMARKS:

1. Emission Level(dBuV/m) = Raw Value(dBuV) + Correction Factor(dB/m)
2. Correction Factor(dB/m) = Antenna Factor(dB/m) + Cable Factor(dB) – Pre-Amplifier Factor(dB)
3. The other emission levels were very low against the limit.
4. Margin value = Emission Level – Limit value
5. " * ": Fundamental frequency.
6. " # ": The radiated frequency is out of the restricted band.

4.2 Conducted Emission Measurement

4.2.1 Limits of Conducted Emission Measurement

Frequency (MHz)	Conducted Limit (dBuV)	
	Quasi-peak	Average
0.15 - 0.5	66 - 56	56 - 46
0.50 - 5.0	56	46
5.0 - 30.0	60	50

- Note: 1. The lower limit shall apply at the transition frequencies.
 2. The limit decreases in line with the logarithm of the frequency in the range of 0.15 to 0.50MHz.

4.2.2 Test Instruments

DESCRIPTION & MANUFACTURER	MODEL NO.	SERIAL NO.	CALIBRATED DATE	CALIBRATED UNTIL
Test Receiver R&S	ESCS 30	100375	May 06, 2015	May 05, 2016
Line-Impedance Stabilization Network (for EUT) R&S	ENV216	100072	June 11, 2015	June 10, 2016
Line-Impedance Stabilization Network (for Peripheral) R&S	ENV216	100071	Nov. 10, 2014	Nov. 09, 2015
RF Cable	5D-FB	COCCAB-001	Mar. 09, 2015	Mar. 08, 2016
50 ohms Terminator	N/A	EMC-03	Sep. 22, 2014	Sep. 21, 2015
50 ohms Terminator	N/A	EMC-02	Sep. 30, 2014	Sep. 29, 2015
Software BVADT	BVADT_Cond_ V7.3.7.3	NA	NA	NA

Note:

1. The calibration interval of the above test instruments are 12 months and the calibrations are traceable to NML/ROC and NIST/USA.
2. The test was performed in Shielded Room No. C.
3. The VCCI Con C Registration No. is C-3611.
4. Tested Date: Sep. 10, 2015

4.2.3 Test Procedure

- a. The EUT was placed 0.4 meters from the conducting wall of the shielded room with EUT being connected to the power mains through a line impedance stabilization network (LISN). Other support units were connected to the power mains through another LISN. The two LISNs provide 50 ohm/ 50uH of coupling impedance for the measuring instrument.
- b. Both lines of the power mains connected to the EUT were checked for maximum conducted interference.
- c. The frequency range from 150kHz to 30MHz was searched. Emission levels under (Limit - 20dB) was not recorded.

NOTE: All modes of operation were investigated and the worst-case emissions are reported.

4.2.4 Deviation from Test Standard

No deviation.

4.2.5 Test Setup

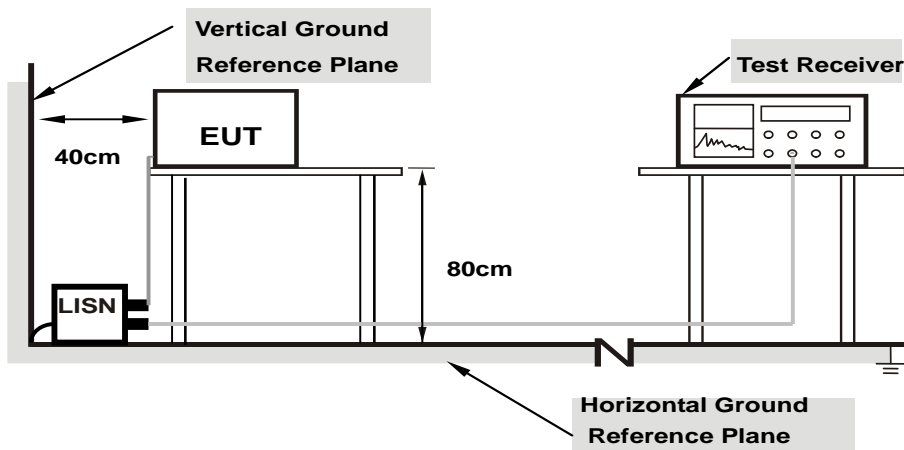

Note: 1.Support units were connected to second LISN.

For the actual test configuration, please refer to the attached file (Test Setup Photo).

4.2.6 EUT Operating Condition

Same as 4.1.6.

4.2.7 Test Results

CDD Mode

Phase	Line (L)	Detector Function	Quasi-Peak (QP) / Average (AV)
-------	----------	-------------------	--------------------------------

No	Freq. [MHz]	Corr.	Reading Value		Emission Level		Limit		Margin	
		Factor	[dB (uV)]		[dB (uV)]		[dB (uV)]		(dB)	
	(dB)	Q.P.	AV.	Q.P.	AV.	Q.P.	AV.	Q.P.	AV.	
1	0.30234	0.10	56.78	47.76	56.88	47.86	60.18	50.18	-3.30	-2.32
2	0.32578	0.10	54.66	43.06	54.76	43.16	59.56	49.56	-4.80	-6.40
3	0.45078	0.10	48.13	38.92	48.23	39.02	56.86	46.86	-8.63	-7.84
4	0.48984	0.10	48.84	38.69	48.94	38.79	56.17	46.17	-7.23	-7.38
5	0.72031	0.12	45.73	34.81	45.85	34.93	56.00	46.00	-10.15	-11.07
6	0.79453	0.12	47.29	35.94	47.41	36.06	56.00	46.00	-8.59	-9.94
7	0.94688	0.13	41.38	30.18	41.51	30.31	56.00	46.00	-14.49	-15.69
8	1.04688	0.13	46.21	36.02	46.34	36.15	56.00	46.00	-9.66	-9.85
9	1.35938	0.14	43.20	33.87	43.34	34.01	56.00	46.00	-12.66	-11.99

REMARKS:

1. Q.P. and AV. are abbreviations of quasi-peak and average individually.
2. The emission levels of other frequencies were very low against the limit.
3. Margin value = Emission level - Limit value
4. Correction factor = Insertion loss + Cable loss
5. Emission Level = Correction Factor + Reading Value

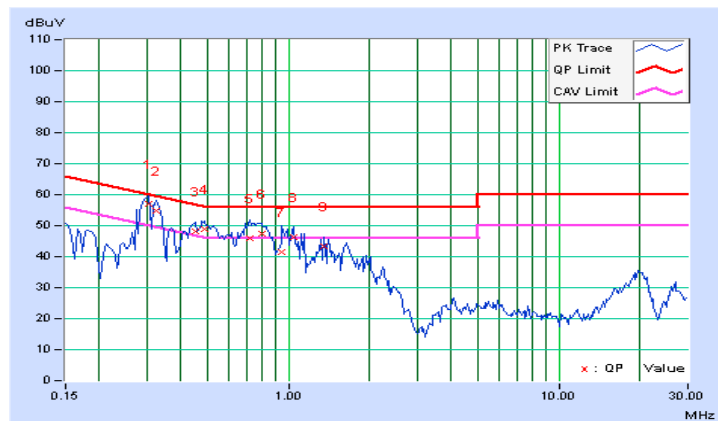

Phase	Neutral (N)	Detector Function	Quasi-Peak (QP) / Average (AV)
-------	-------------	-------------------	--------------------------------

No	Freq. [MHz]	Corr.	Reading Value		Emission Level		Limit		Margin	
		Factor	[dB (uV)]		[dB (uV)]		[dB (uV)]		(dB)	
		(dB)	Q.P.	AV.	Q.P.	AV.	Q.P.	AV.	Q.P.	AV.
1	0.30234	0.09	56.72	47.09	56.81	47.18	60.18	50.18	-3.37	-3.00
2	0.32578	0.09	54.74	43.48	54.83	43.57	59.56	49.56	-4.73	-5.99
3	0.37266	0.10	46.58	39.11	46.68	39.21	58.44	48.44	-11.76	-9.23
4	0.49375	0.10	47.83	35.63	47.93	35.73	56.10	46.10	-8.17	-10.37
5	0.60313	0.11	42.77	30.83	42.88	30.94	56.00	46.00	-13.12	-15.06
6	0.72422	0.12	45.55	34.44	45.67	34.56	56.00	46.00	-10.33	-11.44
7	0.99375	0.13	44.47	34.09	44.60	34.22	56.00	46.00	-11.40	-11.78
8	1.11328	0.13	43.50	33.06	43.63	33.19	56.00	46.00	-12.37	-12.81
9	1.35938	0.14	43.10	33.47	43.24	33.61	56.00	46.00	-12.76	-12.39

REMARKS:

1. Q.P. and AV. are abbreviations of quasi-peak and average individually.
2. The emission levels of other frequencies were very low against the limit.
3. Margin value = Emission level - Limit value
4. Correction factor = Insertion loss + Cable loss
5. Emission Level = Correction Factor + Reading Value

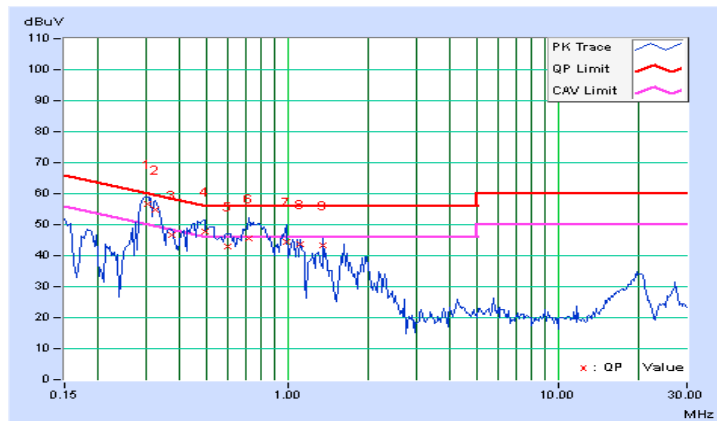

4.3 Transmit Power Measurement

4.3.1 Limits of Transmit Power Measurement

Operation Band	EUT Category		LIMIT
U-NII-1		Outdoor Access Point	1 Watt (30 dBm) (Max. e.i.r.p \leq 125mW(21 dBm) at any elevation angle above 30 degrees as measured from the horizon)
		Fixed point-to-point Access Point	1 Watt (30 dBm)
	√	Indoor Access Point	1 Watt (30 dBm)
		Mobile and Portable client device	250mW (24 dBm)
U-NII-2A			250mW (24 dBm) or 11 dBm+10 log B*
U-NII-2C			250mW (24 dBm) or 11 dBm+10 log B*
U-NII-3	√		1 Watt (30 dBm)

*B is the 26 dB emission bandwidth in megahertz

Per KDB 662911 Method of conducted output power measurement on IEEE 802.11 devices,

Array Gain = 0 dB (i.e., no array gain) for $N_{ANT} \leq 4$;

Array Gain = 0 dB (i.e., no array gain) for channel widths ≥ 40 MHz for any N_{ANT} ;

Array Gain = $5 \log(N_{ANT}/N_{SS})$ dB or 3 dB, whichever is less for 20-MHz channel widths with $N_{ANT} \geq 5$.

For power measurements on all other devices: Array Gain = $10 \log(N_{ANT}/N_{SS})$ dB.

4.3.2 Test Setup

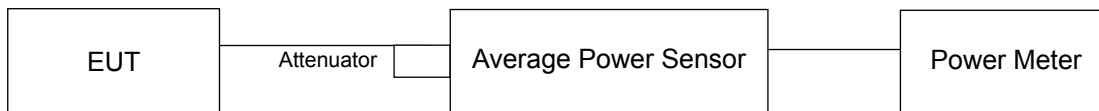

4.3.3 Test Instruments

Refer to section 4.1.2 to get information of above instrument.

4.3.4 Test Procedure

Method PM is used to perform output power measurement, trigger and gating function of wide band power meter is enabled to measure max output power of TX on burst. Duty factor is not added to measured value.

4.3.5 Deviation from Test Standard

No deviation.

4.3.6 EUT Operating Condition

The software provided by client to enable the EUT under transmission condition continuously at lowest, middle and highest channel frequencies individually.

4.3.7 Test Result

CDD Mode

802.11a

Chan.	Chan. Freq. (MHz)	Average Power (dBm)			Total Power (mW)	Total Power (dBm)	Limit (dBm)	Pass / Fail
		Chain 0	Chain 1	Chain 2				
36	5180	21.68	21.69	21.55	437.691	26.41	30	Pass
40	5200	22.09	21.71	21.39	447.781	26.51	30	Pass
48	5240	21.98	21.57	21.66	447.865	26.51	30	Pass
149	5745	19.96	20.36	20.42	317.88	25.02	30	Pass
157	5785	19.52	19.85	19.79	281.421	24.49	30	Pass
165	5825	19.10	19.76	19.45	264.012	24.22	30	Pass

802.11ac (VHT20)

Chan.	Chan. Freq. (MHz)	Average Power (dBm)			Total Power (mW)	Total Power (dBm)	Limit (dBm)	Pass / Fail
		Chain 0	Chain 1	Chain 2				
36	5180	21.30	20.94	20.84	380.4	25.80	30	Pass
40	5200	21.96	20.85	20.54	391.895	25.93	30	Pass
48	5240	21.91	20.94	20.52	392.124	25.93	30	Pass
149	5745	19.29	19.20	18.10	232.659	23.67	30	Pass
157	5785	18.91	19.14	17.95	222.212	23.47	30	Pass
165	5825	18.33	18.98	18.12	212.008	23.26	30	Pass

802.11ac (VHT40)

Chan.	Chan. Freq. (MHz)	Average Power (dBm)			Total Power (mW)	Total Power (dBm)	Limit (dBm)	Pass / Fail
		Chain 0	Chain 1	Chain 2				
38	5190	18.07	18.13	18.47	199.441	23.00	30	Pass
46	5230	22.14	21.77	21.98	471.757	26.74	30	Pass
151	5755	18.95	19.47	19.53	256.779	24.10	30	Pass
159	5795	22.76	23.39	23.11	611.716	27.87	30	Pass

802.11ac (VHT80)

Chan.	Chan. Freq. (MHz)	Average Power (dBm)			Total Power (mW)	Total Power (dBm)	Limit (dBm)	Pass / Fail
		Chain 0	Chain 1	Chain 2				
42	5210	16.35	16.70	16.85	138.343	21.41	30	Pass
155	5775	17.55	18.52	18.30	195.614	22.91	30	Pass

Beamforming Mode

802.11ac (VHT20)

Chan.	Chan. Freq. (MHz)	Average Power (dBm)			Total Power (mW)	Total Power (dBm)	Limit (dBm)	Pass / Fail
		Chain 0	Chain 1	Chain 2				
36	5180	20.60	20.20	20.02	319.99	25.05	26.03	Pass
40	5200	21.86	20.67	20.33	378.038	25.78	26.03	Pass
48	5240	21.84	20.55	20.36	374.901	25.74	26.03	Pass
149	5745	18.17	18.11	17.15	182.209	22.61	26.03	Pass
157	5785	18.05	18.02	16.98	177.101	22.48	26.03	Pass
165	5825	17.52	17.87	17.09	168.897	22.28	26.03	Pass

Note: Directional gain = $5.2\text{dBi} + 10\log(3) = 9.97\text{dBi} > 6\text{dBi}$, so the power limit shall be reduced to $30-(9.97-6) = 26.03\text{dBm}$.

802.11ac (VHT40)

Chan.	Chan. Freq. (MHz)	Average Power (dBm)			Total Power (mW)	Total Power (dBm)	Limit (dBm)	Pass / Fail
		Chain 0	Chain 1	Chain 2				
38	5190	15.81	15.83	16.16	117.694	20.71	26.03	Pass
46	5230	20.38	20.03	20.20	314.55	24.98	26.03	Pass
151	5755	17.14	17.69	17.77	170.351	22.31	26.03	Pass
159	5795	20.87	21.36	21.12	388.373	25.89	26.03	Pass

Note: Directional gain = $5.2\text{dBi} + 10\log(3) = 9.97\text{dBi} > 6\text{dBi}$, so the power limit shall be reduced to $30-(9.97-6) = 26.03\text{dBm}$.

802.11ac (VHT80)

Chan.	Chan. Freq. (MHz)	Average Power (dBm)			Total Power (mW)	Total Power (dBm)	Limit (dBm)	Pass / Fail
		Chain 0	Chain 1	Chain 2				
42	5210	14.41	14.79	14.88	88.497	19.47	26.03	Pass
155	5775	15.74	16.76	16.61	130.735	21.16	26.03	Pass

Note: Directional gain = $5.2\text{dBi} + 10\log(3) = 9.97\text{dBi} > 6\text{dBi}$, so the power limit shall be reduced to $30-(9.97-6) = 26.03\text{dBm}$.

4.4 Peak Power Spectral Density Measurement

4.4.1 Limits of Peak Power Spectral Density Measurement

Operation Band	EUT Category		LIMIT
U-NII-1		Outdoor Access Point	17dBm/ MHz
		Fixed point-to-point Access Point	
	√	Indoor Access Point	
		Mobile and Portable client device	11dBm/ MHz
U-NII-2A			11dBm/ MHz
U-NII-2C			11dBm/ MHz
U-NII-3	√		30dBm/ 500kHz

4.4.2 Test Setup

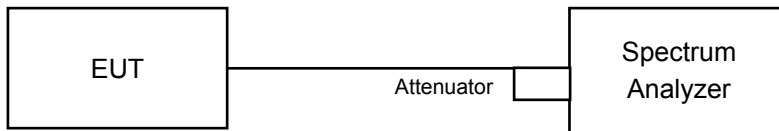

4.4.3 Test Instruments

Refer to section 4.1.2 to get information of above instrument.

4.4.4 Test Procedure

For U-NII-1 band:

For 802.11a, 802.11ac (VHT20), 802.11ac (VHT40):

Using method SA-1

- a. Set span to encompass the entire emission bandwidth (EBW) of the signal.
- b. Set RBW = 1 MHz, Set VBW \geq 3 MHz, Detector = RMS
- c. Sweep time = auto, trigger set to "free run".
- d. Trace average at least 100 traces in power averaging mode.
- e. Record the max value

For 802.11ac (VHT80):

Using method SA-2

- a. Set span to encompass the entire emission bandwidth (EBW) of the signal.
- b. Set RBW = 1 MHz, Set VBW \geq 3 MHz, Detector = RMS
- c. Sweep time = auto, trigger set to "free run".
- d. Trace average at least 100 traces in power averaging mode.
- e. Record the max value and add 10 log (1/duty cycle)

For U-NII-3 band:

For 802.11a, 802.11ac (VHT20), 802.11ac (VHT40):

1. Set span to encompass the entire emission bandwidth (EBW) of the signal.
2. Set RBW = 300 kHz, Set VBW \geq 1 MHz, Detector = RMS
3. Use the peak marker function to determine the maximum power level in any 300 kHz band segment within the fundamental EBW.
4. Scale the observed power level to an equivalent value in 500 kHz by adjusting (reducing) the measured power by a bandwidth correction factor (BWCF) where $BWCF = 10\log(500 \text{ kHz}/300\text{kHz})$
5. Sweep time = auto, trigger set to "free run".
6. Trace average at least 100 traces in power averaging mode.
7. Record the max value

For 802.11ac (VHT80):

1. Set span to encompass the entire emission bandwidth (EBW) of the signal.
2. Set RBW = 300 kHz, Set VBW \geq 1 MHz, Detector = RMS
3. Use the peak marker function to determine the maximum power level in any 300 kHz band segment within the fundamental EBW.
4. Scale the observed power level to an equivalent value in 500 kHz by adjusting (reducing) the measured power by a bandwidth correction factor (BWCF) where $BWCF = 10\log(500 \text{ kHz}/300\text{kHz})$
5. Sweep time = auto, trigger set to "free run".
6. Trace average at least 100 traces in power averaging mode.
7. Record the max value and add 10 log (1/duty cycle)

4.4.5 Deviation from Test Standard

No deviation.

4.4.6 EUT Operating Condition

Same as Item 4.3.6.

4.4.7 Test Results

CDD Mode

802.11a

Chan.	Chan. Freq. (MHz)	PSD (dBm)			Total Power Density (dBm)	MAX. Limit (dBm)	Pass / Fail
		Chain 0	Chain 1	Chain 2			
36	5180	7.46	7.05	7.26	12.03	13.03	Pass
40	5200	7.55	7.12	7.30	12.10	13.03	Pass
48	5240	7.82	7.38	7.46	12.33	13.03	Pass

- Note:**
- Method a) of power density measurement of KDB 662911 is using for calculating total power density. Total power density is summing entire spectra across corresponding frequency bins on the various outputs by computer.
 - Directional gain = $5.2\text{dBi} + 10\log(3) = 9.97\text{dBi} > 6\text{dBi}$, so the power density limit shall be reduced to $17-(9.97-6) = 13.03\text{dBm}$.

802.11ac (VHT20)

Chan.	Chan. Freq. (MHz)	PSD (dBm)			Total Power Density (dBm)	MAX. Limit (dBm)	Pass / Fail
		Chain 0	Chain 1	Chain 2			
36	5180	7.46	6.91	6.80	11.84	13.03	Pass
40	5200	7.56	6.99	6.93	11.94	13.03	Pass
48	5240	7.63	7.54	7.04	12.18	13.03	Pass

- Note:**
- Method a) of power density measurement of KDB 662911 is using for calculating total power density. Total power density is summing entire spectra across corresponding frequency bins on the various outputs by computer.
 - Directional gain = $5.2\text{dBi} + 10\log(3) = 9.97\text{dBi} > 6\text{dBi}$, so the power density limit shall be reduced to $17-(9.97-6) = 13.03\text{dBm}$.

802.11ac (VHT40)

Chan.	Chan. Freq. (MHz)	PSD (dBm)			Total Power Density (dBm)	MAX. Limit (dBm)	Pass / Fail
		Chain 0	Chain 1	Chain 2			
38	5190	1.65	1.40	1.41	6.26	13.03	Pass
46	5230	6.11	5.65	5.49	10.53	13.03	Pass

- Note:**
- Method a) of power density measurement of KDB 662911 is using for calculating total power density. Total power density is summing entire spectra across corresponding frequency bins on the various outputs by computer.
 - Directional gain = $5.2\text{dBi} + 10\log(3) = 9.97\text{dBi} > 6\text{dBi}$, so the power density limit shall be reduced to $17-(9.97-6) = 13.03\text{dBm}$.

802.11ac (VHT80)

Chan.	Chan. Freq. (MHz)	PSD W/O Duty Factor (dBm)			Duty Factor (dB)	Total PSD With Duty Factor (dBm)	MAX. Limit (dBm)	Pass / Fail
		Chain 0	Chain 1	Chain 2				
42	5210	-2.99	-2.94	-2.76	0.27	2.15	13.03	Pass

- Note:**
- Method a) of power density measurement of KDB 662911 is using for calculating total power density. Total power density is summing entire spectra across corresponding frequency bins on the various outputs by computer.
 - Directional gain = $5.2\text{dBi} + 10\log(3) = 9.97\text{dBi} > 6\text{dBi}$, so the power density limit shall be reduced to $17-(9.97-6) = 13.03\text{dBm}$.
 - Refer to section 3.3 for duty cycle spectrum plot.

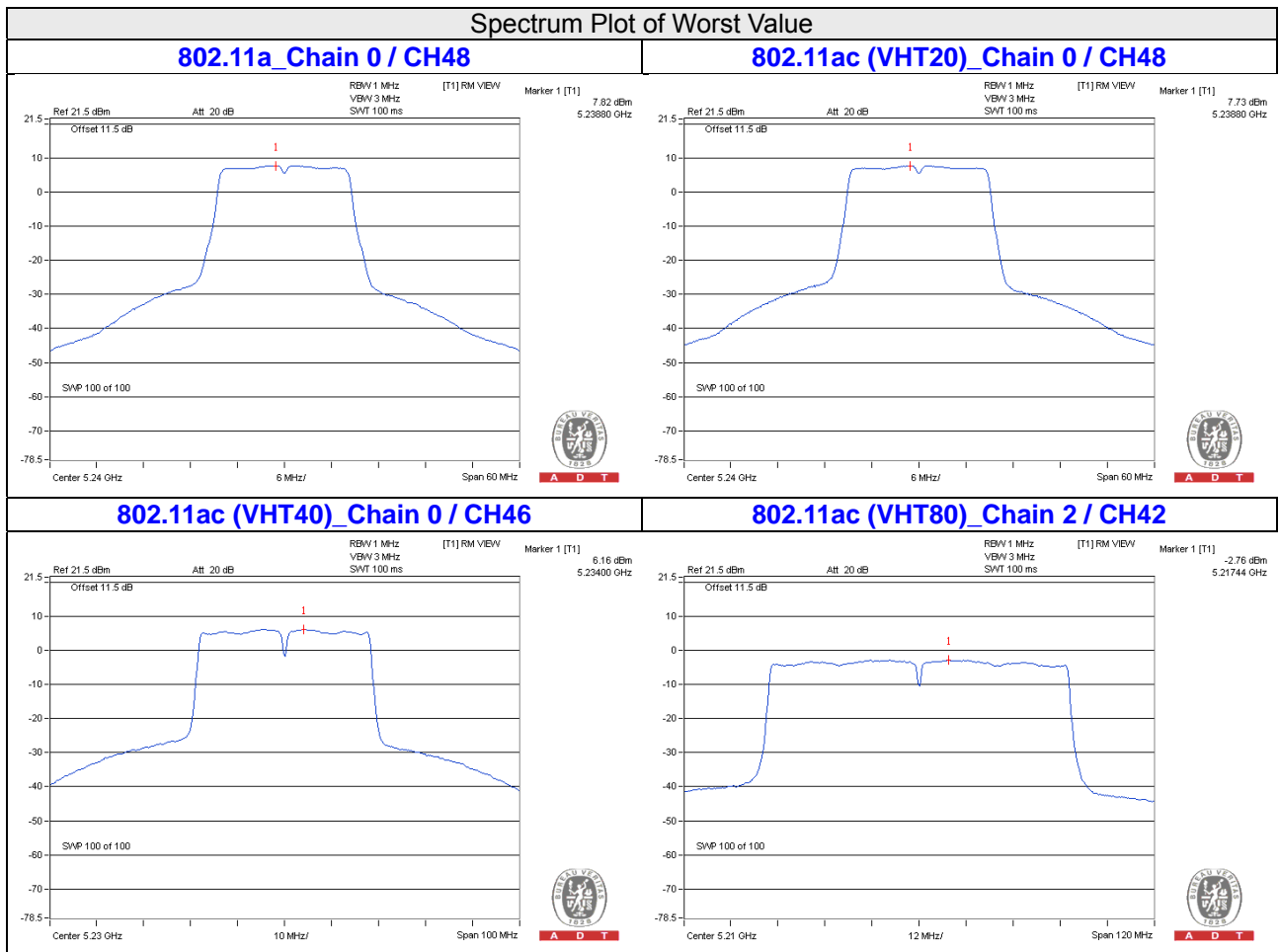

For U-NII-3:
CDD Mode
802.11a

TX chain	Channel	Freq. (MHz)	PSD (dBm/300kHz)	PSD (dBm/500kHz)	10 log (N=3) dB	Total PSD (dBm/500kHz)	Limit (dBm/500kHz)	Pass /Fail
0	149	5745	-1.10	1.12	4.77	5.89	26.03	Pass
	157	5785	-1.62	0.60	4.77	5.37	26.03	Pass
	165	5825	-1.89	0.33	4.77	5.10	26.03	Pass
1	149	5745	-1.33	0.89	4.77	5.66	26.03	Pass
	157	5785	-1.63	0.59	4.77	5.36	26.03	Pass
	165	5825	-1.69	0.53	4.77	5.30	26.03	Pass
2	149	5745	-1.65	0.57	4.77	5.34	26.03	Pass
	157	5785	-2.17	0.05	4.77	4.82	26.03	Pass
	165	5825	-2.12	0.10	4.77	4.87	26.03	Pass

Note: 1. Directional gain = 5.2dBi + 10log(3) = 9.97dBi > 6dBi , so the power density limit shall be reduced to 30-(9.97-6) = 26.03dBm.

802.11ac (VHT20)

TX chain	Channel	Freq. (MHz)	PSD (dBm/300kHz)	PSD (dBm/500kHz)	10 log (N=3) dB	Total PSD (dBm/500kHz)	Limit (dBm/500kHz)	Pass /Fail
0	149	5745	-2.41	-0.19	4.77	4.58	26.03	Pass
	157	5785	-2.53	-0.31	4.77	4.46	26.03	Pass
	165	5825	-2.55	-0.33	4.77	4.44	26.03	Pass
1	149	5745	-2.40	-0.18	4.77	4.59	26.03	Pass
	157	5785	-2.40	-0.18	4.77	4.59	26.03	Pass
	165	5825	-2.81	-0.59	4.77	4.18	26.03	Pass
2	149	5745	-2.56	-0.34	4.77	4.43	26.03	Pass
	157	5785	-2.68	-0.46	4.77	4.31	26.03	Pass
	165	5825	-2.88	-0.66	4.77	4.11	26.03	Pass

Note: 1. Directional gain = 5.2dBi + 10log(3) = 9.97dBi > 6dBi , so the power density limit shall be reduced to 30-(9.97-6) = 26.03dBm.

802.11ac (VHT40)

TX chain	Channel	Freq. (MHz)	PSD (dBm/300kHz)	PSD (dBm/500kHz)	10 log (N=3) dB	Total PSD (dBm/500kHz)	Limit (dBm/500kHz)	Pass /Fail
0	151	5755	-5.48	-3.26	4.77	1.51	26.03	Pass
	159	5795	-1.56	0.66	4.77	5.43	26.03	Pass
1	151	5755	-5.29	-3.07	4.77	1.70	26.03	Pass
	159	5795	-1.61	0.61	4.77	5.38	26.03	Pass
2	151	5755	-5.45	-3.23	4.77	1.54	26.03	Pass
	159	5795	-1.93	0.29	4.77	5.06	26.03	Pass

Note: 1. Directional gain = 5.2dBi + 10log(3) = 9.97dBi > 6dBi , so the power density limit shall be reduced to 30-(9.97-6) = 26.03dBm.

802.11ac (VHT80)

TX chain	Chan.	Chan. Freq. (MHz)	PSD W/O Duty Factor		10 log (N=3) dB	Duty Factor (dB)	Total PSD With Duty Factor (dBm/500kHz)	Limit (dBm/500kHz)	Pass /Fail
			(dBm/300kHz)	(dBm/500kHz)					
0	155	5775	-10.32	-8.10	4.77	0.27	-3.06	26.03	Pass
1	155	5775	-10.32	-8.10	4.77	0.27	-3.06	26.03	Pass
2	155	5775	-9.55	-7.33	4.77	0.27	-2.29	26.03	Pass

Note: 1. Directional gain = 5.2dBi + 10log(3) = 9.97dBi > 6dBi , so the power density limit shall be reduced to 30-(9.97-6) = 26.03dBm.

2. Refer to section 3.3 for duty cycle spectrum plot.

Spectrum Plot of Worst Value

802.11a – Chain 0: CH 149

802.11ac (VHT20) – Chain 1: CH 149

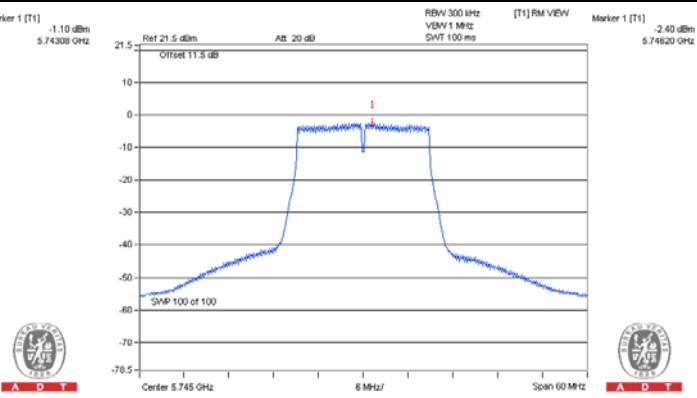
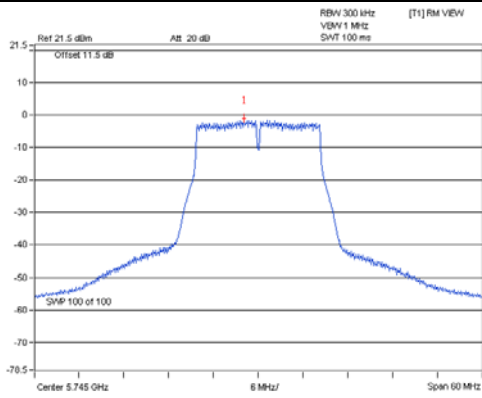

802.11ac (VHT40) – Chain 0: CH 159

802.11ac (VHT80) – Chain 2: CH 155

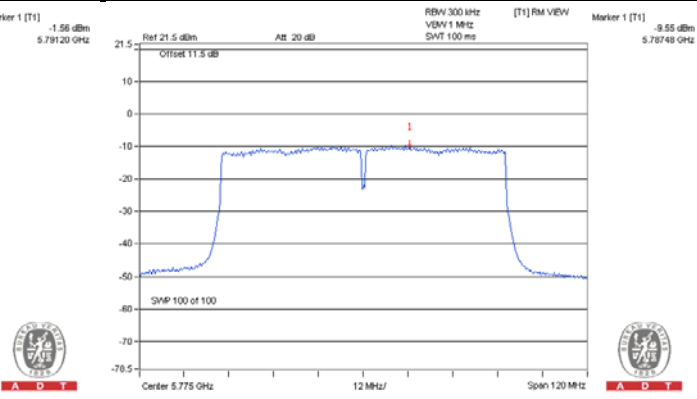
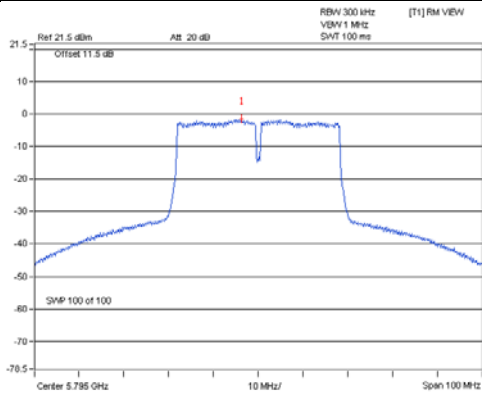

4.5 Frequency Stability Measurement

4.5.1 Limits of Frequency Stability Measurement

The frequency of the carrier signal shall be maintained within band of operation

4.5.2 Test Setup

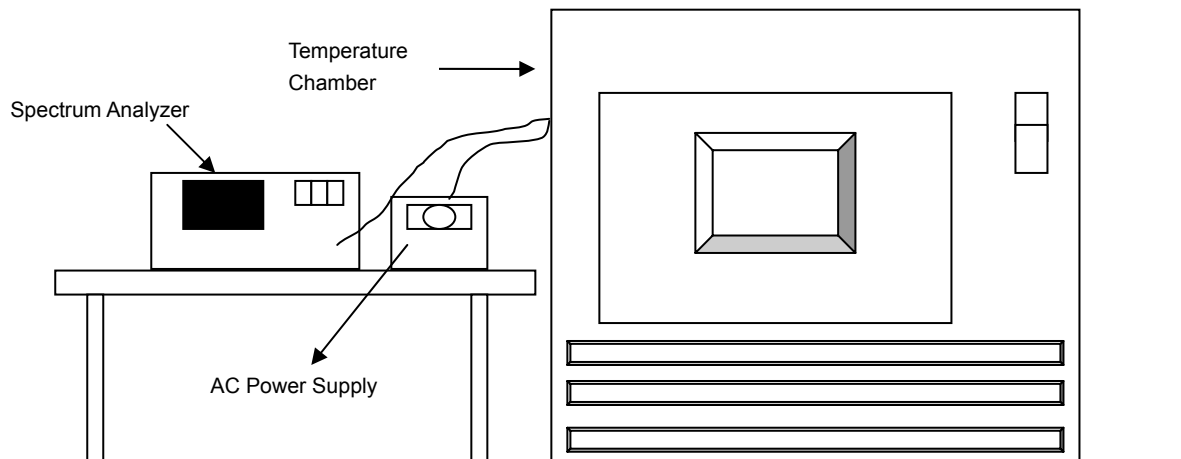

4.5.3 Test Instruments

Refer to section 4.1.2 to get information of above instrument.

4.5.4 Test Procedure

- The EUT was placed inside the environmental test chamber and powered by nominal AC voltage.
- Turn the EUT on and couple its output to a spectrum analyzer.
- Turn the EUT off and set the chamber to the highest temperature specified.
- Allow sufficient time (approximately 30 min) for the temperature of the chamber to stabilize, turn the EUT on and measure the operating frequency after 2, 5, and 10 minutes.
- Repeat step 2 and 3 with the temperature chamber set to the lowest temperature.
- The test chamber was allowed to stabilize at +20 degree C for a minimum of 30 minutes. The supply voltage was then adjusted on the EUT from 85% to 115% and the frequency record.

4.5.5 Deviation from Test Standard

No deviation.

4.5.6 EUT Operating Condition

Set the EUT transmit at un-modulation mode to test frequency stability.

4.5.7 Test Results

FREQUENCY STABILITY VERSUS TEMP.									
OPERATING FREQUENCY: 5180MHz									
TEMP. (°C)	POWER SUPPLY (Vac)	0 MINUTE		2 MINUTE		5 MINUTE		10 MINUTE	
		Measured Frequency (MHz)	Frequency Drift (%)	Measured Frequency (MHz)	Frequency Drift (%)	Measured Frequency (MHz)	Frequency Drift (%)	Measured Frequency (MHz)	Frequency Drift (%)
50	120	5180.0008	0.00002	5179.9985	-0.00003	5179.9981	-0.00004	5179.9988	-0.00002
40	120	5179.9816	-0.00036	5179.9842	-0.00031	5179.9819	-0.00035	5179.9826	-0.00034
30	120	5180.0079	0.00015	5180.0079	0.00015	5180.0079	0.00015	5180.0085	0.00016
20	120	5180.0062	0.00012	5180.0063	0.00012	5180.007	0.00014	5180.004	0.00008
10	120	5179.9864	-0.00026	5179.9887	-0.00022	5179.9878	-0.00024	5179.9865	-0.00026
0	120	5179.9782	-0.00042	5179.9785	-0.00042	5179.9799	-0.00039	5179.9787	-0.00041
-10	120	5180.0179	0.00035	5180.0176	0.00034	5180.0158	0.00031	5180.0153	0.00030
-20	120	5180.0043	0.00008	5180.0043	0.00008	5180.0038	0.00007	5180.0044	0.00008
-30	120	5179.9842	-0.00031	5179.985	-0.00029	5179.9832	-0.00032	5179.985	-0.00029

FREQUENCY STABILITY VERSUS VOLTAGE									
OPERATING FREQUENCY: 5180MHz									
TEMP. (°C)	POWER SUPPLY (Vac)	0 MINUTE		2 MINUTE		5 MINUTE		10 MINUTE	
		Measured Frequency (MHz)	Frequency Drift (%)	Measured Frequency (MHz)	Frequency Drift (%)	Measured Frequency (MHz)	Frequency Drift (%)	Measured Frequency (MHz)	Frequency Drift (%)
20	138	5180.0058	0.00011	5180.0068	0.00013	5180.0074	0.00014	5180.0037	0.00007
	120	5180.0062	0.00012	5180.0063	0.00012	5180.007	0.00014	5180.004	0.00008
	102	5180.0068	0.00013	5180.0058	0.00011	5180.0073	0.00014	5180.0034	0.00007

4.6 6dB Bandwidth Measurement

4.6.1 Limits of 6dB Bandwidth Measurement

The minimum of 6dB Bandwidth Measurement is 0.5MHz.

4.6.2 Test Setup

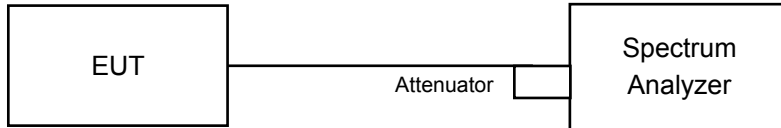

4.6.3 Test Instruments

Refer to section 4.1.2 to get information of above instrument.

4.6.4 Test Procedure

MEASUREMENT PROCEDURE REF

- a. Set resolution bandwidth (RBW) = 100kHz
- b. Set the video bandwidth (VBW) ≥ 3 x RBW, Detector = Peak.
- c. Trace mode = max hold.
- d. Sweep = auto couple.
- e. Measure the maximum width of the emission that is constrained by the frequencies associated with the two amplitude points (upper and lower) that are attenuated by 6 dB relative to the maximum level measured in the fundamental emission

4.6.5 Deviation from Test Standard

No deviation.

4.6.6 EUT Operating Condition

The software provided by client to enable the EUT under transmission condition continuously at lowest, middle and highest channel frequencies individually.

4.6.7 Test Results

CDD Mode

802.11a

Channel	Frequency (MHz)	6dB Bandwidth (MHz)			Minimum Limit (MHz)	Pass / Fail
		Chain 0	Chain 1	Chain 2		
149	5745	16.45	16.44	16.49	0.5	Pass
157	5785	16.45	16.45	16.48	0.5	Pass
165	5825	16.47	16.46	16.49	0.5	Pass

802.11ac (VHT20)

Channel	Frequency (MHz)	6dB Bandwidth (MHz)			Minimum Limit (MHz)	Pass / Fail
		Chain 0	Chain 1	Chain 2		
149	5745	17.73	17.72	17.70	0.5	Pass
157	5785	17.71	17.69	17.68	0.5	Pass
165	5825	17.71	17.68	17.68	0.5	Pass

802.11ac (VHT40)

Channel	Frequency (MHz)	6dB Bandwidth (MHz)			Minimum Limit (MHz)	Pass / Fail
		Chain 0	Chain 1	Chain 2		
151	5755	36.49	36.51	36.48	0.5	Pass
159	5795	36.47	36.50	36.46	0.5	Pass

802.11ac (VHT80)

Channel	Frequency (MHz)	6dB Bandwidth (MHz)			Minimum Limit (MHz)	Pass / Fail
		Chain 0	Chain 1	Chain 2		
155	5775	76.47	76.51	76.11	0.5	Pass

Spectrum Plot of Worst Value

802.11a – Chain 1: CH 149

802.11ac (VHT20) – Chain 2: CH 157

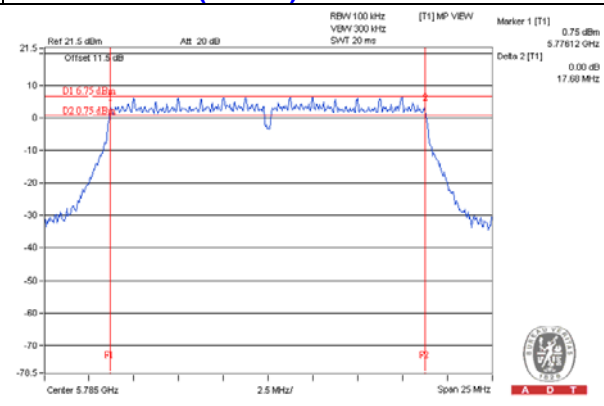
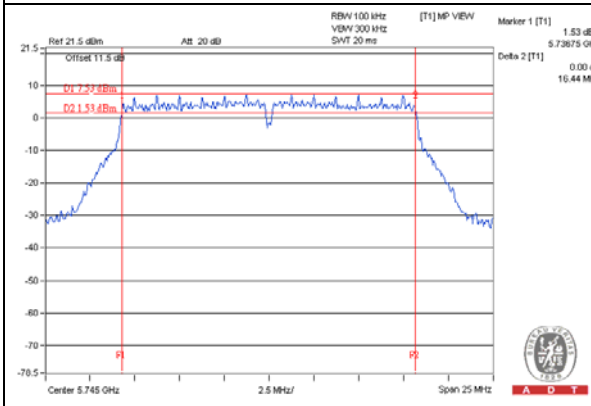

802.11ac (VHT40) – Chain 2: CH 159

802.11ac (VHT80) – Chain 2: CH 155

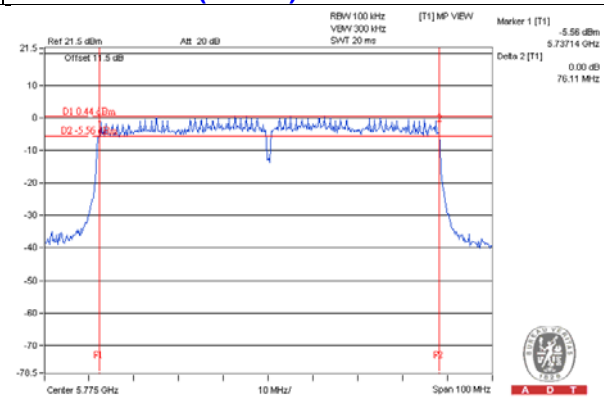
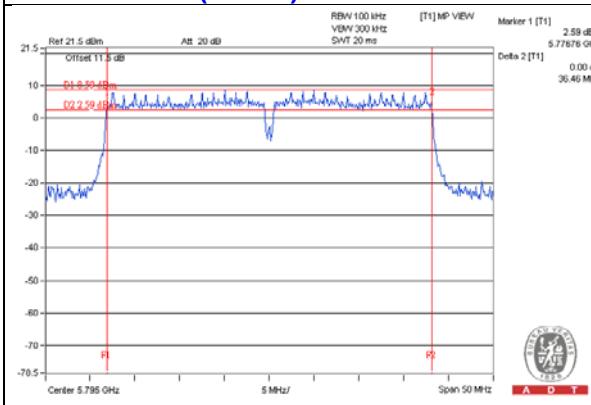

5 Pictures of Test Arrangements

Please refer to the attached file (Test Setup Photo).



Appendix – Information on the Testing Laboratories

We, Bureau Veritas Consumer Products Services (H.K.) Ltd., Taoyuan Branch, were founded in 1988 to provide our best service in EMC, Radio, Telecom and Safety consultation. Our laboratories are accredited and approved according to ISO/IEC 17025.

If you have any comments, please feel free to contact us at the following:

Linko EMC/RF Lab

Tel: 886-2-26052180

Fax: 886-2-26051924

Hsin Chu EMC/RF Lab/Telecom Lab

Tel: 886-3-5935343

Fax: 886-3-5935342

Hwa Ya EMC/RF/Safety

Tel: 886-3-3183232

Fax: 886-3-3270892

Email: service.adt@tw.bureauveritas.com

Web Site: www.bureauveritas-adt.com

The address and road map of all our labs can be found in our web site also.

--- END ---