

## FCC 47 CFR PART 15 SUBPART C

Product Type : HITI DUPLEX PHOTO PRINTER

Applicant : HiTi Digital, Inc.

Address : 9F., No. 225, Sec. 3, Beixin Rd., Xindian Dist., New Taipei City 231, Taiwan (R.O.C.)

Trade Name : hiti

Model Number : P530D,  
P53XXX (X:A~Z;a~z;0-9 or blank for marketing purpose)

Test Specification : FCC 47 CFR PART 15 SUBPART C  
ANSI C63.10:2013

Receive Date : Sep. 22, 2015

Test Period : Sep 25 ~ Dec. 02, 2015

Issue Date : Feb. 24, 2016

### Issue by

A Test Lab Techno Corp.  
No. 140-1, Changan Street, Bade District,  
Taoyuan City 33465, Taiwan (R.O.C)  
Tel : +886-3-2710188 / Fax : +886-3-2710190



Taiwan Accreditation Foundation accreditation number: 1330

**Note:** This report shall not be reproduced except in full, without the written approval of A Test Lab Techno Corp. This document may be altered or revised by A Test Lab Techno Corp. personnel only, and shall be noted in the revision section of the document. The client should not use it to claim product endorsement by TAF, or any government agencies. The test results in the report only apply to the tested sample.

**Revision History**

Rev.	Issue Date	Revisions	Revised By
00	Nov. 24, 2015	Initial Issue	
01	Nov. 27, 2015	Revised report information.	Snow Wang
02	Dec. 03, 2015	Revised report information.	Snow Wang
03	Feb. 24, 2016	Revised report information.	Joyce Liao

## Verification of Compliance

Issued Date: 2016/02/24

Product Type : HITI DUPLEX PHOTO PRINTER  
Applicant : HiTi Digital, Inc.  
Address : 9F., No.225, Sec.3, Beixin Rd., Xindian Dist., New Taipei City  
231, Taiwan(R.O.C.)  
Trade Name : hiti  
Model Number : P530D,  
P53XXX (X:A~Z;a~z;0-9 or blank for marketing purpose)  
FCC ID : W5388D2435000T  
EUT Rated Voltage : AC 100V ~ 240V, 50-60Hz, 5A  
Test Voltage : 120 Vac / 60 Hz  
Applicable Standard : FCC 47 CFR PART 15 SUBPART C  
ANSI C63.10:2013

Test Result : Complied

Performing Lab. : A Test Lab Techno Corp.

No. 140-1, Changan Street, Bade District,  
Taoyuan City 33465, Taiwan (R.O.C)

Tel : +886-3-2710188 / Fax : +886-3-2710190

Taiwan Accreditation Foundation accreditation number: 1330

<http://www.atl-lab.com.tw/e-index.htm>



A Test Lab Techno Corp. tested the above equipment in accordance with the requirements set forth in the above standards. All indications of Pass/Fail in this report are opinions expressed by A Test Lab Techno Corp. based on interpretations and/or observations of test results. Measurement Uncertainties were not taken into account and are published for informational purposes only. The test results show that the equipment tested is capable of demonstrating compliance with the requirements as documented in this report.

Approved By : Fly Lu Reviewed By : Eric Ou Yang  
(Manager) (Fly Lu) (Testing Engineer) (Eric Ou Yang)

**TABLE OF CONTENTS**

1	General Information .....	5
2	EUT Description.....	6
3	Test Methodology .....	7
3.1.	Mode of Operation .....	7
3.2.	EUT Exercise Software.....	7
3.3.	Configuration of Test System Details .....	7
3.4.	Test Site Environment.....	8
4	Conducted Emission Measurement .....	9
4.1.	Limit .....	9
4.2.	Test Instruments .....	9
4.3.	Test Setup.....	9
4.4.	Test Procedure.....	10
4.5.	Test Result .....	11
5	Radiated Emissions Measurement .....	13
5.1.	Limit .....	13
5.2.	Test Instruments .....	14
5.3.	Setup .....	15
5.4.	Test Procedure.....	16
5.5.	Test Result .....	18
6	Frequency Stability Measurement .....	28
6.1.	Limit .....	28
6.2.	Test Setup.....	28
6.3.	Test Instruments .....	28
6.4.	Test Procedure.....	29
6.5.	Test Result .....	29
7	20dB Bandwidth Measurement.....	30
7.1.	Limit .....	30
7.2.	Test Setup.....	30
7.3.	Test Instruments .....	30
7.4.	Test Procedure.....	31
7.5.	Test Result .....	32
7.6.	Test Graphs .....	32
8	Antenna Requirement.....	33
8.1.	Require .....	33
8.2.	Antenna Connector Construction.....	33

## 1 General Information

### 1.1 Summary of Test Result

Reference	Test	Results	Remark
<b>47 CFR Part 15.225</b>			
15.203	Antenna Requirement	Meet Require	---
15.207(a)	Conducted Emissions Voltage	PASS	---
15.225 (a), (b), (c), (d) 15.209	Radiated Emission Limits	PASS	---
15.225(e)	Frequency Stability	PASS	---
15.215(c)	20dB Bandwidth	-----	---

CFR 47 Part 15.225 / ANSI C63.10:2013

The test results of this report relate only to the tested sample(s) identified in this report. Manufacturer or whom it may concern should recognize the pass or fail of the test result.

### 1.2 Measurement Uncertainty

Test Item	Frequency Range	Uncertainty (dB)
Conducted Emission	9kHz ~ 150KHz	2.7
	150kHz ~ 30MHz	2.8
Radiated Emission	9kHz ~ 30MHz	1.457
	30MHz ~ 1000MHz	6.300
	1000MHz ~ 18000MHz	5.474
	18000MHz ~ 26500MHz	5.630
	26500MHz ~ 40000MHz	5.054

## 2 EUT Description

Applicant	HiTi Digital, Inc.
Applicant Address	9F., No. 225, Sec. 3, Beixin Rd., Xindian Dist., New Taipei City 231, Taiwan (R.O.C.)
Manufacturer	HiTi Digital, Inc.
Manufacturer Address	9F., No. 225, Sec. 3, Beixin Rd., Xindian Dist., New Taipei City 231, Taiwan (R.O.C.)
Product	HITI DUPLEX PHOTO PRINTER
Trade Name	hiti
Model Number	P530D, P53XXX (X:A~Z;a~z;0-9 or blank for marketing purpose)
FCC ID	W5388D2435000T
Model Different Description	These model number differ from each other in selling region.
Frequency Range	13.56 MHz
Modulation Type	ASK
Number of Channels	1 Channel
Antenna Type	Loop Antenna

### 3 Test Methodology

#### 3.1. Mode of Operation

The following test mode(s) were scanned during the preliminary test :

<b>Pre-Test Mode</b>
Mode 1: Normal Operation Mode
Mode 2: Transmit Mode
Mode 3: Receive Mode

ATL has verified the construction and function in typical operation. All the test modes were carried out with the EUT in normal operation.

#### 3.2. EUT Exercise Software

1.	Setup the EUT as shown on 3.3.
2.	Turn on the power of all equipment.
3.	The EUT will start to operate function.

#### 3.3. Configuration of Test System Details

Conducted Emission

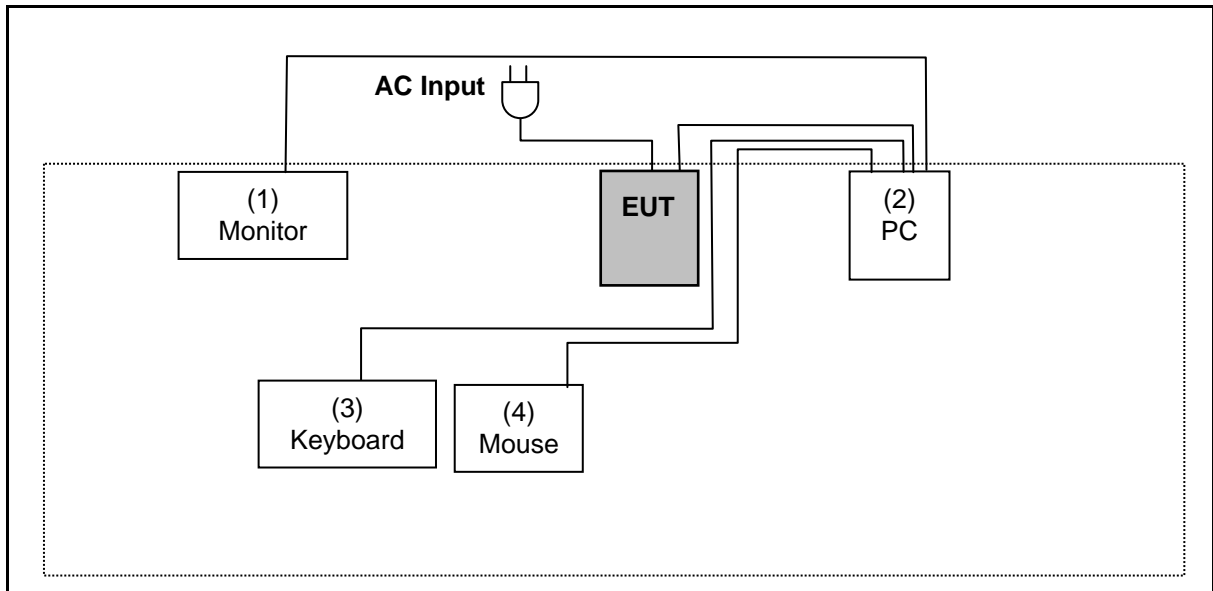

Radiated Emission

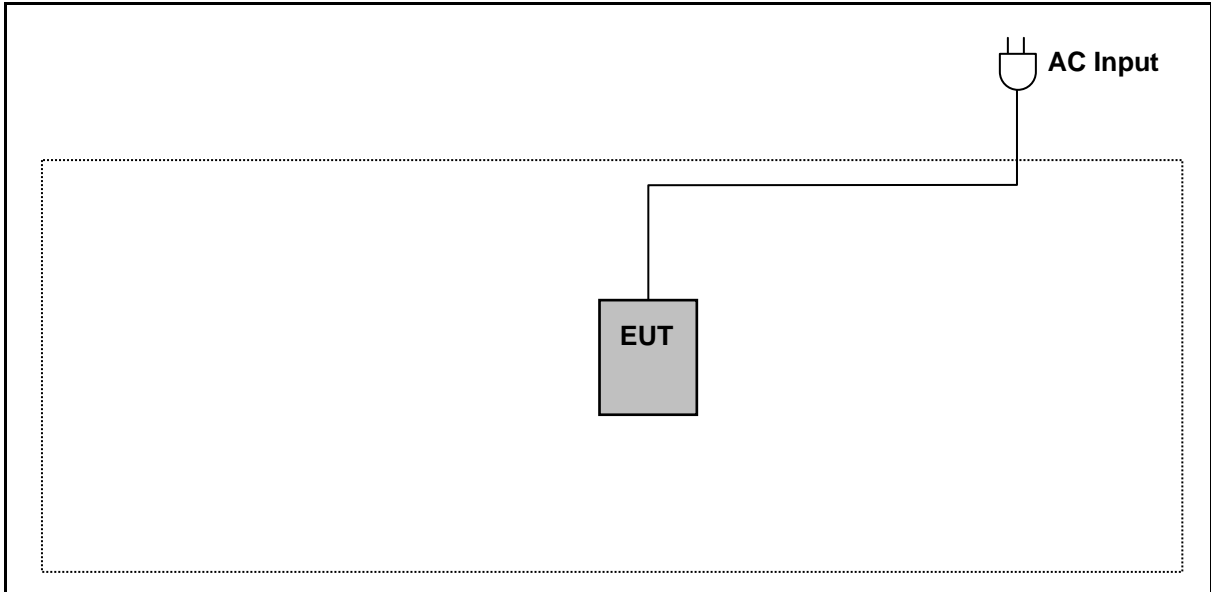

Devices Description						
	Product	Manufacturer	Model Number	FCC ID	Serial Number	Power Cord
(1)	Monitor	DELL	P2415Qb	DoC	CN-0D3C8X-74261-523-OHUL	Non-Shielded, 1.8m
(2)	PC	DELL	Inspriion 560 MT	DoC	C9TDF-JRKBV-P2B7D-XBJ3B-2RQ93XT6-96072	Non-Shielded, 1.8m
(3)	Keyboard	DELL	SK-8115	DoC	MY0DJ3257161971B1197	Power by PC
(4)	Mouse	DELL	MOC5UO	DoC	I0S02009	Power by PC

**3.4. Test Site Environment**

Items	Required (IEC 60068-1)	Actual
Temperature (°C)	15-35	26
Humidity (%RH)	25-75	60
Barometric pressure (mbar)	860-1060	950



## 4 Conducted Emission Measurement

### 4.1. Limit

Frequency (MHz)	Quasi-peak	Average
0.15 - 0.5	66 to 56	56 to 46
0.50 - 5.0	56	46
5.0 - 30.0	60	50

### 4.2. Test Instruments

Describe	Manufacturer	Model Number	Serial Number	Cal. Date	Remark
Test Receiver	R&S	ESCI	100367	06/25/2015	(1)
LISN	R&S	ENV216	101040	03/10/2015	(1)
LISN	R&S	ENV216	101041	03/06/2015	(1)
Microwave Cable	EMCI	EMC104-SM-SM-1500	140303	02/24/2015	(1)
Test Site	ATL	TE02	TE02	N.C.R.	-----

Remark: <sup>(1)</sup> Calibration period 1 year. <sup>(2)</sup> Calibration period 2 years.

NOTE: N.C.R. = No Calibration Request.

### 4.3. Test Setup

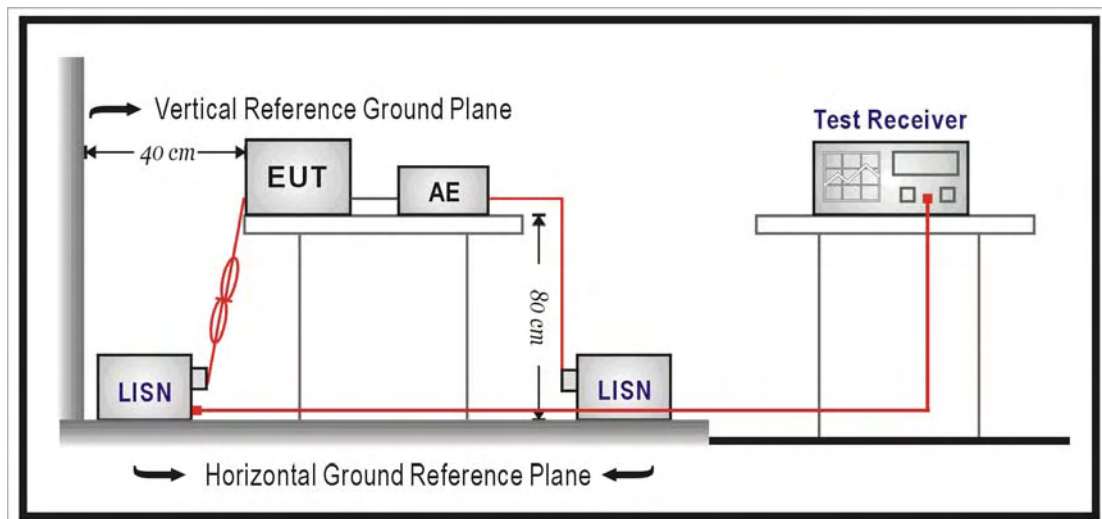

#### 4.4. Test Procedure

The EUT and simulators are connected to the main power through a line impedance stabilization network (L.I.S.N.). This provides a 50 ohm /50uH coupling impedance for the measuring equipment. The peripheral devices are also connected to the main power through a LISN that provides a 50ohm/50uH coupling impedance with 50ohm termination. For A.C. mains conducted interference, measured both sides of A.C. lines and carried out using quasi-peak and average detector receivers of maximum conducted interference. Conducted emissions were investigated over the frequency range from 0.15 MHz to 30 MHz using a receiver bandwidth of 9 kHz. The equipment under test (EUT) shall be meet the limits in section 4.1.1, as applicable, including the average limit and the quasi-peak limit when using respectively, an average detector and quasi-peak detector measured in accordance with the methods described of related standard. The voltage limits shall be met. If the average limit is met when using a quasi-peak detector receiver, the EUT shall be deemed to meet both limits and measurement with the average detector receiver is unnecessary. If the reading of the measuring receiver shows fluctuations close to the limit, the reading shall be observed for at least 15 s at each measurement frequency; the higher reading shall be recorded with the exception of any brief isolated high reading which shall be ignored.

#### 4.5. Test Result

Standard:	FCC Part 15C	Line:	L1
Test item:	Conducted Emission	Power:	AC 120V/60Hz
Model Number:	P530D	Temp.(°C)/Hum.(%RH):	26(°C)/60%RH
Mode:	Mode 1	Date:	12/02/2015
		Test By:	Eric Ou Yang
Description:		Power Board Model: N270A001L	

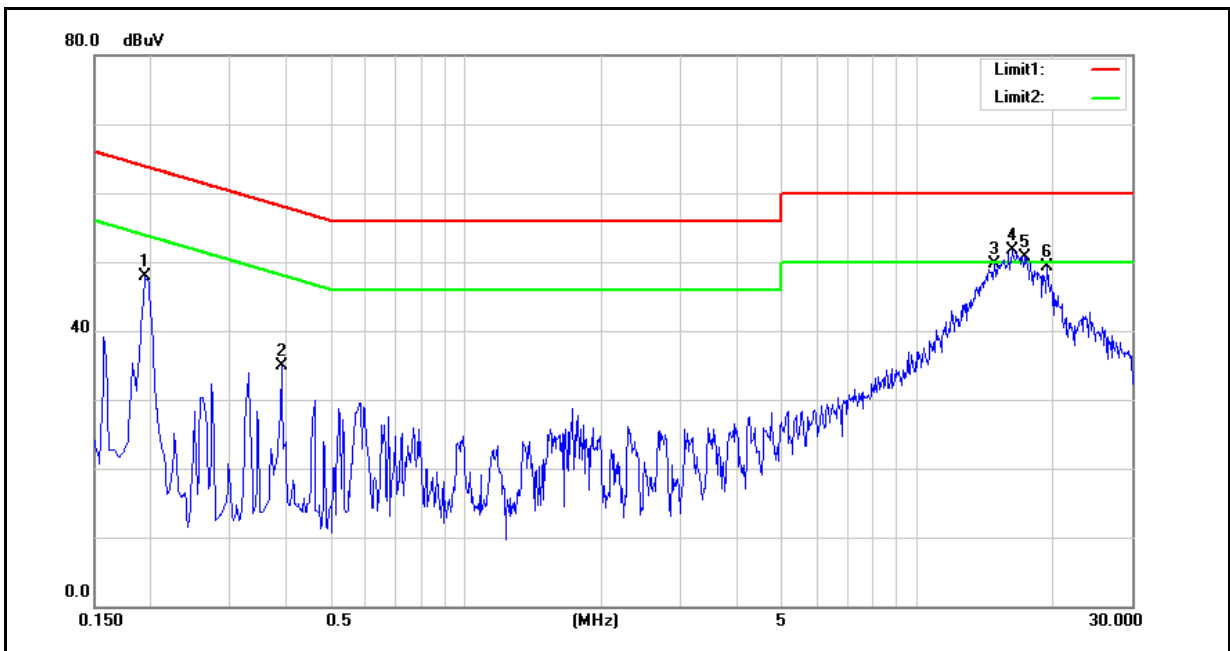

No.	Frequency (MHz)	QP reading (dBuV)	AVG reading (dBuV)	Correction factor (dB)	QP result (dBuV)	AVG result (dBuV)	QP limit (dBuV)	AVG limit (dBuV)	QP margin (dB)	AVG margin (dB)	Remark
1	0.1940	35.39	31.82	9.68	45.07	41.50	63.86	53.86	-18.79	-12.36	Pass
2	0.3900	22.01	13.18	9.69	31.70	22.87	58.06	48.06	-26.36	-25.19	Pass
3	14.8740	35.93	21.60	10.02	45.95	31.62	60.00	50.00	-14.05	-18.38	Pass
4	16.3620	38.37	23.61	10.02	48.39	33.63	60.00	50.00	-11.61	-16.37	Pass
5	17.4140	36.45	21.63	10.03	46.48	31.66	60.00	50.00	-13.52	-18.34	Pass
6	19.4820	33.47	17.36	10.05	43.52	27.41	60.00	50.00	-16.48	-22.59	Pass

Note: 1. Result (dBuV) = Correction factor (dB) + Reading(dBuV).

2. Correction factor (dB) = Cable loss (dB) + L.I.S.N. factor (dB).

Standard:	FCC Part 15C	Line:	N
Test item:	Conducted Emission	Power:	AC 120V/60Hz
Model Number:	P530D	Temp.(°C)/Hum.(%RH):	26(°C)/60%RH
Mode:	Mode 1	Date:	12/02/2015
		Test By:	Eric Ou Yang
Description:		Power Board Model: N270A001L	

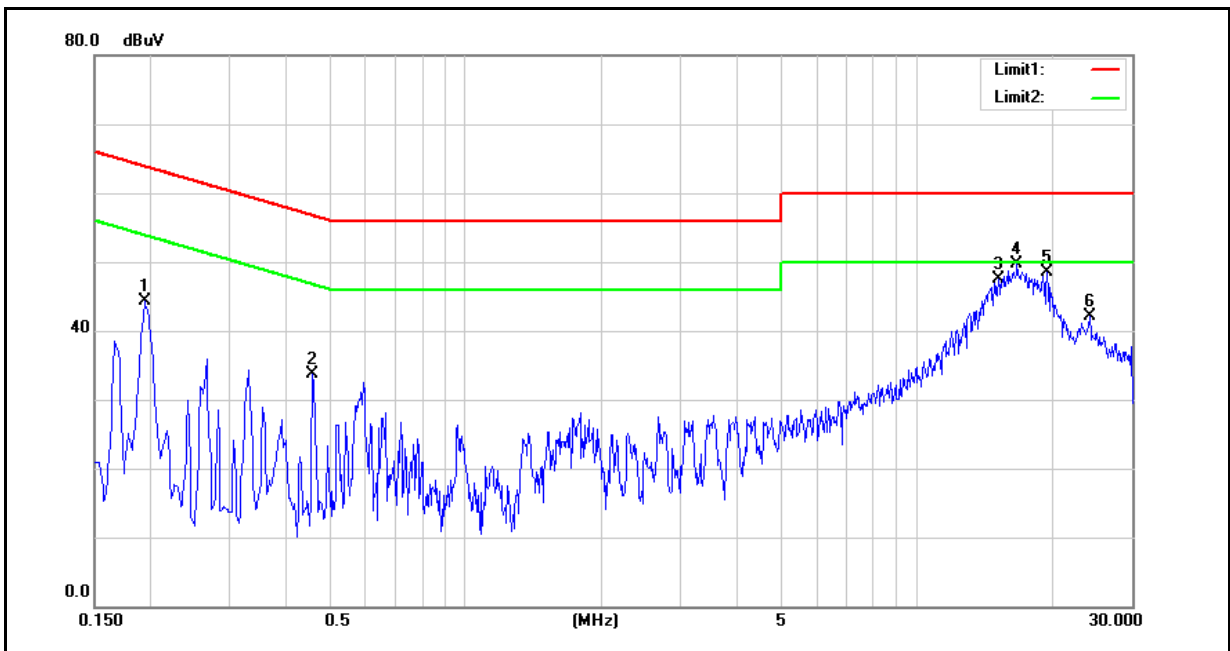

No.	Frequency (MHz)	QP reading (dBuV)	AVG reading (dBuV)	Correction factor (dB)	QP result (dBuV)	AVG result (dBuV)	QP limit (dBuV)	AVG limit (dBuV)	QP margin (dB)	AVG margin (dB)	Remark
1	0.1940	35.58	31.90	9.65	45.23	41.55	63.86	53.86	-18.63	-12.31	Pass
2	0.4580	21.92	14.79	9.67	31.59	24.46	56.73	46.73	-25.14	-22.27	Pass
3	15.1740	33.51	19.57	10.07	43.58	29.64	60.00	50.00	-16.42	-20.36	Pass
4	16.7460	35.42	21.02	10.10	45.52	31.12	60.00	50.00	-14.48	-18.88	Pass
5	19.4580	33.86	19.79	10.15	44.01	29.94	60.00	50.00	-15.99	-20.06	Pass
6	24.1980	27.18	13.39	10.19	37.37	23.58	60.00	50.00	-22.63	-26.42	Pass

Note: 1. Result (dBuV) = Correction factor (dB) + Reading(dBuV).

2. Correction factor (dB) = Cable loss (dB) + L.I.S.N. factor (dB).

## 5 Radiated Emissions Measurement

### 5.1. Limit

According to §15.225,

- (a) The field strength of any emissions within the band 13.553 – 13.567 MHz shall not exceed 15,848 microvolt / meter at 30 meters.
- (b) Within the bands 13.410 – 13.553 MHz and 13.567 -13.710 MHz, the field strength of any emissions shall not exceed 334 microvolt / meter at 30 meters.
- (c) Within the bands 13.110 – 13.410 MHz and 13.710 – 14.010 MHz the field strength of any emissions shall not exceed 106 microvolt / meter at 30 meters.
- (d) The field strength of any emissions appearing outside of the 13.110 – 14.010 MHz and shall not exceed the general radiated emission limits in §15.209.

According to §15.225(a), except as provided elsewhere in this Subpart, the emissions from an intentional radiator shall not exceed the field strength levels specified in the following table:

Frequency (MHz)	Field Strength ( $\mu$ V/m at meter)	Measurement Distance (meter)
0.009 – 0.490	2400 / F (kHz)	300
0.490 – 1.705	24000 / F (kHz)	30
1.705 – 30.0	30	30
30 - 88	100**	3
88-216	150**	3
216-960	200**	3
Above 960	500	3

\*\* Except as provided in paragraph (g), fundamental emissions from intentional radiators operating under this Section shall not be located in the frequency bands 54-72 MHz, 76-88 MHz, 174-216 MHz or 470-806 MHz. However, operation within these frequency bands is permitted under other sections of this Part, e.g., Sections 15.231 and 15.241.

## 5.2. Test Instruments

3 Meter Chamber					
Equipment	Manufacturer	Model Number	Serial Number	Cal. Date	Remark
RF Pre-selector	Agilent	N9039A	MY46520256	01/06/2015	(1)
Spectrum Analyzer	Agilent	E4446A	MY46180578	01/06/2015	(1)
Pre Amplifier	Agilent	8449B	3008A02237	02/24/2015	(1)
Pre Amplifier	Agilent	8447D	2944A10961	02/24/2015	(1)
Broadband Antenna (30MHz~1GHz)	SCHWARZBECK MESS-ELEKTRONIK	VULB9163	9163-270	08/11/2015	(1)
Horn Antenna (1~18GHz)	SCHWARZBECK MESS-ELEKTRONIK	BBHA9120D	9120D-550	06/12/2015	(1)
Horn Antenna (18~40GHz)	SCHWARZBECK MESS-ELEKTRONIK	BBHA9170	9170-320	07/06/2015	(1)
Loop Antenna	COM-POWER CORPORATION	AL-130	121014	02/02/2015	(1)
Microwave Cable	EMCI	EMC-104-SM-SM-14000	140202	02/24/2015	(1)
Microwave Cable	EMCI	EMC104-SM-SM-600	140301	02/24/2015	(1)
Test Site	ATL	TE01	888001	08/27/2015	(1)

Remark: <sup>(1)</sup> Calibration period 1 year.

NOTE: N.C.R. = No Calibration Request.

### 5.3. Setup

9kHz ~ 30MHz

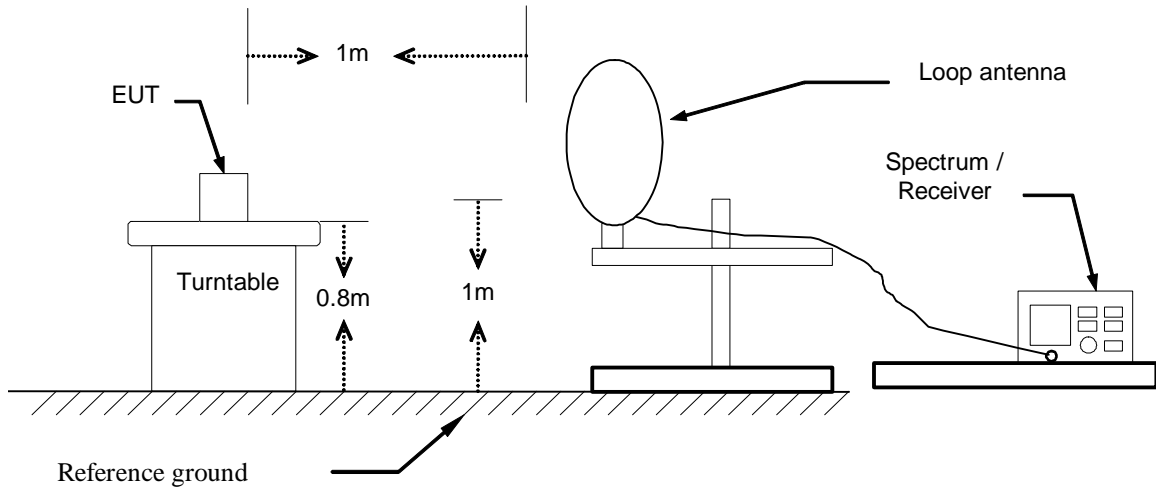

30MHz ~ 1 GHz

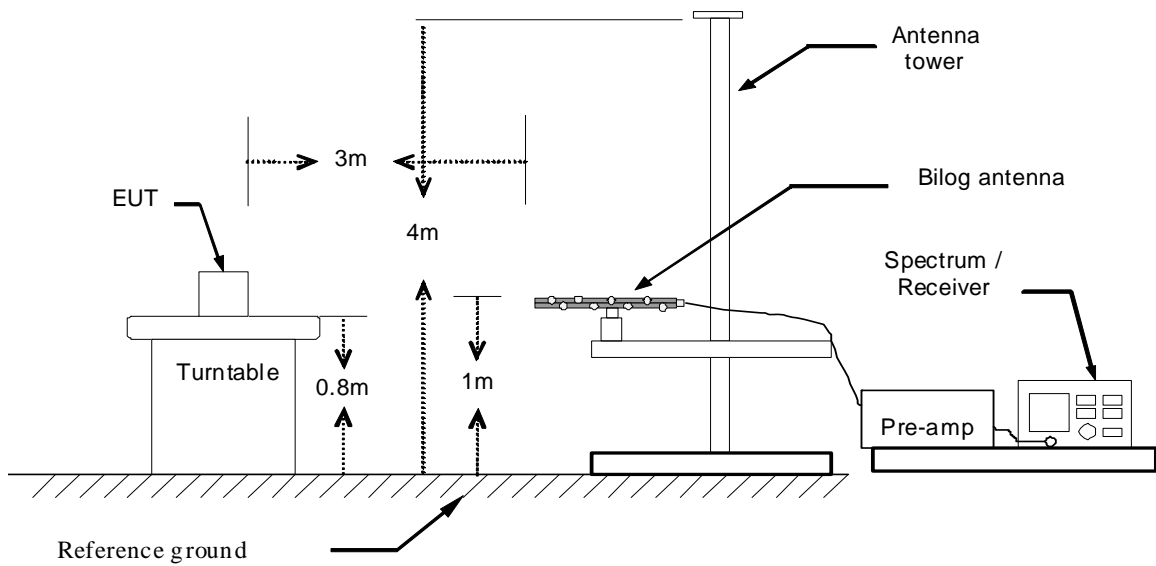

#### 5.4. Test Procedure

Final radiation measurements were made on a three-meter Semi Anechoic Chamber. The EUT system was placed on a nonconductive turntable which is 0.8 meters height, top surface 1.0 x 1.5 meter. The spectrum was examined from 3 Hz to 44 GHz in order to cover the whole spectrum below 10th harmonic which could generate from the EUT. During the test, EUT was set to transmit continuously.

For measurements below 1 GHz the resolution bandwidth is set to 100 kHz for peak detection measurements or 120 kHz for quasi-peak detection measurements. Peak detection is used unless otherwise noted as quasi-peak.

For measurements above 1 GHz the resolution bandwidth is set to 1 MHz, and then the video bandwidth is set to 1 MHz for peak measurements and 10 Hz for average measurements.

A nonconductive material surrounded the EUT to supporting the EUT for standing on three orthogonal planes. At each condition, the EUT was rotated 360 degrees, and the antenna was raised and lowered from one to four meters to find the maximum emission levels. Measurements were taken using both horizontal and vertical antenna polarization.

Broadband/Horn Antenna (model: VULB 9163/BBHA9120D) were used in frequency 30MHz to 18 GHz at a distance of 3 meter. Loop/Horn Antenna (model: AL-130/ BBHA 9170) was used in frequency 9kHz to 30MHz and 18 to 26.5 GHz at a distance of 1 meter. All test results were extrapolated to equivalent signal at 3 meters utilizing an inverse linear distance extrapolation Factor (20dB/decade).

For testing above 1GHz, the emission level of the EUT in peak mode was 20dB lower than average limit (that means the emission level in peak mode also complies with the limit in average mode), then testing will be stopped and peak values of EUT will be reported, otherwise, the emissions will be measured in average mode again and reported.

Appropriate preamplifiers were used for improving sensitivity and precautions were taken to avoid overloading or desensitizing the spectrum analyzer. No post – detector video filters were used in the test.

The spectrum analyzer's 6 dB bandwidth was set to 1 MHz, and the analyzer was operated in the peak detection mode, for frequencies both below and up 1 GHz. The average levels were obtained by subtracting the duty cycle correction factor from the peak readings.

The following procedures were used to convert the emission levels measured in decibels referenced to 1 microvolt (dBuV) into field intensity in microvolt pre-meter (uV/m).

The actual field intensity in decibels referenced to 1 microvolt in to field intensity in microvolt per-meter (dBuV/m).



The actual field intensity in referenced to 1 microvolt per meter (dBuV/m) is determined by algebraically adding the measured reading in dBuV, the antenna factor (dB), and cable loss (dB) and Subtracting the gain of preamplifier (dB) is auto calculate in spectrum analyzer.

(1)  $\text{Amplitude (dBuV/m)} = \text{FI (dBuV)} + \text{AF (dB)} + \text{CL (dB)} - \text{Gain (dB)}$

FI= Reading of the field intensity.

AF= Antenna factor.

CL= Cable loss.

P.S Amplitude is auto calculate in spectrum analyzer.

(2)  $\text{Actual Amplitude (dBuV/m)} = \text{Amplitude (dBuV)} - \text{Dis (dB)}$

The FCC specified emission limits were calculated according the EUT operating frequency and by following linear interpolation equations:

(a) For fundamental frequency : Transmitter Output < +30dBm

(b) For spurious frequency : Spurious emission limits = fundamental emission limit /10

Data of measurement within this frequency range without mark in the table above means the reading of emissions are attenuated more than 20dB below the permissible limits or the field strength is too small to be measured.

## 5.5. Test Result

### Fundamental Test Result:

Standard:	FCC Part 15C	Test Distance:	1m
Test item:	Radiated Emission	Power:	AC 120V/60Hz
Model Number:	P530D	Temp.(°C)/Hum.(%RH):	26(°C)/60%RH
Mode:	Mode 2	Date:	10/06/2015
Ant.Polar.:	Horizontal	Test By:	Eric Ou Yang

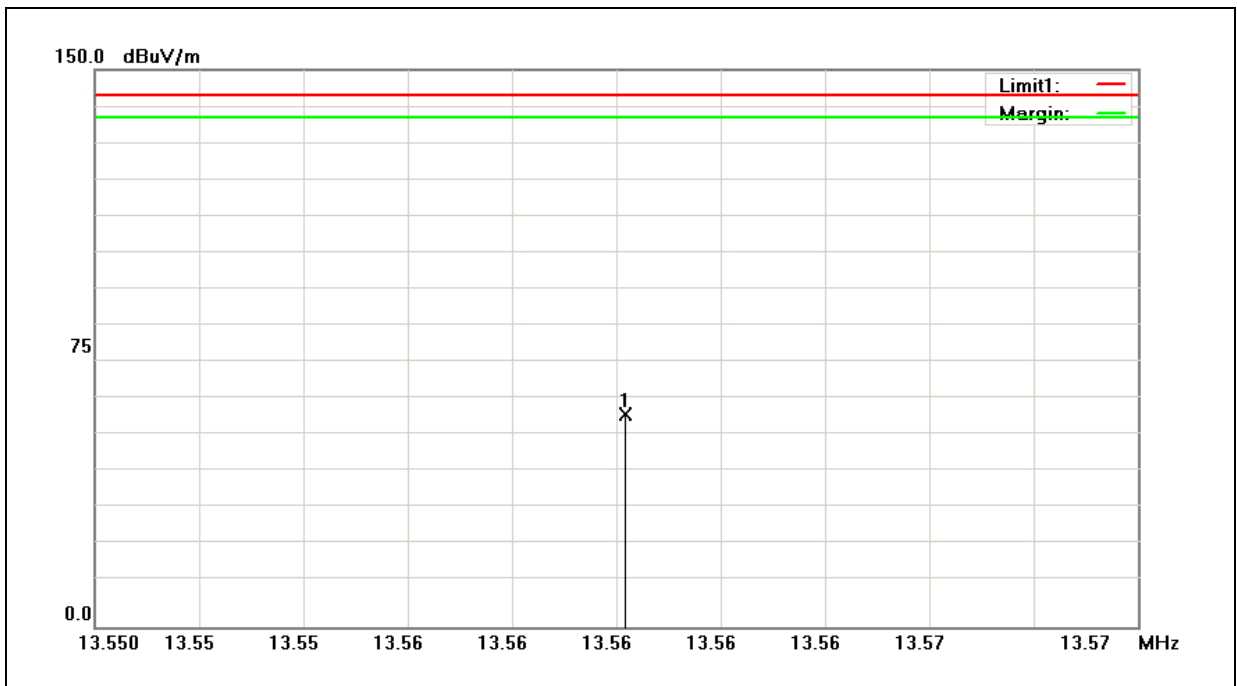

No.	Frequency (MHz)	Reading (dBuV)	Correct Factor (dB/m)	Near-Field Result (dBuV)	Derived Value (dBuV)	Limit (dBuV/m)	Margin (dB)	Remark
1	13.5602	43.02	14.18	57.20	16.73	84.00	-67.27	peak

Note: The level is measured at 1 meter and is converted into result at 30 meter.

The converted formula listed below:

Measure result (1 meter distance): a

Compute result (30 meter distance): A

$d_{\text{near field}} = \lambda/2\pi$ ,  $d_{\text{measure}} = 1$  meter distance

$A = a - 40 \cdot \log(d_{\text{near field}} / d_{\text{measure}}) - 20 \cdot \log(d_{\text{limit}} / d_{\text{near field}})$

ex.  $a = 57.20$  dBuV,  $A = 57.20 - 40 \cdot \log(3.52/1) - 20 \cdot \log(30/3.52)$  dBuV = 16.73 dBuV

Standard:	FCC Part 15C	Test Distance:	1m
Test item:	Radiated Emission	Power:	AC 120V/60Hz
Model Number:	P530D	Temp.(°C)/Hum.(%RH):	26(°C)/60%RH
Mode:	Mode 2	Date:	10/06/2015
Ant.Polar.:	Vertical	Test By:	Eric Ou Yang

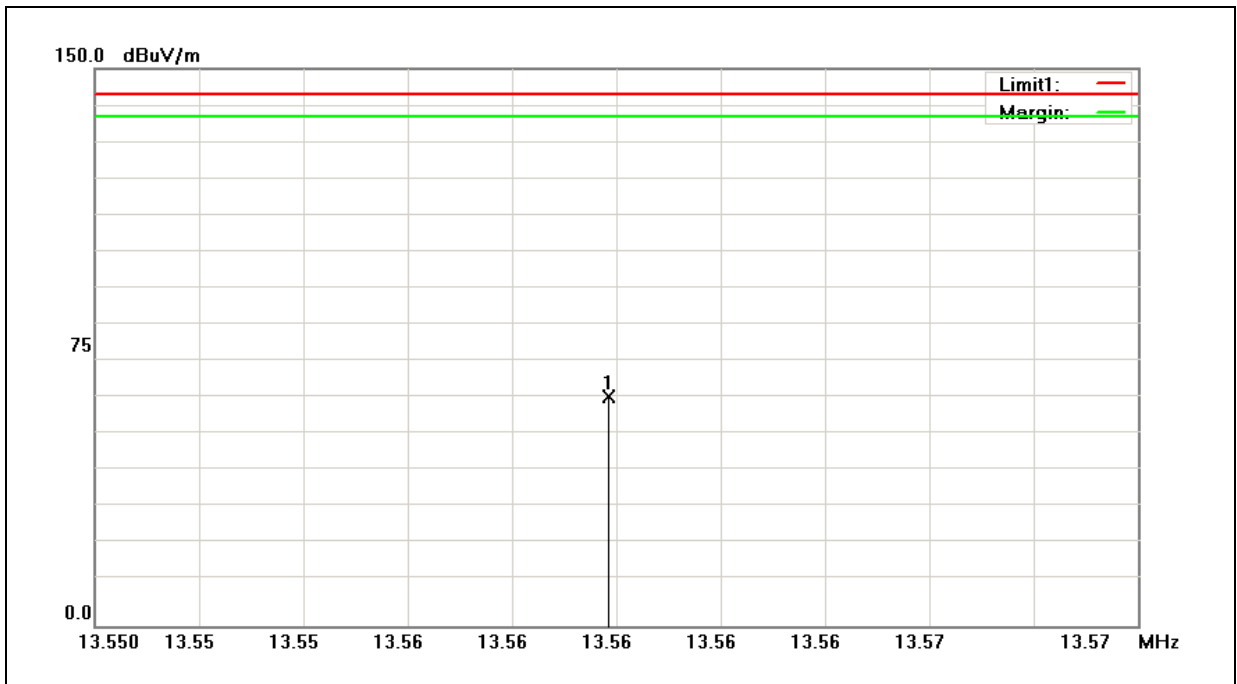

No.	Frequency (MHz)	Reading (dBuV)	Correct Factor (dB/m)	Near-Field Result (dBuV)	Derived Value (dBuV)	Limit (dBuV/m)	Margin (dB)	Remark
1	13.5600	47.33	14.18	61.51	21.04	84.00	-62.96	peak

Note: The level is measured at 1 meter and is converted into result at 30 meter.

**9kHz ~ 30MHz:**

Standard:	FCC Part 15C	Test Distance:	1m
Test item:	Radiated Emission	Power:	AC 120V/60Hz
Model Number:	P530D	Temp.(°C)/Hum.(%RH):	26(°C)/60%RH
Mode:	Mode 2	Date:	10/06/2015
Ant.Polar.:	Horizontal	Test By:	Eric Ou Yang

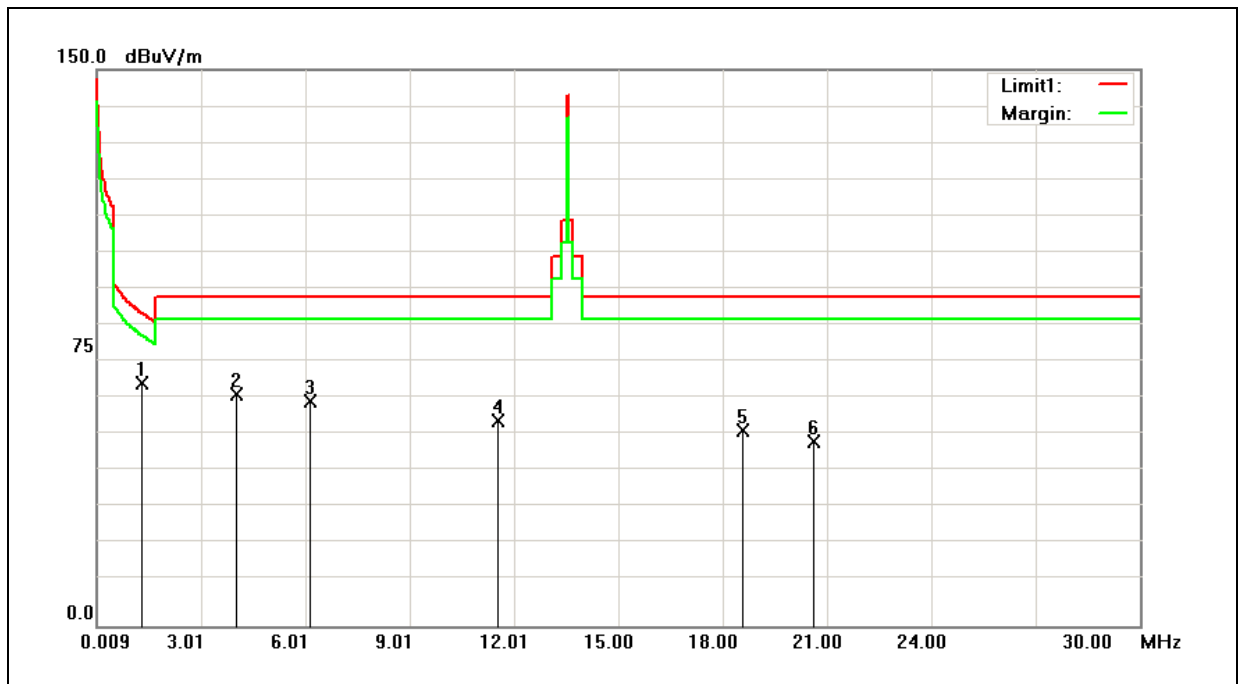

No.	Frequency (MHz)	Reading (dBuV)	Correct Factor (dB/m)	Near-Field Result (dBuV/m)	Derived Value (dBuV)	Limit (dBuV/m)	Margin (dB)	Remark
1	1.2983	50.52	14.95	65.47	4.62	25.34	-20.72	QP
2	4.0278	47.01	15.43	62.44	11.42	29.54	-18.12	QP
3	6.1570	44.76	15.79	60.55	13.21	29.54	-16.33	QP
4	11.5555	40.76	14.61	55.37	13.51	29.54	-16.03	QP
5	18.5731	38.32	14.21	52.53	14.79	29.54	-14.75	QP
6	20.6127	35.73	14.14	49.87	13.02	29.54	-16.52	QP

Note: The level is measured at 1 meter and is converted into result at 300 or 30 meter.

Standard:	FCC Part 15C	Test Distance:	1m
Test item:	Radiated Emission	Power:	AC 120V/60Hz
Model Number:	P530D	Temp.(°C)/Hum.(%RH):	26(°C)/60%RH
Mode:	Mode 2	Date:	10/06/2015
Ant.Polar.:	Vertical	Test By:	Eric Ou Yang

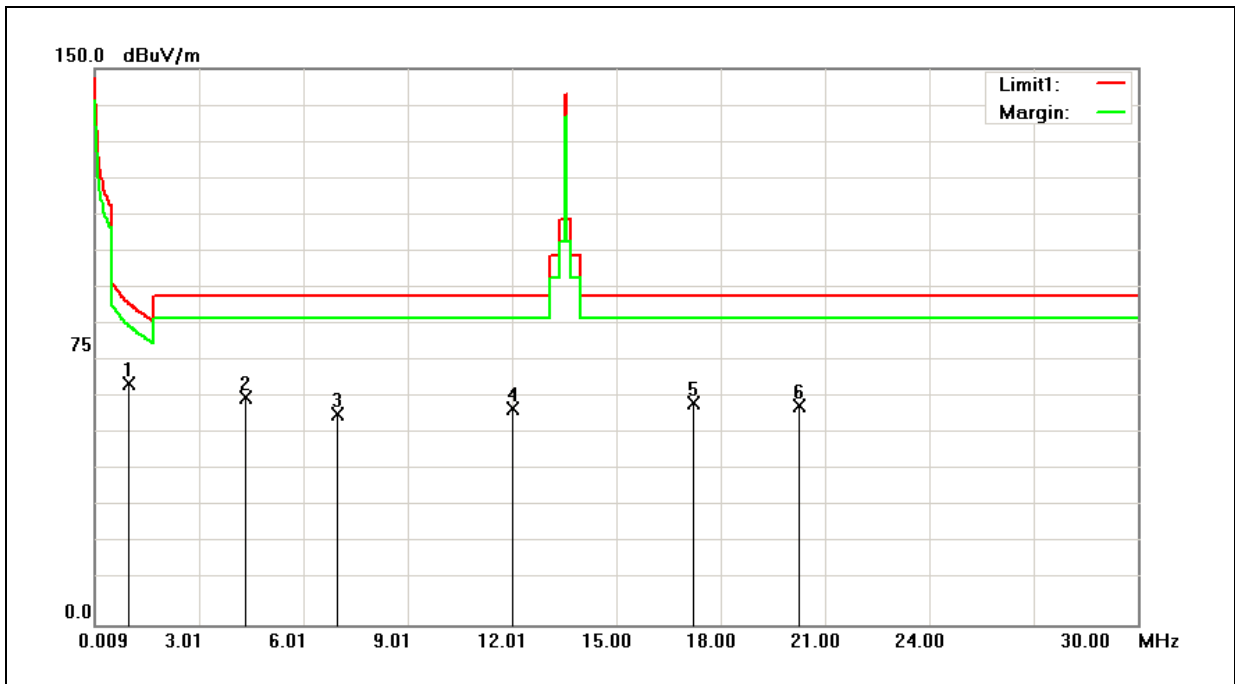

No.	Frequency (MHz)	Reading (dBuV)	Correct Factor (dB/m)	Near-Field Result (dBuV/m)	Derived Value (dBuV)	Limit (dBuV/m)	Margin (dB)	Remark
1	0.9987	50.07	14.92	64.99	1.86	27.62	-25.76	QP
2	4.3577	45.54	15.63	61.17	10.83	29.54	-18.71	QP
3	6.9970	41.16	15.61	56.77	10.55	29.54	-18.99	QP
4	12.0053	43.78	14.50	58.28	16.74	29.54	-12.80	QP
5	17.2238	45.78	14.08	59.86	21.47	29.54	-8.07	QP
6	20.2530	44.70	14.26	58.96	21.96	29.54	-7.58	QP

Note: The level is measured at 1 meter and is converted into result at 300 or 30 meter.

Standard:	FCC Part 15C	Test Distance:	300/30m
Test item:	Radiated Emission	Power:	AC 120V/60Hz
Model Number:	P530D	Temp.(°C)/Hum.(%RH):	26(°C)/60%RH
Mode:	Mode 3	Date:	10/06/2015
Ant.Polar.:	Horizontal	Test By:	Eric Ou Yang

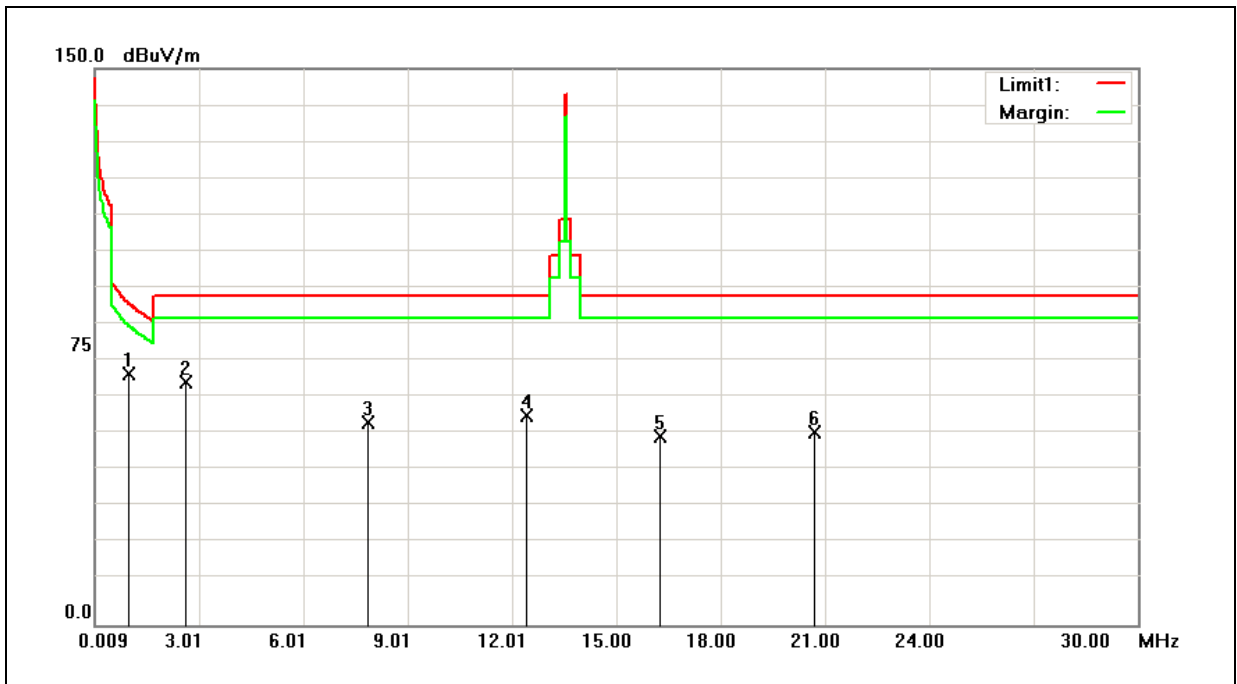

No.	Frequency (MHz)	Reading (dBuV)	Correct Factor (dB/m)	Near-Field Result (dBuV/m)	Derived Value (dBuV)	Limit (dBuV/m)	Margin (dB)	Remark
1	0.9987	52.83	14.92	67.75	4.62	27.62	-23.00	QP
2	2.6180	49.65	15.67	65.32	10.56	29.54	-18.99	QP
3	7.8666	39.31	15.43	54.74	9.53	29.54	-20.01	QP
4	12.4253	42.04	14.41	56.45	15.22	29.54	-14.32	QP
5	16.2640	36.77	13.98	50.75	11.84	29.54	-17.70	QP
6	20.7027	37.76	14.12	51.88	15.07	29.54	-14.48	QP

Note: The level is measured at 1 meter and is converted into result at 300 or 30 meter.

Standard:	FCC Part 15C	Test Distance:	300/30m
Test item:	Radiated Emission	Power:	AC 120V/60Hz
Model Number:	P530D	Temp.(°C)/Hum.(%RH):	26(°C)/60%RH
Mode:	Mode 3	Date:	10/06/2015
Ant.Polar.:	Vertical	Test By:	Eric Ou Yang

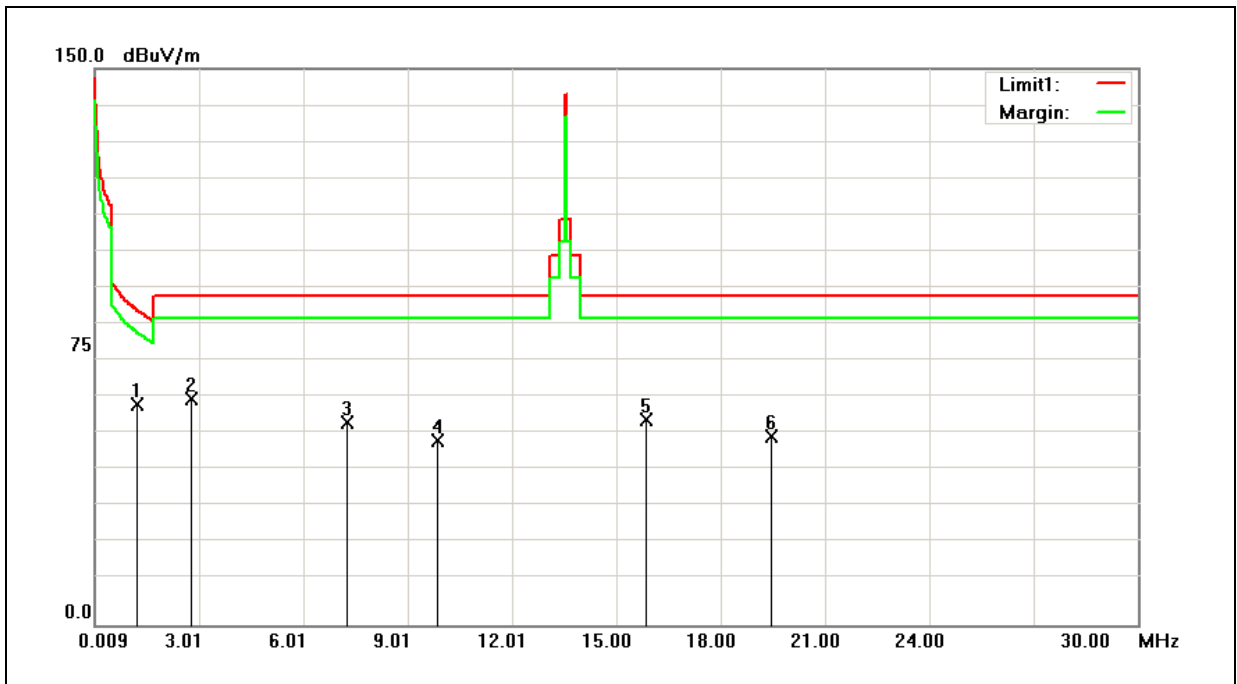

No.	Frequency (MHz)	Reading (dBuV)	Correct Factor (dB/m)	Near-Field Result (dBuV/m)	Derived Value (dBuV)	Limit (dBuV/m)	Margin (dB)	Remark
1	1.2380	44.49	14.94	59.43	-1.84	25.75	-27.59	QP
2	2.7982	45.19	15.86	61.05	6.87	29.54	-22.67	QP
3	7.2667	39.00	15.56	54.56	8.67	29.54	-20.88	QP
4	9.8460	34.71	15.01	49.72	6.46	29.54	-23.08	QP
5	15.8742	41.49	13.94	55.43	16.32	29.54	-13.23	QP
6	19.4432	36.55	14.29	50.84	13.48	29.54	-16.06	QP

Note: The level is measured at 1 meter and is converted into result at 300 or 30 meter.

**30MHz ~ 1GHz:**

Standard:	FCC Part 15C	Test Distance:	3m
Test item:	Radiated Emission	Power:	AC 120V/60Hz
Model Number:	P530D	Temp.(°C)/Hum.(%RH):	26(°C)/60%RH
Mode:	Mode 2	Date:	10/06/2015
Ant.Polar.:	Horizontal	Test By:	Eric Ou Yang

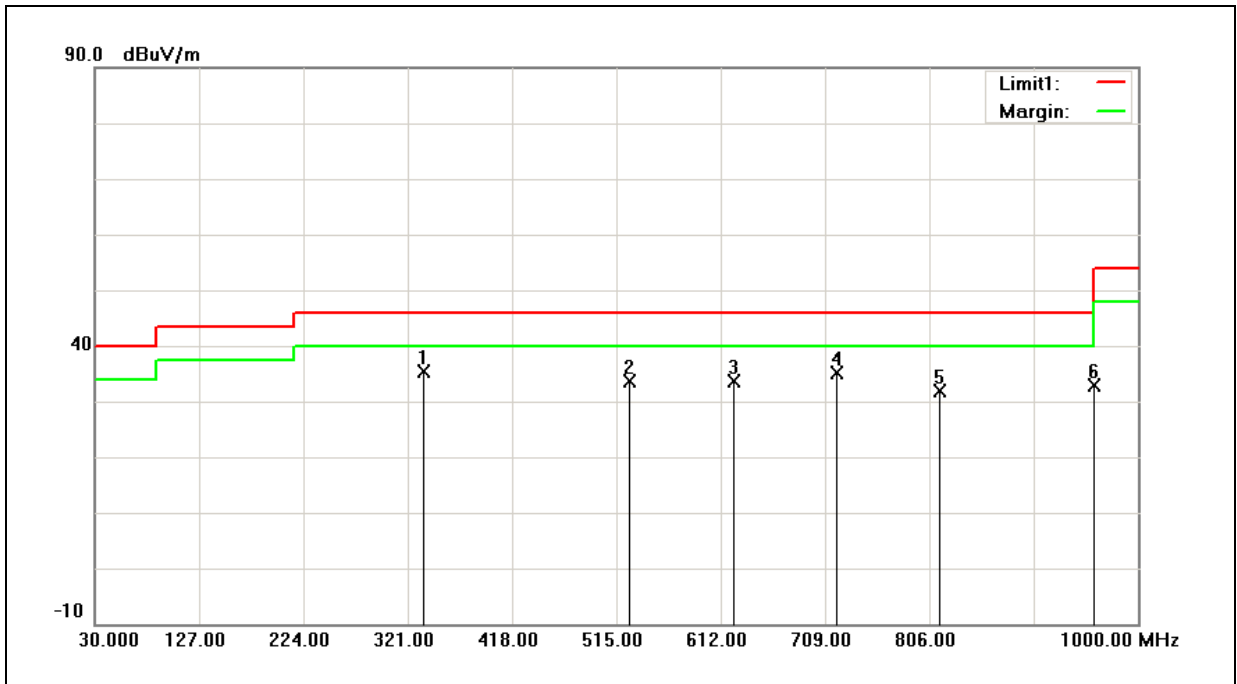

No.	Frequency (MHz)	Reading (dBuV)	Correct Factor (dB/m)	Result (dBuV/m)	Limit (dBuV/m)	Margin (dB)	Remark
1	336.0000	43.25	-7.93	35.32	46.00	-10.68	QP
2	528.0000	38.89	-5.24	33.65	46.00	-12.35	QP
3	624.0000	36.96	-3.32	33.64	46.00	-12.36	QP
4	720.0000	36.88	-1.86	35.02	46.00	-10.98	QP
5	816.0000	32.10	-0.25	31.85	46.00	-14.15	QP
6	960.0000	30.96	2.01	32.97	46.00	-13.03	QP



Standard:	FCC Part 15C	Test Distance:	3m
Test item:	Radiated Emission	Power:	AC 120V/60Hz
Model Number:	P530D	Temp.(°C)/Hum.(%RH):	26(°C)/60%RH
Mode:	Mode 2	Date:	10/06/2015
Ant.Polar.:	Vertical	Test By:	Eric Ou Yang

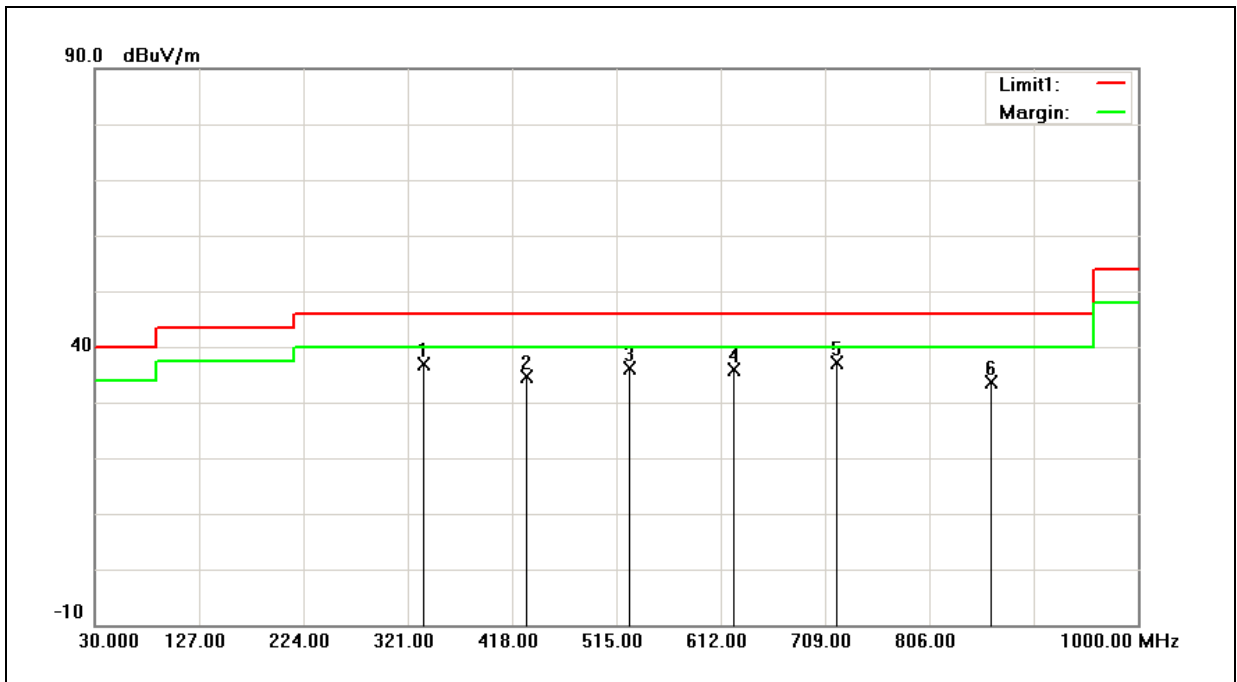

No.	Frequency (MHz)	Reading (dBuV)	Correct Factor (dB/m)	Result (dBuV/m)	Limit (dBuV/m)	Margin (dB)	Remark
1	336.0000	44.69	-7.93	36.76	46.00	-9.24	QP
2	432.0000	41.45	-6.80	34.65	46.00	-11.35	QP
3	528.0000	41.42	-5.24	36.18	46.00	-9.82	QP
4	624.0000	39.21	-3.32	35.89	46.00	-10.11	QP
5	720.0000	39.02	-1.86	37.16	46.00	-8.84	QP
6	864.0000	32.91	0.74	33.65	46.00	-12.35	QP

Standard:	FCC Part 15C	Test Distance:	3m
Test item:	Radiated Emission	Power:	AC 120V/60Hz
Model Number:	P530D	Temp.(°C)/Hum.(%RH):	26(°C)/60%RH
Mode:	Mode 3	Date:	10/06/2015
		Test By:	Eric Ou Yang

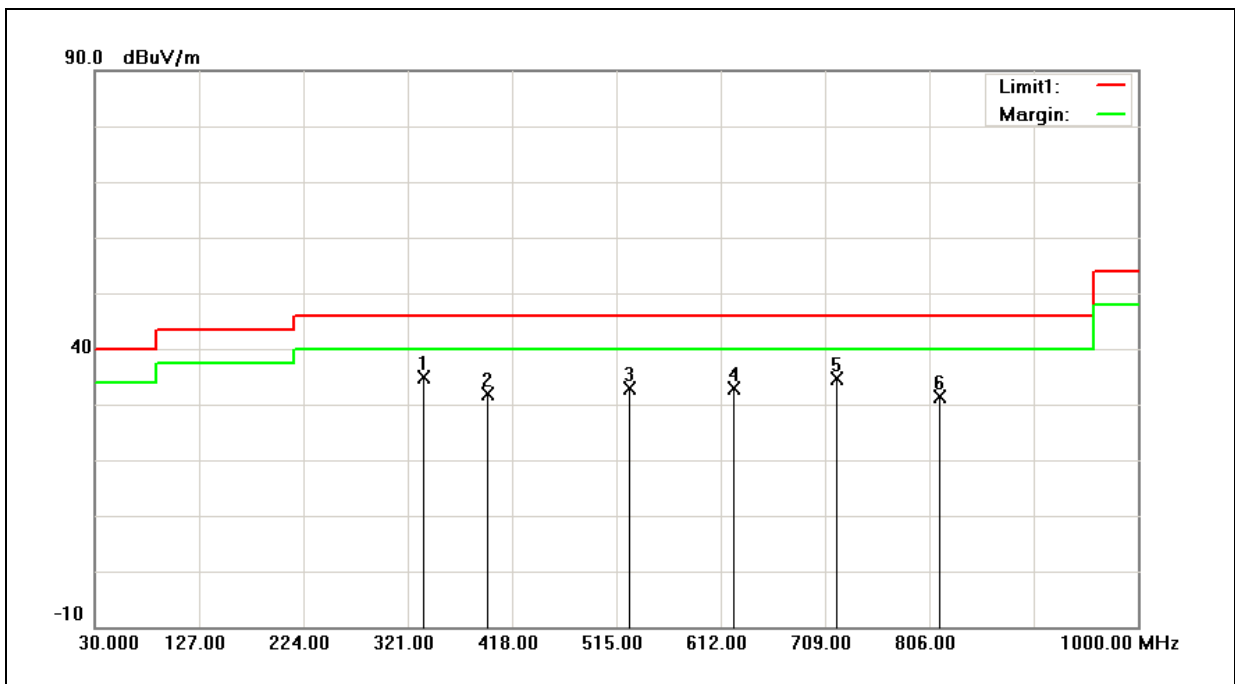

No.	Frequency (MHz)	Reading (dBuV)	Correct Factor (dB/m)	Result (dBuV/m)	Limit (dBuV/m)	Margin (dB)	Remark
1	336.0000	42.87	-7.93	34.94	46.00	-11.06	QP
2	395.0000	39.20	-7.35	31.85	46.00	-14.15	QP
3	528.0000	38.19	-5.24	32.95	46.00	-13.05	QP
4	624.0000	36.24	-3.32	32.92	46.00	-13.08	QP
5	720.0000	36.39	-1.86	34.53	46.00	-11.47	QP
6	816.0000	31.71	-0.25	31.46	46.00	-14.54	QP

Standard:	FCC Part 15C	Test Distance:	3m
Test item:	Radiated Emission	Power:	AC 120V/60Hz
Model Number:	P530D	Temp.(°C)/Hum.(%RH):	26(°C)/60%RH
Mode:	Mode 3	Date:	10/06/2015
Ant.Polar.:	Vertical	Test By:	Eric Ou Yang

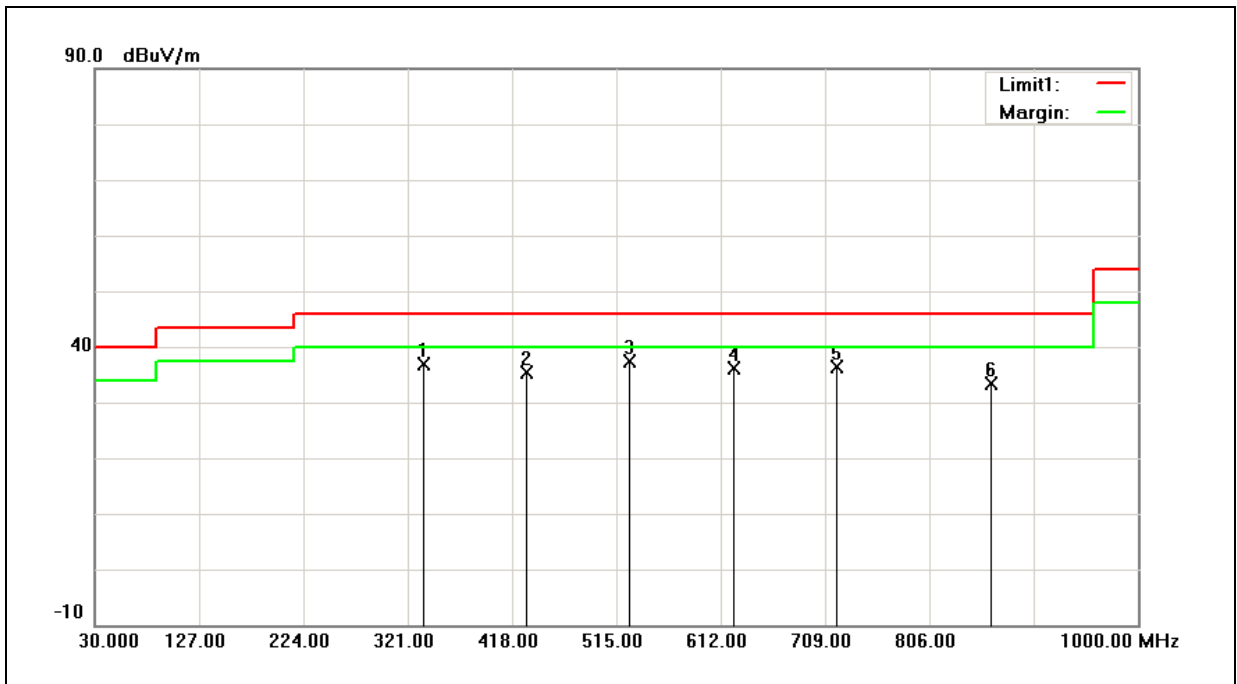

No.	Frequency (MHz)	Reading (dBuV)	Correct Factor (dB/m)	Result (dBuV/m)	Limit (dBuV/m)	Margin (dB)	Remark
1	336.0000	44.73	-7.93	36.80	46.00	-9.20	QP
2	432.0000	42.19	-6.80	35.39	46.00	-10.61	QP
3	528.0000	42.54	-5.24	37.30	46.00	-8.70	QP
4	624.0000	39.40	-3.32	36.08	46.00	-9.92	QP
5	720.0000	38.15	-1.86	36.29	46.00	-9.71	QP
6	864.0000	32.55	0.74	33.29	46.00	-12.71	QP

## 6 Frequency Stability Measurement

### 6.1. Limit

According to §15.207(e), the frequency tolerance of the carrier signal shall be maintained within +/- 0.01% of the operating frequency over a temperature variation of -20 degrees to +50 degrees C at normal supply voltage, and for a variation in the primary supply voltage from 85% to 115% of the rated supply voltage at a temperature of 20 degrees C. For battery operated equipment, the equipment tests shall be performed using a new battery.

### 6.2. Test Setup

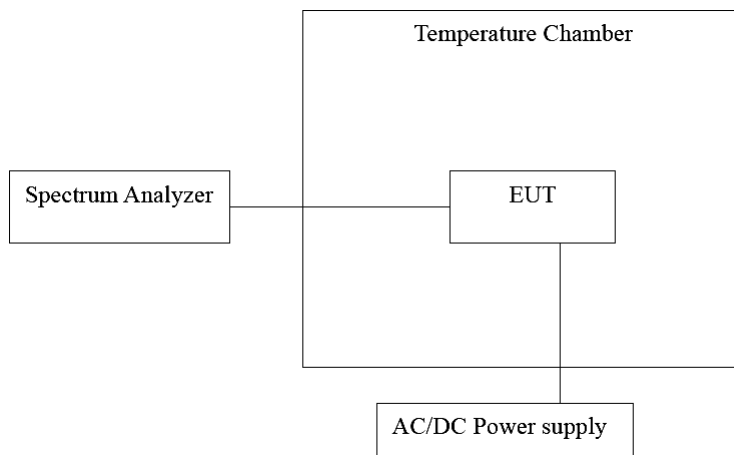

### 6.3. Test Instruments

Equipment	Manufacturer	Model Number	Serial Number	Cal. Date	Remark
Spectrum Analyzer	Agilent	E4408B	MY45107753	07/27/2015	(1)
Temperature & Humidity Chamber	TAICHY	MHU-225LA	980729	04/27/2015	(1)
Test Site	ATL	TE05	TE05	N.C.R.	-----

Remark: <sup>(1)</sup> Calibration period 1 year. <sup>(2)</sup> Calibration period 2 years.

NOTE: N.C.R. = No Calibration Request.

#### 6.4. Test Procedure

1. Place the EUT on the table and set it in the transmitting mode.
2. Remove the antenna from the EUT and then connect a low loss RF cable from the antenna port to the spectrum analyzer.
3. Set the environment into appropriate environment.
4. Set the spectrum analyzer as RBW=1kHz, VBW = RBW, Span = 200kHz, Sweep = auto.
5. Mark the peak frequency and measure the frequency tolerance using frequency counter function.
6. Repeat until all the results are investigated.

#### 6.5. Test Result

##### Temperature Variations

Model Number	P530D					
Mode	Mode 2					
Date of Test	10/06/2015			Test Site	TE05	
Temp. (°C)	Voltage (VAC)	Measured Frequency (MHz)	Delta Frequency (Hz)	Tolerance (%)	Limit (±%)	Result (Pass/Fail)
-20	120	13.5607	680.0000	0.0050	±0.01	Pass
-10		13.5608	840.0000	0.0062	±0.01	Pass
0		13.5604	370.0000	0.0027	±0.01	Pass
10		13.5602	190.0000	0.0014	±0.01	Pass
20		13.5600	0.0000	0.0000	±0.01	Pass
30		13.5609	890.0000	0.0066	±0.01	Pass
40		13.5606	610.0000	0.0045	±0.01	Pass
50		13.5607	700.0000	0.0052	±0.01	Pass

##### Voltage Variations

Model Number	P530D					
Mode	Mode 2					
Date of Test	10/06/2015			Test Site	TE05	
Temp. (°C)	Voltage (VAC)	Measured Frequency (MHz)	Delta Frequency (Hz)	Tolerance (%)	Limit (±%)	Result (Pass/Fail)
20	102	13.5607	710.0000	0.0052	±0.01	Pass
	120	13.5600	0.0000	0.0000	±0.01	Pass
	138	13.5609	940.0000	0.0069	±0.01	Pass

## 7 20dB Bandwidth Measurement

### 7.1. Limit

N/A

### 7.2. Test Setup

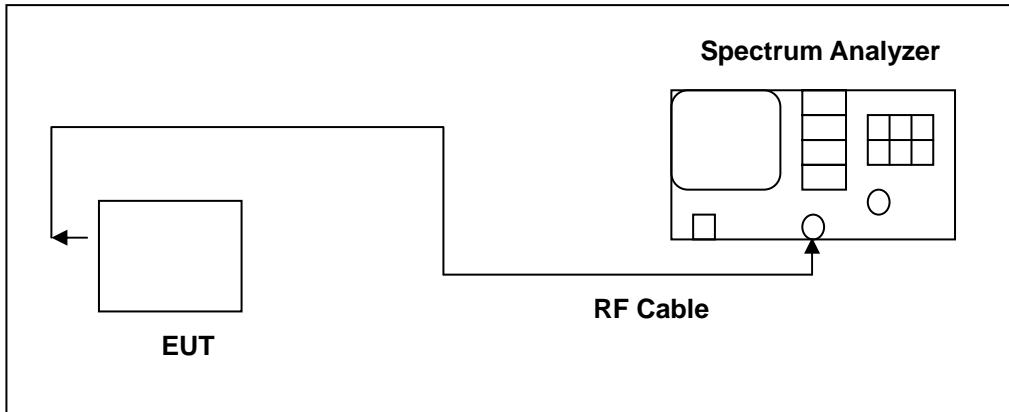

### 7.3. Test Instruments

Equipment	Manufacturer	Model Number	Serial Number	Cal. Date	Remark
Spectrum Analyzer	Agilent	E4445A	MY46181986	05/14/2015	(1)
Test Site	ATL	TE05	TE05	N.C.R.	-----

Remark: <sup>(1)</sup> Calibration period 1 year. <sup>(2)</sup> Calibration period 2 years.

NOTE: N.C.R. = No Calibration Request.

#### 7.4. Test Procedure

Connect RF output port to the input of the spectrum analyzer. Connect the DUT to appropriate power supply.

Turn RFID function of DUT on.

Analyzer used the following settings:

1. Span = 60 kHz
2. RBW  $\geq$  1% of the 20dB span
3. VBW  $\geq$  RBW
4. Sweep = auto
5. Detector function = peak
6. Trace = max hold

The trace was allowed to stabilize. The EUT was transmitting at its maximum data rate. The marker-to-peak function was used to set the marker to the peak of the emission. The marker-delta function was used to measure 20dB down one side of the emission. The marker-delta function and marker was moved to the other side of the emission until it was even with the reference marker. The marker-delta reading at this point was the 20dB bandwidth of the emission.

**7.5. Test Result**

Model Number	P530D		
Mode	Mode 2		
Date of Test	10/22/2015	Test Site	TE05
Frequency (MHz)	Measurement (kHz)		
13.5600	47.935		

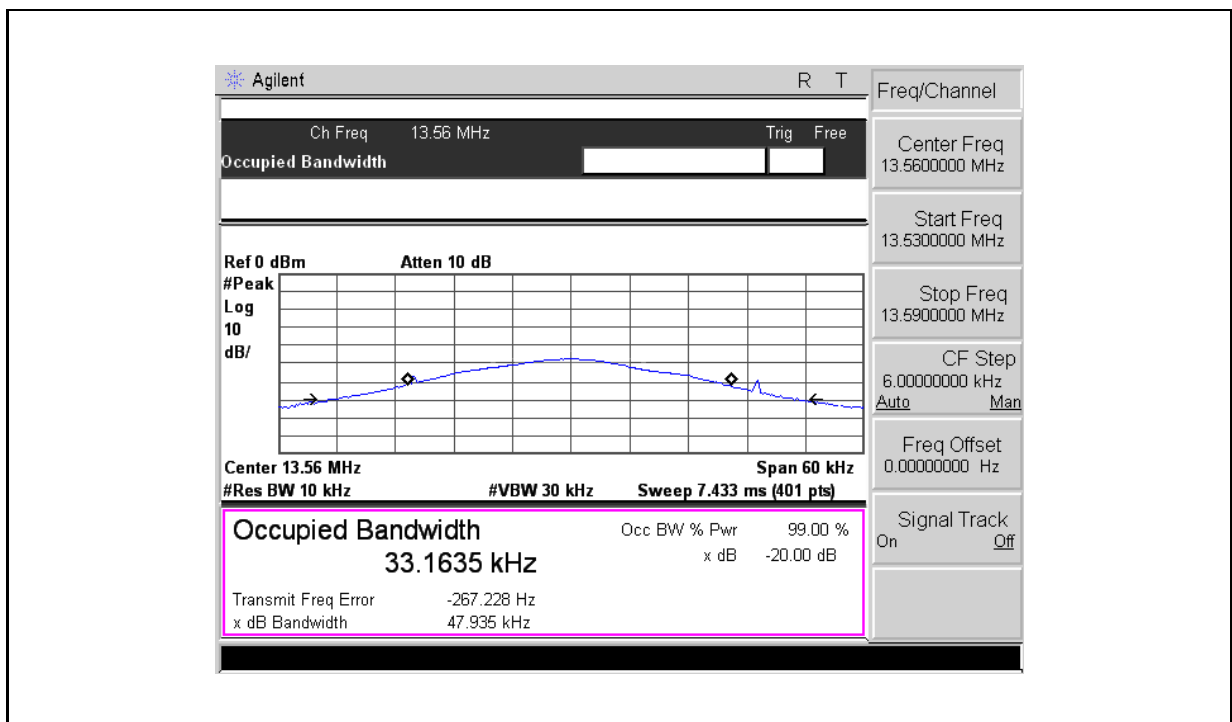
**7.6. Test Graphs**



## **8 Antenna Requirement**

### **8.1. Require**

An intentional radiator shall be designed to ensure that no antenna other than that furnished by the responsible party shall be used with the device. The use of a permanently attached antenna or of an antenna that uses a unique coupling to the intentional radiator shall be considered sufficient to comply with the provisions of this section. The manufacturer may design the unit so that a broken antenna can be replaced by the user, but the use of a standard antenna jack or electrical connector is prohibited.

### **8.2. Antenna Connector Construction**

The antenna connector used in this product is internal antenna, cannot be replaced by the end-user.