

**RALINK TECHNOLOGY, CORP.  
CONFIDENTIAL**

Filename:  
MPCI-RT2561-RT2527-V11TQ-X-061405.DSN

Title		Mini PCI System - RT2561 + RT2527	
Size	Document Number	MPCI-RT2561+RT2527-V11TQ-X.SCH	
B	Rev	OCT.26.2005	
Date:	Tuesday, June 14, 2005	Sheet	1 of 5

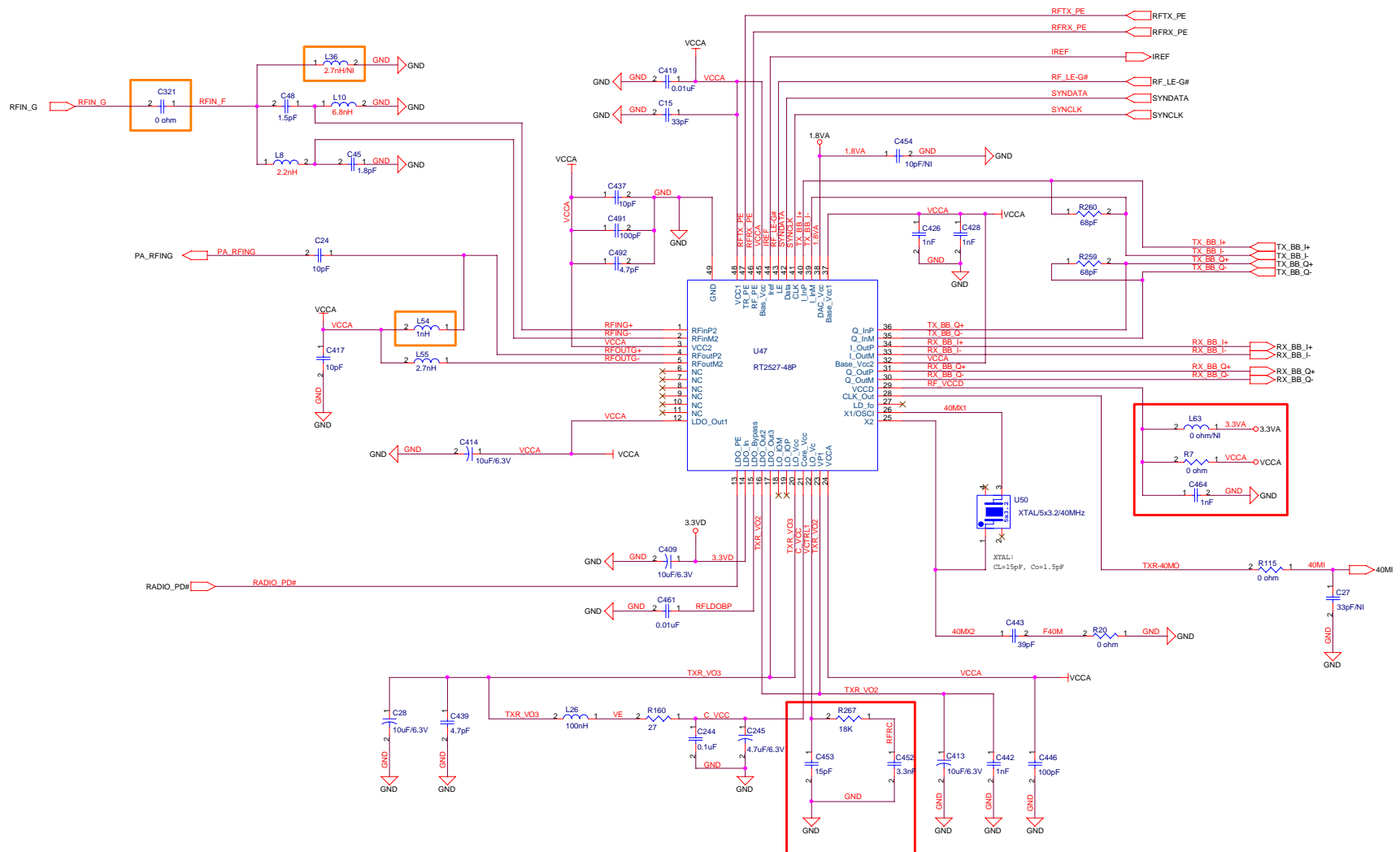



RALINK TECHNOLOGY, CORP.  
CONFIDENTIAL

Title Transceiver - RT2527		
Size C	Document Number 1-RT2527-XTAL SCH	Rev 1.0
Date Thursday, July 14, 2005	Sheet 2	of 5

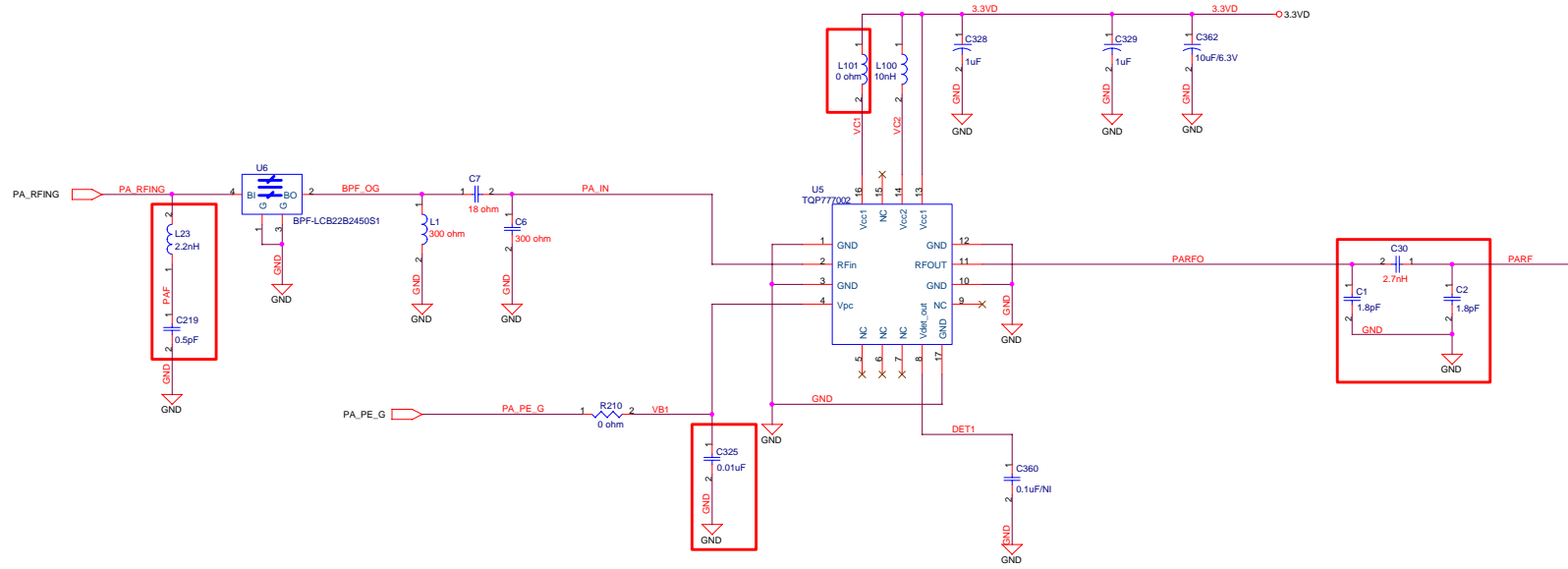
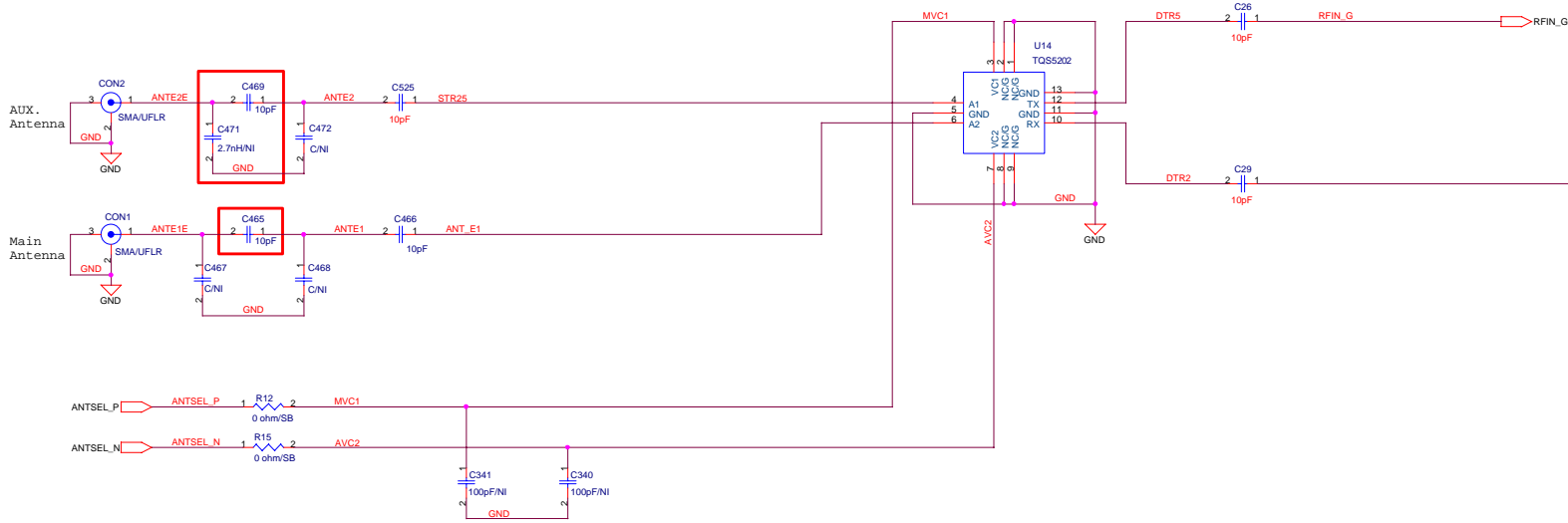

RALINK TECHNOLOGY, CORP.  
CONFIDENTIAL



Title			PA and TX/RX
Size	Document Number	Rev	
C	2-PA-TQM7M70001.SCH	1.0	
Date:	Friday, July 29, 2005	Sheet	3 of 5

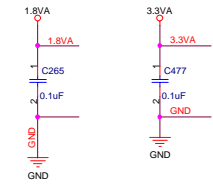
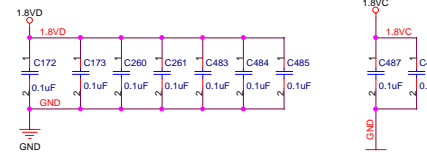
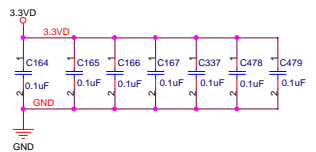
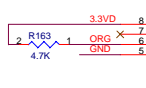
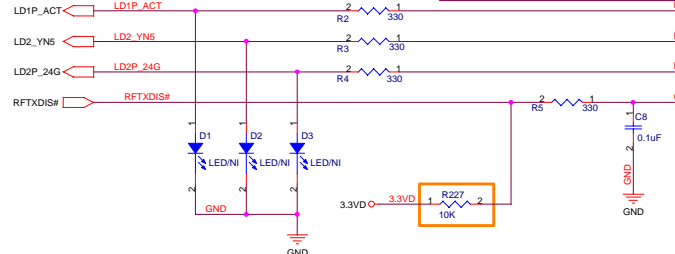
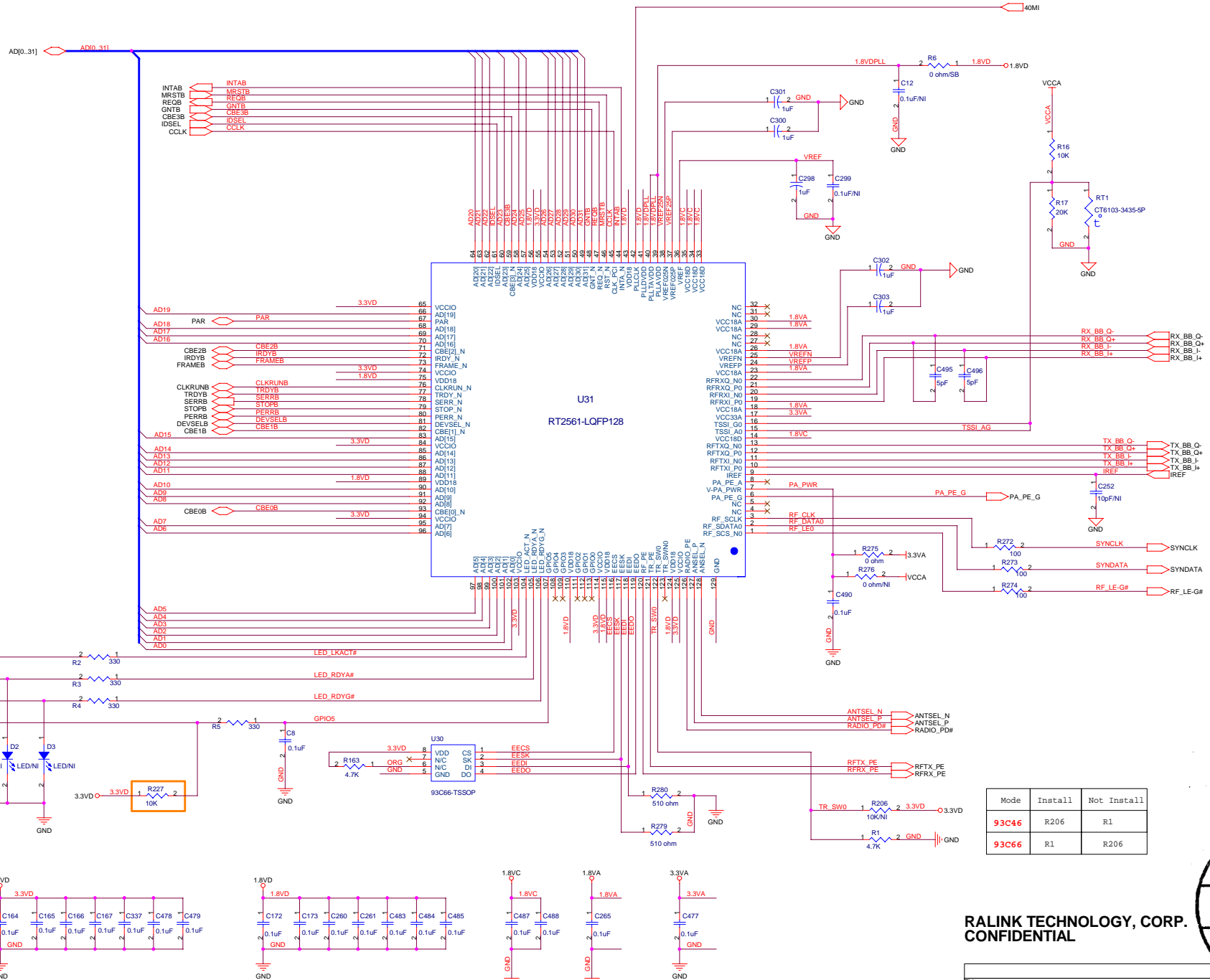
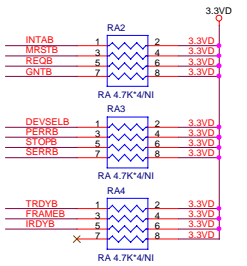

Mode	Install	Not Install
93C46	R206	R1
93C66	R1	R206

RALINK TECHNOLOGY, CORP.  
CONFIDENTIAL

Title: WLAN MAC+BBP - RT2561		
Size: C	Document Number: 3-RT2561-MPC1SCH	Rev: 1.0
Date: Monday, July 04, 2005	Sheet: 4	of 5



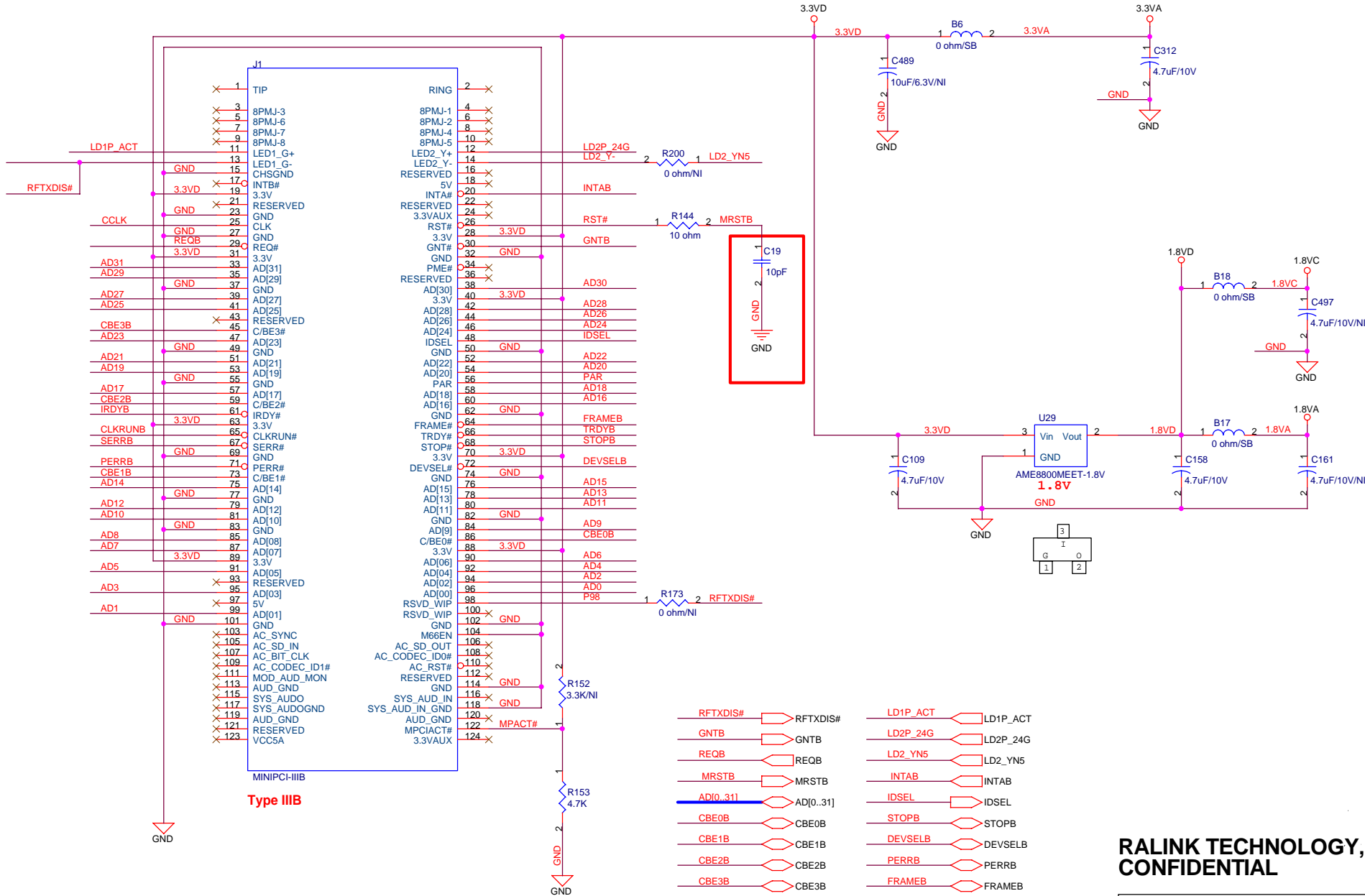

MINIPCI-IIIB  
Type IIIB

- |           |           |          |          |
|-----------|-----------|----------|----------|
| RFTXDIS#  | RFTXDIS#  | LD1P_ACT | LD1P_ACT |
| GNTB      | GNTB      | LD2P_24G | LD2P_24G |
| REQB      | REQB      | LD2_YN5  | LD2_YN5  |
| MRSTB     | MRSTB     | INTAB    | INTAB    |
| AD[0..31] | AD[0..31] | IDSEL    | IDSEL    |
| CBE0B     | CBE0B     | STOPB    | STOPB    |
| CBE1B     | CBE1B     | DEVSELB  | DEVSELB  |
| CBE2B     | CBE2B     | PERRB    | PERRB    |
| CBE3B     | CBE3B     | FRAMEB   | FRAMEB   |
| PAR       | PAR       | SERRB    | SERRB    |
| TRDYB     | TRDYB     | CCLK     | CCLK     |
| IRDYB     | IRDYB     | CLKRUNB  | CLKRUNB  |

**RALINK TECHNOLOGY, CORP.**  
**CONFIDENTIAL**

Title		Mini PCI Interface and Power	
Size	B	Document Number	4-MINIPCI.SCH
Date	Monday, April 25, 2005	Rev	OCT.26.2005
Sheet		5 of 5	

