

Annex no. 5

Functional Description / User Manual

Project Documentation | UMRR-0F0002-200901-070B00 Radar Sensor Documentation

Project Number:

...

SMS Project Number:

Project Title:

General Purpose Radar Sensor

Keyword(s):

UMRR-0F0002-200901-070B00 radar sensor, type 32 antenna

Date:

November 13, 2014

Document:

UMRR-0F0002-200901-070B00 General Purpose USA

Version:

1

CONFIDENTIAL AND PROPRIETARY

The Information contained in this document shall remain the sole exclusive property of s.m.s smart microwave sensors GmbH and shall not be disclosed by the recipient to third parties without prior consent of s.m.s smart microwave sensors GmbH in writing.

1 Contents

1	Contents.....	2
2	Abbreviations.....	3
3	Introduction.....	4
4	General description	5
4.1	Sensor description.....	5
4.2	Transmit Signal.....	7
4.3	General Performance Data.....	7
5	Hardware	8
5.1	UMRR sensor	8
5.2	Sensor Dimensions.....	10
6	Cables and connectors.....	12
6.1	Sensor connector	12
7	Data interfaces	13
7.1	CAN data interface	13
7.2	CAN-Settings	13
7.3	RS485 data interface.....	14
7.4	Transceiver schematics.....	17
8	Designated use	19
9	Change the Frequency Band	20
10	Frequency Approval	22
10.1	Declaration of Conformity for USA.....	22
10.1.1	FCC Label.....	22
10.2	Declaration of Conformity for CANADA	23
10.2.1	Declaration of Conformity in English.....	23
10.2.2	Déclaration de conformité en français	23
10.2.3	Industry Canada (IC) Label	23

CONFIDENTIAL AND PROPRIETARY

The Information contained in this document shall remain the sole exclusive property of s.m.s smart microwave sensors GmbH and shall not be disclosed by the recipient to third parties without prior consent of s.m.s smart microwave sensors GmbH in writing.

2 Abbreviations

ADC	Analog-to-digital converter
CAN	Controller area network
DAC	Digital-to-analog converter
DSP	Digital signal processing; digital signal processor
EEPROM	Electrically erasable programmable read-only memory
FMCW	Frequency modulated continuous wave
MMIC	Monolithic microwave integrated circuit
RAM	Random access memory
RS485	Physical communication layer standard EIA RS-485
SPI	Serial peripheral interface
UMRR	Universal medium-range radar

CONFIDENTIAL AND PROPRIETARY

The Information contained in this document shall remain the sole exclusive property of s.m.s smart microwave sensors GmbH and shall not be disclosed by the recipient to third parties without prior consent of s.m.s smart microwave sensors GmbH in writing.

3 Introduction

This document is a short documentation of the general purpose universal medium range radar (UMRR) UMRR-0F0002 radar sensor with type 32 antenna 200901 in the housing version 070B00.

CONFIDENTIAL AND PROPRIETARY

The Information contained in this document shall remain the sole exclusive property of s.m.s smart microwave sensors GmbH and shall not be disclosed by the recipient to third parties without prior consent of s.m.s smart microwave sensors GmbH in writing.

4 General description

4.1 Sensor description

The main task of the UMRR is the detection of any reflectors in the field of view, to measure the distance, the relative speed and the angle to the shortest reflector (and to other reflectors), to detect motion and to track (filter) the results over time.

For this **general purpose measurement application**, range and relative radial speed and the angle value of each reflector inside the antenna beam are measured and the results are reported via the communication links cycle by cycle. For a block diagram of the sensor see Figure 1.

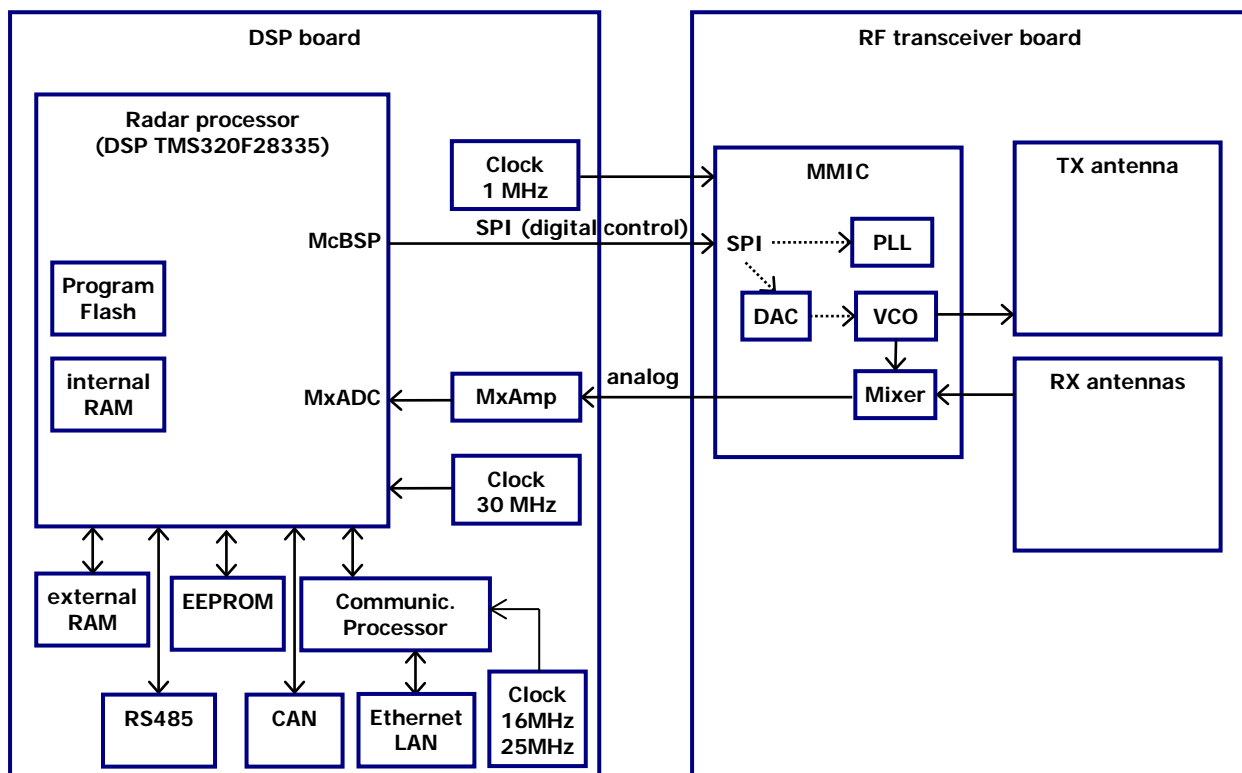

Figure 1: Block diagram of the UMRR-OF sensor

The UMRR sensor consists of two printed circuit boards: The DSP board and the RF transceiver board.

The major component of the DSP board is the DSP TMS320F28335 which integrates flash memory (for program code) and RAM. The DSP provides interfaces to external RAM, EEPROM, CAN bus and RS485 (both for data communication). The Communication Processor provides an Ethernet interface for data communication.

The DSP controls the RF transceiver board via an SPI interface.

CONFIDENTIAL AND PROPRIETARY

The Information contained in this document shall remain the sole exclusive property of s.m.s smart microwave sensors GmbH and shall not be disclosed by the recipient to third parties without prior consent of s.m.s smart microwave sensors GmbH in writing.

The RF transceiver board consists of transmit and receive antennae and the RF circuitry that includes the radar MMIC SC3001.2. The radar MMIC generates the transmit signal and down converts the receive signals into baseband. The analog baseband signals are then routed to the DSP board and digitized by the DSP's built-in ADC. The digital data are further processed on the DSP.

The MMIC also features a PLL circuitry to calibrate and linearize the transmit frequency ramps, a DAC for setting the VCO voltage (corresponding to the transmit frequency) and an SPI interface for receiving the control signals from the DSP.

For the time of emission the device is one fixed point to point application.

CONFIDENTIAL AND PROPRIETARY

The Information contained in this document shall remain the sole exclusive property of s.m.s smart microwave sensors GmbH and shall not be disclosed by the recipient to third parties without prior consent of s.m.s smart microwave sensors GmbH in writing.

4.2 Transmit Signal

The UMRR transmit frequency is located in the 24 GHz ISM band (24075 MHz to 24175 MHz), the used bandwidth is smaller than 100 MHz. The maximum transmit power is 27.0 dBm.

Antenna type 32 is used, consisting of one transmit and two receive antennas, both linear polarized. The 2 way 3 dB cut-off angle in az. $\pm 3.8\text{deg}$. And in el. $\pm 2.5\text{deg}$.

The device uses different FMCW transmit signal waveforms for distance and speed measurement.

4.3 General Performance Data

As soon as the device is powered up, the unit (TX and RX) starts operation. In Table 1: General performance data general performance data are given.

Table 1: General performance data

Environmental		
Ambient Temperature	-40 ... +85	degree C
Shock	100	g _{rms}
Vibration	14	g _{rms}
IP	67	
Pressure / Transport altitude	0...10.000	m
Mechanical		
Weight	870	g
Dimensions	See 5.2	
Housing Identification	070B00	
Antenna Identification	200901	
DSP Board Identification	0F0002	
General		
Power Supply	7 ... 40 3.7	V DC W
Frequency Band	24.075...24.175	GHz
Bandwidth	< 100	MHz
Max. Transmit Power (EIRP)	27.0	dBm
Interfaces	CAN V2.0b (passive), RS485 half or full duplex 100Base-T Ethernet	
Connector	12 Pin plug Hirose LF10WBRB-12PD	CAN, RS485, Power, Eth.

CONFIDENTIAL AND PROPRIETARY

The Information contained in this document shall remain the sole exclusive property of s.m.s smart microwave sensors GmbH and shall not be disclosed by the recipient to third parties without prior consent of s.m.s smart microwave sensors GmbH in writing.

5 Hardware

5.1 UMRR sensor

An example picture of a UMRR (universal medium-range radar) sensor (housing type 070B00) is shown in the figures below.



Figure 2: UMRR sensor, housing type 070B00, front.

CONFIDENTIAL AND PROPRIETARY

The Information contained in this document shall remain the sole exclusive property of s.m.s smart microwave sensors GmbH and shall not be disclosed by the recipient to third parties without prior consent of s.m.s smart microwave sensors GmbH in writing.



Figure 3: UMRR sensor housing 070B00 rear

CONFIDENTIAL AND PROPRIETARY

The Information contained in this document shall remain the sole exclusive property of s.m.s smart microwave sensors GmbH and shall not be disclosed by the recipient to third parties without prior consent of s.m.s smart microwave sensors GmbH in writing.

5.2 Sensor Dimensions

All values given in mm.

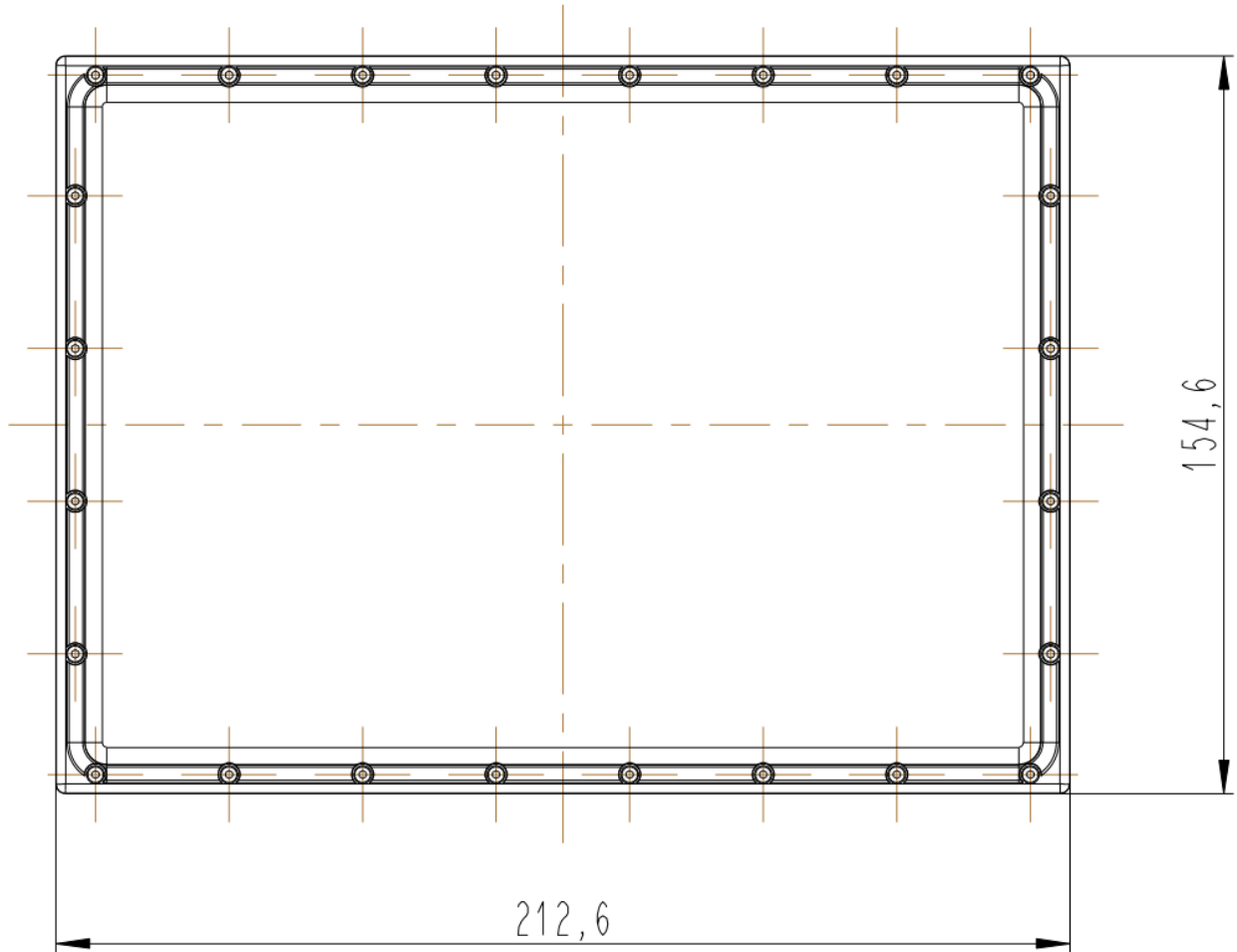

Figure 4: Sensor Front side.

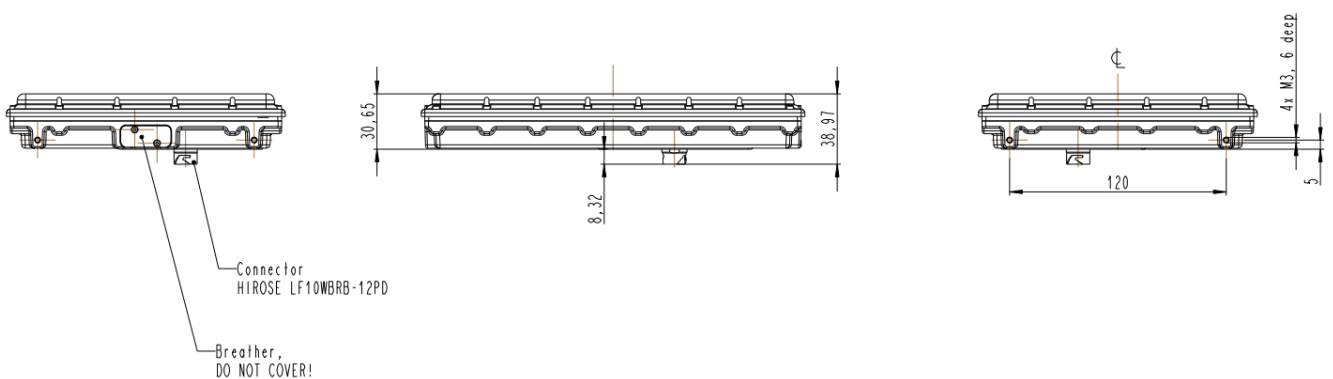

Figure 5: Sensor Top, Left and Right Side.

CONFIDENTIAL AND PROPRIETARY

The Information contained in this document shall remain the sole exclusive property of s.m.s smart microwave sensors GmbH and shall not be disclosed by the recipient to third parties without prior consent of s.m.s smart microwave sensors GmbH in writing.

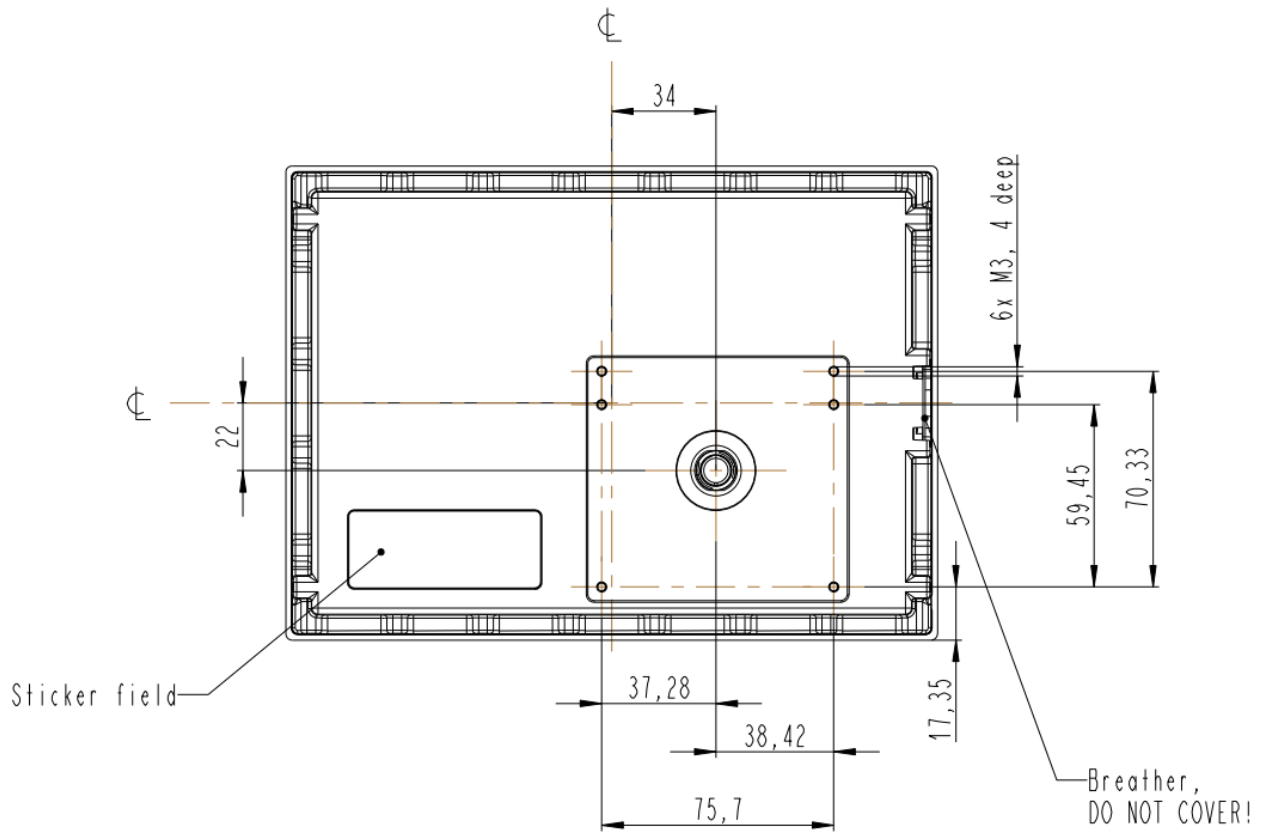

Figure 6: Sensor Rear Side.

CONFIDENTIAL AND PROPRIETARY

The Information contained in this document shall remain the sole exclusive property of s.m.s smart microwave sensors GmbH and shall not be disclosed by the recipient to third parties without prior consent of s.m.s smart microwave sensors GmbH in writing.

6 Cables and connectors

6.1 Sensor connector

The used sensor connector is a 12-pin male (plug) circular connector (water proof IP67, LF10, manufacturer Hirose). A female counterpart (socket), e.g. LF10WBP-12S, has to be used to connect to the sensor. The pin numbering of the socket is shown in Figure 7 the pin description is given in Table 2: Sensor connector pin out Model UMRR-0F0002.

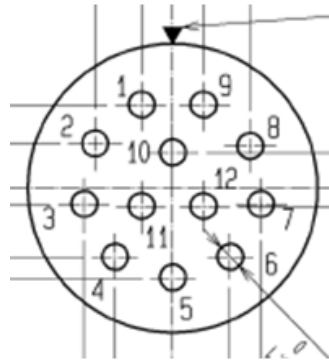

Figure 7: View on solder cup side of socket (rear view of female counterpart to be connected to sensor)

Pin	Signal name	Wire Pair	Function
1	Eth_Tx1_P	1	Ethernet – RJ45 Pin 1
2	Eth_Tx1_N		Ethernet – RJ45 Pin 2
3	RS485_IN_N	2	RS485 Input
4	RS485_IN_P		
5	RS485_OUT_N	3	RS485 Output
6	RS485_OUT_P		
7	GND	4	Ground
8	Vcc		7 .. 40 V DC Supply
9	Eth_Tx2_N	5	Ethernet – RJ45 Pin 6
10	Eth_Tx2_P		Ethernet – RJ45 Pin 3
11	CAN Hi	6	CAN Interface
12	CAN Lo		

Table 2: Sensor connector pin out Model UMRR-0F0002

Please note that in the standard configuration the sensor has no 120Ohms resistor on board (CAN bus termination between CAN_L and CAN_H). The resistor is nevertheless required at either end of a CAN bus and is in most cases integrated in the cable delivered along with the sensor (if cable is manufactured by Smartmicro).

For the RS485 data interface there is a 120Ohms resistor on board of the sensor. The RS485 interface is full duplex hardware. Semi-duplex operation is also supported; please refer to the User Manual.

CONFIDENTIAL AND PROPRIETARY

The Information contained in this document shall remain the sole exclusive property of s.m.s smart microwave sensors GmbH and shall not be disclosed by the recipient to third parties without prior consent of s.m.s smart microwave sensors GmbH in writing.

7 Data interfaces

7.1 CAN data interface

This specification gives a detailed description of the CAN data communication used in the UMRR based systems on the sensor CAN. The UMRR is compliant with CAN 2.0B standard.

CAN is a very robust full duplex bidirectional interface.

7.2 CAN-Settings

Baud Rate:	500kBit/s or lower	
T_{seg1} :	8	
T_{seg2} :	7	
T_{sjw} :	1	(SJW: synchronization jump width)

Above values for CAN bit timing are illustrated in Figure 8 for the DSP TI TMS320F28335 used in the UMRR radar sensor (note: the eCAN module is integrated in the DSP). For comparison purposes, in Figure 9 the CAN bit timing as defined by the CAN protocol is shown. For the DSP TMS320F28335 the value of SYNCSEG (Figure 8) is always equal to 1 TQ (Time Quantum) and it corresponds to the value Sync in Figure 9. TSEG1 (Figure 8) combines the two time segments Prop and Phase 1 (Figure 9) as defined by the CAN protocol. TSEG2 (Figure 8) corresponds to Phase 2 (Figure 9). The CAN bit timing parts as defined by the CAN protocol (Figure 9) can be described as follows:

- **Sync:** This part of bit time is used to synchronize the various nodes on the bus. An edge is expected to lie within this segment. For the UMRR sensor, this segment is always 1 TIME QUANTUM (TQ).
- **Prop:** This part of the bit time is used to compensate for the physical delay times within the network. It is twice the sum of the signal's propagation time on the bus line, the input comparator delay, and the output driver delay. For the UMRR sensor, this segment is programmable from 1 to 8 TIME QUANTA (TQ).
- **Phase 1:** This phase is used to compensate for positive edge phase error. For the UMRR sensor, this segment is programmable from 1 to 8 TIME QUANTA (TQ) and can be lengthened by resynchronization.
- **Phase 2:** This phase is used to compensate for negative edge phase error. For the UMRR sensor, this segment is programmable from 2 to 8 TIME QUANTA (TQ) and can be shortened by resynchronization.

CONFIDENTIAL AND PROPRIETARY

The Information contained in this document shall remain the sole exclusive property of s.m.s smart microwave sensors GmbH and shall not be disclosed by the recipient to third parties without prior consent of s.m.s smart microwave sensors GmbH in writing.

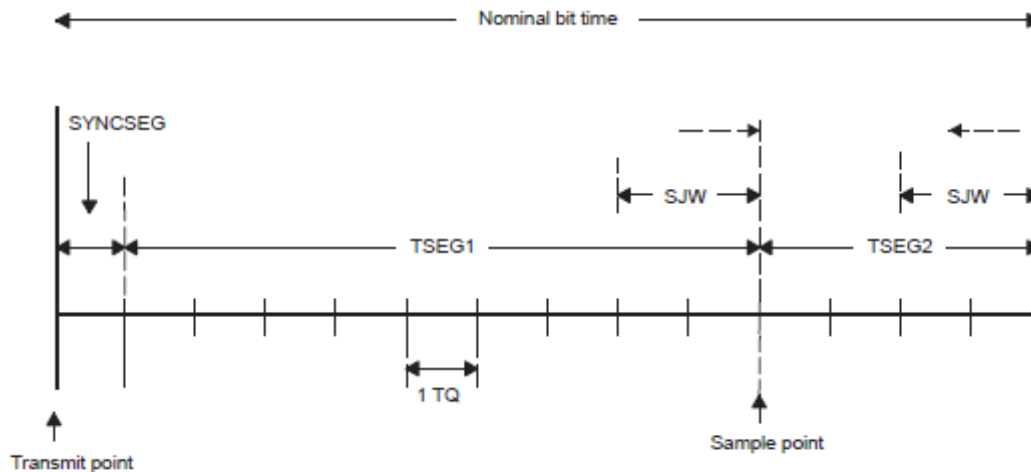

Figure 8: CAN bit timing for UMRR sensor (eCAN module on DSP TMS320F28335)

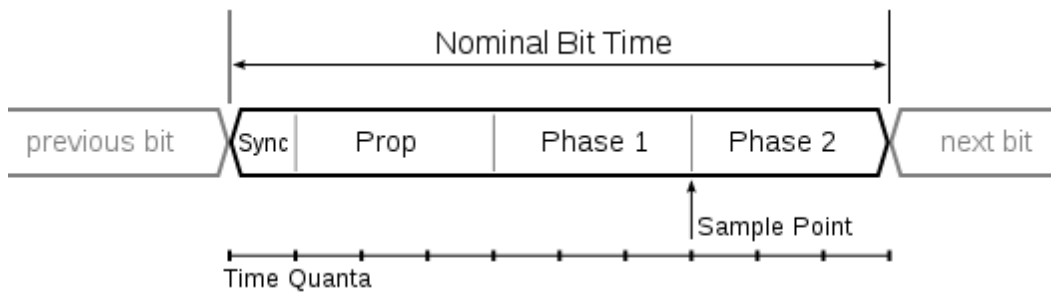

Figure 9: CAN bit timing as defined by the CAN protocol

7.3 RS485 data interface

The RS485 interface from the UMRR sensor has a predefined speed of 230400 baud/s. Typical other data rates are between 921.6kBit/s and 56.7kBit/s.

The RS485 message payload is identical to the CAN format. The data messages will be sent in several packets of one byte.

Every cycle begins with a start sequence and ends with a calculated checksum and an end sequence. The length of the data payload depends on the number of targets and tracked objects.

Every cycle has one start sequence one end sequence and one checksum.

CONFIDENTIAL AND PROPRIETARY

The Information contained in this document shall remain the sole exclusive property of s.m.s smart microwave sensors GmbH and shall not be disclosed by the recipient to third parties without prior consent of s.m.s smart microwave sensors GmbH in writing.

Table 3: RS485 message structure

Byte\Bit	7	6	5	4	3	2	1	0
0	Start sequence (4 x UINT8)							0xCA
1								0xCB
2								0xCC
3								0xCD
x	Data payload (n x UINT8)							
x								
x								
x								
x								
x								
x								
0	XOR Checksum (UINT8)							
1	End sequence (4 x UINT8)							0xEA
2								0xEB
3								0xEC
4								0xED

Every data message consists of its own message ID, the number of used data bytes and the data bytes itself.

The checksum is calculated on all data except the start sequence and the end sequence. The Checksum is a simple XOR Assignment of all n data bytes.
 Byte0 **XOR** Byte1 **XOR** Byte2 ... **XOR** Byte (n-1)

CONFIDENTIAL AND PROPRIETARY

The Information contained in this document shall remain the sole exclusive property of s.m.s smart microwave sensors GmbH and shall not be disclosed by the recipient to third parties without prior consent of s.m.s smart microwave sensors GmbH in writing.

Table 4: Structure of a RS485 data payload block

Byte\Bit	7	6	5	4	3	2	1	0
0	CAN message ID (UINT16)							High
1								Low
2	CAN message length (UINT8)							
3	CAN data payload (length x UINT8)							
4								
5								
6								
7								
8								
9								
10								

The sensor receives only one message per cycle. It is important to wait for the end sequence to send an additional command.

CONFIDENTIAL AND PROPRIETARY

The Information contained in this document shall remain the sole exclusive property of s.m.s smart microwave sensors GmbH and shall not be disclosed by the recipient to third parties without prior consent of s.m.s smart microwave sensors GmbH in writing.

7.4 Transceiver schematics

In Figure 10 an extract of the DSP board schematic of the UMRR is given. As can be seen in this figure, the CAN A pins of the DSP TMS320F28335 are connected to a CAN transceiver which is connected to the pins CAN_A_L and CAN_A_H. Similarly, the RS485 pins of the DSP are connected to a RS485 transceiver, which is connected to the pins RS485_IN_P, RS485_IN_N, RS485_OUT_P and RS485_OUT_N. It should be noted that the mentioned pins CAN_A_L and CAN_A_H correspond to the pins 11 and 12 of the sensor connector described in section 6.1 and that the RS485 pins correspond to pins 3, 4, 5 and 6.

The Pins CoPro_TX0_P, CoPro_TX0_N, CoPro_TXI_P and CoPro_TXI_N are connected to an Ethernet magnetic module, which is connected to the pins CoPro_TX1_N, CoPro_TX1_P, CoPro_TX2_N and CoPro_TX2_P. (please see Figure 11) These pins lead to the pins 1, 2, 9 and 10 of the connector, described in chapter 6.1.

CONFIDENTIAL AND PROPRIETARY

The Information contained in this document shall remain the sole exclusive property of s.m.s smart microwave sensors GmbH and shall not be disclosed by the recipient to third parties without prior consent of s.m.s smart microwave sensors GmbH in writing.

CONFIDENTIAL AND PROPRIETARY

The Information contained in this document shall remain the sole exclusive property of s.m.s smart microwave sensors GmbH and shall not be disclosed by the recipient to third parties without prior consent of s.m.s smart microwave sensors GmbH in writing.

8 Designated use

The UMRR general purpose medium range radar is suitable for any application where the distance to and relative radial speed of large objects has to be measured.

Typical applications are:

Automotive: measure shortest distance to obstacle.

Robotics: measure shortest distance to obstacle.

Security: detect motions and measure distance to moving object.

Traffic management: detect moving objects, count those, measure speed and measure distance to moving object.

Cranes: measure distance to ground.

Aircraft: measure distance to ground.

The detection range depends on object size. Very large reflectors can be detected at a range of more than 500 m.

CONFIDENTIAL AND PROPRIETARY

The Information contained in this document shall remain the sole exclusive property of s.m.s smart microwave sensors GmbH and shall not be disclosed by the recipient to third parties without prior consent of s.m.s smart microwave sensors GmbH in writing.

9 Change the Frequency Band

For some use cases it may be required to run the sensor in a different frequency range than the default one, to avoid interferences in multi sensor system for example.

The sensor provides 7 possible frequency bands (FB6 ... FB12) between 24.075 GHz and 24.175 GHz.

There are two ways to change the sensors frequency band. One way is to change the sensor ID. With the ID the default frequency band changes as well. This change is non-volatile.

The other way is to change the frequency band by hand, while the sensor ID remains the same. These changes are volatile and will be reset to default after power down unless you save them in the EEPROM by sending "Action 136".

To change the frequency band by hand send the command:

- ParNo.: 36
- Value: 6...12 (=frequency index (FI), default = 6 (FI6), see Table 5)
- Action: 65
- Format: Int

then reinitialize the software:

- ParNo.: don't care
- Value: 1
- Action: 130
- Format: Int

Please note that we use a sensor ID dependent frequency offset (25 MHz) by default:

$$\text{Frequency Band} = \text{Frequency Index} + \text{Sensor ID} * \text{Offset}$$

Example: (Sensor ID2; Frequency Index 4)

$$\text{FI4} + 2 * 25 \text{ MHz} = \text{FB8}$$

CONFIDENTIAL AND PROPRIETARY

The Information contained in this document shall remain the sole exclusive property of s.m.s smart microwave sensors GmbH and shall not be disclosed by the recipient to third parties without prior consent of s.m.s smart microwave sensors GmbH in writing.

Table 5: ID dependent frequency offset

f [GHz]	frequency band	frequency index sensor ID0	frequency index sensor ID1	frequency index sensor ID2	frequency index sensor ID3
24.0810	FB6	F16	F14	F12	F10
24.0935	FB7	F17	F15	F13	F11
24.1060	FB8	F18	F16	F14	F12
24.1185	FB9	F19	F17	F15	F13
24.1310	FB10	F110	F18	F16	F14
24.1435	FB11	F111	F19	F17	F15
24.1560	FB12	F112	F110	F18	F16

If you want to disable the sensor ID dependent frequency offset send the following command:

- ParNo.: 8
- Value: 0 (=deactivated, 1= activated (default))
- Action: 20
- Format: Int

If you use two sensors in combination we recommend you to choose frequency bands which are not adjacent in order to avoid any interference, for example:
 FB6 & FB8, FB7 & FB9, ...

CONFIDENTIAL AND PROPRIETARY

The Information contained in this document shall remain the sole exclusive property of s.m.s smart microwave sensors GmbH and shall not be disclosed by the recipient to third parties without prior consent of s.m.s smart microwave sensors GmbH in writing.

10 Frequency Approval

10.1 Declaration of Conformity for USA

This device complies with Part 15 of the FCC Rules. Operation is subject to the following two conditions:

- (1) This device may not cause harmful interference, and
- (2) this device must accept any interference received, including interference that may cause undesired operation.

Usually this is followed by the following FCC caution:

Any changes or modifications not expressly approved by the party responsible for compliance could void the user's authority to operate this equipment.

Note: This equipment has been tested and found to comply with the limits for a Class B digital device, pursuant to Part 15 of the FCC Rules. These limits are designed to provide reasonable protection against harmful interference in a residential installation. This equipment generates, uses and can radiate radio frequency energy and, if not installed and used in accordance with the instructions, may cause harmful interferences to radio communications. However, there is no guarantee that interference will not occur in a particular installation. If this equipment does cause harmful interference to radio or television reception, which can be determined by turning the equipment off and on, the user is encouraged to try to correct the interference by one or more following measures:

- Reorient or relocate the receiving antenna
- Increase the separation between the equipment and receiver
- Connect the equipment into an outlet on a circuit different from that to which the receiver is connected
- Consult the dealer or an experienced radio/TV technician for help.

10.1.1 FCC Label

FCC ID: W34UMRR0F20

Figure 12: FCC ID

CONFIDENTIAL AND PROPRIETARY

The Information contained in this document shall remain the sole exclusive property of s.m.s smart microwave sensors GmbH and shall not be disclosed by the recipient to third parties without prior consent of s.m.s smart microwave sensors GmbH in writing.

10.2 Declaration of Conformity for CANADA

10.2.1 Declaration of Conformity in English

This device complies with Industry Canada licence-exempt RSS standard(s).

Operation is subject to the following two conditions:

(1) this device may not cause interference, and (2) this device must accept any interference, including interference that may cause undesired operation of the device.

IC Radiation Exposure Statement:

This equipment complies with IC RSS-102 radiation exposure limits set forth for an uncontrolled environment. This equipment should be installed and operated with the minimum distance 20cm between the radiator & your body.

10.2.2 Déclaration de conformité en français

Le présent appareil est conforme aux CNR d'Industrie Canada applicables aux appareils radio exempts de licence. L'exploitation est autorisée aux deux conditions suivantes: (1) l'appareil ne doit pas produire de brouillage, et (2) l'utilisateur de l'appareil doit accepter tout brouillage radioélectrique subi, même si le brouillage est susceptible d'en compromettre le fonctionnement.

DÉCLARATION D'EXPOSITION AUX RADIATIONS

Cet équipement est conforme aux limites d'exposition aux rayonnements IC établies pour un environnement non contrôlé. Cet équipement doit être installé et utilisé avec un minimum de 20cm de distance entre la source de rayonnement et votre corps.

10.2.3 Industry Canada (IC) Label

Model: **UMRR-0F0002-200901-070B00**

Figure 13: Label IC Model (Sample)

IC: 10652A-UMRR0F20

Figure 14: Label IC Number

CONFIDENTIAL AND PROPRIETARY

The Information contained in this document shall remain the sole exclusive property of s.m.s smart microwave sensors GmbH and shall not be disclosed by the recipient to third parties without prior consent of s.m.s smart microwave sensors GmbH in writing.