

# **Annex no. 5**

# **Functional Description / User Manual**

## Project Documentation | UMRR-0A Radar Sensor Documentation

---

**Project Number:**

...

**SMS Project Number:**

**Project Title:**

General Purpose Radar Sensor

**Keyword(s):**

UMRR-0A radar sensor, type 31 antenna

**Date:**

October 4, 2012

**Document:**

UMRR-0Axxxx Type31 General Purpose.docx

**Version:**

1

**CONFIDENTIAL AND PROPRIETARY**

The Information contained in this document shall remain the sole exclusive property of s.m.s smart microwave sensors GmbH and shall not be disclosed by the recipient to third parties without prior consent of s.m.s smart microwave sensors GmbH in writing.

# 1 Contents

- 1 Contents.....
- 2 Abbreviations.....
- 3 Introduction.....
- 4 General description .....
- 4.1 Sensor description.....
  
- 5 Hardware .....
- 5.1 UMRR sensor.....
- 5.2 Sensor Dimensions.....
- 6 Cables and connectors.....
- 6.1 Sensor connector .....
- 7 Data interfaces .....
- 7.1 CAN data interface .....
- 7.2 CAN-Settings .....
- 7.3 RS485 data interface .....
- 7.4 Transceiver schematics.....
- 8 Designated use .....
- 9 Declaration of Conformity for USA.....
- 9.1 FCC Label .....
- 10 Declaration of Conformity for CANADA .....

**CONFIDENTIAL AND PROPRIETARY**

The Information contained in this document shall remain the sole exclusive property of s.m.s smart microwave sensors GmbH and shall not be disclosed by the recipient to third parties without prior consent of s.m.s smart microwave sensors GmbH in writing.

## 2 Abbreviations

ADC	Analog-to-digital converter
CAN	Controller area network
DAC	Digital-to-analog converter
DSP	Digital signal processing; digital signal processor
EEPROM	Electrically erasable programmable read-only memory
FMCW	Frequency modulated continuous wave
MMIC	Monolithic microwave integrated circuit
RAM	Random access memory
RS485	Physical communication layer standard EIA RS-485
SPI	Serial peripheral interface
UMRR	Universal medium-range radar

### **CONFIDENTIAL AND PROPRIETARY**

The Information contained in this document shall remain the sole exclusive property of s.m.s smart microwave sensors GmbH and shall not be disclosed by the recipient to third parties without prior consent of s.m.s smart microwave sensors GmbH in writing.

### **3 Introduction**

This document is a short documentation of the general purpose universal medium range radar (UMRR) UMRR-0Axxxx radar sensor with type 31 antenna in the housing version 0306xx.

#### **CONFIDENTIAL AND PROPRIETARY**

The Information contained in this document shall remain the sole exclusive property of s.m.s smart microwave sensors GmbH and shall not be disclosed by the recipient to third parties without prior consent of s.m.s smart microwave sensors GmbH in writing.

## 4 General description

### 4.1 Sensor description

The main task of the UMRR is the detection of any reflectors in the field of view, to measure the distance, the relative speed and the angle to the shortest reflector (and to other reflectors), to detect motion and to track (filter) the results over time.

For this **general purpose measurement application**, range and relative radial speed and the angle value of each reflector inside the antenna beam are measured and the results are reported via the communication links cycle by cycle. For a block diagram of the sensor see

#### CONFIDENTIAL AND PROPRIETARY

The Information contained in this document shall remain the sole exclusive property of s.m.s smart microwave sensors GmbH and shall not be disclosed by the recipient to third parties without prior consent of s.m.s smart microwave sensors GmbH in writing.

## 5 Hardware

### 5.1 UMRR sensor

An example picture of a UMRR (universal medium-range radar) sensor (housing type 0306xx) is shown in the figures below.

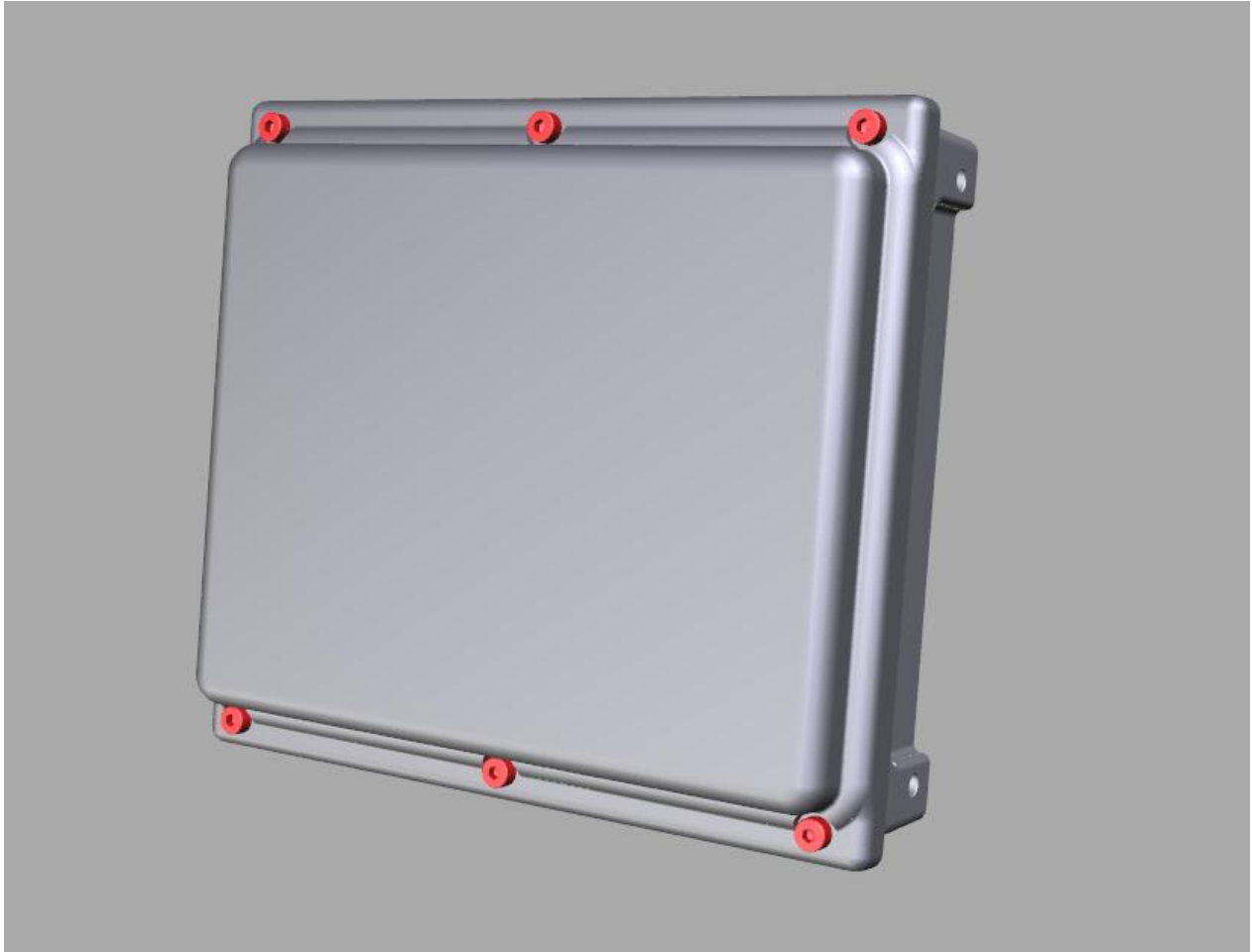

**Figure 2: UMRR sensor, housing type 0306xx, front.**

#### **CONFIDENTIAL AND PROPRIETARY**

The Information contained in this document shall remain the sole exclusive property of s.m.s smart microwave sensors GmbH and shall not be disclosed by the recipient to third parties without prior consent of s.m.s smart microwave sensors GmbH in writing.



**Figure 3: UMR sensor housing 0306xx rear**

**CONFIDENTIAL AND PROPRIETARY**

The Information contained in this document shall remain the sole exclusive property of s.m.s smart microwave sensors GmbH and shall not be disclosed by the recipient to third parties without prior consent of s.m.s smart microwave sensors GmbH in writing.



## 5.2 Sensor Dimensions

All values given in mm.

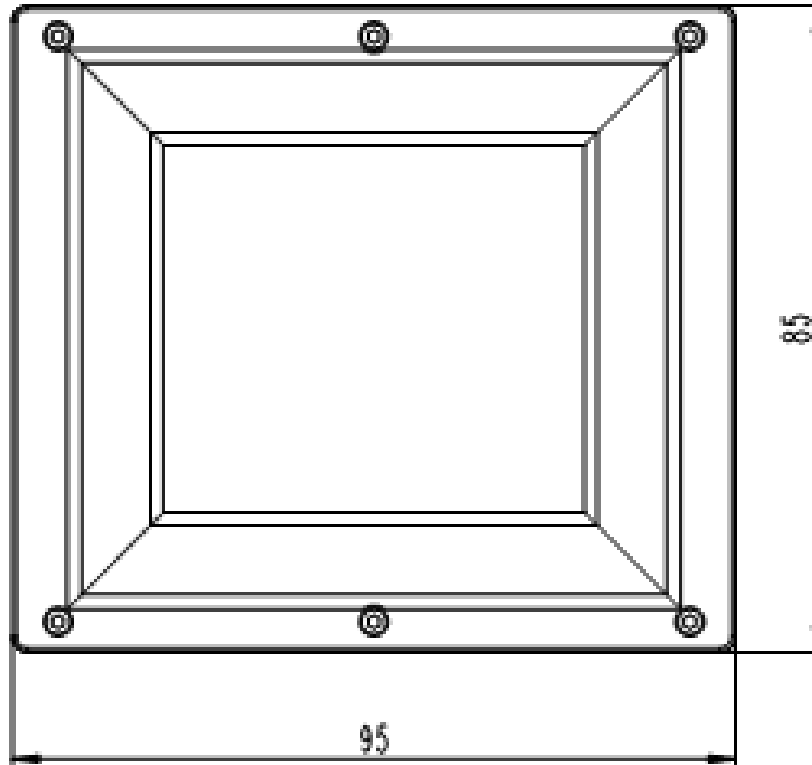

**Figure 4: Sensor Front side.**

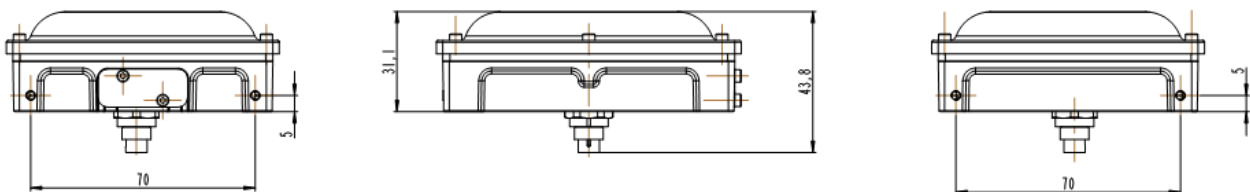

**Figure 5: Sensor Top, Left and Right Side.**

### CONFIDENTIAL AND PROPRIETARY

The Information contained in this document shall remain the sole exclusive property of s.m.s smart microwave sensors GmbH and shall not be disclosed by the recipient to third parties without prior consent of s.m.s smart microwave sensors GmbH in writing.

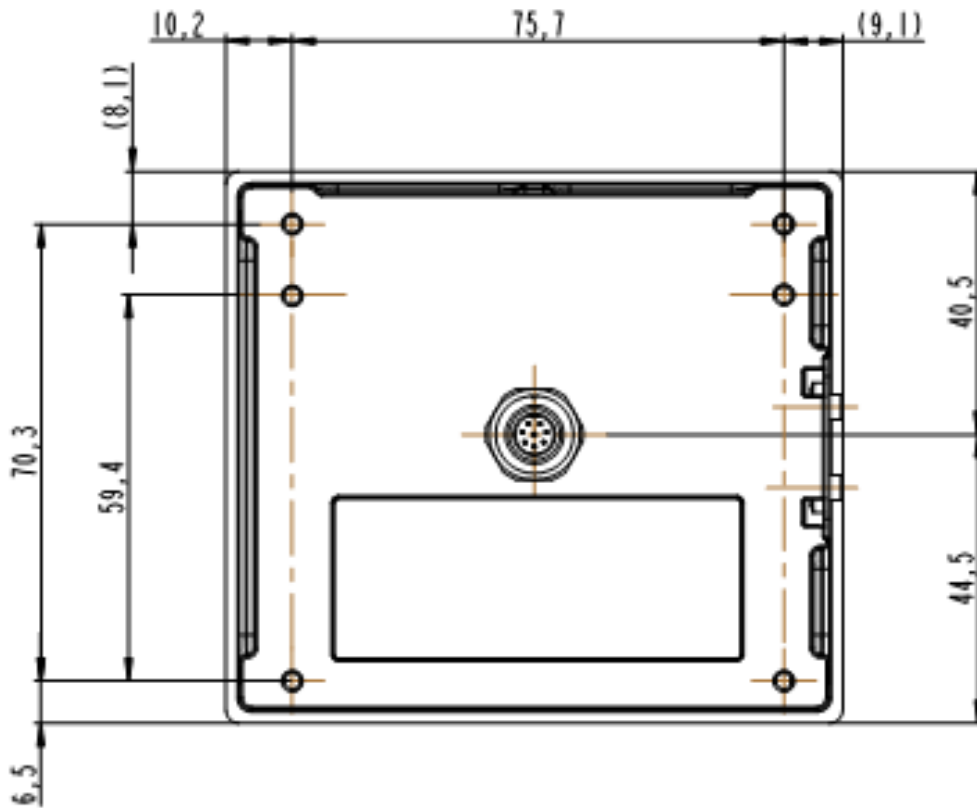

**Figure 6: Sensor Rear Side.**

**CONFIDENTIAL AND PROPRIETARY**

The Information contained in this document shall remain the sole exclusive property of s.m.s smart microwave sensors GmbH and shall not be disclosed by the recipient to third parties without prior consent of s.m.s smart microwave sensors GmbH in writing.

## 6 Cables and connectors

### 6.1 Sensor connector

The used sensor connector is an 8-pin male circular connector (water proof IP67, series 712, manufacturer Binder GmbH, Germany). A female counterpart has to be used to connect to the sensor. The pin numbering of the female connector is shown in Figure 7 the pin out of the connector is shown in Table 2.

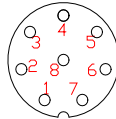

**Figure 7: Female counterpart of sensor connector (rear view)**

Pin	Function	Wire color
1	RS485 L	Pink = RS_485_L
2	Ground	Blue = GND
3	RS485 H	Grey = RS_485_H
4	CAN_L	Yellow = CAN_L
5	CAN_H	Green = CAN_H
6	not connected	Brown = n.c.
7	+7V...+32V	Red = Vcc (+7V...+32V)
8	not connected	White = n.c.

**Table 2: Sensor connector pin out Model UMRR-0Axxxx**

Please note that in the standard configuration the sensor has no 120Ohms resistor on board (CAN bus termination between CAN\_L and CAN\_H). The resistor is nevertheless required at either end of a CAN bus and is in most cases integrated in the cable delivered along with the sensor (if cable is manufactured by Smartmicro).

#### CONFIDENTIAL AND PROPRIETARY

The Information contained in this document shall remain the sole exclusive property of s.m.s smart microwave sensors GmbH and shall not be disclosed by the recipient to third parties without prior consent of s.m.s smart microwave sensors GmbH in writing.

## 7 Data interfaces

### 7.1 CAN data interface

This specification gives a detailed description of the CAN data communication used in the UMRR based systems on the sensor CAN. The UMRR is compliant with CAN 2.0B standard.

CAN is a very robust full duplex bidirectional interface.

### 7.2 CAN-Settings

Baud Rate:	500kBit/s or lower	
$T_{\text{seg1}}$ :	8	
$T_{\text{seg2}}$ :	7	
$T_{\text{sjw}}$ :	1	(SJW: synchronization jump width)

Above values for CAN bit timing are illustrated in Figure 8 for the DSP TI TMS320F28335 used in the UMRR radar sensor (note: the eCAN module is integrated in the DSP). For comparison purposes, in Figure 9 the CAN bit timing as defined by the CAN protocol is shown. For the DSP TMS320F28335 the value of SYNCSEG (Figure 8) is always equal to 1 TQ (Time Quantum) and it corresponds to the value Sync in Figure 9. TSEG1 (Figure 8) combines the two time segments Prop and Phase 1 (Figure 9) as defined by the CAN protocol. TSEG2 (Figure 8) corresponds to Phase 2 (Figure 9) The CAN bit timing parts as defined by the CAN protocol (Figure 9) can be described as follows:

- **Sync:** This part of bit time is used to synchronize the various nodes on the bus. An edge is expected to lie within this segment. For the UMRR sensor, this segment is always 1 TIME QUANTUM (TQ).
- **Prop:** This part of the bit time is used to compensate for the physical delay times within the network. It is twice the sum of the signal's propagation time on the bus line, the input comparator delay, and the output driver delay. For the UMRR sensor, this segment is programmable from 1 to 8 TIME QUANTA (TQ).
- **Phase 1:** This phase is used to compensate for positive edge phase error. For the UMRR sensor, this segment is programmable from 1 to 8 TIME QUANTA (TQ) and can be lengthened by resynchronization.
- **Phase 2:** This phase is used to compensate for negative edge phase error. For the UMRR sensor, this segment is programmable from 2 to 8 TIME QUANTA (TQ) and can be shortened by resynchronization.

#### CONFIDENTIAL AND PROPRIETARY

The Information contained in this document shall remain the sole exclusive property of s.m.s smart microwave sensors GmbH and shall not be disclosed by the recipient to third parties without prior consent of s.m.s smart microwave sensors GmbH in writing.

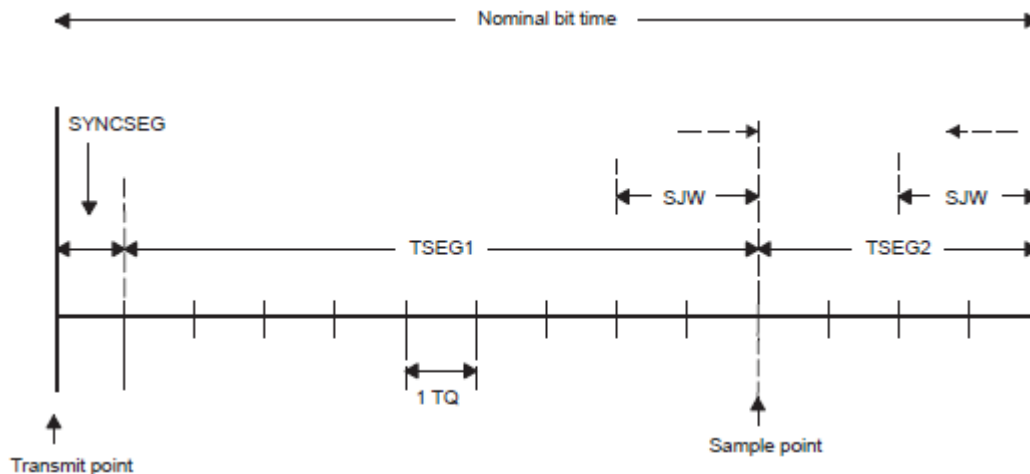

**Figure 8: CAN bit timing for UMRR sensor (eCAN module on DSP TMS320F28335)**

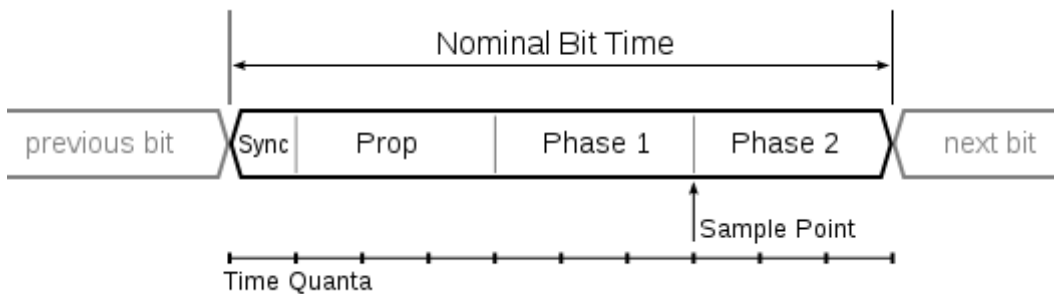

**Figure 9: CAN bit timing as defined by the CAN protocol**

### 7.3 RS485 data interface

The RS485 interface from the UMRR sensor has a predefined speed of 230400 baud/s. Typical other data rates are between 921.6kBit/s and 56.7kBit/s.

The RS485 message payload is identical to the CAN format. The data messages will be sent in several packets of one byte.

Every cycle begins with a start sequence and ends with a calculated checksum and an end sequence. The length of the data payload depends on the number of targets and tracked objects.

Every cycle has one start sequence one end sequence and one checksum.

#### CONFIDENTIAL AND PROPRIETARY

The Information contained in this document shall remain the sole exclusive property of s.m.s smart microwave sensors GmbH and shall not be disclosed by the recipient to third parties without prior consent of s.m.s smart microwave sensors GmbH in writing.

**Table 3: RS485 message structure**

Byte\Bit	7	6	5	4	3	2	1	0
<b>0</b>	Start sequence (4 x UINT8)							0xCA
<b>1</b>								0xCB
<b>2</b>								0xCC
<b>3</b>								0xCD
<b>x</b>	Data payload (n x UINT8)							
<b>x</b>								
<b>x</b>								
<b>x</b>								
<b>x</b>								
<b>x</b>								
<b>x</b>								
<b>0</b>	XOR Checksum (UINT8)							
<b>1</b>	End sequence (4 x UINT8)							0xEA
<b>2</b>								0xEB
<b>3</b>								0xEC
<b>4</b>								0xED

Every data message consists of its own message ID, the number of used data bytes and the data bytes itself.

The checksum is calculated on all data except the start sequence and the end sequence. The Checksum is a simple XOR Assignment of all n data bytes.  
 Byte0 **XOR** Byte1 **XOR** Byte2 ... **XOR** Byte (n-1)

**CONFIDENTIAL AND PROPRIETARY**

The Information contained in this document shall remain the sole exclusive property of s.m.s smart microwave sensors GmbH and shall not be disclosed by the recipient to third parties without prior consent of s.m.s smart microwave sensors GmbH in writing.

**Table 4: Structure of a RS485 data payload block**

Byte\Bit	7	6	5	4	3	2	1	0
<b>0</b>	CAN message ID (UINT16)							High
<b>1</b>								Low
<b>2</b>	CAN message length (UINT8)							
<b>3</b>	CAN data payload (length x UINT8)							
<b>4</b>								
<b>5</b>								
<b>6</b>								
<b>7</b>								
<b>8</b>								
<b>9</b>								
<b>10</b>								

The sensor receives only one message per cycle. It is important to wait for the end sequence to send an additional command.

**CONFIDENTIAL AND PROPRIETARY**

The Information contained in this document shall remain the sole exclusive property of s.m.s smart microwave sensors GmbH and shall not be disclosed by the recipient to third parties without prior consent of s.m.s smart microwave sensors GmbH in writing.

### 7.4 Transceiver schematics

In Figure 10 an extract of the DSP board schematic of the UMRR is given. As can be seen in this figure, the CAN pins of the DSP TMS320F28335 are connected to a CAN transceiver which is connected to the pins CAN\_L and CAN\_H. Similarly, the RS485 pins of the DSP are connected to a RS485 transceiver, which is connected to the pins RS\_485\_L and RS\_485\_H. It should be noted that the mentioned pins CAN\_L and CAN\_H correspond to the pins 4 and 5 of the sensor connector described in section 6.1 and that the pins RS\_485\_L and RS\_485\_H correspond to pins 1 and 3.

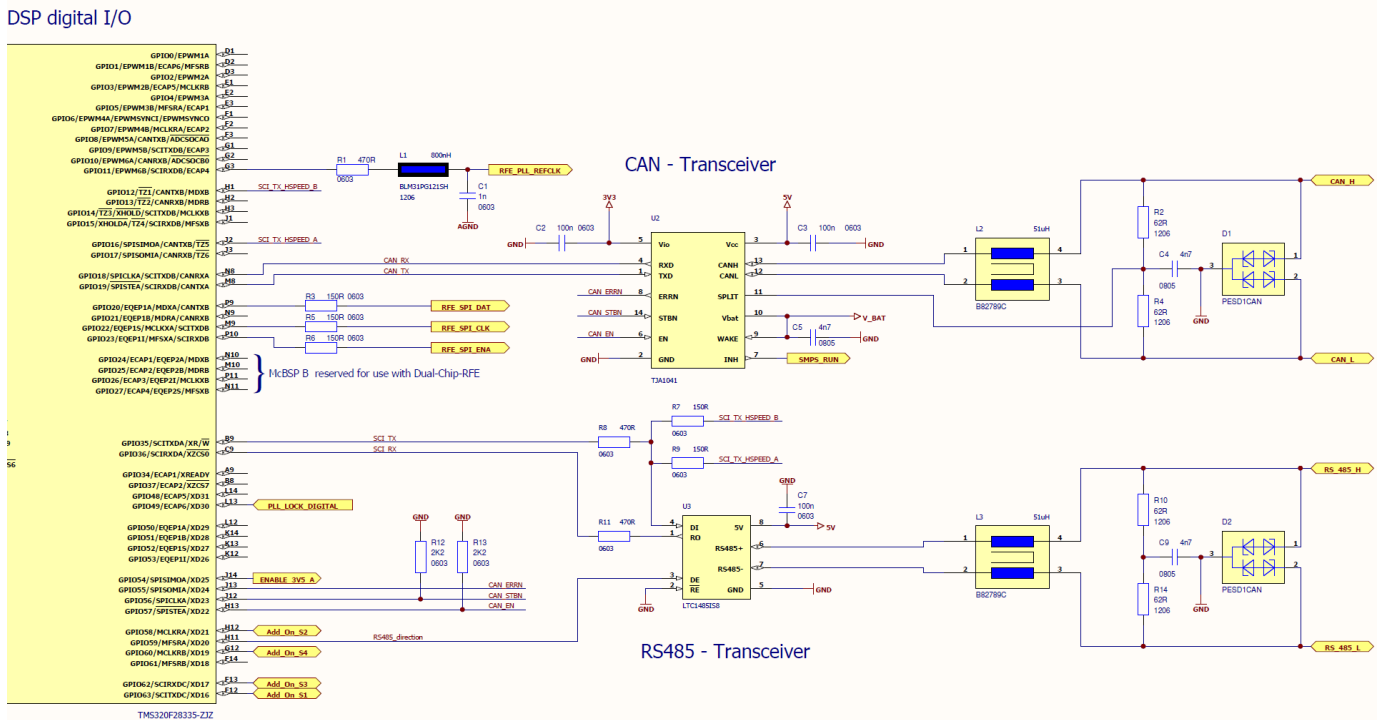

Figure 10: UMRR-0Axxxx DSP board schematics: CAN and RS485 transceivers

**CONFIDENTIAL AND PROPRIETARY**

The Information contained in this document shall remain the sole exclusive property of s.m.s smart microwave sensors GmbH and shall not be disclosed by the recipient to third parties without prior consent of s.m.s smart microwave sensors GmbH in writing.



## **8 Designated use**

The UMRR general purpose medium range radar is suitable for any application where the distance to and relative radial speed of large objects has to be measured.

Typical applications are:

Automotive: measure shortest distance to obstacle.

Robotics: measure shortest distance to obstacle.

Security: detect motions and measure distance to moving object.

Traffic management: detect moving objects, count those, measure speed and measure distance to moving object.

Cranes: measure distance to ground.

Aircraft: measure distance to ground.

The detection range depends on object size. Very large reflectors can be detected at a range of more than 500 m.

### **CONFIDENTIAL AND PROPRIETARY**

The Information contained in this document shall remain the sole exclusive property of s.m.s smart microwave sensors GmbH and shall not be disclosed by the recipient to third parties without prior consent of s.m.s smart microwave sensors GmbH in writing.

## 9 Declaration of Conformity for USA

This device complies with Part 15 of the FCC Rules. Operation is subject to the following two conditions:

- (1) This device may not cause harmful interference, and
- (2) this device must accept any interference received, including interference that may cause undesired operation.

Usually this is followed by the following FCC caution:

Any changes or modifications not expressly approved by the party responsible for compliance could void the user's authority to operate this equipment.

Note: This equipment has been tested and found to comply with the limits for a Class B digital device, pursuant to Part 15 of the FCC Rules. These limits are designed to provide reasonable protection against harmful interference in a residential installation. This equipment generates, uses and can radiate radio frequency energy and, if not installed and used in accordance with the instructions, may cause harmful interferences to radio communications. However, there is no guarantee that interference will not occur in a particular installation. If this equipment does cause harmful interference to radio or television reception, which can be determined by turning the equipment off and on, the user is encouraged to try to correct the interference by one or more following measures:

- Reorient or relocate the receiving antenna
- Increase the separation between the equipment and receiver
- Connect the equipment into an outlet on a circuit different from that to which the receiver is connected
- Consult the dealer or an experienced radio/TV technician for help.

### 9.1 FCC Label



#### CONFIDENTIAL AND PROPRIETARY

The Information contained in this document shall remain the sole exclusive property of s.m.s smart microwave sensors GmbH and shall not be disclosed by the recipient to third parties without prior consent of s.m.s smart microwave sensors GmbH in writing.

## **10 Declaration of Conformity for CANADA**

*This device complies with Industry Canada licence-exempt RSS standard(s). Operation is subject to the following two conditions: (1) this device may not cause interference, and (2) this device must accept any interference, including interference that may cause undesired operation of the device.*

*Le présent appareil est conforme aux CNR d'Industrie Canada applicables aux appareils radio exempts de licence. L'exploitation est autorisée aux deux conditions suivantes : (1) l'appareil ne doit pas produire de brouillage, et (2) l'utilisateur de l'appareil doit accepter tout brouillage radioélectrique subi, même si le brouillage est susceptible d'en compromettre le fonctionnement.*

### **CONFIDENTIAL AND PROPRIETARY**

The Information contained in this document shall remain the sole exclusive property of s.m.s smart microwave sensors GmbH and shall not be disclosed by the recipient to third parties without prior consent of s.m.s smart microwave sensors GmbH in writing.