



Test report No. : 10003907H-B-R2
Page : 1 of 65
FCC ID : W2Z-02100002
Issued date : March 19, 2013
Revised date : March 28, 2013

SAR TEST REPORT

Test Report No. : 10003907H-B-R2

Applicant : FUJIFILM Corporation
Type of Equipment : Wireless LAN Module
Model No. : DWMW092
FCC ID : W2Z-02100002
Test regulation : FCC47CFR 2.1093
FCC OET Bulletin 65, Supplement C (Edition 01-01)
Test Result : Complied
FCC Part15.247 Body : 0.279W/kg

1. This test report shall not be reproduced in full or partial, without the written approval of UL Japan, Inc.
2. The results in this report apply only to the sample tested.
3. This sample tested is in compliance with the limits of the above regulation.
4. The test results in this report are traceable to the national or international standards.
5. This test report must not be used by the customer to claim product certification, approval, or endorsement by NVLAP, NIST, or any agency of the Federal Government.
6. This report is a revised version of 10003907H-B-R1. 10003907H-B-R1 is replaced with this report.

Date of test: March 01, 2013

Representative
test engineer:

Satofumi Matsuyama
Engineer of WiSE Japan,
UL Verification Service

Approved by :

Takahiro Hatakeda
Reader of WiSE Japan
UL Verification Service



NVLAP LAB CODE: 200572-0

This laboratory is accredited by the NVLAP LAB CODE 200572-0, U.S.A. The tests reported herein have been performed in accordance with its terms of accreditation. *As for the range of Accreditation in NVLAP, you may refer to the WEB address, <http://www.ul.com/japan/jpn/pages/services/emc/about/mark1/index.jsp#nvlap>

UL Japan, Inc.

Head Office EMC Lab.

4383-326 Asama-cho, Ise-shi, Mie-ken 516-0021 JAPAN

Telephone: +81 596 24 8116

Facsimile: +81 596 24 8124

13-EM-F0429

CONTENTS	PAGE
SECTION 1: Customer information	4
SECTION 2: Equipment under test (E.U.T.).....	4
2.1 Identification of E.U.T.	4
2.2 Product Description.....	4
SECTION 3 : Test standard information.....	5
3.1 Test Specification	5
3.2 Procedure	5
3.3 Exposure limit	6
3.4 Test Location.....	6
SECTION 4 : Test result	7
4.1 Stand-alone SAR result	7
SECTION 5 : Description of the operating mode.....	8
5.1 Output power operating modes	8
5.2 Output power measurement results	9
5.3 SAR testing operating modes	11
5.4 Confirmation after SAR testing	13
SECTION 6 SAR test exclusion considerations.....	14
6.1 Standalone SAR test exclusion considerations.....	14
SECTION 7 : Description of the Body setup	15
7.1 Test position for Body setup	15
SECTION 8 : Test surrounding.....	17
8.1 Measurement uncertainty	17
SECTION 9 : Measurement results.....	18
9.1 WLAN Body SAR.....	18
SECTION 10 Test instruments	19
APPENDIX 1 : SAR Measurement data.....	21
1. Evaluation procedure.....	21
2. Measurement data.....	22
APPENDIX 2 : System Validation	29
1. System validation result for 2450MHz.....	29
2. System Validation Dipole (D2450V2,S/N:713)	31
3. Validation uncertainty	42
APPENDIX 3 : System specifications.....	43
1. Configuration and peripherals	43
2. Specifications	44
3. Dosimetric E-Field Probe Calibration (EX3DV4, S/N: 3825)	48
APPENDIX 4: Photographs of test setup.....	59
1. Photographs of EUT.....	59
2. Antenna position	60
3. Photographs of setup	61

SECTION 1: Customer information

Company Name : FUJIFILM Corporation
 Address : 1-324 UETAKE, KITA-KU, SAITAMA-SHI SAITAMA, 331-9624,
 JAPAN
 Telephone Number : +81-48-668-5140
 Facsimile Number : +81-48-668-7093
 Contact Person : Masakatsu Kubota

SECTION 2: Equipment under test (E.U.T.)**2.1 Identification of E.U.T.****<Information of the EUT>**

Type of Equipment : Wireless LAN module
 Model No. : DWMW092
 Serial No. : None
 Rating : DC 3.3V
 Country of Mass-production : Philippines
 Condition of EUT : Production prototype
 (Not for Sale: This sample is equivalent to mass-produced items.)
 Modification of EUT : No Modification by the test lab

<Information of the Host device>

Type of Equipment : Digital Camera
 Model No. : FinePix XP200
 Serial No. : 1119
 Size : H: 71.2mm W: 117.7mm D: 31.0mm
 Rating : Li-ion Battery (M/N;NP-50)
 DC3.6V 1000mAh 3.4Wh
 Option Battery : N/A
 Device category : Portable
 Receipt Date of Sample : March 01, 2013
 Country of Mass-production : Indonesia

2.2 Product Description**General Specification****<EUT>**

Clock frequency(ies) in the system : 26MHz

<Host device>

Clock frequency(ies) in the system : 48MHz, 32.768kHz for main system
 26MHz for Wireless LAN

Radio Specification of WLAN (IEEE802.11b/g/n)

Radio Type : Transceiver
 Frequency of Operation : 2412-2462MHz
 Modulation : DSSS and OFDM
 Power Supply (radio part input) : DC3.3V (Digital part), DC1.6V (RF Core), DC1.2V (Digital part)
 Antenna type : 2.4GHz Pattern Antenna
 Antenna Gain : 0.41dBi

UL Japan, Inc.**Head Office EMC Lab.**

4383-326 Asama-cho, Ise-shi, Mie-ken 516-0021 JAPAN

Telephone: +81 596 24 8116

Facsimile: +81 596 24 8124

SECTION 3 : Test standard information

3.1 Test Specification

Title : **Supplement C (Edition 01-01) to OET Bulletin 65 (Edition 97-01):**

Supplement C (Edition 01-01) - Additional Information for Evaluating Compliance of Mobile and Portable Devices with FCC Limits for Human Exposure to Radiofrequency Emissions
OET Bulletin 65 (Edition 97-01) - Evaluating Compliance with FCC Guidelines for Human Exposure to Radiofrequency Electromagnetic Fields

: **IEEE Std 1528-2003:**

IEEE Recommended Practice for Determining the Peak Spatial-Average Specific Absorption Rate (SAR) in the Human Head from Wireless Communications Devices: Measurement Techniques Supplement C

In additions;

- KDB450824D01(v01r01)** SAR Prob Cal and Ver Meas
- KDB450824D02(v01r01)** Dipole SAR Validation Verification
- KDB447498D01(v05)** Mobile and Portable Device RF Exposure Procedures and Equipment Authorization Policies
- KDB447498D02(v02)** SAR Measurement Procedures for USB Dongle Transmitters
- KDB648474D04(v01)** SAR Evaluation Considerations for Wireless Handsets
- KDB941225D01(v02)** SAR Measurement Procedures for 3G Devices
- KDB941225D02(v02v01)** 3GPP R6 HSPA and R7 HSPA+ SAR Guidance
- KDB941225D03(v01)** Recommended SAR Test Reduction Procedures for GSM/GPRS/EDGE
- KDB941225D04(v01)** Evaluating SAR for GSM/(E)GPRS Dual Transfer Mode
- KDB941225D05(v02)** SAR for LTE Devices
- KDB941225D06(v01)** SAR test procedures for devices incorporating SAR Evaluation Procedures for Portable Devices with Wireless Router Capabilities (Hot Spot SAR)
- KDB941225D07(v01)** SAR Evaluation Procedures for UMPC Mini-Tablet Devices
- KDB 616217D04(v01)** SAR Evaluation Considerations for Laptop, Notebook, Netbook and Tablet Computers
- KDB865664D01(v01)** SAR Measurement Requirements for 100MHz to 6 GHz
- KDB248227D01(v01r02)** SAR Measurement Procedures for 802.11a/b/g Transmitters

Reference

- [1]ANSI, ANSI/IEEE C95.1-1992: IEEE Standard for Safety Levels with Respect to Human Exposure to Radio Frequency Electromagnetic Fields, 3 kHz to 300 GHz, The Institute of Electrical and Electronics Engineers, Inc., New York, NY 10017, 1992.
[2]SPEAG uncertainty document (AN 15-7/AN19-17) for DASY 5 System from SPEAG (Shimid & Partner Engineering AG).

3.2 Procedure

Transmitter	WLAN
Test Procedure	FCC OET BULLETIN 65, SUPPLEMENT C SAR
Category	FCC47CFR 2.1093
Note: UL Japan, Inc. 's SAR Work Procedures 13-EM-W0429 and 13-EM-W0430	

UL Japan, Inc.

Head Office EMC Lab.

4383-326 Asama-cho, Ise-shi, Mie-ken 516-0021 JAPAN

Telephone: +81 596 24 8116

Facsimile: +81 596 24 8124

3.3 Exposure limit

(A) Limits for Occupational/Controlled Exposure (W/kg)

Spatial Average (averaged over the whole body)	Spatial Peak (averaged over any 1g of tissue)	Spatial Peak (hands/wrists/feet/ankles averaged over 10g)
0.4	8.0	20.0

(B) Limits for General population/Uncontrolled Exposure (W/kg)

Spatial Average (averaged over the whole body)	Spatial Peak (averaged over any 1g of tissue)	Spatial Peak (hands/wrists/feet/ankles averaged over 10g)
0.08	1.6	4.0

Occupational/Controlled Environments: are defined as locations where there is exposure that may be incurred by people who are aware of the potential for exposure, (i.e. as a result of employment or occupation).

General Population/Uncontrolled Environments: are defined as locations where there is the exposure of individuals who have no knowledge or control of their exposure.

NOTE:GENERAL POPULATION/UNCONTROLLED EXPOSURE SPATIAL PEAK(averaged over any 1g of tissue) LIMIT 1.6 W/kg
--

3.4 Test Location

*Shielded room for SAR testings

UL Japan, Inc. Head Office EMC Lab. *NVLAP Lab. code: 200572-0

4383-326 Asama-cho, Ise-shi, Mie-ken 516-0021 JAPAN

Telephone : +81 596 24 8116

Facsimile : +81 596 24 8124

UL Japan, Inc.

Head Office EMC Lab.

4383-326 Asama-cho, Ise-shi, Mie-ken 516-0021 JAPAN

Telephone: +81 596 24 8116

Facsimile: +81 596 24 8124

SECTION 4 : Test result

4.1 Stand-alone SAR result

Measured SAR

Mode	1g SAR [W/kg]
WLAN 11b/g/n(2.4G)	0.279

Scaled SAR*1

Mode	1g SAR [W/kg]
WLAN 11b/g/n(2.4G)	0.279

*1 Measured maximum output power is a maximum of specification. Therefore, compensation calculation was not done.

SECTION 5 : Description of the operating mode

5.1 Output power operating modes

Mode	Duty cycle	Frequency Band	Test Frequency	Modulation
IEEE802.11b	100%	2412-2462MHz	2412MHz (1ch) 2437MHz(6ch) 2462MHz(11ch)	DSSS (DBPSK.DQPSK.CCK)
IEEE802.11g	100%	2412-2462MHz	2412MHz (1ch) 2437MHz(6ch) 2462MHz(11ch)	OFDM (BPSK.QPSK.16QAM,64QAM) Long GI, Short GI
IEEE802.11n20 (2.4G)	100%	2412-2462MHz	2412MHz (1ch) 2437MHz(6ch) 2462MHz(11ch)	

WLAN

*Power of the EUT was set by the software as follows;

Power settings: 11b/g: 14.5, 11n: 12.5

Software: Wi-Fi_GUI_TOOL (Release X86) Version: 1.0.0.0

*This setting of software is the worst case.

Any conditions under the normal use do not exceed the condition of setting.

In addition, end users cannot change the settings of the output power of the product.

5.2 Output power measurement results

Output power measurement for WLAN

1) WLAN (11b/g/n(2.4G))

Note:

1.The 11b mode was maximum average power. The 11g/n SAR is not required for other mode because the maximum average output power for other mode is less than 1/4dB higher than that measured 11b mode.

2.The other channels are measured if the SAR result at max. AVG power channel will be above 0.8W/kg

IEEE802.11b

Frequency [MHz]	Rate [Mbps]	P/M Reading [dBm]		Cable Loss [dB]	Atten. [dB]	Result			
		[dBm]				[mW]			
		PK	AVG			PK	AVG		
2412	2	3.66	0.32	0.53	10.07	14.26	10.92	26.67	12.36
2437	2	3.78	0.43	0.53	10.07	14.38	11.03	27.42	12.68
2462	2	3.89	0.54	0.53	10.07	14.49	11.14	28.12	13.00
2462	1	3.84	0.52	0.53	10.07	14.44	11.12	27.80	12.94

IEEE802.11g

Frequency [MHz]	Rate [Mbps]	P/M Reading [dBm]		Cable Loss [dB]	Atten. [dB]	Result			
		[dBm]				[mW]			
		PK	AVG			PK	AVG		
2412	36	8.76	-0.50	0.53	10.07	19.36	10.10	86.30	10.23
2437	36	8.53	-1.24	0.53	10.07	19.13	9.36	81.85	8.63
2462	36	8.48	-0.94	0.53	10.07	19.08	9.66	80.91	9.25

IEEE802.11n-20 Short GI

Frequency [MHz]	MCS	P/M Reading [dBm]		Cable Loss [dB]	Atten. [dB]	Result			
		[dBm]				[mW]			
		PK	AVG			PK	AVG		
2412	6	7.39	-2.41	0.53	10.07	17.99	8.19	62.95	6.59
2437	6	6.93	-3.13	0.53	10.07	17.53	7.47	56.62	5.58
2462	6	7.06	-2.82	0.53	10.07	17.66	7.78	58.34	6.00

Sample Calculation:

Result = Reading + Cable Loss + Attenuator

* Power Correlation

<RF Test>

IEEE 802.11b 12.65mW * maximum average power.

* The above conducted power was calculated by the below formula:

$$11.43[\text{dBm}] (\text{eirp measured in RF testing}) - 0.41[\text{dBi}] (\text{antenna gain}) = 11.02[\text{dBm}] \rightarrow 12.65 [\text{mW}]$$

<SAR Test>

IEEE 802.11b 13.00mW * maximum average power.

Average Power used for SAR testing can be regarded to be correlated with the one in RF testing as the difference between the two powers is within 0 to 5 %.

UL Japan, Inc.

Head Office EMC Lab.

4383-326 Asama-cho, Ise-shi, Mie-ken 516-0021 JAPAN

Telephone: +81 596 24 8116

Facsimile: +81 596 24 8124

[IEEE802.11b] Rate Check

Rate [Mbps]	Freq. [MHz]	Reading [dBm]	Remark
1	2437	0.40	
2	2437	0.43	*
5.5	2437	0.22	
11	2437	0.23	

*: Worst Rate

[IEEE802.11g] Rate Check

Rate [Mbps]	Freq. [MHz]	Reading [dBm]	Remark
6	2437	-1.42	
9	2437	-1.41	
12	2437	-1.35	
18	2437	-1.35	
24	2437	-1.27	
36	2437	-1.24	*
48	2437	-1.33	
54	2437	-1.31	

*: Worst Rate

[IEEE802.11n] Rate Check

Rate	Freq. [MHz]	Reading Short GI [dBm]	Reading Long GI [dBm]	Remark
MCS0	2437	-3.32		
MCS1	2437	-3.28		
MCS2	2437	-3.26		
MCS3	2437	-3.21		
MCS4	2437	-3.17		
MCS5	2437	-3.17		
MCS6	2437	-3.13*	-3.48	
MCS7	2437	-3.18		

*: Worst Rate

UL Japan, Inc.**Head Office EMC Lab.**

4383-326 Asama-cho, Ise-shi, Mie-ken 516-0021 JAPAN

Telephone: +81 596 24 8116

Facsimile: +81 596 24 8124

5.3 SAR testing operating modes

The operating mode for SAR testing was decided by the output power

SAR measurement for WLAN

Mode	Crest factor	Modulation	Test Frequency	Note
IEEE802.11b	1	DBPSK(1Mbps) DQPSK(2Mbps)	2462MHz(11ch)	*2 *3 1)
IEEE802.11g	Not required			*1
IEEE802.11n20 (2.4G)	Not required			*1

WLAN

*Power of the EUT was set by the software as follows;

Power settings: 11b/g: 11, 11n: 9

Software: Wi-Fi_GUI_TOOL (Release X86) Version: 1.0.0.0

*This setting of software is the worst case.

Any conditions under the normal use do not exceed the condition of setting.

In addition, end users cannot change the settings of the output power of the product.

Decision of SAR test channel

The operating mode for SAR testing was decided by the output power

Mode	GHz	Channel	Turbo Channel	"Default Test Channel"	
				FCC 15.247	
				802.11b	802.11g
802.11 b/g/n20	2.412	1		√	Δ
	2.437	6	6	√	Δ
	2.462	11		√	Δ

√ = "default test channels"

Δ = Possible 802.11g channels with maximum average output $\frac{1}{4}$ dB \geq the "default test channels"

*1 The 11b mode was maximum average power. The 11g/n SAR is not required for other mode because the maximum average output power for other mode is less than 1/4dB higher than that measured 11b mode.

*2 The other channel was not required since maximum average output power channel SAR value is less than 0.8W/kg.

*3

1) Repeated measurement is not required when the original highest measured SAR is < 0.80 W/kg

5.4 Confirmation after SAR testing

It was checked that the power drift [W] is within +/-5%.The verification of power drift during the SAR test is that DASY5 system calculates the power drift by measuring the e-field at the same location at beginning and the end of the scan measurement for each test position.

DASY5 system calculation Power drift value[dB] = $20\log(E_a)/(E_b)$

Before SAR testing : E_b [V/m]

After SAR testing : E_a [V/m]

Limit of power drift[W] = +/-5%

$X[\text{dB}] = 10\log[P] = 10\log(1.05/1) = 10\log(1.05) - 10\log(1) = 0.212\text{dB}$

from E-field relations with power.

$p = E^2/\eta = E^2/$

Therefore, The correlation of power and the E-field

$X_{\text{dB}} = 10\log(P) = 10\log(E)^2 = 20\log(E)$

Therefore,

The calculated power drift of DASY5 System must be the less than +/-0.212dB.

SECTION 6 SAR test exclusion considerations

6.1 Standalone SAR test exclusion considerations

The 1-g and 10-g SAR test exclusion thresholds for 100 MHz to 6 GHz at test separation distances ≤ 50 mm are determined by:

$[(\text{max. power of channel, including tune-up tolerance, mW})/(\text{min. test separation distance, mm})] \cdot [\sqrt{f(\text{GHz})}] \leq 3.0$ for 1-g SAR and ≤ 7.5 for 10-g extremity SAR, where

- $f(\text{GHz})$ is the RF channel transmit frequency in GHz
- Power and distance are rounded to the nearest mW and mm before calculation
- The result is rounded to one decimal place for comparison

The test exclusions are applicable only when the minimum test separation distance is ≤ 50 mm and for transmission frequencies between 100 MHz and 6 GHz. When the minimum test separation distance is < 5 mm, a distance of 5 mm is applied to determine SAR test exclusion.

Mode	Modulation	Test Frequency	Max power (Meas)	Scaled power	Min. distance *2	Calculation of exclusion	Standalone SAR tested
IEEE802.11b	DQPSK(2Mbps)	2462MHz(11ch)	11.14 dBm/ 13.00mW	*1	<5mm	4.08	<input checked="" type="checkbox"/>

*1 The EUT of maximum output power was used. Therefore, compensation calculation was not done.

*2 Refer to SECTION 7

SECTION 7 : Description of the Body setup

7.1 Test position for Body setup

i) Procedure for SAR testing

The tested procedure was performed according to the KDB 447498 D01 (Mobile and Portable Device RF Exposure Procedures and Equipment Authorization Policies)

ii) Test mode

WLAN	Data transmission mode (11b)
------	------------------------------

iii) Test position

No.	Position*	Test distance	WLAN		
			Tested	Antenna	Separation from user
1	Top	0mm	<input checked="" type="checkbox"/>	Fixed	< 25mm
2	Front	0mm	<input checked="" type="checkbox"/>	Fixed	< 25mm
3	Rear	0mm	<input checked="" type="checkbox"/>	Fixed	< 25mm
4	Bottom	0mm	<input checked="" type="checkbox"/> *1)	Fixed	> 25mm
5	Right Side	0mm	<input type="checkbox"/>	Fixed	> 25mm
6	Left Side	0mm	<input checked="" type="checkbox"/>	Fixed	< 25mm

*1) Reference data

UL Japan, Inc.

Head Office EMC Lab.

4383-326 Asama-cho, Ise-shi, Mie-ken 516-0021 JAPAN

Telephone: +81 596 24 8116

Facsimile: +81 596 24 8124

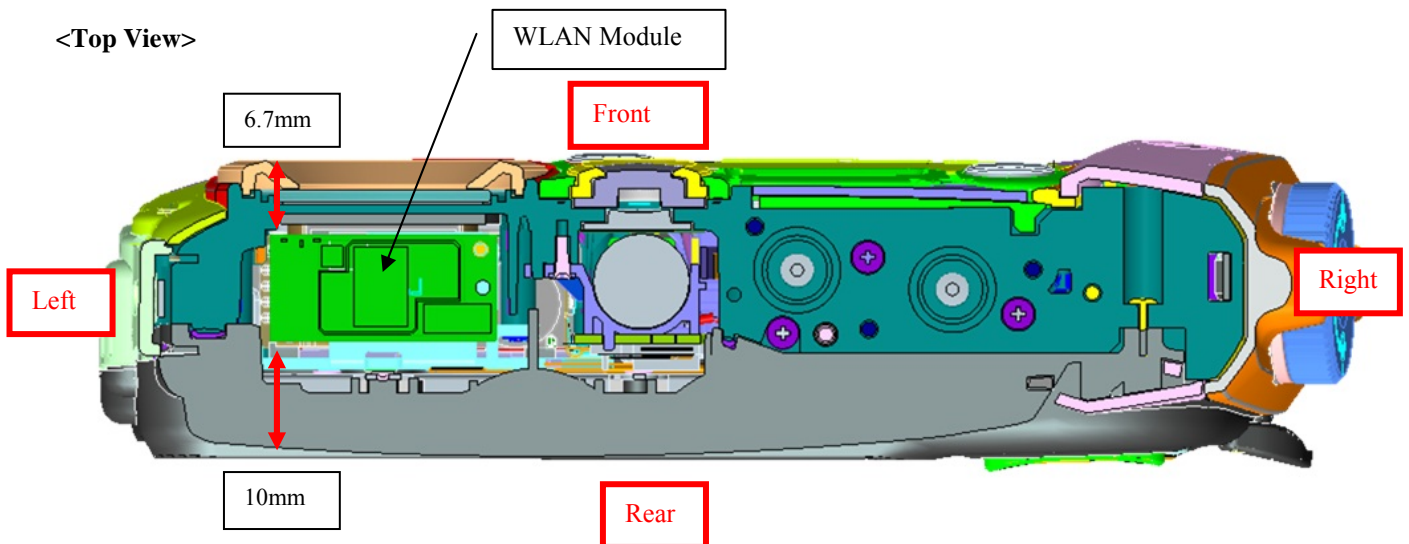
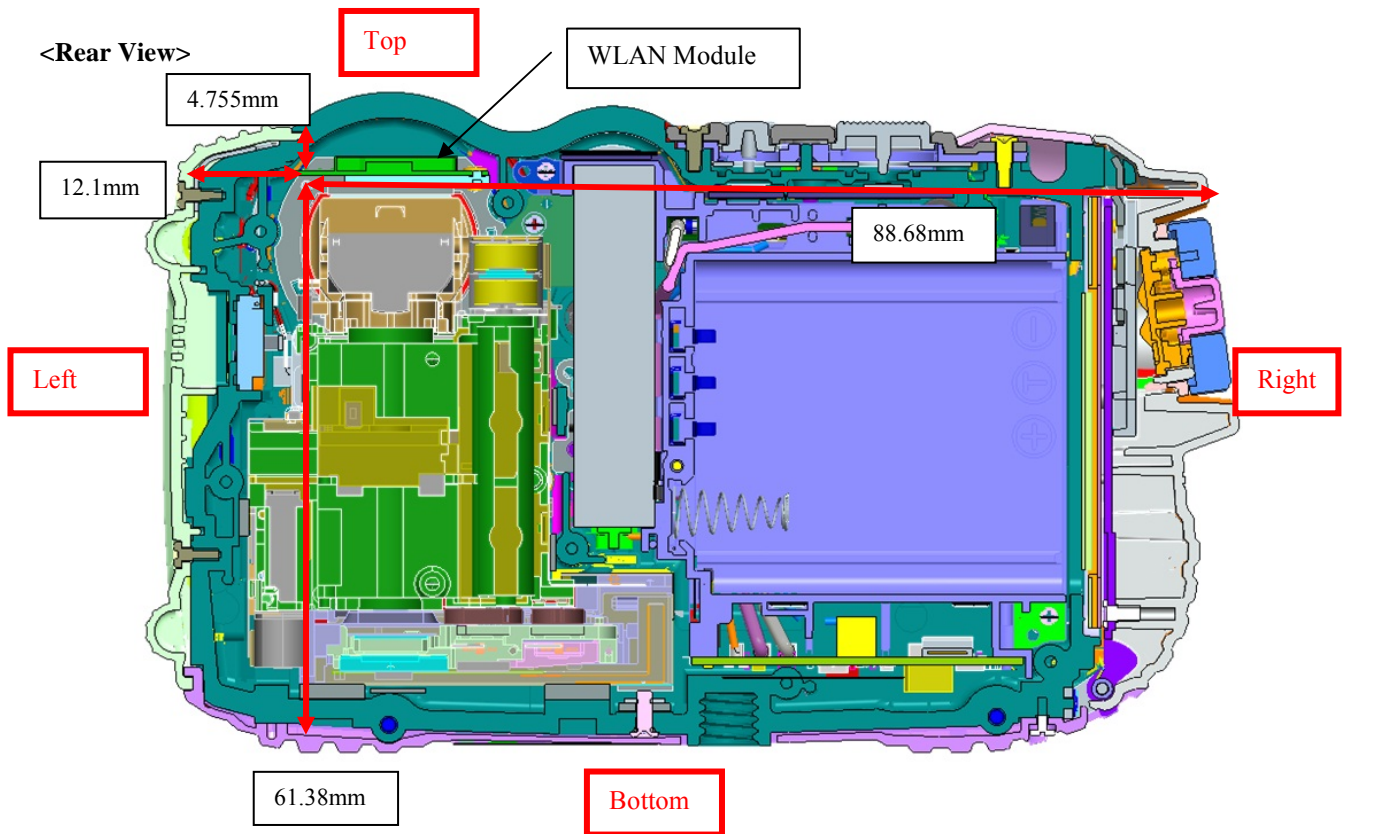

<Antenna position>

The antennas use for WLAN fixed position.
The antennas are integral part of the device

UL Japan, Inc.

Head Office EMC Lab.

4383-326 Asama-cho, Ise-shi, Mie-ken 516-0021 JAPAN

Telephone: +81 596 24 8116

Facsimile: +81 596 24 8124

SECTION 8 : Test surrounding

8.1 Measurement uncertainty

The uncertainty budget has been determined for the DASY5 measurement system according to the SPEAG documents[2] and is given in the following Table.

<0.3 – 3GHz range>

Error Description	Uncertain value \pm	Probability distribution	divisor	(ci) lg	Standard (lg)	vi or veff
Measurement System						
Probe calibration	\pm 6.55	Normal	1	1	\pm 6.55	∞
Axial isotropy of the probe	\pm 4.7	Rectangular	$\sqrt{3}$	1	\pm 2.7	∞
Spherical isotropy of the probe	\pm 9.6	Rectangular	$\sqrt{3}$	0	\pm 0.0	∞
Boundary effects	\pm 1.0	Rectangular	$\sqrt{3}$	1	\pm 0.6	∞
Probe linearity	\pm 4.7	Rectangular	$\sqrt{3}$	1	\pm 2.7	∞
Detection limit	\pm 1.0	Rectangular	$\sqrt{3}$	1	\pm 0.6	∞
Modulation response	\pm 0.0	Rectangular	$\sqrt{3}$	1	\pm 0.0	∞
Readout electronics	\pm 0.3	Normal	1	1	\pm 0.3	∞
Response time	\pm 0.0	Rectangular	$\sqrt{3}$	1	\pm 0.0	∞
Integration time	\pm 0.0	Rectangular	$\sqrt{3}$	1	\pm 0.0	∞
RF ambient Noise	\pm 1.0	Rectangular	$\sqrt{3}$	1	\pm 0.6	∞
RF ambient Reflections	\pm 1.0	Rectangular	$\sqrt{3}$	1	\pm 0.6	∞
Probe Positioner	\pm 0.8	Rectangular	$\sqrt{3}$	1	\pm 0.5	∞
Probe positioning	\pm 6.7	Rectangular	$\sqrt{3}$	1	\pm 3.9	∞
Max.SAR Eval.	\pm 2.0	Rectangular	$\sqrt{3}$	1	\pm 1.2	∞
Dipole Related						
Deviation of exp.dipole	\pm 5.5	Rectangular	$\sqrt{3}$	1	\pm 3.2	5
Dipole Axis to Liquid Distance	\pm 2.0	Rectangular	$\sqrt{3}$	1	\pm 1.2	4
Input power and SAR drift meas.	\pm 3.4	Rectangular	$\sqrt{3}$	1	\pm 2.0	∞
Phantom and Setup						
Phantom uncertainty	\pm 4.0	Rectangular	$\sqrt{3}$	1	\pm 2.3	∞
Liquid conductivity (target)	\pm 5.0	Rectangular	$\sqrt{3}$	0.78	\pm 2.3	∞
Liquid conductivity (meas.)	+ 5.0	Normal	1	0.26	+ 1.3	∞
Liquid permittivity (target)	\pm 5.0	Rectangular	$\sqrt{3}$	0.78	\pm 2.3	∞
Liquid permittivity (meas.)	- 5.0	Normal	1	0.23	- 1.2	∞
Liquid conductivity - temp.unc (below 2deg.C.)	\pm 1.7	Rectangular	$\sqrt{3}$	0.78	\pm 0.8	∞
Liquid permittivity - temp.unc (below 2deg.C.)	\pm 0.3	Rectangular	$\sqrt{3}$	0.23	\pm 0.0	∞
Combined Standard Uncertainty					\pm 10.491	
Expanded Uncertainty (k=2)					\pm 21.0	

UL Japan, Inc.

Head Office EMC Lab.

4383-326 Asama-cho, Ise-shi, Mie-ken 516-0021 JAPAN

Telephone: +81 596 24 8116

Facsimile: +81 596 24 8124

SECTION 9 : Measurement results**9.1 WLAN Body SAR****(1)Method of measurement**

Step1. The searching for the worst modulation

The test was performed in minimum rate and maximum average output power mode.

Step2. The searching for the worst position

The test was performed at the worst condition of Step1.

Note:

1) The BODY SAR is not required for 11g/n mode because the maximum average output power for 11g/n mode is less than 1/4dB higher than that measured 11b mode.

2) The other channel was not required since maximum average output power channel SAR value is less than 0.8W/kg.

(2)Simulated Tissue Liquid Parameter confirmation

The dielectric parameters were checked prior to assessment using the HP85070D dielectric probe kit.

The dielectric parameters measurement is reported in each correspondent section.

DIELECTRIC PARAMETERS MEASUREMENT RESULTS										
Date	Ambient Temp. [deg.c]	Relative Humidity [%]	Liquid type	Liquid Temp. [deg.c]	Measured Frequency [MHz]	Parameters	Target Value*1	Measured	Deviation [%]	Limit [%]
1-Mar	24.0	42	MSL 2450	23.5	2462	ϵ_r	52.7	50.4	-4.3	+/-5
						σ [mho/m]	1.95	2.00	2.6	+/-5

ϵ_r : Relative Permittivity / σ : Conductivity

*1 The Target value is a parameter defined in FCC OET65.

(3)Result of Body SAR

BODY SAR MEASUREMENT RESULTS							
Frequency		Modulation	Phantom Section	EUT Set-up Conditions			SAR(1g) [W/kg]
Channel	[MHz]			Antenna	Position	Separation [mm]	Maximum value of multi-peak
Step.1 Modulation searching							
11	2462	11b 1Mbps	Flat	Fixed	Bottom	0	0.012
11	2462	11b 2Mbps	Flat	Fixed	Bottom	0	0.017
Step.2 Position searching							
11	2462	11b 2Mbps	Flat	Fixed	Top	0	0.125
11	2462	11b 2Mbps	Flat	Fixed	Front	0	0.279
11	2462	11b 2Mbps	Flat	Fixed	Rear	0	0.057
11	2462	11b 2Mbps	Flat	Fixed	Left Side	0	0.040

UL Japan, Inc.

Head Office EMC Lab.

4383-326 Asama-cho, Ise-shi, Mie-ken 516-0021 JAPAN

Telephone: +81 596 24 8116

Facsimile: +81 596 24 8124

SECTION 10 Test instruments

Control No.	Instrument	Manufacturer	Model No	Serial No	Test Item	Calibration Date	Expiration date of the calibration
MOS-04	Digital Humidity Indicator	N.T	NT-1800	MOS04	Power	2013/02/26	2014/02/28
MAT-24	Attenuator(10dB)(above 1GHz)	Agilent	8493C	71389	Power	2012/06/27	2013/06/30
MPM-09	Power Meter	Anritsu	ML2495A	6K00003348	Power	2012/10/08	2013/10/31
MPSE-12	Power sensor	Anritsu	MA2411B	011598	Power	2012/10/08	2013/10/31

UL Japan, Inc.**Head Office EMC Lab.**

4383-326 Asama-cho, Ise-shi, Mie-ken 516-0021 JAPAN

Telephone: +81 596 24 8116

Facsimile: +81 596 24 8124

Control No.	Instrument	Manufacturer	Model No	Serial No	Test Item	Calibration Date	Expiration date of the calibration
MPM-01	Power Meter	Agilent	E4417A	GB41290639	SAR	2012/03/05	2013/03/31
MPSE-01	Power Sensor	Agilent	E9300B	US40010300	SAR	2013/03/01	2014/03/31
MPSE-03	Power sensor	Agilent	E9327A	US40440576	SAR	2012/03/07	2013/03/31
MAT-15	Attenuator(30dB)	Agilent	8498A	US40010300	SAR	2012/03/15	2013/03/31
MSG-10	Signal Generator	Agilent	N5181A	MY47421098	SAR	2012/10/08	2013/10/31
MPA-12	MicroWave System Amplifier	Agilent	83017A	MY39500780	SAR	2012/03/28	2013/03/31
MRFA-08	Pre Amplifier	TSJ	TCBP0206	-	SAR	2012/03/22	2013/03/31
MHDC-12	Dual Directional Coupler	Hewlett Packard	772D	2839A0016	SAR	Pre Check	-
MNA-01	Network Analyzer	Agilent/HP	E8358A	US41080381	SAR	2012/09/14	2013/09/30
MDPK-01	Dielectric probe kit	Agilent	85070D	702	SAR	2012/08/14	2013/08/31
MNCK-01	Type N Calibration Kit	Agilent	85032F	MY41495257	SAR	2012/09/18	2013/09/30
MPB-07	Dosimetric E-Field Probe	Schmid&Partner Engineering AG	EX3DV4	3825	SAR	2012/12/10	2013/12/31
MDAE-01	Data Acquisition Electronics	Schmid&Partner Engineering AG	DAE4	509	SAR	2012/07/13	2013/07/31
COTS-MSAR-03	Dasy5	Schmid&Partner Engineering AG	DASY52.6.1.408	-	SAR	-	-
COTS-MSAR-02	S-Parameter Network Analyzer	Agilent	-	-	SAR	-	-
MDA-07	Dipole Antenna	Schmid&Partner Engineering AG	D2450V2	713	SAR	2012/09/21	2013/09/30
MPSAM-02	SAM Phantom	Schmid&Partner Engineering AG	SAM Twin Phantom V4.0	1333	SAR	2012/05/07	2013/05/31
MPF-02	2mmOval Flat Phantom ERI 4.0	Schmid&Partner Engineering AG	QD VA 001B (ERI4.0)	1045	SAR	2012/05/08	2013/05/31
MDH-01	Device holder	Schmid&Partner Engineering AG	Mounting device for transmitter	-	SAR	Pre Check	-
MOS-26	Thermo-Hygrometer	CUSTOM	CTH-201	A08Q29	SAR	2012/05/14	2013/05/31
MOS-10	Digital thermometer	HANNA	Checktemp-2	MOS-10	SAR	2012/08/06	2013/08/31
MBM-13	Barometer	Sunoh	SBR121	837	SAR	2011/03/14	2014/03/31
MSL2450					Daily check	Target value \pm 5%	
SAR room					Daily check	Ambient Noise < 0.012W/kg	

The expiration date of the calibration is the end of the expired month.

All equipment is calibrated with valid calibrations. Each measurement data is traceable to the national or international standards.

As for some calibrations performed after the tested dates, those test equipment have been controlled by means of an unbroken chains of calibrations.

UL Japan, Inc.

Head Office EMC Lab.

4383-326 Asama-cho, Ise-shi, Mie-ken 516-0021 JAPAN

Telephone: +81 596 24 8116

Facsimile: +81 596 24 8124

APPENDIX 1 : SAR Measurement data

1. Evaluation procedure

The evaluation was performed with the following procedure:

Step 1: Measurement of the E-field at a fixed location above the ear point or central position of flat phantom was used as a reference value for assessing the power drop.

Step 2: The SAR distribution at the exposed side of head or body position was measured at a distance of each device from the inner surface of the shell. The area covered the entire dimension of the antenna of EUT and the horizontal grid spacing was 15 mm x 15 mm, 12 mm x 12 mm or 10mm x 10mm. Based on these data, the area of the maximum absorption was determined by spline interpolation.

Step 3: Around this point found in the Step 2 (area scan) , a volume of 30mm x 30mm x 30mm or more was assessed by measuring 7 x 7 x 7 points at least. And for any secondary peaks found in the Step2 which are within 2dB of maximum peak and not with this Step3 (Zoom scan) is repeated. On the basis of this data set, the spatial peak SAR value was evaluated under the following procedure:

(1). The data at the surface were extrapolated, since the center of the dipoles is 1mm(EX3DV3) away from the tip of the probe and the distance between the surface and the lowest measuring point is 1.3 mm. The extrapolation was based on a least square algorithm [4]. A polynomial of the fourth order was calculated through the points in z-axes.

This polynomial was then used to evaluate the points between the surface and the probe tip.

(2). The maximum interpolated value was searched with a straightforward algorithm. Around this maximum the SAR values averaged over the spatial volumes (1 g or 10 g) were computed by the 3D-Spline interpolation algorithm. The 3D-Spline is composed of three one-dimensional splines with the "Not a knot"-condition (in x, y and z-directions) [4], [5]. The volume was integrated with the trapezoidal-algorithm. One thousand points (10 x 10 x 10) were interpolated to calculate the average.

(3). All neighboring volumes were evaluated until no neighboring volume with a higher average value was found.

Step 4: Re-measurement of the E-field at the same location as in Step 1.

2. Measurement data

【WLAN Body】

SG7A2 WLAN 11b 1Mbps Bottom 0mm 2462MHz

Communication System: WLAN 11a/b/g/n ; Communication System Band: WLAN 11b/g/n; Frequency: 2462 MHz; Duty Cycle: 1:1

Medium parameters used (interpolated): $f = 2462$ MHz; $\sigma = 2$ mho/m; $\epsilon_r = 50.444$; $\rho = 1000$ kg/m³

Phantom section: Flat Section

Measurement Standard: DASYS (IEEE/IEC/ANSI C63.19-2007)

DASY5 Configuration

Probe: EX3DV4 - SN3825; ConvF(7.33, 7.33, 7.33); Calibrated: 2012/12/10; {Probe: Calibration Date}

Sensor-Surface: 2mm (Mechanical Surface Detection)

Electronics: DAE4 Sn509; Calibrated: 2012/07/13

Phantom: ELI 4.0; Type: QDOVA001BA; Serial: xxxx

Measurement SW: DASYS2, Version 52.8 (3);

Area Scan (71x81x1): Interpolated grid: dx=1.200 mm, dy=1.200 mm

Maximum value of SAR (interpolated) = 0.0204 W/kg

Zoom Scan (7x7x7)/Cube 0: Measurement grid: dx=5mm, dy=5mm, dz=5mm

Reference Value = 1.992 V/m; Power Drift = 0.11 dB

Peak SAR (extrapolated) = 0.0270 W/kg

SAR(1 g) = 0.012 W/kg; SAR(10 g) = 0.00471 W/kg

Maximum value of SAR (measured) = 0.0187 W/kg

Date: 2013/03/01

Ambient Temp. : 24.0 degree.C. Liquid Temp.; 23.5 degree.C.

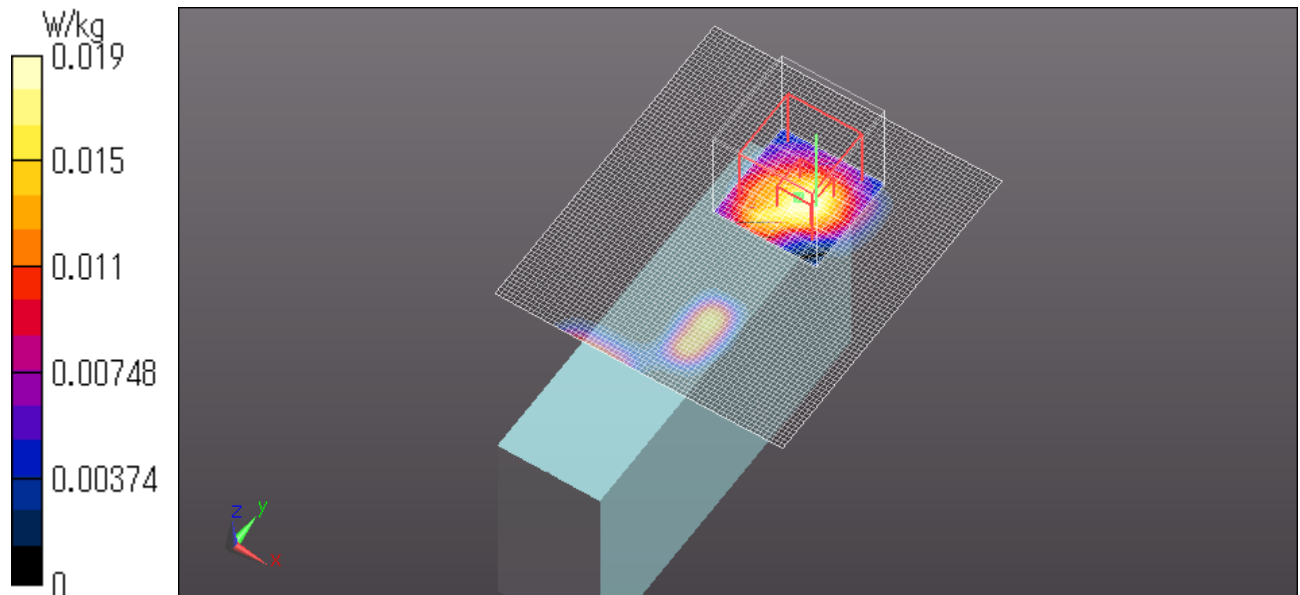

UL Japan, Inc.

Head Office EMC Lab.

4383-326 Asama-cho, Ise-shi, Mie-ken 516-0021 JAPAN

Telephone: +81 596 24 8116

Facsimile: +81 596 24 8124

SG7A2 WLAN 11b 2Mbps Bottom 0mm 2462MHz

Communication System: WLAN 11a/b/g/n ; Communication System Band: WLAN 11b/g/n; Frequency: 2462 MHz; Duty Cycle: 1:1

Medium parameters used (interpolated): $f = 2462$ MHz; $\sigma = 2$ mho/m; $\epsilon_r = 50.444$; $\rho = 1000$ kg/m³

Phantom section: Flat Section

Measurement Standard: DASY5 (IEEE/IEC/ANSI C63.19-2007)

DASY5 Configuration

Probe: EX3DV4 - SN3825; ConvF(7.33, 7.33, 7.33); Calibrated: 2012/12/10; {Probe: Calibration Date}

Sensor-Surface: 2mm (Mechanical Surface Detection)

Electronics: DAE4 Sn509; Calibrated: 2012/07/13

Phantom: ELI 4.0; Type: QDOVA001BA; Serial: xxxx

Measurement SW: DASY52, Version 52.8 (3);

Area Scan (71x81x1): Interpolated grid: dx=1.200 mm, dy=1.200 mm

Maximum value of SAR (interpolated) = 0.0313 W/kg

Zoom Scan (7x7x7)/Cube 0: Measurement grid: dx=5mm, dy=5mm, dz=5mm

Reference Value = 2.762 V/m; Power Drift = -0.09 dB

Peak SAR (extrapolated) = 0.0400 W/kg

SAR(1 g) = 0.017 W/kg; SAR(10 g) = 0.00825 W/kg

Maximum value of SAR (measured) = 0.0264 W/kg

Date: 2013/03/01

Ambient Temp. : 24.0 degree.C. Liquid Temp.; 23.5 degree.C.

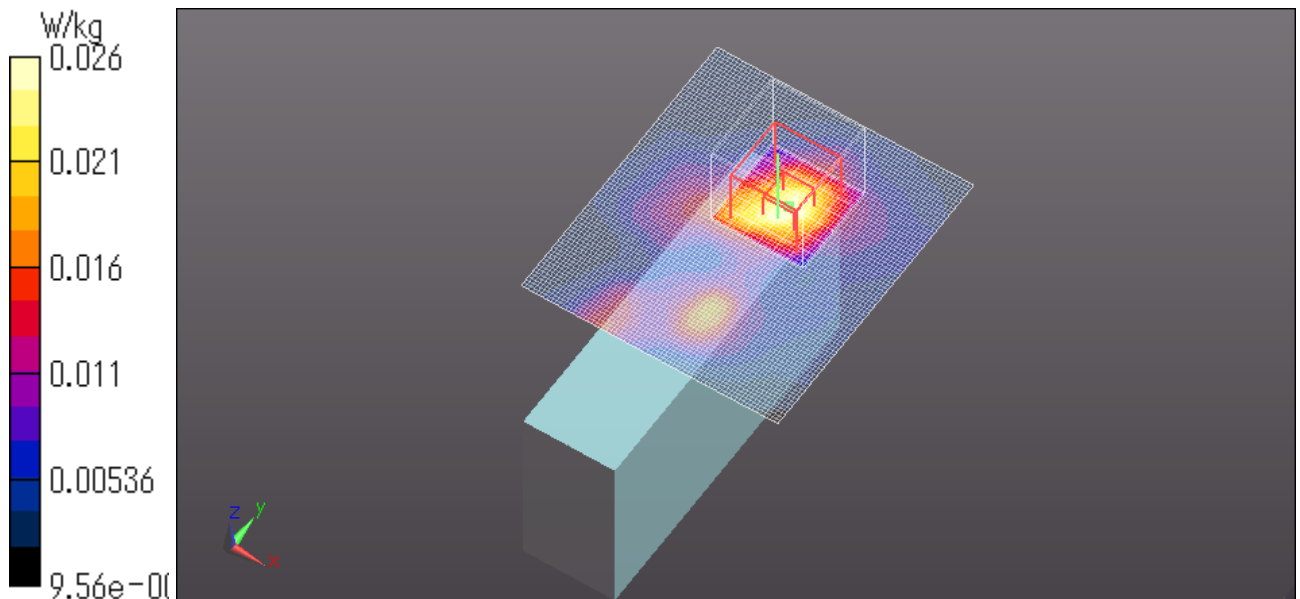

SG7A2 WLAN 11b 2Mbps Top 0mm 2462MHz

Communication System: WLAN 11a/b/g/n ; Communication System Band: WLAN 11b/g/n; Frequency: 2462 MHz; Duty Cycle: 1:1

Medium parameters used (interpolated): $f = 2462$ MHz; $\sigma = 2$ mho/m; $\epsilon_r = 50.444$; $\rho = 1000$ kg/m³

Phantom section: Flat Section

Measurement Standard: DASYS (IEEE/IEC/ANSI C63.19-2007)

DASY5 Configuration

Probe: EX3DV4 - SN3825; ConvF(7.33, 7.33, 7.33); Calibrated: 2012/12/10; {Probe: Calibration Date}

Sensor-Surface: 2mm (Mechanical Surface Detection)

Electronics: DAE4 Sn509; Calibrated: 2012/07/13

Phantom: ELI 4.0; Type: QDOVA001BA; Serial: xxxx

Measurement SW: DASYS2, Version 52.8 (3);

Area Scan (71x81x1): Interpolated grid: dx=1.200 mm, dy=1.200 mm

Maximum value of SAR (interpolated) = 0.225 W/kg

Zoom Scan (7x7x7)/Cube 0: Measurement grid: dx=5mm, dy=5mm, dz=5mm

Reference Value = 6.102 V/m; Power Drift = -0.14 dB

Peak SAR (extrapolated) = 0.273 W/kg

SAR(1 g) = 0.125 W/kg; SAR(10 g) = 0.057 W/kg

Maximum value of SAR (measured) = 0.198 W/kg

Date: 2013/03/01

Ambient Temp. : 24.0 degree.C. Liquid Temp.; 23.5 degree.C.

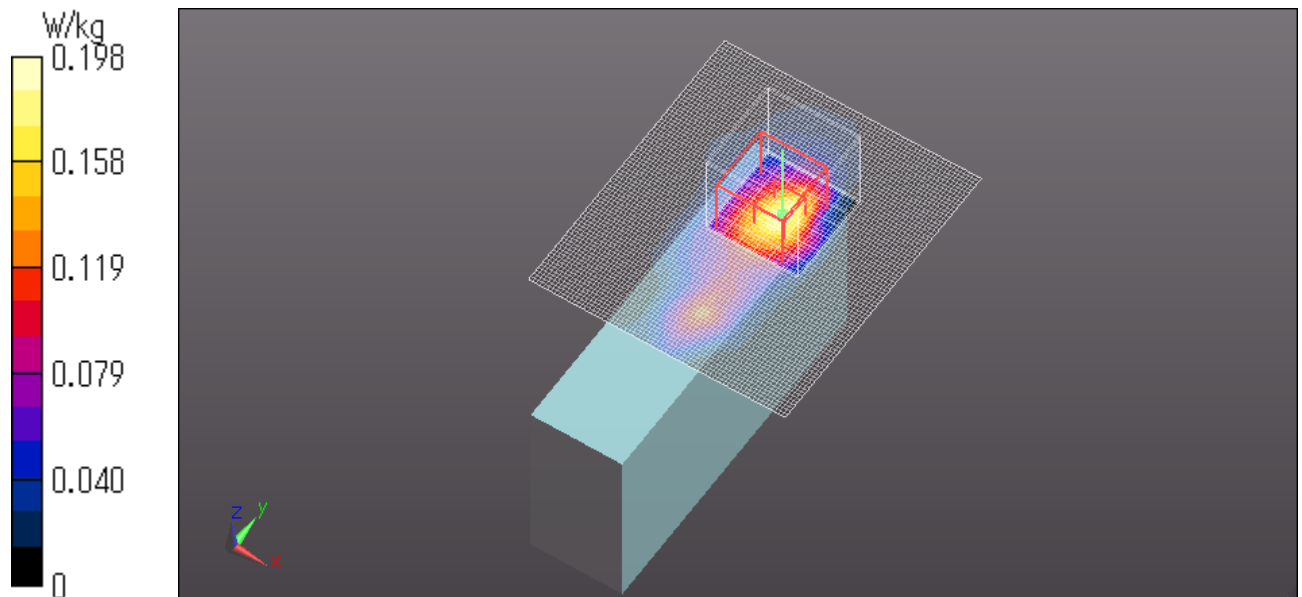

SG7A2 WLAN 11b 2Mbps Front 0mm 2462MHz

Communication System: WLAN 11a/b/g/n ; Communication System Band: WLAN 11b/g/n; Frequency: 2462 MHz; Duty Cycle: 1:1

Medium parameters used (interpolated): $f = 2462$ MHz; $\sigma = 2$ mho/m; $\epsilon_r = 50.444$; $\rho = 1000$ kg/m³

Phantom section: Flat Section

Measurement Standard: DASYS (IEEE/IEC/ANSI C63.19-2007)

DASY5 Configuration

Probe: EX3DV4 - SN3825; ConvF(7.33, 7.33, 7.33); Calibrated: 2012/12/10; {Probe: Calibration Date}

Sensor-Surface: 2mm (Mechanical Surface Detection)

Electronics: DAE4 Sn509; Calibrated: 2012/07/13

Phantom: ELI 4.0; Type: QDOVA001BA; Serial: xxxx

Measurement SW: DASYS2, Version 52.8 (3);

Area Scan (71x81x1): Interpolated grid: dx=1.200 mm, dy=1.200 mm

Maximum value of SAR (interpolated) = 0.426 W/kg

Zoom Scan (7x7x7)/Cube 0: Measurement grid: dx=5mm, dy=5mm, dz=5mm

Reference Value = 2.459 V/m; Power Drift = -0.09 dB

Peak SAR (extrapolated) = 0.530 W/kg

SAR(1 g) = 0.279 W/kg; SAR(10 g) = 0.095 W/kg

Maximum value of SAR (measured) = 0.441 W/kg

Date: 2013/03/01

Ambient Temp. : 24.0 degree.C. Liquid Temp.; 23.5 degree.C.

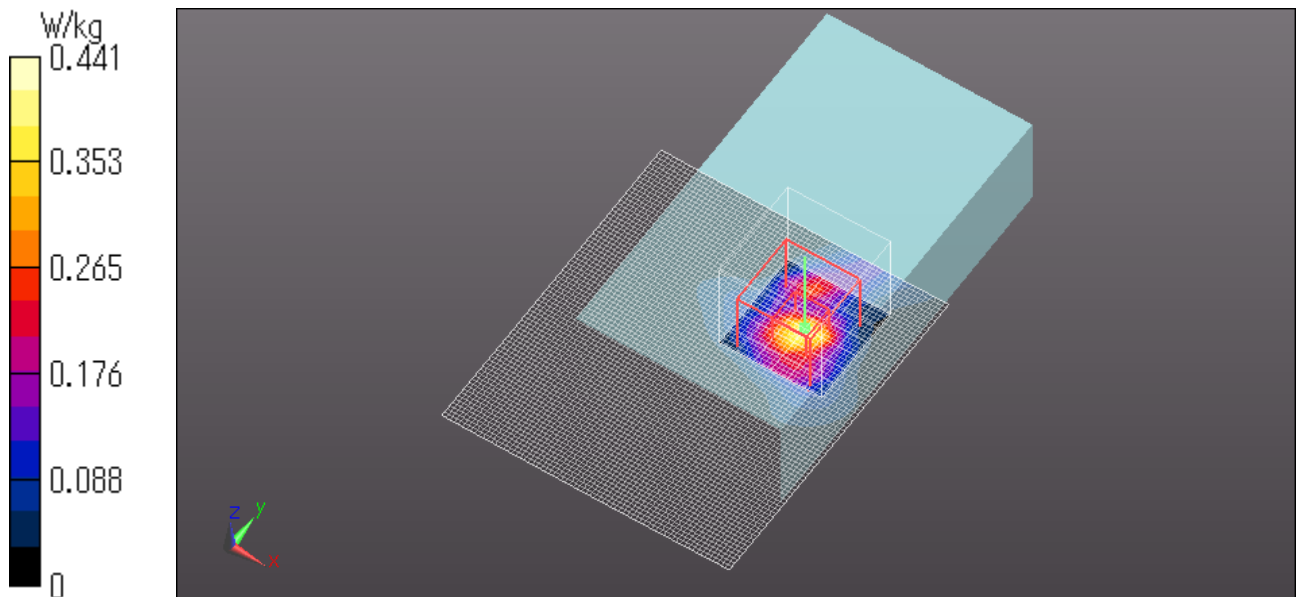

Z scan at maximum SAR location WLAN(Body)

SG7A2 WLAN 11b 2Mbps Front 0mm 2462MHz

Communication System: WLAN 11a/b/g/n ; Communication System Band: WLAN 11b/g/n; Frequency: 2462 MHz;Duty Cycle: 1:1

Medium parameters used (interpolated): $f = 2462$ MHz; $\sigma = 2$ mho/m; $\epsilon_r = 50.444$; $\rho = 1000$ kg/m³

Phantom section: Flat Section

Measurement Standard: DASYS (IEEE/IEC/ANSI C63.19-2007)

DASY5 Configuration

Probe: EX3DV4 - SN3825; ConvF(7.33, 7.33, 7.33); Calibrated: 2012/12/10; \${Probe: Calibration Date}

Sensor-Surface: 2mm (Mechanical Surface Detection)

Electronics: DAE4 Sn509; Calibrated: 2012/07/13

Phantom: ELI 4.0; Type: QDOVA001BA; Serial: xxxx

Measurement SW: DASYS2, Version 52.8 (3);

Z Scan (1x1x31): Measurement grid: dx=20mm, dy=20mm, dz=5mm

Maximum value of SAR (measured) = 0.0211 W/kg

Date: 2013/03/01

Ambient Temp. : 24.0 degree.C. Liquid Temp.; 23.5 degree.C.

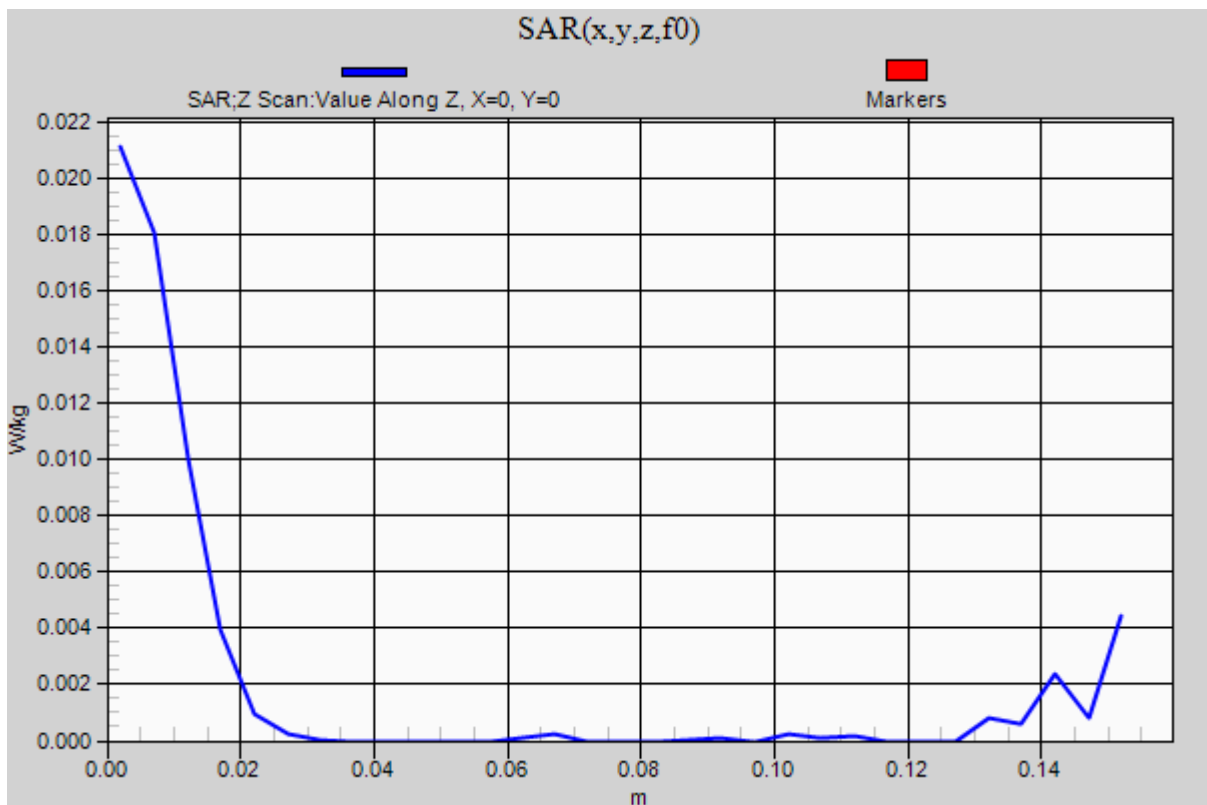

UL Japan, Inc.

Head Office EMC Lab.

4383-326 Asama-cho, Ise-shi, Mie-ken 516-0021 JAPAN

Telephone: +81 596 24 8116

Facsimile: +81 596 24 8124

SG7A2 WLAN 11b 2Mbps Rear 0mm 2462MHz

Communication System: WLAN 11a/b/g/n ; Communication System Band: WLAN 11b/g/n; Frequency: 2462 MHz; Duty Cycle: 1:1

Medium parameters used (interpolated): $f = 2462$ MHz; $\sigma = 2$ mho/m; $\epsilon_r = 50.444$; $\rho = 1000$ kg/m³

Phantom section: Flat Section

Measurement Standard: DASYS (IEEE/IEC/ANSI C63.19-2007)

DASY5 Configuration

Probe: EX3DV4 - SN3825; ConvF(7.33, 7.33, 7.33); Calibrated: 2012/12/10; \${Probe: Calibration Date}

Sensor-Surface: 2mm (Mechanical Surface Detection (Locations From Previous Scan Used)), Sensor-Surface: 2mm (Mechanical Surface Detection)

Electronics: DAE4 Sn509; Calibrated: 2012/07/13

Phantom: ELI 4.0; Type: QDOVA001BA; Serial: xxxx

Measurement SW: DASYS2, Version 52.8 (3);

Area Scan (71x81x1): Interpolated grid: dx=1.200 mm, dy=1.200 mm

Maximum value of SAR (interpolated) = 0.0912 W/kg

Zoom Scan (7x7x7)/Cube 0: Measurement grid: dx=5mm, dy=5mm, dz=5mm

Reference Value = 1.091 V/m; Power Drift = 0.11 dB

Peak SAR (extrapolated) = 0.129 W/kg

SAR(1 g) = 0.057 W/kg; SAR(10 g) = 0.025 W/kg

Maximum value of SAR (measured) = 0.0923 W/kg

Date: 2013/03/01

Ambient Temp. : 24.0 degree.C. Liquid Temp.; 23.5 degree.C.

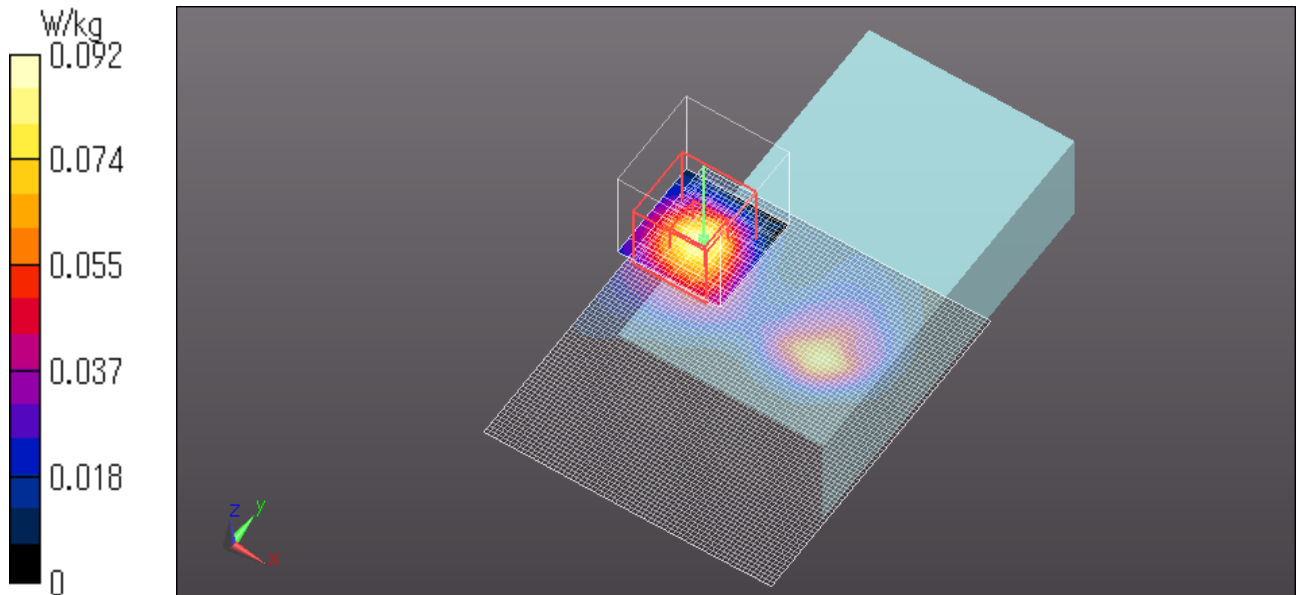

UL Japan, Inc.

Head Office EMC Lab.

4383-326 Asama-cho, Ise-shi, Mie-ken 516-0021 JAPAN

Telephone: +81 596 24 8116

Facsimile: +81 596 24 8124

SG7A2 WLAN 11b 2Mbps Left Side 0mm 2462MHz

Communication System: WLAN 11a/b/g/n ; Communication System Band: WLAN 11b/g/n; Frequency: 2462 MHz; Duty Cycle: 1:1

Medium parameters used (interpolated): $f = 2462$ MHz; $\sigma = 2$ mho/m; $\epsilon_r = 50.444$; $\rho = 1000$ kg/m³

Phantom section: Flat Section

Measurement Standard: DASYS (IEEE/IEC/ANSI C63.19-2007)

DASY5 Configuration

Probe: EX3DV4 - SN3825; ConvF(7.33, 7.33, 7.33); Calibrated: 2012/12/10; {Probe: Calibration Date}

Sensor-Surface: 2mm (Mechanical Surface Detection)

Electronics: DAE4 Sn509; Calibrated: 2012/07/13

Phantom: ELI 4.0; Type: QDOVA001BA; Serial: xxxx

Measurement SW: DASYS2, Version 52.8 (3);

Area Scan (71x101x1): Interpolated grid: dx=1.200 mm, dy=1.200 mm

Maximum value of SAR (interpolated) = 0.106 W/kg

Zoom Scan (7x7x7)/Cube 0: Measurement grid: dx=5mm, dy=5mm, dz=5mm

Reference Value = 3.161 V/m; Power Drift = -0.17 dB

Peak SAR (extrapolated) = 0.0820 W/kg

SAR(1 g) = 0.040 W/kg; SAR(10 g) = 0.016 W/kg

Maximum value of SAR (measured) = 0.0618 W/kg

Date: 2013/03/01

Ambient Temp. : 24.0 degree.C. Liquid Temp.; 23.5 degree.C.

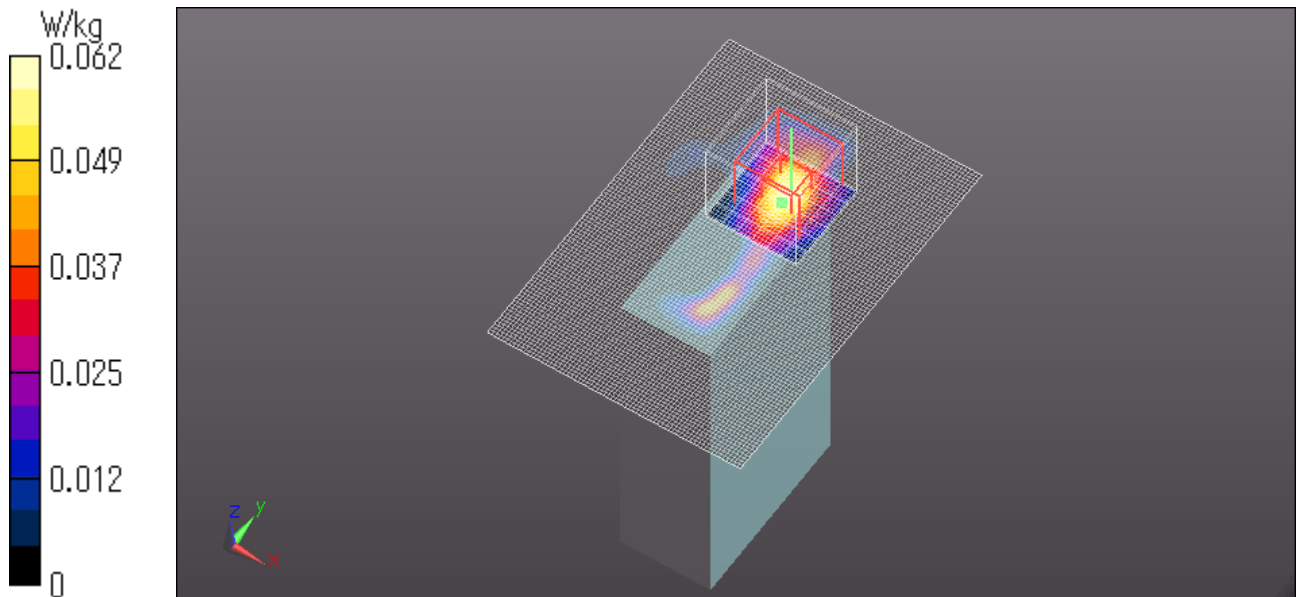

APPENDIX 2 : System Validation**1 System validation result for 2450MHz****System validation result Body 2450****Simulated Tissue Liquid Parameter confirmation**

DIELECTRIC PARAMETERS MEASUREMENT RESULTS										
Date	Ambient Temp. [deg.c]	Relative Humidity [%]	Liquid type	Liquid Temp. [deg.c]	Measured Frequency [MHz]	Parameters	Target Value*1	Measured	Deviation [%]	Limit [%]
1-Mar	24.0	42	MSL 2450	23.5	2450	ϵ_r	52.7	50.5	-4.2	+/-5
						σ [mho/m]	1.95	1.98	1.6	+/-5

ϵ_r : Relative Permittivity / σ : Conductivity

*1 The Target value is a parameter defined in FCC OET65.

DIELECTRIC PARAMETERS MEASUREMENT RESULTS										
Date	Ambient Temp. [deg.c]	Relative Humidity [%]	Liquid type	Liquid Temp. [deg.c]	Measured Frequency [MHz]	Parameters	Target Value*2	Measured	Deviation [%]	Limit*3 [%]
1-Mar	24.0	42	MSL 2450	23.5	2450	ϵ_r	52.5	50.5	-3.8	+/-6
						σ [mho/m]	1.95	1.98	1.6	+/-6

ϵ_r : Relative Permittivity / σ : Conductivity

*2 The target value is the calibrated dipole Body TSL parameters. (D2450V2 SN:713, Measured Body TSL parameters)

*3 The limit is for deviation provided by manufacture.

System validation result (for calibration by manufacture)

SYSTEM VALIDATION							
Date	Frequency [MHz]	SAR 1g [W/kg]			Target 1W *1	Deviation [%]	Limit [%]
		Forward Power 250mW	Conversion 1W				
		Measured	Calculation				
1-Mar	2450.00	13.90	55.60		51.90	7.1	+/-10

*1 The target value is the parameter defined in 1g SAR (normalizes to 1W) in manufacturer calibrated dipole (D2450V2 SN:713)

UL Japan, Inc.

Head Office EMC Lab.

4383-326 Asama-cho, Ise-shi, Mie-ken 516-0021 JAPAN

Telephone: +81 596 24 8116

Facsimile: +81 596 24 8124

Body 2450MHz System Validation DATA / Dipole2.4GHz / Forward Conducted Power : 250mW

Communication System: CW; Communication System Band: D2450 (2450.0 MHz); Frequency: 2450 MHz;Duty Cycle: 1:1

Medium parameters used: $f = 2450$ MHz; $\sigma = 1.984$ mho/m; $\epsilon_r = 50.486$; $\rho = 1000$ kg/m³

Phantom section: Flat Section

Measurement Standard: DASY5 (IEEE/IEC/ANSI C63.19-2007)

DASY5 Configuration

Probe: EX3DV4 - SN3825; ConvF(7.33, 7.33, 7.33); Calibrated: 2012/12/10; \${Probe: Calibration Date}

Sensor-Surface: 2mm (Mechanical Surface Detection)

Electronics: DAE4 Sn509; Calibrated: 2012/07/13

Phantom: ELI 4.0; Type: QDOVA001BA; Serial: xxxx

Measurement SW: DASY52, Version 52.8 (3);

Area Scan (81x81x1): Interpolated grid: dx=1.200 mm, dy=1.200 mm

Maximum value of SAR (interpolated) = 21.8 W/kg

Zoom Scan (7x7x7)/Cube 0: Measurement grid: dx=5mm, dy=5mm, dz=5mm

Reference Value = 105.3 V/m; Power Drift = -0.05 dB

Peak SAR (extrapolated) = 30.0 W/kg

SAR(1 g) = 13.9 W/kg; SAR(10 g) = 6.28 W/kg

Maximum value of SAR (measured) = 21.6 W/kg

Date: 2013/03/01

Ambient Temp. : 24.0 degree.C. Liquid Temp.; 23.5 degree.C.

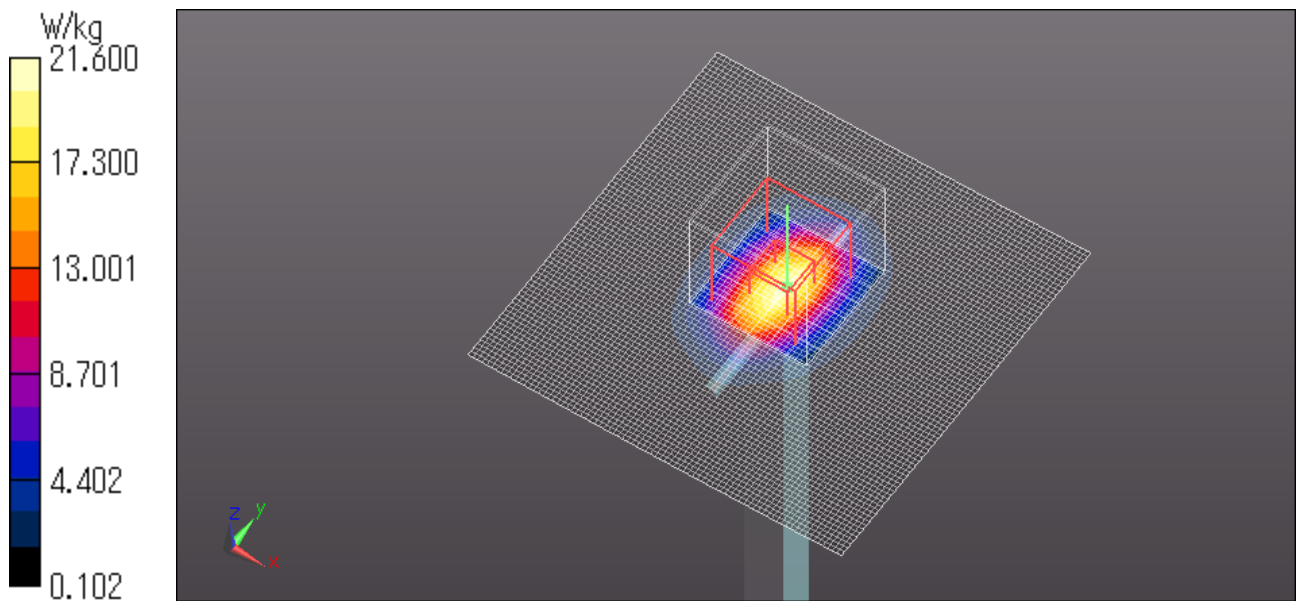

UL Japan, Inc.

Head Office EMC Lab.

4383-326 Asama-cho, Ise-shi, Mie-ken 516-0021 JAPAN

Telephone: +81 596 24 8116

Facsimile: +81 596 24 8124

2. System Validation Dipole (D2450V2,S/N:713)

Calibration Laboratory of
Schmid & Partner
Engineering AG
Zeughausstrasse 43, 8004 Zurich, Switzerland



S Schweizerischer Kalibrierdienst
C Service suisse d'étalonnage
C Servizio svizzero di taratura
S Swiss Calibration Service

Accredited by the Swiss Accreditation Service (SAS)
The Swiss Accreditation Service is one of the signatories to the EA
Multilateral Agreement for the recognition of calibration certificates

Accreditation No.: SCS 108

Client **UL Japan (PTF)**

Certificate No: **D2450V2-713_Sep10**

CALIBRATION CERTIFICATE																																															
Object	D2450V2 - SN-713																																														
Calibration procedure(s)	QA CAL-05.v7 Calibration procedure for dipole validation kits																																														
Calibration date:	September 06, 2010																																														
<p>This calibration certificate documents the traceability to national standards, which realize the physical units of measurements (SI). The measurements and the uncertainties with confidence probability are given on the following pages and are part of the certificate.</p> <p>All calibrations have been conducted in the closed laboratory facility: environment temperature (22 ± 3)°C and humidity < 70%.</p> <p>Calibration Equipment used (M&TE critical for calibration)</p> <table border="1"> <thead> <tr> <th>Primary Standards</th> <th>ID #</th> <th>Cal Date (Certificate No.)</th> <th>Scheduled Calibration</th> </tr> </thead> <tbody> <tr> <td>Power meter EPM-442A</td> <td>GB37480704</td> <td>06-Oct-09 (No. 217-01086)</td> <td>Oct-10</td> </tr> <tr> <td>Power sensor HP 8481A</td> <td>US37292783</td> <td>08-Oct-09 (No. 217-01086)</td> <td>Oct-10</td> </tr> <tr> <td>Reference 20 dB Attenuator</td> <td>SN: 5086 (20g)</td> <td>30-Mar-10 (No. 217-01158)</td> <td>Mar-11</td> </tr> <tr> <td>Type-N mismatch combination</td> <td>SN: 5047.2 / 06327</td> <td>30-Mar-10 (No. 217-01162)</td> <td>Mar-11</td> </tr> <tr> <td>Reference Probe ES3DV3</td> <td>SN: 3205</td> <td>30-Apr-10 (No. ES3-3205_Apr10)</td> <td>Apr-11</td> </tr> <tr> <td>DAE4</td> <td>SN: 601</td> <td>10-Jun-10 (No. DAE4-601_Jun10)</td> <td>Jun-11</td> </tr> </tbody> </table> <table border="1"> <thead> <tr> <th>Secondary Standards</th> <th>ID #</th> <th>Check Date (in house)</th> <th>Scheduled Check</th> </tr> </thead> <tbody> <tr> <td>Power sensor HP 8481A</td> <td>MY41092317</td> <td>18-Oct-02 (in house check Oct-09)</td> <td>In house check: Oct-11</td> </tr> <tr> <td>RF generator R&S SMT-06</td> <td>100005</td> <td>4-Aug-99 (in house check Oct-09)</td> <td>In house check: Oct-11</td> </tr> <tr> <td>Network Analyzer HP 8753E</td> <td>US37390585 S4206</td> <td>18-Oct-01 (in house check Oct-09)</td> <td>In house check: Oct-10</td> </tr> </tbody> </table>				Primary Standards	ID #	Cal Date (Certificate No.)	Scheduled Calibration	Power meter EPM-442A	GB37480704	06-Oct-09 (No. 217-01086)	Oct-10	Power sensor HP 8481A	US37292783	08-Oct-09 (No. 217-01086)	Oct-10	Reference 20 dB Attenuator	SN: 5086 (20g)	30-Mar-10 (No. 217-01158)	Mar-11	Type-N mismatch combination	SN: 5047.2 / 06327	30-Mar-10 (No. 217-01162)	Mar-11	Reference Probe ES3DV3	SN: 3205	30-Apr-10 (No. ES3-3205_Apr10)	Apr-11	DAE4	SN: 601	10-Jun-10 (No. DAE4-601_Jun10)	Jun-11	Secondary Standards	ID #	Check Date (in house)	Scheduled Check	Power sensor HP 8481A	MY41092317	18-Oct-02 (in house check Oct-09)	In house check: Oct-11	RF generator R&S SMT-06	100005	4-Aug-99 (in house check Oct-09)	In house check: Oct-11	Network Analyzer HP 8753E	US37390585 S4206	18-Oct-01 (in house check Oct-09)	In house check: Oct-10
Primary Standards	ID #	Cal Date (Certificate No.)	Scheduled Calibration																																												
Power meter EPM-442A	GB37480704	06-Oct-09 (No. 217-01086)	Oct-10																																												
Power sensor HP 8481A	US37292783	08-Oct-09 (No. 217-01086)	Oct-10																																												
Reference 20 dB Attenuator	SN: 5086 (20g)	30-Mar-10 (No. 217-01158)	Mar-11																																												
Type-N mismatch combination	SN: 5047.2 / 06327	30-Mar-10 (No. 217-01162)	Mar-11																																												
Reference Probe ES3DV3	SN: 3205	30-Apr-10 (No. ES3-3205_Apr10)	Apr-11																																												
DAE4	SN: 601	10-Jun-10 (No. DAE4-601_Jun10)	Jun-11																																												
Secondary Standards	ID #	Check Date (in house)	Scheduled Check																																												
Power sensor HP 8481A	MY41092317	18-Oct-02 (in house check Oct-09)	In house check: Oct-11																																												
RF generator R&S SMT-06	100005	4-Aug-99 (in house check Oct-09)	In house check: Oct-11																																												
Network Analyzer HP 8753E	US37390585 S4206	18-Oct-01 (in house check Oct-09)	In house check: Oct-10																																												
Calibrated by:	Name Claudio Leubler	Function Laboratory Technician	Signature 																																												
Approved by:	Name Katja Pokovic	Function Technical Manager	Signature 																																												
			Issued: September 8, 2010																																												
This calibration certificate shall not be reproduced except in full without written approval of the laboratory.																																															

**Calibration Laboratory of
Schmid & Partner
Engineering AG**
Zeughausstrasse 43, 8004 Zurich, Switzerland



S Schweizerischer Kalibrierdienst
C Service suisse d'étalonnage
S Servizio svizzero di taratura
S Swiss Calibration Service

Accredited by the Swiss Accreditation Service (SAS)
The Swiss Accreditation Service is one of the signatories to the EA
Multilateral Agreement for the recognition of calibration certificates

Accreditation No.: **SCS 108**

Glossary:

TSL tissue simulating liquid
ConvF sensitivity in TSL / NORM x,y,z
N/A not applicable or not measured

Calibration is Performed According to the Following Standards:

- a) IEEE Std 1528-2003, "IEEE Recommended Practice for Determining the Peak Spatial-Averaged Specific Absorption Rate (SAR) in the Human Head from Wireless Communications Devices: Measurement Techniques", December 2003
- b) IEC 62209-1, "Procedure to measure the Specific Absorption Rate (SAR) for hand-held devices used in close proximity to the ear (frequency range of 300 MHz to 3 GHz)", February 2005
- c) Federal Communications Commission Office of Engineering & Technology (FCC OET), "Evaluating Compliance with FCC Guidelines for Human Exposure to Radiofrequency Electromagnetic Fields; Additional Information for Evaluating Compliance of Mobile and Portable Devices with FCC Limits for Human Exposure to Radiofrequency Emissions", Supplement C (Edition 01-01) to Bulletin 65

Additional Documentation:

- d) DASY4/5 System Handbook

Methods Applied and Interpretation of Parameters:

- *Measurement Conditions:* Further details are available from the Validation Report at the end of the certificate. All figures stated in the certificate are valid at the frequency indicated.
- *Antenna Parameters with TSL:* The dipole is mounted with the spacer to position its feed point exactly below the center marking of the flat phantom section, with the arms oriented parallel to the body axis.
- *Feed Point Impedance and Return Loss:* These parameters are measured with the dipole positioned under the liquid filled phantom. The impedance stated is transformed from the measurement at the SMA connector to the feed point. The Return Loss ensures low reflected power. No uncertainty required.
- *Electrical Delay:* One-way delay between the SMA connector and the antenna feed point. No uncertainty required.
- *SAR measured:* SAR measured at the stated antenna input power.
- *SAR normalized:* SAR as measured, normalized to an input power of 1 W at the antenna connector.
- *SAR for nominal TSL parameters:* The measured TSL parameters are used to calculate the nominal SAR result.

UL Japan, Inc.

Head Office EMC Lab.

4383-326 Asama-cho, Ise-shi, Mie-ken 516-0021 JAPAN

Telephone: +81 596 24 8116

Facsimile: +81 596 24 8124

Measurement Conditions

DASY system configuration, as far as not given on page 1.

DASY Version	DASY5	V52.2
Extrapolation	Advanced Extrapolation	
Phantom	Modular Flat Phantom V5.0	
Distance Dipole Center - TSL	10 mm	with Spacer
Zoom Scan Resolution	dx, dy, dz = 5 mm	
Frequency	2450 MHz \pm 1 MHz	

Head TSL parameters

The following parameters and calculations were applied.

	Temperature	Permittivity	Conductivity
Nominal Head TSL parameters	22.0 °C	39.2	1.80 mho/m
Measured Head TSL parameters	(22.0 \pm 0.2) °C	39.0 \pm 6 %	1.74 mho/m \pm 6 %
Head TSL temperature during test	(21.8 \pm 0.2) °C	----	----

SAR result with Head TSL

SAR averaged over 1 cm ³ (1 g) of Head TSL	Condition	
SAR measured	250 mW input power	12.9 mW / g
SAR normalized	normalized to 1W	51.6 mW / g
SAR for nominal Head TSL parameters	normalized to 1W	52.4 mW /g \pm 17.0 % (k=2)

SAR averaged over 10 cm ³ (10 g) of Head TSL	condition	
SAR measured	250 mW input power	6.08 mW / g
SAR normalized	normalized to 1W	24.3 mW / g
SAR for nominal Head TSL parameters	normalized to 1W	24.4 mW /g \pm 16.5 % (k=2)

Body TSL parameters

The following parameters and calculations were applied.

	Temperature	Permittivity	Conductivity
Nominal Body TSL parameters	22.0 °C	52.7	1.95 mho/m
Measured Body TSL parameters	(22.0 ± 0.2) °C	52.5 ± 6 %	1.95 mho/m ± 6 %
Body TSL temperature during test	(22.0 ± 0.2) °C	----	----

SAR result with Body TSL

SAR averaged over 1 cm ³ (1 g) of Body TSL	Condition	
SAR measured	250 mW input power	13.0 mW / g
SAR normalized	normalized to 1W	52.0 mW / g
SAR for nominal Body TSL parameters	normalized to 1W	51.9 mW / g ± 17.0 % (k=2)

SAR averaged over 10 cm ³ (10 g) of Body TSL	condition	
SAR measured	250 mW input power	6.04 mW / g
SAR normalized	normalized to 1W	24.2 mW / g
SAR for nominal Body TSL parameters	normalized to 1W	24.1 mW / g ± 16.5 % (k=2)

Appendix

Antenna Parameters with Head TSL

Impedance, transformed to feed point	53.0 Ω + 1.0 j Ω
Return Loss	- 30.4 dB

Antenna Parameters with Body TSL

Impedance, transformed to feed point	49.6 Ω + 2.1 j Ω
Return Loss	- 33.5 dB

General Antenna Parameters and Design

Electrical Delay (one direction)	1.160 ns
----------------------------------	----------

After long term use with 100W radiated power, only a slight warming of the dipole near the feedpoint can be measured.

The dipole is made of standard semirigid coaxial cable. The center conductor of the feeding line is directly connected to the second arm of the dipole. The antenna is therefore short-circuited for DC-signals.

No excessive force must be applied to the dipole arms, because they might bend or the soldered connections near the feedpoint may be damaged.

Additional EUT Data

Manufactured by	SPEAG
Manufactured on	July 05, 2002

DASY5 Validation Report for Head TSL

Date/Time: 03.09.2010 15:07:26

Test Laboratory: SPEAG, Zurich, Switzerland

DUT: Dipole 2450 MHz; Type: D2450V2; Serial: D2450V2 - SN:713

Communication System: CW; Frequency: 2450 MHz; Duty Cycle: 1:1

Medium: HSL U12 BB

Medium parameters used: $f = 2450$ MHz; $\sigma = 1.74$ mho/m; $\epsilon_r = 39$; $\rho = 1000$ kg/m³

Phantom section: Flat Section

Measurement Standard: DASY5 (IEEE/IEC/ANSI C63.19-2007)

DASY5 Configuration:

- Probe: ES3DV3 - SN3205; ConvF(4.53, 4.53, 4.53); Calibrated: 30.04.2010
- Sensor-Surface: 3mm (Mechanical Surface Detection)
- Electronics: DAE4 Sn601; Calibrated: 10.06.2010
- Phantom: Flat Phantom 5.0 (front); Type: QD000P50AA; Serial: 1001
- Measurement SW: DASY52, V52.2 Build 0, Version 52.2.0 (163)
- Postprocessing SW: SEMCAD X, V14.2 Build 2, Version 14.2.2 (1685)

Head/d=10mm, Pin=250 mW, dist=3.0mm (ES-Probe)/Zoom Scan (7x7x7) (7x7x7)/Cube 0:

Measurement grid: dx=5mm, dy=5mm, dz=5mm

Reference Value = 100.4 V/m; Power Drift = 0.050 dB

Peak SAR (extrapolated) = 26.3 W/kg

SAR(1 g) = 12.9 mW/g; SAR(10 g) = 6.08 mW/g

Maximum value of SAR (measured) = 16.2 mW/g



0 dB = 16.2mW/g

Impedance Measurement Plot for Head TSL

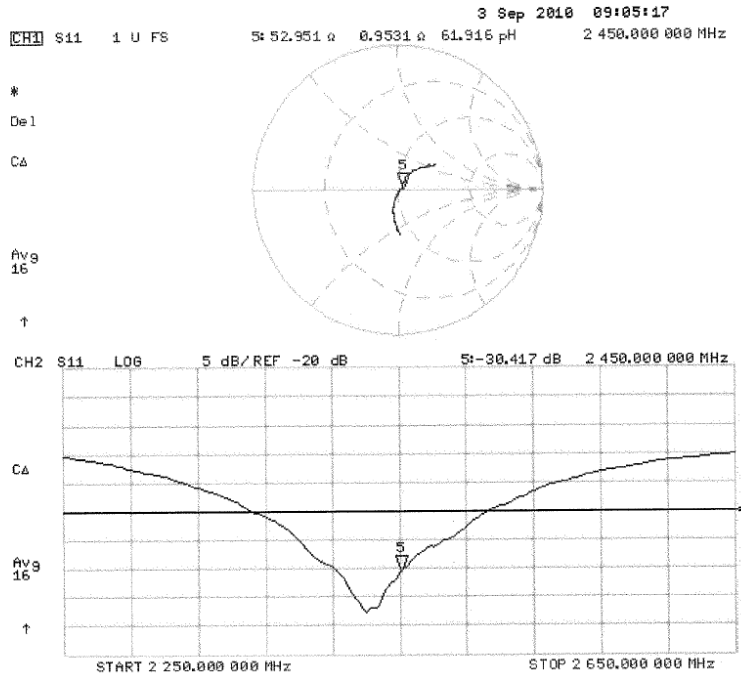

Validation Report for Body

Date/Time: 06.09.2010 13:42:13

Test Laboratory: SPEAG, Zurich, Switzerland

DUT: Dipole 2450 MHz; Type: D2450V2; Serial: D2450V2 - SN:713

Communication System: CW; Frequency: 2450 MHz; Duty Cycle: 1:1

Medium: MSL U12 BB

Medium parameters used: $f = 2450$ MHz; $\sigma = 1.95$ mho/m; $\epsilon_r = 52.5$; $\rho = 1000$ kg/m³

Phantom section: Flat Section

Measurement Standard: DASYS (IEEE/IEC/ANSI C63.19-2007)

DASY5 Configuration:

- Probe: ES3DV3 - SN3205; ConvF(4.31, 4.31, 4.31); Calibrated: 30.04.2010
- Sensor-Surface: 3mm (Mechanical Surface Detection)
- Electronics: DAE4 Sn601; Calibrated: 10.06.2010
- Phantom: Flat Phantom 5.0 (back); Type: QD000P50AA; Serial: 1002
- Measurement SW: DASY52, V52.2 Build 0, Version 52.2.0 (163)
- Postprocessing SW: SEMCAD X, V14.2 Build 2, Version 14.2.2 (1685)

Body/d=10mm, Pin=250 mW, dist=3.0mm (ES-Probe)/Zoom Scan (7x7x7) (7x7x7)/Cube 0:

Measurement grid: dx=5mm, dy=5mm, dz=5mm

Reference Value = 95.7 V/m; Power Drift = 0.030 dB

Peak SAR (extrapolated) = 27 W/kg

SAR(1 g) = 13 mW/g; SAR(10 g) = 6.04 mW/g

Maximum value of SAR (measured) = 16.9 mW/g

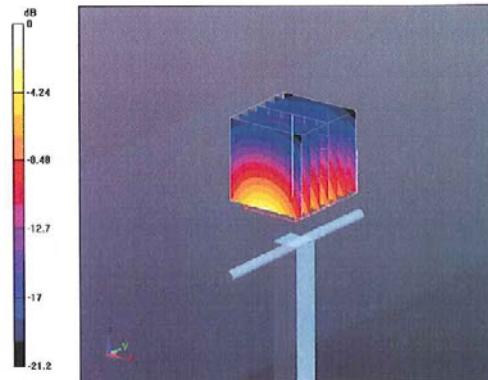

0 dB = 16.9mW/g

Impedance Measurement Plot for Body TSL

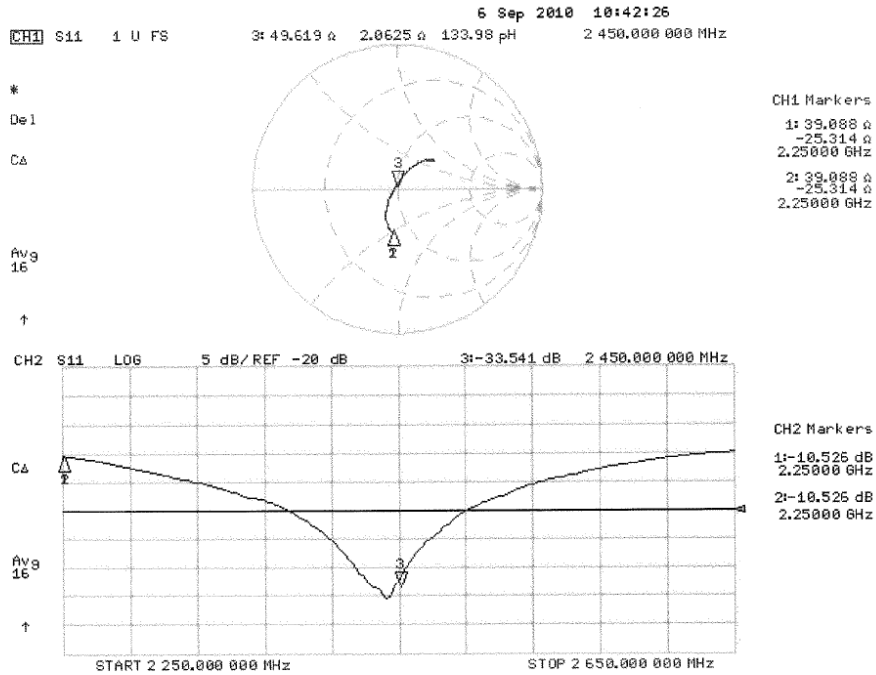

D2450V2 Calibration for Impedance and Return-loss

Date	Septembert 21, 2012		
Ambient Temperature	24.5 deg.C	Relative humidity	58%RH

1. Test environment

Equipment	Dipole Antenna	Model	D2450V2
Manufacture	Schmid&Partner Engineering AG	Serial	713
Tested by	Hisayoshi Sato/ISE/ULI		

2. Equipment used

Control No.	Instrument	Manufacturer	Model No	Serial No	Calibration Date	Expiration date of the calibration
MNA-01	Network Analyzer	Agilent/HP	E8358A	US41080381	2012/09/14	2013/09/30
EST-46	3.5mm Calibration Kit	Agilent	85052D	MY43252869	2012/08/13	2013/08/31
MCC-141	Microwave Cable	Junkosha	MWX221	1203S212(1m)	2012/04/23	2013/04/30
MDA-06	Dipole Antenna	Schmid&Partner Engineering AG	D1800V2	2d040	2010/12/09	2013/12/31
MPSAM-02	SAM Phantom	Schmid&Partner Engineering AG	SAM Twin Phantom V4.0	1333	Pre Check	-
MOS-24	Thermo-Hygrometer	Custom	CTH-201	5	2012/05/14	2013/05/31
HSL2450					Daily check	-
MSL2450					Daily check	-
SAR room					Daily check	-

3. Test Result

Impedance, Transformed to feed point	Head	Deviation	Tolerance	Result
Calibration (SPEAG) 2010/9/06	53.0 Ω +1.0j Ω	-	-	-
Calibration(ULJ)2012/8/21	52.26 Ω -0.43j Ω	-0.74 Ω -1.43j Ω	+/-5 Ω +/-5j Ω	Complied

Return loss	Head	Deviation	Tolerance	Result
Calibration (SPEAG) 2010/9/06	-30.4dB	-	-	-
Calibration(ULJ)2012/8/21	-32.96dB	-2.56dB	30.4 *+/-20%	Complied

Impedance, Transformed to feed point	Body	Deviation	Tolerance	Result
Calibration (SPEAG) 2010/9/06	49.6 Ω +2.1j Ω	-	-	-
Calibration(ULJ)2011/9/13	48.25 Ω +0.29j Ω	-1.35 Ω +1.81j Ω	+/-5 Ω +/-5j Ω	Complied

Return loss	Body	Deviation	Tolerance	Result
Calibration (SPEAG) 2010/9/06	-33.5dB	-	-	-
Calibration(ULJ)2011/9/13	-34.89dB	-1.39dB	33.5*+/-20%	Complied

*Tolerance : According to the KDB450824D02

UL Japan, Inc.

Head Office EMC Lab.

4383-326 Asama-cho, Ise-shi, Mie-ken 516-0021 JAPAN

Telephone: +81 596 24 8116

Facsimile: +81 596 24 8124

Measurement Plots

<Head Liquid>

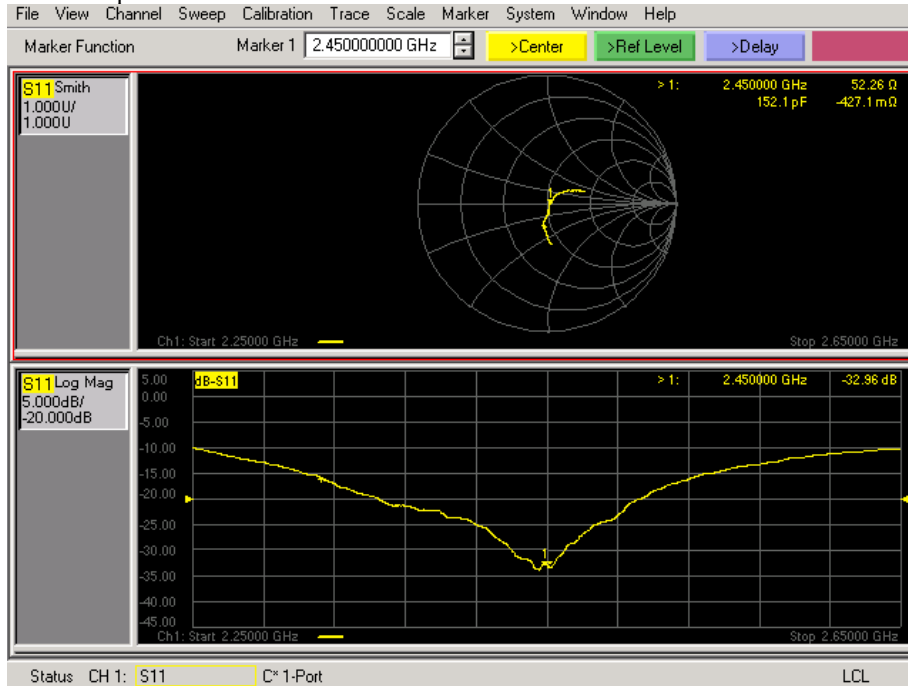

<Body Liquid>

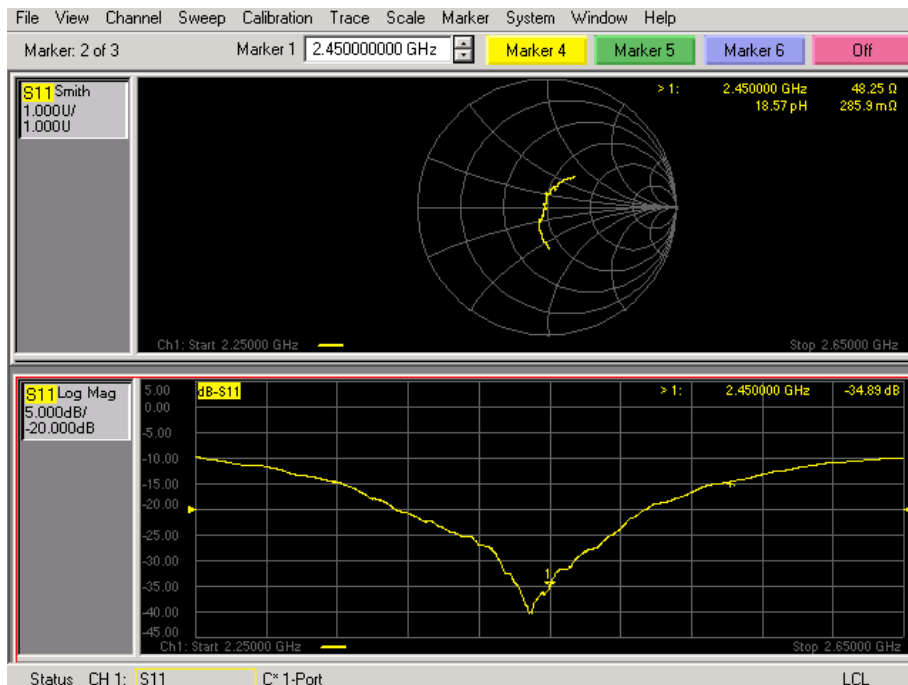

UL Japan, Inc.

Head Office EMC Lab.

4383-326 Asama-cho, Ise-shi, Mie-ken 516-0021 JAPAN

Telephone: +81 596 24 8116

Facsimile: +81 596 24 8124

3. Validation uncertainty

The uncertainty budget has been determined for the DASYS measurement system according to the SPEAG documents[2] and is given in the following Table.

Error Description	Uncertainty value \pm	Probability distribution	divisor	(ci) lg	Standard (lg)	vi or v _{eff}
Measurement System						
Probe calibration	± 6.55	Normal	1	1	± 6.55	∞
Axial isotropy of the probe	± 4.7	Rectangular	$\sqrt{3}$	1	± 2.7	∞
Spherical isotropy of the probe	± 9.6	Rectangular	$\sqrt{3}$	0	± 0.0	∞
Boundary effects	± 1.0	Rectangular	$\sqrt{3}$	1	± 0.6	∞
Probe linearity	± 4.7	Rectangular	$\sqrt{3}$	1	± 2.7	∞
Detection limit	± 1.0	Rectangular	$\sqrt{3}$	1	± 0.6	∞
Modulation response	± 0.0	Rectangular	$\sqrt{3}$	1	± 0.0	∞
Readout electronics	± 0.3	Normal	1	1	± 0.3	∞
Response time	± 0.0	Rectangular	$\sqrt{3}$	1	± 0.0	∞
Integration time	± 0.0	Rectangular	$\sqrt{3}$	1	± 0.0	∞
RF ambient Noise	± 1.0	Rectangular	$\sqrt{3}$	1	± 0.6	∞
RF ambient Reflections	± 1.0	Rectangular	$\sqrt{3}$	1	± 0.6	∞
Probe Positioner	± 0.8	Rectangular	$\sqrt{3}$	1	± 0.5	∞
Probe positioning	± 6.7	Rectangular	$\sqrt{3}$	1	± 3.9	∞
Max.SAR Eval.	± 2.0	Rectangular	$\sqrt{3}$	1	± 1.2	∞
Dipole Related						
Deviation of exp.dipole	± 5.5	Rectangular	$\sqrt{3}$	1	± 3.2	∞
Dipole Axis to Liquid Distance	± 2.0	Rectangular	$\sqrt{3}$	1	± 1.2	∞
Input power and SAR drift meas.	± 3.4	Rectangular	$\sqrt{3}$	1	± 2.0	∞
Phantom and Setup						
Phantom uncertainty	± 4.0	Rectangular	$\sqrt{3}$	1	± 2.3	∞
Liquid conductivity (target)	± 5.0	Rectangular	$\sqrt{3}$	0.78	± 2.3	∞
Liquid conductivity (meas.)	+ 5.0	Normal	1	0.26	+ 1.3	∞
Liquid permittivity (target)	± 5.0	Rectangular	$\sqrt{3}$	0.78	± 2.3	∞
Liquid permittivity (meas.)	- 5.0	Normal	1	0.23	- 1.2	∞
Liquid conductivity - temp.unc (below 2deg.C.)	± 1.7	Rectangular	$\sqrt{3}$	0.78	± 0.8	∞
Liquid permittivity - temp.unc (below 2deg.C.)	± 0.3	Rectangular	$\sqrt{3}$	0.23	± 0.0	∞
Combined Standard Uncertainty					± 10.491	
Expanded Uncertainty (k=2)					± 21.0	

Note: This uncertainty budget for validation is worst-case.

UL Japan, Inc.

Head Office EMC Lab.

4383-326 Asama-cho, Ise-shi, Mie-ken 516-0021 JAPAN

Telephone: +81 596 24 8116

Facsimile: +81 596 24 8124

2. Specifications

a) Robot TX60L

Number of Axes	:	6
Nominal Load	:	2 kg
Maximum Load	:	5kg
Reach	:	920mm
Repeatability	:	+/-0.03mm
Control Unit	:	CS8c
Programming Language	:	VAL3
Weight	:	52.2kg
Manufacture	:	Stäubli Robotics

b) E-Field Probe

Model	:	EX3DV4
Serial No.	:	3825
Construction	:	Symmetrical design with triangular core Built-in shielding against static charges PEEK enclosure material (resistant to organic solvents, e.g., glycol ether)
Frequency	:	10 MHz to > 6 GHz Linearity: ± 0.2 dB (30 MHz to 6 GHz)
Directivity	:	+/-0.3 dB in HSL (rotation around probe axis) +/-0.5 dB in tissue material (rotation normal probe axis)
Dynamic Range	:	10uW/g to > 100 mW/g; Linearity +/-0.2 dB(noise: typically < 1uW/g)
Dimensions	:	Overall length: 337 mm (Tip: 20 mm) Tip diameter: 2.5mm (Body: 12 mm) Typical distance from probe tip to dipole centers: 1 mm
Application	:	Highprecision dosimetric measurement in any exposure scenario (e.g., very strong gradient fields). Only probe which enables compliance testing for frequencies up to 6GHz with precision of better 30%.
Manufacture	:	Schimid & Partner Engineering AG



EX3DV4 E-field Probe

c) Data Acquisition Electronic (DAE4)

Features	:	Signal amplifier, multiplexer, A/D converter and control logic Serial optical link for communication with DASY5 embedded system (fully remote controlled) Two step probe touch detector for mechanical surface detection and emergency robot stop
Measurement Range	:	-100 to +300 mV (16 bit resolution and two range settings: 4mV, 400mV)
Input Offset voltage	:	< 5 μ V (with auto zero)
Input Resistance	:	200 M Ω
Input Bias Current	:	< 50 fA
Battery Power	:	> 10 h of operation (with two 9.6 V NiMH accus)
Dimension	:	60 x 60 x 68 mm
Manufacture	:	Schimid & Partner Engineering AG

d) Electro-Optic Converter (EOC)

Version	:	EOC 61
Description	:	for TX60 robot arm, including proximity sensor
Manufacture	:	Schimid & Partner Engineering AG

UL Japan, Inc.

Head Office EMC Lab.

4383-326 Asama-cho, Ise-shi, Mie-ken 516-0021 JAPAN

Telephone: +81 596 24 8116

Facsimile: +81 596 24 8124

e)DASY5 Measurement server

Features	:	Intel ULV Celeron 400MHz 128MB chip disk and 128MB RAM 16 Bit A/D converter for surface detection system Vacuum Fluorescent Display Robot Interface Serial link to DAE (with watchdog supervision) Door contact port (Possibility to connect a light curtain) Emergency stop port (to connect the remote control) Signal lamps port Light beam port Three Ethernet connection ports Two USB 2.0 Ports Two serial links Expansion port for future applications
Dimensions (L x W x H)	:	440 x 241 x 89 mm
Manufacture	:	Schimid & Partner Engineering AG

f) Light Beam Switches

Version	:	LB5
Dimensions (L x H)	:	110 x 80 mm
Thickness	:	12 mm
Beam-length	:	80 mm
Manufacture	:	Schimid & Partner Engineering AG

g)Software

Item	:	Dosimetric Assesment System DASY5
Type No.	:	SD 000 401A, SD 000 402A
Software version No.	:	DASY52, Version 52.6 (1)
Manufacture / Origin	:	Schimid & Partner Engineering AG

h)Robot Controll Unit

Weight	:	70 Kg
AC Input Voltage	:	selectable
Manufacturer	:	Stäubli Robotics

i) Phantom and Device Holder

Phantom

Type	:	SAM Twin Phantom V4.0
Description	:	The shell corresponds to the specifications of the Specific Anthropomorphic Mannequin (SAM) phantom defined in IEEE 1528 and IEC 62209-1. It enables the dosimetric evaluation of left and right hand phone usage as well as body mounted usage at the flat phantom region. A cover prevents evaporation of the liquid. Reference markings on the phantom allow the complete setup of all predefined phantom positions and measurement grids by teaching three points with the robot.
Material	:	Vinylester, glass fiber reinforced (VE-GF)
Shell Material	:	Fiberglass
Thickness	:	2.0 +/-0.2 mm
Dimensions	:	Length: 1000 mm Width: 500 mm Height: adjustable feet
Volume	:	Approx. 25 liters
Manufacture	:	Schimid & Partner Engineering AG

Type	:	2mm Flat phantom ERI4.0
Description	:	Phantom for compliance testing of handheld and body-mounted wireless devices in the frequency range of 30 MHz to 6 GHz. ELI4 is fully compatible with the latest draft of the standard IEC 62209 Part II and all known tissue simulating liquids. ELI4 has been optimized regarding its performance and can be integrated into our standard phantom tables. A cover prevents evaporation of the liquid. Reference markings on the phantom allow installation of the complete setup, including all predefined phantom positions and measurement grids, by teaching three points. The phantom is supported by software version DASY4.5 and higher and is compatible with all SPEAG dosimetric probes and dipoles.
Material	:	Vinylester, glass fiber reinforced (VE-GF)
Shell Thickness	:	2.0 ± 0.2 mm (sagging: <1%)
Filling Volume	:	approx. 30 liters
Dimensions	:	Major ellipse axis: 600 mm Minor axis: 400 mm
Manufacture	:	Schimid & Partner Engineering AG

Device Holder

In combination with the Twin SAM Phantom V4.0/V4.0c or ELI4, the Mounting Device enables the rotation of the mounted transmitter device in spherical coordinates. Rotation point is the ear opening point. Transmitter devices can be easily and accurately positioned according to IEC, IEEE, FCC or other specifications. The device holder can be locked for positioning at different phantom sections (left head, right head, flat).

Material : POM

Laptop Extensions kit

Simple but effective and easy-to-use extension for Mounting Device that facilitates the testing of larger devices according to IEC 62209-2 (e.g., laptops, cameras, etc.). It is lightweight and fits easily on the upper part of the Mounting Device in place of the phone positioner. The extension is fully compatible with the Twin-SAM, ELI4 Phantoms.

Material : POM, Acrylic glass, Foam

Urethane

For this measurement, the urethane foam was used as device holder.

UL Japan, Inc.

Head Office EMC Lab.

4383-326 Asama-cho, Ise-shi, Mie-ken 516-0021 JAPAN

Telephone: +81 596 24 8116

Facsimile: +81 596 24 8124

j) Simulated Tissues (Liquid)

The following tissue formulations are provided for reference only as some of the parameters have not been thoroughly verified. The composition of ingredients may be modified accordingly to achieve the desired target tissue parameters required for required for routine SAR evaluation.

Mixture (%)	Frequency (MHz)									
	450		900		1800		1950		2450	
Tissue Type	Head	Body	Head	Body	Head	Body	Head	Body	Head	Body
Water	38.91	46.21	40.29	50.75	55.24	70.17	55.41	69.79	55.0	68.64
Sugar	56.93	51.17	57.90	48.21	-	-	-	-	-	-
Cellulose	0.25	0.18	0.24	0.00	-	-	-	-	-	-
Salt (NaCl)	3.79	2.34	1.39	0.94	0.31	0.39	0.08	0.2	-	-
Preventol	0.12	0.08	0.18	0.10	-	-	-	-	-	-
DGMBE	-	-	-	-	44.45	29.44	44.51	30.0	45.0	31.37
Dielectric Constant	43.42	58.0	42.54	56.1	42.0	56.8	39.9	54.0	39.8	52.5
Conductivity (S/m)	0.85	0.83	0.91	0.95	1.0	1.07	1.42	1.45	1.88	1.78

Note: DGMBE (Diethylenglycol-monobuthyl ether)

Mixture (%)	Frequency (MHz)	
	5800	
Tissue Type	Head	Body
Water	64.0	78.0
Mineral Oil	18.0	11.0
Emulsifiers	15.0	9.0
Additives and salt	3.0	2.0

Decision on Simulated Tissues of 5GHz band

In the current standards (e.g., IEC62209-2, IEEE P1528, OET 65 Supplement C), the dielectric parameters suggested for head and body tissue simulating liquid are given at 3000MHz and 5800MHz. As an intermediate solution, dielectric parameters for the frequencies between 5000 to 5800 MHz were obtained using linear interpolation.

Therefore the dielectric parameters of 5200MHz, 5300MHz, 5600MHz and 5500MHz (The frequency for the validation) were decided as following.

f (MHz)	Head Tissue		Body Tissue		Reference
	ϵ_r	σ [mho/m]	ϵ_r	σ [mho/m]	
3000	38.5	2.40	52.0	2.73	Standard
5800	35.3	5.27	48.2	6.00	Standard
5000	36.2	4.45	49.3	5.07	Interpolated
5100	36.1	4.55	49.1	5.18	Interpolated
5200	36.0	4.66	49.0	5.30	Interpolated
5300	35.9	4.76	48.9	5.42	Interpolated
5400	35.8	4.86	48.7	5.53	Interpolated
5500	35.6	4.96	48.6	5.65	Interpolated
5600	35.5	5.07	48.5	5.77	Interpolated
5700	35.4	5.17	48.3	5.88	Interpolated

Standard and interpolated dielectric parameters for head and body tissue simulating liquid in the frequency range 3000 to 5800MHz.

UL Japan, Inc.

Head Office EMC Lab.

4383-326 Asama-cho, Ise-shi, Mie-ken 516-0021 JAPAN

Telephone: +81 596 24 8116

Facsimile: +81 596 24 8124

3. Dosimetric E-Field Probe Calibration (EX3DV4, S/N: 3825)

Calibration Laboratory of
Schmid & Partner
Engineering AG
Zeughausstrasse 43, 8004 Zurich, Switzerland



S Schweizerischer Kalibrierdienst
C Service suisse d'étalonnage
S Servizio svizzero di taratura
S Swiss Calibration Service

Accredited by the Swiss Accreditation Service (SAS)
The Swiss Accreditation Service is one of the signatories to the EA
Multilateral Agreement for the recognition of calibration certificates

Accreditation No.: SCS 108

Client **UL Japan (PTT)**

Certificate No: EX3-3825_Dec12

CALIBRATION CERTIFICATE

Object **EX3DV4 - SN:3825**

Calibration procedure(s) **QA CAL-01.v8, QA CAL-14.v3, QA CAL-23.v4, QA CAL-25.v4
Calibration procedure for dosimetric E-field probes**

Calibration date: **December 10, 2012**

This calibration certificate documents the traceability to national standards, which realize the physical units of measurements (SI).
The measurements and the uncertainties with confidence probability are given on the following pages and are part of the certificate.

All calibrations have been conducted in the closed laboratory facility: environment temperature (22 ± 3)°C and humidity < 70%.

Calibration Equipment used (M&TE critical for calibration)

Primary Standards	ID	Cal Date (Certificate No.)	Scheduled Calibration
Power meter E4419B	GB41293874	29-Mar-12 (No. 217-01508)	Apr-13
Power sensor E4412A	MY41498087	29-Mar-12 (No. 217-01508)	Apr-13
Reference 3 dB Attenuator	SN: S5054 (3c)	27-Mar-12 (No. 217-01531)	Apr-13
Reference 20 dB Attenuator	SN: S5086 (20b)	27-Mar-12 (No. 217-01529)	Apr-13
Reference 30 dB Attenuator	SN: S5129 (30b)	27-Mar-12 (No. 217-01532)	Apr-13
Reference Probe ES3DV2	SN: 3013	29-Dec-11 (No. ES3-3013_Dec11)	Dec-12
DAE4	SN: 660	20-Jun-12 (No. DAE4-660_Jun12)	Jun-13
Secondary Standards	ID	Check Date (in house)	Scheduled Check
RF generator HP 8648C	US3642U01700	4-Aug-99 (in house check Apr-11)	In house check: Apr-13
Network Analyzer HP 8753E	US37390585	18-Oct-01 (in house check Oct-12)	In house check: Oct-13

	Name	Function	Signature
Calibrated by:	Jeton Kastrati	Laboratory Technician	
Approved by:	Katja Pokovic	Technical Manager	

Issued: December 11, 2012

This calibration certificate shall not be reproduced except in full without written approval of the laboratory.

**Calibration Laboratory of
Schmid & Partner
Engineering AG**
Zeughausstrasse 43, 8004 Zurich, Switzerland



S Schweizerischer Kalibrierdienst
C Service suisse d'étalonnage
S Servizio svizzero di taratura
S Swiss Calibration Service

Accredited by the Swiss Accreditation Service (SAS)

Accreditation No.: **SCS 108**

The Swiss Accreditation Service is one of the signatories to the EA Multilateral Agreement for the recognition of calibration certificates

Glossary:

TSL	tissue simulating liquid
NORM _{x,y,z}	sensitivity in free space
ConvF	sensitivity in TSL / NORM _{x,y,z}
DCP	diode compression point
CF	crest factor (1/duty_cycle) of the RF signal
A, B, C	modulation dependent linearization parameters
Polarization φ	φ rotation around probe axis
Polarization ϑ	ϑ rotation around an axis that is in the plane normal to probe axis (at measurement center), i.e., $\vartheta = 0$ is normal to probe axis

Calibration is Performed According to the Following Standards:

- IEEE Std 1528-2003, "IEEE Recommended Practice for Determining the Peak Spatial-Averaged Specific Absorption Rate (SAR) in the Human Head from Wireless Communications Devices: Measurement Techniques", December 2003
- IEC 62209-1, "Procedure to measure the Specific Absorption Rate (SAR) for hand-held devices used in close proximity to the ear (frequency range of 300 MHz to 3 GHz)", February 2005

Methods Applied and Interpretation of Parameters:

- NORM_{x,y,z}**: Assessed for E-field polarization $\vartheta = 0$ ($f \leq 900$ MHz in TEM-cell; $f > 1800$ MHz: R22 waveguide). NORM_{x,y,z} are only intermediate values, i.e., the uncertainties of NORM_{x,y,z} does not affect the E²-field uncertainty inside TSL (see below ConvF).
- NORM(f)_{x,y,z}** = NORM_{x,y,z} * frequency_response (see Frequency Response Chart). This linearization is implemented in DASY4 software versions later than 4.2. The uncertainty of the frequency response is included in the stated uncertainty of ConvF.
- DCP_{x,y,z}**: DCP are numerical linearization parameters assessed based on the data of power sweep with CW signal (no uncertainty required). DCP does not depend on frequency nor media.
- PAR**: PAR is the Peak to Average Ratio that is not calibrated but determined based on the signal characteristics
- A_{x,y,z}; B_{x,y,z}; C_{x,y,z}; VR_{x,y,z}**: A, B, C are numerical linearization parameters assessed based on the data of power sweep for specific modulation signal. The parameters do not depend on frequency nor media. VR is the maximum calibration range expressed in RMS voltage across the diode.
- ConvF and Boundary Effect Parameters**: Assessed in flat phantom using E-field (or Temperature Transfer Standard for $f \leq 800$ MHz) and inside waveguide using analytical field distributions based on power measurements for $f > 800$ MHz. The same setups are used for assessment of the parameters applied for boundary compensation (alpha, depth) of which typical uncertainty values are given. These parameters are used in DASY4 software to improve probe accuracy close to the boundary. The sensitivity in TSL corresponds to NORM_{x,y,z} * ConvF whereby the uncertainty corresponds to that given for ConvF. A frequency dependent ConvF is used in DASY version 4.4 and higher which allows extending the validity from ± 50 MHz to ± 100 MHz.
- Spherical isotropy (3D deviation from isotropy)**: in a field of low gradients realized using a flat phantom exposed by a patch antenna.
- Sensor Offset**: The sensor offset corresponds to the offset of virtual measurement center from the probe tip (on probe axis). No tolerance required.

UL Japan, Inc.

Head Office EMC Lab.

4383-326 Asama-cho, Ise-shi, Mie-ken 516-0021 JAPAN

Telephone: +81 596 24 8116

Facsimile: +81 596 24 8124

EX3DV4 – SN:3825

December 10, 2012

Probe EX3DV4

SN:3825

Manufactured: September 6, 2011
Calibrated: December 10, 2012

Calibrated for DASY/EASY Systems
(Note: non-compatible with DASY2 system!)

EX3DV4- SN:3825

December 16, 2011

DASY/EASY - Parameters of Probe: EX3DV4 - SN:3825**Basic Calibration Parameters**

	Sensor X	Sensor Y	Sensor Z	Unc (k=2)
Norm ($\mu\text{V}/(\text{V}/\text{m})^2$) ^A	0.43	0.39	0.43	± 10.1 %
DCP (mV) ^B	100.7	103.5	99.4	

Modulation Calibration Parameters

UID	Communication System Name	PAR		A dB	B dB	C dB	VR mV	Unc ^E (k=2)
10000	CW	0.00	X	0.00	0.00	1.00	144.3	±3.0 %
			Y	0.00	0.00	1.00	133.8	
			Z	0.00	0.00	1.00	109.4	

The reported uncertainty of measurement is stated as the standard uncertainty of measurement multiplied by the coverage factor k=2, which for a normal distribution corresponds to a coverage probability of approximately 95%.

^A The uncertainties of NormX,Y,Z do not affect the E²-field uncertainty inside TSL (see Pages 5 and 6).

^B Numerical linearization parameter: uncertainty not required.

^E Uncertainty is determined using the max. deviation from linear response applying rectangular distribution and is expressed for the square of the field value.

DASY/EASY - Parameters of Probe: EX3DV4 - SN:3825

Calibration Parameter Determined in Head Tissue Simulating Media

f (MHz) ^C	Relative Permittivity ^F	Conductivity (S/m) ^F	ConvF X	ConvF Y	ConvF Z	Alpha	Depth (mm)	Unct. (k=2)
750	41.9	0.89	9.80	9.80	9.80	0.13	1.55	± 12.0 %
835	41.5	0.90	9.39	9.39	9.39	0.16	1.39	± 12.0 %
900	41.5	0.97	9.22	9.22	9.22	0.15	1.32	± 12.0 %
1750	40.1	1.37	8.85	8.85	8.85	0.18	1.36	± 12.0 %
1810	40.0	1.40	8.55	8.55	8.55	0.13	1.77	± 12.0 %
1900	40.0	1.40	8.43	8.43	8.43	0.17	1.23	± 12.0 %
2000	40.0	1.40	8.27	8.27	8.27	0.43	0.79	± 12.0 %
2450	39.2	1.80	7.44	7.44	7.44	0.24	1.23	± 12.0 %
2600	39.0	1.96	7.21	7.21	7.21	0.29	0.95	± 12.0 %
5200	36.0	4.66	5.35	5.35	5.35	0.30	1.80	± 13.1 %
5300	35.9	4.76	5.06	5.06	5.06	0.35	1.80	± 13.1 %
5500	35.6	4.96	4.68	4.68	4.68	0.42	1.80	± 13.1 %
5600	35.5	5.07	4.38	4.38	4.38	0.45	1.80	± 13.1 %
5800	35.3	5.27	4.48	4.48	4.48	0.45	1.80	± 13.1 %

^C Frequency validity of ± 100 MHz only applies for DASY v4.4 and higher (see Page 2), else it is restricted to ± 50 MHz. The uncertainty is the RSS of the ConvF uncertainty at calibration frequency and the uncertainty for the indicated frequency band.

^F At frequencies below 3 GHz, the validity of tissue parameters (ϵ and σ) can be relaxed to ± 10% if liquid compensation formula is applied to measured SAR values. At frequencies above 3 GHz, the validity of tissue parameters (ϵ and σ) is restricted to ± 5%. The uncertainty is the RSS of the ConvF uncertainty for indicated target tissue parameters.

UL Japan, Inc.

Head Office EMC Lab.

4383-326 Asama-cho, Ise-shi, Mie-ken 516-0021 JAPAN

Telephone: +81 596 24 8116

Facsimile: +81 596 24 8124

DASY/EASY - Parameters of Probe: EX3DV4 - SN:3825

Calibration Parameter Determined in Body Tissue Simulating Media

f (MHz) ^C	Relative Permittivity ^F	Conductivity (S/m) ^F	ConvF X	ConvF Y	ConvF Z	Alpha	Depth (mm)	Unct. (k=2)
750	55.5	0.96	9.77	9.77	9.77	0.26	1.05	± 12.0 %
835	55.2	0.97	9.61	9.61	9.61	0.24	1.13	± 12.0 %
900	55.0	1.05	9.42	9.42	9.42	0.20	1.30	± 12.0 %
1750	53.4	1.49	7.87	7.87	7.87	0.10	2.72	± 12.0 %
1810	53.3	1.52	7.69	7.69	7.69	0.11	2.21	± 12.0 %
1900	53.3	1.52	7.48	7.48	7.48	0.10	1.76	± 12.0 %
2000	53.3	1.52	7.64	7.64	7.64	0.21	1.11	± 12.0 %
2450	52.7	1.95	7.23	7.23	7.23	0.78	0.50	± 12.0 %
2600	52.5	2.16	7.14	7.14	7.14	0.80	0.50	± 12.0 %
5200	49.0	5.30	4.45	4.45	4.45	0.50	1.90	± 13.1 %
5300	48.9	5.42	4.22	4.22	4.22	0.50	1.90	± 13.1 %
5500	48.6	5.65	3.76	3.76	3.76	0.55	1.90	± 13.1 %
5600	48.5	5.77	3.59	3.59	3.59	0.60	1.90	± 13.1 %
5800	48.2	6.00	4.07	4.07	4.07	0.55	1.90	± 13.1 %

^C Frequency validity of ± 100 MHz only applies for DASY v4.4 and higher (see Page 2), else it is restricted to ± 50 MHz. The uncertainty is the RSS of the ConvF uncertainty at calibration frequency and the uncertainty for the indicated frequency band.

^F At frequencies below 3 GHz, the validity of tissue parameters (ϵ and σ) can be relaxed to ± 10% if liquid compensation formula is applied to measured SAR values. At frequencies above 3 GHz, the validity of tissue parameters (ϵ and σ) is restricted to ± 5%. The uncertainty is the RSS of the ConvF uncertainty for indicated target tissue parameters.

EX3DV4--SN:3825

December 16, 2011

Frequency Response of E-Field (TEM-Cell:ifi110 EXX, Waveguide: R22)

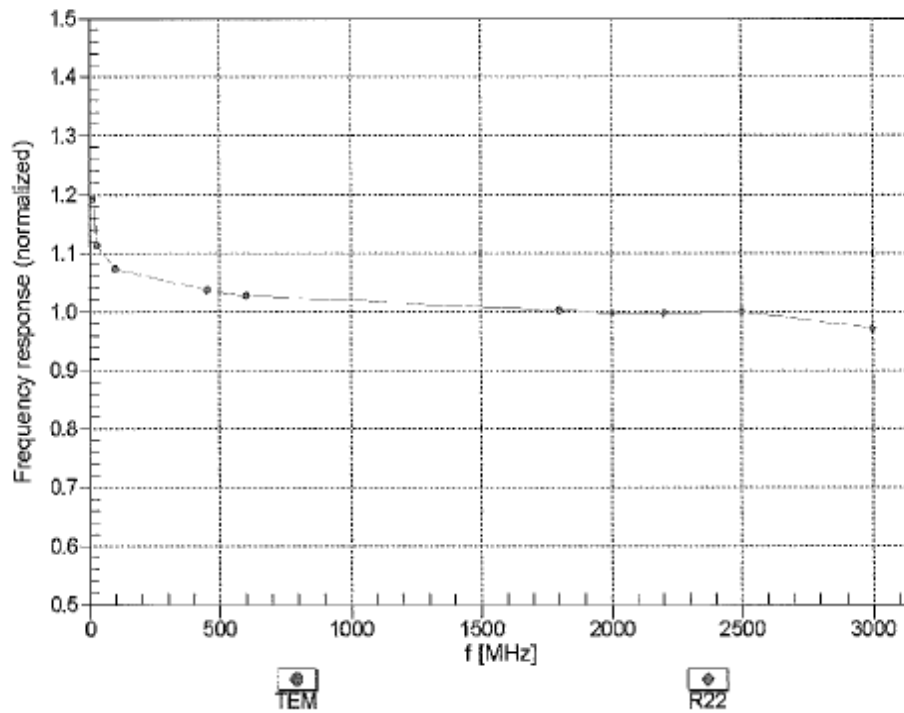

Uncertainty of Frequency Response of E-field: $\pm 6.3\%$ (k=2)

EX3DV4- SN:3825

December 16, 2011

Receiving Pattern (ϕ), $\vartheta = 0^\circ$

f=600 MHz,TEM

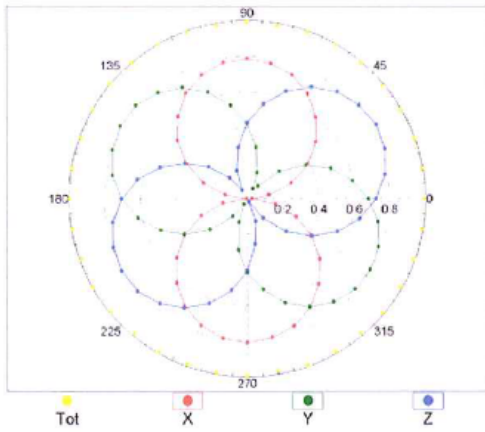

f=1800 MHz,R22

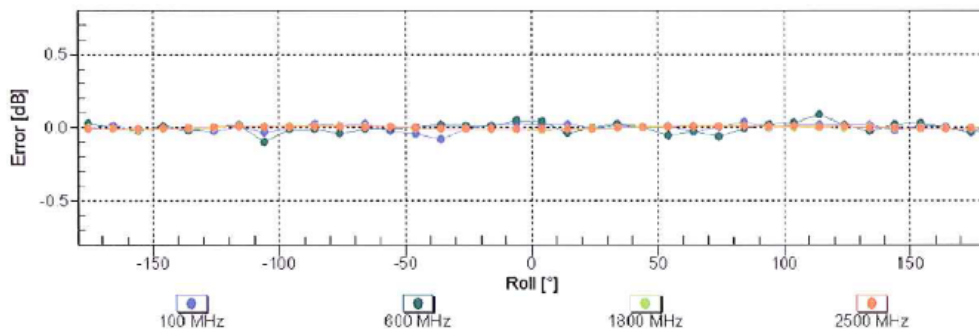
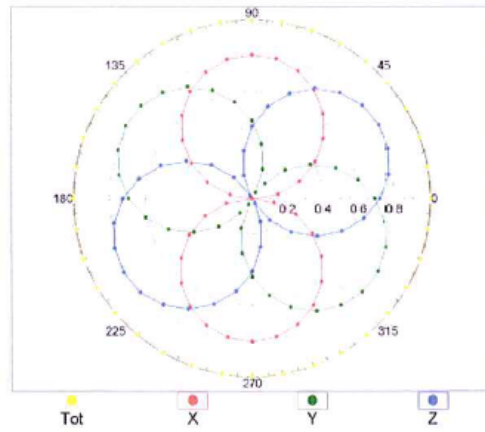

Uncertainty of Axial Isotropy Assessment: $\pm 0.5\%$ (k=2)

EX3DV4-SN:3825

December 16, 2011

Dynamic Range f(SAR_{head}) (TEM cell , f = 900 MHz)

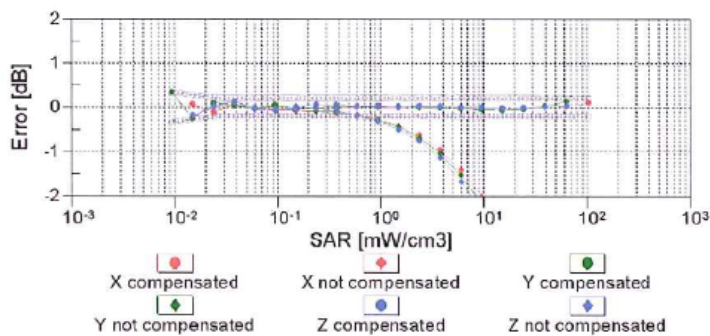
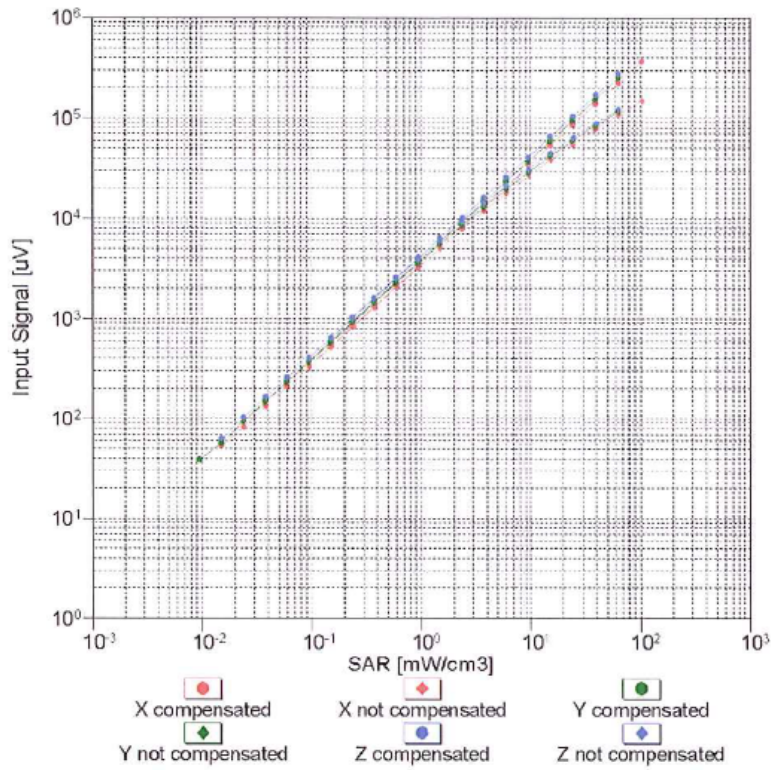

Uncertainty of Linearity Assessment: ± 0.6% (k=2)

EX3DV4-SN:3825

December 16, 2011

Conversion Factor Assessment

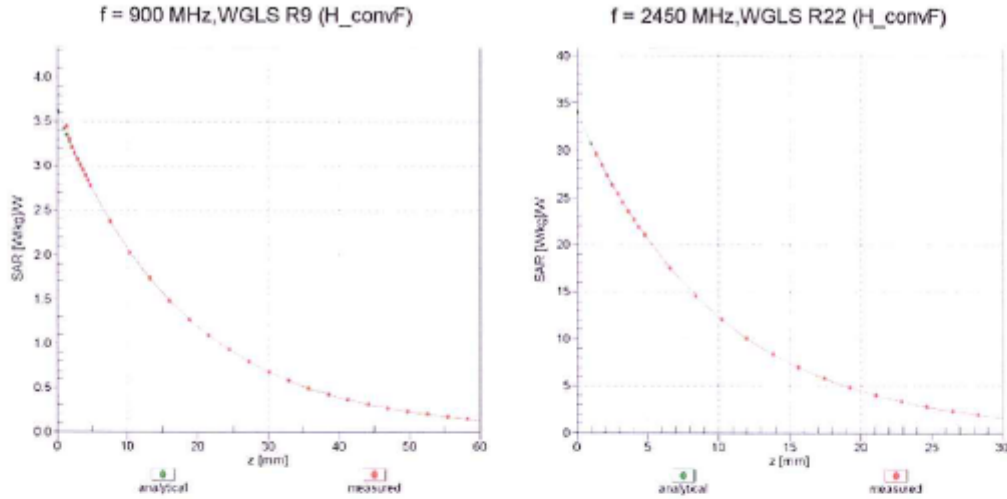

Deviation from Isotropy in Liquid

Error (ϕ , ϑ), f = 900 MHz

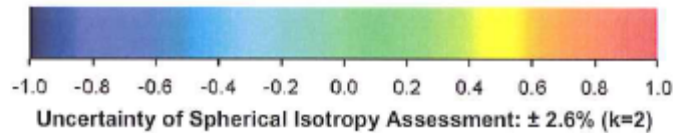
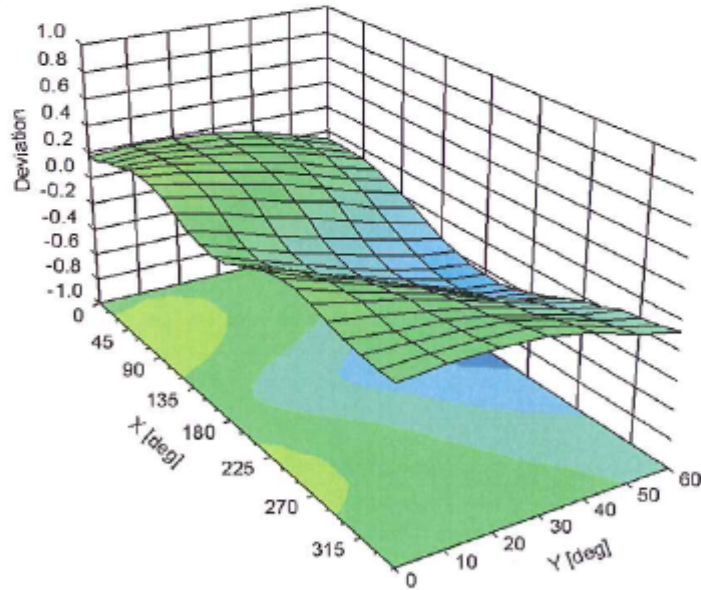

EX3DV4-SN:3825

December 16, 2011

DASY/EASY - Parameters of Probe: EX3DV4 - SN:3825

Other Probe Parameters

Sensor Arrangement	Triangular
Connector Angle (°)	Not applicable
Mechanical Surface Detection Mode	enabled
Optical Surface Detection Mode	disabled
Probe Overall Length	337 mm
Probe Body Diameter	10 mm
Tip Length	9 mm
Tip Diameter	2.5 mm
Probe Tip to Sensor X Calibration Point	1 mm
Probe Tip to Sensor Y Calibration Point	1 mm
Probe Tip to Sensor Z Calibration Point	1 mm
Recommended Measurement Distance from Surface	2 mm

UL Japan, Inc.

Head Office EMC Lab.

4383-326 Asama-cho, Ise-shi, Mie-ken 516-0021 JAPAN

Telephone: +81 596 24 8116

Facsimile: +81 596 24 8124