

## FCC Test Report

**Report No.:** RFBVSW-WTW-P20110319B

**FCC ID:** W23-WMU62XX

**Test Model:** WMU6202

**Series Model:** WMU6203, WMU6204, WMU6205 (Refer to item 3.1 for more details)

**Received Date:** Dec. 05, 2022

**Test Date:** Dec. 23 ~ Dec. 30, 2022

**Issued Date:** Jan. 30, 2023

**Applicant:** jjPlus Corporation

**Address:** 15F-7, No.2, Jianba Road. Zhonghe Dist., New Taipei City 235, Taiwan  
(R.O.C.)

**Issued By:** Bureau Veritas Consumer Products Services (H.K.) Ltd., Taoyuan Branch  
Lin Kou Laboratories

**Lab Address:** No. 47-2, 14th Ling, Chia Pau Vil., Lin Kou Dist., New Taipei City, Taiwan

**Test Location (1):** No.19, Hwa Ya 2nd Rd., Wen Hwa Vil., Kwei Shan Dist., Taoyuan City  
33383, Taiwan

**Test Location (2):** No. 70, Wenming Rd., Guishan Dist., Taoyuan City 333, Taiwan

**FCC Registration /  
Designation Number (1):** 788550 / TW0003

**FCC Registration /  
Designation Number(2):** 281270 / TW0032



This report is governed by, and incorporates by reference, the Conditions of Testing as posted at the date of issuance of this report at <http://www.bureauveritas.com/home/about-us/our-business/cps/about-us/terms-conditions/> and is intended for your exclusive use. Any copying or replication of this report to or for any other person or entity, or use of our name or trademark, is permitted only with our prior written permission. This report sets forth our findings solely with respect to the test samples identified herein. The results set forth in this report are not indicative or representative of the quality or characteristics of the lot from which a test sample was taken or any similar or identical product unless specifically and expressly noted. Our report includes all of the tests requested by you and the results thereof based upon the information that you provided to us. Measurement uncertainty is only provided upon request for accredited tests. Statements of conformity are based on simple acceptance criteria without taking measurement uncertainty into account, unless otherwise requested in writing. You have 60 days from date of issuance of this report to notify us of any material error or omission caused by our negligence or if you require measurement uncertainty; provided, however, that such notice shall be in writing and shall specifically address the issue you wish to raise. A failure to raise such issue within the prescribed time shall constitute your unqualified acceptance of the completeness of this report, the tests conducted and the correctness of the report contents.

## Table of Contents

<b>Release Control Record .....</b>	<b>3</b>
<b>1 Certificate of Conformity .....</b>	<b>4</b>
<b>2 Summary of Test Results.....</b>	<b>5</b>
2.1 Measurement Uncertainty.....	5
2.2 Modification Record .....	5
<b>3 General Information .....</b>	<b>6</b>
3.1 General Description of EUT .....	6
3.2 Description of Test Modes.....	7
3.2.1 Test Mode Applicability and Tested Channel Detail .....	8
3.3 Duty Cycle of Test Signal .....	8
3.4 Description of Support Units .....	9
3.4.1 Configuration of System under Test .....	9
3.5 General Description of Applied Standards and References .....	9
<b>4 Test Types and Results .....</b>	<b>10</b>
4.1 Radiated Emission and Bandedge Measurement .....	10
4.1.1 Limits of Radiated Emission and Bandedge Measurement .....	10
4.1.2 Test Instruments .....	11
4.1.3 Test Procedures.....	12
4.1.4 Deviation from Test Standard .....	12
4.1.5 Test Set Up .....	13
4.1.6 EUT Operating Conditions.....	14
4.1.7 Test Results .....	15
<b>5 Pictures of Test Arrangements.....</b>	<b>18</b>
<b>Annex A- Band Edge Measurement .....</b>	<b>19</b>
<b>Appendix – Information of the Testing Laboratories .....</b>	<b>20</b>

### Release Control Record

Issue No.	Description	Date Issued
RFBVSW-WTW-P20110319B	Original Release	Jan. 30, 2023

## 1 Certificate of Conformity

**Product:** 11ac 2T2R WIFI & BT Module

**Brand:** jjPlus

**Test Model:** WMU6202

**Series Model:** WMU6203, WMU6204, WMU6205 (Refer to item 3.1 for more details)

**Sample Status:** Engineering Sample

**Applicant:** jjPlus Corporation

**Test Date:** Dec. 23 ~ Dec. 30, 2022

**Standards:** 47 CFR FCC Part 15, Subpart C (Section 15.247)  
ANSI C63.10:2013

This report is issued as a supplementary report to BV CPS report no.: RFBAYS-WTW-P20110319A. This report shall be used by combining with its original report.

**Prepared by :** Gina Liu, **Date:** Jan. 30, 2023  
Gina Liu / Specialist

**Approved by :** Jeremy Lin, **Date:** Jan. 30, 2023  
Jeremy Lin / Project Engineer

## 2 Summary of Test Results

47 CFR FCC Part 15, Subpart C (Section 15.247)			
FCC Clause	Test Item	Result	Remarks
15.207	AC Power Conducted Emission	N/A	Refer to Note
15.247(a)(1)(iii)	Number of Hopping Frequency Used	N/A	Refer to Note
15.247(a)(1)(iii)	Dwell Time on Each Channel	N/A	Refer to Note
15.247(a)(1)	1. Hopping Channel Separation 2. Spectrum Bandwidth of a Frequency Hopping Sequence Spread Spectrum System	N/A	Refer to Note
15.247(a)(1)	Maximum Peak Output Power	N/A	Refer to Note
---	Occupied Bandwidth Measurement	N/A	Refer to Note
15.205 & 209	Radiated Emissions	Pass	Meet the requirement of limit. Minimum passing margin is -2.1 dB at 238.55 MHz.
15.247(d)	Band Edge Measurement	N/A	Refer to Note
15.247(d)	Antenna Port Emission	N/A	Refer to Note
15.203	Antenna Requirement	Pass	Antenna connector is U.FLx2 not a standard connector.

### Note:

1. Only Radiated Emissions test was performed for this addendum. Refer to original report for other test data.
2. For 2.4G band compliance with rule 15.247(d) of the band-edge items, the test plots were recorded in Annex A. Test Procedures refer to report 4.1.3.
3. Determining compliance based on the results of the compliance measurement, not taking into account measurement instrumentation uncertainty.

### 2.1 Measurement Uncertainty

Where relevant, the following measurement uncertainty levels have been estimated for tests performed on the EUT as specified in CISPR 16-4-2:

Measurement	Frequency	Expanded Uncertainty (k=2) (±)
Radiated Emissions up to 1 GHz	9kHz ~ 30MHz	3.00 dB
	30MHz ~ 200MHz	2.91 dB
	200MHz ~ 1000MHz	2.93 dB
Radiated Emissions above 1 GHz	1GHz ~ 18GHz	1.76 dB
	18GHz ~ 40GHz	1.77 dB

### 2.2 Modification Record

There were no modifications required for compliance.

### 3 General Information

#### 3.1 General Description of EUT

<b>Product</b>	11ac 2T2R WIFI & BT Module
<b>Brand</b>	jjPlus
<b>Test Model</b>	WMU6202
<b>Series Model</b>	WMU6203, WMU6204, WMU6205
<b>Status of EUT</b>	Engineering Sample
<b>Power Supply Rating</b>	3.3 Vdc (host equipment)
<b>Modulation Type</b>	GFSK, $\pi/4$ -DQPSK, 8DPSK
<b>Transfer Rate</b>	1/2/3 Mbps
<b>Operating Frequency</b>	2402 ~ 2480 MHz
<b>Number of Channel</b>	79
<b>Antenna Type</b>	Refer to Note
<b>Antenna Connector</b>	Refer to Note
<b>Accessory Device</b>	N/A
<b>Data Cable Supplied</b>	N/A

Note:

1. This report is prepared for FCC class II permissive change. This report is issued as a supplementary report to BV CPS report no. RFBAYS-WTW-P20110319A. The difference compared with original report is adding new Antennas. Therefore, only Radiated Emissions test re-test and recorded in this report.
2. All models and antennas are listed as below.

Test Mode	Model	RF Chip	RF Design	Interface	Antenna type	Antenna connector
v	WMU6202	RTL8822BU	The Same	mPCIe	Dipole PIFA	U.FLx2
	WMU6203			M.2		MHF4
	WMU6204			USB Type-A		U.FLx2
	WMU6205			4Pin Wafer		U.FLx2

\*The difference Models are pre-tested, because the connector and interface are difference with difference Model, and selected the worst Model for testing.

3. The antennas information is listed as below. (New antenna is marked in boldface.)

Antenna Type	Brand	Model	Antenna Gain (dBi)			Antenna Connector
			BT	2.4G	5G	
Dipole	LYNwave	AOA160-221020-000000	3.0	3.0	2.0	ipex(MHF)
	LYNwave	AOA160-221034-000000	3.0	3.0	3.0	ipex(MHF)
	LYNwave	AOA160-221050-000000	5.0	5.0	5.0	ipex(MHF)
PIFA	SINBON	A9706632	4.1	4.1	3.5	MHFI
	SINBON	A9706633	4.8	4.8	4.1	MHFI
Dipole	<b>ARISTOTLE</b>	<b>RFA-25-AP152R-70-180</b>	<b>3.42</b>	<b>3.42</b>	<b>4.33</b>	<b>ipex(MHF)</b>
	<b>ARISTOTLE</b>	<b>RFA-25-AP152R-70B360</b>	<b>2.55</b>	<b>2.55</b>	<b>2.34</b>	<b>ipex(MHF)</b>

4. Detail antenna specification please refer to antenna datasheet and/or antenna measurement report.
5. The above EUT information is declared by manufacturer and for more detailed features description, please refers to the manufacturer's specifications or User's Manual.

### 3.2 Description of Test Modes

79 channels are provided to this EUT:

Channel	Freq. (MHz)	Channel	Freq. (MHz)	Channel	Freq. (MHz)	Channel	Freq. (MHz)
0	2402	20	2422	40	2442	60	2462
1	2403	21	2423	41	2443	61	2463
2	2404	22	2424	42	2444	62	2464
3	2405	23	2425	43	2445	63	2465
4	2406	24	2426	44	2446	64	2466
5	2407	25	2427	45	2447	65	2467
6	2408	26	2428	46	2448	66	2468
7	2409	27	2429	47	2449	67	2469
8	2410	28	2430	48	2450	68	2470
9	2411	29	2431	49	2451	69	2471
10	2412	30	2432	50	2452	70	2472
11	2413	31	2433	51	2453	71	2473
12	2414	32	2434	52	2454	72	2474
13	2415	33	2435	53	2455	73	2475
14	2416	34	2436	54	2456	74	2476
15	2417	35	2437	55	2457	75	2477
16	2418	36	2438	56	2458	76	2478
17	2419	37	2439	57	2459	77	2479
18	2420	38	2440	58	2460	78	2480
19	2421	39	2441	59	2461		

### 3.2.1 Test Mode Applicability and Tested Channel Detail

EUT Configure Mode	Applicable To		Description
	RE $\geq$ 1G	RE<1G	
-	√	√	-

Where **RE $\geq$ 1G**: Radiated Emission above 1 GHz      **RE<1G**: Radiated Emission below 1 GHz

**Note:**

- The EUT had been pre-tested on the positioned of each 3 axis. The worst case was found when positioned on Z-plane.
- "-" means no effect.

#### **Radiated Emission Test (Above 1 GHz):**

- Pre-Scan has been conducted to determine the worst-case mode from all possible combinations between available modulations, data rates and antenna ports (if EUT with antenna diversity architecture).
- Following channel(s) was (were) selected for the final test as listed below.

EUT Configure Mode	Available Channel	Tested Channel	Modulation Technology	Modulation Type	Packet Type
-	0 to 78	78	FHSS	8DPSK	3DH5

#### **Radiated Emission Test (Below 1 GHz):**

- Pre-Scan has been conducted to determine the worst-case mode from all possible combinations between available modulations, data rates and antenna ports (if EUT with antenna diversity architecture).
- Following channel(s) was (were) selected for the final test as listed below.

EUT Configure Mode	Available Channel	Tested Channel	Modulation Technology	Modulation Type	Packet Type
-	0 to 78	78	FHSS	8DPSK	3DH5

#### **Test Condition:**

Applicable To	Environmental Conditions	Input Power	Tested by
RE $\geq$ 1G	20 deg. C, 71 % RH	120 Vac, 60 Hz	Noah Chang
RE<1G	20 deg. C, 71 % RH	120 Vac, 60 Hz	Noah Chang

### 3.3 Duty Cycle of Test Signal

Duty cycle =  $3/100 = 0.030$ , duty cycle correction factor =  $20 \cdot \log(0.030) = -30.5$

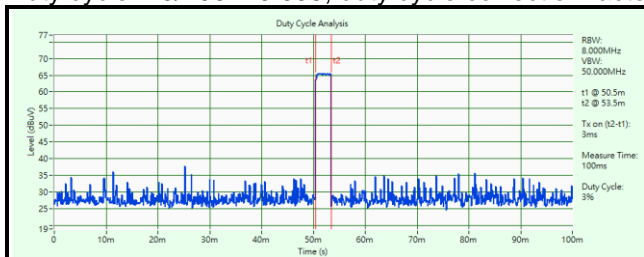



### 3.4 Description of Support Units

The EUT has been tested as an independent unit together with other necessary accessories or support units. The following support units or accessories were used to form a representative test configuration during the tests.

No.	Product	Brand	Model No.	Serial No.	FCC ID	Remarks
A.	Notebook	DELL	E6420	D3T96R1	N/A	Provided by Lab
B.	Test fixture	N/A	N/A	N/A	N/A	Provided by Client

#### 3.4.1 Configuration of System under Test

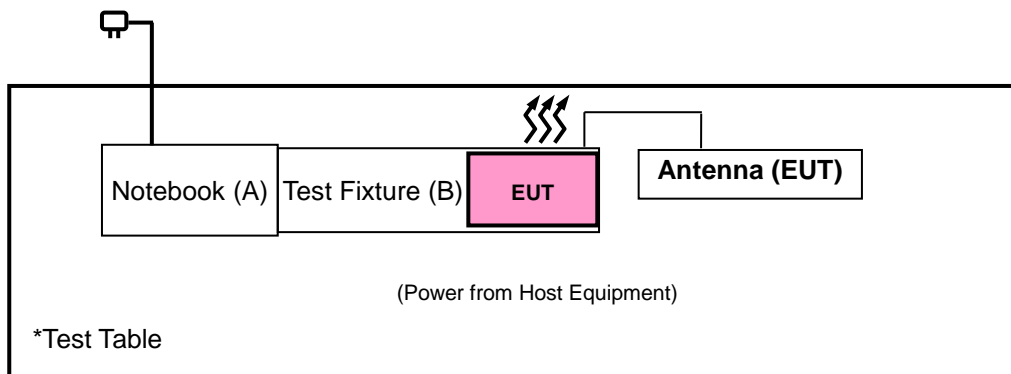

### 3.5 General Description of Applied Standards and References

The EUT is a RF Product. According to the specifications of the manufacturer, it must comply with the requirements of the following standards and references:

#### Test Standard:

#### FCC Part 15, Subpart C (15.247)

ANSI C63.10-2013

All test items have been performed and recorded as per the above standards.

#### References Test Guidance:

#### KDB 558074 D01 15.247 Meas Guidance v05r02

All test items have been performed as a reference to the above KDB test guidance.

## 4 Test Types and Results

### 4.1 Radiated Emission and Bandedge Measurement

#### 4.1.1 Limits of Radiated Emission and Bandedge Measurement

Radiated emissions which fall in the restricted bands must comply with the radiated emission limits specified as below table. Other emissions shall be at least 20 dB below the highest level of the desired power:

Frequencies (MHz)	Field Strength (microvolts/meter)	Measurement Distance (meters)
0.009 ~ 0.490	2400/F (kHz)	300
0.490 ~ 1.705	24000/F (kHz)	30
1.705 ~ 30.0	30	30
30 ~ 88	100	3
88 ~ 216	150	3
216 ~ 960	200	3
Above 960	500	3

**Note:**

- a. The lower limit shall apply at the transition frequencies.
- b. Emission level (dBuV/m) = 20 log Emission level (uV/m).
- c. For frequencies above 1000 MHz, the field strength limits are based on average detector, however, the peak field strength of any emission shall not exceed the maximum permitted average limits, specified above by more than 20 dB under any condition of modulation.

#### 4.1.2 Test Instruments

Description & Manufacturer	Model No.	Serial No.	Cal. Date	Cal. Due
Test Receiver KEYSIGHT	N9038B	MY60180018	Feb. 18, 2022	Feb. 17, 2023
Spectrum Analyzer KEYSIGHT	N9020B	MY60110513	Dec. 24, 2021	Dec. 23, 2022
			Dec. 26, 2022	Dec. 25, 2023
BILOG Antenna SCHWARZBECK	VULB9168	9168-1214	Oct. 20, 2022	Oct. 19, 2023
HORN Antenna RF SPIN	DRH18-E	210101A18E	Nov. 13, 2022	Nov. 12, 2023
HORN Antenna SCHWARZBECK	BBHA 9170	9170-1048	Nov. 13, 2022	Nov. 12, 2023
Loop Antenna TESEQ	HLA 6121	45745	Jul. 27, 2022	Jul. 26, 2023
Preamplifier EMCI	EMC330N	980798	Jan. 17, 2022	Jan. 16, 2023
Preamplifier EMCI	EMC118A45SE	980808	Dec. 30, 2021	Dec. 29, 2022
			Dec. 29, 2022	Dec. 28, 2023
Preamplifier EMCI	EMC184045SE	980786	Jan. 17, 2022	Jan. 16, 2023
RF signal cable EMCI	EMC104-SM-SM-(9000+3000+1000)	201244+ 201232+ 210103	Jan. 17, 2022	Jan. 16, 2023
RF signal cable EMCI	EMCCFD400-NM-NM-(9000+300+500)	201251+ 201249+ 201248	Jan. 17, 2022	Jan. 16, 2023
RF signal cable EMCI	EMC101G-KM-KM-(5000+3000+2000)	201261+201258+ 201255	Jan. 17, 2022	Jan. 16, 2023
Software BV ADT	ADT_Radiated_V7.6.15.9.5	NA	NA	NA
Antenna Tower Max-Full	MFA-515BSN	NA	NA	NA
Turn Table Max-Full	MFT-201SS	NA	NA	NA
Turn Table Controller Max-Full	MF-7802BS	MF780208676	NA	NA
Radio Communication Analyzer Anritsu	MT8821C	6201462755	Mar. 03, 2022	Mar. 02, 2023
DC power supply Keysight	U8002A	MY56330015	NA	NA
Digital Multimeter Fluke	87-III	70360742	Jun. 23, 2022	Jun. 22, 2023
Spectrum Analyzer KEYSIGHT	N9030B	MY57140953	Jul. 01, 2022	Jun. 30, 2023
Temperature & Humidity Chamber TERCHY	HRM-120RF	931022	Jan. 03, 2022	Jan. 02, 2023

Note: 1. The calibration interval of the above test instruments is 12 months and the calibrations are traceable to NML/ROC and NIST/USA.

2. The test was performed in WM Chamber 9.

#### 4.1.3 Test Procedures

##### **For Radiated Emission below 30 MHz**

- a. The EUT was placed on the top of a rotating table 0.8 meters above the ground at a 3 meter chamber room. The table was rotated 360 degrees to determine the position of the highest radiation.
- b. The EUT was set 3 meters away from the interference-receiving antenna, which was mounted on the top of a variable-height antenna tower.
- c. Parallel, perpendicular, and ground-parallel orientations of the antenna are set to make the measurement.
- d. For each suspected emission, the EUT was arranged to its worst case and the rotatable table was turned from 0 degrees to 360 degrees to find the maximum reading.
- e. The test-receiver system was set to Quasi-Peak Detect Function and Specified Bandwidth with Maximum Hold Mode.

##### **Note:**

1. The resolution bandwidth and video bandwidth of test receiver/spectrum analyzer is 9 kHz at frequency below 30 MHz.

##### **For Radiated Emission above 30 MHz**

- a. The EUT was placed on the top of a rotating table 0.8 meters (for 30 MHz ~ 1 GHz) / 1.5 meters (for above 1 GHz) above the ground at 3 meter chamber room for test. The table was rotated 360 degrees to determine the position of the highest radiation.
- b. The EUT was set 3 meters away from the interference-receiving antenna, which was mounted on the top of a variable-height antenna tower.
- c. The height of antenna is varied from one meter to four meters above the ground to determine the maximum value of the field strength. Both horizontal and vertical polarizations of the antenna are set to make the measurement.
- d. For each suspected emission, the EUT was arranged to its worst case and then the antenna was tuned to heights from 1 meter to 4 meters and the rotatable table was turned from 0 degrees to 360 degrees to find the maximum reading.
- e. The test-receiver system was set to quasi-peak detect function and specified bandwidth with maximum hold mode when the test frequency is below 1 GHz.
- f. The test-receiver system was set to peak and average detected function and specified bandwidth with maximum hold mode when the test frequency is above 1 GHz. If the peak reading value also meets average limit, measurement with the average detector is unnecessary.

##### **Note:**

1. The resolution bandwidth and video bandwidth of test receiver/spectrum analyzer is 120 kHz for Quasi-peak detection (QP) or Peak detection (PK) at frequency below 1 GHz.
2. The resolution bandwidth of test receiver/spectrum analyzer is 1 MHz and the video bandwidth is 3 MHz for Peak detection (PK) at frequency above 1 GHz.
3. For BT: Fundamental frequency and band edge & harmonic:  
The average value of fundamental frequency is :average value = peak value + 20\*log(Duty cycle) where the duty cycle correction factor is calculated from following formula:  
 $20 \cdot \log(\text{Duty cycle}) = 20 \cdot \log(0.030) = -30.5 \text{ dB}$ , please refer to the plotted duty (see section 3.3)
4. All modes of operation were investigated and the worst-case emissions are reported.

#### 4.1.4 Deviation from Test Standard

No deviation.

4.1.5 Test Set Up

<Radiated Emission below 30 MHz>

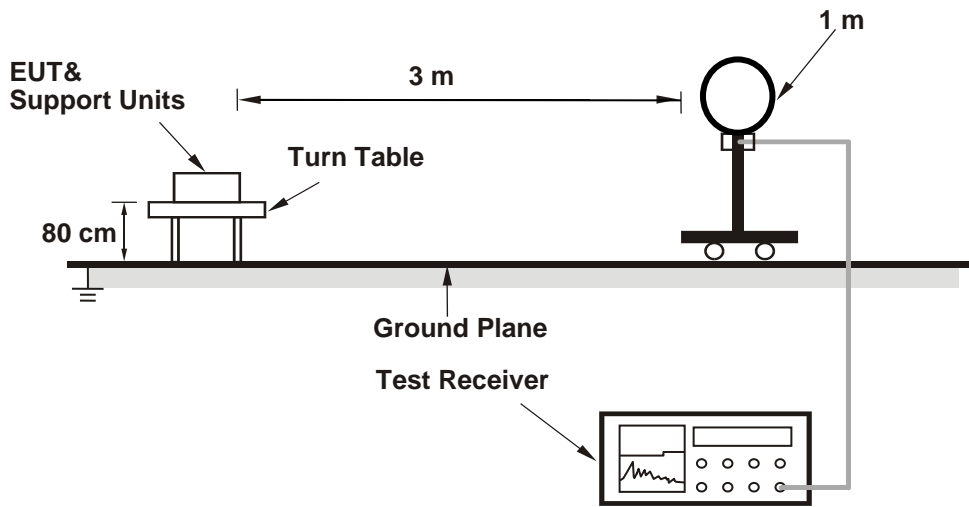

<Radiated Emission 30 MHz to 1 GHz>

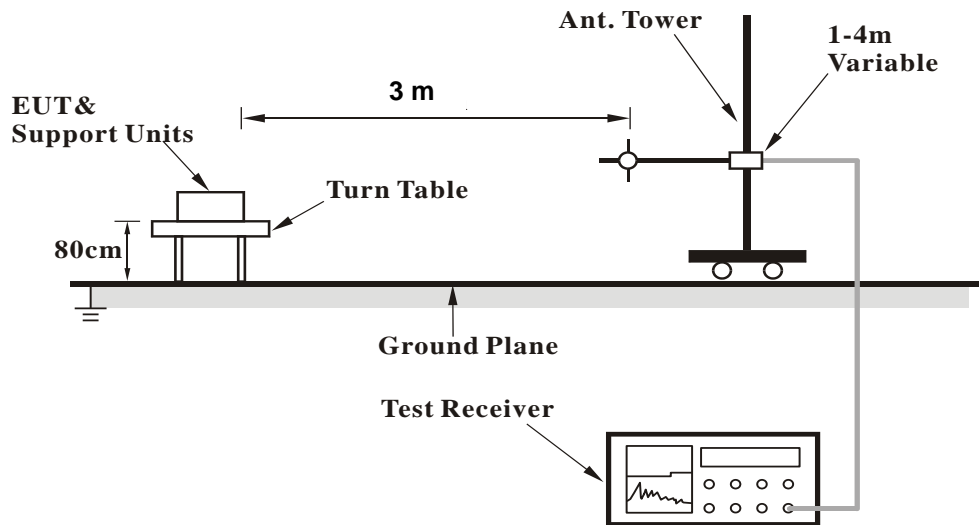

**<Radiated Emission above 1 GHz>**

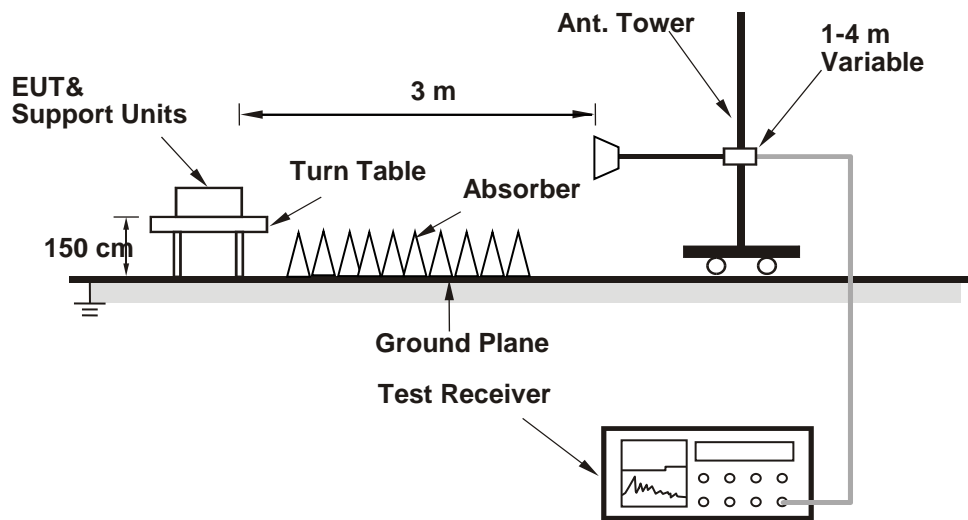

For the actual test configuration, please refer to the attached file (Test Setup Photo).

**4.1.6 EUT Operating Conditions**

Set the EUT under transmission condition continuously at specific channel frequency.

#### 4.1.7 Test Results

#### Above 1 GHz Data: 8DPSK

<b>Channel</b>	CH 78 : 2480 MHz	<b>Frequency Range</b>	1 GHz ~ 25 GHz
<b>Input Power</b>	120 Vac, 60 Hz	<b>Detector Function</b>	Peak (PK) Average (AV)
<b>Environmental Conditions</b>	20°C, 71% RH	<b>Tested By</b>	Noah Chang

#### Antenna Polarity & Test Distance : Horizontal at 3 m

No	Frequency (MHz)	Emission Level (dBuV/m)	Limit (dBuV/m)	Margin (dB)	Antenna Height (m)	Table Angle (Degree)	Raw Value (dBuV)	Correction Factor (dB/m)
1	*2480.00	96.8 PK			1.14 H	149	64.6	32.2
2	*2480.00	66.3 AV			1.14 H	149	34.1	32.2
3	2483.50	50.5 PK	74.0	-23.5	1.14 H	149	55.5	-5.0
4	2483.50	20.0 AV	54.0	-34.0	1.14 H	149	25.0	-5.0
5	4960.00	47.0 PK	74.0	-27.0	2.08 H	331	44.5	2.5
6	4960.00	16.5 AV	54.0	-37.5	2.08 H	331	14.0	2.5

#### Antenna Polarity & Test Distance : Vertical at 3 m

No	Frequency (MHz)	Emission Level (dBuV/m)	Limit (dBuV/m)	Margin (dB)	Antenna Height (m)	Table Angle (Degree)	Raw Value (dBuV)	Correction Factor (dB/m)
1	*2480.00	102.4 PK			1.39 V	245	70.2	32.2
2	*2480.00	71.9 AV			1.39 V	245	39.7	32.2
3	2483.50	40.7 PK	74.0	-33.3	1.39 V	245	45.7	-5.0
4	2483.50	10.2 AV	54.0	-43.8	1.39 V	245	15.2	-5.0
5	4960.00	48.0 PK	74.0	-26.0	1.39 V	327	45.5	2.5
6	4960.00	17.5 AV	54.0	-36.5	1.39 V	327	15.0	2.5

#### Remarks:

1. Emission Level(dBuV/m) = Raw Value(dBuV) + Correction Factor(dB/m)
2. Correction Factor(dB/m) = Antenna Factor(dB/m) + Cable Factor(dB) – Pre-Amplifier Factor(dB)
3. Margin value = Emission Level – Limit value
4. The other emission levels were very low against the limit.
5. " \* " : Fundamental frequency, the limit was restricted at the RF Output Power.
6. The average value of fundamental and harmonic frequency is: Average = Peak value + 20 log(Duty cycle) Where the duty cycle correction factor is calculated from following formula:  

$$20 \log(\text{Duty cycle}) = 20 \log(3 \text{ ms} / 100 \text{ ms}) = -30.5 \text{ dB}$$

**9 kHz ~ 1 GHz Worst-Case Data:**

<b>RF Mode</b>	BT 8DPSK	<b>Channel</b>	CH 78 : 2480 MHz
<b>Frequency Range</b>	30 MHz ~ 1 GHz	<b>Detector Function &amp; Bandwidth</b>	(QP) RB = 120kHz
<b>Environmental Conditions</b>	20°C, 71% RH	<b>Tested By</b>	Noah Chang

**Antenna Polarity & Test Distance : Horizontal at 3 m**

No	Frequency (MHz)	Emission Level (dBuV/m)	Limit (dBuV/m)	Margin (dB)	Antenna Height (m)	Table Angle (Degree)	Raw Value (dBuV)	Correction Factor (dB/m)
1	40.67	31.8 QP	40.0	-8.2	1.00 H	328	45.5	-13.7
2	80.44	24.1 QP	40.0	-15.9	1.00 H	126	42.4	-18.3
3	148.34	27.8 QP	43.5	-15.7	2.00 H	18	40.9	-13.1
4	193.93	34.4 QP	43.5	-9.1	1.00 H	344	50.6	-16.2
<b>5</b>	<b>238.55</b>	<b>43.9 QP</b>	<b>46.0</b>	<b>-2.1</b>	<b>1.50 H</b>	<b>188</b>	<b>58.6</b>	<b>-14.7</b>
6	310.33	32.1 QP	46.0	-13.9	2.00 H	189	44.4	-12.3

**Remarks:**

1. Emission Level(dBuV/m) = Raw Value(dBuV) + Correction Factor(dB/m)
2. Correction Factor(dB/m) = Antenna Factor(dB/m) + Cable Factor(dB) – Pre-Amplifier Factor(dB)
3. Margin value = Emission Level – Limit value
4. The other emission levels were very low against the limit of frequency range 30 MHz ~ 1 GHz.
5. The emission levels were very low against the limit of frequency range 9 kHz ~ 30 MHz: the amplitude of spurious emissions attenuated more than 20 dB below the permissible value to be report.

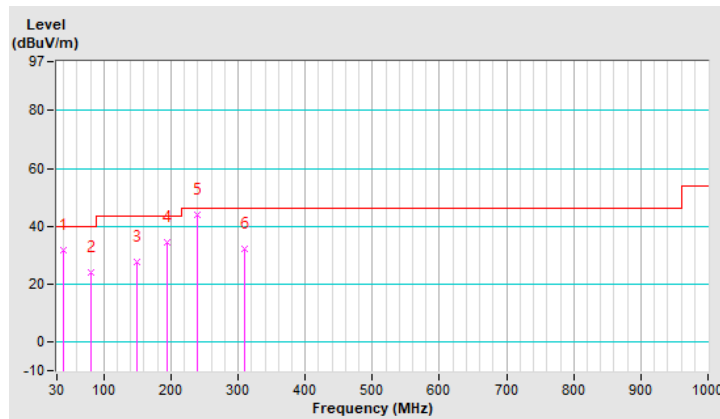



<b>RF Mode</b>	BT 8DPSK	<b>Channel</b>	CH 78 : 2480 MHz
<b>Frequency Range</b>	30 MHz ~ 1 GHz	<b>Detector Function &amp; Bandwidth</b>	(QP) RB = 120kHz
<b>Environmental Conditions</b>	20°C, 71% RH	<b>Tested By</b>	Noah Chang

Antenna Polarity & Test Distance : Vertical at 3 m								
No	Frequency (MHz)	Emission Level (dBuV/m)	Limit (dBuV/m)	Margin (dB)	Antenna Height (m)	Table Angle (Degree)	Raw Value (dBuV)	Correction Factor (dB/m)
1	40.67	25.9 QP	40.0	-14.1	2.00 V	18	39.6	-13.7
2	88.20	26.0 QP	43.5	-17.5	1.50 V	78	45.0	-19.0
3	193.93	29.6 QP	43.5	-13.9	1.00 V	336	45.8	-16.2
4	240.49	40.3 QP	46.0	-5.7	1.00 V	334	54.9	-14.6
5	312.27	22.4 QP	46.0	-23.6	1.50 V	334	34.6	-12.2
6	480.08	24.6 QP	46.0	-21.4	1.00 V	18	32.8	-8.2

**Remarks:**

1. Emission Level(dBuV/m) = Raw Value(dBuV) + Correction Factor(dB/m)
2. Correction Factor(dB/m) = Antenna Factor(dB/m) + Cable Factor(dB) – Pre-Amplifier Factor(dB)
3. Margin value = Emission Level – Limit value
4. The other emission levels were very low against the limit of frequency range 30 MHz ~ 1 GHz.
5. The emission levels were very low against the limit of frequency range 9 kHz ~ 30 MHz: the amplitude of spurious emissions attenuated more than 20 dB below the permissible value to be report.

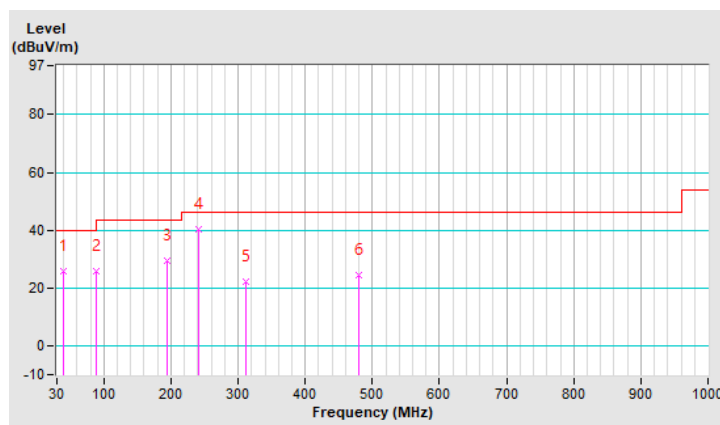

## 5 Pictures of Test Arrangements

Please refer to the attached file (Test Setup Photo).

## Annex A- Band Edge Measurement

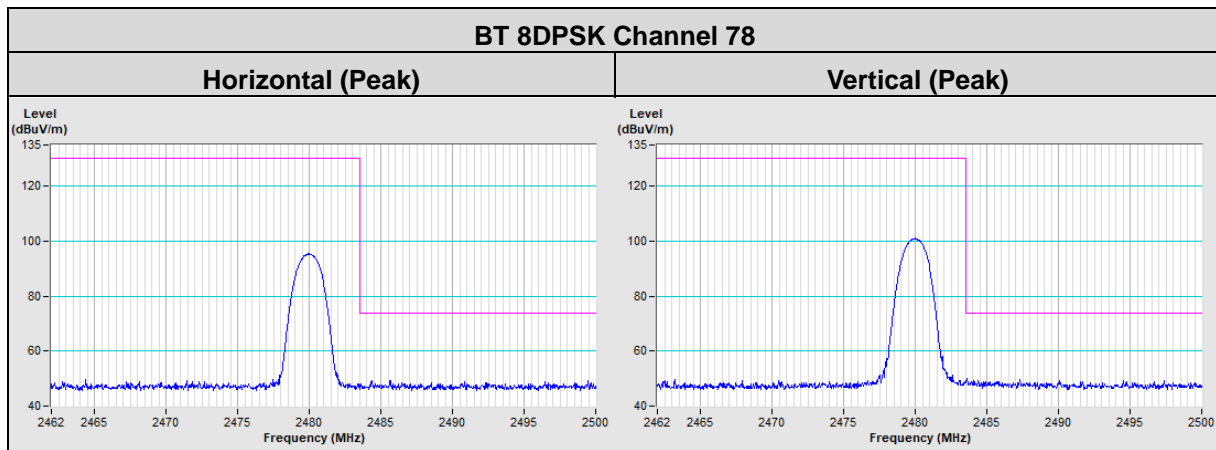

## Appendix – Information of the Testing Laboratories

We, Bureau Veritas Consumer Products Services (H.K.) Ltd., Taoyuan Branch, were founded in 1988 to provide our best service in EMC, Radio, Telecom and Safety consultation. Our laboratories are FCC recognized accredited test firms and accredited according to ISO/IEC 17025.

If you have any comments, please feel free to contact us at the following:

### Lin Kou EMC/RF Lab

Tel: 886-2-26052180

Fax: 886-2-26051924

### Hsin Chu EMC/RF/Telecom Lab

Tel: 886-3-6668565

Fax: 886-3-6668323

### Hwa Ya EMC/RF/Safety Lab

Tel: 886-3-3183232

Fax: 886-3-3270892

**Email:** [service.adt@tw.bureauveritas.com](mailto:service.adt@tw.bureauveritas.com)

**Web Site:** [www.bureauveritas-adt.com](http://www.bureauveritas-adt.com)

The address and road map of all our labs can be found in our web site also.

--- END ---