

FCC Test Report

Report No.: RF181127C08-1

FCC ID: W23-WMU62XX

Test Model: WMU6202, WMU6206

Series Model: WMU6203, WMU6204, WMU6205, WMU6207

Received Date: Nov. 27, 2018

Test Date: Jan. 14, 2019 ~ Jan. 18, 2019

Issued Date: Jan. 28, 2019

Applicant: jjPlus Corporation

Address: 13F., No.120-3, Qiaoh Rd. Zhonghe Dist., New Taipei City 23584 Taiwan (R.O.C.)

Issued By: Bureau Veritas Consumer Products Services (H.K.) Ltd., Taoyuan Branch

Lab Address: No. 47-2, 14th Ling, Chia Pau Vil., Lin Kou Dist., New Taipei City, Taiwan (R.O.C)

Test Location (1): No.19, Hwa Ya 2nd Rd., Wen Hwa Vil., Kwei Shan Dist., Taoyuan City 33383, Taiwan, R.O.C.

Test Location (2): B2F., No.215, Sec. 3, Beixin Rd., Xindian Dist., New Taipei City 231, Taiwan, R.O.C

**FCC Registration /
Designation Number:** 427177 / TW0011



This report is for your exclusive use. Any copying or replication of this report to or for any other person or entity, or use of our name or trademark, is permitted only with our prior written permission. This report sets forth our findings solely with respect to the test samples identified herein. The results set forth in this report are not indicative or representative of the quality or characteristics of the lot from which a test sample was taken or any similar or identical product unless specifically and expressly noted. Our report includes all of the tests requested by you and the results thereof based upon the information that you provided to us. You have 60 days from date of issuance of this report to notify us of any material error or omission caused by our negligence, provided, however, that such notice shall be in writing and shall specifically address the issue you wish to raise. A failure to raise such issue within the prescribed time shall constitute your unqualified acceptance of the completeness of this report, the tests conducted and the correctness of the report contents. Unless specific mention, the uncertainty of measurement has been explicitly taken into account to declare the compliance or non-compliance to the specification. The report must not be used by the client to claim product certification, approval, or endorsement by TAF or any government agencies.

Table of Contents

Release Control Record	4
1 Certificate of Conformity	5
2 Summary of Test Results	6
2.1 Measurement Uncertainty	6
2.2 Modification Record	6
3 General Information	7
3.1 General Description of EUT	7
3.2 Description of Test Modes	8
3.2.1 Test Mode Applicability and Tested Channel Detail	9
3.3 Duty Cycle of Test Signal	10
3.4 Description of Support Units	11
3.4.1 Configuration of System under Test	11
3.5 General Description of Applied Standards	12
4 Test Types and Results	13
4.1 Radiated Emission and Bandedge Measurement	13
4.1.1 Limits of Radiated Emission and Bandedge Measurement	13
4.1.2 Test Instruments	14
4.1.3 Test Procedures	15
4.1.4 Deviation from Test Standard	15
4.1.5 Test Set Up	16
4.1.6 EUT Operating Conditions	17
4.1.7 Test Results	18
4.2 Conducted Emission Measurement	28
4.2.1 Limits of Conducted Emission Measurement	28
4.2.2 Test Instruments	28
4.2.3 Test Procedures	28
4.2.4 Deviation from Test Standard	29
4.2.5 Test Setup	29
4.2.6 EUT Operating Conditions	29
4.2.7 Test Results	30
4.3 6 dB Bandwidth Measurement	34
4.3.1 Limits of 6 dB Bandwidth Measurement	34
4.3.2 Test Setup	34
4.3.3 Test Instruments	34
4.3.4 Test Procedure	34
4.3.5 Deviation from Test Standard	34
4.3.6 EUT Operating Conditions	34
4.3.7 Test Results	35
4.4 Occupied Bandwidth Measurement	36
4.4.1 Test Setup	36
4.4.2 Test Instruments	36
4.4.3 Test Procedure	36
4.4.4 Deviation from Test Standard	36
4.4.5 EUT Operating Conditions	36
4.4.6 Test Results	37
4.5 Conducted Output Power Measurement	38
4.5.1 Limits of Conducted Output Power Measurement	38
4.5.2 Test Setup	38
4.5.3 Test Instruments	38
4.5.4 Test Procedures	38
4.5.5 Deviation from Test Standard	38
4.5.6 EUT Operating Conditions	38
4.5.7 Test Results	38

4.6	Power Spectral Density Measurement	39
4.6.1	Limits of Power Spectral Density Measurement.....	39
4.6.2	Test Setup.....	39
4.6.3	Test Instruments	39
4.6.4	Test Procedure	39
4.6.5	Deviation from Test Standard	39
4.6.6	EUT Operating Condition	39
4.6.7	Test Results	40
4.7	Conducted Out of Band Emission Measurement	41
4.7.1	Limits of Conducted Out of Band Emission Measurement.....	41
4.7.2	Test Setup.....	41
4.7.3	Test Instruments	41
4.7.4	Test Procedure	41
4.7.5	Deviation from Test Standard	41
4.7.6	EUT Operating Condition	41
4.7.7	Test Results	42
5	Pictures of Test Arrangements.....	43
	Appendix – Information of the Testing Laboratories	44

Release Control Record

Issue No.	Description	Date Issued
RF181127C08-1	Original Release	Jan. 28, 2019

1 Certificate of Conformity

Product: 11ac 2T2R WIFI & BT Module

Brand: jjPlus

Test Model: WMU6202, WMU6206

Series Model: WMU6203, WMU6204, WMU6205, WMU6207

Sample Status: wifi module

Applicant: jjPlus Corporation

Test Date: Jan. 14, 2019 ~ Jan. 18, 2019

Standards: 47 CFR FCC Part 15, Subpart C (Section 15.247)
ANSI C63.10:2013

The above equipment has been tested by **Bureau Veritas Consumer Products Services (H.K.) Ltd., Taoyuan Branch**, and found compliance with the requirement of the above standards. The test record, data evaluation & Equipment Under Test (EUT) configurations represented herein are true and accurate accounts of the measurements of the sample's RF characteristics under the conditions specified in this report.

Prepared by : , **Date:** Jan. 28, 2019
Gina Liu / Specialist

Approved by : , **Date:** Jan. 28, 2019
Dylan Chiou / Project Engineer

2 Summary of Test Results

47 CFR FCC Part 15, Subpart C (Section 15.247)			
FCC Clause	Test Item	Result	Remarks
15.207	AC Power Conducted Emission	Pass	Meet the requirement of limit. Minimum passing margin is -12.65 dB at 0.16575 MHz.
15.205 & 209	Radiated Emissions	Pass	Meet the requirement of limit. Minimum passing margin is -1.27 dB at 7206 MHz.
15.247(d)	Band Edge Measurement	Pass	Meet the requirement of limit.
15.247(d)	Antenna Port Emission	Pass	Meet the requirement of limit.
15.247(a)(2)	6 dB Bandwidth	Pass	Meet the requirement of limit.
---	Occupied Bandwidth Measurement	Pass	Reference only
15.247(b)	Conducted Power	Pass	Meet the requirement of limit.
15.247(e)	Power Spectral Density	Pass	Meet the requirement of limit.
15.203	Antenna Requirement	Pass	No antenna connector is used. (for WMU6206) Antenna connector is U.FLx2 not a standard connector.(for WMU6202)

Note: Determining compliance based on the results of the compliance measurement, not taking into account measurement instrumentation uncertainty.

2.1 Measurement Uncertainty

Where relevant, the following measurement uncertainty levels have been estimated for tests performed on the EUT as specified in CISPR 16-4-2:

Measurement	Frequency	Expanded Uncertainty (k=2) (±)
Conducted Emissions at mains ports	150 kHz ~ 30 MHz	2.44 dB
Radiated Emissions up to 1 GHz	30 MHz ~ 200 MHz	2.0153 dB
	200 MHz ~ 1000 MHz	2.0224 dB
Radiated Emissions above 1 GHz	1 GHz ~ 18 GHz	1.0121 dB
	18 GHz ~ 40 GHz	1.1508 dB

2.2 Modification Record

There were no modifications required for compliance.

3 General Information

3.1 General Description of EUT

Product	11ac 2T2R WIFI & BT Module
Brand	jjPlus
Test Model	WMU6202, WMU6206
Series Model	WMU6203, WMU6204, WMU6205, WMU6207
Status of EUT	wifi module
Power Supply Rating	3.3 Vdc (host equipment)
Modulation Type	GFSK
Transfer Rate	1 Mbps
Operating Frequency	2402 ~ 2480 MHz
Number of Channel	40
Output Power	2.63 mW
Antenna Type	Refer to Note
Antenna Connector	Refer to Note
Accessory Device	N/A
Data Cable Supplied	N/A

Note:

1. All models and antennas are listed as below.

Test Mode	Model	RF Chip	RF Design	Interface	Antenna type	Antenna connector
v	WMU6202	RTL8822BU	The Same	mPCIe	Dipole	U.FLx2
	WMU6203			M.2		MHF4
	WMU6204			USB Type-A		U.FLx2
	WMU6205			4Pin Wafer		U.FLx2
v	WMU6206			USB Type-A	PCB Antenna	none (like solder)
	WMU6207			4Pin Wafer	x2	none (like solder)

*The difference Models are pre-tested, because the connector and interface are difference with difference Model, and selected the worst Model for testing.

*Model WMU6202, WMU6203, WMU6204 and WMU6205 the difference doesn't affect the test result, only WMU6202 was chosen for the final test.

*Model WMU6206 and WMU6207 the difference doesn't affect the test result, only WMU6206 was chosen for the final test.

2. The antennas information is listed as below.

Antenna Type	Brand	Model	Antenna Gain (dBi)		
			BT	2.4G	5G
Dipole	LYNwave	AOA160-221020-000000	3.0	3.0	2.0
	LYNwave	AOA160-221034-000000	3.0	3.0	3.0
	LYNwave	AOA160-221050-000000	5.0	5.0	5.0
PCB	N/A	N/A	3.6	3.6	5.3
	N/A	N/A	3.6	3.6	4.7

3. The above EUT information is declared by manufacturer and for more detailed features description, please refers to the manufacturer's specifications or User's Manual.

3.2 Description of Test Modes

40 channels are provided to this EUT:

Channel	Freq. (MHz)	Channel	Freq. (MHz)	Channel	Freq. (MHz)	Channel	Freq. (MHz)
0	2402	10	2422	20	2442	30	2462
1	2404	11	2424	21	2444	31	2464
2	2406	12	2426	22	2446	32	2466
3	2408	13	2428	23	2448	33	2468
4	2410	14	2430	24	2450	34	2470
5	2412	15	2432	25	2452	35	2472
6	2414	16	2434	26	2454	36	2474
7	2416	17	2436	27	2456	37	2476
8	2418	18	2438	28	2458	38	2478
9	2420	19	2440	29	2460	39	2480

3.2.1 Test Mode Applicability and Tested Channel Detail

EUT Configure Mode	Applicable To				Description
	RE≥1G	RE<1G	PLC	APCM	
A	√	√	√	√	WMU6202
B	√	√	√	-	WMU6206

Where **RE≥1G**: Radiated Emission above 1 GHz **RE<1G**: Radiated Emission below 1 GHz
PLC: Power Line Conducted Emission **APCM**: Antenna Port Conducted Measurement

Note: The EUT had been pre-tested on the positioned of each 3 axis. The worst case was found when positioned on **Z-plane** for Mode A and **X-plane** for Mode B.

Note: "-" means no effect.

Radiated Emission Test (Above 1 GHz):

- Pre-Scan has been conducted to determine the worst-case mode from all possible combinations between available modulations, data rates and antenna ports (if EUT with antenna diversity architecture).
- Following channel(s) was (were) selected for the final test as listed below.

EUT Configure Mode	Available Channel	Tested Channel	Modulation Type	Data Rate (Mbps)
A, B	0 to 39	0, 19, 39	GFSK	1

Radiated Emission Test (Below 1 GHz):

- Pre-Scan has been conducted to determine the worst-case mode from all possible combinations between available modulations, data rates and antenna ports (if EUT with antenna diversity architecture).
- Following channel(s) was (were) selected for the final test as listed below.

EUT Configure Mode	Available Channel	Tested Channel	Modulation Type	Data Rate (Mbps)
A, B	0 to 39	0	GFSK	1

Power Line Conducted Emission Test:

- Pre-Scan has been conducted to determine the worst-case mode from all possible combinations between available modulations, data rates and antenna ports (if EUT with antenna diversity architecture).
- Following channel(s) was (were) selected for the final test as listed below.

EUT Configure Mode	Available Channel	Tested Channel	Modulation Type	Data Rate (Mbps)
A, B	0 to 39	0	GFSK	1

Antenna Port Conducted Measurement:

- This item includes all test value of each mode, but only includes spectrum plot of worst value of each mode.
- Pre-Scan has been conducted to determine the worst-case mode from all possible combinations between available modulations, data rates and antenna ports (if EUT with antenna diversity architecture).
- Following channel(s) was (were) selected for the final test as listed below.

EUT Configure Mode	Available Channel	Tested Channel	Modulation Type	Data Rate (Mbps)
A	0 to 39	0, 19, 39	GFSK	1

Test Condition:

Applicable To	Environmental Conditions	Input Power	Tested by
RE≥1G	25 deg. C, 65 % RH	120 Vac, 60 Hz	Karl Lee, Charles Hsiao
RE<1G	25 deg. C, 65 % RH	120 Vac, 60 Hz	Karl Lee, Harry Hsueh
PLC	25 deg. C, 65 % RH	120 Vac, 60 Hz	Jisyone Wang
APCM	25 deg. C, 65 % RH	3.3 Vdc	Gavin Wu

3.3 Duty Cycle of Test Signal

Duty cycle = 382/627 = 0.609, Duty factor = 10 * log(1/0.609) = 2.15

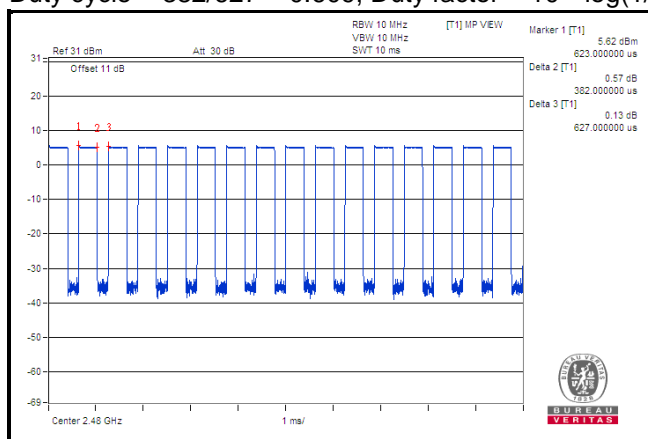

3.4 Description of Support Units

The EUT has been tested as an independent unit together with other necessary accessories or support units. The following support units or accessories were used to form a representative test configuration during the tests.

No.	Product	Brand	Model No.	Serial No.	FCC ID
1.	Notebook	DELL	E6420	D3T96R1	N/A

No.	Signal Cable Description of The Above Support Units
1.	N/A

Note:

1. All power cords of the above support units are non-shielded (1.8m).

3.4.1 Configuration of System under Test

Mode A

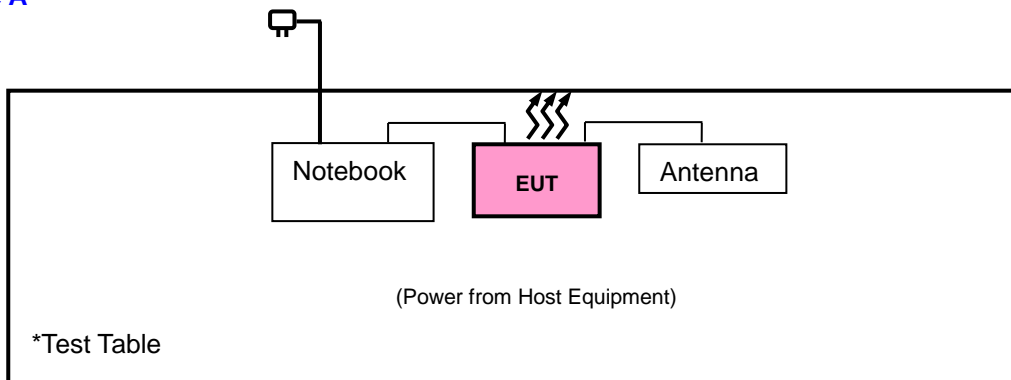

Mode B

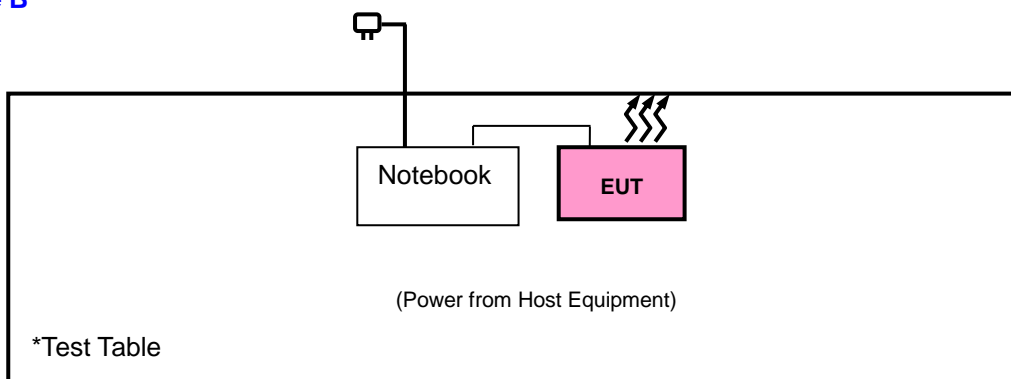

3.5 General Description of Applied Standards

The EUT is a RF Product. According to the specifications of the manufacturer, it must comply with the requirements of the following standards:

FCC Part 15, Subpart C (15.247)

KDB 558074 D01 15.247 Meas Guidance v05

ANSI C63.10-2013

All test items have been performed and recorded as per the above standards.

4 Test Types and Results

4.1 Radiated Emission and Bandedge Measurement

4.1.1 Limits of Radiated Emission and Bandedge Measurement

Radiated emissions which fall in the restricted bands must comply with the radiated emission limits specified as below table. Other emissions shall be at least 20 dB below the highest level of the desired power:

Frequencies (MHz)	Field Strength (microvolts/meter)	Measurement Distance (meters)
0.009 ~ 0.490	2400/F (kHz)	300
0.490 ~ 1.705	24000/F (kHz)	30
1.705 ~ 30.0	30	30
30 ~ 88	100	3
88 ~ 216	150	3
216 ~ 960	200	3
Above 960	500	3

Note:

1. The lower limit shall apply at the transition frequencies.
2. Emission level (dBuV/m) = 20 log Emission level (uV/m).
3. For frequencies above 1000 MHz, the field strength limits are based on average detector, however, the peak field strength of any emission shall not exceed the maximum permitted average limits, specified above by more than 20 dB under any condition of modulation.

4.1.2 Test Instruments

Description & Manufacturer	Model No.	Serial No.	Date of Calibration	Due Date of Calibration
Test Receiver Agilent Technologies	N9038A	MY52260177	Aug. 20, 2018	Aug. 19, 2019
Spectrum Analyzer ROHDE & SCHWARZ	FSV40	100980	Apr. 17, 2018	Apr. 16, 2019
HORN Antenna ETS-Lindgren	3117	00143293	Nov. 25, 2018	Nov. 24, 2019
BILOG Antenna SCHWARZBECK	VULB 9168	9168-616	Nov. 27, 2018	Nov. 26, 2019
HORN Antenna SCHWARZBECK	BBHA 9170	9170-480	Nov. 25, 2018	Nov. 24, 2019
Fixed Attenuator Woken	00801A1GGAM02Y	NA	May 17, 2018	May 16, 2019
Loop Antenna	EM-6879	269	Sep. 07, 2018	Sep. 06, 2019
Preamplifier Agilent	310N	187226	Jun. 19, 2018	Jun. 18, 2019
Preamplifier Agilent	83017A	MY39501357	Jun. 19, 2018	Jun. 18, 2019
Preamplifier EMCI	EMC 184045	980116	Oct. 12, 2018	Oct. 11, 2019
Power Meter Anritsu	ML2495A	1012010	Sep. 05, 2018	Sep. 04, 2019
Power Sensor Anritsu	MA2411B	1315050	Sep. 04, 2018	Sep. 03, 2019
RF signal cable ETS-LINDGREN	5D-FB	Cable-CH1-01(RFC -SMS-100-SMS-12 0+RFC-SMS-100-S MS-400)	Jun. 19, 2018	Jun. 18, 2019
RF signal cable ETS-LINDGREN	8D-FB	Cable-CH1-02(RFC -SMS-100-SMS-24)	Jun. 19, 2018	Jun. 18, 2019
Boresight Antenna Fixture	FBA-01	FBA-SIP01	NA	NA
Software BV ADT	E3 8.130425b	NA	NA	NA
Antenna Tower MF	NA	NA	NA	NA
Turn Table MF	NA	NA	NA	NA
Antenna Tower & Turn Table Controller MF	MF-7802	NA	NA	NA

- Note: 1. The calibration interval of the above test instruments is 12 months and the calibrations are traceable to NML/ROC and NIST/USA.
2. The test was performed in HsinTien Chamber 1.
3. The horn antenna and preamplifier (model: 83017A) are used only for the measurement of emission frequency above 1 GHz if tested.
4. The IC Site Registration No. is IC7450I-1.

4.1.3 Test Procedures

For Radiated Emission below 30 MHz

- a. The EUT was placed on the top of a rotating table 0.8 meters above the ground at a 3 meter chamber room. The table was rotated 360 degrees to determine the position of the highest radiation.
- b. The EUT was set 3 meters away from the interference-receiving antenna, which was mounted on the top of a variable-height antenna tower.
- c. Parallel, perpendicular, and ground-parallel orientations of the antenna are set to make the measurement.
- d. For each suspected emission, the EUT was arranged to its worst case and the rotatable table was turned from 0 degrees to 360 degrees to find the maximum reading.
- e. The test-receiver system was set to Quasi-Peak Detect Function and Specified Bandwidth with Maximum Hold Mode.

Note:

1. The resolution bandwidth and video bandwidth of test receiver/spectrum analyzer is 9 kHz at frequency below 30 MHz.

For Radiated Emission above 30 MHz

- a. The EUT was placed on the top of a rotating table 0.8 meters (for 30 MHz ~ 1 GHz) / 1.5 meters (for above 1 GHz) above the ground at 3 meter chamber room for test. The table was rotated 360 degrees to determine the position of the highest radiation.
- b. The EUT was set 3 meters away from the interference-receiving antenna, which was mounted on the top of a variable-height antenna tower.
- c. The height of antenna is varied from one meter to four meters above the ground to determine the maximum value of the field strength. Both horizontal and vertical polarizations of the antenna are set to make the measurement.
- d. For each suspected emission, the EUT was arranged to its worst case and then the antenna was tuned to heights from 1 meter to 4 meters and the rotatable table was turned from 0 degrees to 360 degrees to find the maximum reading.
- e. The test-receiver system was set to quasi-peak detect function and specified bandwidth with maximum hold mode when the test frequency is below 1 GHz.
- f. The test-receiver system was set to peak and average detected function and specified bandwidth with maximum hold mode when the test frequency is above 1 GHz. If the peak reading value also meets average limit, measurement with the average detector is unnecessary.

Note:

1. The resolution bandwidth and video bandwidth of test receiver/spectrum analyzer is 120 kHz for Quasi-peak detection (QP) or Peak detection (PK) at frequency below 1 GHz.
2. The resolution bandwidth of test receiver/spectrum analyzer is 1 MHz and the video bandwidth is 3 MHz for Peak detection (PK) at frequency above 1 GHz.
3. The resolution bandwidth of test receiver/spectrum analyzer is 1 MHz and the video bandwidth is $\geq 1/T$ (Duty cycle < 98 %) or 10 Hz (Duty cycle ≥ 98 %) for Average detection (AV) at frequency above 1 GHz. (RBW = 1 MHz, VBW = 3 kHz)
4. All modes of operation were investigated and the worst-case emissions are reported.

4.1.4 Deviation from Test Standard

No deviation.

4.1.5 Test Set Up

<Radiated Emission below 30 MHz>

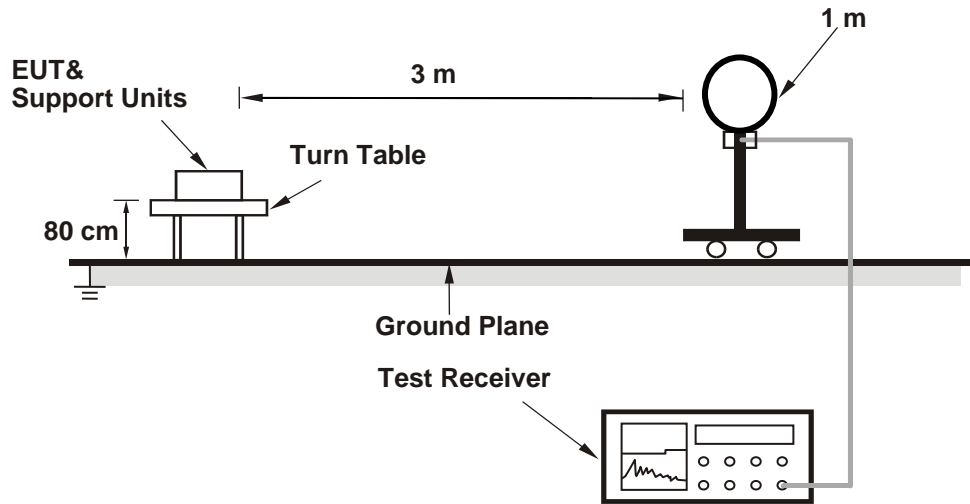

<Radiated Emission 30 MHz to 1 GHz>

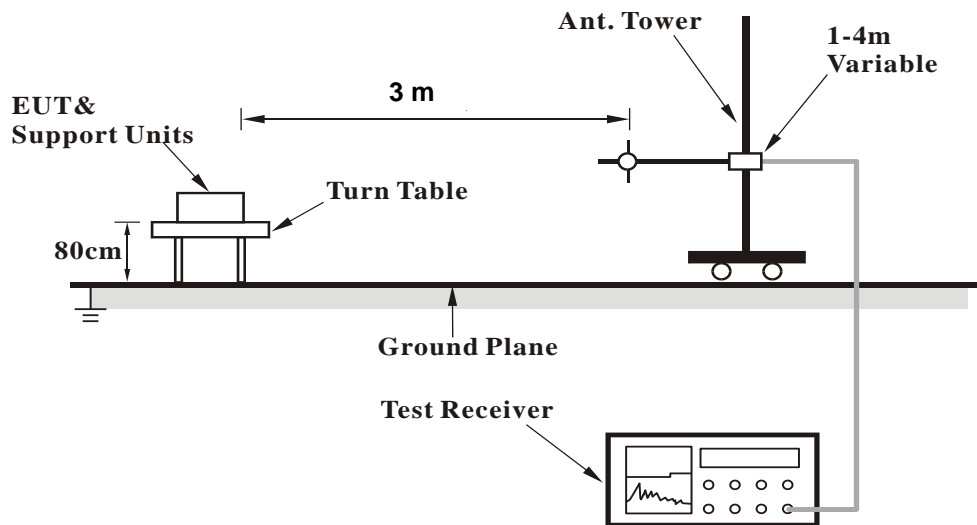

<Radiated Emission above 1 GHz>

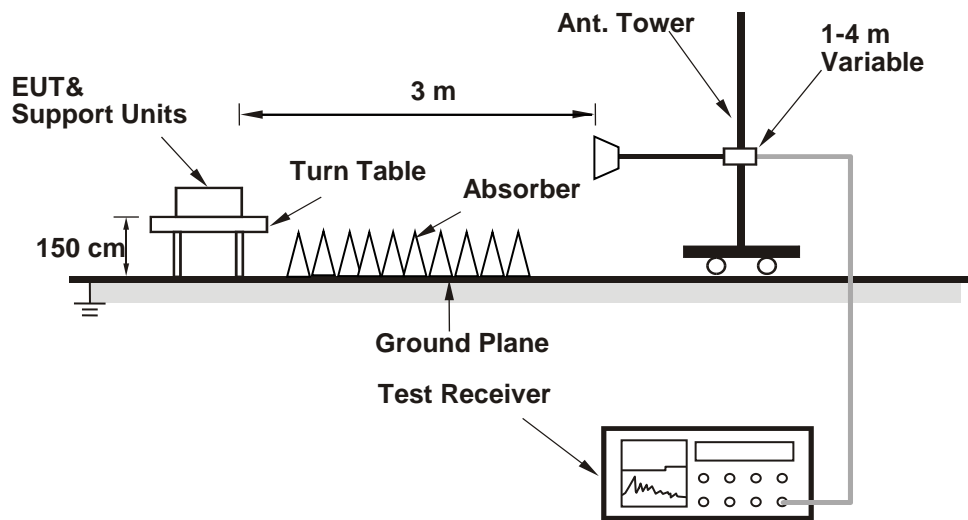

For the actual test configuration, please refer to the attached file (Test Setup Photo).

4.1.6 EUT Operating Conditions

- a. Placed the EUT on the testing table.
- b. Set the EUT under transmission condition continuously at specific channel frequency.

4.1.7 Test Results

Above 1 GHz Data:
Mode A

EUT Test Condition		Measurement Detail	
Channel	Channel 0	Frequency Range	1 GHz ~ 25 GHz
Input Power	120 Vac, 60 Hz	Detector Function	Peak (PK) Average (AV)
Environmental Conditions	25 deg. C, 65 % RH	Tested By	Karl Lee

Antennal Polarity & Test Distance: Horizontal at 3 m										
Frequency (MHz)	Emission Level (dBuV/m)	Read Level (dBuV)	Limit (dBuV/m)	Margin (dB)	Antenna Factor (dB/m)	Cable Loss (dB)	Preamp Factor (dB)	Antenna Height (cm)	Table Angle (Degree)	Remark
2382.99	40.5	34.08	54	-13.5	31.78	5.4	30.76	107	360	Average
2382.99	51.58	45.16	74	-22.42	31.78	5.4	30.76	107	360	Peak
2402	95.7	89.23			31.8	5.4	30.73	107	360	Average
2402	96.67	90.2			31.8	5.4	30.73	107	360	Peak
4804	39.12	26.7	54	-14.88	33.96	8.25	29.79	185	39	Average
4804	49.37	36.95	74	-24.63	33.96	8.25	29.79	185	39	Peak

Antennal Polarity & Test Distance: Vertical at 3 m										
Frequency (MHz)	Emission Level (dBuV/m)	Read Level (dBuV)	Limit (dBuV/m)	Margin (dB)	Antenna Factor (dB/m)	Cable Loss (dB)	Preamp Factor (dB)	Antenna Height (cm)	Table Angle (Degree)	Remark
2381.73	41.39	34.97	54	-12.61	31.78	5.4	30.76	161	300	Average
2381.73	55.16	48.74	74	-18.84	31.78	5.4	30.76	161	300	Peak
2402	106.09	99.62			31.8	5.4	30.73	161	300	Average
2402	107.09	100.62			31.8	5.4	30.73	161	300	Peak
4804	40.21	27.79	54	-13.79	33.96	8.25	29.79	129	288	Average
4804	50.31	37.89	74	-23.69	33.96	8.25	29.79	129	288	Peak

Remarks:

- Emission Level = Read Level + Antenna Factor + Cable Loss - Preamp Factor
Margin value = Emission level – Limit value
- 2402 MHz: Fundamental frequency.
- The emission levels of other frequencies were very low against the limit.

EUT Test Condition		Measurement Detail	
Channel	Channel 19	Frequency Range	1 GHz ~ 25 GHz
Input Power	120 Vac, 60 Hz	Detector Function	Peak (PK) Average (AV)
Environmental Conditions	25 deg. C, 65 % RH	Tested By	Karl Lee

Antennal Polarity & Test Distance: Horizontal at 3 m										
Frequency (MHz)	Emission Level (dBuV/m)	Read Level (dBuV)	Limit (dBuV/m)	Margin (dB)	Antenna Factor (dB/m)	Cable Loss (dB)	Preamp Factor (dB)	Antenna Height (cm)	Table Angle (Degree)	Remark
2388.03	40.4	33.96	54	-13.6	31.8	5.4	30.76	107	360	Average
2388.03	51.63	45.19	74	-22.37	31.8	5.4	30.76	107	360	Peak
2440	95.88	89.26			31.85	5.46	30.69	107	360	Average
2440	96.92	90.3			31.85	5.46	30.69	107	360	Peak
2494.68	41.2	34.35	54	-12.8	31.9	5.53	30.58	107	360	Average
2494.68	54.17	47.32	74	-19.83	31.9	5.53	30.58	107	360	Peak
4880	39.03	26.54	54	-14.97	33.98	8.27	29.76	191	236	Average
4880	49.18	36.69	74	-24.82	33.98	8.27	29.76	191	236	Peak

Antennal Polarity & Test Distance: Vertical at 3 m										
Frequency (MHz)	Emission Level (dBuV/m)	Read Level (dBuV)	Limit (dBuV/m)	Margin (dB)	Antenna Factor (dB/m)	Cable Loss (dB)	Preamp Factor (dB)	Antenna Height (cm)	Table Angle (Degree)	Remark
2383.53	41.12	34.7	54	-12.88	31.78	5.4	30.76	161	300	Average
2383.53	54.62	48.2	74	-19.38	31.78	5.4	30.76	161	300	Peak
2440	106.44	99.82			31.85	5.46	30.69	161	300	Average
2440	107.46	100.84			31.85	5.46	30.69	161	300	Peak
2483.56	41.25	34.49	54	-12.75	31.88	5.5	30.62	161	300	Average
2483.56	53.8	47.04	74	-20.2	31.88	5.5	30.62	161	300	Peak
4880	39.27	26.78	54	-14.73	33.98	8.27	29.76	103	96	Average
4880	49.35	36.86	74	-24.65	33.98	8.27	29.76	103	96	Peak

Remarks:

- Emission Level = Read Level + Antenna Factor + Cable Loss - Preamp Factor
Margin value = Emission level – Limit value
- 2440 MHz: Fundamental frequency.
- The emission levels of other frequencies were very low against the limit.

EUT Test Condition		Measurement Detail	
Channel	Channel 39	Frequency Range	1 GHz ~ 25 GHz
Input Power	120 Vac, 60 Hz	Detector Function	Peak (PK) Average (AV)
Environmental Conditions	25 deg. C, 65 % RH	Tested By	Karl Lee

Antennal Polarity & Test Distance: Horizontal at 3 m										
Frequency (MHz)	Emission Level (dBuV/m)	Read Level (dBuV)	Limit (dBuV/m)	Margin (dB)	Antenna Factor (dB/m)	Cable Loss (dB)	Preamp Factor (dB)	Antenna Height (cm)	Table Angle (Degree)	Remark
2480	94.94	88.18			31.88	5.5	30.62	107	360	Average
2480	96.17	89.41			31.88	5.5	30.62	107	360	Peak
2486.16	41.07	34.28	54	-12.93	31.88	5.53	30.62	107	360	Average
2486.16	52.05	45.26	74	-21.95	31.88	5.53	30.62	107	360	Peak
4960	39.24	26.68	54	-14.76	33.99	8.29	29.72	154	168	Average
4960	49.55	36.99	74	-24.45	33.99	8.29	29.72	154	168	Peak

Antennal Polarity & Test Distance: Vertical at 3 m										
Frequency (MHz)	Emission Level (dBuV/m)	Read Level (dBuV)	Limit (dBuV/m)	Margin (dB)	Antenna Factor (dB/m)	Cable Loss (dB)	Preamp Factor (dB)	Antenna Height (cm)	Table Angle (Degree)	Remark
2480	106.05	99.29			31.88	5.5	30.62	161	300	Average
2480	107.23	100.47			31.88	5.5	30.62	161	300	Peak
2483.56	43.87	37.11	54	-10.13	31.88	5.5	30.62	161	300	Average
2483.56	55.13	48.37	74	-18.87	31.88	5.5	30.62	161	300	Peak
4960	39.52	26.96	54	-14.48	33.99	8.29	29.72	146	113	Average
4960	49.87	37.31	74	-24.13	33.99	8.29	29.72	146	113	Peak

Remarks:

- Emission Level = Read Level + Antenna Factor + Cable Loss - Preamp Factor
Margin value = Emission level – Limit value
- 2480 MHz: Fundamental frequency.
- The emission levels of other frequencies were very low against the limit.

Mode B

EUT Test Condition		Measurement Detail	
Channel	Channel 0	Frequency Range	1 GHz ~ 25 GHz
Input Power	120 Vac, 60 Hz	Detector Function	Peak (PK) Average (AV)
Environmental Conditions	25 deg. C, 65 % RH	Tested By	Charles Hsiao

Antennal Polarity & Test Distance: Horizontal at 3 m										
Frequency (MHz)	Emission Level (dBuV/m)	Read Level (dBuV)	Limit (dBuV/m)	Margin (dB)	Antenna Factor (dB/m)	Cable Loss (dB)	Preamp Factor (dB)	Antenna Height (cm)	Table Angle (Degree)	Remark
2374.8	40.83	34.44	54	-13.17	31.78	5.37	30.76	100	204	Average
2374.8	51.65	45.26	74	-22.35	31.78	5.37	30.76	100	204	Peak
2402	98.2	91.73			31.8	5.4	30.73	100	204	Average
2402	99.14	92.67			31.8	5.4	30.73	100	204	Peak
4804	44.72	32.3	54	-9.28	33.96	8.25	29.79	100	124	Average
4804	49.73	37.31	74	-24.27	33.96	8.25	29.79	100	124	Peak
7206	52.73	38.26	54	-1.27	35.56	9.94	31.03	116	202	Average
7206	55.09	40.62	74	-18.91	35.56	9.94	31.03	116	202	Peak

Antennal Polarity & Test Distance: Vertical at 3 m										
Frequency (MHz)	Emission Level (dBuV/m)	Read Level (dBuV)	Limit (dBuV/m)	Margin (dB)	Antenna Factor (dB/m)	Cable Loss (dB)	Preamp Factor (dB)	Antenna Height (cm)	Table Angle (Degree)	Remark
2382.27	41.04	34.62	54	-12.96	31.78	5.4	30.76	100	258	Average
2382.27	52.08	45.66	74	-21.92	31.78	5.4	30.76	100	258	Peak
2402	92.57	86.1			31.8	5.4	30.73	100	258	Average
2402	93.7	87.23			31.8	5.4	30.73	100	258	Peak
4804	39.76	27.34	54	-14.24	33.96	8.25	29.79	100	299	Average
4804	50.33	37.91	74	-23.67	33.96	8.25	29.79	100	299	Peak
7206	52.07	37.6	54	-1.93	35.56	9.94	31.03	100	302	Average
7206	57.18	42.71	74	-16.82	35.56	9.94	31.03	100	302	Peak

Remarks:

- Emission Level = Read Level + Antenna Factor + Cable Loss - Preamp Factor
Margin value = Emission level – Limit value
- 2402 MHz: Fundamental frequency.
- The emission levels of other frequencies were very low against the limit.

EUT Test Condition		Measurement Detail	
Channel	Channel 19	Frequency Range	1 GHz ~ 25 GHz
Input Power	120 Vac, 60 Hz	Detector Function	Peak (PK) Average (AV)
Environmental Conditions	25 deg. C, 65 % RH	Tested By	Charles Hsiao

Antennal Polarity & Test Distance: Horizontal at 3 m										
Frequency (MHz)	Emission Level (dBuV/m)	Read Level (dBuV)	Limit (dBuV/m)	Margin (dB)	Antenna Factor (dB/m)	Cable Loss (dB)	Preamp Factor (dB)	Antenna Height (cm)	Table Angle (Degree)	Remark
2389.2	41.14	34.7	54	-12.86	31.8	5.4	30.76	100	204	Average
2389.2	52.34	45.9	74	-21.66	31.8	5.4	30.76	100	204	Peak
2440	98.53	91.91			31.85	5.46	30.69	100	204	Average
2440	99.06	92.44			31.85	5.46	30.69	100	204	Peak
2494.52	41.5	34.65	54	-12.5	31.9	5.53	30.58	100	204	Average
2494.52	53	46.15	74	-21	31.9	5.53	30.58	100	204	Peak
4880	46.63	34.14	54	-7.37	33.98	8.27	29.76	100	120	Average
4880	51.49	39	74	-22.51	33.98	8.27	29.76	100	120	Peak
7320	52.12	37.8	54	-1.88	35.53	9.95	31.16	100	208	Average
7320	56.72	42.4	74	-17.28	35.53	9.95	31.16	100	208	Peak
Antennal Polarity & Test Distance: Vertical at 3 m										
Frequency (MHz)	Emission Level (dBuV/m)	Read Level (dBuV)	Limit (dBuV/m)	Margin (dB)	Antenna Factor (dB/m)	Cable Loss (dB)	Preamp Factor (dB)	Antenna Height (cm)	Table Angle (Degree)	Remark
2363.73	40.82	34.49	54	-13.18	31.76	5.37	30.8	100	258	Average
2363.73	52.22	45.89	74	-21.78	31.76	5.37	30.8	100	258	Peak
2440	92.22	85.6			31.85	5.46	30.69	100	258	Average
2440	93.71	87.09			31.85	5.46	30.69	100	258	Peak
2486.56	41.59	34.8	54	-12.41	31.88	5.53	30.62	100	258	Average
2486.56	52.58	45.79	74	-21.42	31.88	5.53	30.62	100	258	Peak
4880	39.71	27.22	54	-14.29	33.98	8.27	29.76	100	302	Average
4880	50.52	38.03	74	-23.48	33.98	8.27	29.76	100	302	Peak
7320	50.32	36	54	-3.68	35.53	9.95	31.16	100	302	Average
7320	55.93	41.61	74	-18.07	35.53	9.95	31.16	100	300	Peak

Remarks:

- Emission Level = Read Level + Antenna Factor + Cable Loss - Preamp Factor
Margin value = Emission level – Limit value
- 2440 MHz: Fundamental frequency.
- The emission levels of other frequencies were very low against the limit.

EUT Test Condition		Measurement Detail	
Channel	Channel 39	Frequency Range	1 GHz ~ 25 GHz
Input Power	120 Vac, 60 Hz	Detector Function	Peak (PK) Average (AV)
Environmental Conditions	25 deg. C, 65 % RH	Tested By	Charles Hsiao

Antennal Polarity & Test Distance: Horizontal at 3 m										
Frequency (MHz)	Emission Level (dBuV/m)	Read Level (dBuV)	Limit (dBuV/m)	Margin (dB)	Antenna Factor (dB/m)	Cable Loss (dB)	Preamp Factor (dB)	Antenna Height (cm)	Table Angle (Degree)	Remark
2480	98.52	91.76			31.88	5.5	30.62	100	204	Average
2480	99.97	93.21			31.88	5.5	30.62	100	204	Peak
2498.6	41.8	34.95	54	-12.2	31.9	5.53	30.58	100	204	Average
2498.6	52.11	45.26	74	-21.89	31.9	5.53	30.58	100	204	Peak
4960	39.8	27.24	54	-14.2	33.99	8.29	29.72	100	100	Average
4960	50.49	37.93	74	-23.51	33.99	8.29	29.72	100	100	Peak
Antennal Polarity & Test Distance: Vertical at 3 m										
Frequency (MHz)	Emission Level (dBuV/m)	Read Level (dBuV)	Limit (dBuV/m)	Margin (dB)	Antenna Factor (dB/m)	Cable Loss (dB)	Preamp Factor (dB)	Antenna Height (cm)	Table Angle (Degree)	Remark
2480	92.1	85.34			31.88	5.5	30.62	100	258	Average
2480	93.36	86.6			31.88	5.5	30.62	100	258	Peak
2496.6	41.44	34.59	54	-12.56	31.9	5.53	30.58	100	258	Average
2496.6	52.53	45.68	74	-21.47	31.9	5.53	30.58	100	258	Peak
4960	39.59	27.03	54	-14.41	33.99	8.29	29.72	134	222	Average
4960	50.06	37.5	74	-23.94	33.99	8.29	29.72	134	222	Peak

Remarks:

- Emission Level = Read Level + Antenna Factor + Cable Loss - Preamp Factor
Margin value = Emission level – Limit value
- 2480 MHz: Fundamental frequency.
- The emission levels of other frequencies were very low against the limit.

9 kHz ~ 30 MHz Data:

The amplitude of spurious emissions attenuated more than 20 dB below the permissible value is not required to be report.

30 MHz ~ 1 GHz Worst-Case Data:

Mode A

EUT Test Condition		Measurement Detail	
Channel	Channel 0	Frequency Range	30 MHz ~ 1 GHz
Input Power	120 Vac, 60 Hz	Detector Function	Peak (PK) Quasi-peak (QP)
Environmental Conditions	25 deg. C, 65 % RH	Tested By	Harry Hsueh

Horizontal

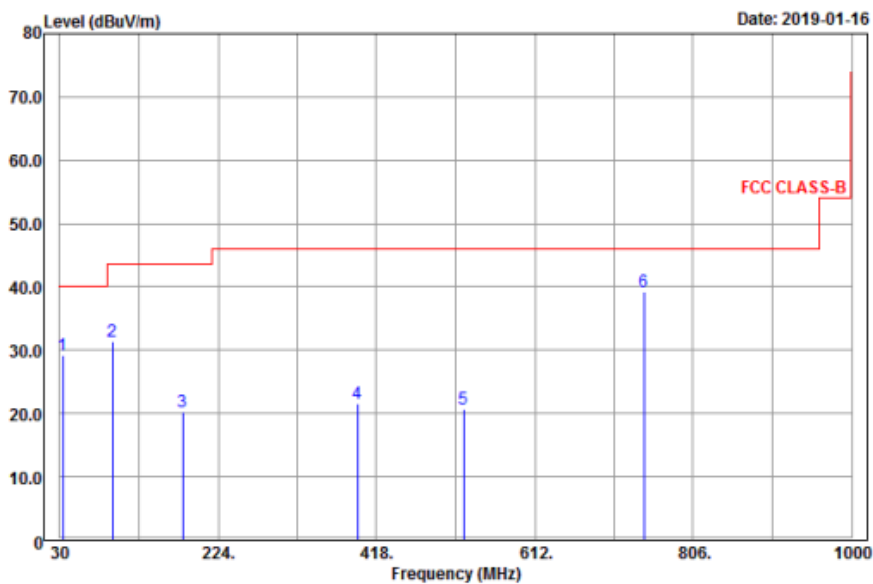

Vertical

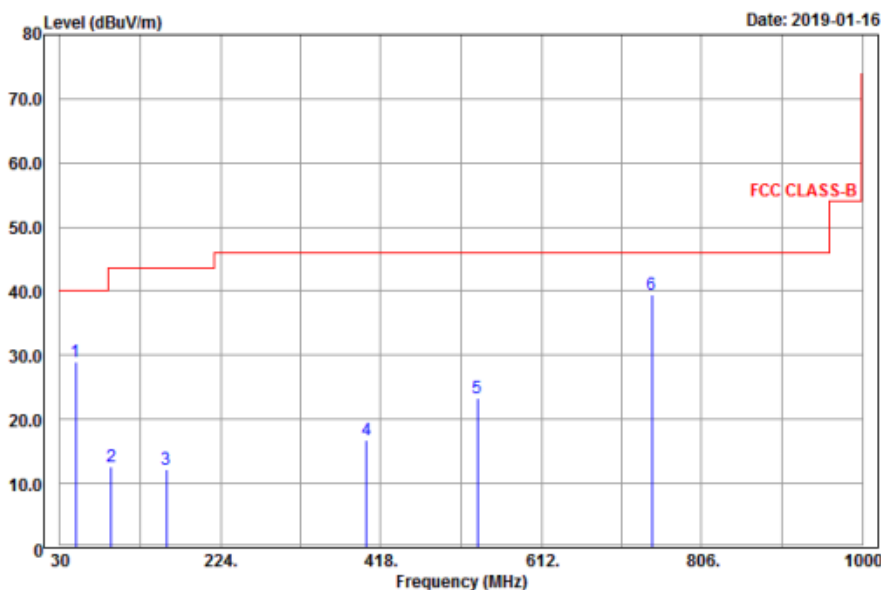

Antennal Polarity & Test Distance: Horizontal at 3 m										
Frequency (MHz)	Emission Level (dBuV/m)	Read Level (dBuV)	Limit (dBuV/m)	Margin (dB)	Antenna Factor (dB/m)	Cable Loss (dB)	Preamp Factor (dB)	Antenna Height (cm)	Table Angle (Degree)	Remark
33.51	29.27	45.55	40	-10.73	15.22	0.74	32.24	136	215	Peak
94.53	31.38	53	43.5	-12.12	9.26	1.11	31.99	155	141	Peak
180.39	20.32	40.55	43.5	-23.18	10.4	1.61	32.24	101	147	Peak
395.2	21.51	33.58	46	-24.49	17.8	2.34	32.21	136	165	Peak
524.7	20.64	29.39	46	-25.36	20.7	2.7	32.15	159	198	Peak
745.9	39.32	45.01	46	-6.68	23.23	3.22	32.14	104	114	Peak
Antennal Polarity & Test Distance: Vertical at 3 m										
Frequency (MHz)	Emission Level (dBuV/m)	Read Level (dBuV)	Limit (dBuV/m)	Margin (dB)	Antenna Factor (dB/m)	Cable Loss (dB)	Preamp Factor (dB)	Antenna Height (cm)	Table Angle (Degree)	Remark
49.17	28.98	52.24	40	-11.02	8.06	0.9	32.22	121	133	Peak
91.83	12.71	34.36	43.5	-30.79	9.06	1.11	31.82	155	187	Peak
158.79	12.19	32.2	43.5	-31.31	10.74	1.52	32.27	111	101	Peak
400.8	16.74	28.56	46	-29.26	18.06	2.34	32.22	102	321	Peak
534.5	23.38	32.33	46	-22.62	20.52	2.7	32.17	126	152	Peak
745.9	39.54	45.23	46	-6.46	23.23	3.22	32.14	100	125	Peak

Remarks:

- Emission Level = Read Level + Antenna Factor + Cable Loss - Preamp Factor
Margin value = Emission level – Limit value
- The emission levels of other frequencies were very low against the limit.

Mode B

EUT Test Condition		Measurement Detail	
Channel	Channel 0	Frequency Range	30 MHz ~ 1 GHz
Input Power	120 Vac, 60 Hz	Detector Function	Peak (PK) Quasi-peak (QP)
Environmental Conditions	25 deg. C, 65 % RH	Tested By	Karl Lee

Horizontal

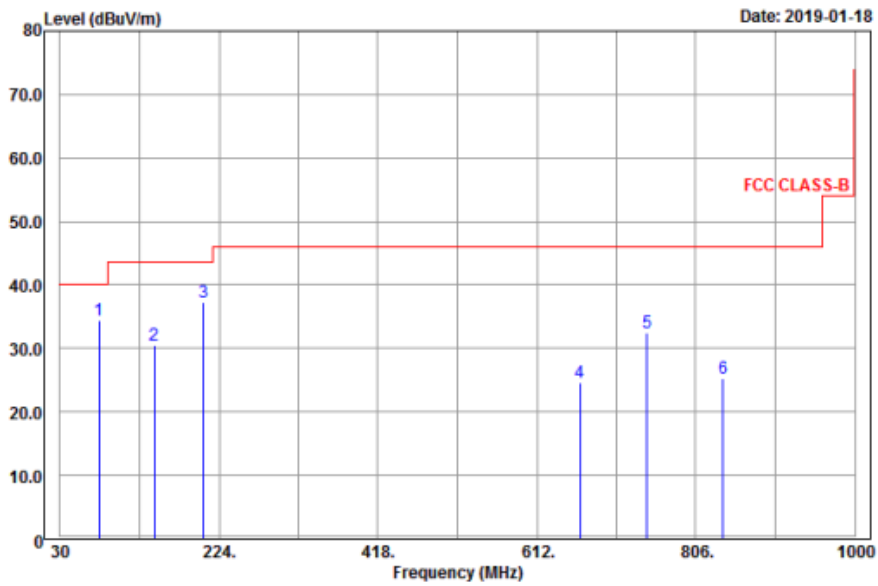

Vertical

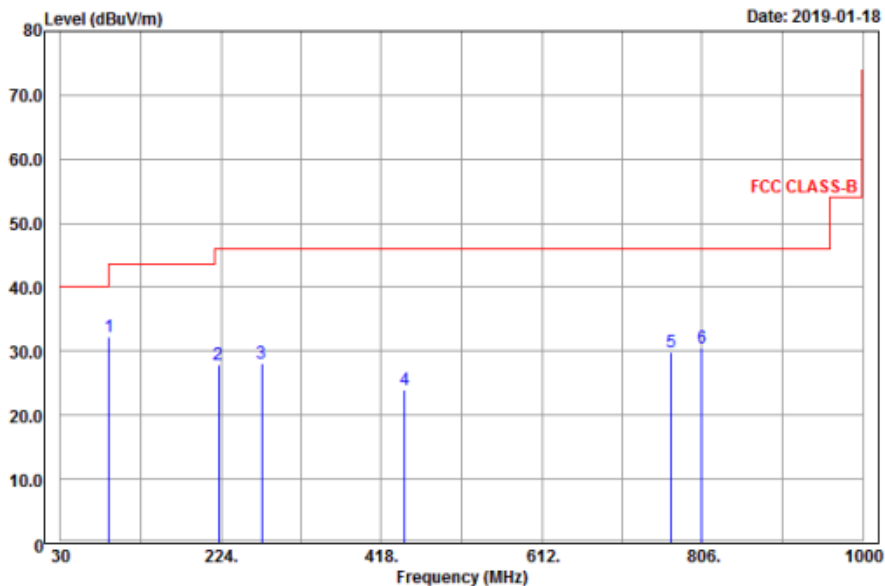

Antennal Polarity & Test Distance: Horizontal at 3 m										
Frequency (MHz)	Emission Level (dBuV/m)	Read Level (dBuV)	Limit (dBuV/m)	Margin (dB)	Antenna Factor (dB/m)	Cable Loss (dB)	Preamp Factor (dB)	Antenna Height (cm)	Table Angle (Degree)	Remark
77.52	34.46	57.24	40	-5.54	8.33	1.11	32.22	200	200	Peak
145.02	30.48	53	43.5	-13.02	8.37	1.38	32.27	134	304	Peak
205.23	37.18	56.68	43.5	-6.32	11.12	1.65	32.27	112	26	Peak
664.7	24.66	35.12	46	-21.34	18.68	2.99	32.13	124	119	Peak
746.6	32.47	41.61	46	-13.53	19.78	3.22	32.14	197	205	Peak
839.7	25.39	32.97	46	-20.61	20.89	3.38	31.85	139	3	Peak
Antennal Polarity & Test Distance: Vertical at 3 m										
Frequency (MHz)	Emission Level (dBuV/m)	Read Level (dBuV)	Limit (dBuV/m)	Margin (dB)	Antenna Factor (dB/m)	Cable Loss (dB)	Preamp Factor (dB)	Antenna Height (cm)	Table Angle (Degree)	Remark
88.32	32.19	52.94	43.5	-11.31	9.95	1.11	31.81	124	16	Peak
220.89	27.87	47.05	46	-18.13	11.38	1.65	32.21	120	259	Peak
273	28.15	45.65	46	-17.85	12.67	1.94	32.11	128	273	Peak
446.3	23.94	38.09	46	-22.06	15.51	2.49	32.15	144	219	Peak
768.3	29.84	38.73	46	-16.16	20	3.22	32.11	132	200	Peak
805.4	30.44	38.74	46	-15.56	20.41	3.32	32.03	180	25	Peak

Remarks:

- Emission Level = Read Level + Antenna Factor + Cable Loss - Preamp Factor
Margin value = Emission level – Limit value
- The emission levels of other frequencies were very low against the limit.

4.2 Conducted Emission Measurement

4.2.1 Limits of Conducted Emission Measurement

Frequency (MHz)	Conducted Limit (dBuV)	
	Quasi-Peak	Average
0.15 - 0.5	66 - 56	56 - 46
0.50 - 5.0	56	46
5.0 - 30.0	60	50

- Note: 1. The lower limit shall apply at the transition frequencies.
 2. The limit decreases in line with the logarithm of the frequency in the range of 0.15 to 0.50 MHz.

4.2.2 Test Instruments

Description & Manufacturer	Model No.	Serial No.	Date of Calibration	Due Date of Calibration
Test Receiver ROHDE & SCHWARZ	ESCI	100613	Dec. 10, 2018	Dec. 09, 2019
RF signal cable Woken	5D-FB	Cable-cond1-01	Sep. 05, 2018	Sep. 04, 2019
LISN/AMN ROHDE & SCHWARZ (EUT)	ENV216	101826	Feb. 26, 2018	Feb. 25, 2019
LISN/AMN ROHDE & SCHWARZ (Peripheral)	ESH3-Z5	100311	Aug. 19, 2018	Aug. 18, 2019
Software ADT	BV ADT_Cond_ V7.3.7.4	NA	NA	NA

- Note: 1. The calibration interval of the above test instruments is 12 months and the calibrations are traceable to NML/ROC and NIST/USA.
 2. The test was performed in HwaYa Shielded Room 1.
 3. The VCCI Site Registration No. is C-2040.

4.2.3 Test Procedures

- The EUT was placed 0.4 meters from the conducting wall of the shielded room with EUT being connected to the power mains through a line impedance stabilization network (LISN). Other support units were connected to the power mains through another LISN. The two LISNs provide 50 ohm/50 uH of coupling impedance for the measuring instrument.
- Both lines of the power mains connected to the EUT were checked for maximum conducted interference.
- The frequency range from 150 kHz to 30 MHz was searched. Emission levels under (Limit – 20 dB) was not recorded.

Note: The resolution bandwidth and video bandwidth of test receiver is 9 kHz for quasi-peak detection (QP) and average detection (AV) at frequency 0.15 MHz - 30 MHz.

4.2.4 Deviation from Test Standard

No deviation.

4.2.5 Test Setup

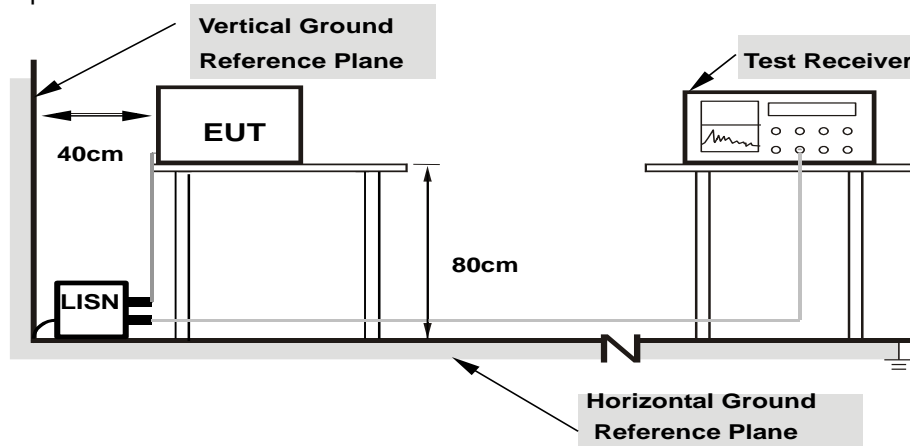

Note: 1.Support units were connected to second LISN.

2.Both of LISNs (AMN) are 80 cm from EUT and at least 80 from other units and other metal planes

4.2.6 EUT Operating Conditions

- Placed the EUT on the testing table.
- Set the EUT under transmission condition continuously at specific channel frequency.

4.2.7 Test Results

CONDUCTED WORST-CASE DATA

Mode A

Frequency Range	150kHz ~ 30MHz	Detector Function & Resolution Bandwidth	Quasi-Peak (QP) / Average (AV), 9kHz
Input Power	120Vac, 60Hz	Environmental Conditions	25°C, 65%RH
Tested by	Jisyong Wang	Test Date	2019/1/18

Phase Of Power : Line (L)										
No	Frequency (MHz)	Correction Factor (dB)	Reading Value (dBuV)		Emission Level (dBuV)		Limit (dBuV)		Margin (dB)	
			Q.P.	AV.	Q.P.	AV.	Q.P.	AV.	Q.P.	AV.
1	0.17700	10.06	37.97	13.05	48.03	23.11	64.63	54.63	-16.60	-31.52
2	0.19725	10.06	40.94	23.35	51.00	33.41	63.73	53.73	-12.73	-20.32
3	0.23550	10.06	29.16	11.72	39.22	21.78	62.25	52.25	-23.03	-30.47
4	0.25125	10.06	34.95	21.56	45.01	31.62	61.72	51.72	-16.71	-20.10
5	1.48643	10.07	18.28	4.98	28.35	15.05	56.00	46.00	-27.65	-30.95
6	13.79850	10.38	18.61	2.65	28.99	13.03	60.00	50.00	-31.01	-36.97

Remarks:

1. Q.P. and AV. are abbreviations of quasi-peak and average individually.
2. The emission levels of other frequencies were very low against the limit.
3. Margin value = Emission level – Limit value
4. Correction factor = Insertion loss + Cable loss
5. Emission Level = Correction Factor + Reading Value

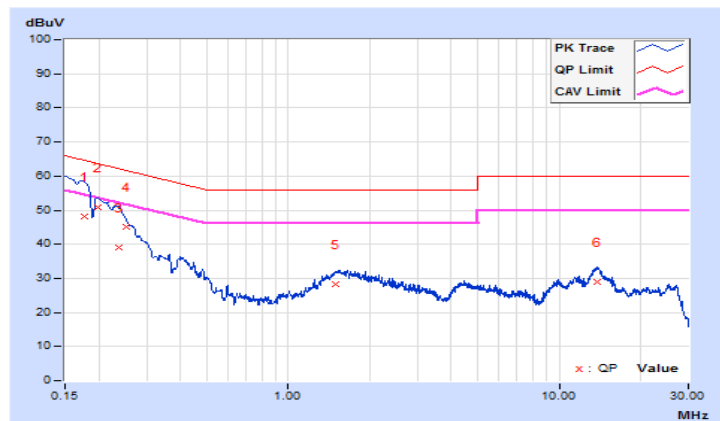

Frequency Range	150kHz ~ 30MHz	Detector Function & Resolution Bandwidth	Quasi-Peak (QP) / Average (AV), 9kHz
Input Power	120Vac, 60Hz	Environmental Conditions	25°C, 65%RH
Tested by	Jisyong Wang	Test Date	2019/1/18

Phase Of Power : Neutral (N)										
No	Frequency (MHz)	Correction Factor (dB)	Reading Value (dBuV)		Emission Level (dBuV)		Limit (dBuV)		Margin (dB)	
			Q.P.	AV.	Q.P.	AV.	Q.P.	AV.	Q.P.	AV.
1	0.16575	10.06	42.46	16.53	52.52	26.59	65.17	55.17	-12.65	-28.58
2	0.19725	10.07	39.97	24.43	50.04	34.50	63.73	53.73	-13.69	-19.23
3	0.22151	10.07	33.82	14.18	43.89	24.25	62.76	52.76	-18.87	-28.51
4	0.24900	10.07	34.24	22.39	44.31	32.46	61.79	51.79	-17.48	-19.33
5	0.41744	10.07	18.91	4.40	28.98	14.47	57.50	47.50	-28.52	-33.03
6	1.54725	10.09	22.86	5.19	32.95	15.28	56.00	46.00	-23.05	-30.72

Remarks:

1. Q.P. and AV. are abbreviations of quasi-peak and average individually.
2. The emission levels of other frequencies were very low against the limit.
3. Margin value = Emission level – Limit value
4. Correction factor = Insertion loss + Cable loss
5. Emission Level = Correction Factor + Reading Value

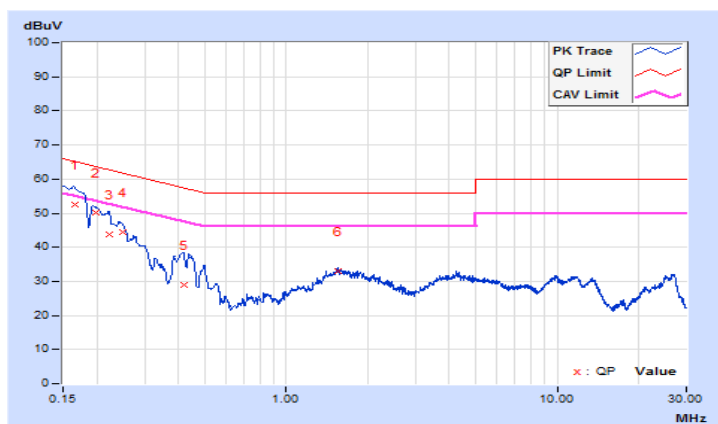

Mode B

Frequency Range	150kHz ~ 30MHz	Detector Function & Resolution Bandwidth	Quasi-Peak (QP) / Average (AV), 9kHz
Input Power	120Vac, 60Hz	Environmental Conditions	25°C, 65%RH
Tested by	Jisyong Wang	Test Date	2019/1/18

Phase Of Power : Line (L)										
No	Frequency (MHz)	Correction Factor (dB)	Reading Value (dBuV)		Emission Level (dBuV)		Limit (dBuV)		Margin (dB)	
			Q.P.	AV.	Q.P.	AV.	Q.P.	AV.	Q.P.	AV.
1	0.16567	10.05	40.85	15.11	50.90	25.16	65.17	55.17	-14.27	-30.01
2	0.18825	10.06	38.92	21.48	48.98	31.54	64.11	54.11	-15.13	-22.57
3	0.24225	10.06	31.61	15.52	41.67	25.58	62.02	52.02	-20.35	-26.44
4	0.44007	10.06	21.82	3.69	31.88	13.75	57.06	47.06	-25.18	-33.31
5	1.46850	10.07	21.43	5.19	31.50	15.26	56.00	46.00	-24.50	-30.74
6	13.61400	10.38	21.51	3.89	31.89	14.27	60.00	50.00	-28.11	-35.73

Remarks:

1. Q.P. and AV. are abbreviations of quasi-peak and average individually.
2. The emission levels of other frequencies were very low against the limit.
3. Margin value = Emission level – Limit value
4. Correction factor = Insertion loss + Cable loss
5. Emission Level = Correction Factor + Reading Value

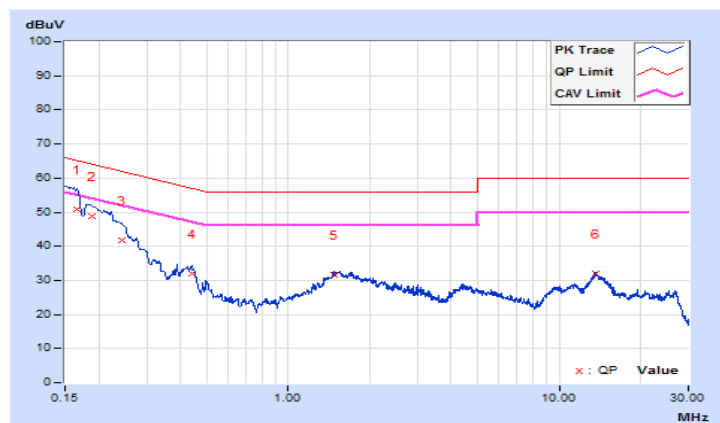

Frequency Range	150kHz ~ 30MHz	Detector Function & Resolution Bandwidth	Quasi-Peak (QP) / Average (AV), 9kHz
Input Power	120Vac, 60Hz	Environmental Conditions	25°C, 65%RH
Tested by	Jisyong Wang	Test Date	2019/1/18

Phase Of Power : Neutral (N)										
No	Frequency (MHz)	Correction Factor (dB)	Reading Value (dBuV)		Emission Level (dBuV)		Limit (dBuV)		Margin (dB)	
			Q.P.	AV.	Q.P.	AV.	Q.P.	AV.	Q.P.	AV.
1	0.16480	10.06	41.76	16.46	51.82	26.52	65.22	55.22	-13.40	-28.70
2	0.19500	10.07	39.26	22.91	49.33	32.98	63.82	53.82	-14.49	-20.84
3	0.23325	10.07	31.30	13.08	41.37	23.15	62.33	52.33	-20.96	-29.18
4	0.43350	10.07	23.52	10.57	33.59	20.64	57.19	47.19	-23.60	-26.55
5	1.60895	10.09	21.90	5.64	31.99	15.73	56.00	46.00	-24.01	-30.27
6	4.32600	10.18	21.98	5.34	32.16	15.52	56.00	46.00	-23.84	-30.48

Remarks:

1. Q.P. and AV. are abbreviations of quasi-peak and average individually.
2. The emission levels of other frequencies were very low against the limit.
3. Margin value = Emission level – Limit value
4. Correction factor = Insertion loss + Cable loss
5. Emission Level = Correction Factor + Reading Value

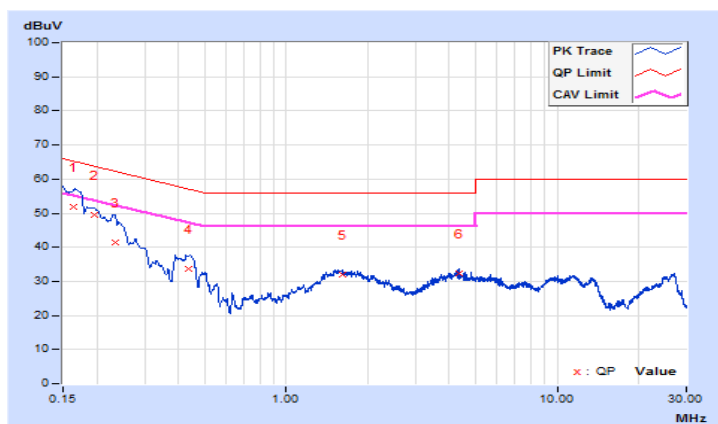

4.3 6 dB Bandwidth Measurement

4.3.1 Limits of 6 dB Bandwidth Measurement

The minimum of 6 dB Bandwidth Measurement is 0.5 MHz.

4.3.2 Test Setup



4.3.3 Test Instruments

Refer to section 4.1.2 to get information of above instrument.

4.3.4 Test Procedure

- a. Set resolution bandwidth (RBW) = 100 kHz
- b. Set the video bandwidth (VBW) $\geq 3 \times$ RBW, Detector = Peak.
- c. Trace mode = max hold.
- d. Sweep = auto couple.
- e. Measure the maximum width of the emission that is constrained by the frequencies associated with the two amplitude points (upper and lower) that are attenuated by 6 dB relative to the maximum level measured in the fundamental emission

4.3.5 Deviation from Test Standard

No deviation.

4.3.6 EUT Operating Conditions

The software provided by client to enable the EUT under transmission condition continuously at lowest, middle and highest channel frequencies individually.

4.3.7 Test Results

Channel	Frequency (MHz)	6 dB Bandwidth (MHz)	Minimum Limit (MHz)	Pass / Fail
0	2402	0.72	0.5	Pass
19	2440	0.72	0.5	Pass
39	2480	0.71	0.5	Pass

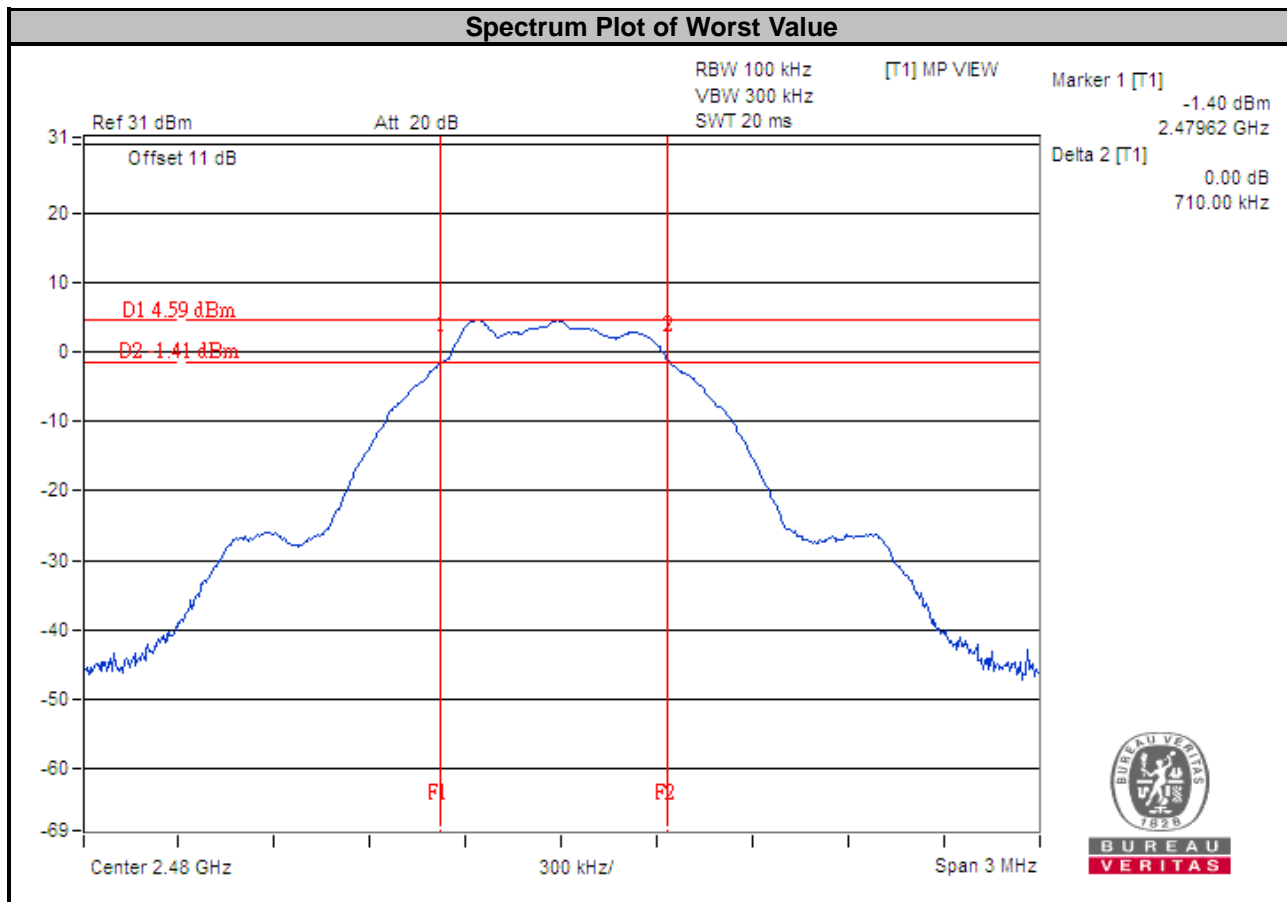

4.4 Occupied Bandwidth Measurement

4.4.1 Test Setup



4.4.2 Test Instruments

Refer to section 4.1.2 to get information of above instrument.

4.4.3 Test Procedure

The transmitter output was connected to the spectrum analyzer through an attenuator. The bandwidth of the fundamental frequency was measured by spectrum analyzer with resolution bandwidth in the range of 1 % to 5 % of the anticipated emission bandwidth, and a video bandwidth at least 3x the resolution bandwidth and set the detector to PEAK. The width of a frequency band such that, below the lower and above the upper frequency limits, the mean powers emitted are each equal to a specified percentage 0.5 % of the total mean power of a given emission.

4.4.4 Deviation from Test Standard

No deviation.

4.4.5 EUT Operating Conditions

The software provided by client to enable the EUT under transmission condition continuously at lowest, middle and highest channel frequencies individually.

4.4.6 Test Results

Channel	Frequency (MHz)	Occupied Bandwidth (MHz)	Pass / Fail
0	2402	1.03	Pass
19	2440	1.04	Pass
39	2480	1.04	Pass

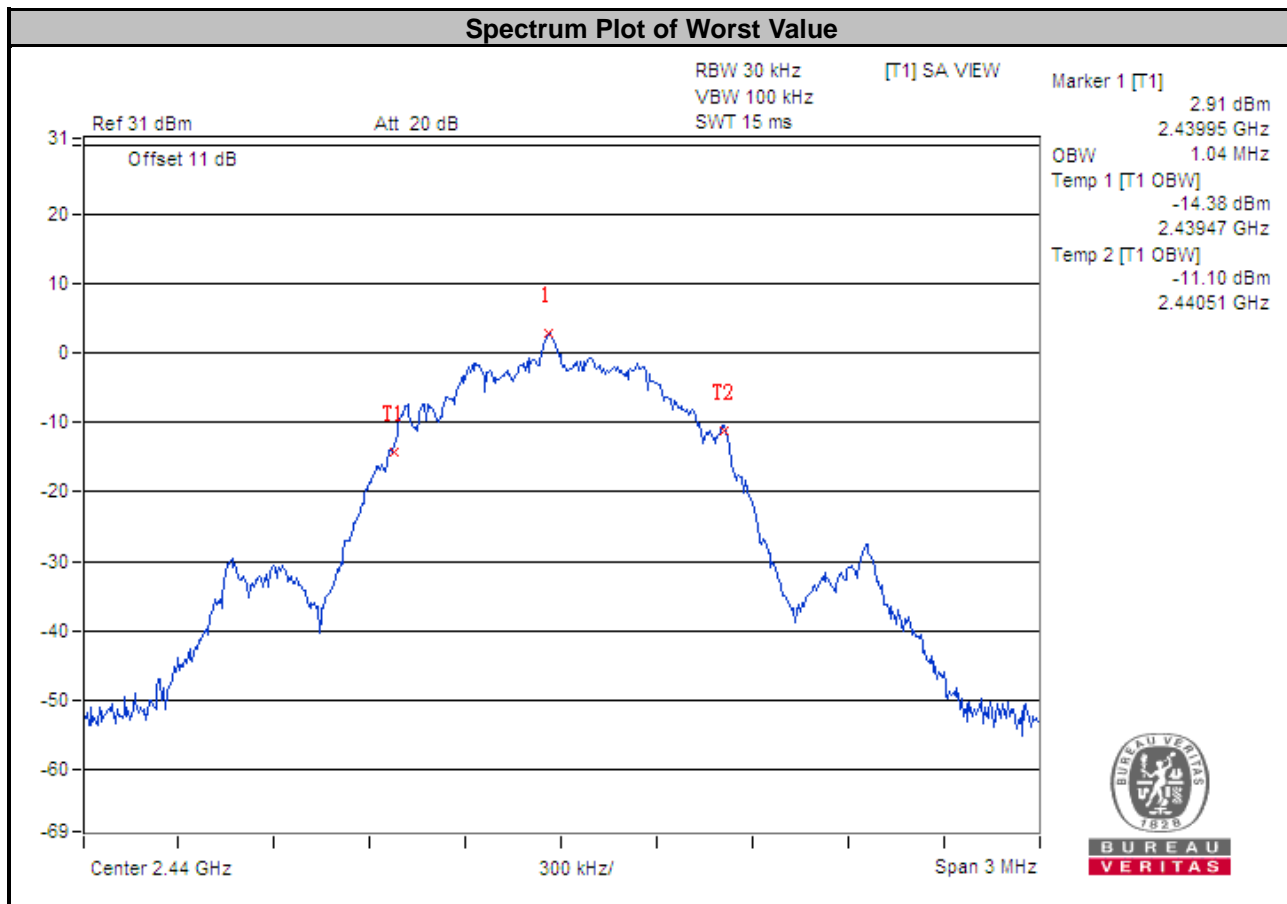

4.5 Conducted Output Power Measurement

4.5.1 Limits of Conducted Output Power Measurement

For systems using digital modulation in the 2400–2483.5 MHz bands: 1 Watt (30 dBm)

4.5.2 Test Setup

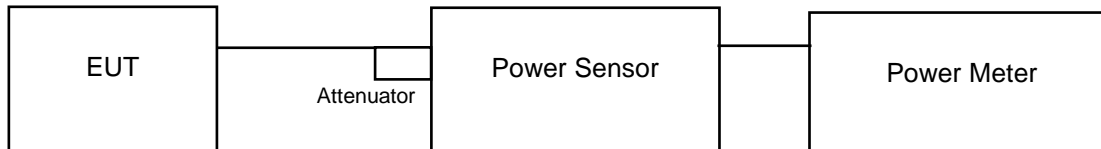

4.5.3 Test Instruments

Refer to section 4.1.2 to get information of above instrument.

4.5.4 Test Procedures

A peak power sensor was used on the output port of the EUT. A power meter was used to read the response of the peak power sensor. Record the power level.

4.5.5 Deviation from Test Standard

No deviation.

4.5.6 EUT Operating Conditions

The software provided by client to enable the EUT under transmission condition continuously at lowest, middle and highest channel frequencies individually.

4.5.7 Test Results

Channel	Frequency (MHz)	Peak Power (mW)	Peak Power (dBm)	Limit (dBm)	Pass / Fail
0	2402	2.28	3.58	30	Pass
19	2440	2.63	4.20	30	Pass
39	2480	2.28	3.58	30	Pass

4.6 Power Spectral Density Measurement

4.6.1 Limits of Power Spectral Density Measurement

The Maximum of Power Spectral Density Measurement is 8 dBm.

4.6.2 Test Setup



4.6.3 Test Instruments

Refer to section 4.1.2 to get information of above instrument.

4.6.4 Test Procedure

- a. Set analyzer center frequency to DTS channel center frequency.
- b. Set the span to 1.5 times the DTS bandwidth.
- c. Set the RBW to: $3 \text{ kHz} \leq \text{RBW} \leq 100 \text{ kHz}$.
- d. Set the VBW $\geq 3 \times \text{RBW}$.
- e. Detector = peak.
- f. Sweep time = auto couple.
- g. Trace mode = max hold.
- h. Allow trace to fully stabilize.
- i. Use the peak marker function to determine the maximum amplitude level within the RBW.

4.6.5 Deviation from Test Standard

No deviation.

4.6.6 EUT Operating Condition

The software provided by client to enable the EUT under transmission condition continuously at lowest, middle and highest channel frequencies individually.

4.6.7 Test Results

Channel	Frequency (MHz)	PSD (dBm/3 kHz)	Limit (dBm/3 kHz)	Pass / Fail
0	2402	-9.86	8	Pass
19	2440	-10.38	8	Pass
39	2480	-9.34	8	Pass

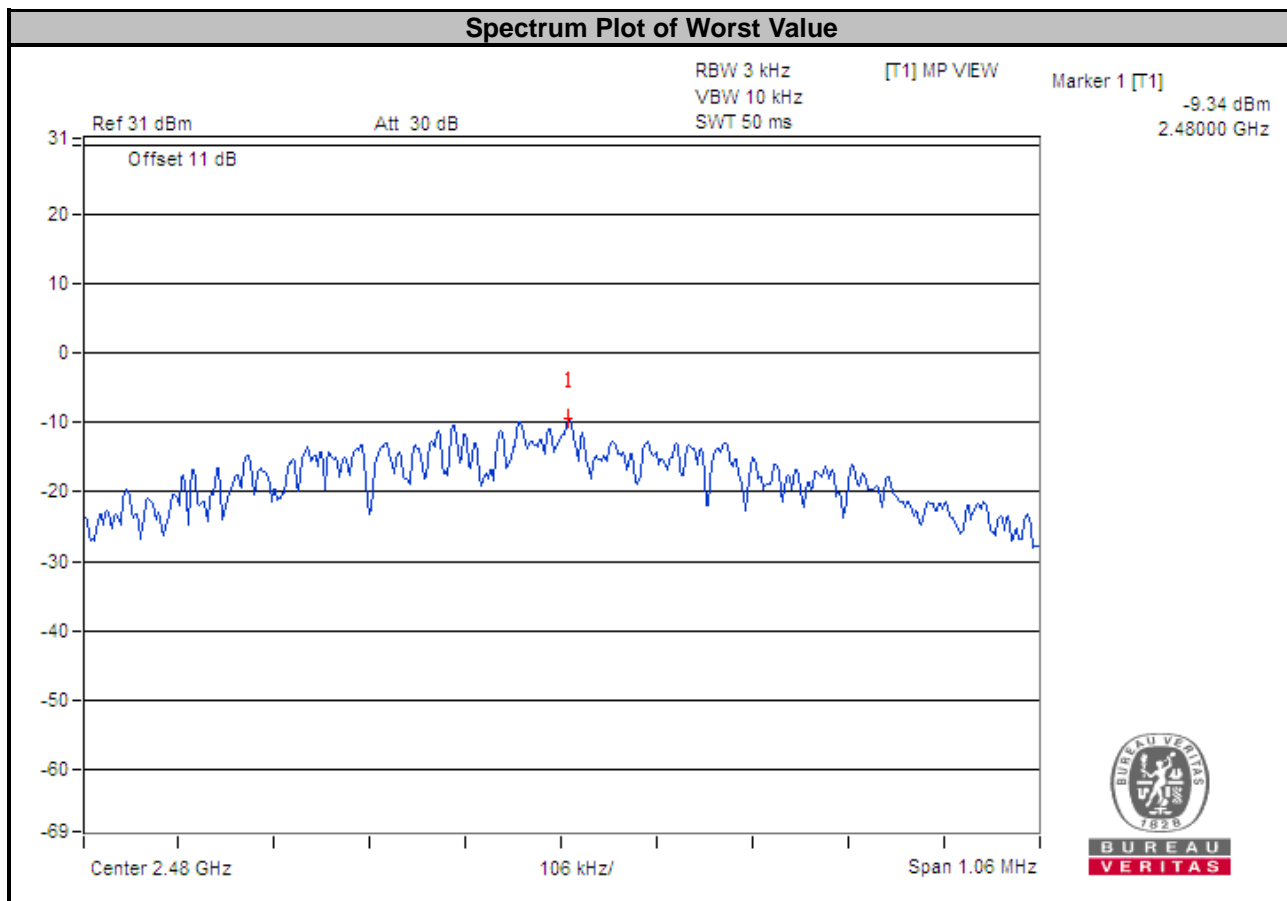

4.7 Conducted Out of Band Emission Measurement

4.7.1 Limits of Conducted Out of Band Emission Measurement

Below -20 dB of the highest emission level of operating band (in 100 kHz Resolution Bandwidth).

4.7.2 Test Setup



4.7.3 Test Instruments

Refer to section 4.1.2 to get information of above instrument.

4.7.4 Test Procedure

MEASUREMENT PROCEDURE REF

1. Set the RBW = 100 kHz.
2. Set the VBW \geq 300 kHz.
3. Detector = peak.
4. Sweep time = auto couple.
5. Trace mode = max hold.
6. Allow trace to fully stabilize.
7. Use the peak marker function to determine the maximum power level in any 100 kHz band segment within the fundamental EBW.

MEASUREMENT PROCEDURE OOB

1. Set RBW = 100 kHz.
2. Set VBW \geq 300 kHz.
3. Detector = peak.
4. Sweep = auto couple.
5. Trace Mode = max hold.
6. Allow trace to fully stabilize.
7. Use the peak marker function to determine the maximum amplitude level.

4.7.5 Deviation from Test Standard

No deviation.

4.7.6 EUT Operating Condition

The software provided by client to enable the EUT under transmission condition continuously at lowest, middle and highest channel frequencies individually.

4.7.7 Test Results

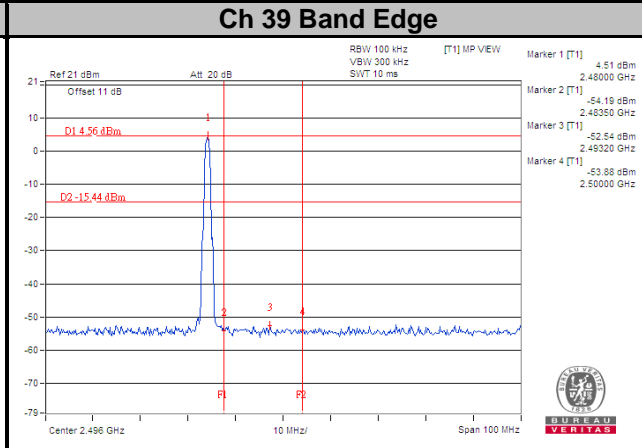
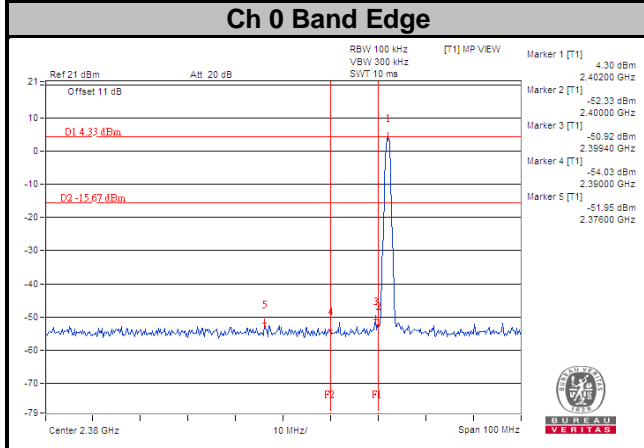
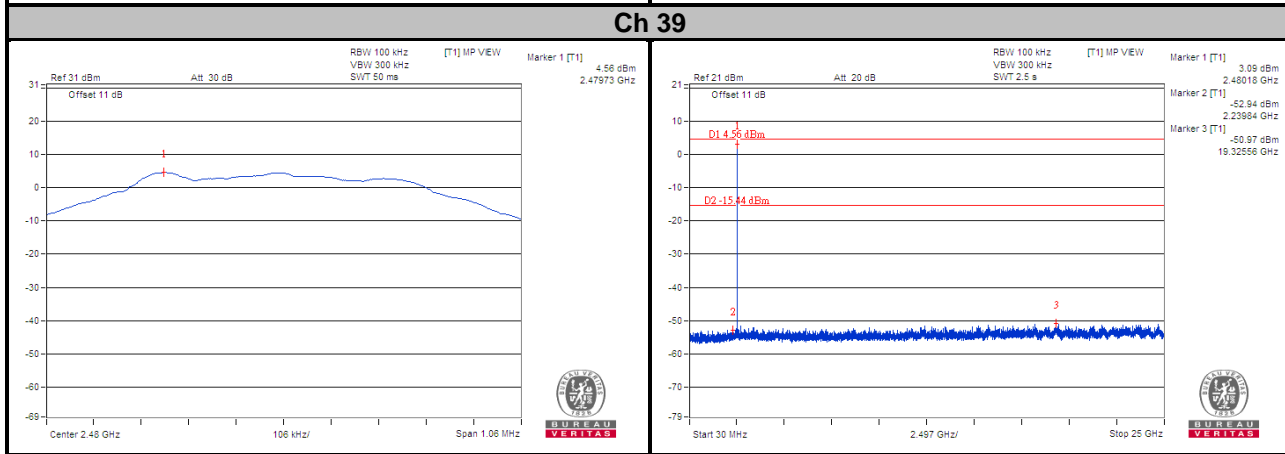
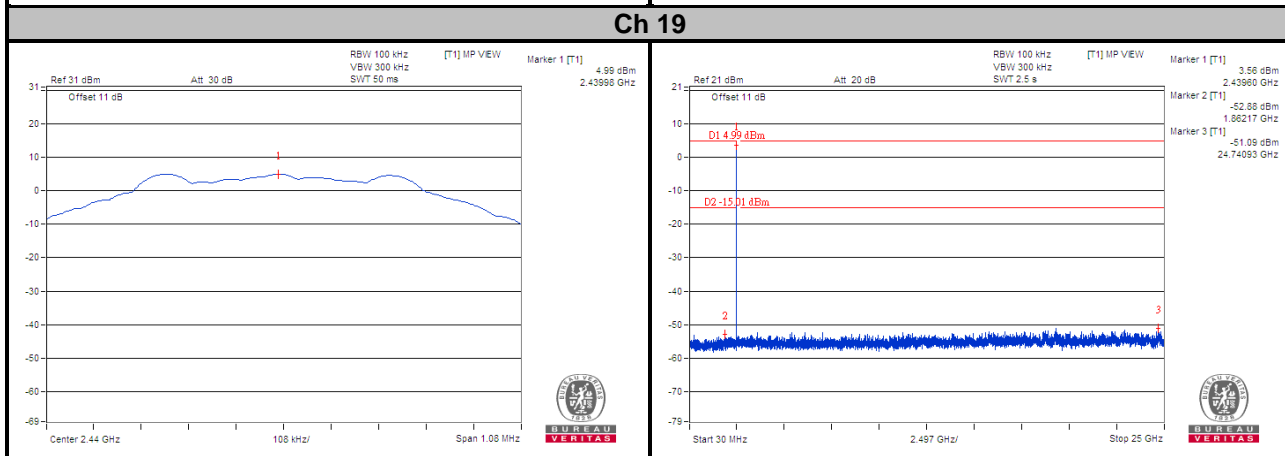
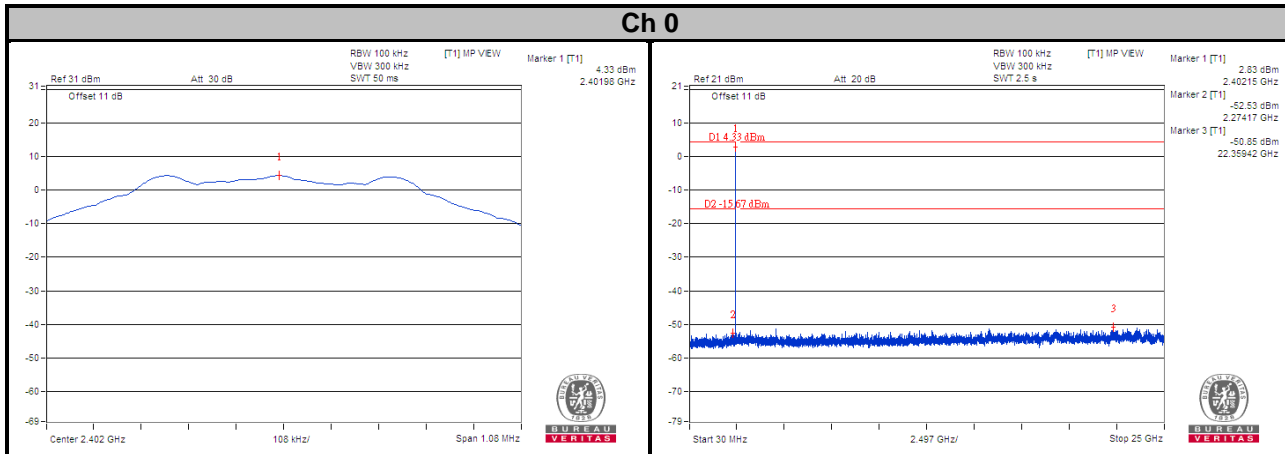

5 Pictures of Test Arrangements

Please refer to the attached file (Test Setup Photo).

Appendix – Information of the Testing Laboratories

We, Bureau Veritas Consumer Products Services (H.K.) Ltd., Taoyuan Branch, were founded in 1988 to provide our best service in EMC, Radio, Telecom and Safety consultation. Our laboratories are FCC recognized accredited test firms and accredited according to ISO/IEC 17025.

If you have any comments, please feel free to contact us at the following:

Linko EMC/RF Lab

Tel: 886-2-26052180

Fax: 886-2-26051924

Hsin Chu EMC/RF/Telecom Lab

Tel: 886-3-6668565

Fax: 886-3-6668323

Hwa Ya EMC/RF/Safety

Tel: 886-3-3183232

Fax: 886-3-3270892

Email: service.adt@tw.bureauveritas.com

Web Site: www.bureauveritas-adt.com

The address and road map of all our labs can be found in our web site also.

--- END ---