

Variant FCC Test Report

Report No.: RF131113C05D

FCC ID: W23-JWX6082

Test Model: JWX6082, JWX6083

Received Date: Apr. 19, 2017

Test Date: May 04, 2017 ~ May 07, 2017

Issued Date: May 17, 2017

Applicant: jjiPlus CORP.

Address: 13F.-3, No.120, Qiaohe Rd., Zhonghe Dist., New Taipei City 23584, Taiwan (R.O.C.)

Issued By: Bureau Veritas Consumer Products Services (H.K.) Ltd., Taoyuan Branch

Lab Address: No. 47-2, 14th Ling, Chia Pau Vil., Lin Kou Dist., New Taipei City, Taiwan (R.O.C)

Test Location (1): No.19, Hwa Ya 2nd Rd., Wen Hwa Vil., Kwei Shan Dist., Taoyuan City 33383, Taiwan, R.O.C.

Test Location (2): No.215, Sec. 3, Beixin Rd., Xindian Dist., New Taipei City 231, Taiwan, R.O.C



This report is for your exclusive use. Any copying or replication of this report to or for any other person or entity, or use of our name or trademark, is permitted only with our prior written permission. This report sets forth our findings solely with respect to the test samples identified herein. The results set forth in this report are not indicative or representative of the quality or characteristics of the lot from which a test sample was taken or any similar or identical product unless specifically and expressly noted. Our report includes all of the tests requested by you and the results thereof based upon the information that you provided to us. You have 60 days from date of issuance of this report to notify us of any material error or omission caused by our negligence, provided, however, that such notice shall be in writing and shall specifically address the issue you wish to raise. A failure to raise such issue within the prescribed time shall constitute your unqualified acceptance of the completeness of this report, the tests conducted and the correctness of the report contents. Unless specific mention, the uncertainty of measurement has been explicitly taken into account to declare the compliance or non-compliance to the specification. The report must not be used by the client to claim product certification, approval, or endorsement by TAF or any government agencies.

Table of Contents

Release Control Record	4
1 Certificate of Conformity	5
2 Summary of Test Results.....	6
2.1 Measurement Uncertainty.....	6
2.2 Modification Record	6
3 General Information	7
3.1 General Description of EUT	7
3.2 Description of Test Modes.....	8
3.2.1 Test Mode Applicability and Tested Channel Detail.....	9
3.3 Duty Cycle of Test Signal	11
3.4 Description of Support Units	12
3.4.1 Configuration of System under Test	12
3.5 General Description of Applied Standards.....	12
4 Test Types and Results	13
4.1 Radiated Emission and Bandedge Measurement	13
4.1.1 Limits of Radiated Emission and Bandedge Measurement	13
4.1.2 Limits of Unwanted Emission Out of the Restricted Bands	14
4.1.3 Test Instruments	15
4.1.4 Test Procedures.....	16
4.1.5 Deviation from Test Standard	16
4.1.6 Test Set Up	17
4.1.7 EUT Operating Conditions.....	18
4.1.8 Test Results	19
4.2 Transmit Power Measurement.....	37
4.2.1 Limits of Transmit Power Measurement	37
4.2.2 Test Setup.....	37
4.2.3 Test Instruments	38
4.2.4 Test Procedure	38
4.2.5 Deviation from Test Standard	38
4.2.6 EUT Operating Conditions.....	38
4.2.7 Test Result.....	39
4.3 Peak Power Spectral Density Measurement	45
4.3.1 Limits of Peak Power Spectral Density Measurement	45
4.3.2 Test Setup.....	45
4.3.3 Test Instruments	45
4.3.4 Test Procedures.....	45
4.3.5 Deviation from Test Standard	46
4.3.6 EUT Operating Conditions.....	46
4.3.7 Test Results	47
4.4 Frequency Stability	53
4.4.1 Limit of Frequency Stability Measurement	53
4.4.2 Test Setup.....	53
4.4.3 Test Instruments	53
4.4.4 Test Procedure	53
4.4.5 Deviation from Test Standard	53
4.4.6 EUT Operating Condition	53
4.4.7 Test Results	54
4.5 6 dB Bandwidth Measurement.....	55
4.5.1 Limits of 6 dB Bandwidth Measurement.....	55
4.5.2 Test Setup.....	55
4.5.3 Test Instruments	55
4.5.4 Test Procedure	55
4.5.5 Deviation from Test Standard	55

4.5.6 EUT Operating Condition	55
4.5.7 Test Results	56
5 Pictures of Test Arrangements.....	58
Annex A- Radiated Out of Band Emisison (OOBE) Measurement (For U-NII-3 band)	59
Appendix – Information on the Testing Laboratories	62

Release Control Record

Issue No.	Description	Date Issued
RF131113C05D	Original Release	May 17, 2017

1 Certificate of Conformity

Product: 802.11a/b/g/n 3T3R Mini-PCI Express Module

Brand: jjPlus

Test Model: JWX6082, JWX6083

Sample Status: Identical Prototype

Applicant: jjPlus CORP.

Test Date: May 04, 2017 ~ May 07, 2017

Standards: 47 CFR FCC Part 15, Subpart E (Section 15.407)
ANSI C63.10:2013

The above equipment has been tested by **Bureau Veritas Consumer Products Services (H.K.) Ltd., Taoyuan Branch**, and found compliance with the requirement of the above standards. The test record, data evaluation & Equipment Under Test (EUT) configurations represented herein are true and accurate accounts of the measurements of the sample's EMC characteristics under the conditions specified in this report.

Prepared by :

Rona Chen

, **Date:** May 17, 2017

Rona Chen / Specialist

Approved by :

David Huang

, **Date:** May 17, 2017

David Huang / Project Engineer

2 Summary of Test Results

47 CFR FCC Part 15, Subpart E (Section 15.407)			
FCC Clause	Test Item	Result	Remarks
15.407(b)(6)	AC Power Conducted Emissions	N/A	Test not applicable because of not ancillary equipment.
15.407(b) (1/2/3/4(i/ii)/6)	Radiated Emissions & Band Edge Measurement	Pass	Meet the requirement of limit. Minimum passing margin is -1.1 dB at 5150 MHz.
15.407(a)(1/2/3)	Max Average Transmit Power	Pass	Meet the requirement of limit.
15.407(a)(1/2/3)	Peak Power Spectral Density	Pass	Meet the requirement of limit.
15.407(e)	6 dB Bandwidth	Pass	Meet the requirement of limit. (U-NII-3 Band only)
15.407(g)	Frequency Stability	Pass	Meet the requirement of limit.
15.203	Antenna Requirement	Pass	No antenna connector is used.

*For U-NII-3 band compliance with rule part 15.407(b)(4)(i), the OOB test plots were recorded in Annex A.

2.1 Measurement Uncertainty

Where relevant, the following measurement uncertainty levels have been estimated for tests performed on the EUT as specified in CISPR 16-4-2:

Measurement	Frequency	Expanded Uncertainty (k=2) (±)
Conducted Emissions at mains ports	150 kHz ~ 30 MHz	2.44 dB
Radiated Emissions up to 1 GHz	30 MHz ~ 200 MHz	2.0153 dB
	200 MHz ~ 1000 MHz	2.0224 dB
Radiated Emissions above 1 GHz	1 GHz ~ 18 GHz	1.0121 dB
	18 GHz ~ 40 GHz	1.1508 dB

2.2 Modification Record

There were no modifications required for compliance.

3 General Information

3.1 General Description of EUT

Product	802.11a/b/g/n 3T3R Mini-PCI Express Module
Brand	jjPlus
Test Model	JWX6082, JWX6083
Status of EUT	Identical Prototype
Power Supply Rating	3.3 Vdc (Host equipment)
Modulation Type	64QAM, 16QAM, QPSK, BPSK
Modulation Technology	OFDM
Transfer Rate	802.11a: 54.0/ 48.0/ 36.0/ 24.0/ 18.0/ 12.0/ 9.0/ 6.0 Mbps 802.11n: up to MCS23
Operating Frequency	5180 ~ 5240 MHz, 5745 ~ 5805 MHz
Number of Channel	5180 ~ 5240 MHz: 4 for 802.11a, 802.11n (HT20) 2 for 802.11n (HT40) 5745 ~ 5805 MHz: 4 for 802.11a, 802.11n (HT20) 2 for 802.11n (HT40)
Output Power	33.976 mW for 5180 ~ 5240 MHz 81.752 mW for 5745 ~ 5805 MHz
Antenna Type	Dipole antenna with 2 dBi gain (5180 ~ 5240 MHz) Dipole antenna with 2 dBi gain (5745 ~ 5805 MHz)
Antenna Connector	N/A
Accessory Device	Refer to Note as below
Data Cable Supplied	Refer to Note as below

Note:

1. This report is issued as a supplementary report to BV CPS report no.: RF131113C05. The differences compared with original report are adding a new model and upgrading standard to the latest version. Therefore, the EUT is re-tested in this report.
2. The EUT incorporates a MIMO function. Physically, the EUT provides 3 completed transmitters and 3 receivers.

Modulation Mode	Tx Function
802.11a	1TX
802.11n (HT20)	3TX
802.11n (HT40)	3TX

3. All models are listed as below.

Brand	Model	Difference
jjPlus	JWX6082	The difference between two model names is temperature operating range only. Other specification is the same.
	JWX6083	

* JWX6082 was chosen for final test.

4. The above EUT information is declared by manufacturer and for more detailed features description, please refer to the manufacturer's specifications or user's manual.

3.2 Description of Test Modes

For 5180 ~ 5240 MHz

4 channels are provided for 802.11a, 802.11n (HT20):

Channel	Frequency (MHz)	Channel	Frequency (MHz)
36	5180	44	5220
40	5200	48	5240

2 channels are provided for 802.11n (HT40):

Channel	Frequency (MHz)	Channel	Frequency (MHz)
38	5190	46	5230

For 5745 ~ 5825 MHz:

5 channels are provided for 802.11a, 802.11n (HT20):

Channel	Frequency (MHz)	Channel	Frequency (MHz)
149	5745	157	5785
153	5765	161	5805

2 channels are provided for 802.11n (HT40):

Channel	Frequency (MHz)	Channel	Frequency (MHz)
151	5755	159	5795

3.2.1 Test Mode Applicability and Tested Channel Detail

EUT Configure Mode	Applicable To			Description
	RE \geq 1G	RE<1G	APCM	
A	√	√	√	1Tx
B	√	√	√	3Tx

Where **RE \geq 1G**: Radiated Emission above 1 GHz **RE<1G**: Radiated Emission below 1 GHz
APCM: Antenna Port Conducted Measurement

Radiated Emission Test (Above 1 GHz):

- Pre-Scan has been conducted to determine the worst-case mode from all possible combinations between available modulations, data rates and antenna ports (if EUT with antenna diversity architecture).
- Following channel(s) was (were) selected for the final test as listed below.

EUT Configure Mode	Frequency Band (MHz)	Mode	Available Channel	Tested Channel	Modulation Technology	Modulation Type	Data Rate (Mbps)
A	5180-5240	802.11a	36 to 48	36, 44, 48	OFDM	BPSK	6.0
B		802.11n (HT20)	36 to 48	36, 44, 48	OFDM	BPSK	MCS0
		802.11n (HT40)	38 to 46	38, 46	OFDM	BPSK	MCS0
A	5745-5805	802.11a	149 to 161	149, 157, 161	OFDM	BPSK	6.0
B		802.11n (HT20)	149 to 161	149, 157, 161	OFDM	BPSK	MCS0
		802.11n (HT40)	151 to 159	151, 159	OFDM	BPSK	MCS0

Radiated Emission Test (Below 1 GHz):

- Pre-Scan has been conducted to determine the worst-case mode from all possible combinations between available modulations, data rates and antenna ports (if EUT with antenna diversity architecture).
- Following channel(s) was (were) selected for the final test as listed below.

EUT Configure Mode	Frequency Band (MHz)	Mode	Available Channel	Tested Channel	Modulation Technology	Modulation Type	Data Rate (Mbps)
A	5180-5240	802.11a	36 to 48	36	OFDM	BPSK	6.0
A	5745-5805	802.11a	149 to 165	165	OFDM	BPSK	6.0

Antenna Port Conducted Measurement:

- This item includes all test value of each mode, but only includes spectrum plot of worst value of each mode.
- Pre-Scan has been conducted to determine the worst-case mode from all possible combinations between available modulations, data rates and antenna ports (if EUT with antenna diversity architecture).
- Following channel(s) was (were) selected for the final test as listed below.

EUT Configure Mode	Frequency Band (MHz)	Mode	Available Channel	Tested Channel	Modulation Technology	Modulation Type	Data Rate (Mbps)
A	5180-5240	802.11a	36 to 48	36, 44, 48	OFDM	BPSK	6.0
A, B		802.11n (HT20)	36 to 48	36, 44, 48	OFDM	BPSK	MCS0
		802.11n (HT40)	38 to 46	38, 46	OFDM	BPSK	MCS0
A	5745-5805	802.11a	149 to 161	149, 157, 161	OFDM	BPSK	6.0
A, B		802.11n (HT20)	149 to 161	149, 157, 161	OFDM	BPSK	MCS0
		802.11n (HT40)	151 to 159	151, 159	OFDM	BPSK	MCS0

Test Condition:

Applicable To	Environmental Conditions	Input Power	Tested by
RE \geq 1G	25 deg. C, 65 % RH	120 Vac, 60 Hz	Karl Lee
RE<1G	25 deg. C, 65 % RH	120 Vac, 60 Hz	Karl Lee
APCM	25 deg. C, 65 % RH	3.3 Vdc	Wayne Lin

3.3 Duty Cycle of Test Signal

MODULATION TYPE: BPSK

Mode A

802.11a: Duty cycle = $1.358/1.404 = 0.967$, Duty factor = $10 * \log(1/0.967) = 0.14$

802.11n (HT20): Duty cycle = $1.269/1.316 = 0.964$, Duty factor = $10 * \log(1/0.964) = 0.16$

802.11n (HT40): Duty cycle = $0.631/0.668 = 0.945$, Duty factor = $10 * \log(1/0.945) = 0.25$



Mode B

802.11n (HT20): Duty cycle = $0.458/0.504 = 0.909$, Duty factor = $10 * \log(1/0.909) = 0.42$

802.11n (HT40): Duty cycle = $0.247/0.280 = 0.882$, Duty factor = $10 * \log(1/0.882) = 0.54$

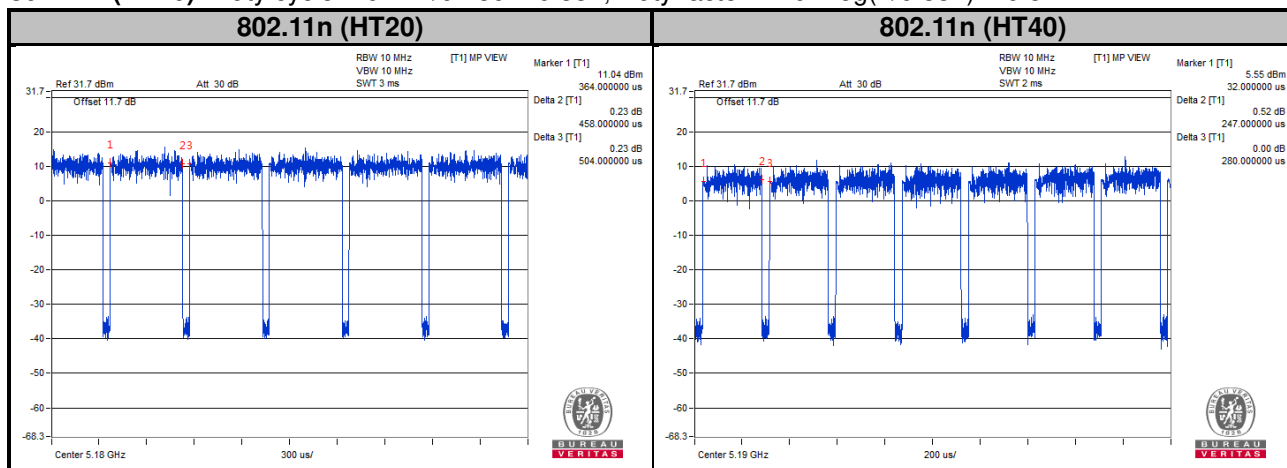

3.4 Description of Support Units

The EUT has been tested as an independent unit together with other necessary accessories or support units.

3.4.1 Configuration of System under Test

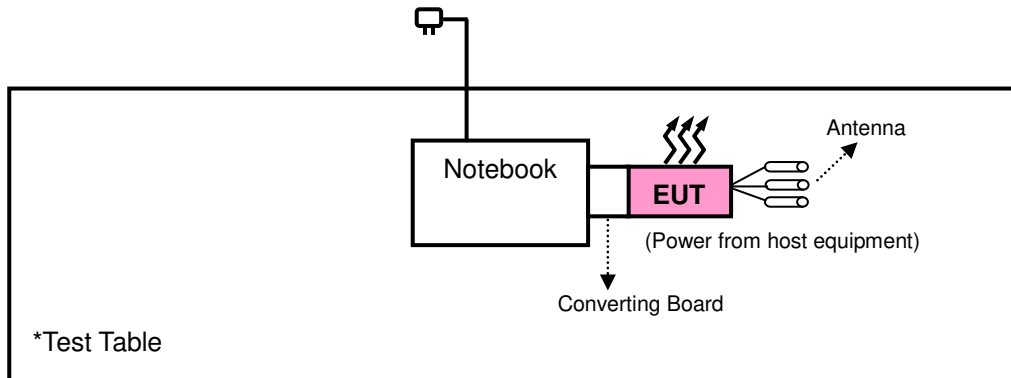

3.5 General Description of Applied Standards

The EUT is a RF Product. According to the specifications of the manufacturer, it must comply with the requirements of the following standards:

FCC Part 15, Subpart E (15.407)

789033 D02 General UNII Test Procedures New Rules v01r03

644545 D01 Guidance for IEEE 802 11ac v01r02

662911 D01 Multiple Transmitter Output v02r01

ANSI C63.10-2013

All test items have been performed and recorded as per the above standards.

Note: The EUT has been verified to comply with the requirements of FCC Part 15, Subpart B, Class B (DoC). The test report has been issued separately.

4 Test Types and Results

4.1 Radiated Emission and Bandedge Measurement

4.1.1 Limits of Radiated Emission and Bandedge Measurement

Radiated emissions which fall in the restricted bands must comply with the radiated emission limits specified as below table. Other emissions shall be at least 20 dB below the highest level of the desired power:

Frequencies (MHz)	Field Strength (microvolts/meter)	Measurement Distance (meters)
0.009 ~ 0.490	2400/F (kHz)	300
0.490 ~ 1.705	24000/F (kHz)	30
1.705 ~ 30.0	30	30
30 ~ 88	100	3
88 ~ 216	150	3
216 ~ 960	200	3
Above 960	500	3

Note:

1. The lower limit shall apply at the transition frequencies.
2. Emission level (dBuV/m) = 20 log Emission level (uV/m).
3. For frequencies above 1000 MHz, the field strength limits are based on average detector, however, the peak field strength of any emission shall not exceed the maximum permitted average limits, specified above by more than 20 dB under any condition of modulation.

4.1.2 Limits of Unwanted Emission Out of the Restricted Bands

Applicable To		Limit	
789033 D02 General UNII Test Procedures New Rules v01r03		Field Strength at 3 m	
		PK: 74 (dBμV/m)	AV: 54 (dBμV/m)
Frequency Band	Applicable To	EIRP Limit	Equivalent Field Strength at 3 m
5150~5250 MHz	15.407(b)(1)	PK: -27 (dBm/MHz)	PK: 68.2 (dBμV/m)
5250~5350 MHz	15.407(b)(2)		
5470~5725 MHz	15.407(b)(3)		
5725~5850 MHz	15.407(b)(4)(i)	PK:-27 (dBm/MHz) ^{*1} PK:10 (dBm/MHz) ^{*2} PK:15.6 (dBm/MHz) ^{*3} PK:27 (dBm/MHz) ^{*4}	PK: 68.2 (dBμV/m) ^{*1} PK:105.2 (dBμV/m) ^{*2} PK: 110.8 (dBμV/m) ^{*3} PK:122.2 (dBμV/m) ^{*4}
	15.407(b)(4)(ii)	Emission limits in section 15.247(d)	
^{*1} beyond 75 MHz or more above of the band edge. ^{*2} below the band edge increasing linearly to 10 dBm/MHz at 25 MHz above. ^{*3} below the band edge increasing linearly to a level of 15.6 dBm/MHz at 5 MHz above. ^{*4} from 5 MHz above or below the band edge increasing linearly to a level of 27 dBm/MHz at the band edge.			

Note:

The following formula is used to convert the equipment isotropic radiated power (eirp) to field strength:

$$E = \frac{1000000\sqrt{30P}}{3} \mu\text{V/m, where P is the eirp (Watts).}$$

4.1.3 Test Instruments

Description & Manufacturer	Model No.	Serial No.	Date of Calibration	Due Date of Calibration
Test Receiver Agilent Technologies	N9038A	MY52260177	Jun. 21, 2016	Jun. 20, 2017
Spectrum Analyzer ROHDE & SCHWARZ	FSU43	101261	Dec. 13, 2016	Dec. 12, 2017
BILOG Antenna SCHWARZBECK	VULB9168	9168-472	Dec. 16, 2016	Dec. 15, 2017
HORN Antenna ETS-Lindgren	3117	00143293	Dec. 29, 2016	Dec. 28, 2017
HORN Antenna SCHWARZBECK	BBHA 9170	9170-480	Dec. 14, 2016	Dec. 13, 2017
Fixed Attenuator Mini-Circuits	BW-N10W5+	NA	Jul. 08, 2016	Jul. 07, 2017
Loop Antenna	EM-6879	269	Aug. 11, 2016	Aug. 10, 2017
Preamplifier Agilent	310N	187226	Jun. 24, 2016	Jun. 23, 2017
Preamplifier Agilent	83017A	MY39501357	Jun. 24, 2016	Jun. 23, 2017
Power Meter Anritsu	ML2495A	1232002	Sep. 08, 2016	Sep. 07, 2017
Power Sensor Anritsu	MA2411B	1207325	Sep. 08, 2016	Sep. 07, 2017
RF signal cable ETS-LINDGREN	5D-FB	Cable-CH1-01(R FC-SMS-100-SM S-120+RFC-SMS -100-SMS-400)	Jun. 24, 2016	Jun. 23, 2017
RF signal cable ETS-LINDGREN	8D-FB	Cable-CH1-02(R FC-SMS-100-SM S-24)	Jun. 24, 2016	Jun. 23, 2017
Software BV ADT	E3 8.130425b	NA	NA	NA
Antenna Tower MF	NA	NA	NA	NA
Turn Table MF	NA	NA	NA	NA
Antenna Tower & Turn Table Controller MF	MF-7802	NA	NA	NA
Temperature & Humidity Chamber	GTH-120-40-CP-A R	MAA1306-019	Sep. 02, 2016	Sep. 01, 2017
DC Power Supply Topward	33010D	807748	Oct. 25, 2016	Oct. 24, 2018
Digital Multimeter Fluke	87-III	70360742	Jul. 01, 2016	Jun. 30, 2017

- Note: 1. The calibration interval of the above test instruments is 12 / 24 months and the calibrations are traceable to NML/ROC and NIST/USA.
2. The test was performed in HsinTien Chamber 1.
3. The horn antenna and preamplifier (model: 83017A) are used only for the measurement of emission frequency above 1 GHz if tested.
4. The FCC Site Registration No. is 149147.
5. The IC Site Registration No. is IC7450I-1.

4.1.4 Test Procedures

- a. The EUT was placed on the top of a rotating table 0.8 meters (for below 1 GHz) / 1.5 meters (for above 1 GHz) above the ground at 3 meter chamber room for test. The table was rotated 360 degrees to determine the position of the highest radiation.
- b. The EUT was set 3 meters away from the interference-receiving antenna, which was mounted on the top of a variable-height antenna tower.
- c. The height of antenna is varied from one meter to four meters above the ground to determine the maximum value of the field strength. Both horizontal and vertical polarizations of the antenna are set to make the measurement.
- d. For each suspected emission, the EUT was arranged to its worst case and then the antenna was tuned to heights from 1 meter to 4 meters and the rotatable table was turned from 0 degrees to 360 degrees to find the maximum reading.
- e. The test-receiver system was set to quasi-peak detect function and specified bandwidth with maximum hold mode when the test frequency is below 1 GHz.
- f. The test-receiver system was set to peak and average detected function and specified bandwidth with maximum hold mode when the test frequency is above 1 GHz. If the peak reading value also meets average limit, measurement with the average detector is unnecessary.

Note:

1. The resolution bandwidth and video bandwidth of test receiver/spectrum analyzer is 120 kHz & 360 kHz for Quasi-peak detection (QP) at frequency below 1 GHz.
2. The resolution bandwidth of test receiver/spectrum analyzer is 1 MHz and the video bandwidth is 3 MHz for Peak detection (PK) at frequency above 1 GHz.
3. The resolution bandwidth of test receiver/spectrum analyzer is 1 MHz and the video bandwidth is 1/T for RMS Average (Duty cycle < 98 %) for Peak detection at frequency above 1 GHz.
4. The resolution bandwidth of test receiver/spectrum analyzer is 1 MHz and the video bandwidth is 10 Hz (Duty cycle ≥ 98 %) for Average detection (AV) at frequency above 1 GHz.
5. All modes of operation were investigated and the worst-case emissions are reported.

4.1.5 Deviation from Test Standard

No deviation.

4.1.6 Test Set Up

<Radiated emission below 30MHz>

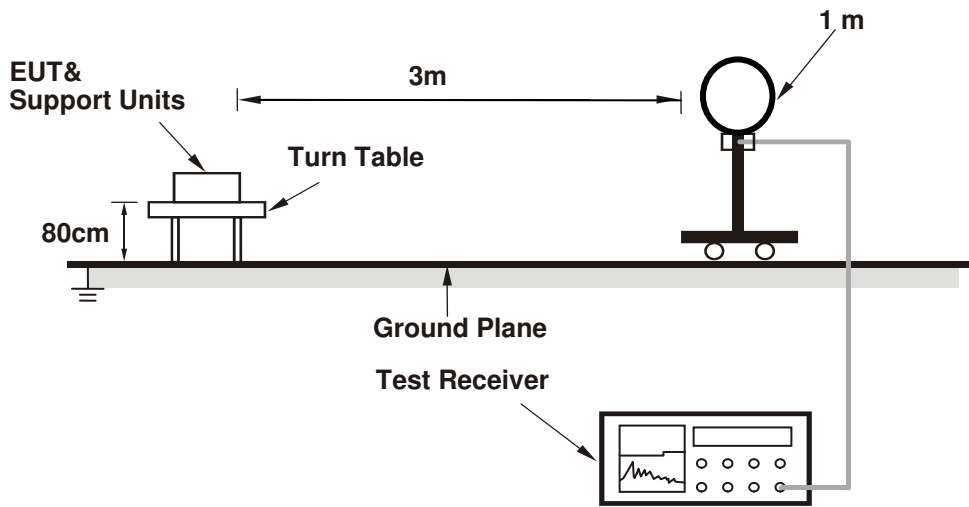

<Frequency Range below 1 GHz>

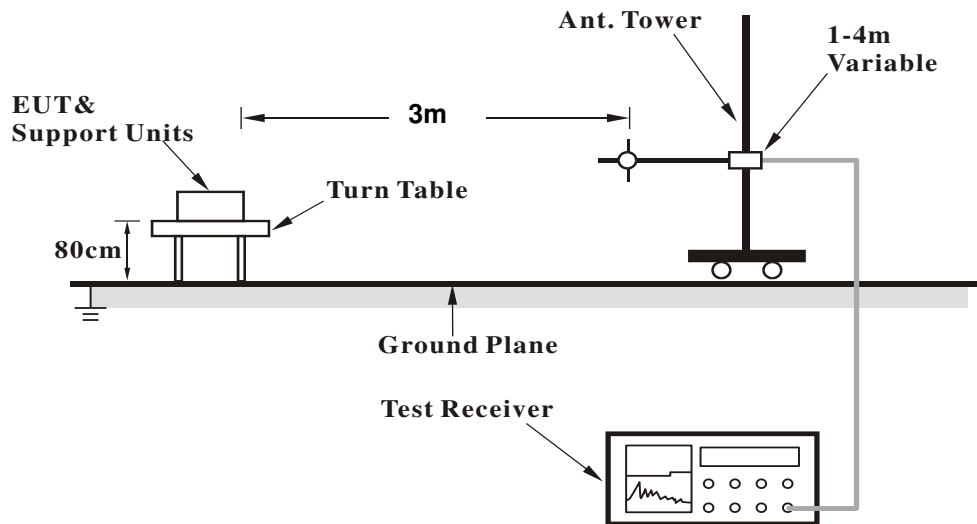

<Frequency Range above 1 GHz>

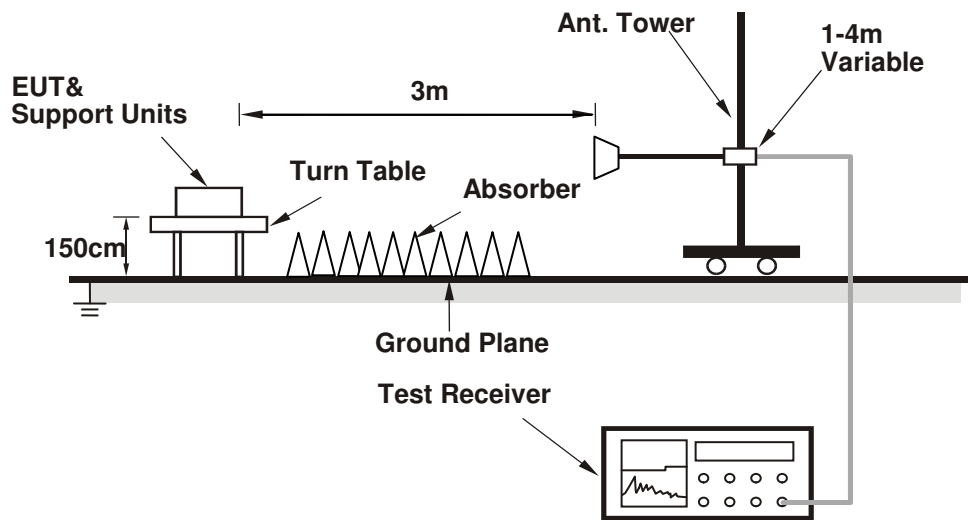

For the actual test configuration, please refer to the attached file (Test Setup Photo).

4.1.7 EUT Operating Conditions

- Placed the EUT on a testing table.
- Use the software to control the EUT under transmission condition continuously at specific channel frequency.

4.1.8 Test Results
 Above 1 GHz Data :
 Mode A
 802.11a

EUT Test Condition		Measurement Detail	
Channel	Channel 36	Frequency Range	1 GHz ~ 40 GHz
Input Power	120 Vac, 60 Hz	Detector Function	Peak (PK) Average (AV)
Environmental Conditions	25 deg. C, 65 % RH	Tested By	Karl Lee

Antenna Polarity & Test Distance: Horizontal at 3 m										
Frequency (MHz)	Emission Level (dBuV/m)	Read Level (dBuV)	Limit (dBuV/m)	Margin (dB)	Antenna Factor (dB/m)	Cable Loss (dB)	Preamp Factor (dB)	Antenna Height (cm)	Table Angle (Degree)	Remark
5145	60.66	52.41	74	-13.34	34.12	8.13	34	115	119	Peak
5148	46.77	38.52	54	-7.23	34.12	8.13	34	115	119	Average
5180	94.85	86.54			34.15	8.16	34	125	148	Average
5180	102.96	94.65			34.15	8.16	34	125	148	Peak
5434	48.82	40.03	54	-5.18	34.35	8.48	34.04	101	171	Average
5434	57.89	49.1	74	-16.11	34.35	8.48	34.04	101	171	Peak

Antenna Polarity & Test Distance: Vertical at 3 m										
Frequency (MHz)	Emission Level (dBuV/m)	Read Level (dBuV)	Limit (dBuV/m)	Margin (dB)	Antenna Factor (dB/m)	Cable Loss (dB)	Preamp Factor (dB)	Antenna Height (cm)	Table Angle (Degree)	Remark
5147.15	63.79	55.54	74	-10.21	34.12	8.13	34	101	171	Peak
5150	52.9	44.65	54	-1.1	34.12	8.13	34	101	171	Average
5180	100.85	92.54			34.15	8.16	34	101	171	Average
5180	108.96	100.65			34.15	8.16	34	101	171	Peak
5434	48.67	39.88	54	-5.33	34.35	8.48	34.04	101	171	Average
5434	57.89	49.1	74	-16.11	34.35	8.48	34.04	101	171	Peak

Remarks:

- Emission Level = Read Level + Antenna Factor + Cable Loss - Preamp Factor
 Margin value = Emission level – Limit value
- 5180 MHz: Fundamental Frequency
- *: Out of Restricted Band

EUT Test Condition		Measurement Detail	
Channel	Channel 44	Frequency Range	1 GHz ~ 40 GHz
Input Power	120 Vac, 60 Hz	Detector Function	Peak (PK) Average (AV)
Environmental Conditions	25 deg. C, 65 % RH	Tested By	Karl Lee

Antenna Polarity & Test Distance: Horizontal at 3 m										
Frequency (MHz)	Emission Level (dBuV/m)	Read Level (dBuV)	Limit (dBuV/m)	Margin (dB)	Antenna Factor (dB/m)	Cable Loss (dB)	Preamp Factor (dB)	Antenna Height (cm)	Table Angle (Degree)	Remark
5030	43.11	35.05	54	-10.89	34.03	8	33.97	131	236	Average
5030	57.98	49.92	74	-16.02	34.03	8	33.97	131	236	Peak
5220	98.21	89.82			34.17	8.22	34	131	236	Average
5220	105.89	97.5			34.17	8.22	34	131	236	Peak
5440	43.06	34.27	54	-10.94	34.35	8.48	34.04	131	236	Average
5440	57.99	49.2	74	-16.01	34.35	8.48	34.04	131	236	Peak

Antenna Polarity & Test Distance: Vertical at 3 m										
Frequency (MHz)	Emission Level (dBuV/m)	Read Level (dBuV)	Limit (dBuV/m)	Margin (dB)	Antenna Factor (dB/m)	Cable Loss (dB)	Preamp Factor (dB)	Antenna Height (cm)	Table Angle (Degree)	Remark
5142	45.05	36.79	54	-8.95	34.12	8.13	33.99	110	100	Average
5142	58.43	50.17	74	-15.57	34.12	8.13	33.99	110	100	Peak
5220	103.85	95.46			34.17	8.22	34	110	100	Average
5220	110.08	101.69			34.17	8.22	34	110	100	Peak
5376	45.23	36.57	54	-8.77	34.29	8.41	34.04	110	100	Average
5376	59.25	50.59	74	-14.75	34.29	8.41	34.04	110	100	Peak

Remarks:

- Emission Level = Read Level + Antenna Factor + Cable Loss - Preamp Factor
Margin value = Emission level – Limit value
- 5220 MHz: Fundamental Frequency
- *: Out of Restricted Band

EUT Test Condition		Measurement Detail	
Channel	Channel 48	Frequency Range	1 GHz ~ 40 GHz
Input Power	120 Vac, 60 Hz	Detector Function	Peak (PK) Average (AV)
Environmental Conditions	25 deg. C, 65 % RH	Tested By	Karl Lee

Antenna Polarity & Test Distance: Horizontal at 3 m										
Frequency (MHz)	Emission Level (dBuV/m)	Read Level (dBuV)	Limit (dBuV/m)	Margin (dB)	Antenna Factor (dB/m)	Cable Loss (dB)	Preamp Factor (dB)	Antenna Height (cm)	Table Angle (Degree)	Remark
5024	42.79	34.76	54	-11.21	34.03	7.97	33.97	129	235	Average
5024	56.82	48.79	74	-17.18	34.03	7.97	33.97	129	235	Peak
5240	97.56	89.12			34.19	8.26	34.01	129	235	Average
5240	105.3	96.86			34.19	8.26	34.01	129	235	Peak
5368	43.16	34.49	54	-10.84	34.29	8.41	34.03	129	235	Average
5368	57.29	48.62	74	-16.71	34.29	8.41	34.03	129	235	Peak

Antenna Polarity & Test Distance: Vertical at 3 m										
Frequency (MHz)	Emission Level (dBuV/m)	Read Level (dBuV)	Limit (dBuV/m)	Margin (dB)	Antenna Factor (dB/m)	Cable Loss (dB)	Preamp Factor (dB)	Antenna Height (cm)	Table Angle (Degree)	Remark
5116	44.34	36.14	54	-9.66	34.09	8.1	33.99	108	110	Average
5116	58.09	49.89	74	-15.91	34.09	8.1	33.99	108	110	Peak
5240	102.97	94.53			34.19	8.26	34.01	108	110	Average
5240	109.48	101.04			34.19	8.26	34.01	108	110	Peak
5374	43.92	35.26	54	-10.08	34.29	8.41	34.04	108	110	Average
5374	58.47	49.81	74	-15.53	34.29	8.41	34.04	108	110	Peak

Remarks:

- Emission Level = Read Level + Antenna Factor + Cable Loss - Preamp Factor
Margin value = Emission level – Limit value
- 5240 MHz: Fundamental Frequency
- *: Out of Restricted Band

EUT Test Condition		Measurement Detail	
Channel	Channel 149	Frequency Range	1 GHz ~ 40 GHz
Input Power	120 Vac, 60 Hz	Detector Function	Peak (PK) Average (AV)
Environmental Conditions	25 deg. C, 65 % RH	Tested By	Karl Lee

<Spurious Emission>

Antenna Polarity & Test Distance: Horizontal at 3 m										
Frequency (MHz)	Emission Level (dBuV/m)	Read Level (dBuV)	Limit (dBuV/m)	Margin (dB)	Antenna Factor (dB/m)	Cable Loss (dB)	Preamp Factor (dB)	Antenna Height (cm)	Table Angle (Degree)	Remark
5745	92.24	83.05			34.64	8.66	34.11	100	37	Average
5745	99.53	90.34			34.64	8.66	34.11	100	37	Peak
11490	46.72	31.6	54	-7.28	37.89	12.62	35.39	138	224	Average
11490	55.07	39.95	74	-18.93	37.89	12.62	35.39	138	224	Peak
Antenna Polarity & Test Distance: Vertical at 3 m										
Frequency (MHz)	Emission Level (dBuV/m)	Read Level (dBuV)	Limit (dBuV/m)	Margin (dB)	Antenna Factor (dB/m)	Cable Loss (dB)	Preamp Factor (dB)	Antenna Height (cm)	Table Angle (Degree)	Remark
5745	101.61	92.42			34.64	8.66	34.11	101	7	Average
5745	108.31	99.12			34.64	8.66	34.11	101	7	Peak
11490	46.82	31.7	54	-7.18	37.89	12.62	35.39	147	124	Average
11490	55.22	40.1	74	-18.78	37.89	12.62	35.39	147	124	Peak

<Out of Band Emission (OOBE)>

Antenna Polarity & Test Distance: Horizontal at 3 m										
Frequency (MHz)	Emission Level (dBuV/m)	Read Level (dBuV)	Limit (dBuV/m)	Margin (dB)	Antenna Factor (dB/m)	Cable Loss (dB)	Preamp Factor (dB)	Antenna Height (cm)	Table Angle (Degree)	Remark
*5566.675	43.28	34.29	54	-10.72	34.47	8.59	34.07	100	37	Average
*5566.675	53.63	44.64	74	-20.37	34.47	8.59	34.07	100	37	Peak
5651.2	53	43.91	74.75	-21.75	34.56	8.62	34.09	100	37	Peak
5920	52.78	43.4	77.12	-24.34	34.81	8.73	34.16	100	37	Peak
*5985.625	44.56	35.1	54	-9.44	34.88	8.75	34.17	100	37	Average
*5985.625	54.61	45.15	74	-19.39	34.88	8.75	34.17	100	37	Peak
Antenna Polarity & Test Distance: Vertical at 3 m										
Frequency (MHz)	Emission Level (dBuV/m)	Read Level (dBuV)	Limit (dBuV/m)	Margin (dB)	Antenna Factor (dB/m)	Cable Loss (dB)	Preamp Factor (dB)	Antenna Height (cm)	Table Angle (Degree)	Remark
*5637.025	43.31	34.24	54	-10.69	34.54	8.62	34.09	101	7	Average
*5637.025	53.92	44.85	74	-20.08	34.54	8.62	34.09	101	7	Peak
5653.825	52.89	43.8	76.39	-23.5	34.56	8.63	34.1	101	7	Peak
5920	52.46	43.08	77.12	-24.66	34.81	8.73	34.16	101	7	Peak
*6000.85	43.24	33.75	54	-10.76	34.9	8.76	34.17	101	7	Average
*6000.85	53.24	43.75	74	-20.76	34.9	8.76	34.17	101	7	Peak

Remarks:

- Emission Level = Read Level + Antenna Factor + Cable Loss - Preamp Factor
Margin value = Emission level – Limit value
- 5745 MHz: Fundamental Frequency
- *: Out of Restricted Band

EUT Test Condition		Measurement Detail	
Channel	Channel 157	Frequency Range	1 GHz ~ 40 GHz
Input Power	120 Vac, 60 Hz	Detector Function	Peak (PK) Average (AV)
Environmental Conditions	25 deg. C, 65 % RH	Tested By	Karl Lee

<Spurious Emission>

Antenna Polarity & Test Distance: Horizontal at 3 m										
Frequency (MHz)	Emission Level (dBuV/m)	Read Level (dBuV)	Limit (dBuV/m)	Margin (dB)	Antenna Factor (dB/m)	Cable Loss (dB)	Preamp Factor (dB)	Antenna Height (cm)	Table Angle (Degree)	Remark
5785	91.77	82.54			34.68	8.68	34.13	112	37	Average
5785	99.52	90.29			34.68	8.68	34.13	112	37	Peak
11570	47.18	31.87	54	-6.82	38	12.68	35.37	108	153	Average
11570	56.33	41.02	74	-17.67	38	12.68	35.37	108	153	Peak
Antenna Polarity & Test Distance: Vertical at 3 m										
Frequency (MHz)	Emission Level (dBuV/m)	Read Level (dBuV)	Limit (dBuV/m)	Margin (dB)	Antenna Factor (dB/m)	Cable Loss (dB)	Preamp Factor (dB)	Antenna Height (cm)	Table Angle (Degree)	Remark
5785	101.24	92.01			34.68	8.68	34.13	101	7	Average
5785	108.93	99.7			34.68	8.68	34.13	101	7	Peak
11570	46.82	31.51	54	-7.18	38	12.68	35.37	154	287	Average
11570	55.56	40.25	74	-18.44	38	12.68	35.37	154	287	Peak

<Out of Band Emission (OOBE)>

Antenna Polarity & Test Distance: Horizontal at 3 m										
Frequency (MHz)	Emission Level (dBuV/m)	Read Level (dBuV)	Limit (dBuV/m)	Margin (dB)	Antenna Factor (dB/m)	Cable Loss (dB)	Preamp Factor (dB)	Antenna Height (cm)	Table Angle (Degree)	Remark
*5585.05	42.74	33.73	54	-11.26	34.49	8.6	34.08	112	37	Average
*5585.05	53.71	44.7	74	-20.29	34.49	8.6	34.08	112	37	Peak
5652.25	52.81	43.72	75.4	-22.59	34.56	8.62	34.09	112	37	Peak
5920	52.35	42.97	77.12	-24.77	34.81	8.73	34.16	112	37	Peak
*5985.625	43.44	33.98	54	-10.56	34.88	8.75	34.17	112	37	Average
*5985.625	53.92	44.46	74	-20.08	34.88	8.75	34.17	112	37	Peak
Antenna Polarity & Test Distance: Vertical at 3 m										
Frequency (MHz)	Emission Level (dBuV/m)	Read Level (dBuV)	Limit (dBuV/m)	Margin (dB)	Antenna Factor (dB/m)	Cable Loss (dB)	Preamp Factor (dB)	Antenna Height (cm)	Table Angle (Degree)	Remark
*5528.35	42.85	33.92	54	-11.15	34.42	8.58	34.07	101	7	Average
*5528.35	54.2	45.27	74	-19.8	34.42	8.58	34.07	101	7	Peak
5652.775	53.19	44.09	75.73	-22.54	34.56	8.63	34.09	101	7	Peak
5922.625	52.74	43.34	75.48	-22.74	34.83	8.73	34.16	101	7	Peak
*6008.725	43.64	34.13	54	-10.36	34.92	8.76	34.17	101	7	Average
*6008.725	55.54	46.03	74	-18.46	34.92	8.76	34.17	101	7	Peak

Remarks:

- Emission Level = Read Level + Antenna Factor + Cable Loss - Preamp Factor
Margin value = Emission level – Limit value
- 5785 MHz: Fundamental Frequency
- *: Out of Restricted Band

EUT Test Condition		Measurement Detail	
Channel	Channel 161	Frequency Range	1 GHz ~ 40 GHz
Input Power	120 Vac, 60 Hz	Detector Function	Peak (PK) Average (AV)
Environmental Conditions	25 deg. C, 65 % RH	Tested By	Karl Lee

<Spurious Emission>

Antenna Polarity & Test Distance: Horizontal at 3 m										
Frequency (MHz)	Emission Level (dBuV/m)	Read Level (dBuV)	Limit (dBuV/m)	Margin (dB)	Antenna Factor (dB/m)	Cable Loss (dB)	Preamp Factor (dB)	Antenna Height (cm)	Table Angle (Degree)	Remark
5805	92.04	82.78			34.71	8.68	34.13	105	37	Average
5805	99.36	90.1			34.71	8.68	34.13	105	37	Peak
11650	49.27	33.74	54	-4.73	38.09	12.8	35.36	174	127	Average
11650	58.11	42.58	74	-15.89	38.09	12.8	35.36	174	127	Peak
Antenna Polarity & Test Distance: Vertical at 3 m										
Frequency (MHz)	Emission Level (dBuV/m)	Read Level (dBuV)	Limit (dBuV/m)	Margin (dB)	Antenna Factor (dB/m)	Cable Loss (dB)	Preamp Factor (dB)	Antenna Height (cm)	Table Angle (Degree)	Remark
5805	101.72	92.46			34.71	8.68	34.13	101	2	Average
5805	108.99	99.73			34.71	8.68	34.13	101	2	Peak
11650	47.28	31.75	54	-6.72	38.09	12.8	35.36	148	243	Average
11650	56.67	41.14	74	-17.33	38.09	12.8	35.36	148	243	Peak

<Out of Band Emission (OOBE)>

Antenna Polarity & Test Distance: Horizontal at 3 m										
Frequency (MHz)	Emission Level (dBuV/m)	Read Level (dBuV)	Limit (dBuV/m)	Margin (dB)	Antenna Factor (dB/m)	Cable Loss (dB)	Preamp Factor (dB)	Antenna Height (cm)	Table Angle (Degree)	Remark
*5548.3	42.72	33.76	54	-11.28	34.45	8.58	34.07	105	37	Average
*5548.3	53.9	44.94	74	-20.1	34.45	8.58	34.07	105	37	Peak
5652.25	52.94	43.85	75.4	-22.46	34.56	8.62	34.09	105	37	Peak
5920	52.89	43.51	77.12	-24.23	34.81	8.73	34.16	105	37	Peak
*6004	43.62	34.13	54	-10.38	34.9	8.76	34.17	105	37	Average
*6004	53.61	44.12	74	-20.39	34.9	8.76	34.17	105	37	Peak
Antenna Polarity & Test Distance: Vertical at 3 m										
Frequency (MHz)	Emission Level (dBuV/m)	Read Level (dBuV)	Limit (dBuV/m)	Margin (dB)	Antenna Factor (dB/m)	Cable Loss (dB)	Preamp Factor (dB)	Antenna Height (cm)	Table Angle (Degree)	Remark
*5523.625	43.22	34.28	54	-10.78	34.42	8.58	34.06	101	2	Average
*5523.625	54.42	45.48	74	-19.58	34.42	8.58	34.06	101	2	Peak
5655.4	53.52	44.43	77.37	-23.85	34.56	8.63	34.1	101	2	Peak
5922.625	52.38	42.98	75.48	-23.1	34.83	8.73	34.16	101	2	Peak
*5973.025	43.61	34.15	54	-10.39	34.88	8.75	34.17	101	2	Average
*5973.025	54.11	44.65	74	-19.89	34.88	8.75	34.17	101	2	Peak

Remarks:

- Emission Level = Read Level + Antenna Factor + Cable Loss - Preamp Factor
Margin value = Emission level – Limit value
- 5805 MHz: Fundamental Frequency
- *: Out of Restricted Band

Mode B
802.11n (HT20)

EUT Test Condition		Measurement Detail	
Channel	Channel 36	Frequency Range	1 GHz ~ 40 GHz
Input Power	120 Vac, 60 Hz	Detector Function	Peak (PK) Average (AV)
Environmental Conditions	25 deg. C, 65 % RH	Tested By	Karl Lee

Antenna Polarity & Test Distance: Horizontal at 3 m										
Frequency (MHz)	Emission Level (dBuV/m)	Read Level (dBuV)	Limit (dBuV/m)	Margin (dB)	Antenna Factor (dB/m)	Cable Loss (dB)	Preamp Factor (dB)	Antenna Height (cm)	Table Angle (Degree)	Remark
5096	44.09	35.93	54	-9.91	34.08	8.07	33.99	112	287	Average
5096	63.62	55.46	74	-10.38	34.08	8.07	33.99	112	287	Peak
5180	95.81	87.5			34.15	8.16	34	112	287	Average
5180	104.18	95.87			34.15	8.16	34	112	287	Peak
5402	43.16	34.44	54	-10.84	34.32	8.44	34.04	112	287	Average
5402	64.14	55.42	74	-9.86	34.32	8.44	34.04	112	287	Peak

Antenna Polarity & Test Distance: Vertical at 3 m										
Frequency (MHz)	Emission Level (dBuV/m)	Read Level (dBuV)	Limit (dBuV/m)	Margin (dB)	Antenna Factor (dB/m)	Cable Loss (dB)	Preamp Factor (dB)	Antenna Height (cm)	Table Angle (Degree)	Remark
5150	51.64	43.39	54	-2.36	34.12	8.13	34	126	38	Average
5150	66.66	58.41	74	-7.34	34.12	8.13	34	126	38	Peak
5180	105.3	96.99			34.15	8.16	34	126	100	Average
5180	112.92	104.61			34.15	8.16	34	126	100	Peak
5428	46.42	37.65	54	-7.58	34.33	8.48	34.04	126	100	Average
5428	64.06	55.29	74	-9.94	34.33	8.48	34.04	126	100	Peak

Remarks:

- Emission Level = Read Level + Antenna Factor + Cable Loss - Preamp Factor
Margin value = Emission level – Limit value
- 5180 MHz: Fundamental Frequency
- *: Out of Restricted Band

EUT Test Condition		Measurement Detail	
Channel	Channel 44	Frequency Range	1 GHz ~ 40 GHz
Input Power	120 Vac, 60 Hz	Detector Function	Peak (PK) Average (AV)
Environmental Conditions	25 deg. C, 65 % RH	Tested By	Karl Lee

Antenna Polarity & Test Distance: Horizontal at 3 m										
Frequency (MHz)	Emission Level (dBuV/m)	Read Level (dBuV)	Limit (dBuV/m)	Margin (dB)	Antenna Factor (dB/m)	Cable Loss (dB)	Preamp Factor (dB)	Antenna Height (cm)	Table Angle (Degree)	Remark
5112	43.44	35.24	54	-10.56	34.09	8.1	33.99	160	288	Average
5112	63.49	55.29	74	-10.51	34.09	8.1	33.99	160	288	Peak
5220	94.2	85.81			34.17	8.22	34	160	288	Average
5220	101.93	93.54			34.17	8.22	34	160	288	Peak
5366	43.88	35.24	54	-10.12	34.29	8.38	34.03	160	288	Average
5366	64.28	55.64	74	-9.72	34.29	8.38	34.03	160	288	Peak

Antenna Polarity & Test Distance: Vertical at 3 m										
Frequency (MHz)	Emission Level (dBuV/m)	Read Level (dBuV)	Limit (dBuV/m)	Margin (dB)	Antenna Factor (dB/m)	Cable Loss (dB)	Preamp Factor (dB)	Antenna Height (cm)	Table Angle (Degree)	Remark
5128	47.1	38.88	54	-6.9	34.11	8.1	33.99	126	100	Average
5128	63.45	55.23	74	-10.55	34.11	8.1	33.99	126	100	Peak
5220	104.38	95.99			34.17	8.22	34	126	100	Average
5220	111.3	102.91			34.17	8.22	34	126	100	Peak
5422	46.86	38.09	54	-7.14	34.33	8.48	34.04	126	100	Average
5422	64.21	55.44	74	-9.79	34.33	8.48	34.04	126	100	Peak

Remarks:

- Emission Level = Read Level + Antenna Factor + Cable Loss - Preamp Factor
Margin value = Emission level – Limit value
- 5220 MHz: Fundamental Frequency
- *: Out of Restricted Band

EUT Test Condition		Measurement Detail	
Channel	Channel 48	Frequency Range	1 GHz ~ 40 GHz
Input Power	120 Vac, 60 Hz	Detector Function	Peak (PK) Average (AV)
Environmental Conditions	25 deg. C, 65 % RH	Tested By	Karl Lee

Antenna Polarity & Test Distance: Horizontal at 3 m										
Frequency (MHz)	Emission Level (dBuV/m)	Read Level (dBuV)	Limit (dBuV/m)	Margin (dB)	Antenna Factor (dB/m)	Cable Loss (dB)	Preamp Factor (dB)	Antenna Height (cm)	Table Angle (Degree)	Remark
5148	43.09	34.84	54	-10.91	34.12	8.13	34	112	287	Average
5148	64.1	55.85	74	-9.9	34.12	8.13	34	112	287	Peak
5240	93.98	85.54			34.19	8.26	34.01	112	287	Average
5240	101.36	92.92			34.19	8.26	34.01	112	287	Peak
5456	43.21	34.39	54	-10.79	34.36	8.51	34.05	112	287	Average
5456	64.03	55.21	74	-9.97	34.36	8.51	34.05	112	287	Peak

Antenna Polarity & Test Distance: Vertical at 3 m										
Frequency (MHz)	Emission Level (dBuV/m)	Read Level (dBuV)	Limit (dBuV/m)	Margin (dB)	Antenna Factor (dB/m)	Cable Loss (dB)	Preamp Factor (dB)	Antenna Height (cm)	Table Angle (Degree)	Remark
5134	44.68	36.43	54	-9.32	34.11	8.13	33.99	124	42	Average
5134	63.24	54.99	74	-10.76	34.11	8.13	33.99	124	42	Peak
5240	104	95.56			34.19	8.26	34.01	124	42	Average
5240	111.06	102.62			34.19	8.26	34.01	124	42	Peak
5416	44.73	36	54	-9.27	34.33	8.44	34.04	124	42	Average
5416	63.72	54.99	74	-10.28	34.33	8.44	34.04	124	42	Peak

Remarks:

- Emission Level = Read Level + Antenna Factor + Cable Loss - Preamp Factor
Margin value = Emission level – Limit value
- 5240 MHz: Fundamental Frequency
- *: Out of Restricted Band

EUT Test Condition		Measurement Detail	
Channel	Channel 149	Frequency Range	1 GHz ~ 40 GHz
Input Power	120 Vac, 60 Hz	Detector Function	Peak (PK) Average (AV)
Environmental Conditions	25 deg. C, 65 % RH	Tested By	Karl Lee

<Spurious Emission>

Antenna Polarity & Test Distance: Horizontal at 3 m										
Frequency (MHz)	Emission Level (dBuV/m)	Read Level (dBuV)	Limit (dBuV/m)	Margin (dB)	Antenna Factor (dB/m)	Cable Loss (dB)	Preamp Factor (dB)	Antenna Height (cm)	Table Angle (Degree)	Remark
5745	93.9	84.71			34.64	8.66	34.11	147	152	Average
5745	101.53	92.34			34.64	8.66	34.11	147	152	Peak
11490	48.27	33.15	54	-5.73	37.89	12.62	35.39	135	196	Average
11490	57.32	42.2	74	-16.68	37.89	12.62	35.39	135	196	Peak
Antenna Polarity & Test Distance: Vertical at 3 m										
Frequency (MHz)	Emission Level (dBuV/m)	Read Level (dBuV)	Limit (dBuV/m)	Margin (dB)	Antenna Factor (dB/m)	Cable Loss (dB)	Preamp Factor (dB)	Antenna Height (cm)	Table Angle (Degree)	Remark
5745	103.8	94.61			34.64	8.66	34.11	106	332	Average
5745	110.63	101.44			34.64	8.66	34.11	106	332	Peak
11490	47.38	32.26	54	-6.62	37.89	12.62	35.39	127	282	Average
11490	56.85	41.73	74	-17.15	37.89	12.62	35.39	127	282	Peak

<Out of Band Emission (OOBE)>

Antenna Polarity & Test Distance: Horizontal at 3 m										
Frequency (MHz)	Emission Level (dBuV/m)	Read Level (dBuV)	Limit (dBuV/m)	Margin (dB)	Antenna Factor (dB/m)	Cable Loss (dB)	Preamp Factor (dB)	Antenna Height (cm)	Table Angle (Degree)	Remark
*5618.125	43.22	34.17	54	-10.78	34.52	8.61	34.08	147	152	Average
*5618.125	53.94	44.89	74	-20.06	34.52	8.61	34.08	147	152	Peak
5653.825	53	43.91	76.39	-23.39	34.56	8.63	34.1	147	152	Peak
5919.475	52.55	43.17	77.45	-24.9	34.81	8.73	34.16	147	152	Peak
*5966.725	43.51	34.06	54	-10.49	34.87	8.75	34.17	147	152	Average
*5966.725	53.5	44.05	74	-20.5	34.87	8.75	34.17	147	152	Peak
Antenna Polarity & Test Distance: Vertical at 3 m										
Frequency (MHz)	Emission Level (dBuV/m)	Read Level (dBuV)	Limit (dBuV/m)	Margin (dB)	Antenna Factor (dB/m)	Cable Loss (dB)	Preamp Factor (dB)	Antenna Height (cm)	Table Angle (Degree)	Remark
*5645.425	43.55	34.48	54	-10.45	34.54	8.62	34.09	106	332	Average
*5645.425	55.25	46.18	74	-18.75	34.54	8.62	34.09	106	332	Peak
5653.825	53.93	44.84	76.39	-22.46	34.56	8.63	34.1	106	332	Peak
5922.625	53.42	44.02	75.48	-22.06	34.83	8.73	34.16	106	332	Peak
*6001.375	54.45	44.96	74	-19.55	34.9	8.76	34.17	106	332	Peak
*6004.525	43.64	34.15	54	-10.36	34.9	8.76	34.17	106	332	Average

Remarks:

- Emission Level = Read Level + Antenna Factor + Cable Loss - Preamp Factor
Margin value = Emission level – Limit value
- 5745 MHz: Fundamental Frequency
- *: Out of Restricted Band

EUT Test Condition		Measurement Detail	
Channel	Channel 157	Frequency Range	1 GHz ~ 40 GHz
Input Power	120 Vac, 60 Hz	Detector Function	Peak (PK) Average (AV)
Environmental Conditions	25 deg. C, 65 % RH	Tested By	Karl Lee

<Spurious Emission>

Antenna Polarity & Test Distance: Horizontal at 3 m										
Frequency (MHz)	Emission Level (dBuV/m)	Read Level (dBuV)	Limit (dBuV/m)	Margin (dB)	Antenna Factor (dB/m)	Cable Loss (dB)	Preamp Factor (dB)	Antenna Height (cm)	Table Angle (Degree)	Remark
5785	94.17	84.94			34.68	8.68	34.13	147	152	Average
5785	101.56	92.33			34.68	8.68	34.13	147	152	Peak
11570	46.82	31.51	54	-7.18	38	12.68	35.37	132	148	Average
11570	55.41	40.1	74	-18.59	38	12.68	35.37	132	148	Peak
Antenna Polarity & Test Distance: Vertical at 3 m										
Frequency (MHz)	Emission Level (dBuV/m)	Read Level (dBuV)	Limit (dBuV/m)	Margin (dB)	Antenna Factor (dB/m)	Cable Loss (dB)	Preamp Factor (dB)	Antenna Height (cm)	Table Angle (Degree)	Remark
5785	102.96	93.73			34.68	8.68	34.13	101	360	Average
5785	110.48	101.25			34.68	8.68	34.13	101	360	Peak
11570	46.73	31.42	54	-7.27	38	12.68	35.37	127	342	Average
11570	55.64	40.33	74	-18.36	38	12.68	35.37	127	342	Peak

<Out of Band Emission (OOBE)>

Antenna Polarity & Test Distance: Horizontal at 3 m										
Frequency (MHz)	Emission Level (dBuV/m)	Read Level (dBuV)	Limit (dBuV/m)	Margin (dB)	Antenna Factor (dB/m)	Cable Loss (dB)	Preamp Factor (dB)	Antenna Height (cm)	Table Angle (Degree)	Remark
*5612.35	43.19	34.16	54	-10.81	34.5	8.61	34.08	147	152	Average
*5612.35	54.17	45.14	74	-19.83	34.5	8.61	34.08	147	152	Peak
5652.25	52.64	43.55	75.4	-22.76	34.56	8.62	34.09	147	152	Peak
5921.575	51.74	42.34	76.14	-24.4	34.83	8.73	34.16	147	152	Peak
*5980.375	43.72	34.26	54	-10.28	34.88	8.75	34.17	147	152	Average
*5980.9	54.22	44.76	74	-19.78	34.88	8.75	34.17	147	152	Peak
Antenna Polarity & Test Distance: Vertical at 3 m										
Frequency (MHz)	Emission Level (dBuV/m)	Read Level (dBuV)	Limit (dBuV/m)	Margin (dB)	Antenna Factor (dB/m)	Cable Loss (dB)	Preamp Factor (dB)	Antenna Height (cm)	Table Angle (Degree)	Remark
*5606.05	43.51	34.48	54	-10.49	34.5	8.61	34.08	101	360	Average
*5606.05	54.56	45.53	74	-19.44	34.5	8.61	34.08	101	360	Peak
5653.825	53.73	44.64	76.39	-22.66	34.56	8.63	34.1	101	360	Peak
5918.95	53.15	43.77	77.78	-24.63	34.81	8.73	34.16	101	360	Peak
*5959.375	43.82	34.37	54	-10.18	34.87	8.74	34.16	101	360	Average
*5959.375	54.21	44.76	74	-19.79	34.87	8.74	34.16	101	360	Peak

Remarks:

- Emission Level = Read Level + Antenna Factor + Cable Loss - Preamp Factor
Margin value = Emission level – Limit value
- 5785 MHz: Fundamental Frequency
- *: Out of Restricted Band

EUT Test Condition		Measurement Detail	
Channel	Channel 161	Frequency Range	1 GHz ~ 40 GHz
Input Power	120 Vac, 60 Hz	Detector Function	Peak (PK) Average (AV)
Environmental Conditions	25 deg. C, 65 % RH	Tested By	Karl Lee

<Spurious Emission>

Antenna Polarity & Test Distance: Horizontal at 3 m										
Frequency (MHz)	Emission Level (dBuV/m)	Read Level (dBuV)	Limit (dBuV/m)	Margin (dB)	Antenna Factor (dB/m)	Cable Loss (dB)	Preamp Factor (dB)	Antenna Height (cm)	Table Angle (Degree)	Remark
5805	93.1	83.84			34.71	8.68	34.13	147	152	Average
5805	100.2	90.94			34.71	8.68	34.13	147	152	Peak
11610	47.24	31.81	54	-6.76	38.04	12.76	35.37	167	234	Average
11610	56.07	40.64	74	-17.93	38.04	12.76	35.37	167	234	Peak
Antenna Polarity & Test Distance: Vertical at 3 m										
Frequency (MHz)	Emission Level (dBuV/m)	Read Level (dBuV)	Limit (dBuV/m)	Margin (dB)	Antenna Factor (dB/m)	Cable Loss (dB)	Preamp Factor (dB)	Antenna Height (cm)	Table Angle (Degree)	Remark
5805	102.42	93.16			34.71	8.68	34.13	100	358	Average
5805	109.75	100.49			34.71	8.68	34.13	100	358	Peak
11610	46.58	31.15	54	-7.42	38.04	12.76	35.37	176	128	Average
11610	55.72	40.29	74	-18.28	38.04	12.76	35.37	176	128	Peak

<Out of Band Emission (OOBE)>

Antenna Polarity & Test Distance: Horizontal at 3 m										
Frequency (MHz)	Emission Level (dBuV/m)	Read Level (dBuV)	Limit (dBuV/m)	Margin (dB)	Antenna Factor (dB/m)	Cable Loss (dB)	Preamp Factor (dB)	Antenna Height (cm)	Table Angle (Degree)	Remark
*5631.775	43.16	34.11	54	-10.84	34.52	8.62	34.09	147	152	Average
*5631.775	53.87	44.82	74	-20.13	34.52	8.62	34.09	147	152	Peak
5652.775	52.56	43.46	75.73	-23.17	34.56	8.63	34.09	147	152	Peak
5922.1	52.79	43.39	75.81	-23.02	34.83	8.73	34.16	147	152	Peak
*5941	43.47	34.04	54	-10.53	34.85	8.74	34.16	147	152	Average
*5941	54.77	45.34	74	-19.23	34.85	8.74	34.16	147	152	Peak
Antenna Polarity & Test Distance: Vertical at 3 m										
Frequency (MHz)	Emission Level (dBuV/m)	Read Level (dBuV)	Limit (dBuV/m)	Margin (dB)	Antenna Factor (dB/m)	Cable Loss (dB)	Preamp Factor (dB)	Antenna Height (cm)	Table Angle (Degree)	Remark
*5595.55	43.58	34.57	54	-10.42	34.49	8.6	34.08	100	358	Average
*5595.55	54.44	45.43	74	-19.56	34.49	8.6	34.08	100	358	Peak
5651.725	52.96	43.87	75.08	-22.12	34.56	8.62	34.09	100	358	Peak
5922.625	53.07	43.67	75.48	-22.41	34.83	8.73	34.16	100	358	Peak
*5968.3	43.85	34.4	54	-10.15	34.87	8.75	34.17	100	358	Average
*5968.3	54.78	45.33	74	-19.22	34.87	8.75	34.17	100	358	Peak

Remarks:

- Emission Level = Read Level + Antenna Factor + Cable Loss - Preamp Factor
Margin value = Emission level – Limit value
- 5805 MHz: Fundamental Frequency
- *: Out of Restricted Band

802.11n (HT40)

EUT Test Condition		Measurement Detail	
Channel	Channel 38	Frequency Range	1 GHz ~ 40 GHz
Input Power	120 Vac, 60 Hz	Detector Function	Peak (PK) Average (AV)
Environmental Conditions	25 deg. C, 65 % RH	Tested By	Karl Lee

Antenna Polarity & Test Distance: Horizontal at 3 m

Frequency (MHz)	Emission Level (dBuV/m)	Read Level (dBuV)	Limit (dBuV/m)	Margin (dB)	Antenna Factor (dB/m)	Cable Loss (dB)	Preamp Factor (dB)	Antenna Height (cm)	Table Angle (Degree)	Remark
5120	42.15	33.95	54	-11.85	34.09	8.1	33.99	114	174	Average
5144	55.22	46.97	74	-18.78	34.12	8.13	34	114	174	Peak
5190	88.65	80.31			34.15	8.19	34	162	165	Average
5190	96.78	88.44			34.15	8.19	34	162	165	Peak
5400	52.15	43.43	74	-21.85	34.32	8.44	34.04	118	114	Peak
5410	41.51	32.79	54	-12.49	34.32	8.44	34.04	118	114	Average

Antenna Polarity & Test Distance: Vertical at 3 m

Frequency (MHz)	Emission Level (dBuV/m)	Read Level (dBuV)	Limit (dBuV/m)	Margin (dB)	Antenna Factor (dB/m)	Cable Loss (dB)	Preamp Factor (dB)	Antenna Height (cm)	Table Angle (Degree)	Remark
5039.9	52.51	44.44	54	-1.49	34.04	8	33.97	101	355	Average
5146.4	63.32	55.07	74	-10.68	34.12	8.13	34	101	355	Peak
5190	93.88	85.54			34.15	8.19	34	101	317	Average
5190	101.89	93.55			34.15	8.19	34	101	317	Peak
5399.94	43.8	35.08	54	-10.2	34.32	8.44	34.04	112	285	Average
5442.51	54.25	45.46	74	-19.75	34.35	8.48	34.04	112	285	Peak

Remarks:

- Emission Level = Read Level + Antenna Factor + Cable Loss - Preamp Factor
Margin value = Emission level – Limit value
- 5190 MHz: Fundamental Frequency
- *: Out of Restricted Band

EUT Test Condition		Measurement Detail	
Channel	Channel 46	Frequency Range	1 GHz ~ 40 GHz
Input Power	120 Vac, 60 Hz	Detector Function	Peak (PK) Average (AV)
Environmental Conditions	25 deg. C, 65 % RH	Tested By	Karl Lee

Antenna Polarity & Test Distance: Horizontal at 3 m										
Frequency (MHz)	Emission Level (dBuV/m)	Read Level (dBuV)	Limit (dBuV/m)	Margin (dB)	Antenna Factor (dB/m)	Cable Loss (dB)	Preamp Factor (dB)	Antenna Height (cm)	Table Angle (Degree)	Remark
5098	43.69	35.53	54	-10.31	34.08	8.07	33.99	162	288	Average
5098	63.2	55.04	74	-10.8	34.08	8.07	33.99	162	288	Peak
5230	90.44	82.04			34.19	8.22	34.01	162	288	Average
5230	97.27	88.87			34.19	8.22	34.01	162	288	Peak
5448	44.21	35.38	54	-9.79	34.36	8.51	34.04	162	288	Average
5448	64.17	55.34	74	-9.83	34.36	8.51	34.04	162	288	Peak

Antenna Polarity & Test Distance: Vertical at 3 m										
Frequency (MHz)	Emission Level (dBuV/m)	Read Level (dBuV)	Limit (dBuV/m)	Margin (dB)	Antenna Factor (dB/m)	Cable Loss (dB)	Preamp Factor (dB)	Antenna Height (cm)	Table Angle (Degree)	Remark
5116	47.75	39.55	54	-6.25	34.09	8.1	33.99	126	100	Average
5116	64.11	55.91	74	-9.89	34.09	8.1	33.99	126	100	Peak
5230	100.89	92.49			34.19	8.22	34.01	126	100	Average
5230	108.14	99.74			34.19	8.22	34.01	126	100	Peak
5460	47.26	38.44	54	-6.74	34.36	8.51	34.05	126	100	Average
5460	64.97	56.15	74	-9.03	34.36	8.51	34.05	126	100	Peak

Remarks:

- Emission Level = Read Level + Antenna Factor + Cable Loss - Preamp Factor
Margin value = Emission level – Limit value
- 5230 MHz: Fundamental Frequency
- *: Out of Restricted Band

EUT Test Condition		Measurement Detail	
Channel	Channel 151	Frequency Range	1 GHz ~ 40 GHz
Input Power	120 Vac, 60 Hz	Detector Function	Peak (PK) Average (AV)
Environmental Conditions	25 deg. C, 65 % RH	Tested By	Karl Lee

<Spurious Emission>

Antenna Polarity & Test Distance: Horizontal at 3 m										
Frequency (MHz)	Emission Level (dBuV/m)	Read Level (dBuV)	Limit (dBuV/m)	Margin (dB)	Antenna Factor (dB/m)	Cable Loss (dB)	Preamp Factor (dB)	Antenna Height (cm)	Table Angle (Degree)	Remark
5755	89.96	80.75			34.66	8.66	34.11	246	152	Average
5755	97.53	88.32			34.66	8.66	34.11	246	152	Peak
11510	47.25	32.14	54	-6.75	37.9	12.6	35.39	174	309	Average
11510	56.02	40.91	74	-17.98	37.9	12.6	35.39	174	309	Peak
Antenna Polarity & Test Distance: Vertical at 3 m										
Frequency (MHz)	Emission Level (dBuV/m)	Read Level (dBuV)	Limit (dBuV/m)	Margin (dB)	Antenna Factor (dB/m)	Cable Loss (dB)	Preamp Factor (dB)	Antenna Height (cm)	Table Angle (Degree)	Remark
5755	99.35	90.14			34.66	8.66	34.11	106	332	Average
5755	106.93	97.72			34.66	8.66	34.11	106	332	Peak
11510	46.82	31.71	54	-7.18	37.9	12.6	35.39	174	165	Average
11510	55.35	40.24	74	-18.65	37.9	12.6	35.39	174	165	Peak

<Out of Band Emission (OOBE)>

Antenna Polarity & Test Distance: Horizontal at 3 m										
Frequency (MHz)	Emission Level (dBuV/m)	Read Level (dBuV)	Limit (dBuV/m)	Margin (dB)	Antenna Factor (dB/m)	Cable Loss (dB)	Preamp Factor (dB)	Antenna Height (cm)	Table Angle (Degree)	Remark
*5582.425	43.02	34.01	54	-10.98	34.49	8.6	34.08	246	152	Average
*5582.425	54.73	45.72	74	-19.27	34.49	8.6	34.08	246	152	Peak
5656.45	53.99	44.9	78.02	-24.03	34.56	8.63	34.1	246	152	Peak
5920	54.26	44.88	77.12	-22.86	34.81	8.73	34.16	246	152	Peak
*5983	43.8	34.34	54	-10.2	34.88	8.75	34.17	246	152	Average
*5983	54.63	45.17	74	-19.37	34.88	8.75	34.17	246	152	Peak
Antenna Polarity & Test Distance: Vertical at 3 m										
Frequency (MHz)	Emission Level (dBuV/m)	Read Level (dBuV)	Limit (dBuV/m)	Margin (dB)	Antenna Factor (dB/m)	Cable Loss (dB)	Preamp Factor (dB)	Antenna Height (cm)	Table Angle (Degree)	Remark
*5542.525	43.23	34.29	54	-10.77	34.43	8.58	34.07	106	332	Average
*5542.525	54.35	45.41	74	-19.65	34.43	8.58	34.07	106	332	Peak
5654.35	54.01	44.92	76.71	-22.7	34.56	8.63	34.1	106	332	Peak
5920	52.79	43.41	77.12	-24.33	34.81	8.73	34.16	106	332	Peak
*5941	43.64	34.21	54	-10.36	34.85	8.74	34.16	106	332	Average
*5941	54.39	44.96	74	-19.61	34.85	8.74	34.16	106	332	Peak

Remarks:

- Emission Level = Read Level + Antenna Factor + Cable Loss - Preamp Factor
Margin value = Emission level – Limit value
- 5755 MHz: Fundamental Frequency
- *: Out of Restricted Band

EUT Test Condition		Measurement Detail	
Channel	Channel 159	Frequency Range	1 GHz ~ 40 GHz
Input Power	120 Vac, 60 Hz	Detector Function	Peak (PK) Average (AV)
Environmental Conditions	25 deg. C, 65 % RH	Tested By	Karl Lee

<Spurious Emission>

Antenna Polarity & Test Distance: Horizontal at 3 m										
Frequency (MHz)	Emission Level (dBuV/m)	Read Level (dBuV)	Limit (dBuV/m)	Margin (dB)	Antenna Factor (dB/m)	Cable Loss (dB)	Preamp Factor (dB)	Antenna Height (cm)	Table Angle (Degree)	Remark
5795	89.5	80.26			34.69	8.68	34.13	147	152	Average
5795	97.41	88.17			34.69	8.68	34.13	147	152	Peak
11590	47.13	31.76	54	-6.87	38.02	12.72	35.37	163	184	Average
11590	56.63	41.26	74	-17.37	38.02	12.72	35.37	163	184	Peak
Antenna Polarity & Test Distance: Vertical at 3 m										
Frequency (MHz)	Emission Level (dBuV/m)	Read Level (dBuV)	Limit (dBuV/m)	Margin (dB)	Antenna Factor (dB/m)	Cable Loss (dB)	Preamp Factor (dB)	Antenna Height (cm)	Table Angle (Degree)	Remark
5795	99.33	90.09			34.69	8.68	34.13	108	358	Average
5795	106.37	97.13			34.69	8.68	34.13	108	358	Peak
11590	46.39	31.02	54	-7.61	38.02	12.72	35.37	128	243	Average
11590	55.65	40.28	74	-18.35	38.02	12.72	35.37	128	243	Peak

<Out of Band Emission (OOBE)>

Antenna Polarity & Test Distance: Horizontal at 3 m										
Frequency (MHz)	Emission Level (dBuV/m)	Read Level (dBuV)	Limit (dBuV/m)	Margin (dB)	Antenna Factor (dB/m)	Cable Loss (dB)	Preamp Factor (dB)	Antenna Height (cm)	Table Angle (Degree)	Remark
*5590.3	43.24	34.23	54	-10.76	34.49	8.6	34.08	147	152	Average
*5590.3	53.93	44.92	74	-20.07	34.49	8.6	34.08	147	152	Peak
5651.725	52.89	43.8	75.08	-22.19	34.56	8.62	34.09	147	152	Peak
5922.1	52.55	43.15	75.81	-23.26	34.83	8.73	34.16	147	152	Peak
*6019.225	43.65	34.14	54	-10.35	34.92	8.77	34.18	147	152	Average
*6019.225	53.72	44.21	74	-20.28	34.92	8.77	34.18	147	152	Peak
Antenna Polarity & Test Distance: Vertical at 3 m										
Frequency (MHz)	Emission Level (dBuV/m)	Read Level (dBuV)	Limit (dBuV/m)	Margin (dB)	Antenna Factor (dB/m)	Cable Loss (dB)	Preamp Factor (dB)	Antenna Height (cm)	Table Angle (Degree)	Remark
*5589.25	43.69	34.68	54	-10.31	34.49	8.6	34.08	108	358	Average
*5589.25	54.89	45.88	74	-19.11	34.49	8.6	34.08	108	358	Peak
5656.45	53.92	44.83	78.02	-24.1	34.56	8.63	34.1	108	358	Peak
5923.675	52.49	43.09	74.83	-22.34	34.83	8.73	34.16	108	358	Peak
*6020.275	43.73	34.22	54	-10.27	34.92	8.77	34.18	108	358	Average
*6020.275	54.46	44.95	74	-19.54	34.92	8.77	34.18	108	358	Peak

Remarks:

- Emission Level = Read Level + Antenna Factor + Cable Loss - Preamp Factor
Margin value = Emission level – Limit value
- 5795 MHz: Fundamental Frequency
- *: Out of Restricted Band

9 kHz ~ 30 MHz DATA:

The amplitude of spurious emissions attenuated more than 20 dB below the permissible value is not required to be report.

30 MHz ~ 1 GHz WORST-CASE DATA:

802.11a

EUT Test Condition		Measurement Detail	
Channel	Channel 36	Frequency Range	30 MHz ~ 1 GHz
Input Power	120 Vac, 60 Hz	Detector Function	Peak (PK) Quasi-peak (QP)
Environmental Conditions	25 deg. C, 65 % RH	Tested By	Karl Lee

Antenna Polarity & Test Distance: Horizontal at 3 m										
Frequency (MHz)	Emission Level (dBuV/m)	Read Level (dBuV)	Limit (dBuV/m)	Margin (dB)	Antenna Factor (dB/m)	Cable Loss (dB)	Preamp Factor (dB)	Antenna Height (cm)	Table Angle (Degree)	Remark
99.66	23.21	44.53	43.5	-20.29	9.66	1.28	32.26	155	124	Peak
166.62	25.36	45.8	43.5	-18.14	10.29	1.52	32.25	165	216	Peak
220.89	38.87	57.71	46	-7.13	11.72	1.65	32.21	158	215	Peak
311.2	38.01	53.51	46	-7.99	14.51	2.11	32.12	135	221	Peak
498.1	33.62	44.09	46	-12.38	19	2.63	32.1	165	124	Peak
697.6	29.41	35.29	46	-16.59	23.1	3.11	32.09	102	115	Peak

Antenna Polarity & Test Distance: Vertical at 3 m										
Frequency (MHz)	Emission Level (dBuV/m)	Read Level (dBuV)	Limit (dBuV/m)	Margin (dB)	Antenna Factor (dB/m)	Cable Loss (dB)	Preamp Factor (dB)	Antenna Height (cm)	Table Angle (Degree)	Remark
30	32.42	46.15	40	-7.58	17.8	0.74	32.27	165	216	Peak
99.66	22.4	43.72	43.5	-21.1	9.66	1.28	32.26	135	216	Peak
166.62	28.08	48.52	43.5	-15.42	10.29	1.52	32.25	158	20	Peak
365.1	26.22	39.74	46	-19.78	16.33	2.26	32.11	157	158	Peak
499.5	30.84	41.31	46	-15.16	19	2.63	32.1	166	215	Peak
869.8	31.58	35.21	46	-14.42	24.6	3.44	31.67	102	55	Peak

Remarks:

1. Emission Level = Read Level + Antenna Factor + Cable Loss - Preamp Factor

Margin value = Emission level – Limit value

802.11a

EUT Test Condition		Measurement Detail	
Channel	Channel 165	Frequency Range	30 MHz ~ 1 GHz
Input Power	120 Vac, 60 Hz	Detector Function	Peak (PK) Quasi-peak (QP)
Environmental Conditions	25 deg. C, 65 % RH	Tested By	Karl Lee

Antenna Polarity & Test Distance: Horizontal at 3 m

Frequency (MHz)	Emission Level (dBuV/m)	Read Level (dBuV)	Limit (dBuV/m)	Margin (dB)	Antenna Factor (dB/m)	Cable Loss (dB)	Preamp Factor (dB)	Antenna Height (cm)	Table Angle (Degree)	Remark
99.93	23.62	44.94	43.5	-19.88	9.66	1.28	32.26	165	215	Peak
166.62	24.02	44.46	43.5	-19.48	10.29	1.52	32.25	155	145	Peak
200.1	37.61	57.36	43.5	-5.89	10.9	1.65	32.3	102	135	Peak
318.2	38.54	53.69	46	-7.46	14.85	2.11	32.11	105	165	Peak
499.5	34.03	44.5	46	-11.97	19	2.63	32.1	157	114	Peak
700.4	30.38	36.26	46	-15.62	23.1	3.11	32.09	158	51	Peak

Antenna Polarity & Test Distance: Vertical at 3 m

Frequency (MHz)	Emission Level (dBuV/m)	Read Level (dBuV)	Limit (dBuV/m)	Margin (dB)	Antenna Factor (dB/m)	Cable Loss (dB)	Preamp Factor (dB)	Antenna Height (cm)	Table Angle (Degree)	Remark
30.27	31.96	45.94	40	-8.04	17.55	0.74	32.27	161	201	Peak
99.66	23.4	44.72	43.5	-20.1	9.66	1.28	32.26	155	124	Peak
300	36.84	53.05	46	-9.16	13.9	2.03	32.14	100	360	Peak
497.4	31.35	41.83	46	-14.65	18.99	2.63	32.1	157	154	Peak
664	28.03	34.42	46	-17.97	22.75	2.99	32.13	158	102	Peak
700.4	27.59	33.47	46	-18.41	23.1	3.11	32.09	155	220	Peak

Remarks:

- Emission Level = Read Level + Antenna Factor + Cable Loss - Preamp Factor
Margin value = Emission level – Limit value

4.2 Transmit Power Measurement

4.2.1 Limits of Transmit Power Measurement

Operation Band	EUT Category		Limit
U-NII-1		Outdoor Access Point	1 Watt (30 dBm) (Max. e.i.r.p \leq 125 mW (21 dBm) at any elevation angle above 30 degrees as measured from the horizon)
		Fixed point-to-point Access Point	1 Watt (30 dBm)
		Indoor Access Point	1 Watt (30 dBm)
	√	Mobile and Portable client device	250 mW (24 dBm)
U-NII-2A		-	250 mW (24 dBm) or 11 dBm+10 log B*
U-NII-2C		-	250 mW (24 dBm) or 11 dBm+10 log B*
U-NII-3		√	1 Watt (30 dBm)

*B is the 26 dB emission bandwidth in megahertz

Per KDB 662911 Method of conducted output power measurement on IEEE 802.11 devices,

Array Gain = 0 dB (i.e., no array gain) for $N_{ANT} \leq 4$;

Array Gain = 0 dB (i.e., no array gain) for channel widths ≥ 40 MHz for any N_{ANT} ;

Array Gain = $5 \log(N_{ANT}/N_{SS})$ dB or 3 dB, whichever is less for 20 MHz channel widths with $N_{ANT} \geq 5$.

For power measurements on all other devices: Array Gain = $10 \log(N_{ANT}/N_{SS})$ dB.

4.2.2 Test Setup

<Power Output Measurement>

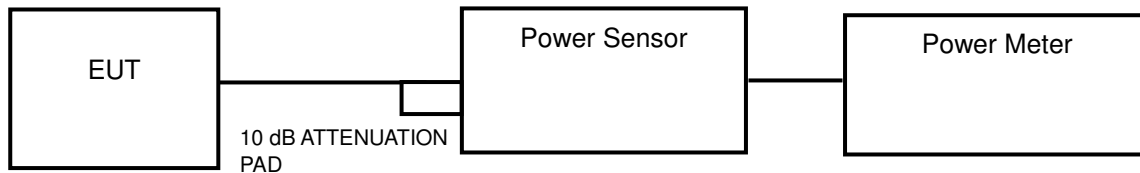

<26 dB Bandwidth / Occupied Bandwidth>

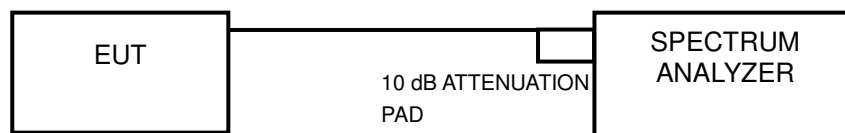

4.2.3 Test Instruments

Refer to section 4.1.2 to get information of above instrument.

4.2.4 Test Procedure

Average Power Measurement

Method PM is used to perform output power measurement, trigger and gating function of wide band power meter is enabled to measure max output power of TX on burst. Duty factor is not added to measured value.

26 dB Bandwidth

- 1) Set RBW = approximately 1 % of the emission bandwidth.
- 2) Set the VBW > RBW.
- 3) Detector = Peak.
- 4) Trace mode = max hold.
- 5) Measure the maximum width of the emission that is 26 dB down from the peak of the emission. Compare this with the RBW setting of the analyzer. Readjust RBW and repeat measurement as needed until the RBW/EBW ratio is approximately 1 %.

Occupied Bandwidth

The transmitter output was connected to the spectrum analyzer through an attenuator. The bandwidth of the fundamental frequency was measured by spectrum analyzer with resolution bandwidth in the range of 1 % to 5 % of the anticipated emission bandwidth, and a video bandwidth at least 3x the resolution bandwidth and set the detector to Sampling. The width of a frequency band such that, below the lower and above the upper frequency limits, the mean powers emitted are each equal to a specified percentage 0.5 % of the total mean power of a given emission.

4.2.5 Deviation from Test Standard

No deviation.

4.2.6 EUT Operating Conditions

The software provided by client to enable the EUT under transmission condition continuously at lowest, middle and highest channel frequencies individually.

4.2.7 Test Result

Power Output:
Mode A
802.11a

Channel	Frequency (MHz)	Maximum Conducted Power (mW)	Maximum Conducted Power (dBm)	Power Limit (dBm)	Pass / Fail
36	5180	26.303	14.20	24	Pass
44	5220	26.853	14.29	24	Pass
48	5240	25.235	14.02	24	Pass
149	5745	18.578	12.69	30	Pass
157	5785	20.324	13.08	30	Pass
161	5805	19.724	12.95	30	Pass

802.11n (HT20)

Channel	Frequency (MHz)	Maximum Conducted Power (mW)	Maximum Conducted Power (dBm)	Power Limit (dBm)	Pass / Fail
36	5180	33.037	15.19	24	Pass
44	5220	32.434	15.11	24	Pass
48	5240	28.054	14.48	24	Pass
149	5745	18.239	12.61	30	Pass
157	5785	21.627	13.35	30	Pass
161	5805	21.677	13.36	30	Pass

802.11n (HT40)

Channel	Frequency (MHz)	Maximum Conducted Power (mW)	Maximum Conducted Power (dBm)	Power Limit (dBm)	Pass / Fail
38	5190	16.069	12.06	24	Pass
46	5230	15.631	11.94	24	Pass
151	5755	27.99	14.47	30	Pass
159	5795	29.854	14.75	30	Pass

Mode B
802.11n (HT20)

Channel	Frequency (MHz)	Maximum Cunducted Power (dBm)			Total Power (mW)	Total Power (dBm)	Power Limit (dBm)	Pass / Fail
		Chain 0	Chain 1	Chain 2				
36	5180	10.75	10.67	10.18	33.976	15.31	24	Pass
44	5220	10.89	10.46	10.18	33.814	15.29	24	Pass
48	5240	10.62	10.22	10.11	32.312	15.09	24	Pass
149	5745	12.96	12.43	13.36	58.945	17.70	30	Pass
157	5785	13.11	12.84	13.82	63.794	18.05	30	Pass
161	5805	13.21	12.76	12.86	59.141	17.72	30	Pass

802.11n (HT40)

Channel	Frequency (MHz)	Maximum Cunducted Power (dBm)			Total Power (mW)	Total Power (dBm)	Power Limit (dBm)	Pass / Fail
		Chain 0	Chain 1	Chain 2				
38	5190	10.21	10.87	10.29	33.404	15.24	24	Pass
46	5230	8.53	8.43	9.23	22.47	13.52	24	Pass
151	5755	14.32	14.16	14.23	79.587	19.01	30	Pass
159	5795	14.44	14.29	14.33	81.752	19.12	30	Pass

26 dB Bandwidth:
Mode A
802.11a

Channel	Frequency (MHz)	26 dBc Bandwidth (MHz)
36	5180	24.81
44	5220	27.75
48	5240	24.90

802.11n (HT20)

Channel	Frequency (MHz)	26 dBc Bandwidth (MHz)
36	5180	23.94
44	5220	23.20
48	5240	22.50

802.11n (HT40)

Channel	Frequency (MHz)	26 dBc Bandwidth (MHz)
38	5190	43.57
46	5230	43.14

Mode B
802.11n (HT20)

Channel	Frequency (MHz)	26 dBc Bandwidth (MHz)		
		Chain 0	Chain 1	Chain 2
36	5180	21.26	21.43	21.56
44	5220	21.37	21.51	21.19
48	5240	20.98	21.28	21.23

802.11n (HT40)

Channel	Frequency (MHz)	26 dBc Bandwidth (MHz)		
		Chain 0	Chain 1	Chain 2
38	5190	41.75	43.46	42.06
46	5230	42.70	43.45	42.07

Spectrum Plot of Worst Value

802.11a

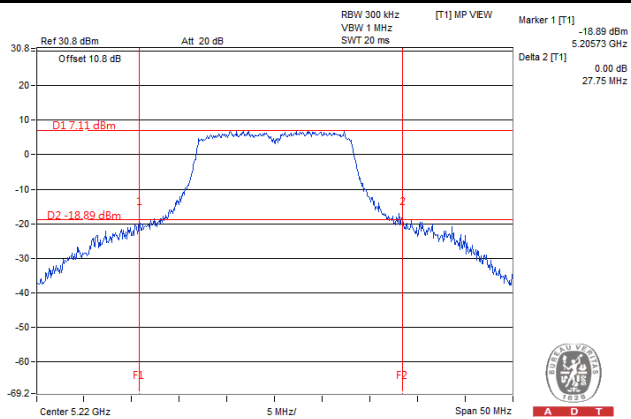

802.11n (HT20)

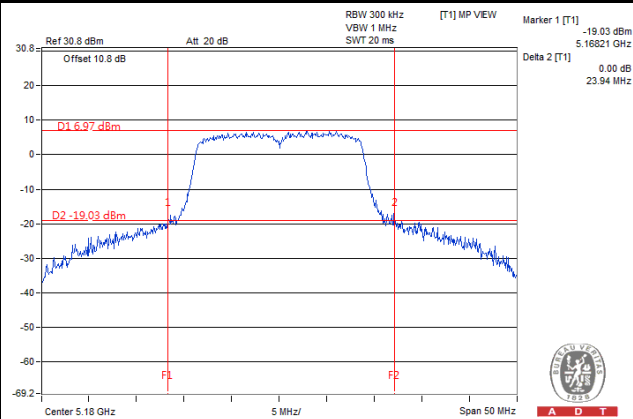

802.11n (HT40)

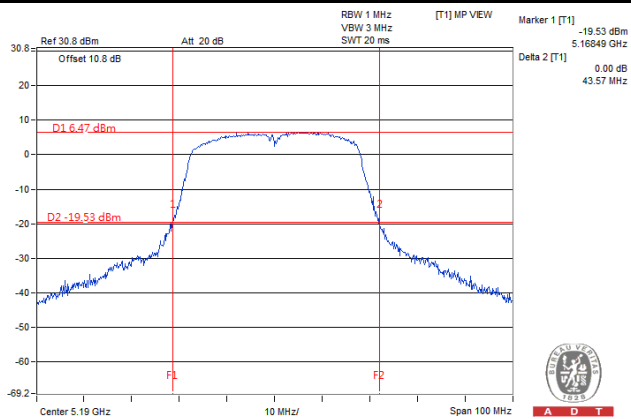

Occupied Bandwidth:
Mode A
802.11a

Channel	Frequency (MHz)	Occupied Bandwidth (MHz)
36	5180	17.12
44	5220	17.12
48	5240	17.07

802.11n (HT20)

Channel	Frequency (MHz)	Occupied Bandwidth (MHz)
36	5180	17.74
44	5220	17.74
48	5240	17.74

802.11n (HT40)

Channel	Frequency (MHz)	Occupied Bandwidth (MHz)
38	5190	36.15
46	5230	36.15

Mode B
802.11n (HT20)

Channel	Frequency (MHz)	Occupied Bandwidth (MHz)		
		Chain 0	Chain 1	Chain 2
36	5180	17.69	17.69	17.69
44	5220	17.84	17.74	17.64
48	5240	17.64	17.79	17.69

802.11n (HT40)

Channel	Frequency (MHz)	Occupied Bandwidth (MHz)		
		Chain 0	Chain 1	Chain 2
38	5190	36.03	36.28	36.03
46	5230	36.28	36.15	36.28

Spectrum Plot of Worst Value

802.11a

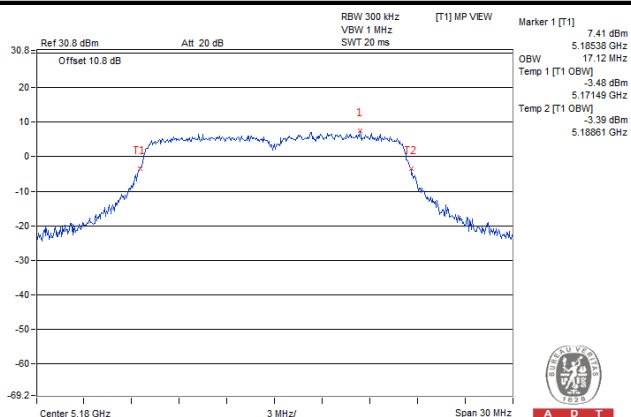

802.11n (HT20)

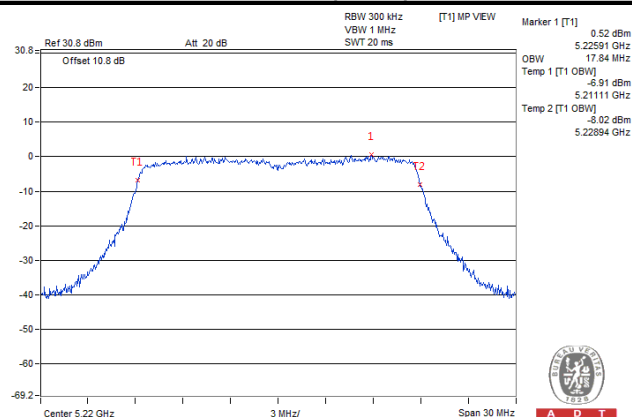

802.11n (HT40)

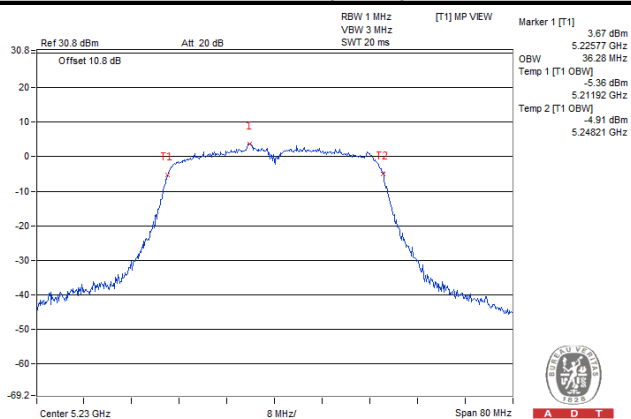

4.3 Peak Power Spectral Density Measurement

4.3.1 Limits of Peak Power Spectral Density Measurement

Operation Band	EUT Category		Limit
U-NII-1		Outdoor Access Point	17 dBm/MHz
		Fixed point-to-point Access Point	
		Indoor Access Point	
	√	Mobile and Portable client device	11 dBm/MHz
U-NII-2A	-		11 dBm/MHz
U-NII-2C	-		11 dBm/MHz
U-NII-3	√		30 dBm/500 kHz

4.3.2 Test Setup

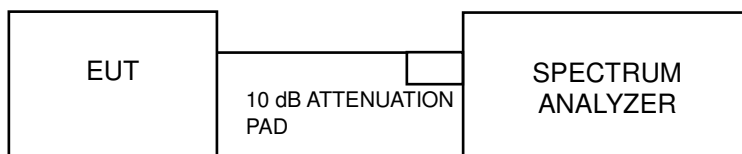

4.3.3 Test Instruments

Refer to section 4.1.3 to get information of above instrument.

4.3.4 Test Procedures

For U-NII-1 band:

Using method SA-2

1. Set span to encompass the entire emission bandwidth (EBW) of the signal.
2. Set RBW = 1 MHz, Set VBW ≥ 3 RBW, Detector = RMS
3. Sweep time = auto, trigger set to “free run”.
4. Trace average at least 100 traces in power averaging mode.
5. Record the max value and add 10 log (1/duty cycle)

For U-NII-3:

1. Set span to encompass the entire emission bandwidth (EBW) of the signal.
2. Set RBW = 500 kHz, Set VBW ≥ 3 RBW, Detector = RMS
3. Use the peak marker function to determine the maximum power level in any 500 kHz band segment within the fundamental EBW.
4. Sweep time = auto, trigger set to “free run”.
5. Trace average at least 100 traces in power averaging mode.
6. Record the max value and add 10 log (1/duty cycle)

4.3.5 Deviation from Test Standard

No deviation.

4.3.6 EUT Operating Conditions

The software provided by client to enable the EUT under transmission condition continuously at lowest, middle and highest channel frequencies individually.

4.3.7 Test Results

For U-NII-1 Band

Mode A

802.11a

Channel	Frequency (MHz)	PSD w/o Duty Factor (dBm/MHz)	Duty Factor (dB)	PSD with Duty Factor (dBm/MHz)	Maximum Limit (dBm/MHz)	Pass / Fail
36	5180	3.54	0.14	3.68	11	Pass
44	5220	3.64	0.14	3.78	11	Pass
48	5240	3.37	0.14	3.51	11	Pass

Note: Refer to section 3.3 for duty cycle spectrum plot.

802.11n (HT20)

Channel	Frequency (MHz)	PSD w/o Duty Factor (dBm/MHz)	Duty Factor (dB)	PSD with Duty Factor (dBm/MHz)	Maximum Limit (dBm/MHz)	Pass / Fail
36	5180	3.29	0.16	3.45	11	Pass
44	5220	3.13	0.16	3.29	11	Pass
48	5240	2.93	0.16	3.09	11	Pass

Note: Refer to section 3.3 for duty cycle spectrum plot.

802.11n (HT40)

Channel	Frequency (MHz)	PSD w/o Duty Factor (dBm/MHz)	Duty Factor (dB)	PSD with Duty Factor (dBm/MHz)	Maximum Limit (dBm/MHz)	Pass / Fail
38	5190	-2.38	0.25	-2.13	11	Pass
46	5230	-2.47	0.25	-2.22	11	Pass

Note: Refer to section 3.3 for duty cycle spectrum plot.

Mode B

802.11n (HT20)

Channel	Frequency (MHz)	PSD (dBm/MHz)			Duty Factor (dB)	Total PSD with Duty Factor (dBm/MHz)	Max. Limit (dBm/MHz)	Pass / Fail
		Chain 0	Chain 1	Chain 2				
36	5180	-2.13	-3.47	-2.15	0.42	2.65	10.23	Pass
44	5220	-2.79	-4.84	-2.23	0.42	2.04	10.23	Pass
48	5240	-3.17	-5.20	-2.18	0.42	1.84	10.23	Pass

Note:

1. Method 1 of power density measurement of KDB 662911 is using for calculating total power density. Total power density is summing entire spectra across corresponding frequency bins on the various outputs by computer.
2. Directional gain = 2 dBi + 10log(3) = 6.77 dBi > 6 dBi , so the power density limit shall be reduced to 11-(6.77-6) = 10.23 dBm.
3. Refer to section 3.3 for duty cycle spectrum plot.

802.11n (HT40)

Channel	Frequency (MHz)	PSD (dBm/MHz)			Duty Factor (dB)	Total PSD with Duty Factor (dBm/MHz)	Max. Limit (dBm/MHz)	Pass / Fail
		Chain 0	Chain 1	Chain 2				
38	5190	-5.99	-6.59	-7.40	0.54	-1.30	10.23	Pass
46	5230	-6.85	-6.34	-7.22	0.54	-1.47	10.23	Pass

Note:

1. Method 1 of power density measurement of KDB 662911 is using for calculating total power density. Total power density is summing entire spectra across corresponding frequency bins on the various outputs by computer.
2. Directional gain = 2 dBi + 10log(3) = 6.77 dBi > 6 dBi , so the power density limit shall be reduced to 11-(6.77-6) = 10.23 dBm.
3. Refer to section 3.3 for duty cycle spectrum plot.

Spectrum Plot of Worst Value

802.11a

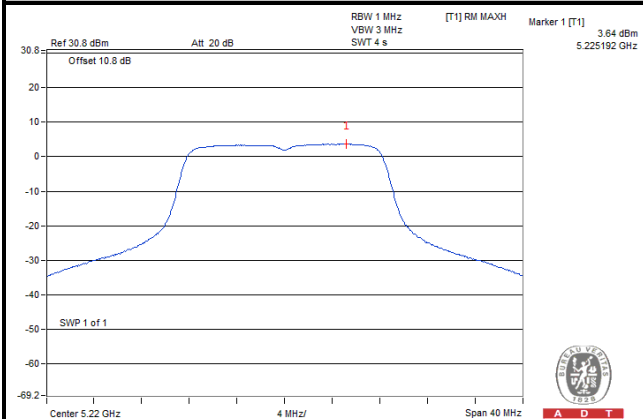

802.11n (HT20)

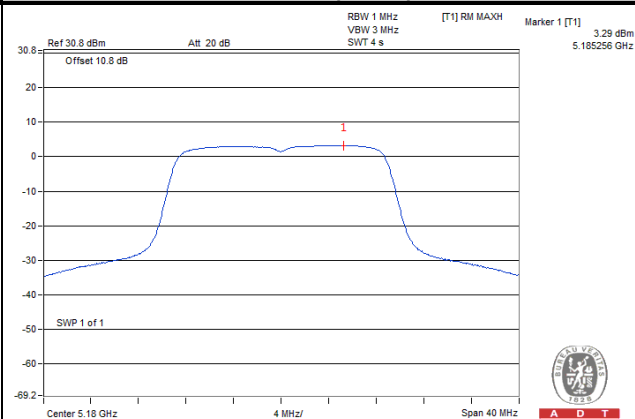

802.11n (HT40)

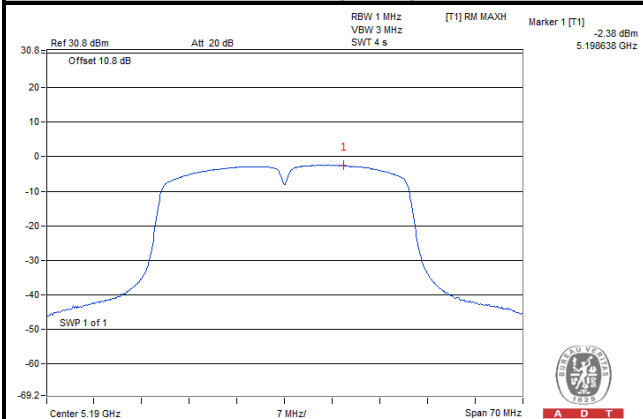

For U-NII-3 Band

Mode A

802.11a

Channel	Frequency (MHz)	PSD w/o Duty Factor (dBm/500 kHz)	Duty Factor (dB)	PSD with Duty Factor (dBm/500 kHz)	Limit (dBm/500 kHz)	Pass / Fail
149	5745	-2.49	0.14	-2.35	30	Pass
157	5785	-2.07	0.14	-1.93	30	Pass
161	5805	-2.30	0.14	-2.16	30	Pass

Note: Refer to section 3.3 for duty cycle spectrum plot.

802.11n (HT20)

Channel	Frequency (MHz)	PSD w/o Duty Factor (dBm/500 kHz)	Duty Factor (dB)	PSD with Duty Factor (dBm/500 kHz)	Limit (dBm/500 kHz)	Pass / Fail
149	5745	-2.61	0.16	-2.45	30	Pass
157	5785	-1.63	0.16	-1.47	30	Pass
161	5805	-1.88	0.16	-1.72	30	Pass

Note: Refer to section 3.3 for duty cycle spectrum plot.

802.11n (HT40)

Channel	Frequency (MHz)	PSD w/o Duty Factor (dBm/500 kHz)	Duty Factor (dB)	PSD with Duty Factor (dBm/500 kHz)	Limit (dBm/500 kHz)	Pass / Fail
151	5755	-3.80	0.25	-3.55	30	Pass
159	5795	-3.68	0.25	-3.43	30	Pass

Note: Refer to section 3.3 for duty cycle spectrum plot.

Mode B

802.11n (HT20)

TX Chain	Channel	Frequency (MHz)	PSD (dBm/500 kHz)	10 log (N=3) dB	Duty Factor (dB)	Total PSD with Duty Factor (dBm/500 kHz)	Limit (dBm/500 kHz)	Pass / Fail
0	149	5745	-2.69	4.77	0.42	2.50	29.23	Pass
	157	5785	-2.00	4.77	0.42	3.19	29.23	Pass
	161	5805	-1.71	4.77	0.42	3.48	29.23	Pass
1	149	5745	-2.68	4.77	0.42	2.51	29.23	Pass
	157	5785	-1.85	4.77	0.42	3.34	29.23	Pass
	161	5805	-1.88	4.77	0.42	3.31	29.23	Pass
2	149	5745	-2.51	4.77	0.42	2.68	29.23	Pass
	157	5785	-1.73	4.77	0.42	3.46	29.23	Pass
	161	5805	-2.27	4.77	0.42	2.92	29.23	Pass

Note:

- Method 1 of power density measurement of KDB 662911 is using for calculating total power density. Total power density is summing entire spectra across corresponding frequency bins on the various outputs by computer.
- Directional gain = 2 dBi + 10log(3) = 6.77 dBi > 6 dBi , so the power density limit shall be reduced to 30-(6.77-6) = 29.23 dBm.
- Refer to section 3.3 for duty cycle spectrum plot.

802.11n (HT40)

TX Chain	Channel	Frequency (MHz)	PSD (dBm/500 kHz)	10 log (N=3) dB	Duty Factor (dB)	Total PSD with Duty Factor (dBm/500 kHz)	Limit (dBm/500 kHz)	Pass / Fail
0	151	5755	-3.13	4.77	0.54	2.18	29.23	Pass
	159	5795	-2.82	4.77	0.54	2.49	29.23	Pass
1	151	5755	-3.51	4.77	0.54	1.80	29.23	Pass
	159	5795	-2.71	4.77	0.54	2.60	29.23	Pass
2	151	5755	-3.66	4.77	0.54	1.65	29.23	Pass
	159	5795	-3.22	4.77	0.54	2.09	29.23	Pass

Note:

- Method 1 of power density measurement of KDB 662911 is using for calculating total power density. Total power density is summing entire spectra across corresponding frequency bins on the various outputs by computer.
- Directional gain = 2 dBi + 10log(3) = 6.77 dBi > 6 dBi , so the power density limit shall be reduced to 30-(6.77-6) = 29.23 dBm.
- Refer to section 3.3 for duty cycle spectrum plot.

Spectrum Plot of Worst Value

802.11a

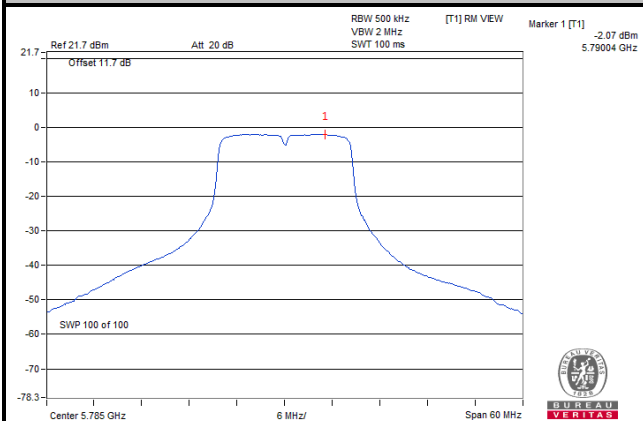

802.11n (HT20)

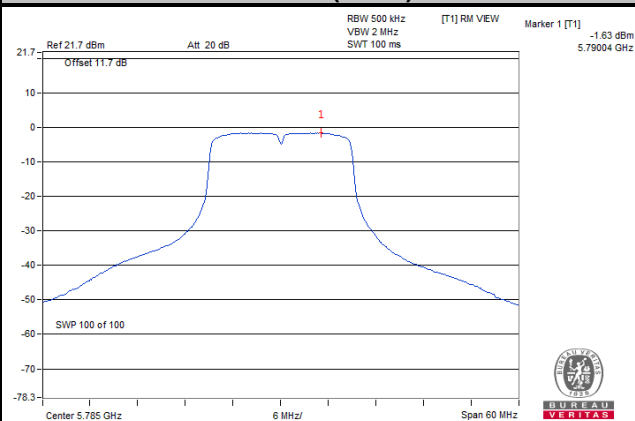

802.11n (HT40)

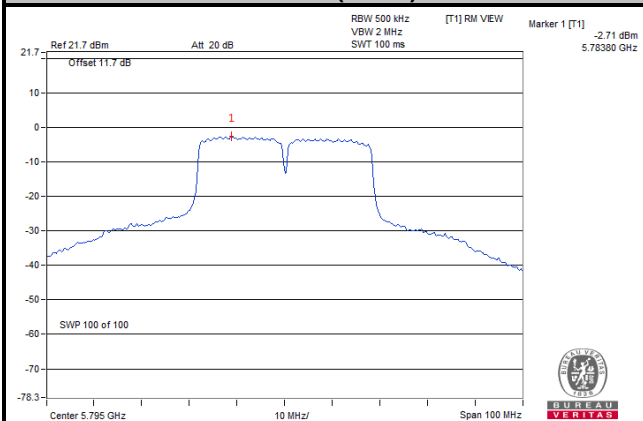

4.4 Frequency Stability

4.4.1 Limit of Frequency Stability Measurement

The frequency of the carrier signal shall be maintained within band of operation.

4.4.2 Test Setup

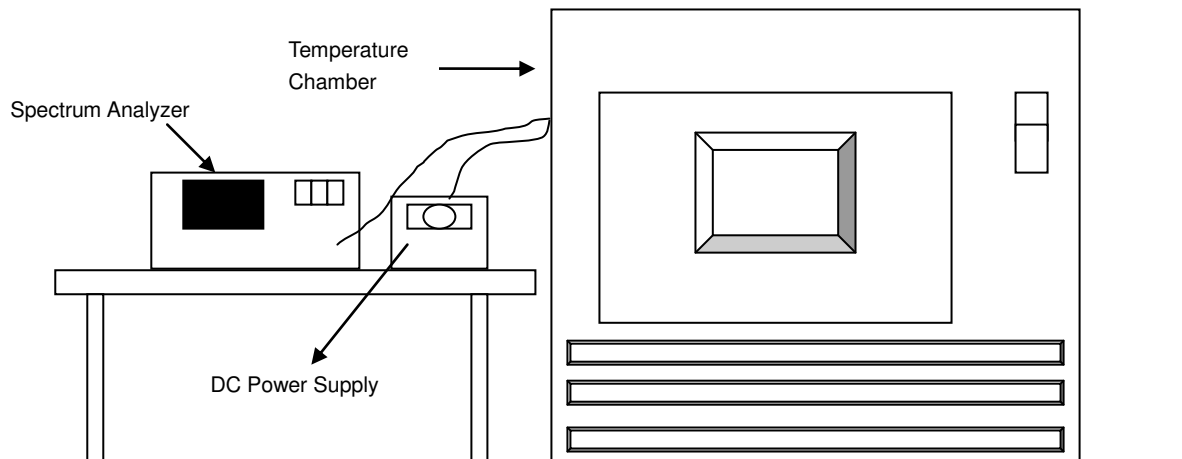

4.4.3 Test Instruments

Refer to section 4.1.3 to get information of above instrument.

4.4.4 Test Procedure

- To ensure emission at the band edge is maintained within the authorized band, those values shall be measured by radiation emissions at upper and lower frequency points, and finally compensated by frequency deviation as procedures below.
- The EUT was operated at the maximum output power, and connected to the spectrum analyzer, which is set to maximum hold function and peak detector. The peak value of the power envelope was measured and noted. The upper and lower frequency points were respectively measured relatively 10 dB lower than the measured peak value.
- The frequency deviation was calculated by adding the upper frequency point and the lower frequency point divided by two. Those detailed values of frequency deviation are provided in table below.

4.4.5 Deviation from Test Standard

No deviation.

4.4.6 EUT Operating Condition

Set the EUT transmit at un-modulation mode to test frequency stability.

4.4.7 Test Results

Frequency Stability Versus Temp.									
Operating Frequency: 5180 MHz									
Temp. (°C)	Power Supply (Vdc)	0 Minute		2 Minute		5 Minute		10 Minute	
		Measured Frequency (MHz)	Frequency Drift (ppm)	Measured Frequency (MHz)	Frequency Drift (ppm)	Measured Frequency (MHz)	Frequency Drift (ppm)	Measured Frequency (MHz)	Frequency Drift (ppm)
85	3.3	5180.015773	3.045	5180.016061	3.101	5180.015571	3.006	5180.015866	3.063
80	3.3	5180.015773	3.045	5180.016069	3.102	5180.016305	3.148	5180.015568	3.005
70	3.3	5180.015773	3.045	5180.016172	3.122	5180.016041	3.097	5180.015700	3.031
60	3.3	5180.015122	2.919	5180.015252	2.944	5180.015195	2.933	5180.015593	3.010
50	3.3	5180.015773	3.045	5180.015748	3.040	5180.015779	3.046	5180.016213	3.130
40	3.3	5180.015773	3.045	5180.015945	3.078	5180.016106	3.109	5180.015975	3.084
30	3.3	5180.016994	3.281	5180.017193	3.319	5180.017293	3.338	5180.016756	3.235
20	3.3	5180.017948	3.465	5180.018168	3.507	5180.018026	3.480	5180.018238	3.521
10	3.3	5180.019440	3.753	5180.019888	3.839	5180.019942	3.850	5180.019474	3.759
0	3.3	5180.017966	3.468	5180.017727	3.422	5180.017990	3.473	5180.017945	3.464
-10	3.3	5180.016426	3.171	5180.016719	3.228	5180.016448	3.175	5180.016546	3.194
-20	3.3	5180.015926	3.075	5180.016289	3.145	5180.016121	3.112	5180.016032	3.095
-30	3.3	5180.014835	2.864	5180.015021	2.900	5180.015270	2.948	5180.014652	2.829
-40	3.3	5180.014835	2.864	5180.015198	2.934	5180.015180	2.931	5180.015031	2.902

Frequency Stability Versus Temp.									
Operating Frequency: 5180 MHz									
Temp. (°C)	Power Supply (Vdc)	0 Minute		2 Minute		5 Minute		10 Minute	
		Measured Frequency (MHz)	Frequency Drift (ppm)	Measured Frequency (MHz)	Frequency Drift (ppm)	Measured Frequency (MHz)	Frequency Drift (ppm)	Measured Frequency (MHz)	Frequency Drift (ppm)
20	3.4	5180.017570	3.392	5180.016281	3.143	5180.016347	3.156	5180.015908	3.071
	3.3	5180.017948	3.465	5180.018168	3.507	5180.018026	3.480	5180.018238	3.521
	4.35	5180.019210	3.708	5180.015005	2.897	5180.015122	2.919	5180.015360	2.965

4.5 6 dB Bandwidth Measurement

4.5.1 Limits of 6 dB Bandwidth Measurement

The minimum of 6 dB Bandwidth Measurement is 0.5 MHz.

4.5.2 Test Setup

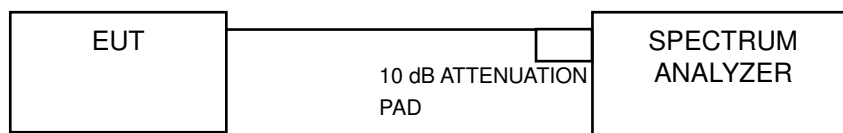

4.5.3 Test Instruments

Refer to section 4.1.3 to get information of above instrument.

4.5.4 Test Procedure

MEASUREMENT PROCEDURE REF

- Set resolution bandwidth (RBW) = 100 kHz
- Set the video bandwidth (VBW) $\geq 3 \times$ RBW, Detector = Peak.
- Trace mode = max hold.
- Sweep = auto couple.
- Measure the maximum width of the emission that is constrained by the frequencies associated with the two amplitude points (upper and lower) that are attenuated by 6 dB relative to the maximum level measured in the fundamental emission

4.5.5 Deviation from Test Standard

No deviation.

4.5.6 EUT Operating Condition

The software provided by client to enable the EUT under transmission condition continuously at lowest, middle and highest channel frequencies individually.

4.5.7 Test Results

Mode A
802.11a

Channel	Frequency (MHz)	6 dB Bandwidth (MHz)	Minimum Limit (MHz)	Pass / Fail
149	5745	16.37	0.5	Pass
157	5785	16.36	0.5	Pass
161	5805	16.37	0.5	Pass

802.11n (HT20)

Channel	Frequency (MHz)	6 dB Bandwidth (MHz)	Minimum Limit (MHz)	Pass / Fail
149	5745	17.14	0.5	Pass
157	5785	17.10	0.5	Pass
161	5805	17.07	0.5	Pass

802.11n (HT40)

Channel	Frequency (MHz)	6 dB Bandwidth (MHz)	Minimum Limit (MHz)	Pass / Fail
151	5755	36.11	0.5	Pass
159	5795	35.95	0.5	Pass

Mode B
802.11n (HT20)

Channel	Frequency (MHz)	6 dB Bandwidth (MHz)			Minimum Limit (MHz)	Pass / Fail
		Chain 0	Chain 1	Chain 2		
149	5745	16.57	16.96	17.57	0.5	Pass
157	5785	16.92	16.95	16.97	0.5	Pass
161	5805	16.31	16.94	16.36	0.5	Pass

802.11n (HT40)

Channel	Frequency (MHz)	6 dB Bandwidth (MHz)			Minimum Limit (MHz)	Pass / Fail
		Chain 0	Chain 1	Chain 2		
151	5755	35.29	35.80	35.28	0.5	Pass
159	5795	35.31	35.43	35.87	0.5	Pass

Spectrum Plot of Worst Value

802.11a

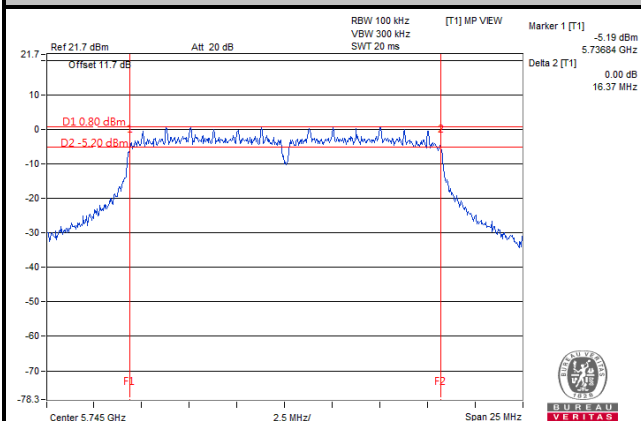

802.11n (HT20)

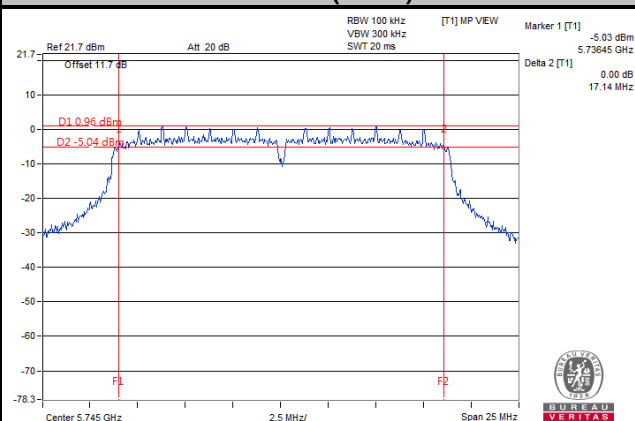

802.11n (HT40)

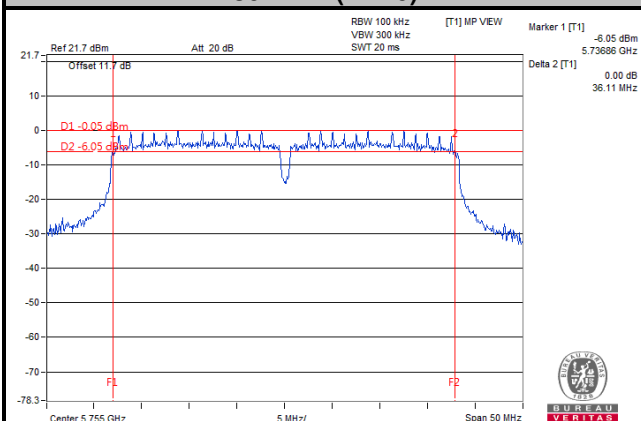

802.11ac (VHT80)

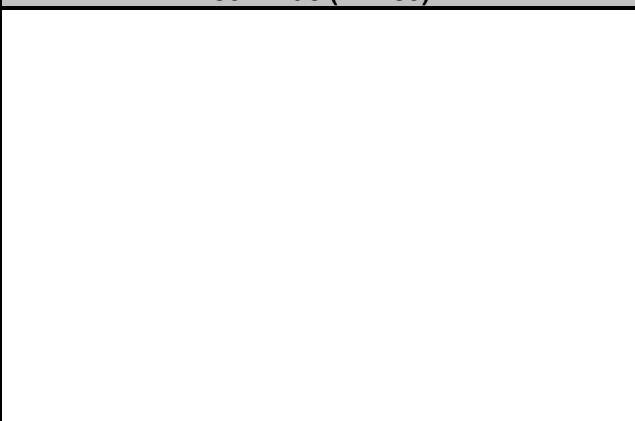

5 Pictures of Test Arrangements

Please refer to the attached file (Test Setup Photo).

Annex A- Radiated Out of Band Emisison (OOBE) Measurement (For U-NII-3 band)

Mode A

802.11a

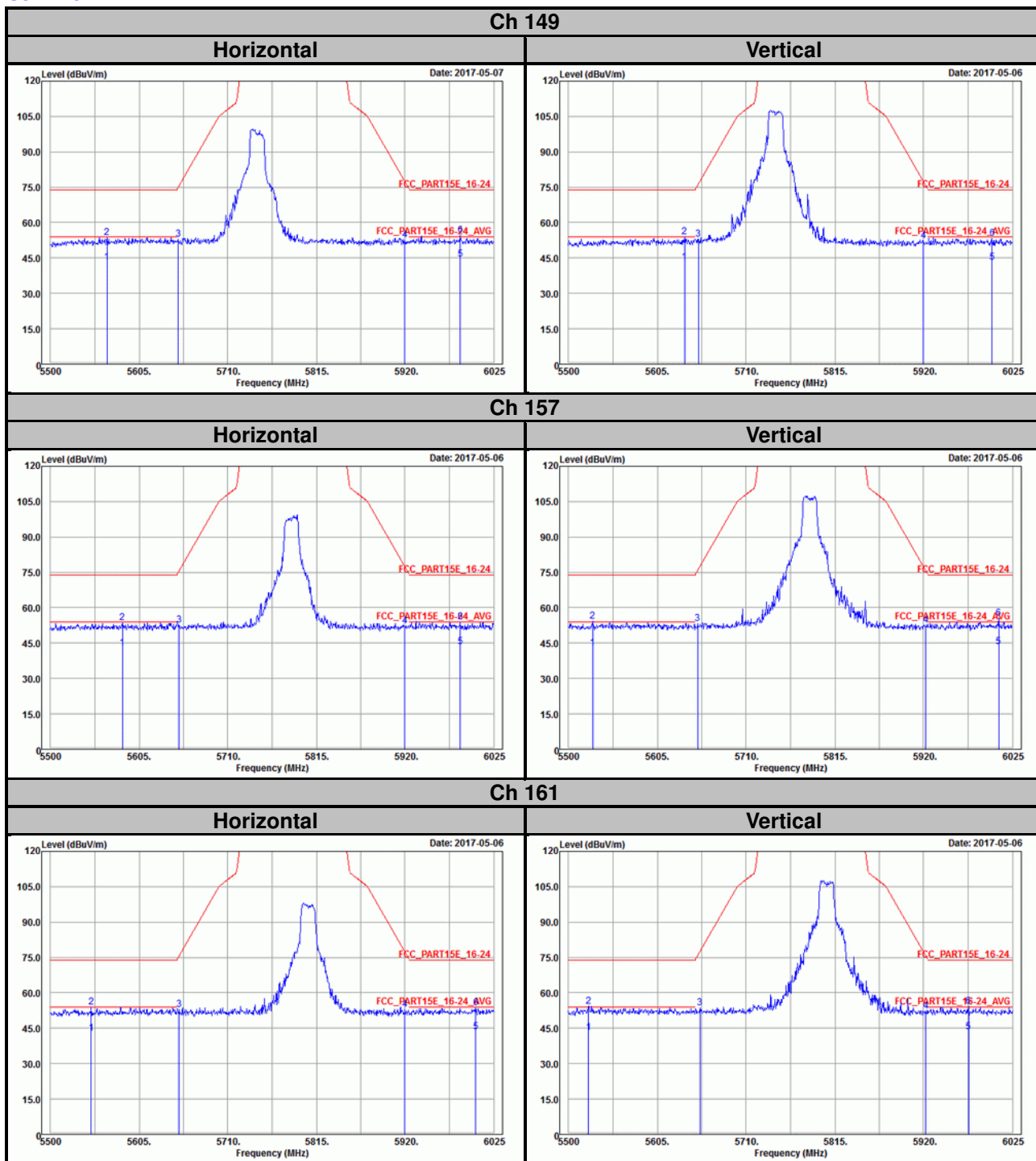

Mode B
802.11n (HT20)

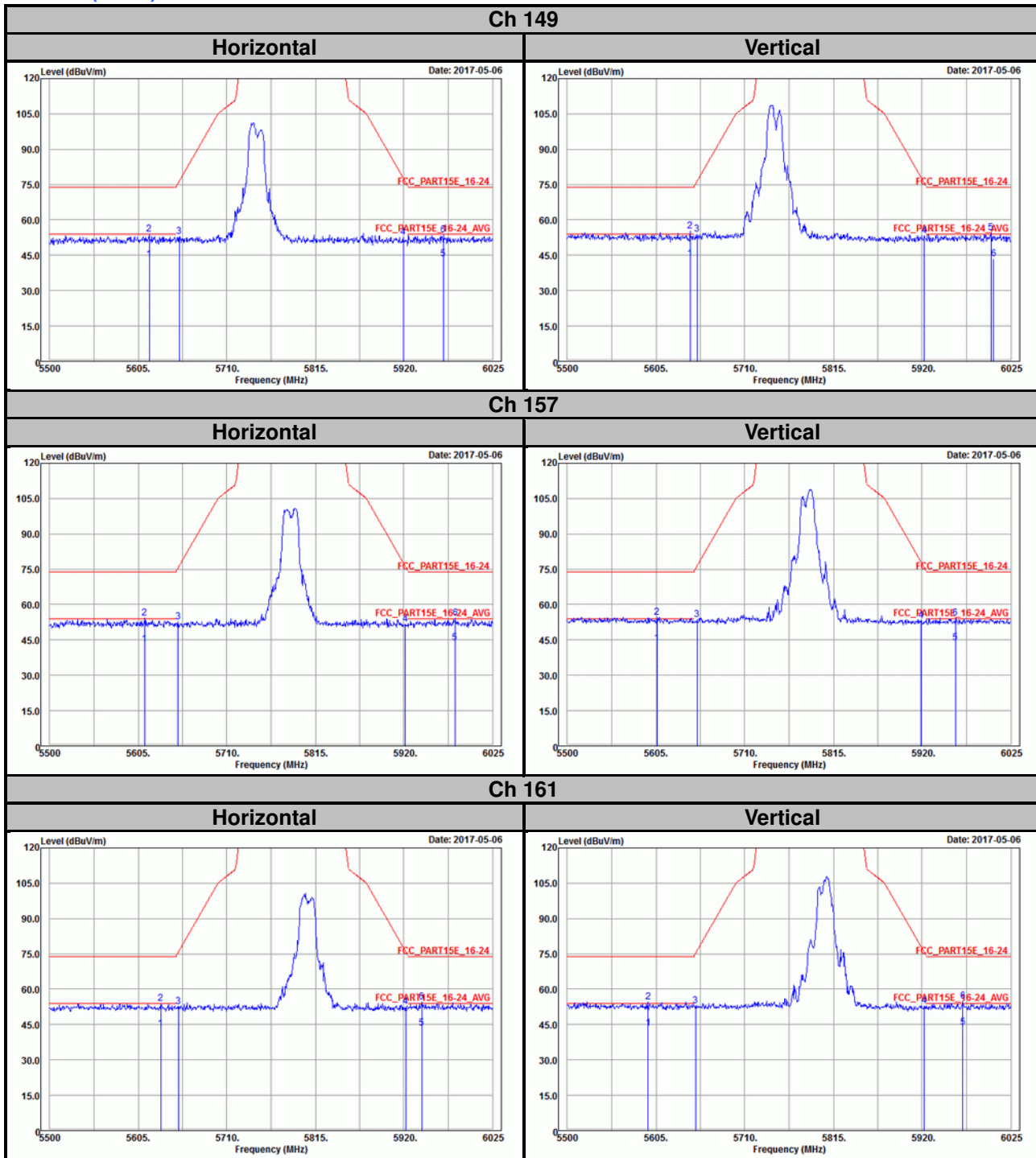

802.11n (HT40)

Ch 151

Horizontal

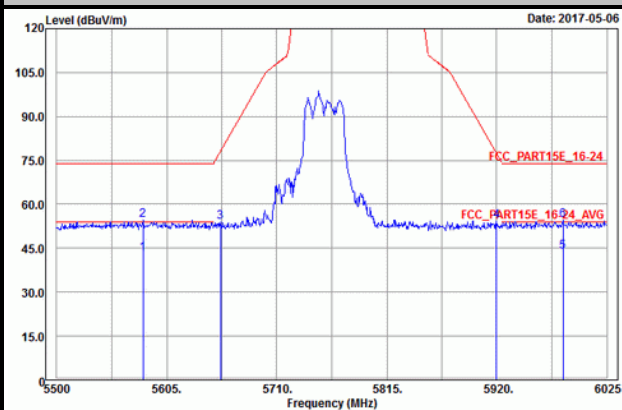

Vertical

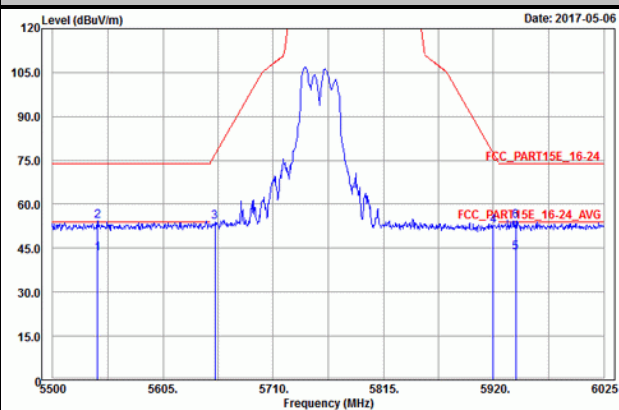

Ch 159

Horizontal

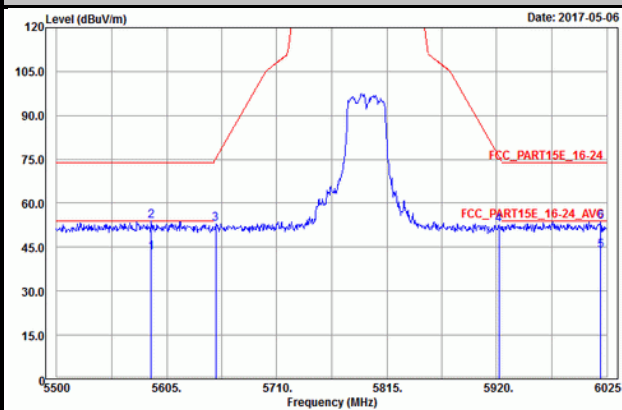

Vertical

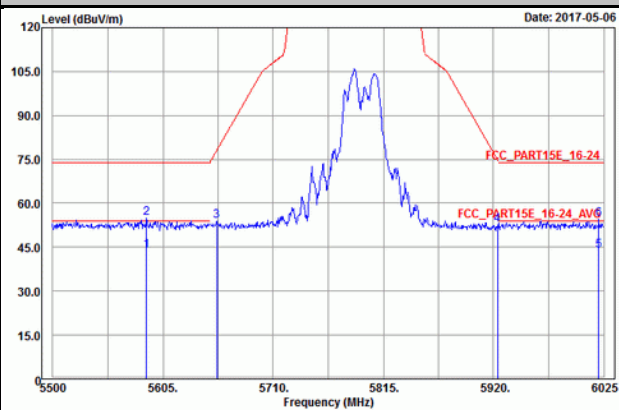

Appendix – Information on the Testing Laboratories

We, Bureau Veritas Consumer Products Services (H.K.) Ltd., Taoyuan Branch, were founded in 1988 to provide our best service in EMC, Radio, Telecom and Safety consultation. Our laboratories are accredited and approved according to ISO/IEC 17025.

If you have any comments, please feel free to contact us at the following:

Linko EMC/RF Lab

Tel: 886-2-26052180

Fax: 886-2-26051924

Hsin Chu EMC/RF/Telecom Lab

Tel: 886-3-6668565

Fax: 886-3-6668323

Hwa Ya EMC/RF/Safety

Tel: 886-3-3183232

Fax: 886-3-3270892

Email: service.adt@tw.bureauveritas.com

Web Site: www.bureauveritas-adt.com

The address and road map of all our labs can be found in our web site also.

--- END ---